

The mechanics of undulatory locomotion: the mixed kinematic and dynamic case

James P. Ostrowski* Joel W. Burdick† Andrew D. Lewis‡ Richard M. Murray§

1995/03/01

Last updated: 1998/03/02

Abstract

This paper studies the mechanics of undulatory locomotion. This type of locomotion is generated by a coupling of internal shape changes to external nonholonomic constraints. Employing methods from geometric mechanics, we use the dynamic symmetries and kinematic constraints to develop a specialised form of the dynamic equations which govern undulatory systems. These equations are written in terms of physically meaningful and intuitively appealing variables that show the role of internal shape changes in driving locomotion.

Keywords. mechanics, symmetries, constraints.

AMS Subject Classifications (2020). 70H25, 70H30, 70H33, 70H03.

1. Introduction

A significant body of research has been developed in the area of robotic locomotion. However, prior studies have been focused either on a particular set of assumptions or a particular robot morphology. For example, numerous investigators have studied and demonstrated quasi-static, multi-legged locomotion (see [Song and Waldron 1989]). Beginning with [Raibert 1986], hopping robots have received considerable attention (see [Berke-meier and Fearing 1992, Koditschek and Bühler 1991]). Bipedal walking and running has also been an active area of study (see [Kajita and Tani 1991, McGeer 1990]). Other researchers have considered and implemented various forms of “snake-like” locomotion schemes (see [Chirikjian and Burdick 1991, Hirose and Umetani 1976]) and investigated the

*Assistant Professor, DEPARTMENT OF MECHANICAL ENGINEERING AND APPLIED MECHANICS, UNIVERSITY OF PENNSYLVANIA, 297 TOWNE BUILDING, 220 S. 33RD STREET, PHILADELPHIA, PA, U.S.A.

Email: jpo@grip.cis.upenn.edu, URL: <http://www.seas.upenn.edu/meam/ostrowski.html>

Work performed while a Graduate Research Assistant at the California Institute of Technology.

†Professor, DEPARTMENT OF MECHANICAL ENGINEERING, MAIL CODE 104–44 CALIFORNIA INSTITUTE OF TECHNOLOGY, PASADENA, CA 91125, U.S.A.

Email: jwb@robotics.caltech.edu, URL: <http://robotics.caltech.edu/~jwb/jwb.html>

‡Professor, DEPARTMENT OF MATHEMATICS AND STATISTICS, QUEEN’S UNIVERSITY, KINGSTON, ON K7L 3N6, CANADA

Email: andrew.lewis@queensu.ca, URL: <http://www.mast.queensu.ca/~andrew/>

Work performed while a Graduate Research Assistant at the California Institute of Technology.

§Professor, CONTROL AND DYNAMICAL SYSTEMS, MAIL CODE 104–44 CALIFORNIA INSTITUTE OF TECHNOLOGY, PASADENA, CA 91125, U.S.A.

Email: murray@indra.caltech.edu, URL: <http://avalon.caltech.edu/~murray/>

geometry of amoeba swimming through a viscous fluid (see [Shapere and Wilczek 1989]). However, to date there exists no unifying methodology for analysing or controlling robot locomotion. Ultimately, we seek a *mechanics theory* and a *control theory* for robotic locomotion which is uniformly applicable to a broad class of locomotory problems. This paper introduces a unifying mechanics principle for ***undulatory locomotion***.

Definition: *Undulatory locomotion is the process of generating net displacements of a robotic mechanism via a coupling of internal deformations to an interaction between the robot and its environment.*

Common biological examples of undulatory locomotion include worms, snakes, amoeba, and fish. In this paper, we limit these interactions to those modelled by nonholonomic kinematic constraints. This restriction allows us to model a rich class of systems and results in enough structure to make the problem tractable. We believe that the framework presented here will provide the basis for an undulatory locomotion control theory, and will ultimately be extended to a large class of locomotory systems.

This work has several goals and contributions. First we show that locomotion problems can naturally be cast in the framework of ***principal fibre bundles***. Second, using this structure, we derive a specialised form of the dynamical equations for mechanical systems with Lagrangian symmetries and nonholonomic constraints (which are characteristic of many undulatory locomotors). Third, we show how these results lead to a simple and appealing insight into undulatory locomotion. Finally, we show that the framework presented here is in fact a superset of prior work on the mechanics of wheeled nonholonomic vehicles and free-floating satellites.

The results in this paper draw significantly from recent results in Lagrangian mechanics due to Koiller [1992] and Bloch, Krishnaprasad, Marsden, and Murray [1996]. We also note that the role of connections in problems of locomotion has been explored in [Kelly and Murray 1994], where results were developed regarding mechanics and control in the case of purely kinematic constraints.

2. Mechanics

It is always possible to divide a locomoting robot's configuration variables into two classes. The first class of variables describes the *position* of the robot. We define this to be the displacement of a coordinate frame attached to the moving robot mechanism with respect to a fixed reference frame. Since robots move in Euclidean space, the set of body frame displacements is $SE(n)$, $n \leq 3$, or one of its subgroups — i.e., a Lie group. The second class of variables defines the internal configuration, or ***shape***, of the mechanism. We require only that the set of all possible shapes be described by a manifold, M . Hence, the Lie group, G , together with the shape space, M , form the total configuration space of the system, which we denote by $Q = G \times M$. A given configuration is denoted by $q \in Q$.

Since we are working with mechanical systems, we will assume the existence of a Lagrangian function, $L(q, \dot{q})$, on TQ , the tangent bundle of Q . In the absence of constraints, the robot's dynamical equations can be derived from Lagrange's equations:

$$\frac{d}{dt} \left(\frac{\partial L}{\partial \dot{q}^i} \right) - \frac{\partial L}{\partial q^i} - \tau_i = 0, \quad (2.1)$$

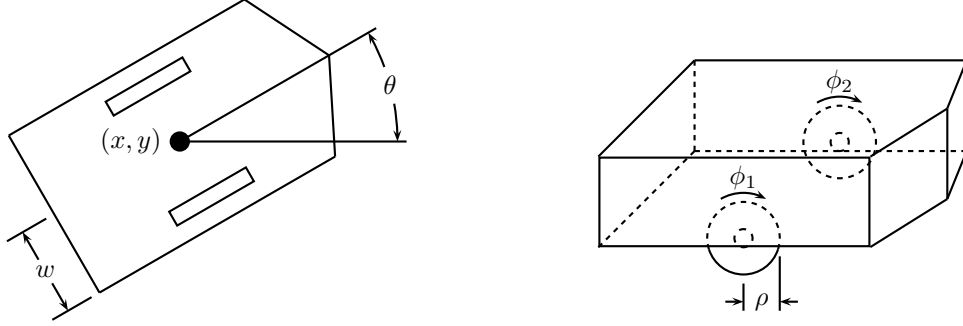

Figure 1. Two wheeled planar mobile robot.

where τ is a forcing function. In general, though, undulatory locomotion *requires* some type of interaction with the environment, which we will model as a constraint. These constraints can take many forms, including viscous friction, no-slip wheel conditions, and interaction of a surface with a viscous fluid or air. Let us restrict our attention to constraints which are linear in the velocities. Given k such constraints, we can write them as a vector-valued set of k equations:

$$\omega_j^i(q)\dot{q}^j = 0, \quad \text{for } i = 1 \dots k. \quad (2.2)$$

This class of constraints includes most commonly investigated nonholonomic constraints.

The constraints can be incorporated into the dynamics through the use of Lagrange multipliers. That is, Eq. 2.1 is modified by adding a force of constraint with an unknown multiplier, λ .

$$\frac{d}{dt}\left(\frac{\partial L}{\partial \dot{q}^i}\right) - \frac{\partial L}{\partial q^i} + \lambda_j \omega_j^i - \tau_i = 0. \quad (2.3)$$

2.1 Example: Consider the two wheeled planar mobile robot shown in Figure 1. The robot's position, $(x, y, \theta) \in SE(2)$, is measured via a frame located at the centre of the wheel base. The position of the wheels is measured relative to vertical and is denoted (ϕ_1, ϕ_2) . Each wheel is assumed to rotate independently and without slipping. The configuration space is then $Q = G \times M = SE(2) \times (\mathbf{S}^1 \times \mathbf{S}^1)$. The Lagrangian for this problem is

$$L = \frac{1}{2}m(\dot{x}^2 + \dot{y}^2) + \frac{1}{2}J\dot{\theta}^2 + \frac{1}{2}J_w(\dot{\phi}_1^2 + \dot{\phi}_2^2),$$

where m is the mass of the robot, J is its inertia, and J_w is the inertia of each of the wheels. The constraints defining the no-slip condition can be written as in Eq. 2.2:

$$\begin{aligned} \dot{x} \cos \theta + \dot{y} \sin \theta - \frac{\rho}{2}(\dot{\phi}_1 + \dot{\phi}_2) &= 0 \\ -\dot{x} \sin \theta + \dot{y} \cos \theta &= 0 \\ \dot{\theta} - \frac{\rho}{2w}(\dot{\phi}_1 - \dot{\phi}_2) &= 0. \end{aligned} \quad (2.4)$$

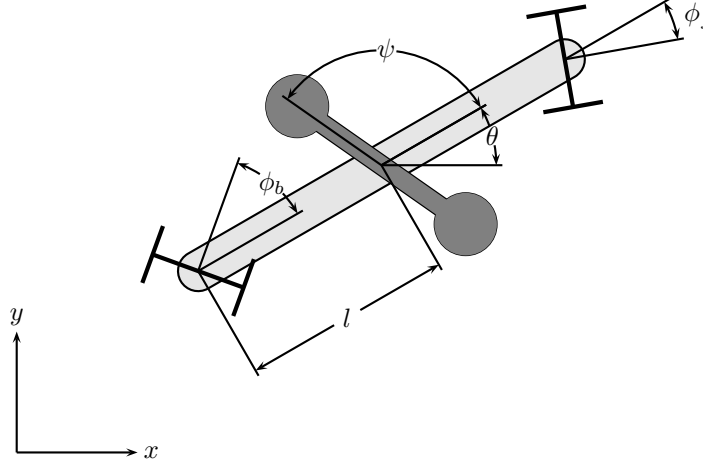

Figure 2. The simplified model of the *Snakeboard*.

The equations of motion can then be derived using Eq. 2.3. In this case, however, the kinematic constraints provide an immediate way of determining the robot's motion as a function of internal shape changes since there are three constraints on the three dimensional group of body displacements. If we make the standard assumption that the base variables are controllable, then given the time evolution of ϕ_1 and ϕ_2 , we can completely solve for the motion of the robot using Eq. 2.4, which we rewrite in a slightly more revealing manner:

$$\begin{pmatrix} \cos \theta & \sin \theta & 0 \\ -\sin \theta & \cos \theta & 0 \\ 0 & 0 & 1 \end{pmatrix} \begin{pmatrix} \dot{x} \\ \dot{y} \\ \dot{\theta} \end{pmatrix} = \begin{pmatrix} \frac{\rho}{2}(\dot{\phi}_1 + \dot{\phi}_2) \\ 0 \\ \frac{\rho}{2w}(\dot{\phi}_1 - \dot{\phi}_2) \end{pmatrix}. \quad (2.5)$$

•

That is, the motion in the group variables, $(\dot{x}, \dot{y}, \dot{\theta})$, is strictly a function of the internal shape velocities $(\dot{\phi}_1, \dot{\phi}_2)$.

2.2 Example: Next we turn to an example which will be used throughout the paper for the purposes of illustration. The simplified model of the *Snakeboard* (c.f., [Lewis, Ostrowski, Murray, and Burdick 1994]) is shown in Figure 2 and consists of a rigid body connecting two sets of wheels whose rotations can be independently specified. Attached is a momentum wheel which rotates about the centre of mass, thereby exerting a torque on the lower portion of the board. The snakeboard's position variables are $(x, y, \theta) \in G = SE(2)$, and are determined by a frame affixed to its centre of mass. The internal shape variables are (ψ, ϕ_b, ϕ_f) , and so the base space is $\mathbf{S}^1 \times \mathbf{S}^1 \times \mathbf{S}^1 = M$. The configuration space is $Q = G \times M = SE(2) \times \mathbf{S}^1 \times \mathbf{S}^1 \times \mathbf{S}^1$. The Lagrangian is

$$L = \frac{1}{2}m(\dot{x}^2 + \dot{y}^2) + \frac{1}{2}J\dot{\theta}^2 + \frac{1}{2}J_r(\dot{\psi} + \dot{\theta})^2 + \frac{1}{2}J_w((\dot{\phi}_b + \dot{\theta})^2 + (\dot{\phi}_f + \dot{\theta})^2). \quad (2.6)$$

Control torques at the rotor and wheels are assumed, so

$$\tau = (0, 0, 0, \tau_\psi, \tau_b, \tau_f).$$

The assumption that the wheels do not slip in the direction of the wheel axes determines two constraints that can be written as linear functions of the velocities:

$$\begin{aligned} -\sin(\phi_f + \theta)\dot{x} + \cos(\phi_f + \theta)\dot{y} + l\cos(\phi_f)\dot{\theta} &= 0 \\ -\sin(\phi_b + \theta)\dot{x} + \cos(\phi_b + \theta)\dot{y} - l\cos(\phi_b)\dot{\theta} &= 0. \end{aligned} \tag{2.7}$$

•

Notice that for the snakeboard we no longer have enough kinematic constraints to uniquely define the motion of the robot. For this reason, the simple technique of using the constraints to solve for the robot's motion as a function of shape changes that was employed in the first example is no longer viable. The snakeboard's dynamics must come into play. Thus, we are relegated to using Eqs. 2.2 and 2.3 to define the robot's dynamics and explicitly solving for k unknown Lagrange multipliers. There are a number of drawbacks to this approach. First, the system is equivalent to $2n + k$ first order differential equations. Second, physical intuition is often lost when eliminating the Lagrange multipliers. That is, we do not have a relationship, such as Eq. 2.5, in which the effect of internal shape changes on robot motion is readily apparent. Third, it is difficult to incorporate into Eq. 2.3 any special features which might simplify the ensuing analysis. With these issues in mind, we now embark upon an alternate approach in order to make use of the additional structure given to us by the inherent symmetries found in problems of locomotion.

3. Mechanics with symmetries

3.1. Mathematical background. We begin by introducing some general mathematical concepts, which will be illustrated by the snakeboard example. First, we show that locomotion systems can be modelled on a *principal fibre bundle* and review some ideas that are associated with them.

Recall the division of the configuration space, $Q = G \times M$. Such a configuration space is termed a *trivial fibre bundle*. G is called the *fibre*, and Q is said to be fibred over the *base* space, M . Q is "trivial" because the product structure is global. In our context, the words fibre and base are interchangeable with robot position and internal shape, respectively. There are two natural projections which we will use. Given a point $(g, r) \in G \times M = Q$, define these projections as $\pi_1 : Q \rightarrow G : (g, r) \mapsto g$ and $\pi_2 : Q \rightarrow M : (g, r) \mapsto r$.

The use of a Lie group will be important for describing the robot's motion through its environment. Formally, the displacement of the robot's body fixed frame is considered as a *left translation*. That is, if the robot's initial position is denoted by g , and it is displaced by an amount h , then its final position is hg . This displacement can be thought of as a map $L_h : G \rightarrow G$ given by $L_h(g) = hg$ for $g \in G$. The left translation induces a *left action* of G on Q .

3.1 Definition: A *left action* of a Lie group G on a manifold Q is a smooth map $\Phi : G \times Q \rightarrow Q$ such that: (1) $\Phi(e, q) = q$ for all $q \in Q$, and e the identity element of G ; and (2) $\Phi(h, \Phi(g, q)) = \Phi(hg, q)$ for every $g, h \in G$ and $q \in Q$. •

It will be useful to consider the left action as a map from Q into Q , with the element $h \in G$ held fixed. Notationally, $\Phi_h : Q \rightarrow Q$ is given by $(g, r) \mapsto (\Phi(h, g), r) = (hg, r)$. The *lifted action*, which describes the effect of Φ_h on velocity vectors in TQ , is the tangent map of Φ_h . This is the linear map, $D_q\Phi_h : T_qQ \rightarrow T_{hq}Q$ (often denoted $T_q\Phi_h$).

3.2 Definition: Let M be a manifold and G a Lie group. A *trivial principal fibre bundle* with *base* M and *structure group* G consists of the manifold $Q = G \times M$ together with the free left action of G on Q given by left translation on the group variable: $\Phi_h(g, r) = (hg, r)$ for $r \in M$ and $h, g \in G$. •

That is, our bundle configuration space has additional structure arising from the Lie group component. This additional structure is important for the ensuing developments.

Example 2.2: (cont'd) The configuration space for the snakeboard is $Q = G \times M = SE(2) \times (\mathbb{S}^1 \times \mathbb{S}^1 \times \mathbb{S}^1)$, and a configuration is denoted $q = (x, y, \theta, \psi, \phi_b, \phi_f)$. The action is the left action of $SE(2)$ on itself. Given $h = (a_1, a_2, \alpha) \in SE(2)$,

$$\Phi_h(q) = (x \cos \alpha - y \sin \alpha + a_1, x \sin \alpha + y \cos \alpha + a_2, \theta + \alpha, \psi, \phi_b, \phi_f).$$

From this the lifted action is easily computed as

$$D_q \Phi_h(v_q) = (v_x \cos \alpha - v_y \sin \alpha, v_x \sin \alpha + v_y \cos \alpha, v_\theta, v_\psi, v_b, v_f),$$

where $v_q = (v_x, v_y, v_\theta, v_\psi, v_b, v_f) \in T_q Q$ is a point in the tangent space of Q at q . •

Associated with a Lie group, G , is its Lie algebra, denoted \mathfrak{g} . The Lie algebra can be identified with $T_e G$ and generates G via the exponential mapping, $\exp : \mathfrak{g} \rightarrow G$ (see [Abraham and Marsden 1978]). The exponential mapping also associates with each $\xi \in \mathfrak{g}$ a vector field on G , and by extension on $Q = G \times M$, called the *infinitesimal generator*, ξ_Q , given by

$$\xi_Q(q) = \frac{d}{ds}(\Phi(\exp(s\xi), q))|_{s=0}. \quad (3.1)$$

Each infinitesimal generator is tangent to the fibre, and the set of all such vectors at $q \in Q$ forms a subspace of $T_q Q$ called the *vertical* subspace,

$$V_q Q = \{\xi_Q(q) \in T_q Q \mid \xi \in \mathfrak{g}\}.$$

Eq. 3.1 takes elements of the Lie algebra and maps them to infinitesimal generators. It is an isomorphism between \mathfrak{g} and $V_q Q$. This implies that any vector $v_q \in V_q Q$ can be written as the infinitesimal generator at q of some Lie algebra element, i.e., $v_q = \xi_Q(q)$ for some $\xi \in \mathfrak{g}$.

Example 2.2: (cont'd) The Lie algebra for $SE(2)$ is denoted $se(2)$, and the relationship between an element, $\xi = (a_1, a_2, \alpha) \in se(2)$, and the corresponding infinitesimal generator on TQ is given by

$$\xi_Q(x, y, \theta, \psi, \phi_b, \phi_f) = (a_1 - y\alpha, a_2 + x\alpha, \alpha, 0, 0, 0).$$

The vertical subspace is given trivially by $TG \times \{0\}$:

$$\begin{aligned} V_q Q &= \{(v_q, w_q) \in T_{\pi_1(q)} G \times T_{\pi_2(q)} M = T_q Q \mid w_q = 0\} \\ &= \text{sp} \left\{ \frac{\partial}{\partial x}, \frac{\partial}{\partial y}, \frac{\partial}{\partial \theta} \right\}. \end{aligned} \quad (3.2)$$

•

3.2. Noether's theorem. Conservation laws (e.g., conserved linear and angular momentum) naturally arise when a Lagrangian remains invariant under the action of a Lie group, as stated in Noether's theorem (see [Abraham and Marsden 1978, Bloch, Krishnaprasad, Marsden, and Murray 1996]):

3.3 Theorem: (Noether) *Let L be a Lagrangian which is invariant under the action of a Lie group, G , (i.e., $L(\Phi_h(q), D_q\Phi_h v_q) = L(q, v_q) \forall h \in G, v_q \in T_q Q$). Then, for all curves, $c(t) : [a, b] \rightarrow Q$ satisfying Lagrange's equations (Eq. 2.1), we have that*

$$\frac{d}{dt} \left\langle \frac{\partial L}{\partial \dot{q}}(\dot{c}(t)); \xi_Q(c(t)) \right\rangle = 0$$

for all $\xi \in \mathfrak{g}$. Equivalently, $\dot{p} = 0$, where $p = \langle \frac{\partial L}{\partial \dot{q}}; \xi_Q \rangle$ is the **generalised momentum**.

For the case in which G is $SE(2)$ or $SE(3)$, Noether's theorem is equivalent to conservation of linear and angular momentum. However, undulatory locomotion relies on some type of interaction with the environment. Unfortunately, conservation laws are not necessarily preserved in the presence of the constraints which are inherent to undulatory locomotion. The next section describes an extension to the classical theory that combines the effects of symmetries and constraints.

3.3. Symmetries with constraints. Given the constraints as in Eq. 2.2, we can write the **constraint distribution** (i.e., the set of all velocities that satisfy the constraints) as

$$\mathcal{D}_q = \{v_q \in T_q Q \mid \omega_j^i v_q^j = 0, \forall i = 1, \dots, k\}. \quad (3.3)$$

The constraints are said to act **vertically** if the **constrained fibre distribution**,

$$\mathcal{S} = \mathcal{D} \cap VQ, \quad (3.4)$$

is nonempty. Assuming this to be true, we have the following proposition, first developed in [Bloch, Krishnaprasad, Marsden, and Murray 1996]. For proofs of this proposition and those to follow, the reader is referred to [Bloch, Krishnaprasad, Marsden, and Murray 1996].

3.4 Proposition: *Let L and \mathcal{D} define a constrained system on $Q = G \times M$ whose Lagrangian is G -invariant. If c is a curve which satisfies the Lagrange-d'Alembert equations (Eq. 2.3) for a system with nonholonomic constraints (Eq. 2.2), then the following **generalised momentum equation** holds for all vector fields, $\xi_Q^c \in \mathcal{S}$:*

$$\frac{d}{dt} p^c = \frac{\partial L}{\partial \dot{q}^i} \left(\frac{d}{dt} [\xi^c(c(t))] \right)_Q^i + \tau_i \left(\xi^c(c(t)) \right)_Q^i \quad (3.5)$$

where

$$p^c = \frac{\partial L}{\partial \dot{q}^i} (\xi^c(c(t)))_Q^i \quad (3.6)$$

is the **constrained momentum**.

That is, in the presence of constraints, momentum-like quantities exist, but they may not be conserved. Eq. 3.5 determines how the momentum-like quantity, p^c , evolves. *The non-conservation of momentum-like quantities is the key to dynamic undulatory locomotion.* It describes why the snakeboard can start from rest and build up momentum, even though no external forces act on the system (see [Lewis, Ostrowski, Murray, and Burdick 1994]).

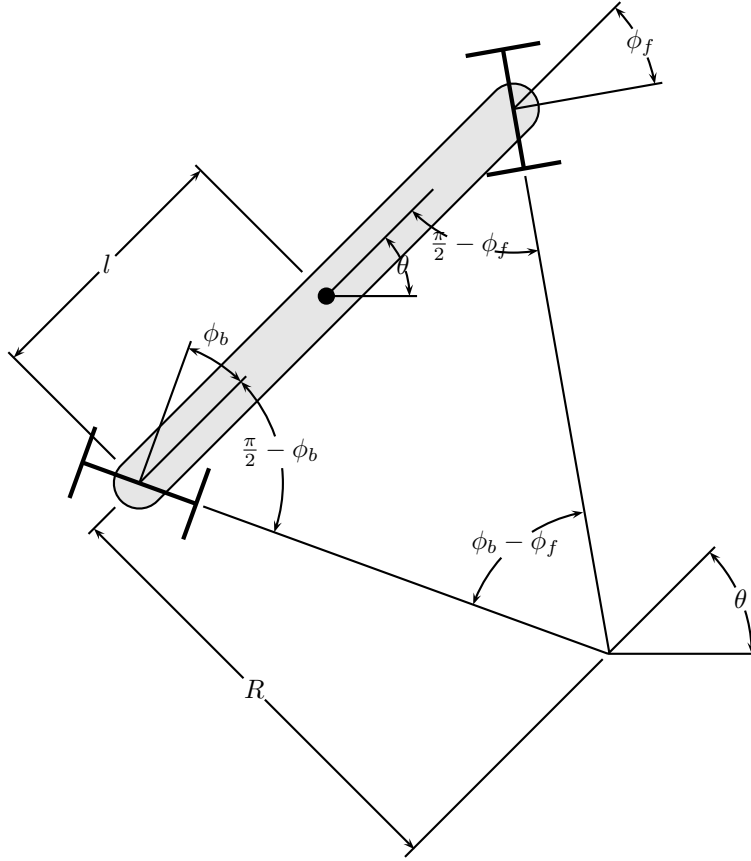

Figure 3. Instantaneous centre of rotation

Example 2.2: (cont'd) An easy calculation shows that the snakeboard Lagrangian, Eq. 2.6, is invariant with respect to the $SE(2)$ group action. The wheel constraints of Eq. 2.7 can be expressed as a constraint distribution:

$$\mathcal{D}_q = \text{sp}\left\{a \frac{\partial}{\partial x} + b \frac{\partial}{\partial y} + c \frac{\partial}{\partial \theta}, \frac{\partial}{\partial \psi}, \frac{\partial}{\partial \phi_b}, \frac{\partial}{\partial \phi_f}\right\},$$

where

$$\begin{aligned} a &= -l[\cos \phi_b \cos(\phi_f + \theta) + \cos \phi_f \cos(\phi_b + \theta)] \\ b &= -l[\cos \phi_b \sin(\phi_f + \theta) + \cos \phi_f \sin(\phi_b + \theta)] \\ c &= \sin(\phi_b - \phi_f). \end{aligned}$$

The vertical distribution was defined in Eq. 3.2, and so the constrained fibre distribution is:

$$\mathcal{S}_q = \mathcal{D}_q \cap V_q Q = \text{span}\left\{a \frac{\partial}{\partial x} + b \frac{\partial}{\partial y} + c \frac{\partial}{\partial \theta}\right\}.$$

Note, the constrained fibre distribution physically corresponds to instantaneous rotations of the snakeboard about a point where the two snakeboard wheel axes intersect (Figure 3).

This basis for \mathcal{S} satisfies the necessary conditions given in Proposition 3.4. For the snakeboard, the **constrained momentum** of Eq. 3.6 is computed as

$$\begin{aligned} p^c &= \left\langle \frac{\partial L}{\partial \dot{q}}; (\xi^c)_Q(q) \right\rangle \\ &= \langle (m\dot{x}, m\dot{y}, \hat{J}\dot{\theta}, J_r\dot{\psi}, J_w\dot{\phi}_b, J_w\dot{\phi}_f); (a, b, c, 0, 0, 0) \rangle \\ &= m\dot{x} + m\dot{y} + \hat{J}c\dot{\theta} + J_r\dot{\psi} + J_w c(\dot{\phi}_b + \dot{\phi}_f) \\ &= (mR^2 + \hat{J}c)\dot{\theta} + J_r\dot{\psi} + J_w c(\dot{\phi}_b + \dot{\phi}_f), \end{aligned}$$

where $\xi_Q^c \in \mathcal{S}$, $\hat{J} = J + J_r + 2J_w$ is the sum of the moments of inertia, and R is the radius from the instantaneous centre of rotation to the snakeboard's centre of mass (Fig. 3). Thus, p^c corresponds to the snakeboard's angular momentum about the instantaneous centre of rotation. If the front and back wheels were fixed, this momentum would be conserved, as the wheels would provide a holonomic constraint forcing the snakeboard to rotate about the fixed centre. For the snakeboard, the constrained momentum is one-dimensional. In general we would derive momenta corresponding to each unconstrained degree of freedom along the group orbit, i.e., the number of momenta would equal $\dim \mathcal{S}$. The generalised momentum equation, Eq. 3.5, for the snakeboard is:

$$\dot{p}^c = m\dot{x} + m\dot{y} + \hat{J}c\dot{\theta} + J_r\dot{\psi} + J_w c(\dot{\phi}_b + \dot{\phi}_f) \quad \bullet$$

3.4. Constructing the connection. We now introduce a key concept in the theory of principal fibre bundles which also has an important role in locomotion analysis.

3.5 Definition: ([Kobayashi and Nomizu 1963]) A **connection** is an assignment of a horizontal subspace, $H_qQ \subset T_qQ$, for each point $q \in Q$ such that

- (i) $T_qQ = V_qQ \oplus H_qQ$,
- (ii) $D_q\Phi_h H_qQ = H_{h \cdot q}Q$, for every $q \in Q$ and $h \in G$, and
- (iii) H_qQ depends smoothly on q . •

Condition (1) implies that T_qQ can everywhere be divided into a vertical subspace, V_qQ , and a **horizontal** subspace, H_qQ . Connections are useful because of the following fact. The horizontal subspace defined by the connection is everywhere isomorphic to the tangent space of the base: $H_qQ \simeq T_{\pi_2(q)}M$. The **horizontal lift** is the isomorphism which maps vectors in $T_{\pi_2(q)}M$ to the corresponding lifted vectors in $H_qQ \subset T_qQ$ under this identification. The horizontal lift, then, is the key to understanding the relationship between motion in the base space (via tangent vectors on $T_{\pi_2(q)}M$) and motion in the total space, Q , where locomotion is effected.

The connection is a general geometric structure that will enable us to describe how internal shape changes create net robot motion. This is the generalisation and formalisation of the intuitive procedure that lead to Eq. 2.5. As shown in the snakeboard, the kinematic constraints, Eq. 2.2, are generally not sufficient to define the robot's motion. It is necessary to supplement the kinematic constraints with symmetry constraints, in the form of the constrained momenta, in order to define a connection. In order to do so, we must make

two assumptions regarding \mathcal{S} . The first assumption, that the constraints be G -invariant, is a natural one when dealing with locomotion. Like the Lagrangian, locomotion constraints should not depend upon the robot's absolute position and orientation, and so are expected to be invariant with respect to the group. The second assumption is more technical in nature. Let $\dim G = s$. Then it is assumed that $\dim \mathcal{S} = \dim \mathcal{D} - \dim M = s - k$. Intuitively, this assumption implies that there are no constraints acting directly on the internal shape changes.

Given these assumptions, the constrained momenta described in Proposition 3.4 give the additional constraints necessary to construct a connection. Recall that Eq. 2.2 gives k constraints, $\omega^i(q)\dot{q} = 0$, $i = 1, \dots, k$, on an s -dimensional group. Given our dimensional assumption on \mathcal{S} , we can choose a basis for \mathcal{S} and hence develop $s - k$ additional **affine** constraint equations, $\omega^{k+1}, \dots, \omega^s$, from the constrained momenta,

$$\omega_j^{k+i}\dot{q}^j = (p^c)^i = \frac{\partial L}{\partial \dot{q}^j}((\xi^c)_Q^{k+i})_j(q), \quad (3.7)$$

where the $(\xi^c)_Q^{k+i}$ form a basis for \mathcal{S} , and hence each $(\xi^c)^{k+i}$ lies in \mathfrak{g} (but may vary pointwise over Q). In order to establish an invariant horizontal distribution (i.e., satisfy condition (2) of Defn. 3.5), we must show that Eq. 3.7 is G -invariant.

3.6 Proposition: *Given a system with L and \mathcal{D} G -invariant, and for which there exists a G -invariant basis for \mathcal{S} , X^1, \dots, X^{s-k} , the constrained momentum given by $(p^c)^i(v_q) = \langle \frac{\partial L}{\partial \dot{q}}(v_q); X^i(v_q) \rangle$ is itself G -invariant, i.e., $(p^c)^i(T_q\Phi_h v_q) = (p^c)^i(v_q)$, for $i = 1, \dots, s - k$.*

The constrained momenta of Eq. 3.7 may then be appended to the kinematic constraints of Eq. 2.2 in order to define the **fibre equations**:

$$\omega \dot{q} = \tilde{\gamma}, \quad (3.8)$$

where $\tilde{\gamma} = (0, \dots, 0, (p^c)^1, \dots, (p^c)^s)$ is an affine term stemming from the constrained momenta developed in Proposition 3.4. *The motion of an undulatory system must satisfy the fibre equations.*

Using the invariance of Eq. 3.8, we can separate the fibre equations into fibre and base components. First, rewrite Eq. 3.8 as

$$\omega_g(g, r)\dot{g} + \omega_r(g, r)\dot{r} = \tilde{\gamma}. \quad (3.9)$$

Invariance of Eq. 3.8 means $\omega_g(\Phi_h g, r)D_q\Phi_h = \omega_g(g, r)$ and $\omega_r(\Phi_h g, r) = \omega_r(g, r)$. Setting $h = g^{-1}$ in the former relation gives $\omega_g(g, r) = \omega_g(e, r)D_q\Phi_{g^{-1}} = \omega_g(r)g^{-1}$, while the latter relation implies that ω_r is independent of g . It can also be shown that $\omega_g(r)$ is invertible, and so Eq. 3.8 becomes

$$g^{-1}\dot{g} = A(r)\dot{r} + \gamma(r)p^c, \quad (3.10)$$

where g^{-1} represents the lifted action applied to vectors tangent to the fibre, and $\gamma(r)p^c = \omega_g^{-1}(r)\tilde{\gamma}$.

Practically speaking, the fibre equations, Eq. 3.8, play the most central role in the mechanics of undulatory locomotion. Formally, the connection is defined by setting $\tilde{\gamma} = 0$ in Eq. 3.8. If $\tilde{\gamma} = \gamma = 0$, then Eq. 3.10 describes the horizontal lift, i.e., the relationship between base vectors in $T_{\pi_2(q)}M$ and vectors in the full state space, T_qQ .

The relationship between the connection and the fibre equations can be interpreted as follows. Recall that $g^{-1}\dot{g}$ is an element of the Lie algebra, \mathfrak{g} , which physically corresponds to the velocity of the robot's body fixed reference frame (as seen by an observer in the body frame). The connection (described by $\tilde{\gamma} = \gamma = 0$ in Eqs. 3.8, 3.10) directly describes how internal shape changing motions, \dot{r} , lead to robot motion, $g^{-1}\dot{g}$. However, the moving robot may have built up some momentum due to previous motions. When there is no motion in the base space ($\dot{r} \equiv 0$), the robot's motion is driven solely by the momentum terms, γ . Thus, the fibre equations determine the robot's motion from the combination of built-up momentum and internal shape changes. They are formulated in a way which makes explicit each of these two contributions to locomotion.

However, the momentum terms in the fibre equations are themselves governed by the generalised momentum equation, Eq. 3.5. For the case of undulatory locomotion, where the constraints are assumed to be group invariant, it can further be shown that Eq. 3.5 is also invariant with respect to the group action.

3.7 Proposition: *Given a constrained mechanical system, define the function $P^c(q, \dot{q}) = \frac{\partial L}{\partial \dot{q}^i} (\frac{d}{dt}(\xi^c(q))_Q^i) = \frac{d}{dt}p^c$, where ξ_Q^c is a G -invariant vector field in \mathcal{S} and ξ^c is the Lie algebra-valued function over Q which generates ξ_Q^c . As a function on TQ , P^c is G -invariant. Thus, for all $g \in G$,*

$$P^c(\Phi_h q, T_q \Phi_h \dot{q}) = P^c(q, \dot{q}).$$

Practically speaking, this proposition implies that Eq. 3.5 can always be expressed strictly in terms of base variables and constrained momenta, i.e.,

$$\dot{p}^c = f(r, \dot{r}, p^c). \quad (3.11)$$

Example 2.2: (concl.) Combining the kinematic constraints and the constrained momentum, the fibre equations are:

$$W(g, r)\dot{g} - \begin{pmatrix} 0 \\ 0 \\ f(r)\dot{r} \end{pmatrix} = \begin{pmatrix} 0 \\ 0 \\ p^c \end{pmatrix},$$

where

$$W(g, r) = \begin{pmatrix} -\sin(\phi_b + \theta) & \cos(\phi_b + \theta) & -l \cos \phi_b \\ -\sin(\phi_f + \theta) & \cos(\phi_f + \theta) & l \cos \phi_f \\ ma & mb & \hat{J}_c \end{pmatrix}, \quad (3.12)$$

$$f(r) = \sin(\phi_b - \phi_f)(J_r, J_w, J_w).$$

The invariance of the constraints and the constrained momentum allows us to extract the group variables from Eq. 3.12. Letting e denote the identity group transformation, we have

$$\begin{aligned} W(e, r)g^{-1}\dot{g} &= \\ & \begin{pmatrix} -\sin \phi_b & \cos \phi_b & -l \cos \phi_b \\ -\sin \phi_f & \cos \phi_f & l \cos \phi_f \\ -2ml \cos \phi_b \cos \phi_f & -ml \sin(\phi_b + \phi_f) & \hat{J} \sin(\phi_b - \phi_f) \end{pmatrix} \begin{pmatrix} \cos \theta & \sin \theta & 0 \\ -\sin \theta & \cos \theta & 0 \\ 0 & 0 & 1 \end{pmatrix} \\ &= \begin{pmatrix} 0 \\ 0 \\ p^c - f(r)\dot{r} \end{pmatrix}. \end{aligned}$$

Finally, we can write this as

$$g^{-1}\dot{g} = A(r)\dot{r} + \gamma, \quad (3.13)$$

where

$$A(r) = \frac{1}{\det[W(e, r)]} \cdot \begin{pmatrix} 2l \cos \phi_b \cos \phi_f \\ l \sin(\phi_b + \phi_f) \\ -\sin(\phi_b - \phi_f) \end{pmatrix} \cdot f(r)$$

$$\gamma = \frac{p^c}{\det[W(e, r)]} \cdot \begin{pmatrix} 2l \cos \phi_b \cos \phi_f \\ l \sin(\phi_b + \phi_f) \\ -\sin(\phi_b - \phi_f) \end{pmatrix}.$$

The generalised momentum equation (Eq. 3.5) is

$$\dot{p}^c = m\dot{a}\dot{x} + m\dot{b}\dot{y} + \hat{J}\dot{c}\theta + J_r\dot{c}\dot{\psi} + J_w\dot{c}(\dot{\phi}_b + \dot{\phi}_f).$$

Using the invariant form of the connection, it is possible to rewrite this equation solely in terms of the base variables and the momentum:

$$\dot{p}^c = \frac{1}{2} \frac{d}{dt} \left(\log(-\det \omega_g(r)) \right) \cdot (p^c - f(r)\dot{r}) + \dot{f}(r)\dot{r},$$

where $\omega_g(r) = \omega_g(e, r)$ as defined in Eq. 3.9, and $\det \omega_g(r) = -(mR^2 + \hat{J})c$ which corresponds to the inertia of the board about the instantaneous centre of rotation (see Figure 3). Most importantly, however, notice that the dependence on the fibre variables has been completely eliminated from the generalised momentum equation. •

3.5. Summary and limiting cases. In summary, by using a geometric approach, and by using the symmetries and constraints which are natural to undulatory locomotion systems, we have reduced the system of n second order ODE's with k first order constraints (Eqs. 2.2 and 2.3) to a system of s first order (affine) constraints termed the fibre equations, $s - k$ first order generalised momentum equations (Eq. 3.11),

$$g^{-1}\dot{g} = A(r)\dot{r} + \gamma(r)p^c$$

$$\dot{p}^c = f(r, \dot{r}, p^c),$$

and a group of second order equations on the base space. This paper does not discuss the “reduced dynamics” on the base space, as these dynamics are not as important for the understanding of undulatory locomotion. Thus, the equations which are important to understanding undulatory locomotion are reduced to two first order equations that make explicit how internal shape changes and physical inertial lead to robot motion. We now briefly consider special cases of these equations that have occurred in previous work. For additional discussion of these ideas, the reader is referred to [Bloch, Krishnaprasad, Marsden, and Murray 1996, Kelly and Murray 1994].

Purely kinematic constraints

With a sufficient number of kinematic constraints, the system’s motion along the fibre is fully constrained. In this *kinematic case*, the connection takes the simpler form:

$$g^{-1}\dot{g} = A(r)\dot{r}. \quad (3.14)$$

Most commonly studied wheeled vehicles, such as Example 2.1, fall into this category. Eq. 3.14 describes a system on the fibre with no drift — a case that has been extensively studied in the literature on nonholonomic systems.

Pure symmetry constraints

There are no kinematic constraints in the cases of falling cats, satellites with rotors or attached robot arms, and platform divers. However, all of these systems have inherent Lagrangian symmetries, and therefore conserved momenta. In these cases, the fibre and generalised momentum equations take the form:

$$\begin{aligned} g^{-1}\dot{g} &= A(r)\dot{r} + \beta(g, r)\mu \\ \dot{\mu} &= 0. \end{aligned}$$

μ is the generalised momenta, and is constant. If $\mu = 0$, these equations reduce to Eq. 3.14. Using $A(r)$ it is clear how internal shape changes lead to net reorientation of the system. The use of fibre bundles and connections plays a primary role in understanding the mechanics and control of systems with *dynamic* constraints.

4. Discussion

Undulatory locomotors have no jets, thrusters, tracks, or legs to generate motion. Instead, motion is generated by a coupling of internal shape changes to external constraints. This paper has focused on systems with nonholonomic kinematic constraints. This class of systems includes not only the snakeboard, but also the “active cord” mechanism of [Hirose and Umetani \[1976\]](#), and any terrestrial undulatory robotic system that uses wheels to provide motion constraints. Also, many of the snake and worm-like systems discussed by [Chirikjian and Burdick \[1991\]](#) can be analysed using the techniques described here. Fish and some other undulatory mechanisms seem to use a similar principle to generate movement, but the constraints are more complicated than the ones considered in this paper. It is possible that our framework can be extended to include these systems as well. Furthermore, the same basic process seems to exist in legged locomotion, though the discontinuous nature of the dynamics makes it more difficult to analyse these types of systems from a classical standpoint.

A key observation in this work is that the constraints inherent in undulatory systems provide the means to determine motion as a function of internal shape change. When kinematic constraints are not sufficient to uniquely determine the robot’s motion, dynamic symmetries provide the additional constraints. of connections on principle bundles to describe the relationship between internal deformations and locomotive effect because the connection encompasses much of the information which is essential to locomotion. Using

these tools, we can parameterise the dynamics in terms of physically meaningful variables of generalised momenta, internal shape, and motion of the robot reference frame.

While this paper introduced a useful framework for studying undulatory mechanics, many open questions remain. *Controllability* of undulatory systems is a central issue that remains unresolved. Given an initial configuration, q_0 , and a final configuration, q_1 , an undulatory robot such as the snakeboard is said to be controllable if there exists a path connecting q_0 to q_1 which satisfies the robot’s dynamical equations. Using a principle fibre bundle framework, Kelly and Murray [1994] have recently derived a controllability test for systems which are described by the kinematic connection of Eq. 3.14. We believe that the formulation developed in this work will ultimately lead to an analogous controllability test for more general classes of systems which include dynamic constraints. Beyond the question of controllability lies the practical importance of developing *motion planning schemes* to generate feasible, or perhaps optimal, paths for undulatory motion planning problems. Finally, we wish to develop a better understanding of the concept of a “gait” in undulatory systems. For example, in [Lewis, Ostrowski, Murray, and Burdick 1994] it was shown that the snakeboard exhibits different “gaits” which generate motion. The geometric interpretation of these gaits is still unclear.

References

- Abraham, R. and Marsden, J. E. [1978] *Foundations of Mechanics*, 2nd edition, Addison Wesley: Reading, MA, ISBN: 978-0-8218-4438-0.
- Berkemeier, M. and Fearing, R. [1992] *Control of a two-link robot to achieve sliding and hopping gaits*, in *Proceedings of the 1991 IEEE International Conference on Robotics and Automation*, IEEE International Conference on Robotics and Automation, (Nice, France, May 1992), Institute of Electrical and Electronics Engineers, pages 286–292, DOI: [10.1109/ROBOT.1992.220249](https://doi.org/10.1109/ROBOT.1992.220249).
- Bloch, A. M., Krishnaprasad, P. S., Marsden, J. E., and Murray, R. M. [1996] *Nonholonomic mechanical systems with symmetry*, *Archive for Rational Mechanics and Analysis*, **136**(1), pages 21–99, ISSN: 0003-9527, DOI: [10.1007/BF02199365](https://doi.org/10.1007/BF02199365).
- Chirikjian, G. S. and Burdick, J. W. [1991] *Kinematics of hyper-redundant locomotion with applications to grasping*, in *Proceedings of the 1991 IEEE International Conference on Robotics and Automation*, IEEE International Conference on Robotics and Automation, (Sacramento, CA, Apr. 1991), Institute of Electrical and Electronics Engineers, pages 720–725, DOI: [10.1109/ROBOT.1991.131669](https://doi.org/10.1109/ROBOT.1991.131669).
- Hirose, S. and Umetani, Y. [1976] *Kinematic control of active cord mechanism with tactile sensors*, in *Proceedings of the 2nd International CISM-IFT Symposium on Theory and Practice of Robots and Manipulators*, International CISM-IFT Symposium on Theory and Practice of Robots and Manipulators, (Jadwisin, Poland, Oct. 1976), edited by A. Morecki and K. Kñedzior, pages 241–252.
- Kajita, S. and Tani, K. [1991] *Study of dynamic biped locomotion on rugged terrain—Derivation and application of the linear inverted pendulum mode*, in *Proceedings of the 1991 IEEE International Conference on Robotics and Automation*, IEEE International Conference on Robotics and Automation, (Sacramento, CA, Apr. 1991), Institute of Electrical and Electronics Engineers, pages 1405–1411, DOI: [10.1109/ROBOT.1991.131811](https://doi.org/10.1109/ROBOT.1991.131811).

- Kelly, S. D. and Murray, R. M. [1994] *Geometric phases and locomotion*, The Journal of Robotic Systems, **12**(6), pages 417–431, ISSN: 1097-4563, DOI: [10.1002/rob.4620120607](https://doi.org/10.1002/rob.4620120607).
- Kobayashi, S. and Nomizu, K. [1963] *Foundations of Differential Geometry*, volume 1, number 15 in Interscience Tracts in Pure and Applied Mathematics, Interscience Publishers: New York, NY, Reprint: [Kobayashi and Nomizu 1996].
- [1996] *Foundations of Differential Geometry*, volume 1, Wiley Classics Library, John Wiley and Sons: New York, NY, ISBN: 978-0-471-15733-5, Original: [Kobayashi and Nomizu 1963].
- Koditschek, D. and Bühler, M. [1991] *Analysis of a simplified hopping robot*, The International Journal of Robotics Research, **10**(6), pages 587–605, ISSN: 0278-3649, DOI: [10.1177/027836499101000601](https://doi.org/10.1177/027836499101000601).
- Koiller, J. [1992] *Reduction of some classical nonholonomic systems with symmetry*, Archive for Rational Mechanics and Analysis, **118**(2), pages 113–148, ISSN: 0003-9527, DOI: [10.1007/BF00375092](https://doi.org/10.1007/BF00375092).
- Lewis, A. D., Ostrowski, J. P., Murray, R. M., and Burdick, J. W. [1994] *Nonholonomic mechanics and locomotion: The Snakeboard example*, in *Proceedings of the 1994 IEEE International Conference on Robotics and Automation*, IEEE International Conference on Robotics and Automation, (San Diego, CA, May 1994), Institute of Electrical and Electronics Engineers, pages 2391–2400, DOI: [10.1109/ROBOT.1994.351153](https://doi.org/10.1109/ROBOT.1994.351153).
- McGeer, T. [1990] *Passive dynamic walking*, The International Journal of Robotics Research, **9**(2), pages 62–82, ISSN: 0278-3649, DOI: [10.1177/027836499000900206](https://doi.org/10.1177/027836499000900206).
- Raibert, M. H. [1986] *Legged Robots that Balance*, MIT Press: Cambridge, MA, ISBN: 978-0-262-18117-4.
- Shapere, A. and Wilczek, F. [1989] *Geometry of self-propulsion at low Reynolds number*, Journal of Fluid Mechanics, **198**, pages 557–585, ISSN: 0022-1120, DOI: [10.1017/S002211208900025X](https://doi.org/10.1017/S002211208900025X).
- Song, S. and Waldron, K. [1989] *Machines that Walk, The Adaptive Suspension Vehicle*, MIT Press: Cambridge, MA, ISBN: 978-0-262-51548-1.