

The Model of Perceived Organizational Support and Employee Involvement with Organizational Identification (OI) as a Mediating Variable

(A Study at PT. Jasa Raharja (Persero), Branch of Aceh Province, Indonesia)

Mahdani Ibrahim Muslim A. Djalil* Sofyan Idris T. Roli Ilhamsyah Putra
Faculty of Economics and Business Syiah Kuala University-Banda Aceh, Indonesia

Abstract

This study examined the impact of the perceived organizational support (POS) to the job involvement of employees (JI) with organizational identification (OI) as a mediator variable. Samples numbered 98 employees of PT. Jasa Raharja (Persero) Branch of Aceh, which was taken based on saturated samples (census). Primary data was obtained by the method of the distribution of questionnaires to all samples. Methods of data analysis using Structural Equation Modeling (SEM) with application Analysis of Moment Structures (AMOS). The results showed no influence perceived of organizational support on job involvement of employees, organizational identification acts as a mediating variable between perceived influence of organizational support and job involvement of employees. The analysis also found that organizational identification variable mediating role as full/perfect.

Keywords: Organizational Support, Job Involvement, Organizational Identification, Mediating Role

1. INTRODUCTION

The attainment of the goals and objectives of an organization largely determined by human resource aspect, because human resource is an important asset and very valuable in an organization. Human resource aspect is not only seen in terms of quality but also from the mental attitude of the human resource itself in running daily activities in an organization.

To enhance the role of employees as human resources in an organization is not without the efforts of the organization in conducting empowerment to employees, this can be done through the organizational support to them. Organizational support is a perception of employees to organization where they work, the extent to which these organizations pay attention to them in terms of welfare, protection, concern about health coverage and others which are about humanities (Rhoades & Eisenberg, 2002).

Indeed it has become a common philosophy that employees will be pleased to work if the support of organization to them is optimally implemented. Moreover, they will work in accordance with the organization's motives and not a few of employees who put aside their personal's matters for the organization. Thus, job involvement of an employee in the organization can be possibly made by the support of organization, which known as perceived organizational support/POS (Kurtessis et al., 2000). Without the good organizational support which are perceived by the employees, then it is not possible that the involvement level of employees will work as expected (Allam, 2000). Therefore, there is a causal relation between organizational support and employee involvement (Joshi, 1998).

PT. Jasa Raharja (Persero) Branch of Aceh Province is a company in the form of State-owned enterprises (SOEs) engages in the field of insurance, which gives priority to the implementation of Social Insurance and Mandatory Insurance Program that has to be in line with the needs of the community. Thus, PT Jasa Raharja (Persero) does the Public Transport Passenger Accident Insurance and Liability Insurance according to the law towards third parties as set in Regulation No. 33 and 34 in 1964. PT Jasa Raharja (Persero) has its head office in Jakarta in Jalan H.R. Rasuna Said Kav. C-2-Jakarta 12920. In addition, PT Jasa Raharja (Persero) also has branch offices at the provincial level throughout Indonesia, including Aceh. PT. Jasa Raharja (Persero) Branch of Aceh Province has 98 employees.

Employees of PT Jasa Raharja (Persero) Branch of Aceh Province are the company's assets. Through these employees, the company endeavor and strive to achieve optimal profit every year. Employees in the company are not only empowered to have certain qualities, but also they must have mental and spiritual that corresponds to the expectations of the company and customers. Better job involvement is desirable by management, however this will not realized by itself if the support of the organization not positively perceived by the employees, so that employees are slow, even lazy to be more creative to achieve the productivity. This research is to analyse the extent of the influence of perceived organizational support to the employee involvement in PT. Jasa Raharja (Persero) Branch of Aceh Province.

In line with statement above that the organizational support is one positive side if it is carried out

properly, the employees involvement is the other side that is expected by the company. Ideally, both sides are running properly, but the human elements that are exist within the company have different behavior one-another that often cause problems (Dutton, Dukerich, & Harquail, 1994). To answer this challenge, required the Organizational identification which is dimension of cognitive, affective, evaluative, and behavior of a person in attitude and action (Albert & Whetten, 1985).

Organizational Identification is starting from the social identity theory that assumes that the creation and improvement of the self concept is important in a group membership, because someone's status and employment is an important part of the lives of workers (Ashforth & Mael, 1989). If an employee with the organizational support that is already adequate but still minimum in job involvement, then the organizational identification can mediate the condition. The issue is does the organizational identification has been run in the organization, in this case is the PT Jasa Raharja (Persero) Branch of Aceh Province. This study is also about to see the role of Organizational Identification as a mediating factor in the relationship between organizational support and job involvement.

A phenomenon that often occurs is the employee involvement does not work as expected, despite the Organizational Support that has been optimally implemented. Organizational identification is one of the factors that can be expected to encourage the employee involvement in which turn can improve the performance of the organization. Therefore, researchers are interested in giving this research topic is "Organizational Support and Employee Involvement, Organizational Identification (IO) As Mediating Variable (Study On PT Jasa Raharja (Persero) Branch of Aceh Province).

Organizational support or known as the Perceived organizational support (POS) is the perception of employees about the concern or attention of an organization towards them as a form of support in order to make them work better. According to the POS theory, generally organizational support that is the extent of an organization appreciates their contributions and take care about their well-being (Eisenberger, Huntington, Hutchison, & Sowa, 1986; Rhoades & Eisenberger, 2002; Shore & Shore, 1995). In line with that view, Chen et al., (2009) said that the perceived organizational support is a fulfillment of needs of socio emotional which is used by employees to set up their organization in order to appreciate the efforts of the organization. Later, Rhoades and Eisenberger (2002) reviewed in the meta-analysis that POS is related to the antecedent of main hypothesis of the POS (Justice, the practice of human resources (HR), and the superiors support), attitude consequences (for example, affective organizational commitment, job satisfaction), and job achievement. Rhoades and Eisenberger (2002) added that the perceived organizational support is a global belief that was formed from a group of employees regarding to their assessment on an organization's policies and procedures. By some of the views mentioned above, can be understood that perceived organizational support is reciprocal efforts initiated by the organization and the employee, thus the organizational demand to the employee can be fulfilled and support each other, and vice versa.

Furthermore, the employee involvement in an organization is a phenomenon, in which generally employees are working wholeheartedly in accordance with the motives of the company so that it is a tribute to himself, but also not a few employees who overlook. There are several opinions about the meaning of job involvement. First, the job involvement is the level of job importance for someone for the person's self-image (Lodahl and Kejner; Lawler and Hall, in Blau and Boal, 1987). Second, the extent to which an individual participates actively in work (Allport; Bass, in Blau & Boal, 1987). Third, the extent to which pride of an individual perceived is influenced by the performance (French & Kahn; Gurin, Veroff, & Feld, in Blau & Boal, 1987).

According to Brown, in Muchinsky (2003) explains that the job involvement refers to the level in which a person is psychologically in favor to the organization and job is important as their own image. In line with the opinion, Robbins, (2007:309) agreed with Brown, that employees with a high level of job involvement, and he infuses in fields they are working, so that such employees will be fused into the job that they are doing, this things have a relation with the organizational citizenship behavior/OCB.

How the relationship between organizational support and employee involvement, Chen et al., (2009) explains that when an employee faces a difficult situation, then the organization will be looking for a good solution so that employee can do the tasks effectively and efficiently. Thus, Eder and Eisenberger, (2008) says that employee involvement arises as the moral responsibility of a job or response to the situation in the working environment. According to Dharmasari and Vathsala (2010) based on social exchange theory, employees always look at the favorable reactions of attitudes and behaviors from the organization that emerged from the exchange relationship that occurs between the individual and the management.

Based on the description above, it shows how important the organization concern towards the employees, likewise how important job involvement of employee with organizational support (POS). If employee believes that organization provides support that they need in accordance with their contribution and concern about the well being, then this can be predicted increases in job involvement, due to changes in the satisfaction received (Bhatia, Deep, & Sachdeva, 2012).

Organizational Identification defined by Mael and Ashforth (1992) as the togetherness perceived within an organization, experience of success and failure of the organization as their own. Dutton and Dukerich (1991) defines the Organizational identification as the shared beliefs and attitudes among employees toward the center, timeless and have different characteristics of the organization, which is one of the most important factors that are held by the employees and committed to the organization.

From the two opinions above about organizational identification, then we can understand that organizational identification is a positive self concept as member of the organization to get together to advance the organization and have to maintain his commitment to the organization. The concept of positive personal is also known as cognitive-conceptual or self definition in which employees and organization share love and sorrow, great organization because employees, and great employee is because organization or vice versa (Pratt, 1998, in Demir, 2015).

Tastana and Guceb (2014) examine organizational identification as mediating variable to the influence between the entrepreneurship employee behavior and organizational climate. Soenen and Melkonian (2016) examine justice and commitment to change, the organizational identification as mediating variables. In addition, Rim, Who, and Lee (1999) analyze strategic partner and corporate social responsibility (CSR) and the perceived organizational support and organizational identification as a mediating variable. Further organizational identification variables become the mediator between the supervisors support to the job satisfaction of secretary nurses in Turkey (Gok, Karatuna, & Karaca, 2015).

This study analyzes the influence of perceived organizational support to the job involvement and organizational identification variable as a mediator in the company PT Jasa Raharja (Persero) Branch of Aceh Province. From some views about mediating variable that have been explained above, then it can be made a model of the research and the research hypothesis as follows:

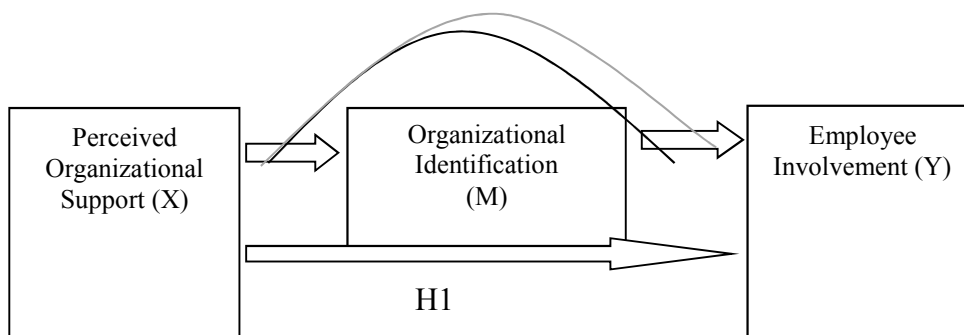

Figure 1: Research Framework

H1: There is the influence of perceived organizational support to employee involvement at PT Jasa Raharja Branch of Aceh Province.

H2: Organizational Identification moderates the influence between the perceived organizational support to employee involvement at PT Jasa Raharja Branch of Aceh Province.

2. RESEARCH METHODOLOGY

Based on theory and statistics applications, known two methods of data collection, census and sampling method. Census method is conducted on all population elements one by one. While the investigated sampling method is only the element sample of population (Supranto, 2008:23). Because of the population in this study is relatively small, then the primary data collection is done using census method. Thus, this research using census method in obtaining primary data of 98 employees as the unit of analysis.

This study uses two data sources namely, primary data and secondary data. Primary data collected with a questionnaire and distribute it to the respondent that the amount has been determined based on the census method. While secondary data collected by understanding related documents to the unit of analysis that is provided by PT Jasa Raharja (Persero) Branch of Aceh Province, such as number and condition of employees, history as well as the vision and mission of the organization. In addition, researchers also reviewed the literatures and books as well as articles in journal related to the analysis topic, which researchers collect in library and through online media.

This study analyzes the three constructs, namely the perceived organizational support, job involvement, and organizational identification. The construct of perceived organizational support using the 4 indicators developed by Rhoades and Eisenberger (2002) and Eisenberger et al. (1986), namely: (1) fairness, (2) supervisor support, (3) organizational rewards, (4) and job conditions, later developed into the 6 questions in the

questionnaire. Size of constructs job involvement using Lodahl and Kejner (Liao & Lee, 2009) version, namely: (1) the internalization of values about the goodness of the work, (2) the degree to which a person's work is worthwhile. Both indicators category modified into 6 question items as suggested by Lodahl and Kejner (Liao & Lee, 2009).

The constructs of organizational identification is using the 6 indicators that poured into the 6 questions in the questionnaire, developed by Mael and Ashforth (1992): (1) the typical of the organization, (2) the prestige of the organization, (3) competition between organizations, (4) internal competition organization, (5) satisfaction with the Organization, and (6) sentimentality. Every question of constructs indicators uses Likert scale with a score of strongly disagree/good/like = 1 to strongly agree/good/like = 5. The answers provided, respondents chose according to what actually happened or experienced based on their perception.

The primary data of study results were analyzed using Structural Equation Modeling (SEM) with application Analysis of Moment Structures (AMOS). SEM is a combination of two separate statistical methods, namely the factors analysis developed in the science of psychology and psychometric as well as the simultaneous equations model developed in the science of econometrics (Ghozali, 2011:77). SEM was used to test the validity and reliability of the instrument, test the influence of independent variables to the dependent variables, and test the direct and indirect influence of exogenous variables to endogenous variables. AMOS is one of the programs that are specifically designed to resolve the Structural Equation Modeling (SEM). In fact, there are many other similar programs such as EQS, LISREL, LISCOMP, STATISTICA and others. But AMOS is a program which widely used in Indonesia, even though the world, LISREL is used more by researchers (Anonymous, 2009).

3. RESULT AND DISCUSSION

In accordance with the statement of the hypothesis (H1) which stating that there is influence the perceived organizational support (X) to the employee involvement (Y), based on the results of the data analysis showed that there was no significant influence between (X) to (Y) as shown in table 1 below:

Table 1: influence of variable X to Y and M, as well as M to Y

Regression Weights: (Group number 1 - Default model)						
Variabel		Estimate	S.E.	C.R.	P	Label
M <-----	X	,43	,12	3,72	***	par_1
Y <-----	M	,23	,11	2,06	,04	par_2
Y <-----	X	-,03	,13	-,26	,80	par_3

Source: Primary Data (2015)

Table 1 shows the influence of the variable (X) to (Y) obtained the estimated value -0.03 which means, when there is an increase by 1 in the variable (X), then there is a decline of 0.03 on variable (Y). Then, Citical Ratio (CR) value of -0.26, which means under 0.001. CR = estimated value divided by standard error (S.E.) value, (CR = -0.03/0.13 = -0.26. CR is a comparison between t count with t table, therefore t count is smaller than the t table ($t_{count} < t_{table}$), this indicates an influence between variable (X) to (Y) is not significant. With -0.26 of CR value and 0.80 of probability value, in which the value is higher than expected probability, which is 0.05, then it can be stated that there was no influence between the variable (X) to (Y), so it can be concluded that H1 is not proven (rejected).

Furthermore, based on the results of the analysis in table 1 shows the perceived organizational support (X) influences on organizational identification (M) and variable organizational identification (M) also influences on employee involvement variable (Y), with a value of CR 3.72 and 2.06 respectively, this value is above zero (0) and significant at the level below 0.05, but the influence of these variables is not used as hypothesis by researchers.

H2: the organizational identification is mediating the influence between the perceived organizational support and employee involvement at PT. Raharja Services Branch of Aceh Province. Based on the result analysis of the study which is shown in table 2 indicate the presence of mediating variable role (M) to the influence of the variable (X) to (Y). In other words, the variable (X) has no direct effect on the variable (Y), but indirect influence occurs through mediating variables (M).

Table 2 in the column (X) and row (Y) has a value of 0.10, this means that indirect influences between variables (X) to variable (Y) is of 0.10 means when the X value rose by 1, with a mediating variable (M), then the Y value will increase by 0.1 on standard deviation.

Table 2: Analysis Result of the Influence of Mediating Variables (M)
Indirect Effects (Group number 1 - Default model)

Variabel	X	M
M	,00	,00
Y	,10	,00

Source: Primary Data (2015)

To see the magnitude of direct and indirect influence as well as total influence to analyzed variable, can be seen in table 3. Table 3B column (X) row (M) indicates a value of 0.43 which is a direct influence of variable (X) to variable (M) and direct influence of mediating variables (M) to variable (Y) by 0.23. So the influence indirect variables (X) to variable (Y) through the mediating variable (M) is $(0.43)(0.23) = 0.10$. This result is similar to that shown in table 3C (indirect effect) on a variable column (X) variable row (Y). Next, table 3B shows the direct influence of the variable (X) to variable (Y) of -0.03 and indirect influence of 0.10. So the total influence is $-0.03 + 0.10 = 0.07$. The results of this total influence is similar to that shown in table 3A (total effect) on the variable column (X) row (Y), namely of 0.07.

From the analysis results can be concluded that organizational identification variable (M) acts as a mediating variable on the influence perceived organizational support variable (X) and employee involvement variable (Y) by 0.10.

Table 3: Direct and Indirect Influence as well as Total Influence

A		
Total Effects (Group number 1 - Default model)		
Variabel	X	M
M	,43	,00
Y	,07	,23

B		
Direct Effects (Group number 1 - Default model)		
Variabel	X	M
M	,43	,00
Y	-,03	,23

C		
Indirect Effects (Group number 1 - Default model)		
Variabel	X	M
M	,00	,00
Y	,10	,00

Source: Primary Data (2015)

In addition, the direct and indirect influence as well as the total influence of analysis result can be described in a model of structural path analysis as a whole as shown in Figure 3 below:

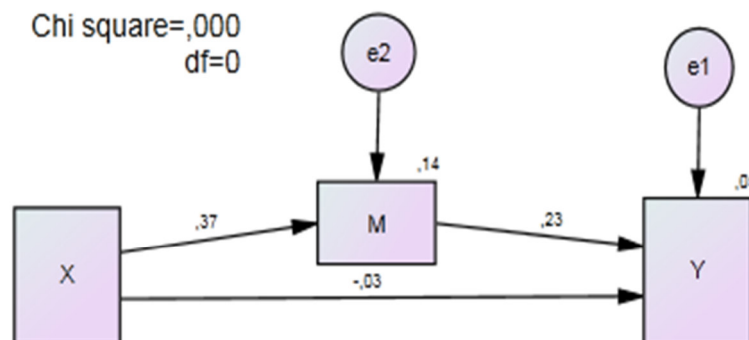

Figure 3: Structural path analysis Model

According to Baron and Kenny (1986), explain that the full/perfect mediation happens when the influence of the dependent variables to independent variable is not significant when interfered by mediating variable. The results of this study support the opinion, as analysis results found mediating variable mediates in full mediation to the influence of the variable (X) to variable (Y). In addition, this research results in line with the results of the research (Gok, Karatuna, & Karaca, 2015; Tastana & Guceb, 2014; Mael & Ashforth, 1992) which analyzed the role of the organizational identification as mediating variable.

As it known with good and suitable organizational support, then it can be predicted the possibility of employee will be more focus in their work. But, still we encounter the lacking of concern from employees about the objectives of the organization, so they often ignore their responsibilities, this is needed by organizational identification to reduces the habits which is not comply with the objectives of the organization, thus here sometimes appear to need organizational identification interfered between job involvement and organizational support.

4. CONCLUSIONS

1. Perceived organizational support does not have a significant effect on employee involvement at PT Jasa Raharja (Persero) Branch of Aceh Province.
2. Organizational Identification acts as a mediating variable that mediates the influence of perceived organizational support and employee involvement at PT Jasa Raharja (Persero) Branch of Aceh Province.
3. Organizational Identification role as mediating variable serves as a full intervening between perceived organizational support and employee involvement at PT Jasa Raharja (Persero) Branch of Aceh Province.

REFERENCES

- Albert, S. dan Whetten, D. 1985. Organizational Identity. *Research in Organizational Behavior*. 7: 263-295.
- Allam, Z. 2007. A Study of Relationship of Job Burnout and Job Anxiety with Job Involvement among Bank Employees. *Management and Labour Studies*. 32 (1) 136-145.
- Anonymous .2009. Statistic Consultant. <http://www.konsultanstatistik.com/2009/03/amos-for-sem.html> (accessed on 24-01-2017).
- Ashforth, B. E. dan Mael, F. 1989. Social Identity Theory and the Organization *The Academy of Management Review*. 14 (1), 20-39.
- Bhatia, A., Deep, G. dan Sachdeva, S. 2012. Organisational Effectiveness: An Empirical Study Among The Employees Of Punjab National Bank. *International Journal of Computing & Business Resea*. ISSN (Online): 2229-6166.
- Blau, G., dan Boal, K. B. 1987. Conceptualizing How Job Involvement and Organizational Commitment Affect Turnover And Absenteeism. *Academy of Management Review*. 12 (2), 288-300.
- Chen, Z., Eisenberger, R., Johnson, K. M., Sucharski, I. L., dan Aselage, J. 2009. Perceived Organizational Support and Extra-Role Performance: Which Leads to Which? *The Journal of Social Psychology*. 149 (1), 119-124.
- Cropanzano, R., Howes, J. C., Grandey, A. A., & Toth, P. 1997. The relationship of organizational politics and support to work behaviors, attitudes, and stress. *Journal of Organizational Behavior*. 18: 159-180.
- Demir, K. 2015. Teachers' Organizational Citizenship Behaviors and Organizational Identification in Public and Private Preschools. (Science direct). *Procedia - Social and Behavioral Sciences*. 174: 1176 – 1182. (doi: 10.1016/j.sbspro.2015.01.734).
- Dutton, J. E. dan Dukerich, J. M. 1991. Keeping an Eye on the Mirror: Image and Identity in Organisational Adaptation. *Academy of Management Journal*. 34: 517–554.
- Dutton, J. E., Dukerich, J. M. dan Harquail, C. V. 1994. Organizational Images and Member Identification. *Administrative Science Quarterly*. 39 (2), 239-263.
- Eder, P. dan Eisenberger, R. 2008. Perceived Organizational Support: Reducing the Negative Influence of Coworker Withdrawal Behavior. *Journal of Management*. 34 (1), 55-68 (DOI: 10.1177/0149206307309259).
- Ghozali, Imam. 2011. *Multivariate Application Analysis with SPSS Program*. Semarang, Indonesia: Universitas Diponegoro Publication Agency
- Eisenberger, R., Huntington, R., Hutchison, S., dan Sowa, D. 1986. in Gok, S., Karatuna, I., and Karaca, P. O. (2015). The Role of Perceived Supervisor Support and Organizational Identification in Job Satisfaction. *Procedia - Social and Behavioral Sciences*. 177: 38-42. (ScienceDirect), doi: 10.1016/j.sbspro.2015.02.328.
- Organizational Support. *Journal of Applied Psychology*. 71: 500–507.
- Joshi, G. 1998. Job Satisfaction, Job Involvement and Work Involvement among the Employees of Private and

- Public Sectors. *Psychological Studies*. 43 (3), 85-90.
- Kurtessis, J. N., Eisenberger, R. Ford, M. T. Buffardi, L. C. Stewart, K. A., dan Adis, C.S. 2015. Perceived Organizational Support: A Meta-Analytic Evaluation of Organizational Support Theory. *Journal of Management*. 20 (10), 1-31. (DOI: 10.1177/0149206315575554).
- Liao, Chi-Shun., dan Lee, Cheng-Wen. 2009. An Empirical Study of Employee Job Involvement and Personality Traits: The Case of Taiwan. *Int. Journal of Economics and Management*, 3 (1), 22 – 36.
- Mael, F. dan Ashforth, B. 1992. Alumni and Their Almaters: A Partial Test of the Reformulated Model of Organizational Identification. *Journal of Organizational Behavior*, 13, 103-123.
- Muchinsky, P.M. (2003). *Psychology Applied to Work. 7th Edition*, Wadsworth, Belmont.
- Rhoades, L., dan Eisenberger, R. 2002. Perceived Organizational Support: A Review of the Literature. *Journal of Applied Psychology*. 87 (4), 698–714. DOI: 10.1037//0021-9010.87.4.698.
- Rim, H., Yang, S-Un., dan Lee, J. 2016. Strategic Partnerships with Nonprofits in Corporate Social Responsibility (CSR): The Mediating Role of Perceived Altruism and Organizational Identification (Abstract). *Journal of Business Research*. 69 (9), 3213-3219. Abstract. Science Direct, available online, September 2016.
- Robbins, S.P. dan Judge, T. A. 2007. *Organization Behavior. 12th Edition*. Translated by: Diana Angelica. Jakarta, Salemba Empat Publishing Agency
- Shore, L. M., dan Shore, T. H. 1995. Perceived Organizational Support and Organizational Justice. In R. S. Cropanzano dan K. M. Kacmar (Eds.), *Organizational Politics, Justice, and Support: Managing the Social Climate of the Workplace* (149–164). Westport, CT: Quorum.
- Soenen, G. dan Melkonian, T. 2016. Fairness and Commitment to Change in M&As: The Mediating Role of Organizational Identification. *European Management Journal* (ScienceDirect), available online 29 November 2016.
- Supranto, J. 2008. *Statistic: Theori and Aplication. 7th/ Edition*. Jakarta, Erlangga Publishing Agency
- Tastana, S.B. dan Gucelb, C. 2014. Explaining Intrapreneurial Behaviors of Employees with Perceived Organizational Climate and Testing the Mediating Role of Organizational Identification: A Research Study among Employees of Turkish Innovative Firms. *Procedia - Social and Behavioral Sciences*. 150: 862 – 871. (Science direct), doi: 10.1016/j.sbspro.2014.09.095.