

NASA Technical Memorandum 89856
AIAA-87-1098

The NASA Electric Propulsion Program

David C. Byers
Lewis Research Center
Cleveland, Ohio

and

Robert A. Wasel
NASA Headquarters
Washington, D.C.

(NASA-TM-89856) THE NASA ELECTRIC
PROPULSION PROGRAM (NASA) 22 P CSCL 21H

N87-21037

G3/20 Unclass
43587

Prepared for the
19th International Electric Propulsion Conference
cosponsored by the AIAA, DGLR, and JSASS
Colorado Springs, Colorado, May 11-13, 1987

The NASA logo, consisting of the word "NASA" in a bold, sans-serif font.

THE NASA ELECTRIC PROPULSION PROGRAM

David C. Byers*
National Aeronautics and Space Administration
Lewis Research Center
Cleveland, Ohio 44135

and

Robert A. Wasel*
NASA Headquarters
Office of Aeronautics and Space Technology
Washington, D.C. 20546

Abstract

The NASA OAST Propulsion, Power, and Energy Division supports electric propulsion for a broad class of missions. Concepts with potential to significantly benefit or enable space exploration and exploitation are identified and advanced toward applications in the near to far term. This paper summarizes recent program progress in mission/system analyses and in electrothermal, ion, and electromagnetic technologies.

Introduction

Prospects now appear high for broad acceptance and application of electric propulsion systems. Low power, pulsed plasma thrusters are in use for very precise orbit control¹ on Navy NOVA spacecraft and 500-W class augmented hydrazine resistojets are operational on many geosynchronous communication satellites.² These first applications have provided users with considerable information on the integration requirements and potentials of electric propulsion and are important milestones toward its full exploitation.

Multipropellant resistojets³ have been selected for the Initial Operating Capability (IOC) Space Station⁴ as their use nearly eliminates the necessity for both launch of drag make-up propellants and, importantly, the return of waste fluids from Station subsystems. The use of high power, primary electric propulsion was strongly endorsed by the report of the National Commission on Space.⁵ Applications cited therein included both Earth-orbit and planetary cargo transfer vehicles. Large solar⁶ and nuclear⁷ space power systems, whose lack of availability has long prevented the realization of primary electric propulsion, are now under development for space demonstration and/or use in the 1990's. In addition to these developments, recent^{8,9} and planned^{10,11} space tests give further evidence of the interest, and will, of various agencies to develop electric propulsion.

The NASA electric propulsion program supports both system and mission analyses and research and technology efforts on several propulsion concepts. Studies are aimed at defining the requirements for, and impacts of, advanced propulsion for a broad range of applications from low power auxiliary functions to large cargo transfer vehicles. The requirements of the many applications and missions are often very disparate. The program, therefore, addresses a range of technologies in the areas of electrothermal, ion, and electromagnetic propulsion.

*Member AIAA.

The following highlights selected accomplishments in the analysis and technology areas to illustrate program content and direction.

Mission and System Analyses

Recent studies have analyzed electric propulsion systems and applications ranging from 1 kW class concepts for stationkeeping to several-hundred-megawatt Nuclear Electric Propulsion Systems (NEPS) for Earth-orbit and planetary missions. For completeness, some studies sponsored by agencies other than NASA will be presented.

Schreib,¹² in a review of the INTELSAT sponsored xenon ion propulsion program, evaluated the integration issues and cost benefits of ion systems on three-axis and spin-stabilized communication satellites. Table 1, from Ref. 12, shows the calculated net mass and cost benefits for such spacecraft, where direct solar array power was used, if required, to supplement the 2.0 kW-hr energy supplied by batteries used for equinox operations. The net benefits are very large and approach the cost of typical communication satellites in some cases.

As previously noted, multipropellant resistojets were baselined for the IOC Space Station. Interest in these systems arose⁴ from their strong synergism with other Station subsystems, such as the Environmental Control and Life Support System (ECLSS), and other advantages accruing from low thrust levels and the use of gaseous, benign propellants. Large life cycle cost savings are projected^{13,14} for Space Station by use of resistojet systems which are described in detail in Ref. 15. In the long run, selection of the multipropellant resistojets may well represent an important step in the development of integrated on-board propulsion systems which can provide large potential benefits to launch, orbit transfer, and space systems.

Palaszewski¹⁶ systematically evaluated the use of various electric propulsion concepts for a variety of functions on polar and co-orbiting free flyer spacecraft. Table 2 shows the propellant masses¹⁶ required for servicing of several co-orbiting space systems. The mission velocity increments were extremely sensitive to the altitudes and servicing intervals chosen and values of those were selected to minimize the propulsion requirements. The very large potential benefits of electric propulsion for servicing co-orbiting free flyers is clearly shown in Table 2 as, dependent on the technology assumed, up to an order of magnitude reduction in propellant, relative to the baseline hydrazine system, can be realized. As discussed in Ref. 16, low acceleration requirements exist for

several free flyer missions. In those cases, low thrust electric propulsion offers advantages beyond the propulsion mass reductions discussed above.

Perhaps stimulated by the SP-100 program,⁷ NASA^{17,18} and Air Force¹⁹ sponsored efforts were conducted to evaluate NEPS for several missions. Sercel and Krauthamer¹⁷ conducted a detailed study of NEPS for LEO-GEO, Lunar Base, and Neptune Orbiter missions. In that study the impacts of power level and electric propulsion technology (MPD and ion) on mission performance were obtained and compared with advanced chemical propulsion. Figures 1(a) and (b) show the transportation mass per mission and average trip times,¹⁷ assuming MPD propulsion systems, as a function of NEPS power level for LEO-GEO and Lunar Base missions, respectively. Below 1.0 MWe, the power and ion propulsion system specific mass was assumed to be 25 kg/kW. Above 1.0 MWe, the power and MPD propulsion system specific mass was assumed to be 6 kg/kW. The performance of an advanced (485 sec specific impulse, space based, aerobraked) chemical system was also evaluated and the transportation mass per mission was about 30 and 75 metric tons per mission for the LEO-GEO and Lunar Base missions, respectively. The potential saving in transportation mass provided by NEPS, relative to advanced chemical systems, ranged for both missions from a factor of two, for high power, to a factor of six, for the lowest NEPS power level studied. The high power NEPS systems did, however, enable significant reduction in trip times which could be of great importance in overall mission designs and costs. Figure 2 shows the Neptune Orbiter mission trip time¹⁷ for the two power regimes with ion and MPD systems. For comparison, single Space Shuttle missions using hydrogen/oxygen propulsion systems have been shown²⁰ to require from 15 to 20 yr for this mission. It can be seen that NEPS can save from about 3 to 10 yr trip time, dependent on power level, and that the ion system trip times are about 1.5 yr shorter than those with MPD systems. Reference 17 also evaluated very high power NEPS for manned missions to several planets. Trip times for 200 MWe NEPS, minimized by selection of appropriate specific impulses, of about six months, two years, and seven years were obtained for round trips to Mars, Jupiter, and Neptune, respectively.

Reference 18 presented parametric estimates of the dry masses of resistojets, arcjet, and ion propulsion systems and the mission performance (velocity increments and thrusting times) that could be obtained with the assumption of a single Shuttle launch of an SP-100 power system. Figure 3 shows the mass breakouts, for an assumed 300 kWe SP-100 system, for the three electric propulsion systems. In all cases, the propulsion system dry mass was a small fraction of the Shuttle Orbiter payload. The xenon ion system dry mass was heavier than that of either the resistojets or arcjet system but, due to higher specific impulse, could deliver significantly more velocity increments and thrusting times (Figs. 4(a) and (b)).

As a final example of mission analyses, an Air Force study¹⁹ evaluated a reusable NEPS for the delivery of a galaxy of 28 Global Positioning System (GPS) satellites, to a 20 187 km orbit. Table 3 shows estimated overall galaxy deployment costs for several propulsion systems. The cost savings estimated in Ref. 19 are very great, in large part due

to the reusability of the NEPS, which much more than offset the higher initial cost of the NEPS with respect to the other, chemical, systems.

In general, the studies cited have affirmed the great leverage that can be provided by electric propulsion systems for a very broad class of missions. Benefits can be realized in a number of ways including major reductions of: (1) mission life cycle costs, (2) propellant masses, and (3) orbit transfer times for planetary missions, and/or large extensions of on-orbit lifetimes.

Electrothermal

Efforts in electrothermal propulsion include multipropellant resistojets for Space Station, high performance resistojets for spacecraft, low power DC arcjets, and research on high power thruster concepts.

Multipropellant Resistojets

Presently, multipropellant resistojets are planned for drag make-up propulsion on the IOC Space Station (Fig. 5). A number of technical issues were addressed in order to provide the confidence required for that selection. Grain stabilized platinum was selected³ for the heat exchanger and nozzle and many tests were performed^{21,22} in material test cells to verify the compatibility of the stabilized platinum with candidate propellants. Figure 6 shows some details of that test program which now includes over 20 tests of 1000 hr, or greater, duration on CO₂, CH₄, H₂, NH₃, N₂, H₂O (steam), and N₂H₄. Sample temperatures were held at 1400 °C except for methane and hydrazine for which lower temperatures were used, respectively, to avoid decomposition and simulate the output of a hydrazine catalyst bed. The calculated lifetimes, based on a criterion of a 10 percent mass loss and an assumption of linear mass loss with time, were generally over 1x10⁵ hr (Fig. 6). These lifetimes are far greater than required for the Space Station application. Further life verification tests included the recent completion²³ of a 2000 hr/2400 thermal cycle test of a laboratory model platinum resistojets operated on CO₂. This test confirmed many of the processes planned for the flight thruster, such as diffusion bonding and welding, and provided information on phenomena such as grain growth as a function of temperature and materials treatment.

The potential impacts of plumes were of high interest to various potential users of the Space Station. A program was, therefore, initiated²⁴ to characterize the upstream and downstream plumes of the multipropellant resistojets. Accurate determination of low level flow fields, especially upstream of the nozzle, is an extremely difficult process and was found to require very high pumping speed vacuum chambers, using large amounts of cryogenics, and special test equipment, such as precision temperature controlled quartz crystal microbalances. The plume characterization effort is still in progress but initial results (Fig. 7) are promising in that reasonable agreement has been obtained between measurements and simple plume predictions²⁴ of the downstream plume shapes.

Several engineering model^{3,15} resistojets have been fabricated and tests are underway to characterize the performance, thermal properties, and

electrical interfaces as a function of propellant type and power level. The Space Station power distribution is now planned to be about 208 V at 20 kHz. Gruber²⁵ has designed and integrated a power processor concept which provides electrical isolation and 20 kHz to the thruster. The power processor is extremely simple, consisting of less than ten parts, and limits inrush currents in order to minimize thermal/mechanical shocks on startup.

High Performance Resistojets

Efforts are underway to increase the specific impulse of low power, hydrazine resistojets from the 300 sec level, presently available,² to 335 sec and greater. Analytical and experimental studies of fundamental phenomena, of special importance at low Reynolds number conditions, are in progress, along with efforts to design and verify the performance and lifetimes of high specific impulse resistojets.

The Reynolds numbers of resistojet, and arcjet, nozzles are very low, typically less than 2000 to 3000. As a consequence, boundary layers are thick and the flow fields will be very different from potential flow situations. Calculations have been initiated²⁶ of the nozzle flows and an example, for a Reynolds number and expansion ratio of 10^3 and 10^2 , respectively, is shown in Fig. 8. The thick boundary layers are evident and, as has been typically found, the Mach number peaks near the throat region. As much of the flow is subsonic, ambient vacuum facility conditions can potentially affect observed performance. Tests to determine ground test effects are underway.²⁷ The thrust levels of a single resistojet, operated at various flow rates of heated and unheated nitrogen, were directly measured and the usual thrust correction to account for ambient pressure was then applied. The corrected specific impulses of unheated flows were unaffected by the facility pressure over the range evaluated. With heated flows, however, there was a consistent increase of corrected specific impulse, up to 7 percent, as the pressure was reduced to less than about 5 μ m. At present, it is felt that the observed behavior is due to heat transfer effects and work is continuing to establish general criteria for correction of thrust measurements for very low pressure operation.

Experimental evaluations of low Reynolds number nozzles are also in progress.²⁸ Unheated hydrogen and nitrogen are being tested with bell, conical, and trumpet shaped nozzles over ranges of expansion ratios, divergence angles, and Reynolds numbers from 25 to 200, 15° to 25° , and 500 to 6000, respectively. In general, little variation of nozzle efficiency with nozzle design was observed at Reynolds numbers above about 1500. Although preliminary, at lower Reynolds numbers the trumpet and conical nozzles appear to show better performance than the bell nozzles, with the difference increasing with decreasing Reynolds numbers.

Component tests for high temperature resistojets are underway and a design with potential for a mission average specific impulse above 335 sec has been completed by the Rocket Research Company.²⁹ The concept will use: (1) a pressurized heater cavity to reduce sublimation, (2) rhenium for improved creep rupture, and (3) high temperature stable surface texturing to increase heat transfer

efficiency over the life of the resistojet. At present, plans are to test a precursor design in mid 1987 to validate design concepts prior to fabrication and tests of a flight type thruster in late 1987.

Low Power DC Arcjets

The NASA arcjet program has concentrated to date on low power DC arcjets which are candidates for auxiliary propulsion. It should be noted that the Air Force sponsored arcjet program has concentrated on high power, approximately 30 kW, DC arcjets.³⁰⁻³² A strong interaction in arcjet technology is maintained between the Air Force and NASA via a Memorandum of Agreement (MOA) between the Air Force Rocket Propulsion Laboratory and the NASA Lewis Research Center. This interaction fosters rapid interchange of information, which is of importance due to the generic applicability of many findings of the Air Force and NASA arcjet programs.

In initial tests with state-of-the-art, low power arcjets,³³ startup was very erratic and was often accompanied by significant cathode and anode erosion. Typically, startup would be accompanied by sparking during arc ignition and very unstable volt-ampere arc characteristics subsequent to arc ignition. The flow fields in the heat exchanger were changed to include a strong vortex. Additionally, a power processor which used pulsed startup and very rapid response circuits was designed and implemented.³⁴ These two changes, along with minor geometric variations, resulted in reliable, nondamaging arcjet startups (Fig. 9). Subsequently, over 300 starts were demonstrated on a 1 kW arcjet.^{35,36} The conditions of the electrodes were evaluated periodically during the startup test program and it was observed that both the cathode shape and the electrical startup characteristics became constant after a few starts and did not significantly change for the duration of the testing. It was also found that the flow field and power processor changes led to decreased cathode erosion during steady state operation (Fig. 10).

Arcjet performance tests were performed with hydrazine and hydrogen/nitrogen mixtures over a wide range of flow rates, power levels, and geometries. It was found that the specific impulse was nearly specified by the ratio of power to mass flow rate for many thruster geometries (Fig. 11) and values of specific impulse between 400 and 730 sec were demonstrated with hydrazine propellant.³⁷ An attractive feature of arcjet systems is their potential for use of space qualified subsystems. This commonality was verified by the successful integration of an arcjet with the catalyst bed, propellant management components, and mounting structure used with operational resistojets.³⁷

Arcjets used for N-S stationkeeping will be required to operate between about 200 and 300 hr. Life tests of 100 hr on hydrogen-nitrogen gas mixtures and 40 hr on hydrazine have been performed on laboratory, 1 kW class arcjets.³⁸ After an initial burn in period, wherein the cathode assumed an equilibrium shape, the thruster run on gas mixture performed with negligible change in arc characteristics. The hydrazine arcjet exhibited an increasing arc voltage during the tests. Efforts are underway to determine the cause of the performance

variation observed during the hydrazine life test and preliminary indications are that it was due to the design used, as opposed to any special effects of hydrazine.

High Power Thrusters

Research was performed on pulsed and microwave electrothermal thrusters. Interest in these devices arises from their special characteristics which promise high performance and long lifetimes at very high levels of power. The Pulsed Electrothermal Thruster (PET) alone, of present electric propulsion concepts, operates at pressures (200 to 1000 atm) high enough to allow recovery of molecular inelastic energy losses. This feature offers the promise of uniquely high efficiencies at specific impulses from 1000 to 1500 sec. Strong progress was made in PET research by the demonstration³⁹ of operation on water at an average power level of 500 to 600 W. Efficiencies in excess of 0.5 were achieved at a specific impulse of 1400 sec and indications were that efficiencies as high as 0.75 might be achieved through operation at higher power and in lower pressure facilities.

Research has continued on the microwave electrothermal thruster.⁴⁰ This concept offers promise in that it has been demonstrated that microwave energy can be very efficiently transferred to a gas. Additionally, plasmas can be suspended away from direct contact with electrodes. These two features may allow very high power densities to be maintained consistent with wall temperatures appropriate for long life. Microwave energy coupling efficiencies up to 0.98 have been achieved with nitrogen and helium at powers up to 2 kW and plasma temperatures and densities have been directly measured. Additionally, a number of interesting spin-off applications of microwave plasma heating have been identified, including atomic oxygen sources and material processing.

Ion

Efforts in ion propulsion included work on thruster R&T, auxiliary propulsion developments, and system technologies.

Thruster R&T

Strong advances were made in the performance modeling of multipole ion thrusters. Brophy and Wilbur, in a series of publications,⁴¹⁻⁴⁴ have provided both theoretical analyses and experimental results to validate and illuminate their models. A single algebraic equation was developed⁴¹ to predict the beam ion energy cost as a function of propellant utilization in terms of four parameters essentially specified by the thruster geometry and propellant type and the two controllable operating parameters: propellant flow rate and discharge voltage. For discharge voltages above propellant dependent values, this model correctly predicted⁴² observed variations in beam ion energy production costs as a function of propellant type, ion beam extraction area, discharge voltage, transparency of ion optics to neutral propellant, and discharge chamber wall temperature.⁴³ The basic performance model⁴¹ was then extended⁴⁴ in order to allow prediction of primary electron densities and Maxwellian electron densities and temperatures. Experiments performed with argon and xenon propellants were in

good agreement⁴⁴ with the predicted plasma properties. These efforts are important in that the general impacts of variations in multipole thruster geometries and operating points can now be estimated with a fidelity not previously available.

Due to the major benefits of high power thrusters for high power systems¹⁸ efforts continue to extend the operating envelopes of both divergent field and multipole inert gas thrusters. Xenon, 30-cm thrusters have been operated⁴⁵ for several hundred hours at 10 kW and components, such as cathodes,⁴⁵ capable of operating at significantly increased emission currents, have been demonstrated (Fig. 12). Designs of 50-cm thrusters have been completed and the tooling required to fabricate appropriate ion optics, the highest risk element in 50-cm thruster demonstration, has been completed and blanks of stainless steel and molybdenum successfully dished.

Auxiliary Propulsion Developments

Both 8-cm Ion Auxiliary Propulsion System (IAPS) mercury ion thruster systems were removed from the DOD spacecraft, successfully test fired, and reinstalled on the spacecraft. The space test now awaits a flight opportunity on the Space Shuttle Orbiter.

Efforts to determine the wear mechanisms of the INTELSAT/Hughes Research Laboratories (HRL), 25-cm, xenon ion thruster⁴⁶ are nearing completion. In a test co-sponsored by INTELSAT, HRL, and NASA, the ion thruster has accumulated over 4400 hr and 3700 cycles at nominal power and thrust levels of 1.3 kW and 65 mN, respectively. Electrical power and propellant are supplied by the simplified power processor and flight type pressure regulator described in Ref. 46. The hours and cycles already achieved are well in excess of those required for 10 years of N-S stationkeeping, by a single thruster, of an INTELSAT VI class spacecraft.

Systems Technology

Work is underway at JPL to address issues which are important to ion propulsion systems and to evaluate system considerations which affect subsystem and component technology requirements.

Simpler, more reliable ion systems result from both decreasing the number of thruster/power processor units, by increasing the power per thruster, and operating on xenon propellant. For those reasons, the 2.7 kW J-Series mercury thruster was modified to operate at 5 kW on xenon. Modifications necessary to affect those operating changes included: (1) removal of all insulating materials subject to high temperature degradation including kapton, teflon, and vespel, (2) development of a new, high voltage xenon propellant isolator, (3) use of solid ground screens, and (4) implementation of very compliant ion optics mounting systems.⁴⁷ Further system simplification has been accomplished through the use of a central neutralizer subsystem. This system consists of two neutralizer cathodes. Only one neutralizer is used at a time to neutralize the ion beams from both engines. The second cathode is included for redundancy.

To provide reliable on-command engine and neutralizer cathode ignition, a gas pulse starting

system was developed. This system uses the simultaneous application of 500 V to the keeper electrode and a short duration gas pressure pulse through the cathode to assure transition through the Paschen breakdown criterion. The use of this system also eliminates the need to precondition the cathode insert after exposure to air.

To assure an engine lifetime of 15 000 hr, techniques by which the internal sputter erosion may be reduced are being investigated.⁴⁸ This includes primarily looking at the effect of the addition of small amounts of other gases such as nitrogen to the propellant to inhibit sputtering. Erosion rates are measured by exposing a section of material polished to a mirror finish to the engine discharge chamber plasma for up to 12 hr and then measuring the etch depth with a profilometer.

An ion propulsion module using two, 5 kW, xenon ion thrusters has been developed as a test bed for systems technology⁴⁹ and is shown in operation in Fig. 13. A computer control system was developed to operate the propulsion module autonomously (Fig. 14). The computer control system can simultaneously or sequentially start any combination of the two engines and two neutralizer cathodes. In addition, the capability to throttle an engine under computer control between a beam current of 0.75 and 4.0 A has been demonstrated. During normal operation the computer control algorithms provide proportional control of the discharge current and cathode flow rate to maintain the beam current and discharge voltage set points. The main flow rate is varied along with the cathode flow to maintain the desired propellant utilization efficiency. Any of the set points (beam current, discharge voltage, propellant efficiency and beam voltage) may be changed from the computer keyboard during engine operation. This allows flexibility in throttling the engine that has never been available before. In addition, the engine gimbal system is also under computer control and the gimbal angle may be selected from the keyboard during operation. Finally, the program can be operated in a mode in which it will read preprogrammed commands stored on a magnetic disk. The computer will then execute these commands, such as start-up, throttle, etc., as a function of "mission time."

The implementation of concepts which simplify and increase the reliability of ion systems, along with demonstration of those concepts in multi-thruster systems with flight type control philosophies, is an important step toward ultimate acceptance of ion systems for major space missions.

Electromagnetic

In the electromagnetic area, research is underway to provide understanding of the phenomena controlling electromagnetic propulsion, and to explore thruster concepts with potential for operation at very high power levels.

Major advances in plasma thruster theory have recently been made at Princeton University. For the first time, a universal description of pure electromagnetic (MPD) thruster voltage/current terminal behavior has been obtained.⁵⁰ The model has been verified over a wide range of thruster propellant types, propellant flow rates, and thruster geometries (Fig. 15).

A characteristic current, J_{FI} , at which full ionization occurs in coaxial plasma thrusters, has been defined in terms of first principles. At currents below J_{FI} , the hybrid regime, the plasmas are partially ionized and based on extensive reviews of plasma thruster performance, the ion velocities appear to be limited to Alfvén speeds. At currents above J_{FI} , the fully ionized regime, the analyses indicate that thruster efficiencies, based on electromagnetic force contribution only, may be limited to values less than achievable in the hybrid regime. Based on these results, efforts are now underway to explore the performance potentials of thrusters operated in the hybrid regime, which represents the transition operating mode between high pressure electrothermal and fully ionized plasma thrusters.

Experiments also revealed both the highly non-equilibrium nature of coaxial plasma thrusters and the presence of plasma waves which are central to their operation. A generalized criterion for electron superthermalization by the observed plasma waves was identified and shown to be present in coaxial thrusters. In order to better understand plasma wave phenomena, experiments were implemented which allow direct evaluation of the wave frequencies as a function of wavelength, or wave dispersion relationships (Fig. 16).

Additionally, a steady state coaxial plasma thruster facility is now operational that allows steady state thruster operation at power levels up to 40 kW at propellant flow rates up to 8×10^{-3} kg/sec and background pressures less than 5×10^{-4} torr. These new experimental capabilities will provide insights into the importance of plasma instabilities to thruster behavior and the potential performance and life levels of hybrid plasma thrusters.

Under Air Force sponsorship, Princeton University has developed⁵² and refined a nuclear surface layer activation (SLA) measurement for in-situ measurement of MPD thruster component erosion. Recent efforts have improved calibration and data management techniques and resolution of erosion depths of about 0.25 μ m are now possible. The SLA technique has been established and is an excellent candidate for in-situ erosion rate measurements in many electric propulsion devices in which there are hostile environments and very low erosion rates.

Efforts are also ongoing⁵² at JPL to provide the technology required for multimegawatt MPD thrusters for high energy applications such as cargo vehicles for Earth-orbit transfer and Mars missions. The approach taken has been to define and test a progression of subscale MPD thrusters of increasing power level. Testing is now underway with a thruster sized to operate at power and arc current levels up to 100 kW and 3000 A, respectively (Fig. 17). The thruster has operated for a total of 8.5 hr during 72 tests of up to 55 min duration. The highest power level attained to date was 72 kW at an arc current of 1700 A. No performance data have been taken as performance is expected to be poor at these arc current levels which are relatively low for the self field MPD concept. However, the plasma densities and temperatures demonstrated are projected to be similar to those of full scale, megawatt engines.

Lifetime and reliability are key issues in the subscale MPD test program. In that regard, recent

experimental findings pertaining to: (1) startup procedures, (2) the cathode-insulator interface, and (3) cathode temperatures are presented.

The startup process is found to be critical in that a cold start always entails erosion of the cathode, and usually the nearby insulator. Once a significant asymmetry in either the cathode or the insulator shape develops, a symmetric, stable arc is almost impossible to obtain. A smooth, non-destructive starting technique has been devised. This employs an auxiliary set of gas injection jets to support a 800 W glow discharge. This discharge heats the cathode to incandescence at which point the main power may be applied, without any visible erosion.

The cathode-insulator interface is a location of particularly high power density and heat loads in the MPD thruster. Testing has shown that the arc on the cathode tends to burn underneath the insulator causing rapid insulator erosion. An electrically isolated buffer electrode has been found to solve the problem. When placed within a distance estimated to be smaller than the cathode sheath, the buffer electrode effectively prevents arc damage to the insulator.

Finally, cathode tip temperatures have been measured and found to be within a reasonable upper limit (1800 to 1900 °C) such that rapid evaporation is not expected. These temperature measurements were taken over current densities that range from 100 to 200 A/cm², which are expected in full sized MPD thrusters.

Summary

A number of studies have been recently performed which quantify the benefits of electric propulsion for a very broad set of space missions. These analyses additionally helped define technologies of highest relevance to future missions. The research and technology programs in electrothermal, ion, and electromagnetic propulsion have resulted in significant technical advancements in fundamental understanding and hardware maturity. These advancements, along with the ongoing successful flight applications, should result in increased confidence and payoff in application of electric propulsion.

References

1. Brill, Y., Eisner, A., and Osborn, L., "The Flight Application of a Pulsed Plasma Microthruster, The NOVA Satellite," AIAA Paper 82-1-956, Nov. 1982.
2. Sackheim, R.L., and Howell, G.W., "Trends in Propulsion Systems for Geosynchronous Satellites," Paper presented at the 14th International Symposium on Space Technology and Science, May 28-June 1, 1984, Tokyo, Japan.
3. Pugmire, T.K., Cann, G.L., Heckert, B., and Sovey, J.S., "A 10,000 Hour Life Multipropellant Engine for Space Station Applications," AIAA Paper 86-1403, June 1986.
4. Jones, Robert E., "High- and Low-Thrust Propulsion Systems for the Space Station," AIAA Paper 87-0398, Jan. 1987.
5. Pioneering the Space Frontier, Report of the National Commission on Space, Bantam Books, New York, 1986.
6. Nored, D., and Bernatowicz, D.T., "Electrical Power System Design for the U.S. Space Station," Advancing Toward Technology Breakout in Energy Conversion, Vol. III, American Chemical Society, Columbus, OH, 1986, pp. 1416-1422.
7. Wiley, R.L., Verga, R.L., Sholtis, J.A. Jr., Walquist, E.J., and Schnyer, A.D., "Space Reactor Power 1986: A Year of Choices and Transition," Advancing Toward Technology Breakout in Energy Conversion, Vol. III, American Chemical Society, Columbus, OH, 1986, pp. 1411-1415.
8. Kuriki, K., Kawashima, N., Sasaki, S., Yanagisawa, M., and Obayashi, T., "Space Experiment with Particle Accelerators (SEPAC) Performed in Spacelab First," AIAA Paper 85-1996, Sept. 1985.
9. Kitamura, S., Nagano, H., Nakamura, Y., Kudo, I., and Machida, K., "ETS Ion Engine Flight Operations in the Extended Mission Period," AIAA Paper 85-2010, Sept. 1985.
10. Berry, W., "Status Report on the ESA Sponsored Electric Propulsion Developments," AIAA Paper 85-1997, Sept. 1985.
11. Power, J.L., Ignaczak, L.R., Collett, C.R., and Bever, D.R., "Ion Auxiliary Propulsion System (IAPS) 8-cm Mercury Ion Thruster Flight Test-Status and Supporting Ground Tests," AIAA Paper 85-2025, Oct. 1985.
12. Schreib, Rolland, "Utility of Xenon Ion Station-keeping," AIAA Paper 86-1849, June 1986.
13. Graetch, Joseph E., and Unterberg, Walter, "Fluid Independence of the Space Station," AIAA Paper 86-2309, Sept. 1986.
14. Tacina, R., Personal Communication, NASA Lewis Research Center, Cleveland, OH, July 1986.
15. Heckert, B.J., "Space Station Resistojet System Requirements and Interface Definition Study," RI/RD87-109, Rockwell International Corp., Canoga Park, CA, Feb. 1987. (NASA CR-179581).
16. Palaszewski, Bryan, "Free-Flyer Advanced Propulsion," JPL D-3257, May 1986. (See also Palaszewski, B.A., "Advanced Propulsion for Polar-Orbiting and Co-Orbiting Free Flyers," AIAA Paper 86-1564, June 1986.)
17. Sercel, J., and Krauthamer, S., "Multimegawatt Nuclear Electric Propulsion: First Order System Design and Performance Evaluation," AIAA Paper 86-1202, June 1986.
18. Hardy, T.L., Rawlin, V.K., and Patterson, M.J., "Electric Propulsion Options for the SP-100 Reference Mission," NASA TM-88918, 1987.
19. Mahoney, S.P., and Mekar, M.M., "Nuclear Powered Ion Engine Orbit Transfer Vehicle Design and Operational Effectiveness," AIAA Paper 86-1391, June 1986.

20. Garrison, P.W., and Sigurdson, K.B., "LO₂/LH₂ Propulsion for Outer Planet Orbiter Spacecraft," AIAA Paper 83-1305, June 1983.
21. Whalen, M.V., Grisnik, S.P., and Sovey, J.S., "Compatibility Experiments of Facilities, Materials, and Propellants for Electrothermal Thrusters," 1985 JANNAP Propulsion Meeting, Vol. 1, Edited by K.L. Strange, CPIA-PUBL-425, Chemical Propulsion Information Agency, Laurel, Maryland, 1985, pp. 475-484.
22. Morren, W.E., Whalen, M.V., and Sovey, J.S., "Performance and Endurance Tests of a Multi-propellant Resistojet for Space Station Auxiliary Propulsion," AIAA Paper 86-1435, June 1986.
23. Morren, W.E., and Sovey, J.S., "2000-Hour Endurance Test of a Laboratory Model Multipropellant Resistojet," AIAA Paper 87-0993, May 1987.
24. Zana, L.M., Hoffman, D.J., Beryley, L.R., and Serafini, J.S., "An Analytical and Experimental Investigation of Resistojet Plumes," AIAA Paper 87-0399, Jan. 1987.
25. Gruber, R.P., "Resistojet Control and Power for High Frequency ac Buses," AIAA Paper 87-0994, May 1987.
26. Anderson, B., Private Communication, NASA Lewis Research Center, Cleveland, OH, June 1986.
27. Penko, P.F., Manzella, D.H., DeWitt, K.J., and Keith, T.G., "Effect of Ambient Pressure on the Performance of a Resistojet," AIAA Paper 87-0991, May 1987.
28. Whalen, M.V., Private Communication, NASA Lewis Research Center, Cleveland, OH, Feb. 1987.
29. Smith, W.W., Private Communication, Rocket Research Company, Feb. 1987.
30. Pivrotto, T.J., King, D.Q., and Deininger, W.D., "Long Duration Test of a 30-kW Class Thermal Arcjet Engine," AIAA Paper 87-1083, May 1987.
31. Cassaday, R.J., Britt, E.J., and Meya, R.D., "Performance Testing of a Lightweight 30 kW Arcjet Power Conditioning Unit," AIAA Paper 87-1085, May 1987.
32. Masser, P.S., and Kilgore, O., "Arcjet Analysis and Modeling," AIAA Paper 87-1089, May 1987.
33. Ducati, A.C., Humpal, H., Meltzer, J., Muehlberger, E., Todd, J.P., and Waltzer, H., "1-kW Arcjet-Engine System-Performance Test," Journal of Spacecraft and Rockets, Vol. 1, No. 3, May-June 1964, pp. 327-332.
34. Gruber, R.P., "Power Electronics for a 1-Kilowatt Arcjet Thruster," AIAA Paper 86-1507, June 1986.
35. Curran, F.M., and Haag, T.W., "Arcjet Component Conditions Through a Multistart Test," AIAA Paper 87-1060, May 1987.
36. Haag, T.W., and Curran, F.M., "Arcjet Starting Reliability: A Multistart Test on Hydrogen/Nitrogen Mixtures," AIAA Paper 87-1061, May 1987.
37. Knowles, S.C., Smith, W.W., Curran, F.M., and Haag, T.W., "Performance Characterization of a Low Power Hydrazine Arcjet," AIAA Paper 87-1057, May 1987.
38. Simon, M.A., Knowles, S.C., Curran, F.M., and Hardy, T.L., "Low Power Arcjet Life Issues," AIAA Paper 87-1059, May 1987.
39. Burton, R.L., Fleisher, D., Goldstein, S.A., Tidman, D.A., and Winsor, N.K., "Investigation of a Repetitive Pulsed Electrothermal Thruster," GTD86-5, GT-Devices, Alexandria, VA, Aug. 1986. (NASA CR-179464).
40. Hawley, M.C., Asmussen, J., Filpus, J.W., Whitehair, S., and Chapman, R., "A Review of Research and Development on the Microwave-Plasma Electrothermal Rocket," AIAA Paper 87-1011, May 1987.
41. Brophy, J.R., and Wilbur, P.J., "Simple Performance Model for Ring and Line Cusp Ion Thrusters," AIAA Journal, Vol. 23, No. 11, Nov. 1985, pp. 1731-1736.
42. Brophy, J.R., and Wilbur, P.J., "An Experimental Investigation of Cusped Magnetic Field Discharge Chambers," AIAA Journal, Vol. 24, No. 1, Jan. 1986, pp. 21-26.
43. Wilbur, P.J., and Brophy, J.R., "The Effect of Discharge Chamber Wall Temperature on Ion Thruster Performance," AIAA Journal, Vol. 24, No. 2, Feb. 1986, pp. 278-283.
44. Brophy, J.R., and Wilbur, P.J., "Calculation of Plasma Properties in Ion Sources," AIAA Journal, Vol. 24, No. 9, Sept. 1986, pp. 1519-1523.
45. Rawlin, V.K., Private Communication, NASA Lewis Research Center, Cleveland, OH, Feb. 1987.
46. Beattie, J.R., Matossian, J.N., Poeschel, R.L., Rogers, W. and Martinelli, R., "Xenon Ion Propulsion System," AIAA Paper 85-2012, Sept. 1985.
47. Aston, G., and Brophy, J.R., "Ion Accelerator System Mounting Design and Operating Characteristics for a 5 kW 30-cm Xenon Ion Engine," AIAA Paper 87-1075, May 1987.
48. Garner, C.E., Brophy, J.R., and Biasca, R.J., "The Effects of Gas Mixtures on Ion Engine Erosion and Performance," AIAA Paper 87-1080, May 1987.
49. Aston, G., Brophy, J.R., Garner, C.E., and Pless, L.C., "Operating Characteristics of a 10 kW Xenon Ion Propulsion Module," AIAA Paper 87-1006, May 1987.
50. Choueiri, E.Y., Kelly, A.J., and Jahn, R.G., "Instabilities in the MPD Thruster Plasma," AIAA Paper 87-1067, May 1987.

51. Polk, J.E., Kelly, A.J., and Jahn, R.G., "MPD Thruster Erosion Research," AIAA Paper 87-0999, May 1987.

52. King, D.Q., "Design and Operation of a 100 kW, Subscale MPD Engine," AIAA Paper 87-1020, May 1987.

TABLE 1. - NET MASS AND COST BENEFITS PROVIDED BY XENON ION PROPULSION^a

Power source	Spacecraft stabilization technique			
	Spin		Three axis	
	Batteries and solar	Batteries and solar	Solar only	Batteries and solar
Thrust, mN	35	130	130	130
Net mass benefit, kg	303	218	216	260
New cost benefit, \$M	64	44	41	54

^aRef. 12.

TABLE 2. - CO-ORBITING FREE FLYER SERVICING PROPELLANT REQUIREMENTS, kg^a

Mission	Propulsion technology			
	Hydrazine chemical	Resistojet	Arcjet	Ion
Hubble telescope	1681	1239	614	108
AXAF	682	523	257	45
Micro-gravity, variable-gravity	52	39	19	4
Gamma ray observatory	3704	2894	1475	264

^aRef. 16.

TABLE 3. - COST OF DEPLOYMENT OF GPS GALAXY (28 SATELLITES)

Propulsion system	Deployment cost, \$M
Reusable NEPSa	538
PAM D-II	822
Centaur-G	2491
IUS	3848

^a70 day delivery time.

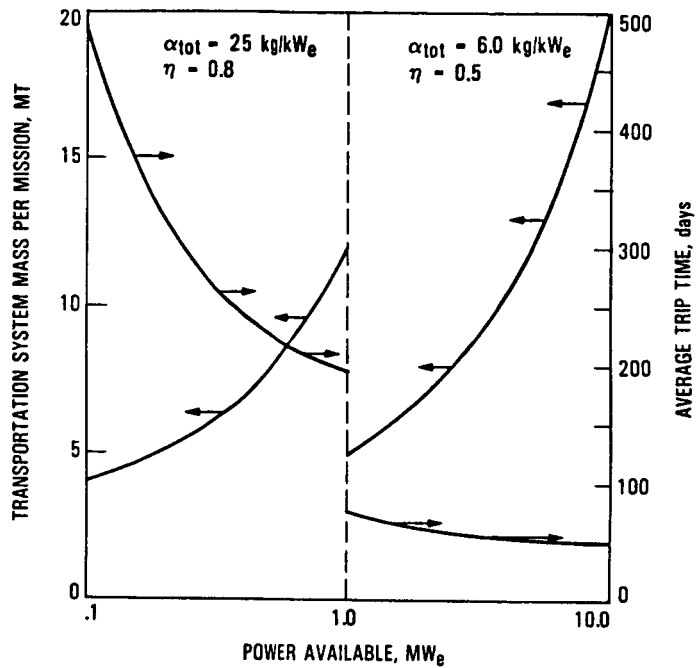

(A) LEO TO GEO.

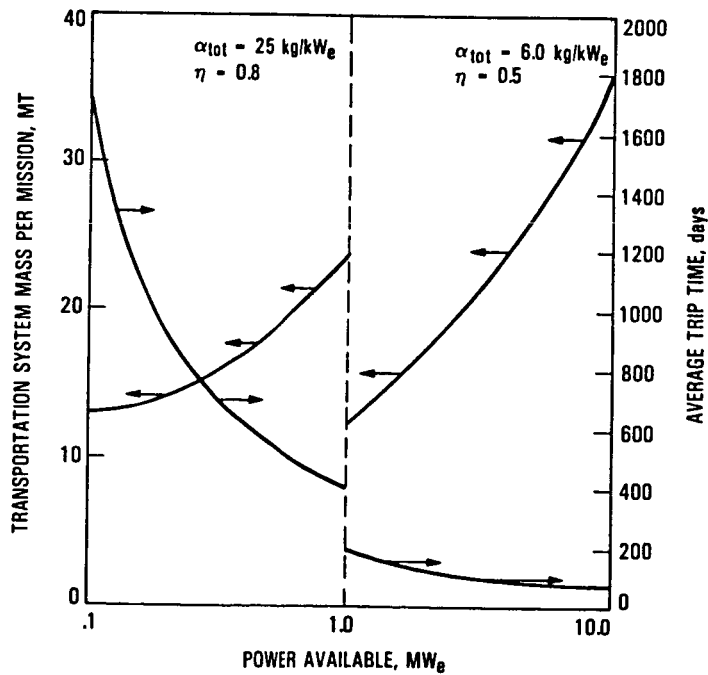

(B) LUNAR BASE.

FIGURE 1. - NEPS MASSES AND TRIP TIMES. (17)

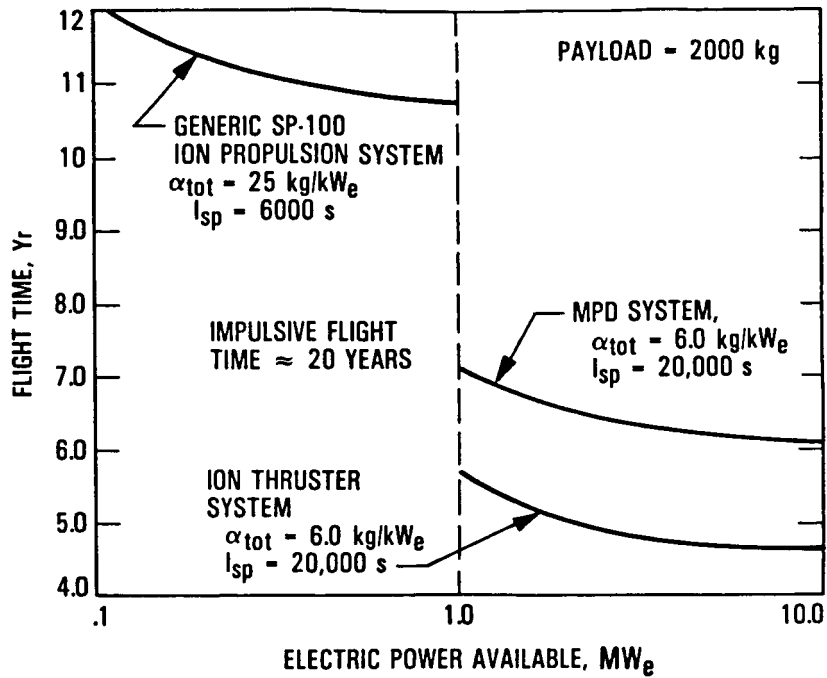
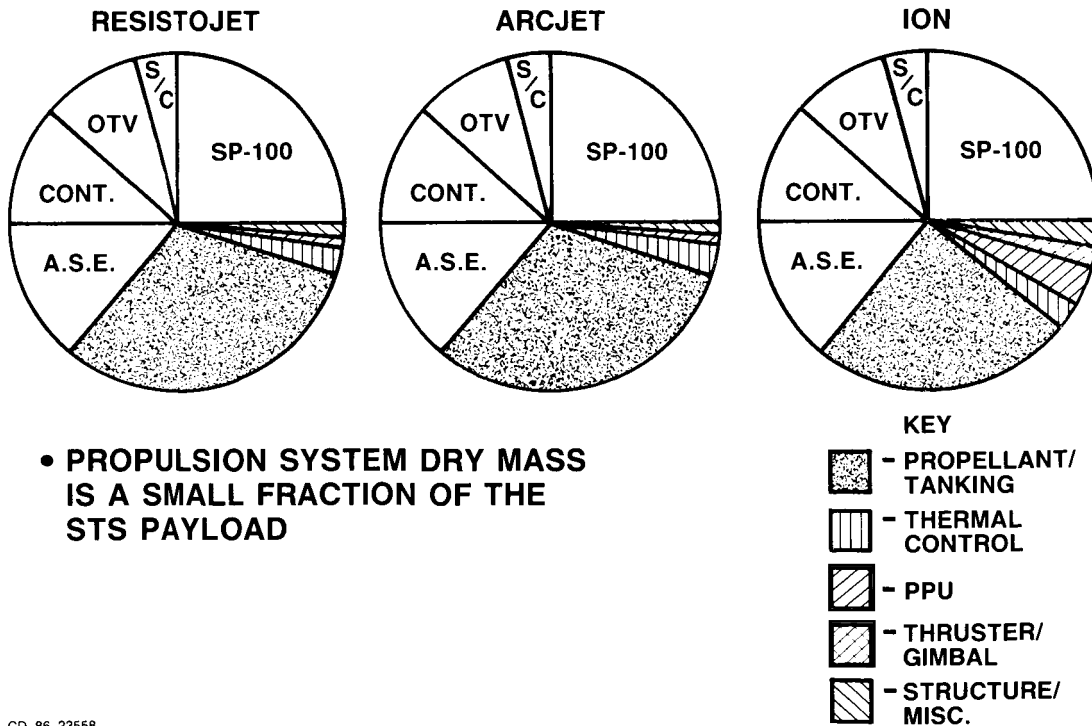

FIGURE 2. - NEPTUNE ORBITER FLIGHT TIMES VERSUS NEPS POWER LEVEL. (17)

300 kW SP-100 REFERENCE MISSION STS MASS DISTRIBUTIONS



CD-86-23558

FIGURE 3. - MASS DISTRIBUTIONS FOR SP-100 REFERENCE MISSION AT 300 kW. (18)

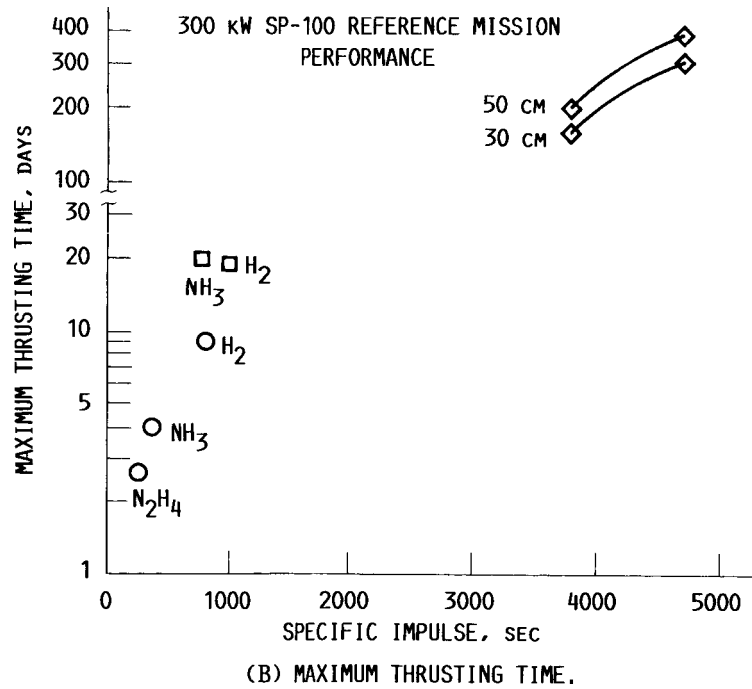
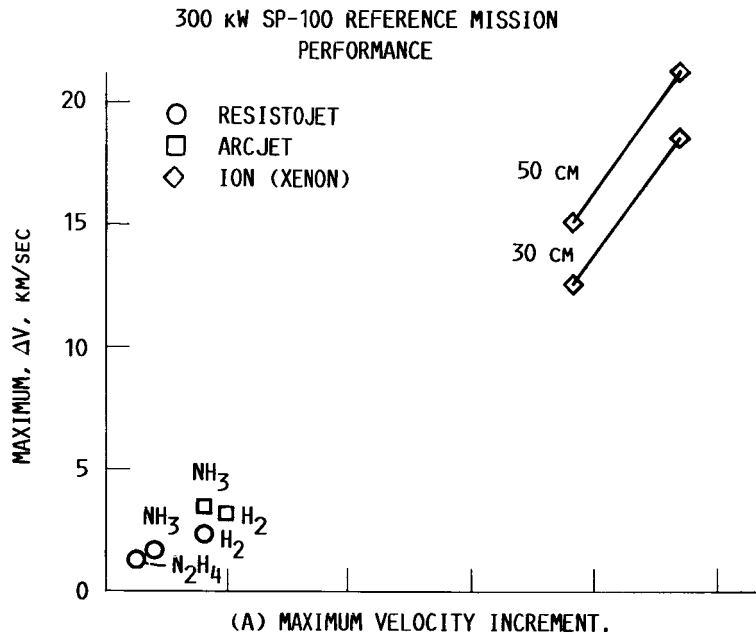
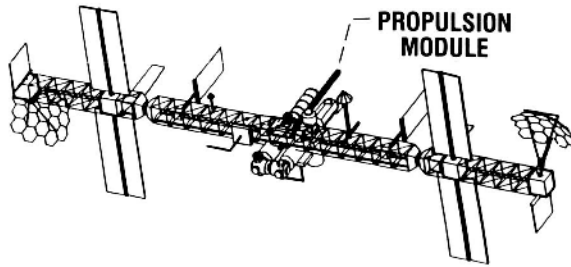
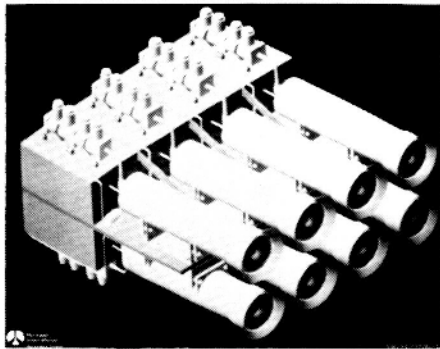

FIGURE 4. - MISSION PERFORMANCES OF 300 kW ELECTRIC PROPULSION SYSTEMS FOR SP-100. (18)

SPACE STATION DRAG MAKEUP USING RESISTOJET



EARLY SPACE STATION



RESISTOJET PROPULSION MODULE

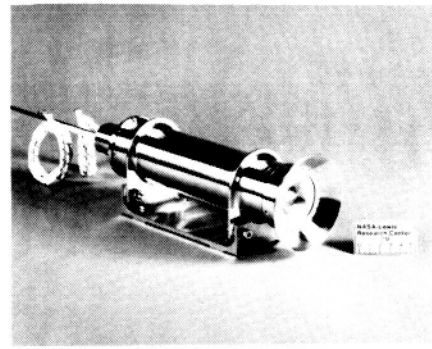

ENGINEERING MODEL RESISTOJET

CD-86-22584

FIGURE 5. - RESISTOJET DRAG MAKEUP MODULE AND THRUSTER. (4)

SPACE STATION RESISTOJET COMPATIBILITY EXPERIMENTS

COMPATIBILITY EXPERIMENTS

- FLOWING GAS ENVIRONMENT
- 1.4 ATM (20 PSIA)

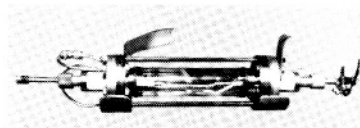

MATERIAL TEST CELL

CANDIDATE PROPELLANTS

TEST DURATIONS, HR	CO ₂	CH ₄	H ₂	NH ₃	N ₂	STEAM	N ₂ H ₄
10		XXX					
100	X	X	XXX	X			
1000	XXX	XX	XX	XX	X	XXX	XX
2000	X		XX	XX			

X = LIFETEST

PLATINUM COMPATIBILITY RESULTS

GAS	HEATER TEMPERATURE, °C	GRAIN STABILIZED PLATINUM LIFE, K-HR
CO ₂	1400	300
CH ₄	500	1500
H ₂	1400	200
N ₂	1400	106
N ₂ H ₄	800	980
STEAM	1400	110

- LIFETIMES EXTRAPOLATED LINEARLY FROM 1000 HOUR TEST RESULTS
- 10% MASS FAILURE CRITERION

- GRAIN STABILIZED PLATINUM COMPONENT LIFE ESTIMATED TO BE IN THE 10 TO 100 YEAR RANGE

FIGURE 6. - RESISTOJET COMPATIBILITY TEST APPROACHES AND RESULTS. (21)

PLUME RESEARCH



COMPARISON OF QCM WITH SIMON'S METHOD

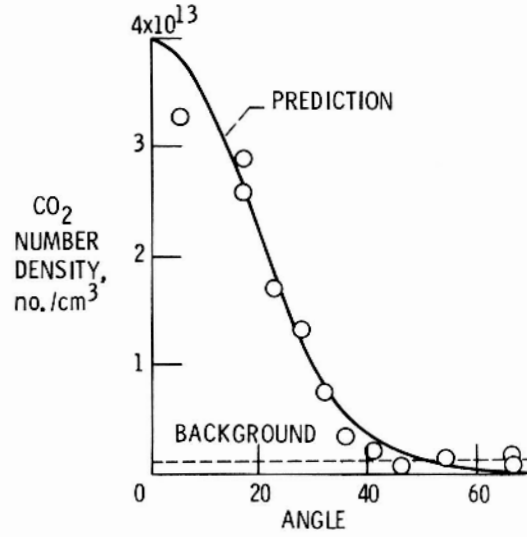

CD-86-19746

FIGURE 7. - RESISTOJET PLUME CHARACTERIZATIONS. (24)

$(A_{EXIT}/A_{THROAT} = 100.0, REY = 1000.0)$

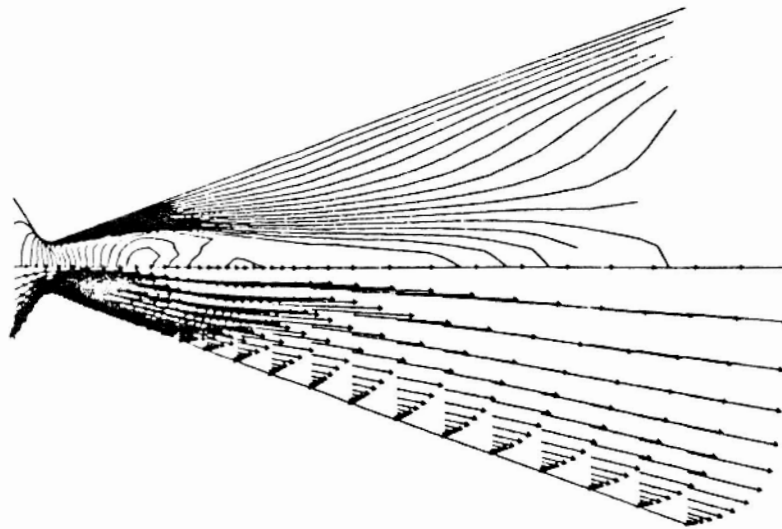

FIGURE 8. - MACH NUMBER AND STREAMLINE VELOCITY VECTORS.

RELIABLE, NON - DAMAGING ARCJET STARTING

- START - UP DAMAGE ELIMINATED VIA OPTIMIZATION:

— FLOW FIELDS — POWER CIRCUITS — GEOMETRY

NON - OPTIMIZED

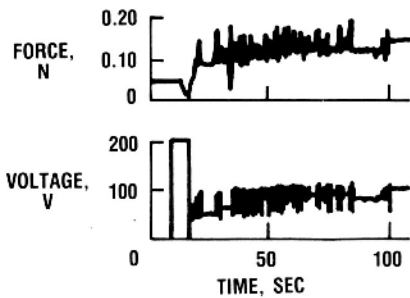
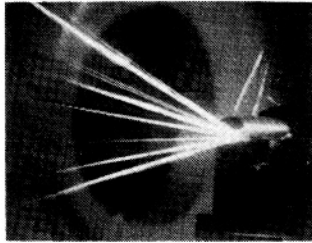

OPTIMIZED

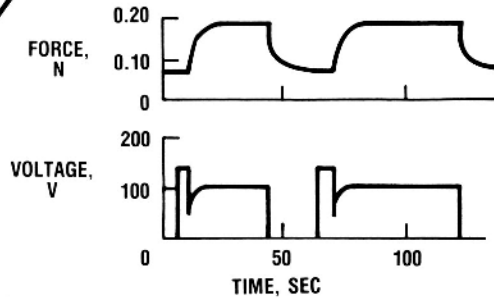
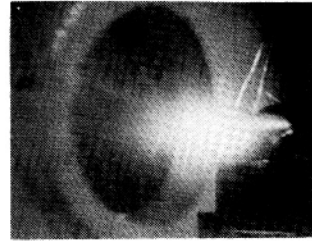

- RELIABLE START-UP ENABLES LONG-LIFE MULTI-START OPERATION

CD-86-22585

FIGURE 9. - ARCJET STARTING PHENOMENA. (35)

CATHODE MATERIALS TESTING

- THORIATED TUNGSTEN CATHODES
- NEARLY IDENTICAL OPERATING CONDITIONS
- INCREASING VORTEX STRENGTH DECREASES CATHODE DAMAGE

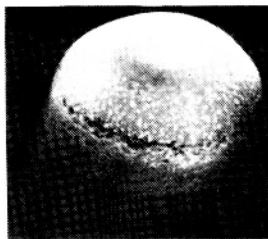

• 30X
• 8 Hrs

$S=0.063$

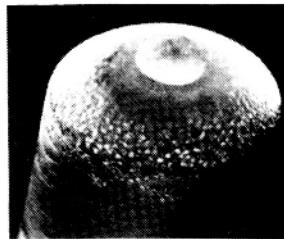

• 30X
• 8 Hrs

$S=0.072$

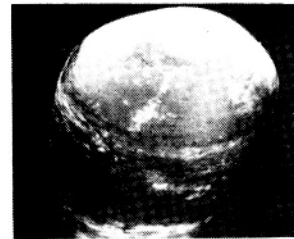

• 30X
• 6.5 Hrs

$S=0.089$

FIGURE 10. - CATHODE DAMAGE AS A FUNCTION OF VORTEX STRENGTH. (36)

ARCJET PERFORMANCE TESTING

- I_{SP} APPROXIMATELY SPECIFIED BY P/\dot{m} OVER RANGE OF GEOMETRIES TESTED
- I_{SP} VALUES FROM 400 TO 730 SECONDS ACHIEVED ON HYDRAZINE
- NO FUNDAMENTAL LIMIT OBSERVED; HIGHER SPECIFIC IMPULSE VALUES POSSIBLE

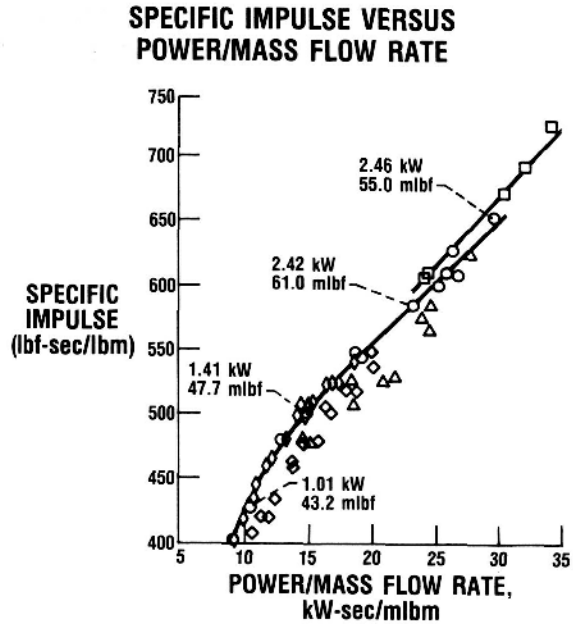
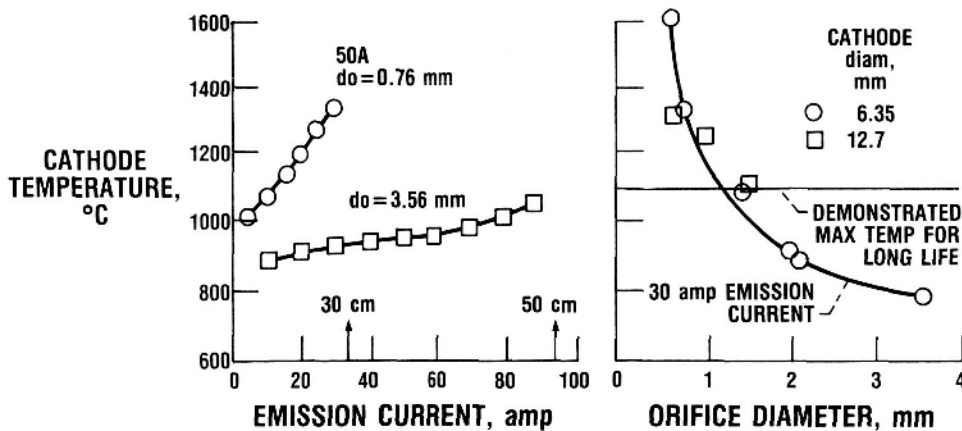

FIGURE 11. - HYDRAZINE ARCJET PERFORMANCE VERSUS POWER TO MASS FLOW RATIO. (37)

LOW TEMPERATURE, HIGH CURRENT HOLLOW CATHODE

- HIGH CURRENT CATHODE FAILURE ELIMINATED VIA REDESIGN:
 - ORIFICE DIAMETER
 - RADIATING FIN
 - UNDERSTANDING OF OPERATION



CD-86-22814

FIGURE 12. - HOLLOW CATHODE TEMPERATURE VERSUS CURRENT AND ORIFICE DIAMETER. (45)

ORIGINAL PAGE IS
OF POOR QUALITY

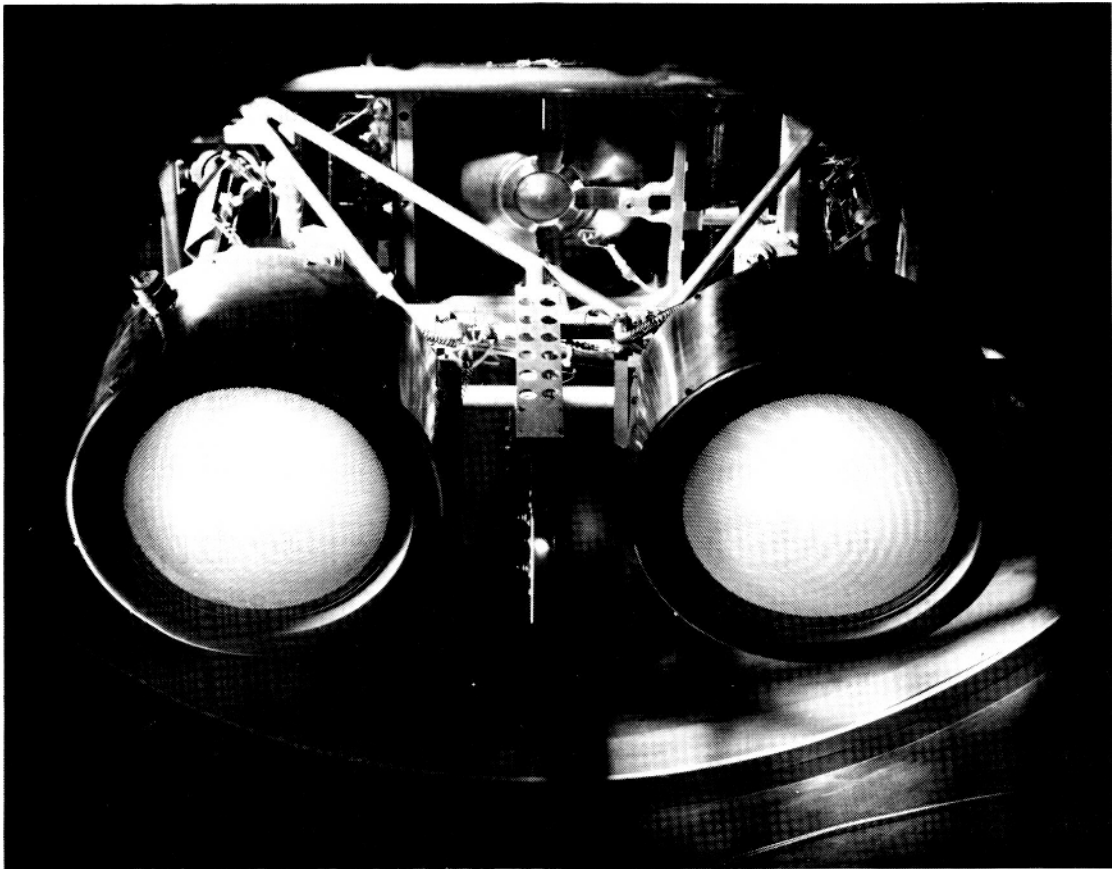

FIGURE 13. - 10 kW XENON ION PROPULSION MODULE. (49)

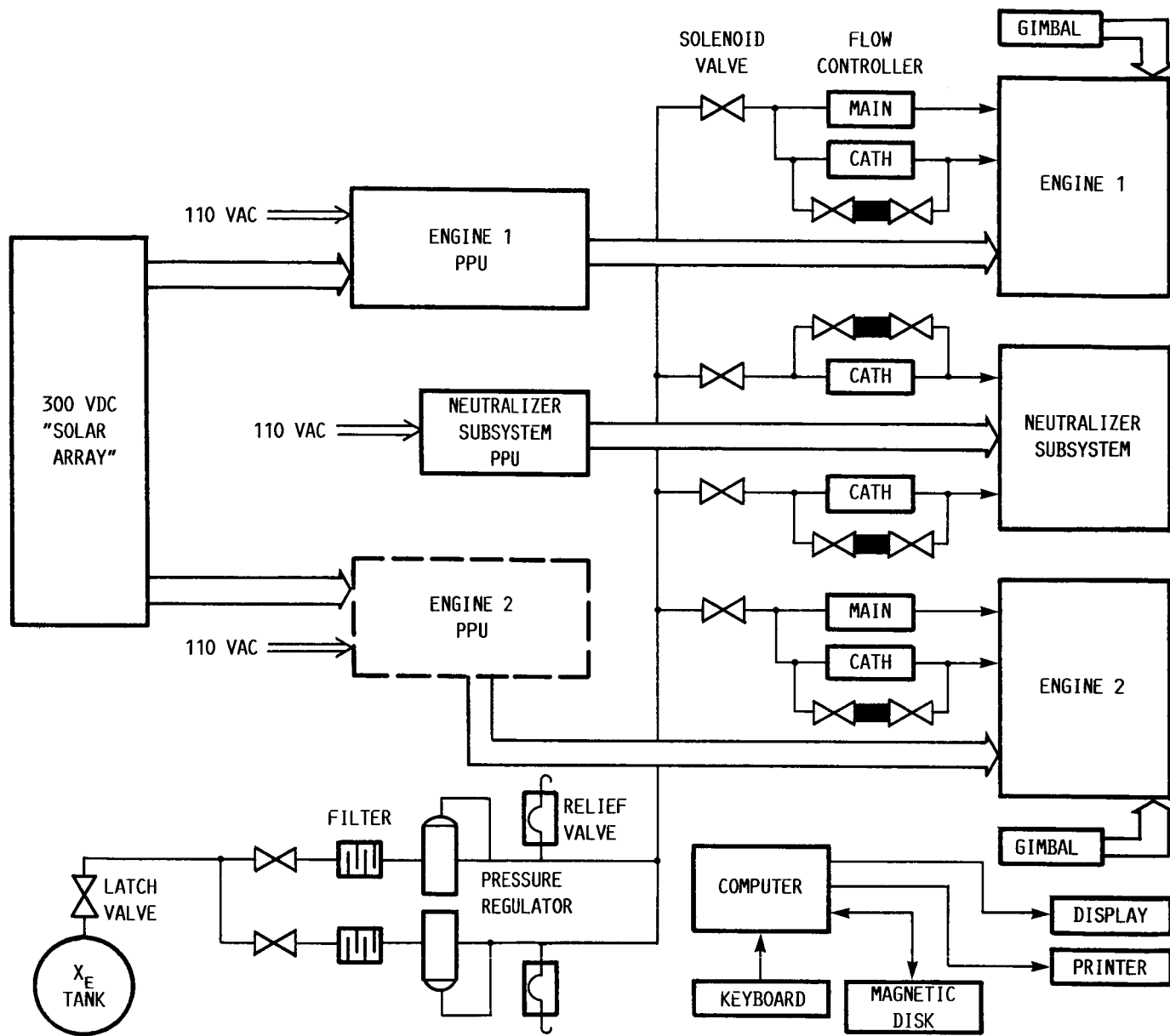

FIGURE 14. - 10 kW XENON ION PROPULSION MODULE CONTROL SYSTEM. (49)

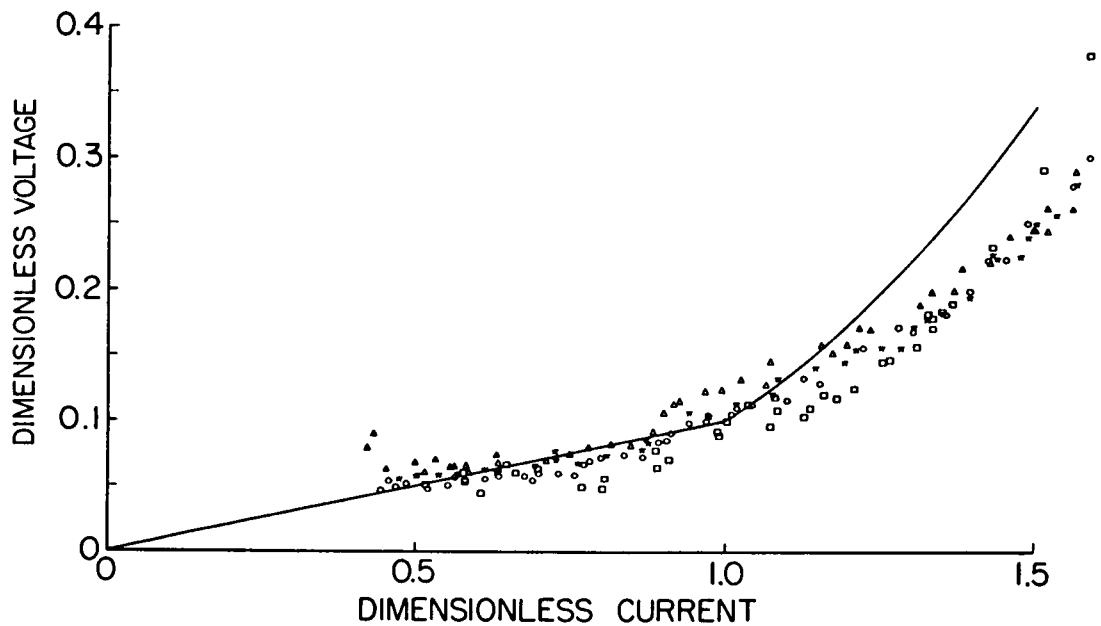

FIGURE 15. - COMPARISON OF MPD ARC MODEL WITH DATA. (50)

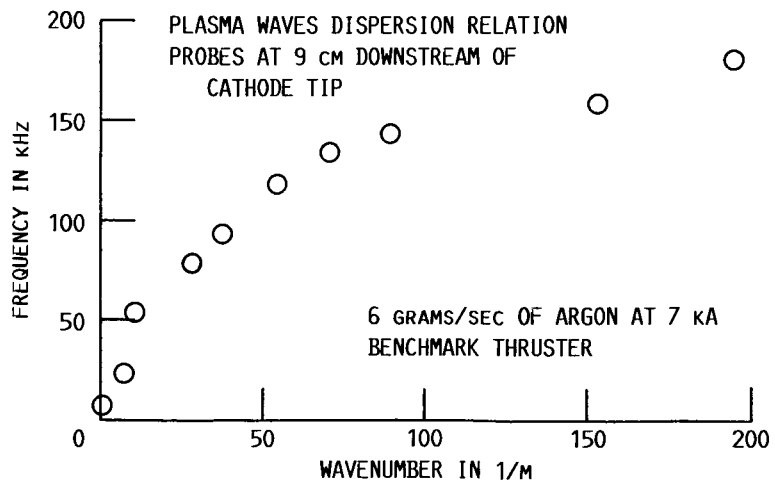

FIGURE 16. - PLASMA WAVE DISPERSION RELATIONSHIP WITH BENCHMARK MPD. (50)

ORIGINAL PAGE IS
OF POOR QUALITY

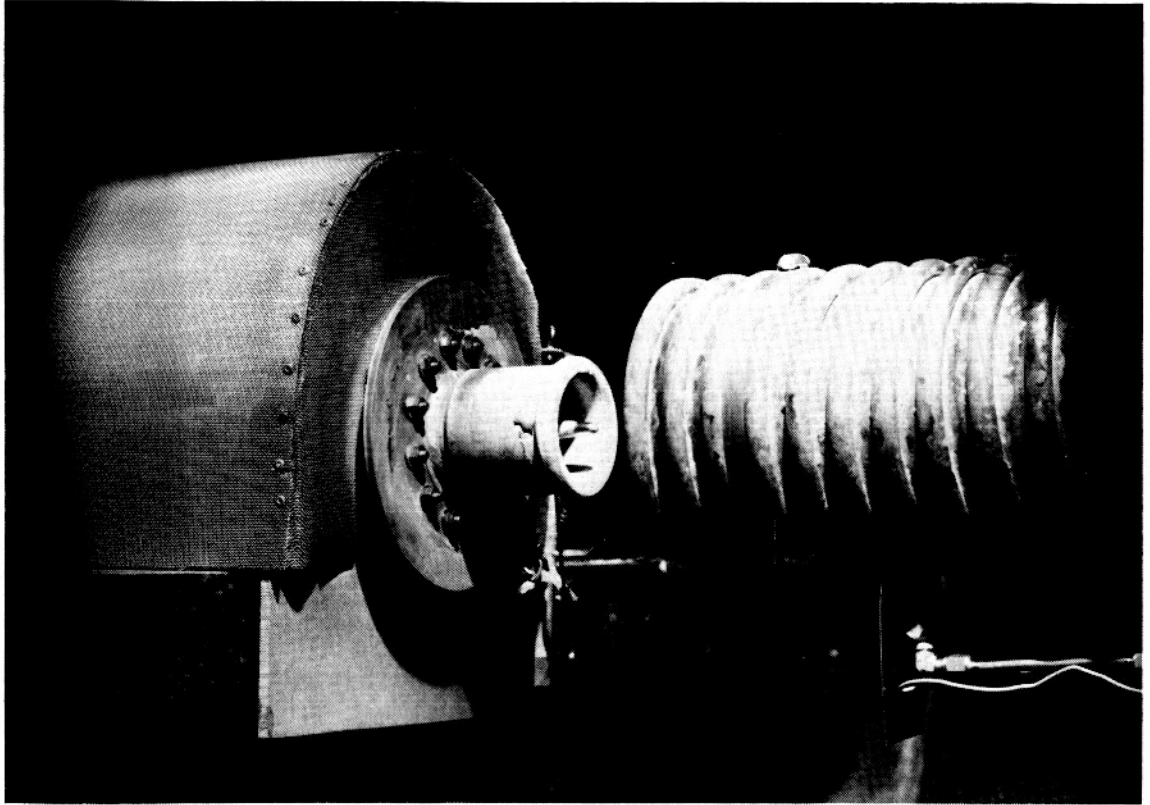

FIGURE 17. - 100 kW SUBSCALE MPD THRUSTER.

1. Report No. NASA TM-89856 AIAA-87-1098		2. Government Accession No.		3. Recipient's Catalog No.	
4. Title and Subtitle The NASA Electric Propulsion Program				5. Report Date	
				6. Performing Organization Code 506-42-31	
7. Author(s) David C. Byers and Robert A. Wasel				8. Performing Organization Report No. E-3524	
				10. Work Unit No.	
9. Performing Organization Name and Address National Aeronautics and Space Administration Lewis Research Center Cleveland, Ohio 44135				11. Contract or Grant No.	
				13. Type of Report and Period Covered Technical Memorandum	
12. Sponsoring Agency Name and Address National Aeronautics and Space Administration Washington, D.C. 20546				14. Sponsoring Agency Code	
15. Supplementary Notes Prepared for the 19th International Electric Propulsion Conference cosponsored by the AIAA, DGLR, and JSASS, Colorado Springs, Colorado, May 11-13, 1987. David C. Byers, NASA Lewis Research Center; Robert A. Wasel, NASA Headquarters, Office of Aeronautics and Space Technology, Washington, D.C. 20546.					
16. Abstract The NASA OAST Propulsion, Power, and Energy Division supports electric propulsion for a broad class of missions. Concepts with potential to significantly benefit or enable space exploration and exploitation are identified and advanced toward applications in the near to far term. This paper summarizes recent program progress in mission/system analyses and in electrothermal, ion, and electromagnetic technologies.					
17. Key Words (Suggested by Author(s)) Electric propulsion Arcjets Ion thrusters			18. Distribution Statement Unclassified - unlimited STAR Category 20		
19. Security Classif. (of this report) Unclassified		20. Security Classif. (of this page) Unclassified		21. No. of pages 20	22. Price* A02