

NASA Technical Memorandum 4703

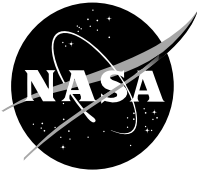

# **The NASA Landing Gear Test Airplane**

*John F. Carter and Christopher J. Nagy*

June 1995

# **The NASA Landing Gear Test Airplane**

*John F. Carter  
NASA Dryden Flight Research Center  
Edwards, CA*

*Christopher J. Nagy  
PRC Inc.  
Edwards, CA*

## ABSTRACT

A tire and landing gear test facility has been developed and incorporated into a Convair 990 aircraft. The system can simulate tire vertical load profiles to 250,000 lb, sideslip angles to 15 degrees, and wheel braking on actual runways. Onboard computers control the preprogrammed test profiles through a feedback loop and also record three axis loads, tire slip angle, and tire condition. The aircraft to date has provided tire force and wear data for the Shuttle Orbiter tire on three different runways and at east and west coast landing sites.

This report discusses the role of this facility in complementing existing ground tire and landing gear test facilities, and how this facility can simultaneously simulate the vertical load, tire slip, velocity, and surface for an entire aircraft landing. A description is given of the aircraft as well as the test system. An example of a typical test sequence is presented. Data collection and reduction from this facility are discussed, as well as accuracies of calculated parameters. Validation of the facility through ground and flight test is presented.

Tests to date have shown that this facility can operate at remote sites and gather complete data sets of load, slip, and velocity on actual runway surfaces. The ground and flight tests have led to a successful validation of this test facility.

## NOMENCLATURE

deg	degrees
DFRC	Dryden Flight Research Center, Edwards, California
Hz	Hertz
KGS	knots ground speed
KIAS	knots indicated airspeed
KSC	John F. Kennedy Space Center, Florida
LSRA	Landing Systems Research Aircraft
n mi	nautical miles
psi	pounds per square inch
STS	Space Transportation System

## INTRODUCTION

Tire and landing gear development and testing for aircraft are usually done by ground test facilities due to the expense and hazards associated with testing on aircraft.

Tire dynamometer and sled tire track are the two facilities used mainly for dynamic tire testing. Existing facilities have limitations in simulating the landing surface, time varying vertical loads, and tire slip angles.

Tire dynamometer facilities roll aircraft tires against a metal drum at any combination of velocity, vertical load, and slip angle. These facilities have the advantage of long run times, very good load and speed control, and good control of the slip angle of the tire. However, dynamometers have disadvantages for dynamic tire testing, such as

- 1) the dynamometer rotary drum surface does not accurately simulate a runway surface,
- 2) the curvature of the contact area of the drum causes incorrect radial tire deflection during the test, and
- 3) heat build up of the drum causes the temperature of the test tire to be abnormally high.

Because of these problems, dynamometer data are used primarily to measure the strength and endurance of tire carcass material, not the tire surface forces or wear. Appendix A shows a tire dynamometer at Wright Patterson Air Force Base in Dayton, Ohio. An example of data obtained from this type of dynamometer is given in reference 1.

Tire sled-type facilities mount the tire on a carriage and move the carriage down a straight path.<sup>2</sup> A test surface can be constructed which simulates an aircraft runway, but the process can be time consuming and may not accurately represent the surface. Existing facilities also have problems due to their limited run times, limited capability for time varying vertical load, speed, and tire slip angle control. Because of limited track length, simulations of complete aircraft landings typically are completed in segments, with a single landing test requiring as many as five test runs. In addition to the inconvenience of multiple runs, cooling of the test tire between runs can cause inaccurate results.

The unique design of the Space Shuttle Orbiter landing gear with its highly loaded tires, hazards associated with tire failure, as well as limited opportunities for landing test data from the vehicle resulted in a strong reliance on tire test facilities. Because of high landing speeds, high vertical loads, long roll out distances, and unusually rough runway surfaces, existing tire test facilities have had difficulties in accurately simulating the tire wear and forces of an entire shuttle landing.

The Landing Systems Research Aircraft (LSRA) is a unique addition to complement existing aircraft dynamic tire testing facilities. Its capabilities are compatible with the Space Shuttle Orbiter requirements. The design goal of the LSRA is to conduct dynamic tire testing on an actual surface while simulating vertical loading, tire slip angle, and speed of an entire aircraft landing simultaneously. Computer control of a tire test fixture allows for precise control of vertical load and slip angle of the test tire. The computer control software also provides a speed advisory to the pilot. These capabilities make it possible for the LSRA to recreate a realistic combination of run distance, runway surface, vertical load, tire slip angle, and ground velocity for aircraft landings.

The LSRA is the result of a cooperative effort of the Dryden Flight Research Center (DFRC), Lyndon B. Johnson Space Center (JSC), John F. Kennedy Space Center (KSC), Langley Research Center (LaRC), Ames Research Center (ARC), and many industry and military organizations. Flight test has been conducted on runways at Edwards Air Force Base and KSC.

This paper describes the systems and capabilities of the LSRA vehicle. In addition, this paper discusses ground calibration and flight tests used to validate the LSRA as a test facility.

## AIRCRAFT DESCRIPTION

The NASA Convair 990 (SN 10-29, tail No. 810) is a high-speed, medium range, low-swept-wing jet transport (fig. 1). This aircraft is equipped with four wing-pylon mounted General Electric® CJ805-23 aft fan turbojet engines and a fully retractable tricycle landing gear (the main gear can no longer be retracted with the LSRA modification). The aircraft is controlled by dual wheel and columns located in the cockpit. The control surfaces are moved using a combination of mechanically driven flight tabs and hydraulics. The basic control system is augmented with a yaw damper which drives the rudder.

The LSRA underwent significant structural modification to provide space for the test gear and also to react the test gear loads into the aircraft. Normal aircraft structural factors of safety were maintained for all the original structural design conditions plus the additional loading conditions for landing gear testing as defined in this report.

The primary components of the landing gear test system added to the LSRA are shown in figures 2 and 3. Figure 2 identifies the test pallet system elements within the aircraft. The hydraulic power of the gear test pallet is provided by accumulators which use compressed nitrogen gas. Onboard hydraulic pumps are used to pressurize the accumulators. The test pallet system is controlled by a test conductor console which contains hardware switching capability and system monitoring capability. Included in the system is a computer which controls the motion of the test gear pallet. In addition to the vertical load, the test pallet system can apply braking to the test tire. Aircraft performance specifications before and after the LSRA modification are presented in table 1.

Figure 3 shows the pallet which is the interface point between the test fixture and the landing gear test system. The pallet is attached to the aircraft through a pair of parallelogram swing links which restrain the test gear in pitch, roll, and yaw. The top of the test pallet is attached to two hydraulic actuators which provide the vertical reaction load. The vertical loads are reacted into the airframe through a truss system located inside the cabin.

®The CJ805-23 engine is a registered trademark of General Electric, Lynn, MA.

Table 1. Aircraft operational limits before and after LSRA modifications.

	Original CV990 Aircraft	LSRA
Max. taxi weight, lb	255,000	250,000
Max. takeoff weight, lb	245,000	245,000
Max. landing weight, lb	202,000	225,000
Max. landing speed, kgs	195	230
Max. range, n mi	3000	600
Max. ceiling, ft	41,000	13,000
Max. velocity, KIAS	520	250
Empty weight, lb	115,000	177,000

NOTE: data taken from operations manuals of the CV990/LSRA.

## SYSTEM CAPABILITIES

Many landing gear test fixtures can be attached to the LSRA test pallet. Currently two attachments have been designed. One is a modified shuttle main landing gear strut with dual tires, the other is a single tire fixture that contains a rotary actuator which can be turned for desired slip angle. Table 2 presents the maximum load and steering capability of the LSRA for these two fixtures.

Figure 4 shows a model of the single tire fixture. The fixture frame is attached to the test pallet. This frame houses the rotary actuator which turns the test tire axle assembly. Tire braking is applied through the braking assembly. This test fixture was used exclusively for all the testing described in this report.

A test computer controls the test tire vertical load and slip angle using feedback loops, and sends a discrete signal to activate the wheel brake. Table 3 shows the capabilities of the control system. During a test, the computer also displays to the pilot the difference between the current measured ground speed and the desired speed profile for the test. The test tire vertical load feedback is provided directly from vertical

Table 2. Structural load capabilities of the LSRA.

	Main gear dual tire	Variable yaw fixture single tire
Vertical load, lb	250,000, -50,000	150,000, -25,000
Drag load at tire contact point, lb	$\pm 100,000$	$\pm 50,000$
Side load at tire contact point, lb	$\pm 40,000$	$\pm 40,000$
Brake torque, in-lb	N/A	+ 800,000 - 250,000
Steering torque, in-lb	N/A	380,000

Table 3. Performance of the LSRA test system with the single rotational tire fixture.

Load control system max rate, unloaded	15 in/sec
Load control system max rate, max load	7 in/sec
Steering control system max rate	35 deg/sec
Maximum steering angle	$\pm 20$ deg
Load control system bandwidth	2 Hz
Steering control system bandwidth	3 Hz
Maximum error from commanded profile, load	$\pm 3000$ lb
Maximum error from commanded profile, slip	.25 deg
Typical error from commanded profile, speed	$\pm 10$ kts

load cell measurements while the slip angle is computed, as seen in figure 5, from a combination of an angular displacement sensor on the steering fixture and two optical ground velocity sensors which provide aircraft slip angle across the runway.

## **SAFETY SYSTEMS**

The test pallet system includes a fail-safe feature which retracts the test pallet to its stowed position. Pallet retraction can be caused by fault detection in hardware or software. The gear control system fault detection software performs comparisons between redundant input signals, compares input signals to minimum and maximum output values, and compares steering and extension values to simulated predictions. Hardware fault switches detect over extension, ground contact, and over rotation of the test pallet. If the test pallet cannot be retracted due to a mechanical failure, the hydraulic actuators can be separated from the test pallet by explosive bolts. The tire retraction and the actuator separation can be performed manually by either the test conductor or the pilot.

In addition to the test pallet retraction system, there are two fire suppression systems associated with the test pallet system. A water deluge system was installed which can spray water directly on the CV990 main landing gear tires, brakes, and the test tire. A halon fire suppression system was placed in the cargo bay near the hydraulic pumps to extinguish any fires in that area.

## **TEST OPERATIONS**

Flight planning and data analysis are performed with the aid of a six-degree-of-freedom simulation resident on a desktop workstation. This simulation was programmed using the FORTRAN® computer language and executes at 100 Hz, with a 400-Hz execution for landing gear dynamics. Aerodynamic data used in the simulation were obtained from wind tunnel models, and then refined using data obtained during early NASA flight test of the CV990. The workstation is interfaced with a gear control computer which is a duplicate of the aircraft gear control computer. This configuration allows for production and hardware-in-the-loop simulation testing of new time history profiles, as well as verification and validation of flight software revisions. The workstation and duplicate aircraft gear control computer configuration were designed to be portable so that simulation, analysis, verification, and validation functions would be retained at remote testing sites.

The time history profiles of load, slip, and speed are produced using output from this simulation, and then converted to a binary format which is loaded onto a data diskette. After testing the profiles on this disk using the hardware-in-the-loop configuration, this data diskette is then used to load the profiles onto the aircraft gear control computer. A new time history profile can be developed in approximately one hour. A new gear control software version can be qualified for flight in approximately three hours.

Figure 6 shows a typical landing test sequence. The CV990 aircraft makes a final approach. After touchdown and derotation, the pilot calls for test initiation and uses spoilers, thrust reversers, and brakes to follow the pilot speed advisory. The test gear is extended and controlled to match the preprogrammed test profiles of vertical load, slip angle, and braking on the test tire. Upon completion of the test, the test gear is automatically retracted. If a problem occurs during the test, either the computer or the hardware fault detection system will command a retraction of the test gear. If a retraction does not occur, the test

---

®FORTRAN is a registered trademark of Information Processing Techniques Corp., Palo Alto, CA.

conductor or pilot can unload the test fixture by exploding the bolts connecting the test gear assembly to the hydraulic actuators, thus relieving the vertical load to the test gear assembly.

The LSRA has performed approximately 100 test operations at Edwards AFB and KSC. During these operations, all flight test profile preparation, data reduction, and analysis were performed at the test site.

## **DATA REDUCTION**

The LSRA can collect onboard data or telemetered data. The data rates for the parameters range from 25 to 200 Hz. The test pallet has been instrumented with load cells in three axes. Appendix B presents the equations for calculations and corrections for vertical, side, and drag loads. Accuracies of the measured loads for the Shuttle Orbiter tire tests are  $\pm 3000$  lb vertical load,  $\pm 500$  lb side load, and  $\pm 300$  lb drag load.

In addition to the onboard and telemetered data, the LSRA has video cameras which can provide five different views of the tire fixture. These cameras allow for real-time monitoring of tests, as well as post flight analysis using video tape which is synchronized with the other data. High-speed film of tests is also available.

## **TEST VALIDATION / FLIGHT TEST RESULTS**

Calibration of the LSRA load cells was performed at DFRC. This was done by attaching static test equipment to the test pallet and loading it to known values of vertical, side, and drag loads. This calibration effort provided information to validate the LSRA gear control software calibrations, provided information on elastic deformation of the test fixture, and verified post flight data measurements.

The LSRA has performed two validation landing simulations; one was performed at the Edwards AFB concrete runway, the other at KSC. The purpose of these tests was to validate the LSRA as a tire testing facility by simulating an actual Space Shuttle Orbiter landing and comparing the test tire wear from the LSRA to the tire wear of the Space Shuttle Orbiter. While both tests were successful, only the KSC test will be discussed in detail to illustrate the process. The Space Shuttle Orbiter landing chosen for the comparison was the STS 51-D landing. On this landing, the Space Shuttle Orbiter landed on Runway 33 with approximately 8 knots of crosswind from the right-hand side of the vehicle. The weight of the Space Shuttle Orbiter was approximately 200,000 lb. Inertial platform data as well as strain gage data recorded from this landing were used to derive the load, slip, and speed profiles for the left inboard main gear tire of the Space Shuttle Orbiter. The local tilt angle of this tire during the Orbiter landing was simulated by raising the right-hand strut of the LSRA until the test tire tilt angle was approximately  $-1.6$  deg (left wing down).

The LSRA performed the profile shown in figure 7 on Runway 33. A load "spike" was placed at the beginning of the load time history profile to create the initial load of 70,000 lb to simulate initial tire touchdown. After the initial load, the average load control for the time history stayed within  $\pm 3000$  lb of the target value. The slip controller held the slip angle to within approximately .40 deg until the speed fell below 50 knots, at which point the resolution of the optical sensors caused some steering oscillations. The steering system exhibited an oscillation of approximately .2 deg at 2 Hz. Subsequent slip controller improvements have eliminated these two anomalies. Figure 8 shows a time history of the achieved slip angle plotted against the commanded slip angle after the improvements were made. The steering system



currently holds the slip angle to within .25 deg of commanded slip angle throughout the speed range. The roll out of this test was estimated to be 10,300 ft, and the roll out of the Space Shuttle Orbiter test was 10,000 ft. The outside air temperatures were approximately the same between the LSRA test and STS 51-D landing. Figure 9 compares the LSRA test tire with the STS 51-D Space Shuttle Orbiter tire. For both tires, three cords were exposed on the left-most rib, and most of the other ribs were worn off. This near identical tire wear was a significant factor in the validation of the LSRA as an Space Shuttle Orbiter tire test bed.

The LSRA effort has provided significant data to the Space Shuttle program. Tests on the Edwards Air Force Base dry lakebed runways were used to redefine the tire drag model used in Space Shuttle Orbiter simulations and flight planning. A 20-knot crosswind capability was demonstrated for Space Shuttle Orbiter landings on the Edwards Air Force Base concrete runway, and LSRA testing helped define the effects of ply steer and wheel tilt on the Space Shuttle Orbiter tire force model. The most significant contribution of the LSRA to the Space Shuttle Orbiter program is the tire wear data that contributed to defining the need for the KSC shuttle landing facility runway resurfacing.

## **CONCLUDING REMARKS**

The Landing Systems Research Aircraft (LSRA) provides a unique test bed for landing gear testing which can reproduce vertical load, speed, slip angle, and actual runway surface.

Validation of the LSRA concept was achieved by recreating tire wear from actual Space Shuttle Orbiter landings based on profiles from Space Shuttle Orbiter data. Static load calibration tests have verified the flight measurements of the LSRA. Flight testing has shown the LSRA to be an efficient test facility at remote sites.

The LSRA has had a significant impact on the Space Shuttle Orbiter program. Tire force and wear data from the LSRA were instrumental in upgrading tire force and wear models used by the Space Shuttle Orbiter program. LSRA data helped to define the resurfacing requirements for the smoothing of the KSC runway surface.

The testing on the LSRA is complementary to the existing national dynamometer and test track facilities. By comparing and cross checking tire force and wear data under actual landing conditions, this facility can validate results from other tire testing facilities.

Flight test of the system showed that the vertical load time history profile can be tracked within  $\pm 3000$  lb, and the tire slip profile can be tracked within  $\pm .25$  deg. This performance was considered acceptable for this application.

Features such as a generic test pallet that can have many different test fixtures attached to it, and the ability to change commanded time history profiles of the load, slip, and speed have ensured that the LSRA is a useful tool as a generic test bed.

## REFERENCES

1. Beall, Leman G., *Dynamometer Evaluation of Continuous Tape Wound Type III Aircraft tires*, Technical Report AFFDL-TR-69-102, Dec. 1969.
2. Davis, Pamela A., Sandy M. Stubbs, and John A. Tanner, *Aircraft Landing Dynamics Facility, A Unique Facility With New Capabilities*. SAE Tech Paper Ser. 851938, Oct. 1985.

## BIBLIOGRAPHY

Beall, Leman G.: *Dynamometer Evaluation of Continuous Tape Wound Type III Aircraft tires*, Technical Report AFFDL-TR-69-102, Dec. 1969.

Davis, Pamela A., Sandy M. Stubbs, and John A. Tanner, *Aircraft Landing Dynamics Facility, A Unique Facility With New Capabilities*, SAE Tech Paper Ser. 851938, Oct. 1985.

Daugherty, Robert F., Sandy M. Stubbs, and Martha P. Robinson, *Cornering Characteristics of the Main-Gear Tire of the Space Shuttle Orbiter*, NASA TP-2790, 1988.

Leland, Trafford J. W., Thomas J. Yager, and Upshur T. Joyner, *Effects of Pavement texture on Wet-Runway Braking Performance*, NASA TN D-4323, 1968.

Tanner, John A., Sandy M. Stubbs, and John L. McCarty, *Static and Yawed-Rolling Mechanical Properties of two types VIII Aircraft Tires*, NASA TP-1863, 1981.

Vogler, William A., and John A. Tanner, *Cornering Characteristics of the Nose-Gear Tire of the Space Shuttle Orbiter*, NASA TP-1917, 1981.

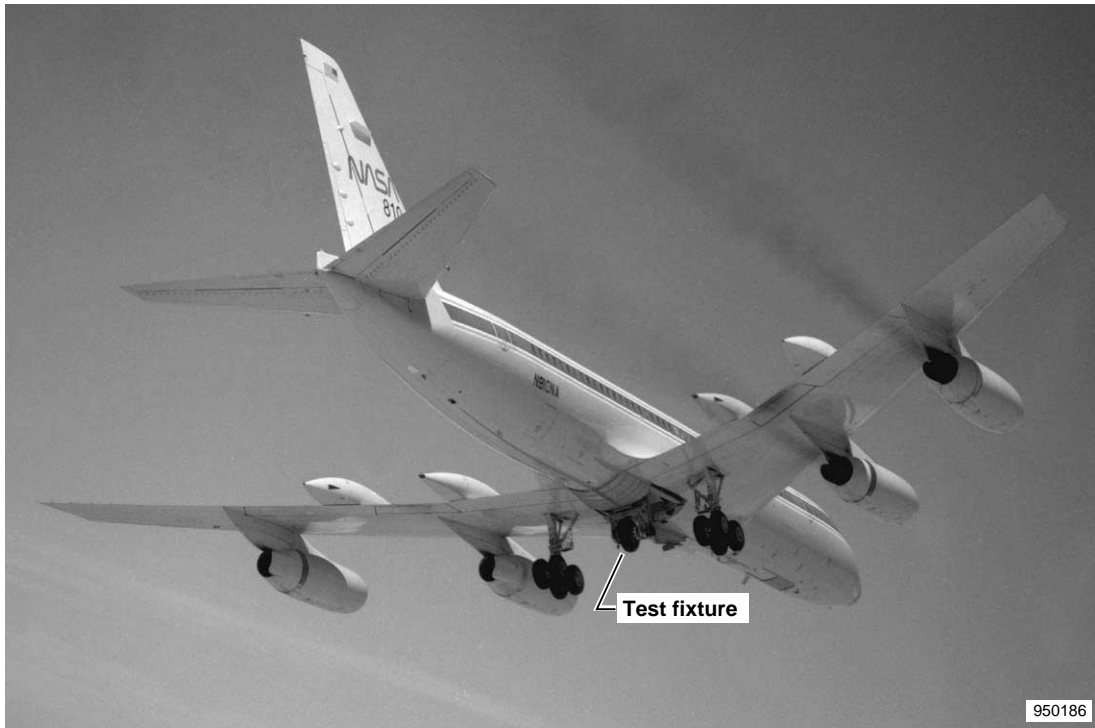

Figure 1. Convair 990 with test fixture.

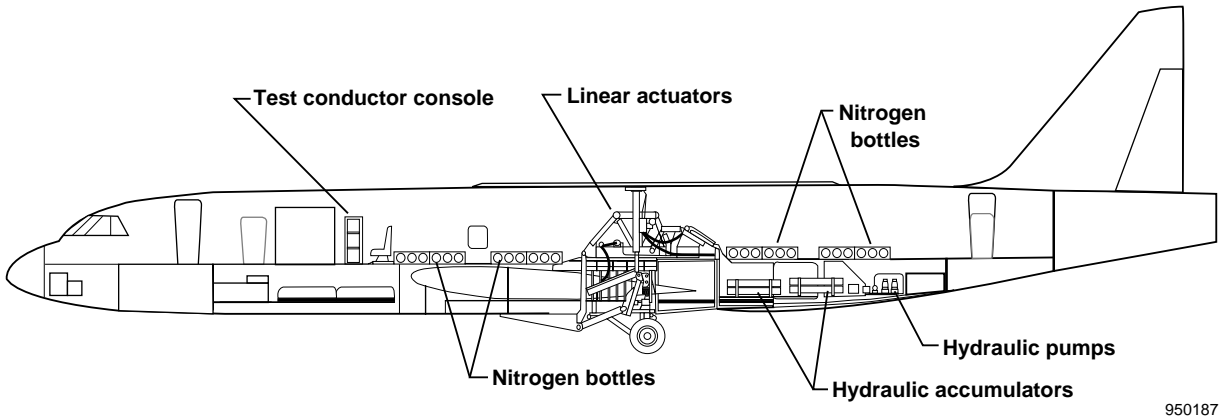
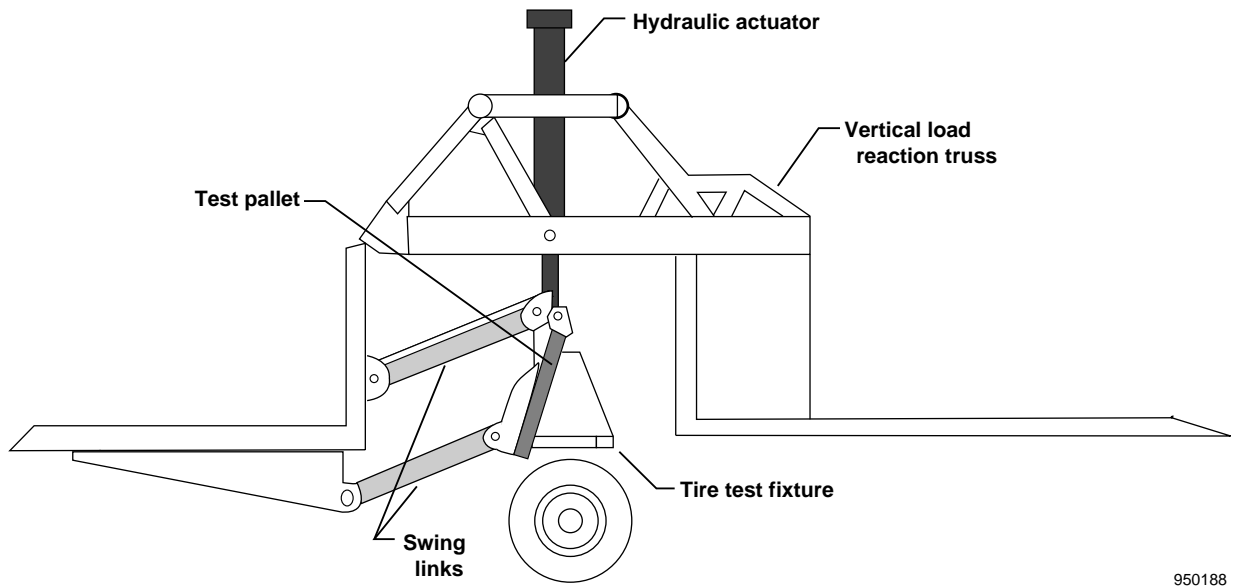

Figure 2. Primary components for the LSRA test fixture system.



950188

Figure 3. Mechanical test system of the CV990 LSRA.

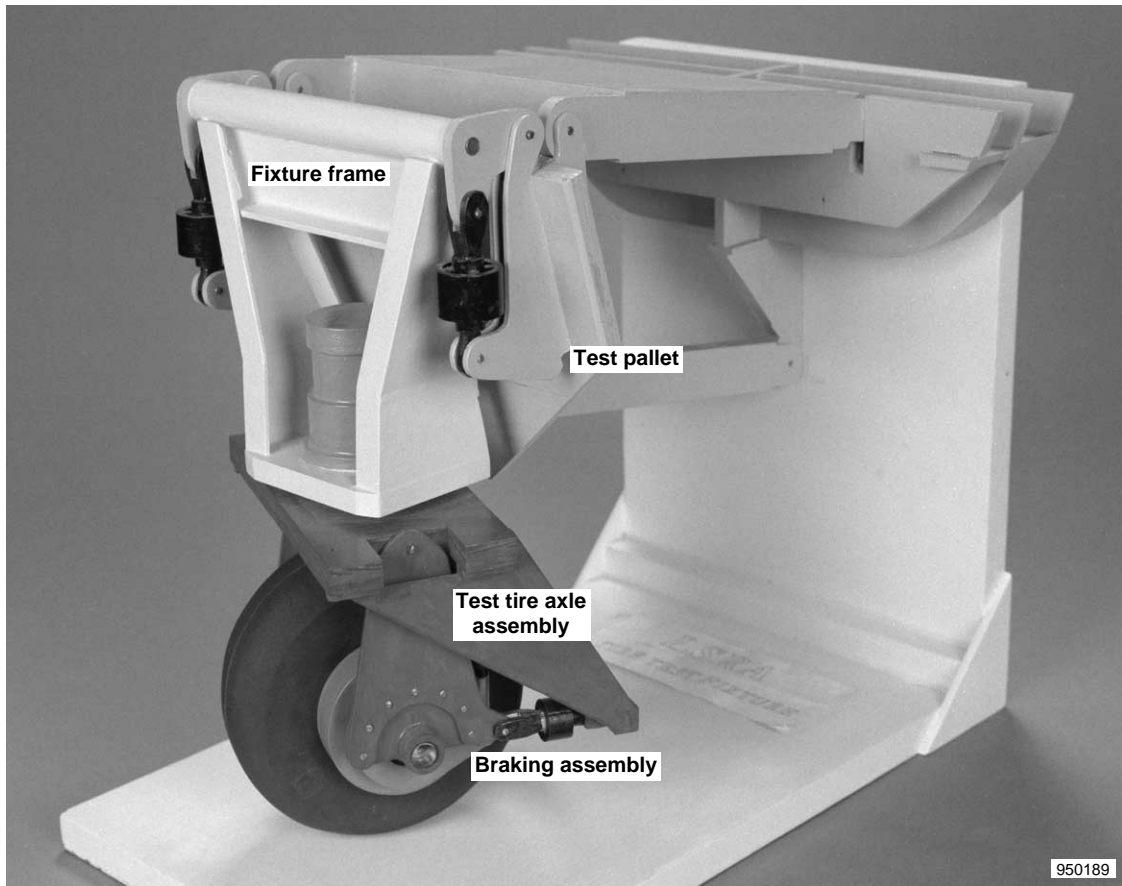
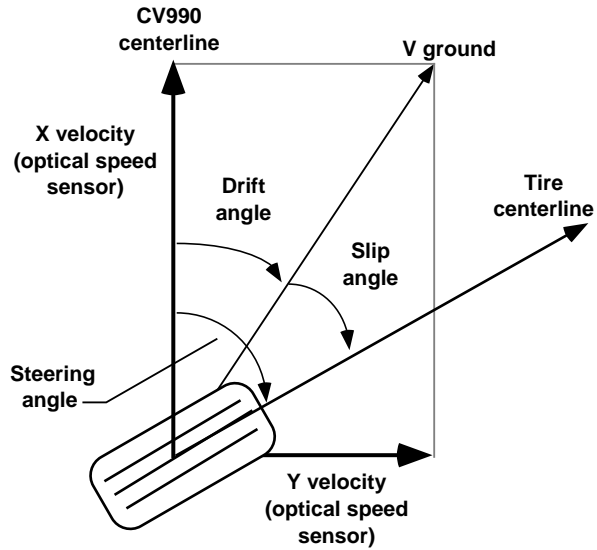

Figure 4. Single tire fixture.



Note: All angles shown in positive direction.  
 Slip angle = steering angle – drift angle

950190

Figure 5. Parameters used to determine the test tire slip angle.

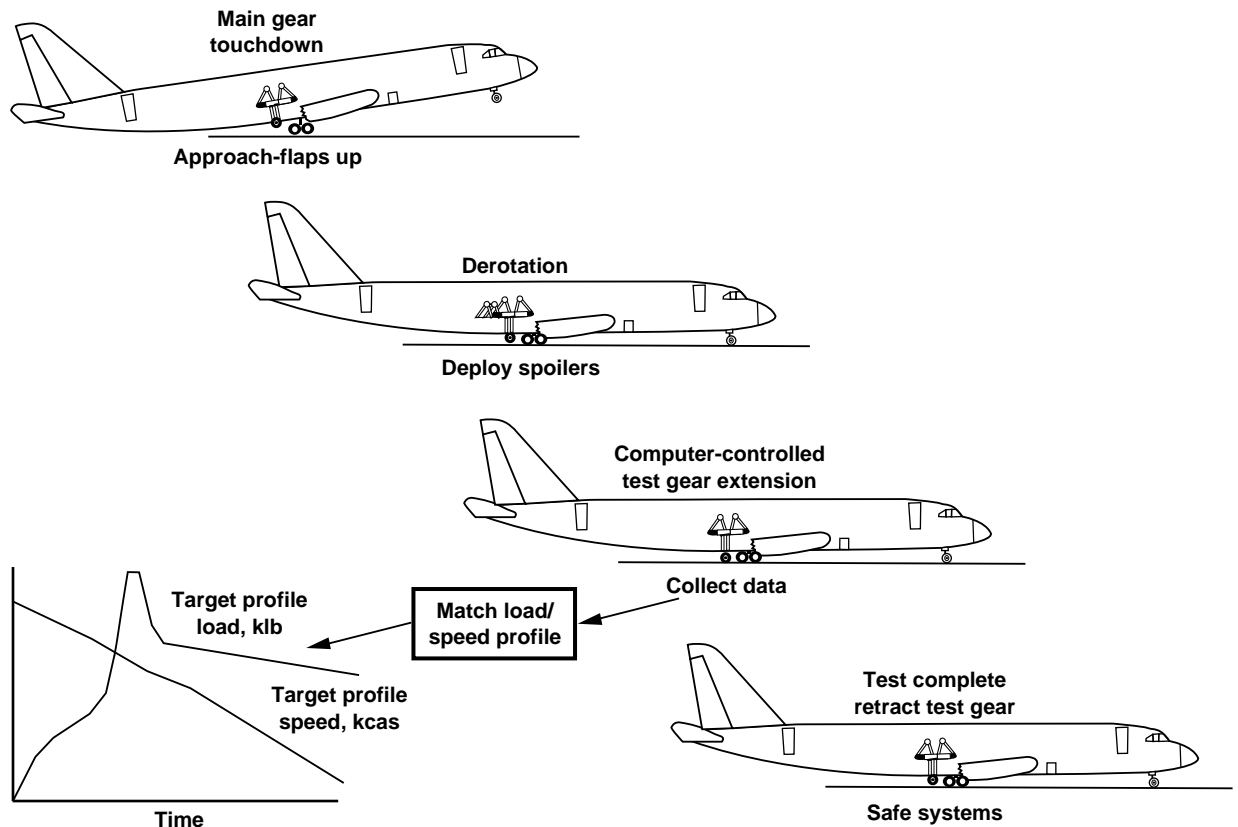

950191

Figure 6. Typical landing sequence for an LSRA.

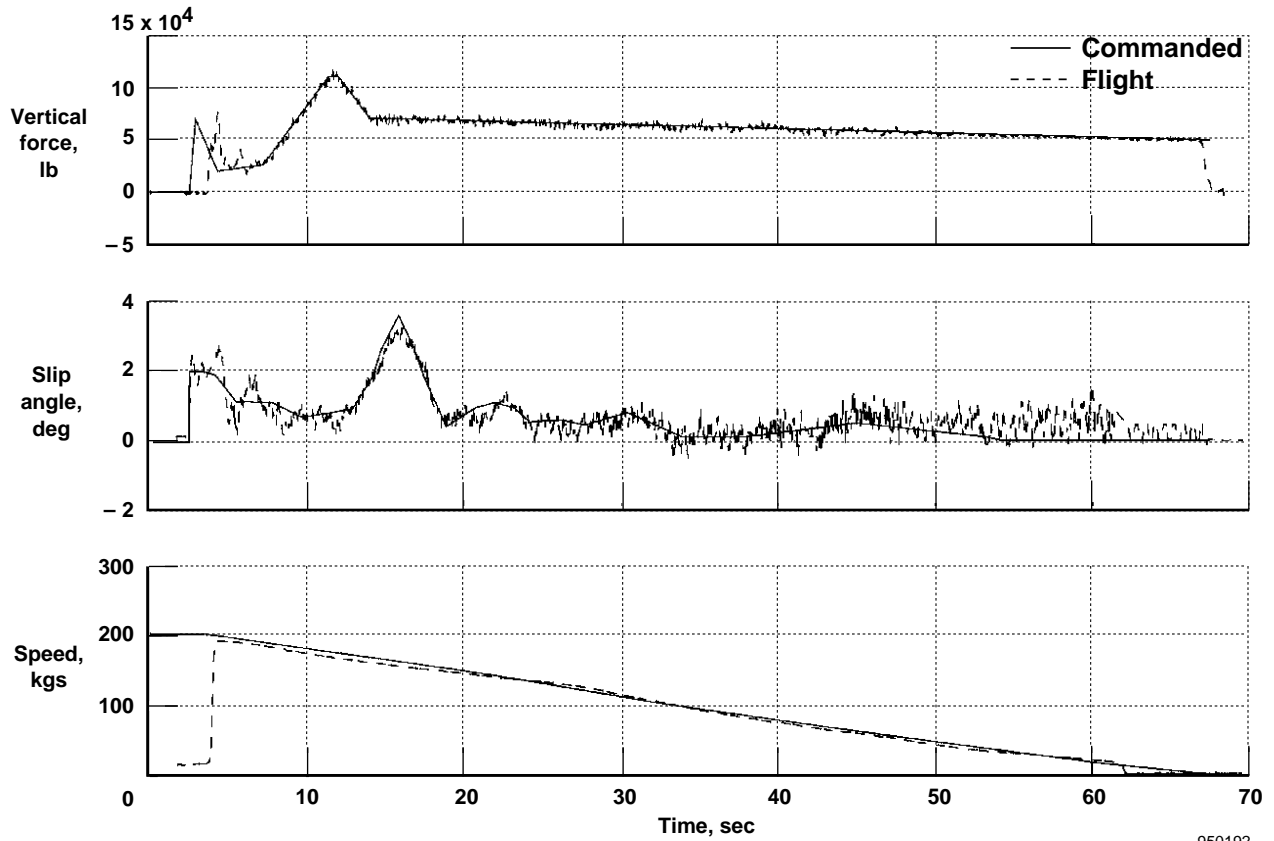

950192

Figure 7. LSRA/STS 51-D validation test.

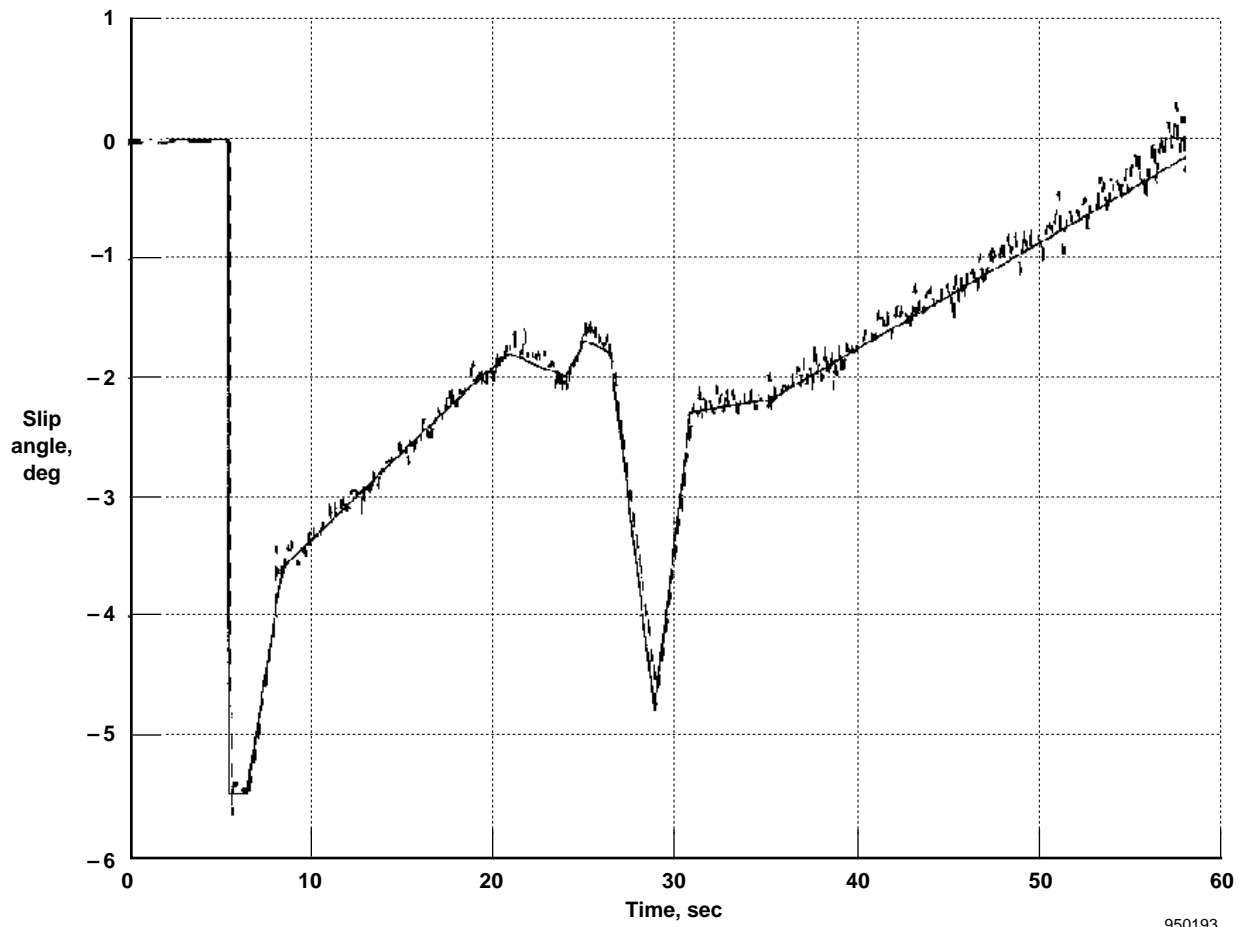

950193

Figure 8. Slip control after control system improvements.



**LSRA  
tire**



**Orbiter  
tire**

950194

Figure 9. Comparison between Orbiter STS 51-D tire and LSRA tire from validation test.



## APPENDIX A

This appendix shows a typical large aircraft tire dynamometer at the DoD Landing gear test facility which is managed by the Flight Dynamics Laboratory at Wright - Patterson AFB, Ohio. Some tire testing on the Space Shuttle Orbiter Program has been done here.

### 350 mph/120 inch Tire Test Dynamometer

#### Test Machine

350 mph/120 inch Tire Test Dynamometer

#### Applications

This computer controlled “state-of-the-art” machine is intended for high-speed takeoffs and landings or long distance taxi roll testing of aircraft tires. Critical speed/standing wave tests are also possible. An automated handling system for the large carriage removes hot tires to cooling stations and inserts cool ones ready for testing. Thus, inactive dynamometer time is kept to a minimum. Controlled constant side load is possible on the large carriage through variable yaw.

#### Machine specifications.

Large carriage:	Tire size	18 to 57 in. diameter
	Radial load	150,000 lb, maximum (programmable)
	Sink rate	3-1/2 ft/s, maximum (programmable)
	Camber	$\pm 20^\circ$ (programmable)
	Yaw	$\pm 20^\circ$ (programmable)
Small carriage:	Tire size	14 to 57 in. diameter
	Radial load	84,000 lb, maximum (programmable)
	Camber	$\pm 15^\circ$ , manually preset
	Yaw	$\pm 15^\circ$ , manually preset
Flywheel:	Diameter	120 in. (168 rev/mile)
	Width	24 in.
	Speed range	0 to 350 mph (programmable)
	Accel./Decel. rate	24 ft/s, maximum (programmable)

## Data Collection

Sampling can be done by various computers and information stored on a magnetic disc. Data is transferrable to magnetic tape in customer's format. Resolution is one percent or better, of full-scale readings.

## Accessories

Flywheel flat plates and video monitoring. Provision to mount either "lab" or aircraft wheels and heating (ambient to 300 °F) and cooling (ambient to -65 °F) chambers for thermal preconditioning of the tire.

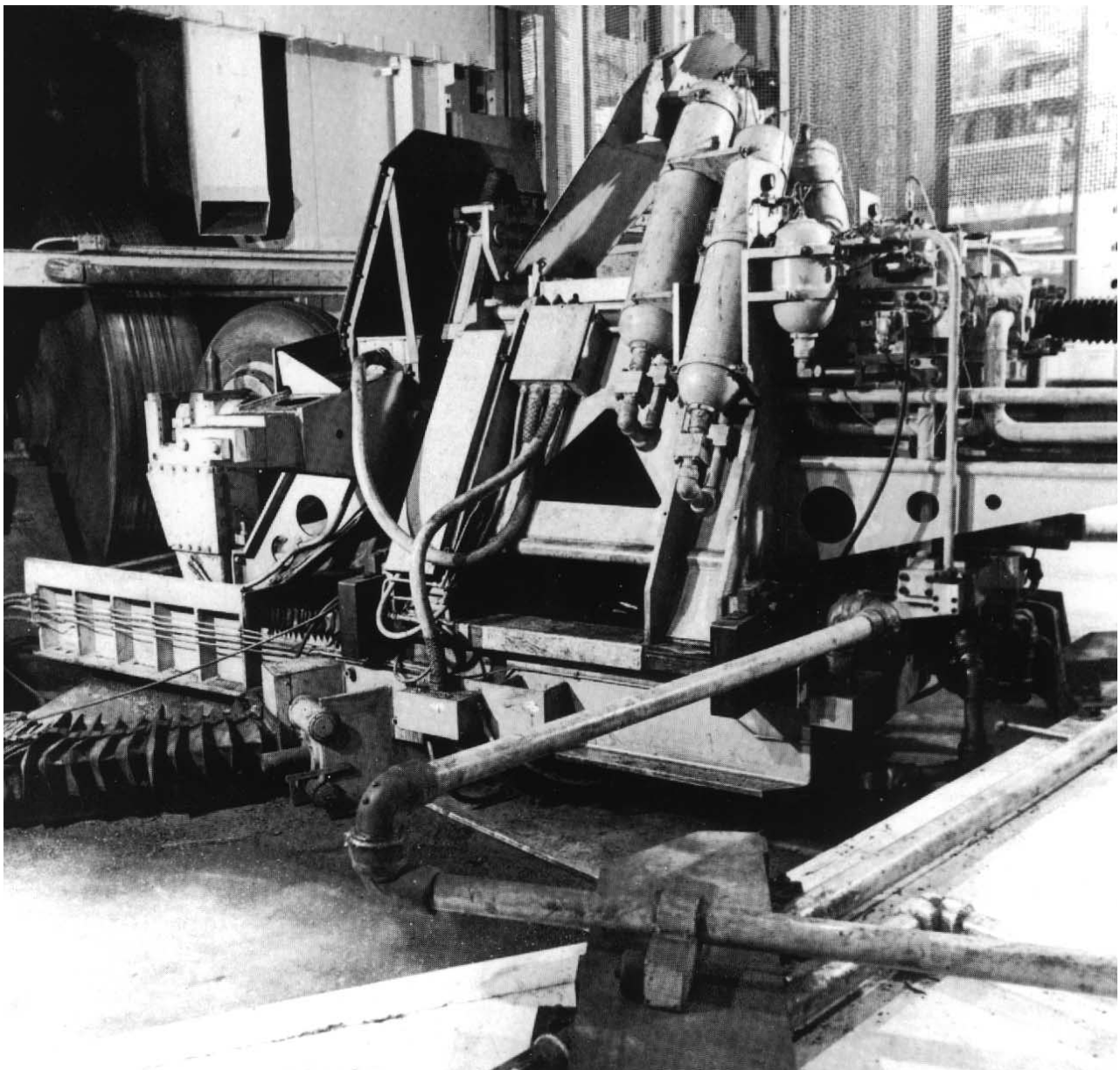

Figure A-1. Large carriage, DoD Landing Gear Test Facility.

## APPENDIX B

These equations were taken from the flight 77 flight report on the CV990 program. They give a typical example of the data reduction used for the CV990 data. These equations correct and convert the measured loads to the test tire axes.

### LSRA Parameters and Plot Descriptions

Note: All data have been thinned to 50 samples per second.

AIR1P	Test tire internal air pressure in psia. This measurement is transmitted from the rotating test tire to the aircraft by an FM transmitter. Occasionally, the receiver would not lock on the transmission frequency and the receiver would pick up a local FM radio station. For this reason, the internal pressure (and temperature) are not always accurate. These occasions are identified in the text under “Anomalies - Data System”.
AIR1T	Test tire internal air temperature in degrees F. See discussion of accuracy for AIR1P.
DIST	An optical measurement of the distance between the test tire axle and the ground in inches. A bias of 19.5 in. needs to be applied to the measurement.
GCANGLE.S	Commanded tire slip angle in degrees.
GCSPEED.S	Commanded aircraft speed in knots.
GCVLOAD.S	Commanded vertical load in lb.
PITCH	Aircraft pitch angle in degrees as measured by the Inertial Navigation System. Nose up is positive.
PYRO2	Test tire tread temperature in degrees F measured by a pyrometer pointed at the center of the tire about 150 degrees aft of the contact patch.
TBRKP	Test tire brake pressure in psig.
TGBANK.M	Aircraft roll angle in degrees (positive right wing down) as determined from differential main gear strut extensions:  $TGBANK.M = \arctan[(\text{left mg ext.} - \text{right mg ext.})/239]$
TG_GROS_VERT	Uncorrected vertical load in lb determined from summing the left and right vertical load cells.

TGNETDRAG.M Corrected test tire drag in lb. Positive force is aft. Corrections are made for transforming the body axis measurements into the test tire axis. The transformation equation is:

$$\begin{aligned} \text{TGNETDRAG.M} = & \text{DRAGFORCE}/\cos(\text{PITCH}) \\ & + (\text{VERTFORCE} * \sin(\text{PITCH}) * \cos(\text{PSI})) \\ & - (\text{VERTFORCE} * \sin(\text{PSI}) * \sin(\text{BANK})) \\ & + (\text{VERTFORCE} * \sin(\text{FORKANGLE}) * \cos(\text{PSI})) \end{aligned}$$

- 1) DRAGFORCE = TG\_GROS\_DRAG - DRAGBIAS
- 2) VERTFORCE = 1.02 \* (TG\_GROS\_VERT - VERTBIAS)
- 3) SIDEFORCE = TG\_GROS\_SIDE - SIDEBIAS
- 4) PSI is the tire steering (not slip) angle
- 5) THETA.M was substituted for PITCH when the INS angle measurement failed
- 6) FORKANGLE =  $-(0.15 + 4.7e-05 * \text{DRAGFORCE})$
- 7) BANK = TGBANK.M +  $2.7e-05 * \text{SIDEFORCE}$
- 8) DRAGBIAS, VERTBIAS, and SIDEBIAS are biases applied to the load cells as determined from zero force conditions

TGNETSIDE.M Corrected test tire side force in lb. Positive force is left. Corrections are made for transforming the body axis measurements into the test tire axis. The transformation equation is:

$$\begin{aligned} \text{TGNETSIDE.M} = & [\text{SIDEFORCE} - (\text{VERTFORCE} * \sin(\text{BANK})) \\ & - (\text{DRAGFORCE} * \sin(\text{PSI}))]/\cos(\text{PSI}) \\ & + (\text{VERTFORCE} * \sin(\text{PITCH}) * \sin(\text{PSI})) \end{aligned}$$

- 1) DRAGFORCE = TG\_GROS\_DRAG - DRAGBIAS
- 2) VERTFORCE = 1.02 \* (TG\_GROS\_VERT - VERTBIAS)
- 3) SIDEFORCE = TG\_GROS\_SIDE - SIDEBIAS
- 4) PSI is the tire steering (not slip) angle
- 5) THETA.M was substituted for PITCH when the INS angle measurement failed
- 6) BANK = TGBANK.M +  $2.7e-05 * \text{SIDEFORCE}$
- 7) DRAGBIAS, VERTBIAS, and SIDEBIAS are biases applied to the load cells as determined from zero force conditions

TGNETVERT.M Corrected test tire vertical force in lb. Positive force is up. Corrections are made for transforming the body axis measurements into the test tire axis. The transformation equation is:

$$\begin{aligned} \text{TGNETVERT.M} = & \text{VERTFORCE} * \cos(\text{PITCH}) * \cos(\text{BANK}) \\ & - (\text{DRAGFORCE} * \sin(\text{PITCH}) * \cos(\text{BANK})) \\ & + (\text{SIDEFORCE} * \sin(\text{BANK}) * \cos(\text{PITCH})) \end{aligned}$$

- 1) DRAGFORCE = TG\_GROS\_DRAG - DRAGBIAS
- 2) VERTFORCE = 1.02 \* (TG\_GROS\_VERT - VERTBIAS)
- 3) SIDEFORCE = TG\_GROS\_SIDE - SIDEBIAS
- 4) PSI is the tire steering (not slip) angle
- 5) THETA.M was substituted for PITCH when the INS angle measurement failed

- 6)  $BANK = TGBANK.M + 2.7e-05 * SIDEFORCE$   
 7) DRAGBIAS, VERTBIAS, and SIDEBIAS are biases applied to the load cells as determined from zero force conditions

TGSPEED.M	Aircraft ground speed in knots as measured by the Inertial Navigation System.
TLGRPM	Test wheel RPM in revolutions per minute. The measurement is made by counting magnetic pulses as the wheel turns. Because of the electronics used in counting the pulses, there is some delay as the wheel begins to turn.
THETA.M	Aircraft pitch angle in degrees as computed from the aircraft landing gear strut positions. The equation is:  $THETA.M = \arctan[(NG \text{ strut} - ((LMG \text{ strut} + RMG \text{ strut})/2) - 18.5)/686.3]$
TLGAY	Test landing gear pallet lateral acceleration in G's. The measurement is shown primarily to determine if the test gear is in a quasi-static condition. Test gear side forces under high lateral accelerations must be modified by an inertial correction. The magnitude of this correction is unknown but could be as high at $\pm 4000$ lb.

# REPORT DOCUMENTATION PAGE

Form Approved  
OMB No. 0704-0188

Public reporting burden for this collection of information is estimated to average 1 hour per response, including the time for reviewing instructions, searching existing data sources, gathering and maintaining the data needed, and completing and reviewing the collection of information. Send comments regarding this burden estimate or any other aspect of this collection of information, including suggestions for reducing this burden, to Washington Headquarters Services, Directorate for Information Operations and Reports, 1215 Jefferson Davis Highway, Suite 1204, Arlington, VA 22202-4302, and to the Office of Management and Budget, Paperwork Reduction Project (0704-0188), Washington, DC 20503.

1. AGENCY USE ONLY (Leave blank)		2. REPORT DATE June 1995	3. REPORT TYPE AND DATES COVERED Technical Memorandum	
4. TITLE AND SUBTITLE  The NASA Landing Gear Test Airplane			5. FUNDING NUMBERS  WU 551-15-01	
6. AUTHOR(S)  John F. Carter and Christopher J. Nagy				
7. PERFORMING ORGANIZATION NAME(S) AND ADDRESS(ES)  NASA Dryden Flight Research Center P.O. Box 273 Edwards, California 93523-0273			8. PERFORMING ORGANIZATION REPORT NUMBER  H-2045	
9. SPONSORING/MONITORING AGENCY NAME(S) AND ADDRESS(ES)  National Aeronautics and Space Administration Washington, DC 20546-0001			10. SPONSORING/MONITORING AGENCY REPORT NUMBER  NASA TM-4703	
11. SUPPLEMENTARY NOTES  John Carter: NASA Dryden Flight Research Center, Edwards, CA 93523-0273. Christopher Nagy: PRC Inc., Edwards, CA 93523-0273.				
12a. DISTRIBUTION/AVAILABILITY STATEMENT  Unclassified—Unlimited Subject Category 33			12b. DISTRIBUTION CODE	
13. ABSTRACT (Maximum 200 words)  A tire and landing gear test facility has been developed and incorporated into a Convair 990 aircraft. The system can simulate tire vertical load profiles to 250,000 lb, sideslip angles to 15 degrees, and wheel braking on actual runways. Onboard computers control the preprogrammed test profiles through a feedback loop and also record three axis loads, tire slip angle, and tire condition. The aircraft to date has provided tire force and wear data for the Shuttle Orbiter tire on three different runways and at East and West coast landing sites.  This report discusses the role of this facility in complementing existing ground tire and landing gear test facilities, and how this facility can simultaneously simulate the vertical load, tire slip, velocity, and surface for an entire aircraft landing. A description is given of the aircraft as well as the test system. An example of a typical test sequence is presented. Data collection and reduction from this facility are discussed, as well as accuracies of calculated parameters. Validation of the facility through ground and flight test is presented.  Tests to date have shown that this facility can operate at remote sites and gather complete data sets of load, slip, and velocity on actual runway surfaces. The ground and flight tests have led to a successful validation of this test facility.				
14. SUBJECT TERMS  Landing gear, Aircraft tire, CV990, Space Shuttle Orbiter Test Facility, Landing Systems Research Aircraft			15. NUMBER OF PAGES 19	
			16. PRICE CODE A03	
17. SECURITY CLASSIFICATION OF REPORT Unclassified	18. SECURITY CLASSIFICATION OF THIS PAGE Unclassified	19. SECURITY CLASSIFICATION OF ABSTRACT Unclassified	20. LIMITATION OF ABSTRACT  Unlimited	