



EUROPEAN ORGANISATION FOR NUCLEAR RESEARCH

CERN PPE 93-180  
CERN/LAA-MC 93-27  
September 13, 1993

**THE NON SPARK MODE AND HIGH RATE OPERATION OF  
RESISTIVE PARALLEL PLATE CHAMBERS**

I Crotty, J. Lamas Valverde, G. Laurenti, M.C.S. Williams and A. Zichichi

LAA project, CERN, Geneva, Switzerland

**Abstract**

The good time and position resolution of the Resistive Plate Chamber (RPC) make it an attractive candidate for muon trigger systems at future colliders. However this device has severe rate problems that make it unusable above  $1 \text{ Hz/cm}^2$  in its present form. We have investigated various materials and have also discovered a new mode of operation. This has allowed us to operate the RPC at  $150 \text{ Hz/cm}^2$ . We also discuss further improvements that may extend operation to even higher rates. We also discuss spark formation and explain the cause for the abnormally late spark signals.

---

To be submitted to Nuclear Instruments and Methods in Physics Research section A

## 1. INTRODUCTION

The goal of producing a cheap particle detector that has good timing and position resolution is the dream of everyone engaged in detector development. During the last 10 years a detector known as the resistive plate chamber (RPC) has been developed by Santonico et al.[1,2] which seems to satisfy these requirements. We constructed small test RPCs and found a big discrepancy with earlier results [3], especially related to the rate dependence. We believe that the cause of this discrepancy is as follows: Bertino et al. [3] tested a small spot in the centre of a large chamber. They think that the recharging of the plate after a spark discharge is a local effect and is not influenced by the surrounding plate surface (which was not exposed to the beam in their case). In our case[4] we have a small chamber and can uniformly expose it to the beam. The large discrepancy that we found suggests that the recharging is not just a local effect, but current must also flow on the surface of the plate. Furthermore we can produce results similar to Bertino et al. if we expose only a small spot in the center of our chamber to the beam. Iori and Massa [5] tested a large chamber exposed to a flux of photons at a nuclear reactor and have measured a similar rate dependence to us. Thus our conclusion is that standard RPCs can not stand a rate above  $1 \text{ Hz/cm}^2$ .

Recently there has been another development which affects the use of RPC's at future colliders. At the SSC the background of low energy neutrons has been calculated to be  $10^6 \text{ Hz/cm}^2$ , which can be reduced to  $10^5 \text{ Hz/cm}^2$  with some modification to the layout of magnets. The probability that an RPC detects the neutron has been measured[6] to be  $6 \times 10^{-3}$ . This is believed to be due to the neutron undergoing an elastic collision in the surface layer of the resistive plate with the recoil proton entering the gas volume. Thus it appears that the background counting rate may well be in excess of  $600 \text{ Hz/cm}^2$  at future colliders.

We have decided to make a complete study of the RPC in order to shed light on many problems that still need to be understood and clarified. We have therefore constructed RPC using a variety of materials for the resistive plates and measured the rate dependence of these chambers. During the course of our experiments we have discovered a 'non-spark' mode of operation. This is of great interest because it allows us to operate at higher rates.

Finally we present some very brief results from an RPC built with plates of low resistivity glass. It maintained a good time resolution, even at a rate of  $550 \text{ Hz/cm}^2$ ; however it had a rather short lifetime, indicating that it is close to the lower limit of resistivity.

## 2. CHARGING OF THE RPC PLATES

We will first discuss the movement of charge within the RPC (shown schematically in figure 1). This will help us understand the role of the resistive plate. The RPC is a very simple detector; essentially it is two parallel plates with gas between the two plates. A voltage

is applied to the outer surfaces of two plates so that there is a large electric field across the gap. We show in figure 1(top) the voltage on the inner surfaces of the plates at the moment the high voltage is applied. A dielectric constant of 5 and a voltage of 8,000 volts is assumed. Since the plates are semiconductors, charge will move so that there is no voltage across the plates (figure 1 (middle)). A charged particle traverses the gas gap and ionises the gas. These electrons will then initiate a breakdown (spark). This spark discharge will transport electrons to the anode and positive ions to the cathode. As the resistivity of the plate is high, these electrons and ions will be deposited on the plates reducing the electric field at that spot (and thus quench the spark) (figure 1 (bottom)). The use of a quenching gas inhibits further breakdowns via the propagation of photons. This spot is recharged after some time by current flowing through the plate; there is also current flowing on the surface of the plate (or through the gas close to the surface), thus surface resistivity should play a role. Surface resistivity (and the drift speed of the charge carriers) should also play a role in the size of the spark, as the area discharged by a spark should increase for lower resistivity plates.

One is tempted to treat the recharging as a simple RC circuit. A small element of the resistive plate has a certain RC time associated with it; an element twice as big will have C a factor 2 larger and R a factor 2 smaller, and therefore have the same RC time constant. A thinner (or thicker) plate also has the same RC time constant; thus the time constant of the plate is just dependant on the bulk resistivity,  $\rho$ , and the dielectric constant,  $\epsilon$ . The rate dependence should depend on how quickly a spot is recharged and therefore depends on this RC time constant. Some authors [7,8] conclude that only the resistivity and dielectric constant of the plates define the rate capability of the RPC. However this is rather naive, as actually it is not a simple RC circuit. The charge moves between the surfaces of the resistive plate, affecting the voltage on the surface of the plate; thus it can not be treated as a simple capacitor. We have performed an experiment where we connect a 100 volt battery across a plate, and then measure the discharge time when this battery is disconnected. This is shown in figure 2. We did this by coating two surfaces of a phenolic plate with a conductor (copper and carbon both gave similar results). An oscilloscope, with a 100 M $\Omega$  impedance probe, monitored the voltage across the plate. We then opened the switch connecting the battery to the plate and observed the voltage drop. The drop in voltage is shown in figure 2 on a log scale. The area coated with conductor is 20 x 20 cm, using the bulk resistivity of  $3 \times 10^{11}$   $\Omega$  cm, this gives an internal resistance for the plate of 150 M $\Omega$ . If one calculates the capacitance using the standard formula for a plate capacitor and assumes a dielectric constant of 5, one calculates a capacitance of 2.5 pF/cm<sup>2</sup> and thus a capacitance of 1 nF for the 20 x 20 cm<sup>2</sup> plate. This gives a time constant,  $\tau$ , of 150 ms (or 60 ms if the 100 M $\Omega$  of the oscilloscope is included). Obviously figure 2 shows disagreement with this calculation. First one sees that the drop in voltage is not a simple exponential and secondly, in the most part the time constant is 10 times larger and there is a long tail. The charge does not sit on the surface of the plate, as in a

classical parallel plate capacitor, but migrates through the plate. One should not forget that this discharge time would be even longer for an isolated RPC plate, as there would not be the external  $100\text{ M}\Omega$  resistor. The rate dependence of a RPC must depend on this time constant, this measurement shows that one should take a larger time constant than one obtains from the classical calculation. We also believe that the drift speed of the charge carriers is important, and the thickness of the plates themselves must play a role. Also as we have been studying laminates, the surface resistivity compared to the bulk resistivity may change the rate behaviour.

### 3. THE CONSTRUCTION OF THE TEST CHAMBERS

The test chambers are all built in a similar way. Two plates of  $30 \times 30\text{ cm}^2$  enclose a 2 mm gas gap. This gas volume is sealed at the edge by a PVC spacer. Gas is brought into and out of this gap by a small insulated pipe through the spacer. The spacer is glued to the two plates with black RTV\*. Electrodes are painted onto the outer surfaces of the plates using nickel paint; typically the resistivity of this layer is less than  $2\Omega/\square$ . The high voltage was supplied to one side via a  $10\text{ M}\Omega$  resistor with a 1 nF capacitor decoupling the surface to ground. The other surface was directly connected to the front end electronics that had an input impedance of  $50\ \Omega$ .

Different materials were used for the construction of the chambers. The results from our first chambers, one constructed with 2 mm thick phenolic plates and another with 1.2 mm cellulose, have been previously reported [4]. We have now studied Melamine Phenolic laminates and glass. The Melamine  $[\text{C}_3\text{N}_3(\text{NH}_2)_3]$  sheet consists of an inner core of phenolic, and either one or both surfaces covered with a layer of Melamine. The Melamine layer is between 100 and 200 micron thick and is hard and shiny. It comes with a protective film of plastic, which is removed during chamber fabrication, ensuring that the surface remains clean and scratch free. Melamine is produced in a large variety of colours (we have only worked with white) and is cheap and readily available as it is used extensively in kitchens, offices and the electrical industry. The materials we tested, together with some of their properties, are listed in table 1. The value of the resistivity is a value measured in our laboratory. This was measured by painting an area of  $20 \times 20\text{ cm}^2$  on both sides of a sample of the material with conductive paint. The plate was put into a gas box, which was flushed with dry nitrogen. A voltage was applied (usually 1.5 kV) and the current measured. In general the plates were ohmic, i.e. a linear relationship between current and voltage, once a voltage greater than a few volts was applied. Usually the value of the current dropped over a couple of days before stabilising. The increase in resistivity was in some cases up to a factor

---

\* 732 RTV, Dow Corning GMBH.

5, except in the case of material D which increased by more than 2 orders of magnitude over 5 days. The value quoted for the resistivity in table 1 is the final value.

#### 4. TEST RESULTS

We tested the chambers, first with cosmic rays in the laboratory, and then in a test beam in the CERN East hall. The signal was fed through an amplifier and then to a discriminator. The signal is large and well separated from the noise and the discrimination level was set to be well above the noise level. We used a gas mixture of Argon, isobutane and freon-12. Certain chambers needed more freon added to the gas mixture to reach the highest efficiency with cosmic rays. In figure 3 we show various efficiency plateau curves obtained with cosmic rays. One can see that there is a strange drop off in efficiency for the glass RPC. This drop with increasing high voltage seems characteristic of all RPC's to some degree. We assume that increasing the voltage produces 'sparks' of increasing magnitude, and that this deadens a larger area for a longer time (i.e. that we have rate effects even with a cosmic ray flux). However it is curious that Melamine, which has a similar resistivity and thickness shows this effect to a much smaller degree. Whether this is due to a different drift velocity of charge carriers or some surface effect is hard to ascertain. Figure 3 shows that the maximum efficiency and length of the plateau depended on the gas mixture; the composition of the best gas mixture and the maximum efficiency obtained with cosmic rays is also shown in table 1. For the beam test we used the best gas mixture found from the cosmic ray tests. We used a defocused beam that was essentially uniform over a  $10 \times 10 \text{ cm}^2$  area. The rest of the chamber area was exposed to the beam at a slightly lower rate. The rate quoted is the rate during the spill in the  $10 \times 10 \text{ cm}^2$  area. The spills were 400 ms long and every 15 seconds. We measured the plateau curve at various beam intensities and plot the peak efficiency versus rate for a variety of materials. This is shown in figure 4, with a linear and logarithmic x axis. This is an overestimate of the efficiency as for most chambers the efficiency falls during the spill, however we use the same method for all the tests and at this stage we are more interested in the comparison between materials.

As can be seen from figure 4, the fall off of the efficiency with increasing rate is more rapid for RPC's built with thicker plates. There is also a dependence on the plate resistivity. We characterise this rate dependence as the rate that produces a 10% drop in the efficiency (shown by the arrow in figure 4); this is tabulated in the column marked maximum rate in table 1. The maximum efficiency for the glass RPC is low (85%) and this probably boosts the value of the maximum rate. One has an unexpected good performance of material E, which has a resistivity 6 times greater than material B, but a much better rate dependence.

In figure 4 we have plotted the maximum efficiency for various rates. However the plateau curve changes shape as the rate increases, so that the voltage needed also increases.

This is shown in figure 5 for the RPC of material D. Thus if we have a large RPC with different rates at various areas on the RPC surface, then we would not be able to reach the performance shown in figure 4 unless we could also apply different high voltages for various areas.

Obviously if the resistive plate was replaced by a conductor, the chamber can not operate anymore in this spark mode. The whole plate would be discharged for a single spark. Thus there must be a lower limit in resistivity and thickness, below which sufficient current can flow through the plate to sustain the discharge. We want to find this limit and test the performance of the RPC at this point. As yet we have not tested this limit extensively however we have an RPC fabricated with Schott glass that has a resistivity  $\rho = 3.5 \cdot 10^9 \Omega \text{ cm}$  and a thickness of 2 mm. We tested this for a short while (discussed below) before the chamber entered continuous discharge mode below the operating voltage. We assume that this must be close to the limit.

## 5. A NEW OPERATING MODE

When a charged particle passes through the gas, it leaves a trail of ionisation. For a minimum ionising particle this ionisation consists of clusters of electrons typically 300 micron apart. Since there is a strong electric field across the gap, these electrons will be accelerated and cause further ionisation through the standard avalanche mechanism. The movement of the electrons is fast compared to the positive ions, thus soon one collects the electrons on the anode and there is a cloud of positive ions in the gas close to the anode plate that extends out towards the cathode. The exact shape of this cloud will depend on the distribution of primary ionisation, but will be most dense close to the anode. These positive ions will increase the field at the cathode at this point and if the field is sufficiently intense electrons will be pulled out of the cathode. These electrons will start avalanching and feed into the positive ion cloud and eventually the ion density becomes so high that a conducting plasma is formed - this is the spark signal. If one reduces the voltage across the gas gap then in some cases the cloud of positive ions will not increase the field enough to start the field emission of the electrons. The positive ions will drift towards the cathode. The field increases as the positive ions approach the cathode and this can start field emission which eventually leads to spark formation. Thus, at a reduced voltage, one expects fewer, delayed sparks as the drift of positive ions is slow. If we look at an RPC signal with the voltage set somewhere on the rising edge of the efficiency plateau, we should see sometimes only the avalanche and no spark signal and in other cases an avalanche followed by a delayed spark signal. In figure 6 we show four spark signals; the oscilloscope is triggered by a cosmic passing through external scintillators. It is difficult to see the early signal from the avalanche signal (the shaded area has been added to show the position); the spark signal, however, is clearly seen. The tremendous jitter in the time of the spark signal is evident. We have increased the sensitivity of the oscilloscope and

show in figure 7 the 'avalanche' signals. When working on the efficiency plateau in 'spark' mode one assumes that the gas gap is so overvolted that electrons can be pulled out of the cathode wherever the cloud of positive ions happens to be. Thus, at suitable high voltages, one has good timing of the spark signal. The avalanche signal that precedes it is hidden by the far larger spark signal. However, we have observed a large tail of late pulses, especially when operating at higher rates. We assume that this is because the voltage across the gas gap is reduced and the spark formation will rely on the movement of the positive ion cloud towards the cathode. There is also the case where the primary ionisation consists of a single cluster of electrons close to the anode; thus the avalanche will produce only a small cloud of positive ions close to the anode, therefore a small percentage of late spark pulses are expected even at low rates with the high voltage set on the efficiency plateau. As can be observed in figure 7 the timing of the avalanche signal is much more precise. Obviously the best results will be obtained if one uses a constant fraction discriminator. In the remaining time we had in the test beam we were only able to test the properties of this mode using a fast charge amplifier and a standard simple threshold discriminator. We believe that there is a large contribution to the time distribution from threshold slewing.

These small pulses we call 'avalanche mode', to distinguish them from the large pulse 'spark mode'. We do not use the label 'proportional', because although the multiplicative process is similar to the proportional tube, the size of the pulse is certainly not proportional to the amount of ionisation - the size of an avalanche produced by a single electron will depend on the position of the electron within the gas gap. Figures 6 and 7 were produced by connecting the oscilloscope directly to the read out pad of the RPC with the signal terminated by  $50 \Omega$ . Thus we see that a typical 'spark' signal is 50 pC and an 'avalanche' signal is 2.5 pC; we would expect a 20 fold gain in the rate capability.

The circuit of the fast charge amplifier was designed by Rudge [9], and the schematic is shown in figure 8. Using this amplifier we found a dramatic improvement in the rate capability. We also found that the chamber worked with less quencher and hence lower voltage. Typically we ran the chambers with a mixture of 81% Argon, 13% isobutane and 6% Freon-12. The exact value of the threshold is unknown, as the amplifier was uncalibrated. However we set the threshold as low as possible consistent with zero counting rate when we decreased the high voltage. The threshold must have been of the order of 0.5 pC. In figure 9 we show the comparative rate capability of two chambers operating in pure 'spark' mode compared with operating in 'avalanche' mode. The maximum rate increases by roughly 20 as expected.

The timing response of the RPC in 'spark' mode is good, however it rapidly deteriorates with increasing rate as we [4] and Iori and Massa [5] have shown. We have measured the time spectrum of the RPC-material D working in this 'avalanche' mode. We

measured the response of the chamber during the spill and find that after the first 50 ms of the spill the chamber is stable regarding timing and efficiency. We have therefore analysed the events that occur after 200 ms after the spill start. We show the timing spectra for various rates in figure 10. To get an idea of how the chamber behaves at low rates, we have histogrammed the timing of the first 10 events of each spill using just the two lowest rate runs; we use this data as the 1 Hz / cm<sup>2</sup> points in figure 11. In figure 11 we show the change in mean position of the time spectrum and the FWHH versus rate. We expect that this will substantially improve if a constant fraction discriminator is used, as the voltage across the gas gap reduces with increasing rate, and smaller pulses are produced with increased time slewing. The goal of the next beam test will be to study this.

## 6. INITIAL TESTS OF RPC BUILT WITH SCHOTT GLASS 8540

We have built an RPC using Schott glass type 8540. The ingot of glass was ordered from Schott, which was then cut and polished into 4 sheets, 2 mm thick, of dimension 15 x 15 cm<sup>2</sup>. The glass sheets were transparent and looked similar to normal commercial glass for windows. Due to the limited size of the pieces of glass we could only make a chamber that had a sensitive area of 11 x 11 cm<sup>2</sup>. Again we used a PVC frame and a 2 mm gas gap. We examined this chamber using this avalanche mode and the gas mixture of 81% Argon 15% isobutane and 4% Freon-12. The chamber worked well initially, but after an hour started to draw continuous current at our working voltage. This current increased until we could no longer operate the chamber. We do not know if this current was produced by a continuous discharge within the sensitive area of the chamber or by breakdown across the spacer (frame); we will investigate further, but as the glass plates are glued to the spacer, it will need careful handling in order to open the chamber. During this hour of operation we managed to take some data. We observed a 25% drop in efficiency going from 9 Hz / cm<sup>2</sup> to 550 Hz / cm<sup>2</sup> (which is very similar to the RPC-material D). However the timing spectra were significantly improved. We show the spectra in figure 12 for 9 Hz / cm<sup>2</sup> and 550 Hz / cm<sup>2</sup>. The shift in timing is 3 ns and the FWHH increased by only 0.7 ns. This is an improvement of 20 compared to the RPC-material D.

## 7. DISCUSSION

We have found a material, melamine, more suitable for RPC construction than phenolic. The resistivity of melamine laminate is higher than phenolic, however the rate capability of a 1 mm sheet of melamine composite is an order of magnitude better than phenolic. We want to understand the reasons for this and further tests are in progress. The resistivity is a measure of the density of charge carriers - while we believe that the drift speed of the charge carriers and plate thickness are more important. It could also be that the surface



resistivity is higher so that charge from a smaller area is fed into the spark (and thus produces a smaller spark signal).

We have also discovered that it is possible to operate the chamber in a different mode, the 'avalanche mode'. This allows us to work at a rate 20 times higher, thus for our melamine chamber we can run at 150 Hz/cm<sup>2</sup> with only a 10% drop in efficiency. Of course one has to use better electronics to realise this, however the signal is sufficiently large that this will not substantially add to the cost of the read out electronics. It also has the added advantage that much less quencher is required and operates at a lower voltage. We suspect that the rate performance can be improved, both by decreasing the thickness of the plate and by improving the electronics. We had a single pad of 22 x 22 cm<sup>2</sup> with the pre-amplifier attached. Certainly we can reduce the noise by improved shielding and by using read-out strips, which should act as transmission lines. This avalanche mode is the same mode of operation as parallel plate chambers, PPC, with metallic plates [10]. The PPC has a much faster signal than we observed with our RPC. Typical risetimes are 2 ns and a width at the base of the pulse of 7 ns for Fe<sup>55</sup>. The pulses shown in figure 7 are slower and broader, however we have a 2 mm gap (compared to 1 mm for the PPC), a minimum ionising particle (thus primary ionisation spread across the gas gap), and a large pad of 22 x 22 cm<sup>2</sup> (compared to 6 x 6 cm<sup>2</sup> of the PPC). We believe that the biggest contribution is from the size of the pad, and hope that read out strips will help. Compared to the PPC we are working at much higher gains, the resistive plates help quench the discharge. Sparks hinder but do not destroy the operation of the RPC in this mode. However the high gain has big advantages, the first being simpler electronics with better signal to noise. The typical signal of the PPC is between 2 and 60 fC for a minimum ionising particle, while at present we are working with 2 pC. The other advantage is that the PPC has to be constructed with tight mechanical tolerances. A gain change of 30% corresponds to a change of 6 micron of the 1 mm gap. Obviously these tolerances can not be met if one builds chambers of large dimensions; higher gas gain is less sensitive to gap width.

We have not fully studied the possibility of a better gas. One problem is that since we do not work in a pure avalanche mode, there is a certain probability of forming a spark. This probability is rate dependant and drops with increasing rate. These sparks are limiting the rate behaviour of the RPC and would create large clusters of hits when using a strip read out. Thus we have started to test other gases such as CF<sub>4</sub>-CO<sub>2</sub> (80:20), which shows a promising spark suppression behaviour for Parallel Plate Chambers [11]. We assume that also the chamber will work even better in 'avalanche' mode with a thicker gas gap, as the amount of primary ionisation will be increased. We would also be less sensitive to fluctuations in the distribution of the primary electrons. A larger gap should also help suppress spark formation.

The results from the rather brief life of the Schott Glass RPC indicate that the efficiency at high rates may not be improved by the lower resistivity substrate - this rather

surprising result needs to be checked. However the timing spectra are much less rate dependant - one naively expects that both effects should be related to keeping the voltage across the gas gap, thus further investigation indeed is required.

We are approaching the efficiency required to operate at the LHC in the presence of a large neutron background. Our test chambers of  $30 \times 30 \text{ cm}^2$  appear to have a uniform response even in this avalanche mode. Obviously further tests have to be performed to see if these excellent results can be produced for large chambers built using the cheap manufacturing processes of the more conventional RPC. We believe that using thinner resistive sheets, improved electronics, a larger gas gap and a wise choice of gas could give even better performance. As a final note it should be pointed out that we have the pickup strips directly connected to the resistive plate. This is slightly different from the 'standard' RPC which has a resistive carbon layer to supply the voltage to the plate, followed by external pickup strips. Thus we should have better signal to noise, and less spreading of pulse to adjacent strips.

### **Acknowledgements**

We are grateful to Mr. Meoni of Pol-Hi-Tech for suggesting and supplying the first sheet of Melamine. As usual we have enjoyed the excellent services of the PS test beams in the East Hall, and thank everyone involved that makes this possible.

## References

1. R. Santonico and R. Cardarelli, Nucl. Instr. and Meth. 187 (1981) 377;
2. R. Cardarelli, A. di Biagio, A. Lucci and R. Santonico, Nucl. Instr. and Meth. A263 (1988) 20.
3. M. Bertino et al., Nucl. Instr. and Meth. A283 (1989) 654.
4. I. Crotty, J. Lamas Valverde, G. Laurenti, M.C.S. Williams and A. Zichichi, Nucl. Instr and Meth. A329(1993)133
5. M. Iori and F. Massa, Nucl. Instr. and Meth A306 (1991) 159.
6. E. Pless, Talk given at International Resistive Plate Chamber Workshop, Rome, 18-19 February 1993
7. W.B. Atwood et al., Nucl. Instr and Meth 206(1983) 99-106
8. M. Anelli, G. Bencivenni, G. Felici and L. Magro, Nucl. Instr and Meth A300(1991) 572-574
9. A. Rudge, A Fast Low Noise Charge Amplifier, Proceedings of the Third Annual Conference on Electronics for Future Colliders - 1993. LeCroy Corporation, Chestnut Ridge, New York.
10. Y. Galaktionov, Y. Kamyshev, A. Malinin and V. Pojidaev, Nucl. Instr. and Meth. A317 (1992) 116.
11. A Measurement of the First Townsend Coefficient in  $\text{CF}_4$ ,  $\text{CO}_2$  and  $\text{CF}_4/\text{CO}_2$  mixtures at high, uniform electric field, RD5 Collaboration, CERN-PPE/93-82 and subm. to Nucl. Instr. and Meth.

	Material	Thickness	Resistivity $\Omega$ cm	Maximum Efficiency	Rate for 10% eff. drop	Best Gas mixture argon : isobutane : freon
A	Phenolic	2.0 mm	$3 \cdot 10^{11}$	94 %	0.6 Hz / cm <sup>2</sup>	60 : 30 : 3
B	Cellulose	1.2 mm	$5.6 \cdot 10^{12}$	95 %	0.6 Hz / cm <sup>2</sup>	66 : 28 : 6
C	Mel-Phenolic-Mel	3.0 mm	$1.6 \cdot 10^{13}$	94 %	0.35 Hz / cm <sup>2</sup>	44 : 52 : 4
D	Mel-Phenolic-Mel	1.2 mm	$2 \cdot 10^{13}$	94 %	10.5 Hz / cm <sup>2</sup>	44 : 52 : 4
E	Melamine-Phenolic	0.9 mm	$3.3 \cdot 10^{13}$	91 %	11.5 Hz / cm <sup>2</sup>	72 : 24 : 4
F	Glass (mirror)	3.0 mm	$9.9 \cdot 10^{12}$	85 %	0.8 Hz / cm <sup>2</sup>	42 : 50 : 8
G	Schott Glass	2.0 mm	$3.5 \cdot 10^9$	-	-	-

TABLE 1

Notes for Table 1

**Material A :** Phenolic sheet available at CERN stores. The value of  $3 \cdot 10^{11} \Omega$  cm was obtained in 1992. The stock this year has a resistivity of  $1 \cdot 10^{12} \Omega$  cm, and we have not succeeded in building a working chamber with this higher resistivity.

**Material B :** The cellulose sheets constructed into a chamber were supplied to us by Pol-hitech. More details of this chamber can be found in reference [4]. The value of the resistivity is higher than previously reported, which was  $0.9 \cdot 10^{12} \Omega$  cm. The lower value was obtained at the start of the measurement, while the value in the table is a final value obtained after 36 hours.

**Material C :** This is commercially known as 'Umaboard', available from local supplier Angst et Pfister.

**Material D :** This is known as double sided Argolite, and was specially produced for us, bought through Bernard Bourquin SA, 32, chemin Adrien-Stössel, CH-1217 Meyrin.

**Material E :** This is single sided Argolite 217-HG, available from local supplier: Bernard Bourquin SA, 32, chemin Adrien-Stössel, CH-1217 Meyrin.

**Material F :** These glass plates were bought as mirrors from MIGROS. The layer of paint on the back surface was removed exposing a layer of aluminium. A border (2 cm wide) was etched away in this aluminium layer. This layer was then used as the pickup and high voltage electrode.

**Material G :** This is Schott glass type 8540. A block of this was manufactured in the laboratory of Schott, which was then cut and polished into plates by Guinchard SA

## FIGURE CAPTIONS

- Figure 1. Movement of charge in an RPC.
- Figure 2. Discharge of a phenolic plate.
- Figure 3. Plateau curves for glass and melamine RPC's using cosmic rays with a variety of gas mixtures
- Figure 4. Efficiency versus rate for a variety of plate materials.
- Figure 5. Efficiency versus voltage for various rates.
- Figure 6. 4 typical pulses from an RPC showing the avalanche and spark pulse. The oscilloscope is directly connected to the anode of the RPC with a 50  $\Omega$  termination.
- Figure 7. 5 typical pulses from an RPC showing the avalanche pulse. The oscilloscope is directly connected to the anode of the RPC with a 50  $\Omega$  termination.
- Figure 8. Circuit diagram of fast, low-noise charge amplifier.
- Figure 9. Comparative efficiencies versus rate for the two modes of operation - 'spark' and 'avalanche'. The upper plot is for material 'D' and the lower is for material 'C'.
- Figure 10. Timing spectra of RPC working in 'avalanche' mode for various rates.
- Figure 11. The delay and increase in FWHH of the timing spectra as a function of rate.
- Figure 12. Timing Spectra at two rates for the Schott glass RPC.

**Initial condition after applying high voltage**

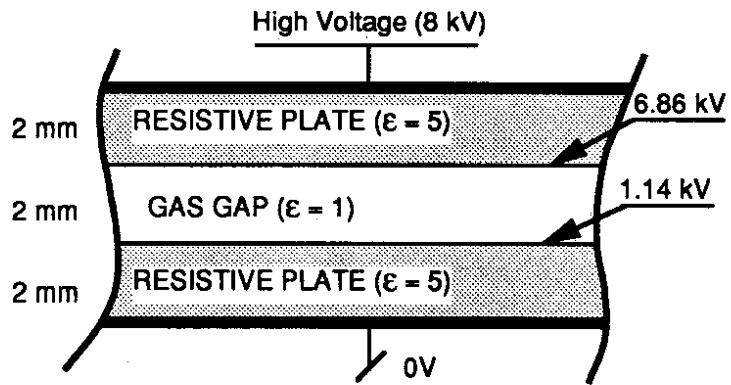

**Surface of plates will be charged by current flow through the plates**

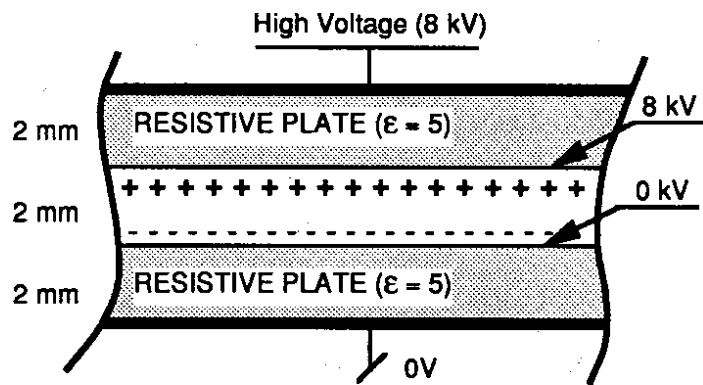

**After 'spark' discharge electrons deposited on anode and positive ions on cathode**

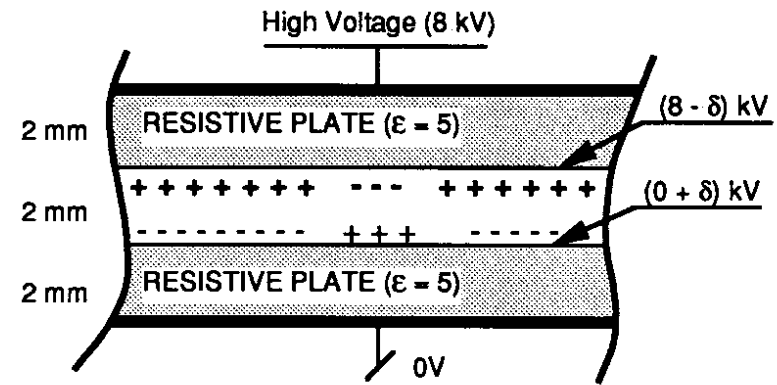

FIGURE 1

Phenolic sheet 2 mm thick

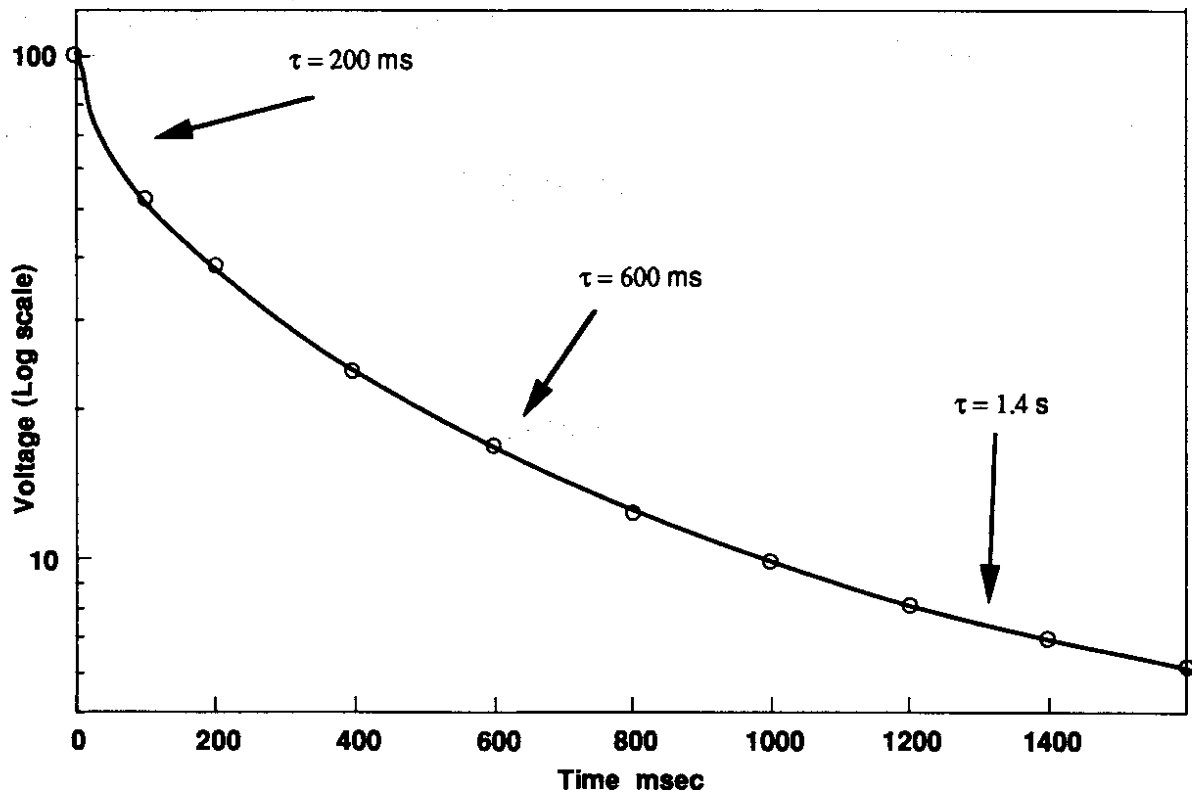
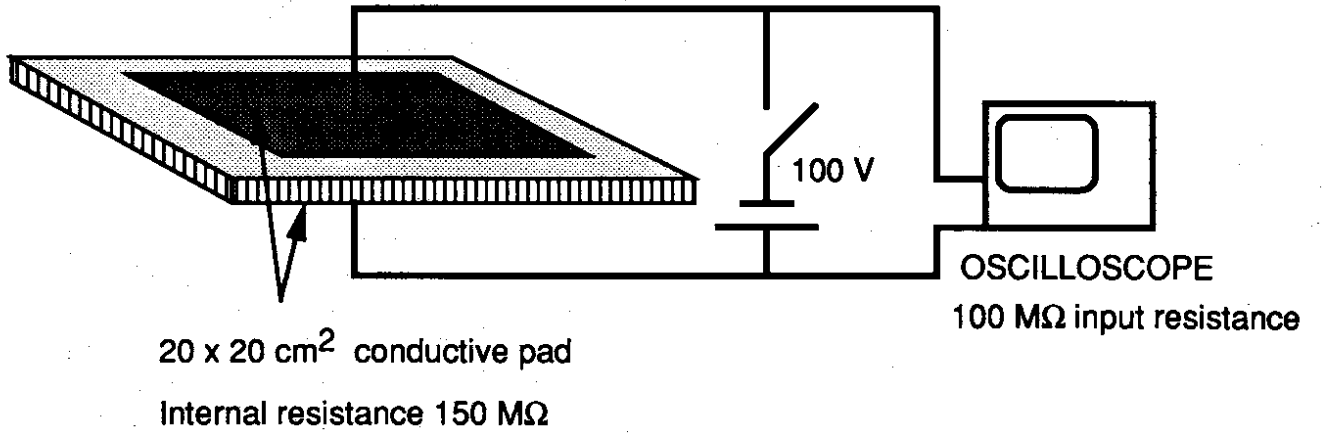

FIGURE 2

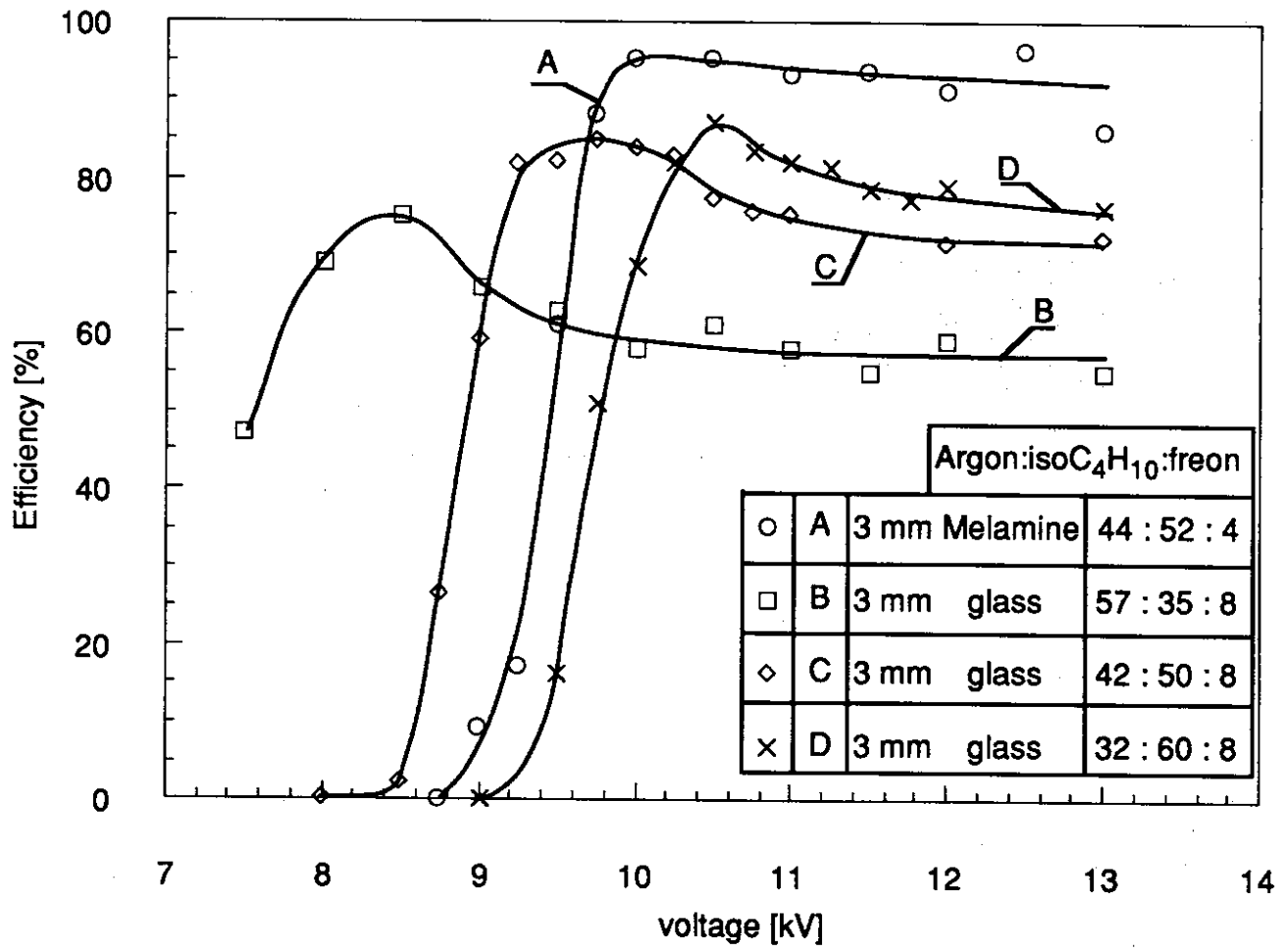

FIGURE 3



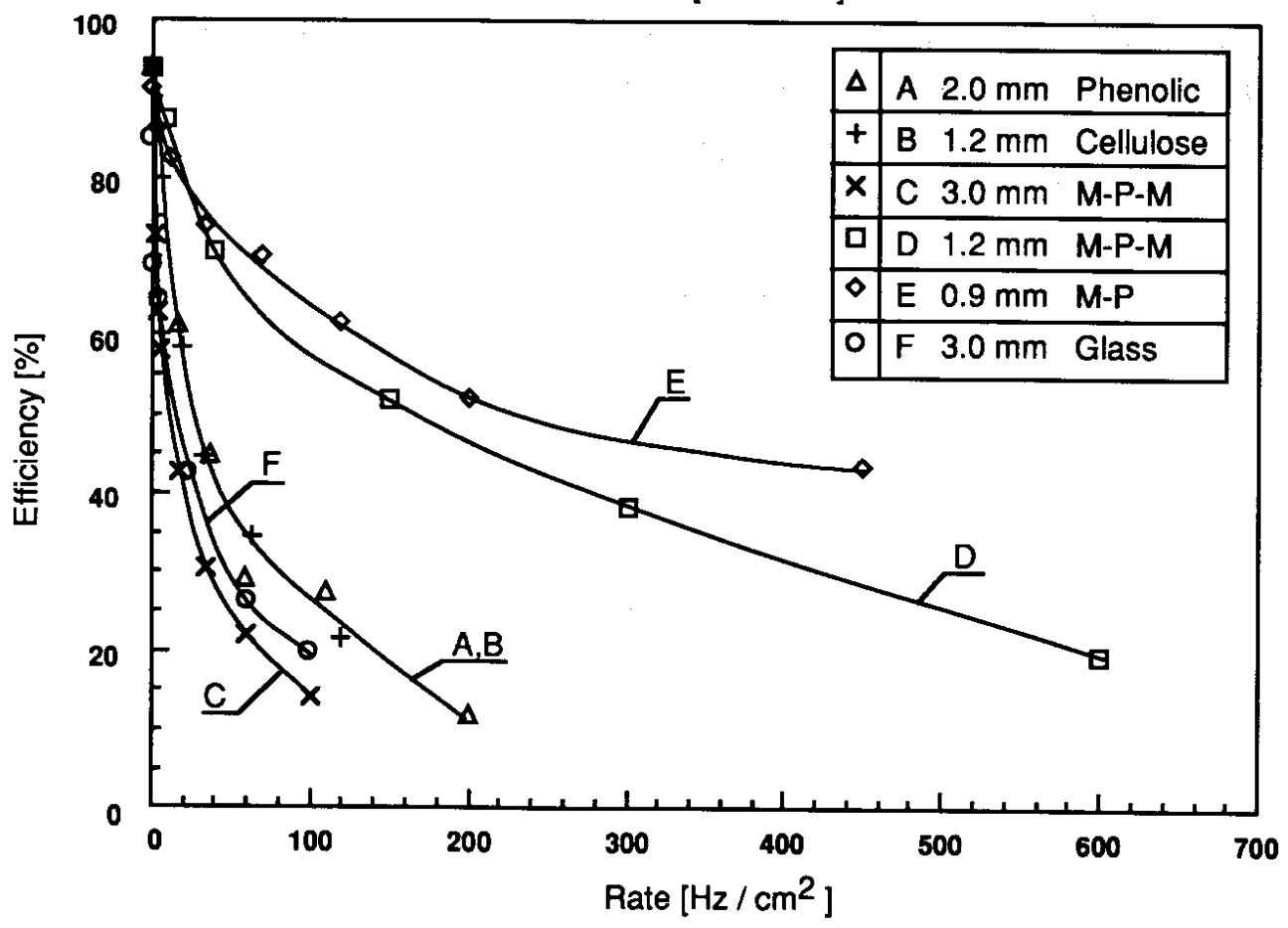
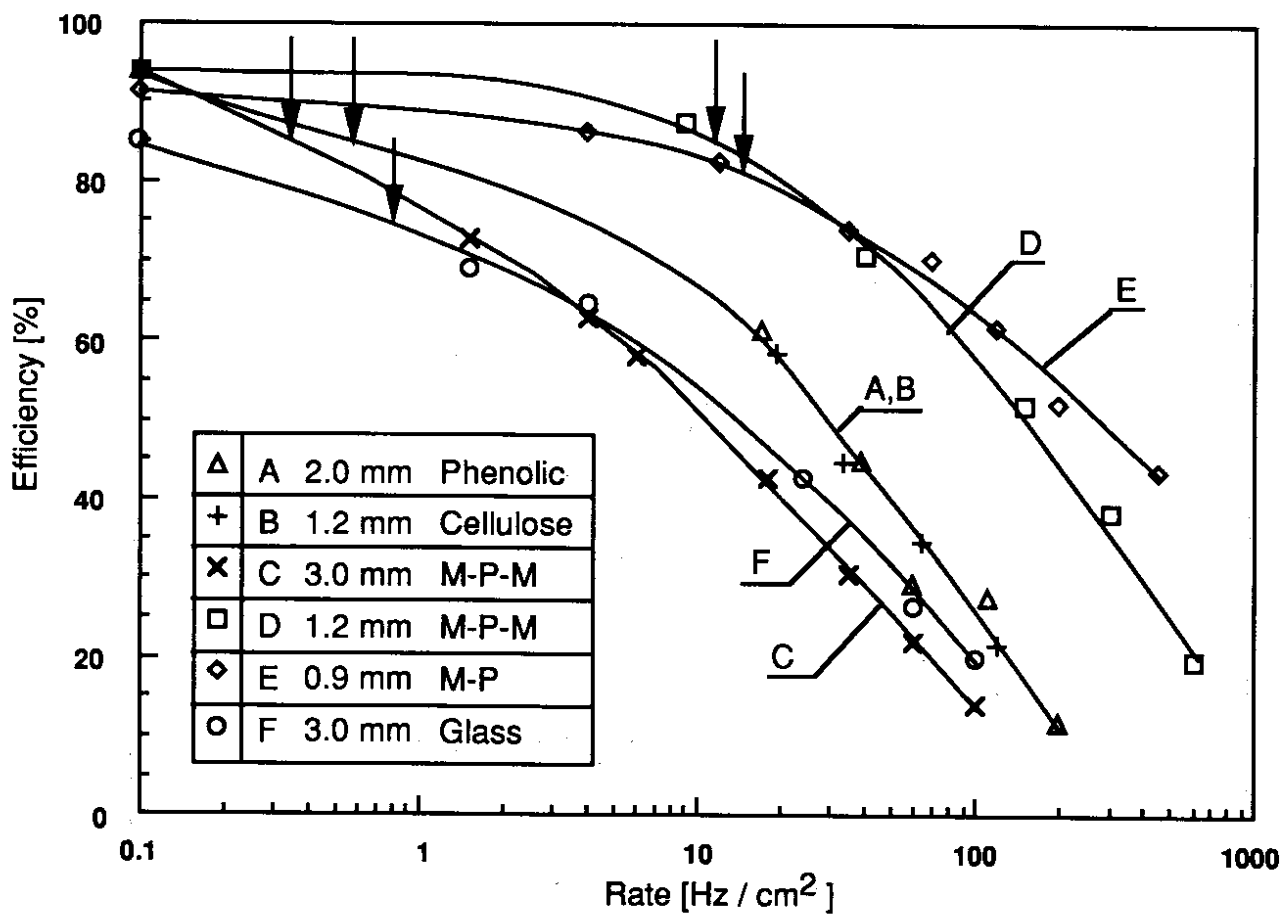

FIGURE 4

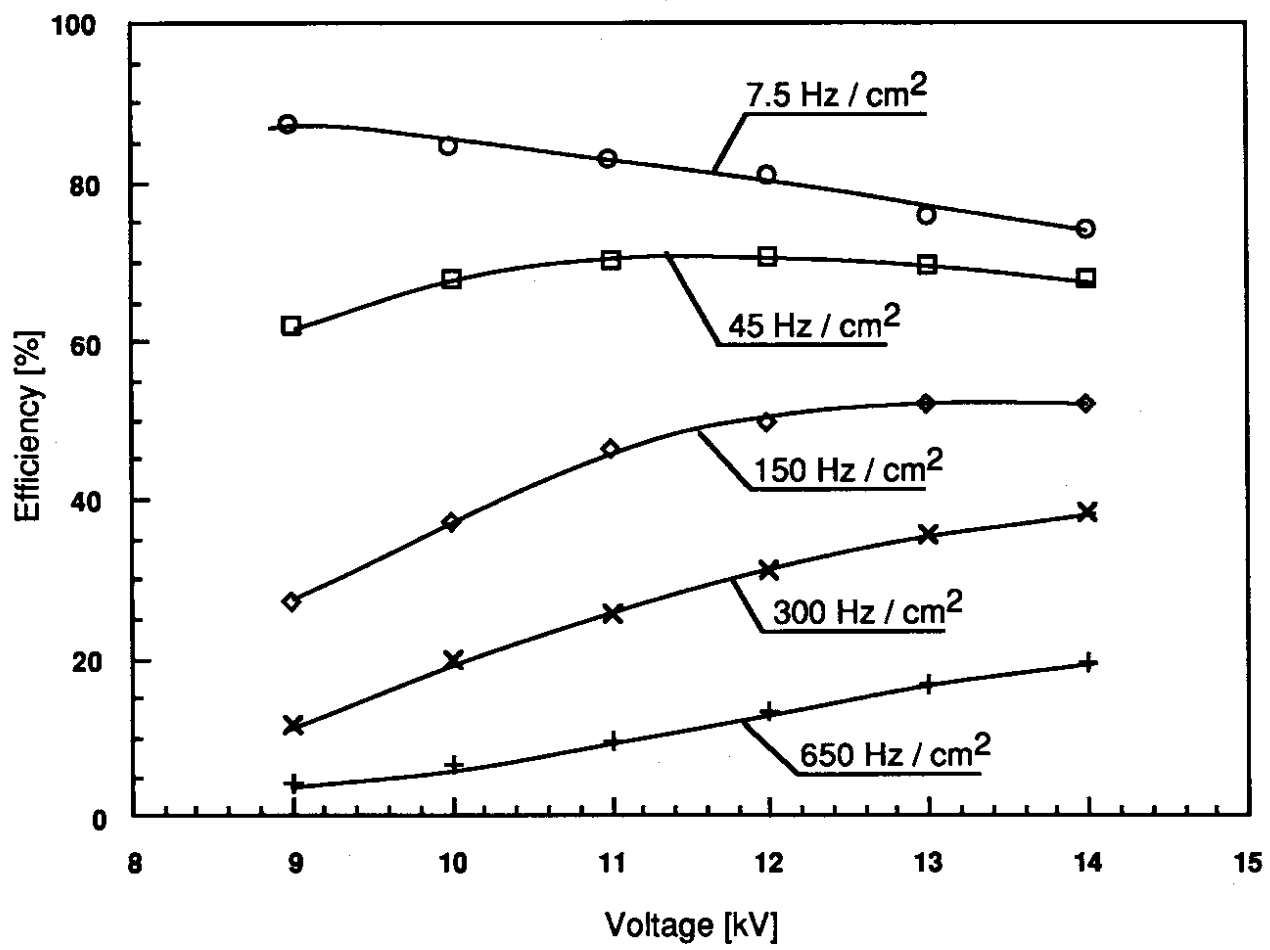

FIGURE 5

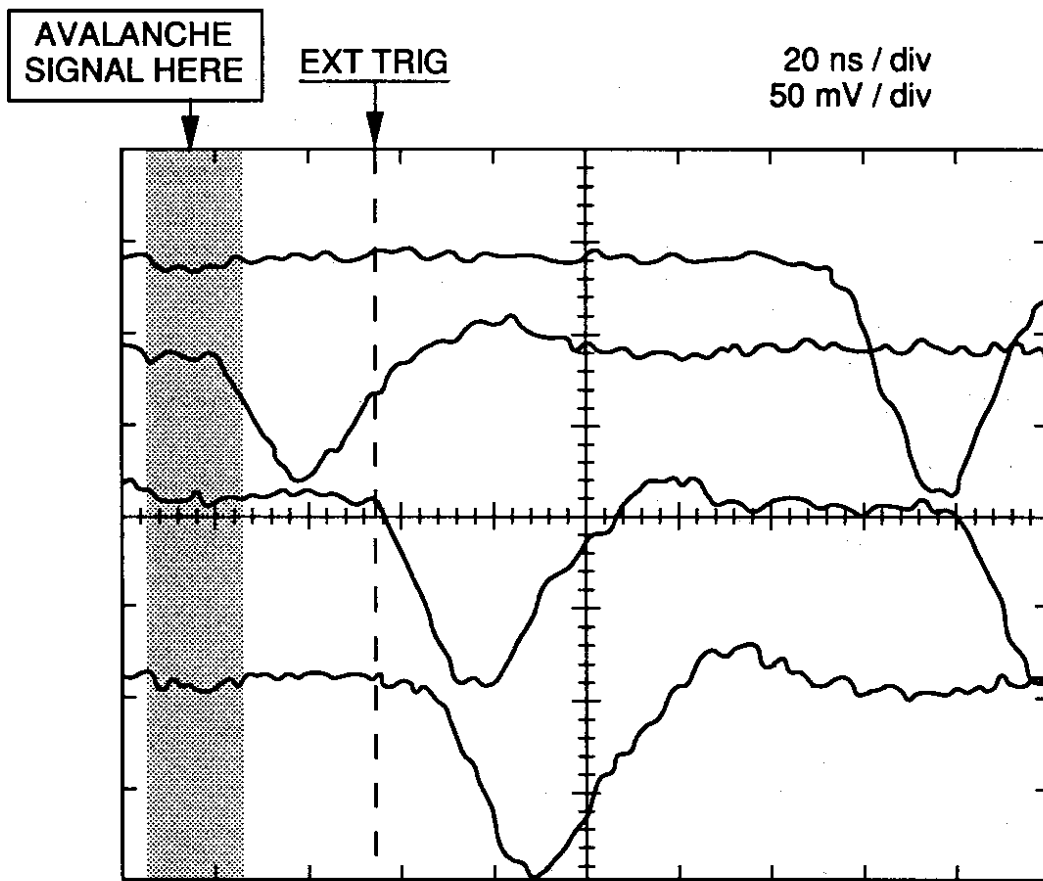

FIGURE 6

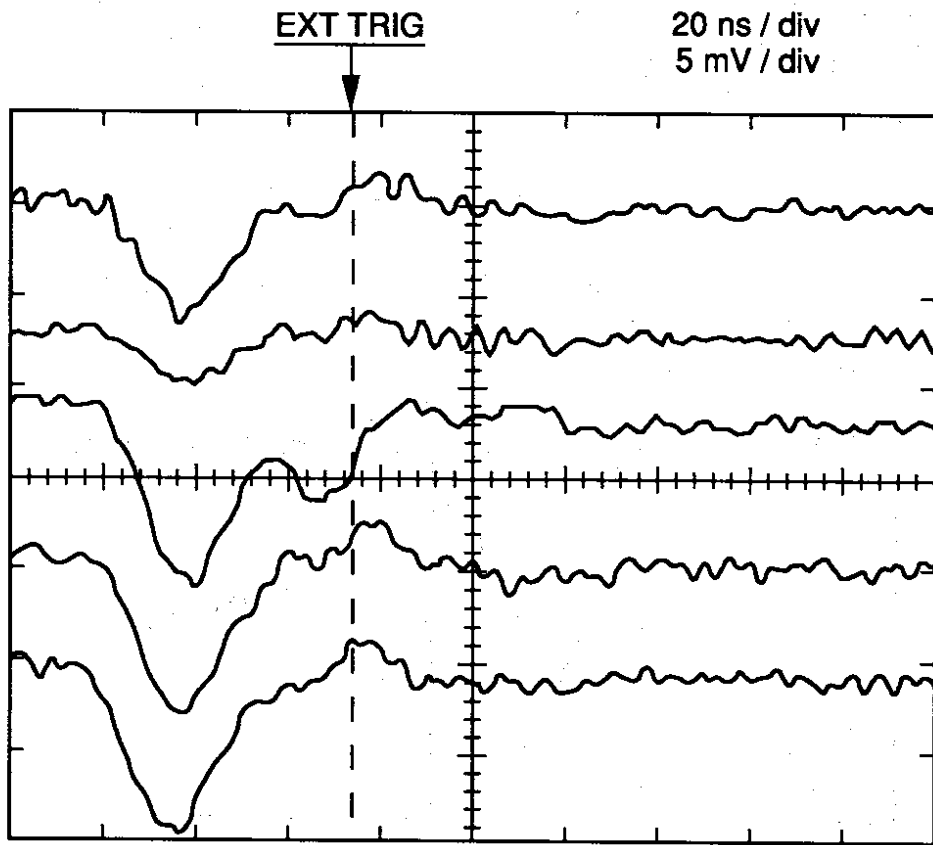

FIGURE 7

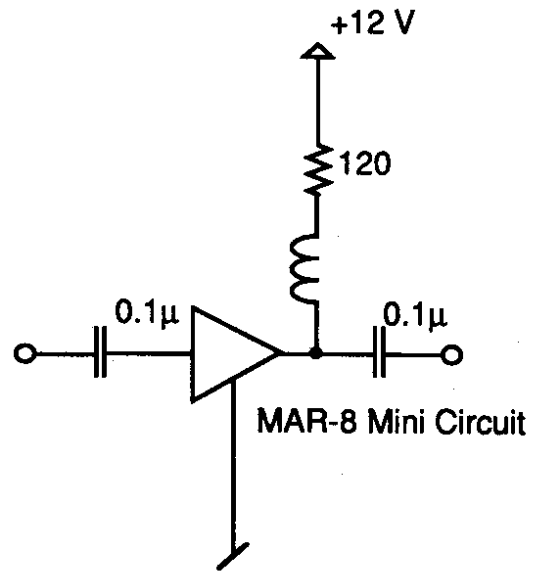
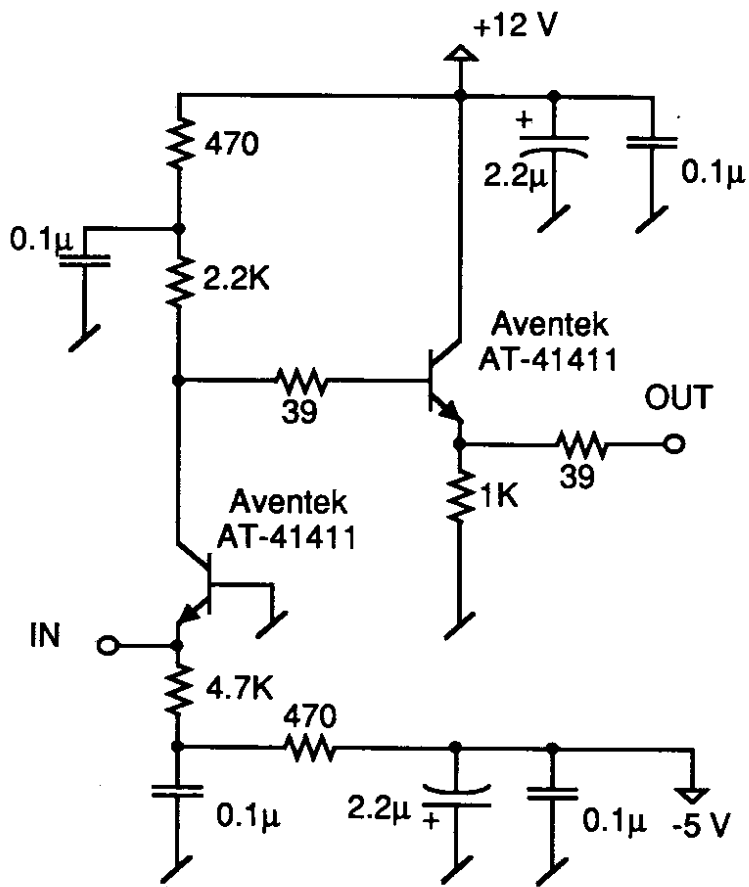

FIGURE 8

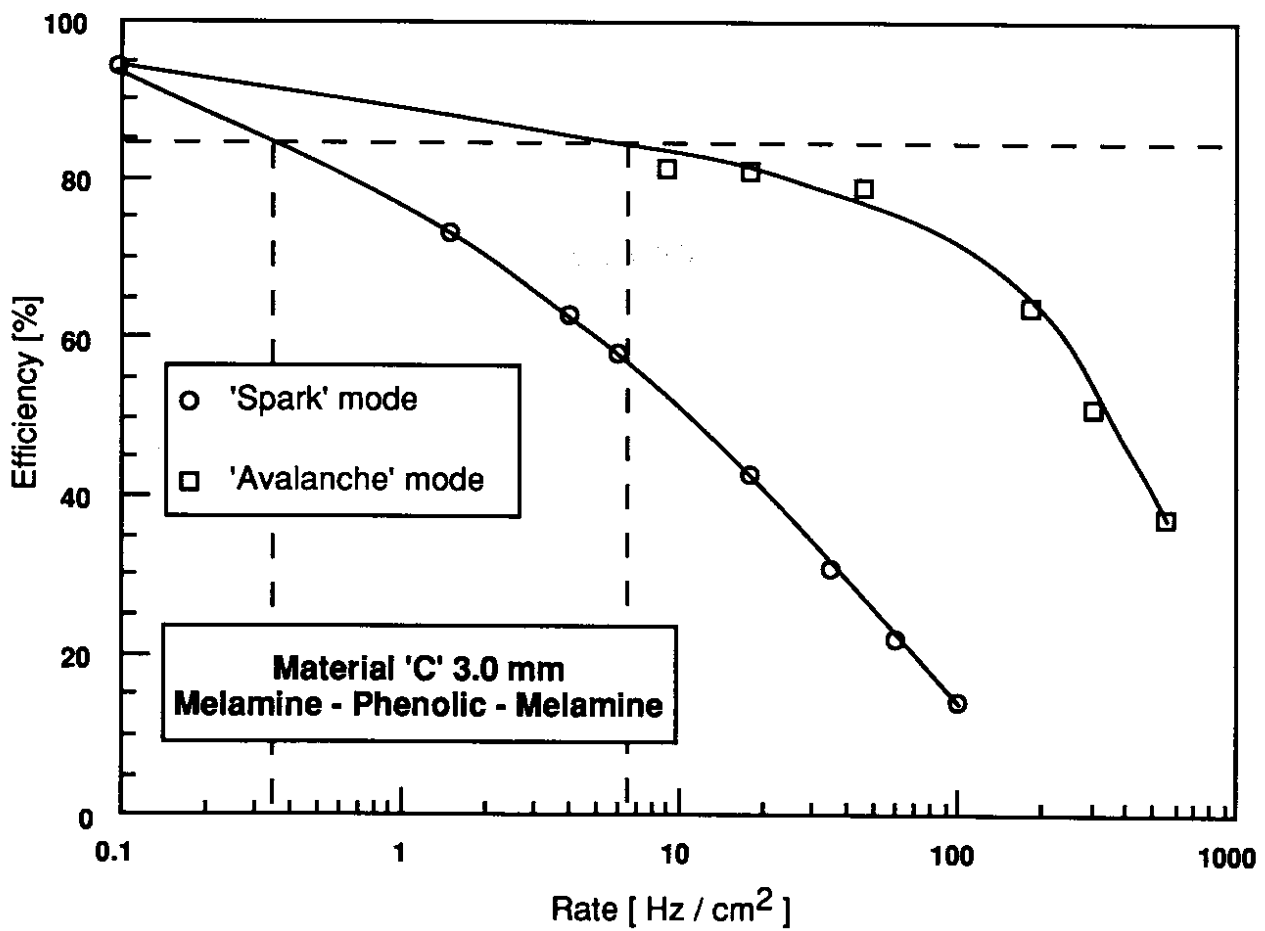
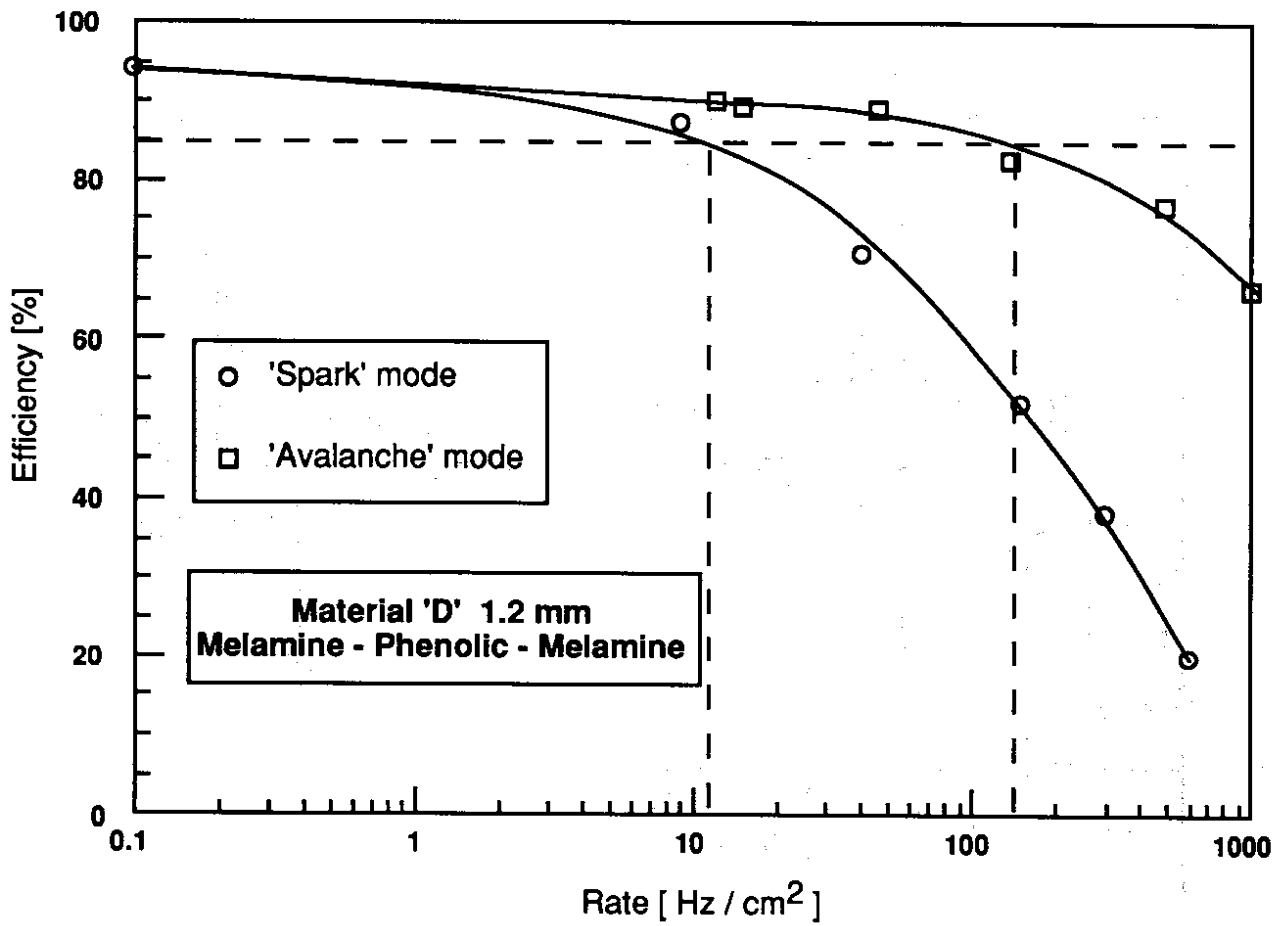

FIGURE 9

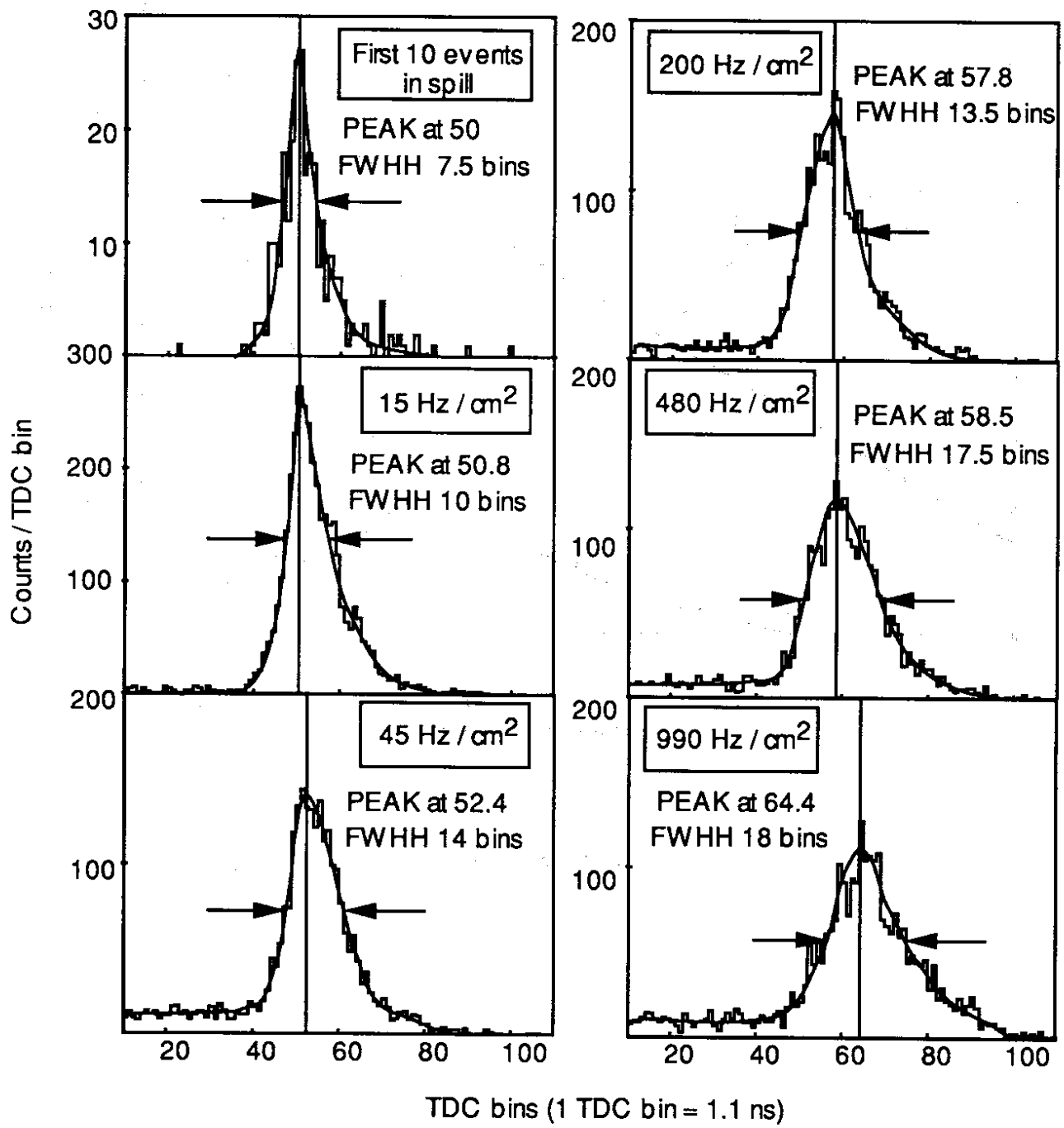

FIGURE 10

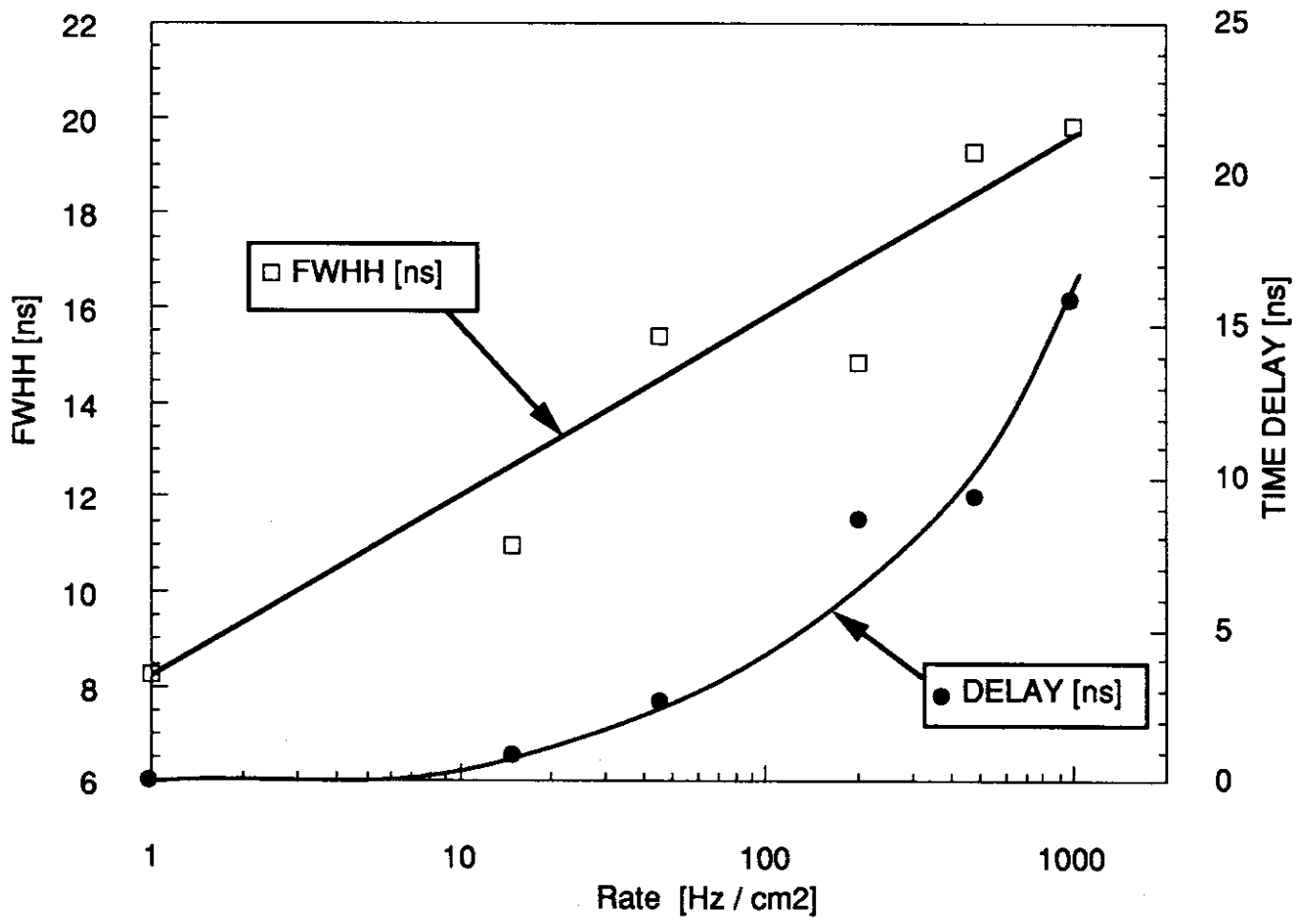

FIGURE 11



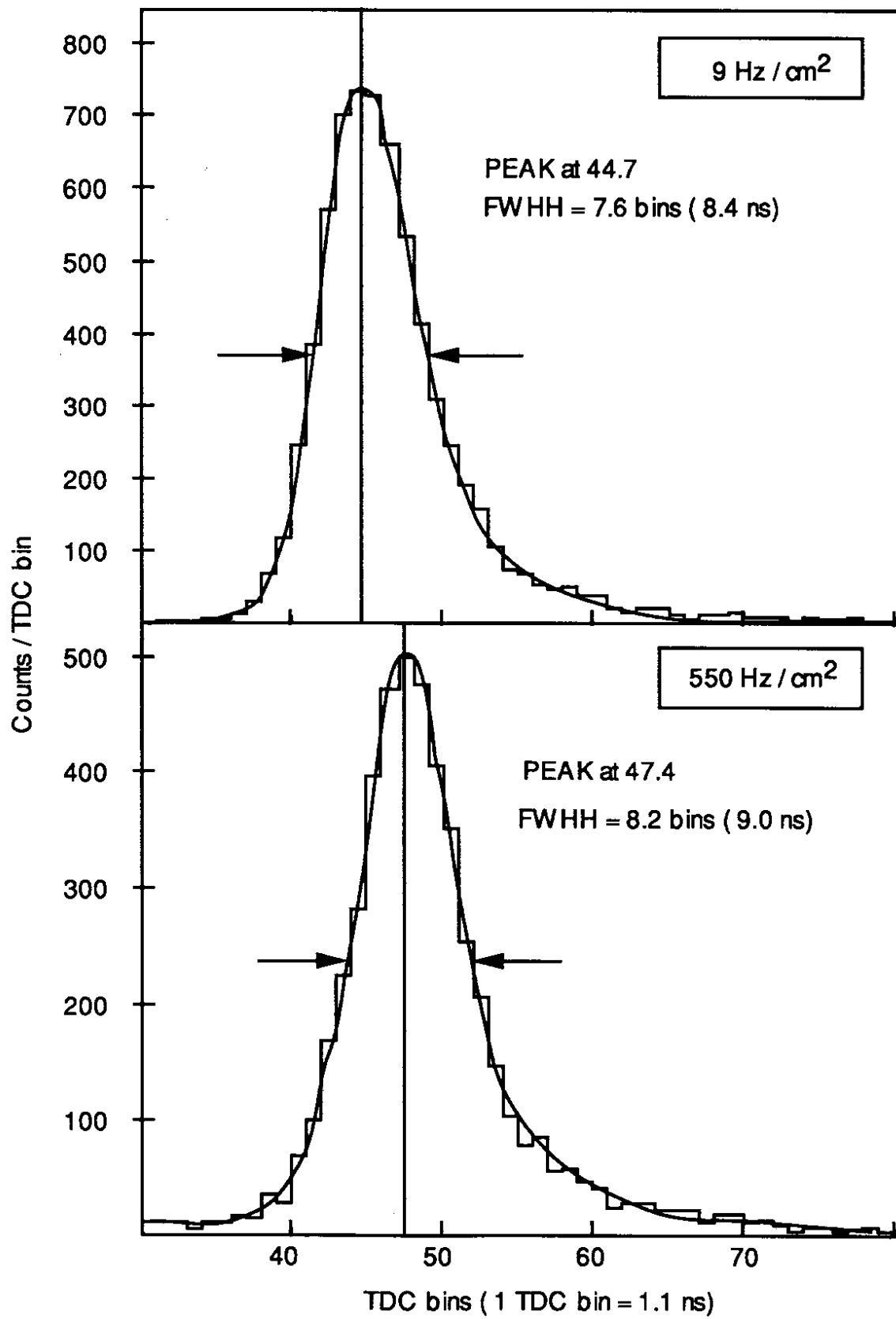

FIGURE 12