

The University of British Columbia

Faculty of Graduate Studies



PROGRAMME OF THE
FINAL ORAL EXAMINATION
FOR THE DEGREE OF
DOCTOR OF PHILOSOPHY

of

MOHAMED ATHER ALI

B. Sc. Presidency College, University of Madras, 1952

M. Sc. Zoology Laboratory, University of Madras, 1954

IN ROOM 187A, BIOLOGICAL SCIENCES BUILDING

TUESDAY, APRIL 29, 1958 at 2:30 p. m.

COMMITTEE IN CHARGE

DEAN G. M. SHRUM, *Chairman*

W. A. CLEMENS

W. S. HOAR

P. CONSTANTINIDES

C. C. LINDSEY

I. McT. COWAN

PING - TI HO

P. FORD

External Examiner: E. Horne Craigie
University of Toronto

A B S T R A C T

A histological study of the eyes of juvenile sockeye, coho, pink and chum salmon in fresh water shows that the cones, external nuclear and plexiform layers of the retinae of embryos and alevins are poorly differentiated and do not attain normal histological or physiological proportions until the emergence of fry from the gravel. From a histo-physiological study it is evident that only the emerged fry and older stages are capable of retinomotor responses and that these become more marked with age. Differences in rates of adaption are found among the species and stages. Generally, the pigment layer shows a latent period before contraction in dark. Sensitivity to light is independent of the complete light-adaption of the retinal pigment or visual cells, while full acuity of vision is dependent upon the complete light-adaption of cones. Threshold value of cones and rods are indicated by the feeding and schooling responses. At light intensities between the cone and rod thresholds the thicknesses of pigment and cone layers obey the Weber-Fechner Law. There is no diurnal rhythm in the positions of retinal pigment and cones of juvenile *Oncorhynchus* either under constant light or dark. Results are discussed in relation to the migratory, schooling and feeding behaviour. The rapid downstream migration of juvenile salmon during a relative short period in the night may be related to a semi-dark adapted state of the eye.

PUBLICATION

- Ali, M. A. Additions to the Sponge Fauna of Madras. J. Madras Univ. B., 26(2): 1956.
- Ali, M. A. Development of the Monaxonid Sponge, *Lissodendoryx similis* Thiele. J. Madras Univ. B., 26(3): 1957.
- Ali, M. A. and J. R. Brett. The Structure and Photomechanical Responses of the Pacific Salmon Retina. J. Fish.Res. Bd. Canada 15 (in press) 1958.

GRADUATE STUDIES

Field of Study: Zoology

History and General Principles of Biology	W. A. Clemens
Biology of Fishes	C. C. Lindsey
Environmental Physiology	W. S. Hoar
Fisheries Technology	H. L. A. Tarr and W. S. Hoar
Biological Methods and Procedures	Zoology Staff
Comparative Physiology	W. S. Hoar
Fisheries Biology	W. A. Clemens

Other Studies:

Biometry	V. C. Brink
Synoptic Oceanography	G. L. Pickard
Oceanography	W. A. Clemens
Special Advanced Oceanography	R. F. Scigel
Chemical Oceanography	M. Kirsch
Biological Oceanography	R. F. Scigel

THE OCULAR STRUCTURE, RETINOMOTOR AND PHOTO-BEHAVIOURAL
RESPONSES OF JUVENILE PACIFIC SALMON

by

MOHAMED ATHER ALI

B.Sc., Presidency College, University of Madras, 1952
M.Sc., Zoology Laboratory, University of Madras, 1954

A THESIS SUBMITTED IN PARTIAL FULFILMENT OF
THE REQUIREMENTS FOR THE DEGREE OF
DOCTOR OF PHILOSOPHY

in the Department
of
Zoology

We accept this thesis as conforming to the
required standard from candidates for the
degree of DOCTOR OF PHILOSOPHY

THE UNIVERSITY OF BRITISH COLUMBIA

April, 1958

ABSTRACT

A histological study of the eyes of juvenile sockeye, coho, pink and chum salmon in fresh water shows that the cones, external nuclear and plexiform layers of the embryos and alevins are poorly differentiated and do not attain normal histological or physiological proportions until the emergence of fry from the gravel. From a histo-physiological study it is evident that only the emerged fry and older stages are capable of retinomotor responses and that these become more marked with age. Differences in rates of adaptation are found among the species and stages. Generally, the pigment layer shows a latent period before contraction in dark. Sensitivity to light is independent of the complete light-adaptation of the retinal pigment or visual cells, while full acuity of vision is dependent upon the complete light-adaptation of cones. Threshold values of cones and rods are indicated by the feeding and schooling responses. At light intensities between the cone and rod thresholds the thicknesses of pigment and cone layers obey the Weber-Fechner Law. There is no diurnal rhythm in the positions of retinal pigment and cones of juvenile Oncorhynchus either under constant light or dark. Results are discussed in relation to the migratory, schooling and feeding behaviour. The rapid downstream migration of juvenile salmon during a relatively short period in the night may be related to a semi-dark-adapted state of the eye.

In presenting this thesis in partial fulfilment of the requirements for an advanced degree at the University of British Columbia, I agree that the Library shall make it freely available for reference and study. I further agree that permission for extensive copying of this thesis for scholarly purposes may be granted by the Head of my Department or by his representative. It is understood that copying or publication of this thesis for financial gain shall not be allowed without my written permission.

Department of Zoology

The University of British Columbia,
Vancouver 8, Canada.

Date April 16, 1958

ACKNOWLEDGEMENTS

Coming to Canada and doing post-graduate work at the University of British Columbia would have been a Herculean task had it not been for the kind offices of my friend and well wisher, Dr. E.A. Forsey, Director of Research, Canadian Labour Congress, and I wish to take this opportunity to express my deep gratitude to him for helping me to come to Canada, the interest shown and help given on several occasions.

My thanks are due the World University Service of Canada for the award of a bursary during 1954-55.

To my teachers and philosophers, Dr. W.A. Clemens, F.R.S.C., and Dr. W.S. Hoar, F.R.S.C., I owe my most humble thanks for the interest shown in me and my work since the day of my arrival in Vancouver and for the unfailing guidance, advice and encouragement given so ungrudgingly throughout the last four years.

I was first introduced to the study of vision by Dr. J.R. Brett, Senior Scientist, Fisheries Research Board of Canada, Nanaimo, B.C., while employed there during the summers of 1955 and 1956. I have found this study a rich and rewarding experience and am thankful to him for introducing me to it.

To Dr. C.C. Lindsey, I am thankful for many stimulating discussions and for the suggestions and criticisms that improved the experiments and the thesis. The advice given by Dr. P. Constantinides and Dr. P. Ford, F.Z.S., during the course of this work is acknowledged.

This research was carried out in the Department of Zoology and the Institute of Fisheries and I wish to acknowledge the encouragement given and facilities provided by Dr. I. McT. Cowan, F.R.S.C., Head of the Department of Zoology

and Dr. P. Larkin, Director of the Institute of Fisheries. The assistance given by my colleagues is also gratefully acknowledged.

Mr. R.J.H. Beverton of the Fisheries Laboratory, Lowestoft, while here on an H.R. MacMillan Visiting Lectureship, provided valuable advice on statistical methods and analyses for which I am thankful.

Prof. Dr. G. von Studnitz, Director of the Natural History Museum, Lubeck, W. Germany, wrote and advised me on several aspects of my problem and also brought my attention to the publications of some German workers and I wish to acknowledge this thankfully.

The keen personal interest taken by Thomas Killam in the execution of the attractive diagrams that adorn this thesis is gratefully acknowledged.

To Mr. and Mrs. Hermann Schlagintweit and Miss Sibylle Schlagintweit, I owe my thanks for the assistance given and particularly for improving the nodding acquaintance I had with the German language to a more familiar one. Without this, deciphering and understanding the vast literature in German, so essential in an investigation concerning visual physiology, would have been a formidable task.

This research was supported by a grant from the Fraser River Hydro and Fisheries Advisory Committee of the University of British Columbia.

RESPECTFULLY DEDICATED

TO

MY PARENTS

TABLE OF CONTENTS

I	INTRODUCTION.....	1
II	MATERIAL AND METHODS.....	3
	A. Material.....	3
	B. Experimental methods.....	3
	1. General.....	3
	2. Rates of adaptation.....	5
	a. As seen by photomechanical responses of the retina.....	5
	b. Schooling times.....	5
	c. Feeding rates.....	7
	3. Retinal and behavioural responses to light intensities.....	8
	a. Retinal photomechanical responses to light intensities.....	8
	b. Feeding rates under different light intensities.....	8
	c. Observations on intensities at which schools dispersed.....	9
	4. Photomechanical responses under constant light or dark.....	9
	5. Histology.....	10
	a. Technique for routine study.....	10
	b. Modified Golgi technique.....	10
	i. Fixation.....	10
	ii. Silver impregnation.....	11
	iii. Dehydration.....	11
	iv. Celloidin imbedding.....	11
	v. Paraffin imbedding.....	11
	vi. Sectioning.....	12
	vii. Mounting.....	12
	6. Measurements of retinal pigment and cone layers.....	12
III	RESULTS.....	14
	A. Structure of <u>Oncorhynchus</u> eye.....	14

1. General shape	14
2. Vertical lids.....	14
3. Cornea.....	14
4. Sclera.....	16
5. Annular ligament.....	16
6. Iris.....	16
7. Lens	17
8. Intra-ocular fluids.....	18
9. Chorioid.....	18
10. Falciform process.....	19
11. Retina.....	21
B. Differences among stages.....	27
C. State of a typical light-adapted retina.....	29
D. State of a typical dark-adapted retina.....	29
IV EXPERIMENTAL RESULTS.....	30
A. Light-adaptation.....	30
1. The process of retinal light-adaptation....	30
2. Embryos.....	31
3. Alevins (Hatching stage).....	31
4. Emerged fry.....	36
a. Retinal response.....	36
b. Schooling rates.....	40
c. Feeding rates.....	41
5. Late fry.....	41
a. Retinal response.....	41
b. Schooling rates.....	47
c. Feeding rates.....	49

6.	Smolts.....	49
a.	Retinal response.....	49
b.	Schooling rates.....	49
c.	Feeding rates.....	52
B.	Dark-adaptation.....	52
1.	The process of dark-adaptation.....	52
2.	Embryos.....	56
3.	Alevins (Hatching stage).....	56
4.	Emerged fry (Post-yolk sac stage).....	59
5.	Late fry.....	59
6.	Smolts.....	60
C.	Retinomotor and behavioural responses to different light intensities.....	64
1.	Alevins.....	69
2.	Late fry.....	72
3.	Smolts.....	75
D.	State of the retinal pigment and cone layers under constant light or dark.....	78
V	DISCUSSION.....	85
A.	Structure of the <u>Oncorhynchus</u> eye.....	85
1.	Iris.....	85
2.	Supplementary nutritive device.....	85
3.	Chorioid gland.....	86
4.	Twin cones.....	86
B.	Correlation between the arhythmic mode of life of <u>Oncorhynchus</u> and the structure of its retina.....	86

C.	Retinomotor responses.....	87
1.	Phylogenetic occurrence.....	87
2.	Ontogeny of retinomotor response in <u>Oncorhynchus</u>	88
3.	Interspecific comparison of retinomotor responses of the species and stages of <u>Oncorhynchus</u>	89
D.	Significance of retinomotor response in the life of juvenile <u>Oncorhynchus</u>	89
1.	Precedence of light sensitivity to retinomotor responses.....	89
2.	Migratory behaviour.....	90
3.	Schooling.....	93
4.	Feeding.....	93
VI	CONCLUSIONS.....	95
VII	LITERATURE CITED.....	97

TABLES

I.	Details regarding the fish used in the present investigation.....	4
II.	Details of the rates of light-adaptation in alevins.....	34
III.	Particulars concerning the rates of light-adaptation of emerged fry.....	37
IV.	Details of rates of light-adaptation of late fry....	44
V.	Particulars regarding the rates of light-adaptation of the smolts.....	51
VI.	Summarising results of previous investigations concerning rates of dark-adaptation of various species of fish.....	54
VII.	Details regarding the rates of dark-adaptation of the alevins.....	58
VIII.	Details regarding the rates of dark-adaptation of the emerged fry.....	60
IX.	Particulars concerning the rates of dark-adaptation of the late fry.....	62
X.	Particulars regarding the rates of dark-adaptation of the smolts.....	65
XI.	Summarising the rates of dark-adaptation of various fish used in previous investigations.....	67
XII.	Details of the state of the eye of the alevins under different light intensities.....	71
XIII.	The state of the eye, feeding and schooling under different light intensities in the case of late fry.....	74
XIV.	The state of the eye and feeding of smolts under different light intensities.....	76
XV.	Summary of results of previous investigations concerning the state of the eye and acuity of fish of various species.....	80

ILLUSTRATIONS

1.	Diagram showing the tanks used in the experiments.....	6
2.	Photomicrograph of a vertical section of the eye of <u>Oncorhynchus</u>	15
3.	Photomicrograph showing the falciform process in emerged fry.....	20
4.	Photomicrograph of retina and diagram of the neurological arrangement therein.....	22
5.	A. Diagram of retinal pigment, cones and rods in the light and dark-adapted states.....	24
	B. Diagram showing the arrangement of cones in the regions of the fundus and ora serrata.....	24
6.	Graph showing the rate of expansion of the pigment and contraction of cones on exposure to light in the various stages of sockeye studied.....	32
7.	Graph showing the rate of expansion of pigment and contraction of cones on exposure to light in the various stages of coho.....	33
8.	Graph showing the rate of expansion of pigment and contractions of cones on exposure to light in the various stages of pink.....	35
9.	Graph showing the rate of expansion of pigment and contraction of cones on exposure to light in the various stages of chum.....	38
10.	Graph showing the schooling rate of dark-adapted emerged and late fry and smolts on exposure to light..	39
11.	Graph showing the feeding rates of conditioned dark-adapted emerged and late fry and smolts on exposure to light.....	42
12.	Photomicrographs of "light" and "dark"-adapted retinae of late embryos.....	43
13.	Photomicrographs of light and dark-adapted retinae of alevins.....	45
14.	Photomicrographs of light and dark-adapted retinae of emerged fry.....	46
15.	Photomicrographs of light and dark-adapted retinae of late fry.....	48

16.	Photomicrographs of light and dark-adapted retinae of smolts.....	50
17.	Histogram showing the time for light-adaptation of pigment and cones of emerged fry, late fry and smolts	53
18.	Rate of contraction of the pigment and expansion of the cones of the various stages of sockeye.....	55
19.	Rate of contraction of pigment and expansion of cones in dark of the various stages of coho.....	57
20.	Rate of contraction of the pigment and expansion of the cones of the various stages of pink.....	61
21.	Rate of contraction of the pigment and expansion of the cones in dark of the various stages of chum.....	63
22.	Histogram showing the times taken by pigment and cones of emerged fry, late fry and smolts to dark-adapt.....	66
23.	Graph showing the thicknesses of the pigment and cone layers of sockeye and chum alevins under various light intensities.....	70
24.	Graph showing the thicknesses of pigment and cone layers and feeding rates of late fry belonging to the different species.....	73
25.	Graph showing the pigment and cone thicknesses and feeding rates of smolts belonging to different species under various light intensities.....	77
26.	Histogram showing the cone thresholds of alevins, late fry and smolts of the various species studied...	79
27.	Diagram summarising some results obtained in the present investigation together with some other responses of Pacific salmon to various natural conditions are also given.....	81
28.	Graph showing the thicknesses of pigment and cone layers of late chum fry under constant light and dark at intervals of 3 hours for 96 hours.....	83

I. INTRODUCTION

Light plays an important role in the life of animals. Phenomena such as feeding, sexual maturity and migration are governed wholly or partly by light. The chief photoreceptors of most vertebrates are their eyes. For obvious reasons, the human eye was the first to be studied and seems to have kindled the interest of workers as early as 1,000 B.C. (Sasruta, c. 1,000 B.C.). However, detailed investigations yielding results similar to those available at present were not made until the ninth century A.D. (Hunain ibn Ishak, 806-877; Ali ibn Isa, 940-1010). Since then, much work on the vertebrate as well as the invertebrate eye has been carried out, especially during the last one hundred years, and excellent books dealing with the structure and physiology of the eye with extensive bibliographies are available (Polyak, 1941, 1957; Walls, 1942; Rochon-Duvigneaud, 1943, 1958; Detwiler, 1943; Granit, 1947, 1955; von Studnitz, 1952; von Buddenbrock, 1952).

The mechanism of accommodation to distant or near vision varies from one vertebrate group to another and often within the same class (Walls, 1942, pp. 272-3). The various classes of vertebrates also show differences in the way they adapt their eyes for photopic or scotopic vision. This is accomplished either by photomechanical changes involving the dilatation and contraction of the iris or movement of the retinal pigment and visual cells (Walls, 1942; Rochon-Duvigneaud, 1943, 1958; von Studnitz, 1952. Teleosts, with the exception of the eel (von Studnitz, 1933), stargazers and flatfish (Young, 1931, 1933), light and dark-adapt solely by the migration of the retinal pigment and visual cells. The eel has a contractile iris in addition. The stargazers and flatfish light and dark-adapt by the contraction and dilatation respectively of their iris and it is not known whether their retinae are capable of undergoing photomechanical responses. The photomechanical changes in the teleost eye, in response to light or dark are pronounced, equalled only by those seen in the eyes of birds

(Detwiler, 1943). Several investigations have been carried out to demonstrate the positional changes undergone by the retinal pigment and visual cells of fishes in light and dark (Garten, 1907; Arey, 1915, 1928; Parker, 1932; Detwiler, 1943; von Studnitz, 1952).

In a preliminary study of the Oncorhynchus eye no differences were found in the retinae of the various species (Ali, 1956; Ali and Brett, 1958). This is perhaps surprising since differences have been observed among the species of Oncorhynchus in their reactions to light (Hoar, 1951, 1953, 1956, 1958; Hoar et al, 1957). It seemed possible that a more detailed study of the eye and the ontogeny of photomechanical and behavioural responses of the different species might reveal differences not detected in the initial study. If differences are present these might at least partly explain the somewhat different responses of the various species to light during their downstream migration. This study was based on the assumption that such a detailed comparative histophysiological examination of the eye would contribute further to an understanding of the mechanisms of downstream migration of salmon.

II. MATERIAL AND METHODS

A. Material

All the experiments were carried out in 1957. Table I shows the species and stages of salmon used and gives some particulars regarding them. All the fish, except sockeye and coho smolts were from the hatchery, the Department of Zoology, University of British Columbia.

Maximum light intensities at the surface of the water in the fish troughs were 1.5 to 2.5 ft-c., in January and July respectively. Diurnal light period varied with the season of the year. The water temperature ranged from 7°C to 13°C.

The fish were fed twice daily on a mixture of Clark's dry food*, canned salmon, Pablum**, cod liver oil and yeast extract. The cod liver oil supplement was adequate to satisfy Vitamin A requirements essential for the proper functioning of the visual mechanism (Detwiler, 1943; Kampa, 1953).

B. Experimental methods

1. General. Experiments were carried out in a light proof room. Two photometers were used for measuring light intensities. They were a Photovolt Model 200 Photometer and a Photovolt Model 520-M Electronic Photometer. The former was used to measure light intensities above 10⁻¹ ft-c. and the latter to measure the lower intensities. The model 520-M was used with filters (Eastman Kodak wratten filters No. 81-EF; CC-10-M; 81-C) to produce a curve with equal spectral response to light of wavelengths 3,000 Å to 7,000 Å. The desired light intensities were created with bulbs of similar spectral ranges. Foot-candle (ft-c.) is the unit of light measurement employed throughout. One ft-c., is equal to 10.764 Lux (Metre-candles).

* Obtained through the courtesy of Mr. J.R. Clark of Salt Lake City, Utah, U.S.A.

** Meade Johnson. Prepared mixed cereal.

TABLE I - Particulars of the material used in this investigation.

Species and Stage	Length in c.m.	Experiments in which fish were used						
		Rate of Adaptation			Adaptation to L. Intensity			
		Histo- logical	Schooling	Feeding	Histo- logical	School Dispersion	Feeding	Diurnal Rhythm Expt.
<u>Sockeye</u>								
Embryo	0.50*	+						
Alevin	2.00	+			+			+
Emerged fry	2.75	+	+	+				
Late fry	3.50	+	+	+	+	+	+	+
Smolt	6.80	+		+	+		+	+
<u>Coho</u>								
Embryo	0.80*	+						
Alevin	2.30	+						
Emerged fry	3.70	+	+	+				
Late fry	3.90	+	+	+	+	+	+	+
Smolt	7.10	+		+	+		+	
<u>Pink</u>								
Embryo	0.80*	+						
Alevin	2.40	+						
Emerged fry	3.30	+	+	+				
Late fry	3.40	+	+	+	+	+	+	
<u>Chum</u>								
Embryo	.80*	+						
Alevin	2.40	+			+			+
Emerged fry	3.30	+	+	+				
Late fry	3.90	+	+	+	+	+	+	+

* The measurements given for embryos are the diameters of eggs.

2. Rates of Adaptation

a. As seen by photo-mechanical responses of the retina

In these experiments animals were sampled at intervals following sudden exposure to bright light after a period in darkness or reverse situation. The experiments were carried out using a rectangular galvanised iron trough 137 cm. long, 38 cm. wide and 30 cm. high, painted black on the inside. Water circulation was maintained during the experiment. The trough was illuminated (400 ft-c.) by two Sylvania Reflector flood lamps, fixed on opposite ends of the tank. Diagonal wire frames were placed at the ends of the tank to make sure all the fish were in the same intensity of light, that is, that none was able to retreat to the less bright corners. The arrangement is shown in Figure 1.

All the experiments were carried out during the forenoon. Possible variation caused by diurnal rhythm or similar factors was thus minimised. In the light adaptation experiments fish were left in total darkness in the experimental tank overnight. At the commencement of the experiment, the first samples were taken in total darkness (zero minutes) and then the lights were turned on and the samples taken after the following times (in minutes): 1, 2, 3, 4, 5, 10, 15, 20, 25, 30, 35, 40, 45, 50, 55, 60 and 70.

In the dark adaptation experiments the fish were left in the illuminated tank (400ft-c.) overnight, the first sample was taken from the illuminated tank (zero minutes); the lights were turned off and samples taken in total darkness at the same intervals as in the case of light adaptation.

The frequency of samples was based on earlier work by Ali and Brett (1958) where dark adaptation of sockeye was found to be complete in 50 minutes.

b. Schooling times

The same tank was used. Only emerged and late fry were studied. A group of 50 fish were left in the tank in darkness overnight. The lights were turned on the next morning

Fig. 1. The tanks used in the various experiments
(see text).

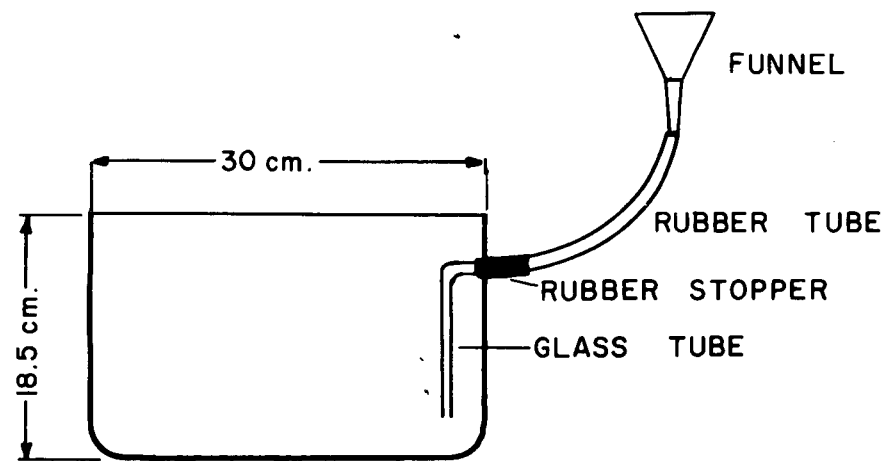
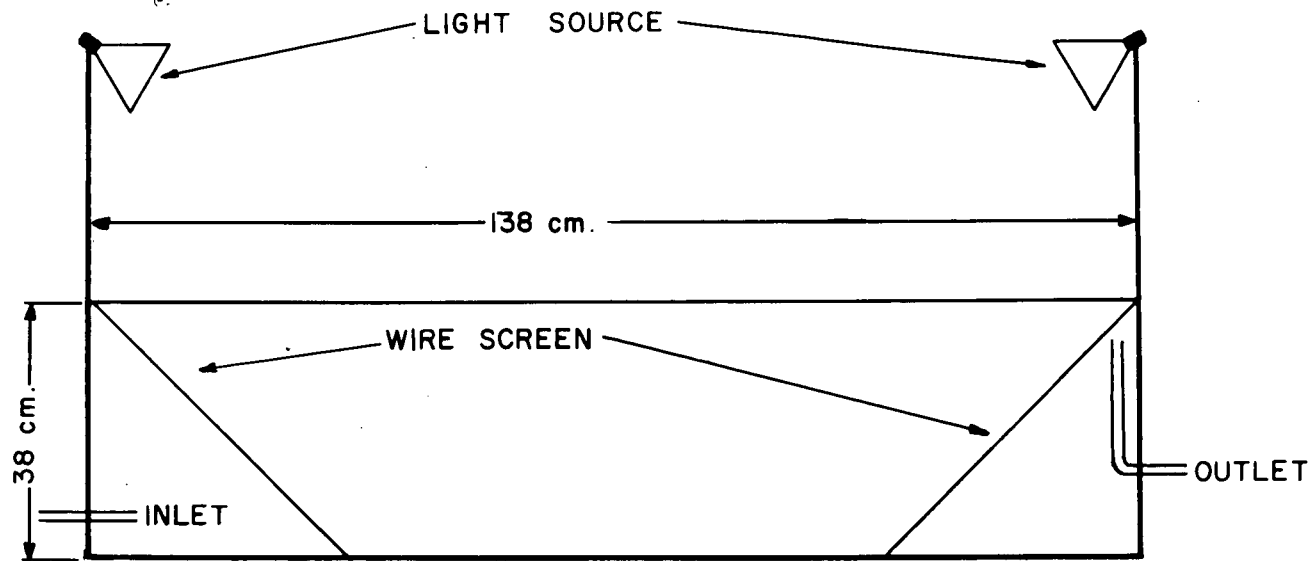

and the number of schooled fish recorded at five minute intervals. If more than two fish were swimming in the same direction, at the same speed and in regular formation, this was considered a school. Occasionally two schools were seen in the same tank. In these cases the total number of fish in both schools was taken as the number of fish schooled. Observations were continued until most of the fish schooled or till the strength of the school reached a maximum and the number stayed the same for over five minutes.

Some of the recently emerged fry did not form schools within a day or two after emerging. In this case 50 fish were first transferred to another tank under brighter light (400 ft-c.), where they schooled readily. They were then used in the experiment after they had had schooling experience.

c. Feeding rates

Fish (six from each group) were first conditioned for at least a week to feed on Daphnia. The food was presented each morning in association with a vibratory stimulus given by gently tapping the side of the aquarium with a rod. All learned quickly and after five or seven days of training were able to feed on about 18 to 20 Daphnia per minute.

Six aquaria (30 cm. long, 24 cm. wide and 24 cm. high) were arranged in a large trough of running water with one conditioned fish in each. Each tank had an opening on the side through which a glass tube, inserted through a rubber stopper, was passed. This glass tube reached almost the bottom of the aquarium. The outer end of the glass tube was attached to a rubber tube with a funnel (Fig. 1). This arrangement was resorted to so that the fish could be fed without too much disturbance. The next morning the lights were turned on (400 ft-c.) and 100 Daphnia were poured into the aquarium through the funnel after giving the vibratory stimulus. After five minutes the fish was quickly removed from the tank and another 100 Daphnia poured into the next aquarium in the same way as in the case of the first one after giving the stimulus; after five minutes this was also removed and the same procedure repeated in all the remaining aquaria. After the sixth tank the water from each aquarium was poured out through a net

and the remaining number of Daphnia in each tank counted. Control experiments without fish in the aquarium showed that the experimental procedure was accurate and no Daphnia were lost during the process of pouring through the funnel, capturing and counting.

3. Retinal and Behavioural responses to light intensities

In these experiments the desired light intensities were created by reflecting the light from the white ceiling. The lower light intensities were obtained with weaker bulbs and in the case of the lowest light intensity used (10^{-5} ft-c.), a black wooden box with an aperture diaphragm and with a G-E 7.5 watt bulb was used. The following were the light intensities created; 10^2 , 10^1 , 10^0 , 10^{-1} , 10^{-2} , 10^{-3} , 10^{-4} , 10^{-5} ft-c., and almost total darkness. Light intensities were read at different areas of the large trough and glass aquaria (30 cm. long, 24 cm. wide and 24 cm. high) set up in the areas where the light readings were similar.

a. Retinal photomechanical responses to light intensities

The fish were left in the light intensity at which they were to be fixed for an hour and a half before they were killed. This time was more than sufficient for the fish to adapt to that particular intensity.

With sockeye and chum alevins one group each was kept under constant light and another batch of each in constant dark for three days before exposing them to different light intensities. This was done to determine whether previous experience had any effect on their reactions to different light intensities. Since no difference was observed this procedure was discontinued in subsequent experiments and fish from the hatchery were directly transferred to the intensity under which they were to be fixed.

b. Feeding rates under different light intensities

Three fish from each group were conditioned to feed on Daphnia as described above. All six types of salmon were

studied at the same time. The desired intensity of light was set up in the morning and one conditioned fish from each group put in a separate aquarium (30 cm. long, 24 cm. wide and 24 cm. high) and left under the light intensity for an hour and a half after which the Daphnia were fed in the usual manner. After five minutes the fish was taken out and the remainder of Daphnia counted. The three fish were thus studied in succession. By adopting this procedure the whole series was completed in nine days. The remainder of the 100 Daphnia were offered to the fish after the experiment to ensure that all fish got the same amount of food every day.

c. Observations on intensities at which schools dispersed

Only the late fry were used in this experiment. The experimental arrangement was the same as above. About ten fish were put in the aquarium and left in it for an hour and a half under the light intensity at which they were to be observed to see whether the school was intact or dispersed. The writer was able to observe this without any difficulty after adapting himself (10-15 minutes) to the intensity in question. Under 10^{-5} ft-c., observations were made by suddenly switching on the light and noting whether the school had broken up. Even under the intensities where the animals had formed a school, sudden illumination broke up the school, but it was possible, immediately after turning on the light (one to two seconds) to notice the intact school and then its dispersal. In the event where no school was existing, it was possible immediately on turning on the light to see the fish scattered all over the aquarium, some even settled on the bottom.

4. Photomechanical responses under constant light or dark

These experiments to test for diurnal rhythm in the positions of the retinal pigment and visual cells in constant light or dark were carried out using the galvanised iron tank described above (Fig. 1). All the experiments were commenced at noon and ended 96 hours later. Animals to be sampled were left in the tank in light (400 ft-c.) or in dark and sampled every three hours.

5. Histology

a. Technique for routine study

Bouin's fixative was used throughout. The whole animal was killed by dropping directly into separate jars of Bouin's fixative. This method was resorted to after comparing the retinae of fish fixed by three different methods viz., (i) dropping the animal directly in Bouin's (ii) beheading and fixing only the head and (iii) anaesthetising first with chloretone and then enucleating the eyes and fixing them. It was found that there was no difference among the retinae fixed by these methods. Direct fixation was less time consuming and also the length of the fish and diameter of the eye could be measured later.

After a day in the fixative, the fish was measured and the eyes (in the smolts) or the whole head (embryos, alevins and fry) excised and left in the fixative for another day. The lenses of the smolts and late fry were removed. The eyes and the heads were kept in 70% alcohol for one or two days, after which they were dehydrated in 90% absolute alcohol, cleared in xylene and embedded in paraffin (Fisher's tissuemat; M.P. 52°C).

Sections were cut at eight microns, stained with Harris' haematoxylin, counterstained with eosin and mounted in Canada balsam.

b. Modified Golgi technique

To study the neurological arrangement of the retina, Golgi's silver impregnation technique, modified as follows by the author, was used.

i. Fixation

The fixative was injected into the eye of the anaesthetised fish. Subsequently, the enucleated eye was punctured at the sclero-corneal junction and dropped into the fixative. The fixative consisted of the following:

4 parts of 3% potassium dichromate solution and

1 part of a 1% solution of osmium tetroxide (osmic acid).

Soon after dropping the eye in the fixative more fixative was injected and this process was repeated until the eye was hard

enough for the cornea to be removed. When the eye was hard enough, the cornea and the lens were removed. The rest of the eye was left undisturbed for seven days at 40°C.

ii. Silver impregnation

After the period of fixation, the eye was taken out of the fixative and the fixative removed from it using absorbent paper. Then it was placed in a 1% silver nitrate solution. This solution was changed every seven minutes, twice, after which the eye was left in it for two days. After this period, the eye was rinsed in fresh silver nitrate solution, so as to remove the precipitation particles. Later, the eye was left in running tap water for a day to wash the osmium and then transferred to distilled water which was changed twice.

iii. Dehydration

Subsequently, the eye was dehydrated in 70%, 95% and 100% alcohols for half an hour in each strength. After dehydration it was left in a mixture of one part of acetone and three parts of absolute alcohol for one hour at 60°C. Cupric sulphate was added to the alcohols a day or two in advance of use. After this treatment, the eye was washed in several changes of absolute alcohol to remove traces of acetone.

iv. Celloidin imbedding

One day each in the following:

1:1 ether and alcohol mixture

2, 4, 8 and 16% celloidin

After a day in 16% celloidin the eye was blocked and left for one hour in chloroform followed by another hour in 70% alcohol.

v. Paraffin imbedding

Two changes of one and one half hours in xylene were given. When the eye was in xylene, the container was transferred to a cold oven set at 52°C and the heat turned on. In this way the specimen was gradually warmed. When the temperature in the oven reached 52°C the eye was transferred to paraffin (M.P. 52°C) and given two changes of 45 minutes each. After this the specimen was blocked, without using cold water to harden the paraffin.

vi. Sectioning

Sections were cut at 60 microns. Celloidin sections were placed on slides, blotted and covered with 1% celloidin and dehydrated in 75 and 95% alcohol and cleared in 1:3 mixture of carbol and xylene and then left in pure xylene. Afterwards the sections were covered with thick Canada balsam.

vii. Mounting

Paraffin sections were also cut at 60 microns, placed on slides and the usual technique for mounting followed. In the case of both celloidin as well as paraffin sections, no cover slips were placed until the balsam on the slides hardened in an oven set at 50°C for two days. After the balsam hardened, coverslips were placed with weights on top of them and left for three days before examining them under the microscope.

6. Measurements of retinal pigment and cone layers

In all the eyes, thicknesses of the retina, retinal pigment and cone layers were measured, with a calibrated ocular micrometer, in the dorsal region between the ora serrata and the fundus. The pigment layer was measured as the distance between the inner border of the chorioid and the tips of the pigment projections which varied only four microns. The cone layer was measured from the external limiting membrane to the tips of the cone outer segments, since only the myoid which is outside the external limiting membrane undergoes elongation and contraction.

In this paper thicknesses are compared directly. This was done because it was observed that the cone and pigment layers do not vary in thickness proportionately to the thickness of the retina. After examining nearly 9,000 eyes the author concludes that in a group of fish of the same age and size, the thicknesses of the pigment and cone layers vary at random. Unless a large number of animals of the same age and size group are killed under exactly identical conditions and their retinae and retinal layers measured and some sort of relationship among them established statistically, it is very difficult to say with any amount of certainty whether the retinal layers vary in

proportion to the retinal thickness, size or weight of the animal or the diameter of its head or eye ball. True, the retina and consequently the various retinal layers are thicker in an older, larger animal but the argument given above applies only to the animals in the same age and size group. In the present investigation, in each experiment only animals of same age were used.

III. RESULTS

A. Structure of the Oncorhynchus eye (Figs. 2, 3, 5)

1. General shape

The eye of the juvenile Pacific salmon is large and well developed. The eye ball is flattened anteriorly and held in position in the eye socket by six oculomotor muscles (external rectus, internal rectus, superior rectus, inferior rectus, superior oblique and inferior oblique). The eyes are capable of a small amount of movement, which is brought about and coordinated by these oculomotor muscles.

2. Vertical lids

The Pacific salmon possesses vertical lids which cover the circumocular sulcus and eliminate distortive eddies in the slipstream alongside the eyes. The vertical lids, which are muscular, are attached to the orbital bones by special ligaments. The lid complex of the Pacific salmon is composed of a crescentic and narrow posterior lid overlapping approximately two thirds of the eye circumference with a triangular and broad anterior fold. The anterior fold is depressed below the head surface and does not arise from the extreme margin of the circumocular sulcus but seems to arise as a separate conjunctival fold arising from beneath the margin on the anterior side of the membranous orbit. Since the bony orbit is not complete anteriorly, the drawing of anterior sulcal margin forward will allow a wider range of forward and binocular vision. The anterior lid fold is the "false nictitating membrane".

3. Cornea

The anterior, exposed, flattened and transparent corneal surface is smooth. This may be attributed to the fact that the Pacific salmon is a fast swimmer. The corneal tissue is avascular and might be nourished by the intra-ocular fluid. Part of the required oxygen might be absorbed from the surrounding water. The outline of the cornea is circular and its centre is shifted towards the nasal side as in most fast swimming fish. The outermost surface of the cornea is made of transparent

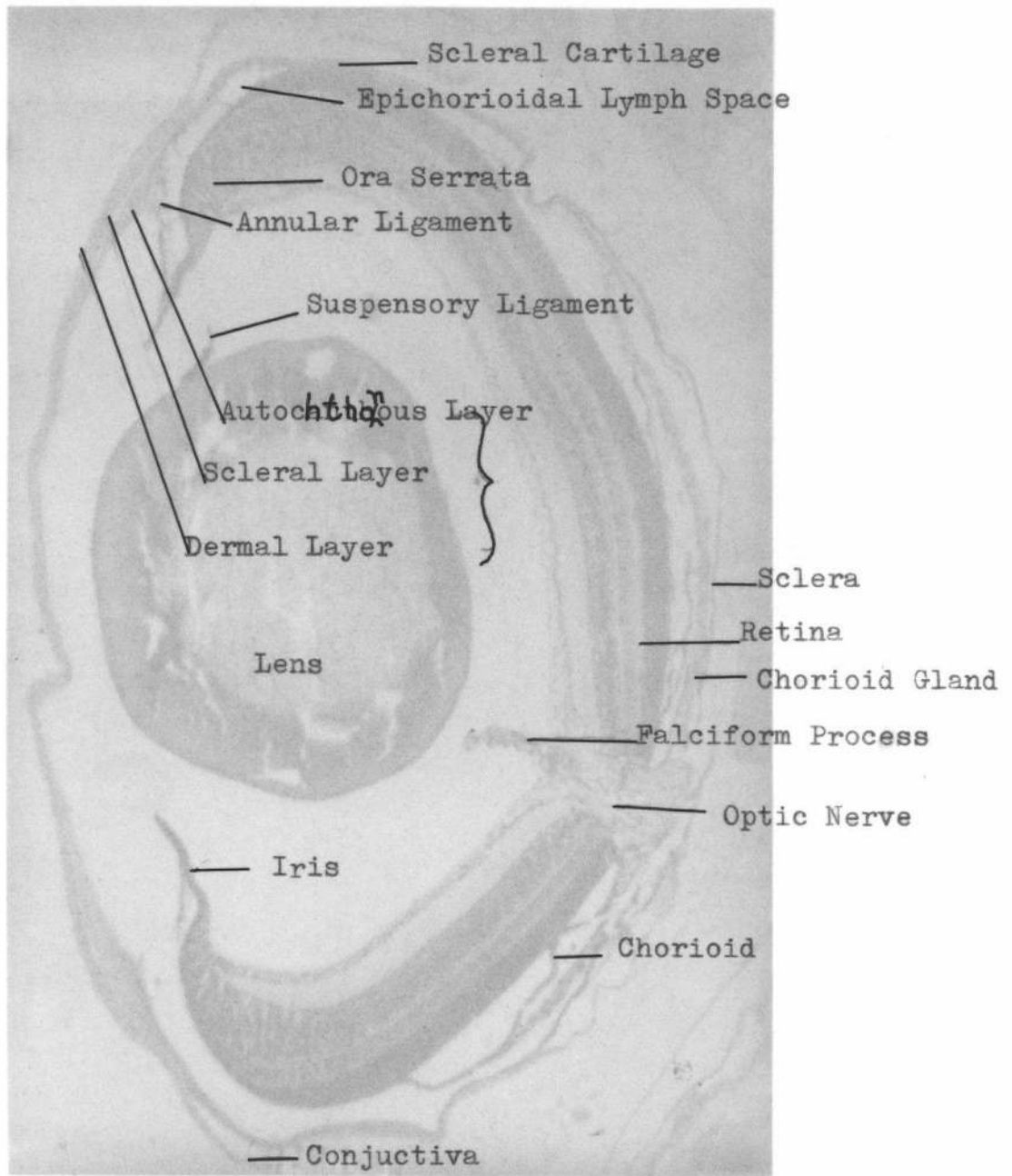
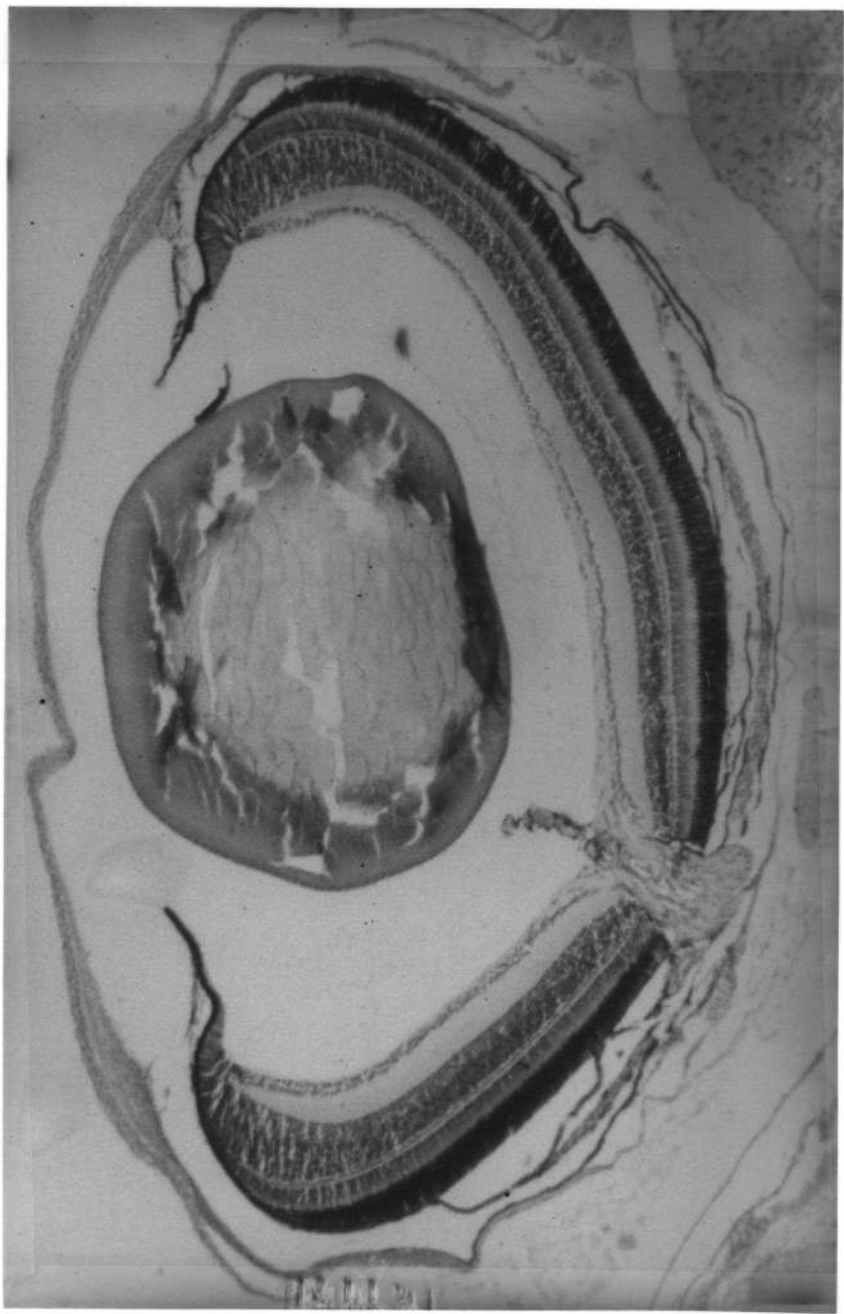

Figure 2. Photomicrograph of a vertical section of an Oncorhynchus eye. x90.



dermal layer which is a continuation of the head skin. This layer is two cells thick and is the thickest layer of the corneal complex. The next two layers, the scleral and autocanthous, are much thinner and are composed of numbers of fibres. The scleral layer remains thin throughout and joins the scleral cartilage at the region where the eye socket commences. The autocanthous layer, on the other hand, becomes broader at the points away from the anterior-most surface of the eye and assumes a triangular shape. A little posteriorly, it becomes narrow again and joins the chorioid at the corneal-scleral junction. In this locality an epichorioidal lymph space is present between the sclera and the chorioid.

4. Sclera

The sclera forms two thirds of the outer covering of the eye and is cup-shaped. It is tenacious and opaque and is enclosed in the eye socket. This tough envelope is essential to maintain the shape of the eye and to cope with changes in pressure, both intra-ocular and external. The scleral cartilage in the Pacific salmon is in the form of a broad ring encircling the eyeball at the region slightly posterior to the corneal-scleral junction. This cartilage is thin, one cell deep. At the posterior one-thirds of the eye where the sclera has no cartilage, it consists of a tough tenacious, fibrous layer. The sclera is slightly silvery due to the presence of guanine crystals.

5. Annular ligament

A very prominent annular ligament is present in the Pacific salmon eye and may rightly be called the connexion between the iris and the cornea. It merges with the chorioid layer at the corneal-scleral junction. The annular ligament covers most of the iris except the central most edge. It does have a secretory appearance, and as Walls (1942) suggested, is probably the source of the aqueous humour.

6. Iris

The iris is well developed and prominent. The pigment of the iris is a continuation of the epithelial pigment layer of the retina. The iris pigment layer is different from

the retinal pigment layer in that the former is found always in the form of a thin strip and neither expands on illumination nor contracts in dark. It is made up of small spherical or ellipsoid granules and contains no needle-shaped granules which the retinal pigment does, in addition to the spherical and ellipsoid granules near the nucleus. The iris pigment joins the retinal pigment a little posterior to the corneal-scleral junction and the ora serrata. Another difference between the iris and the retinal pigment cells is that the former do not have finger like processes distally, which the latter do. The iris, as such, is an extension of the retina beyond the ora serrata. The region where the retina becomes the iris is interesting. The visual cell layers do not extend beyond the corneal-scleral junction but the external nuclear layer and the other retinal layers extend a little farther anteriorly. However, the iris tissue has its beginnings from near the corneal-scleral junction and gets broader, almost spindle-shaped anteriorly, tapering into a long columnar epithelium like tissue at the central region which is in contact with the lens. Only at the very tip of the iris is pigment present on both the anterior as well as the posterior surfaces.

The iris of the Pacific salmon is not capable of photomechanical changes. When sockeye and chum fry were left in dark individually, in small, narrow tanks or in irrigated glass tubes and then suddenly exposed to bright light, no contraction of the pupil was observed. Measurements of the iris of intact as well as enucleated eyes, exposed to diffuse light of low intensity as well as bright light (400 ft-c.) did not show any changes in diameter (2 mm.).

7. Lens

The spherical lens consists of concentrically formed layers and is an isolated transparent body of cells. The anterior half of the lens has, as its outer layer (almost like a covering) an epidermal layer which is not dissimilar to the dermal layer of the cornea but only one cell deep. The lens of the Pacific salmon exhibits two different staining properties. The peripheral regions stain with haematoxylin and the core takes

only eosin. The structure seems more concentric in the centre than on the periphery and the concentric rings are further subdivided, especially in the peripheral regions, into cross striations.

The lens is held in position by a suspensory ligament dorsally and a retractor lentis ventrally. The suspensory ligament arises directly from the region of the ora serrata while the retractor lentis originates from the falciform process which runs more or less horizontal to the embryonic central fissure.

8. Intra-ocular fluids

The small amount of aqueous humour in the anterior chamber is watery and saline*. The posterior chamber is filled with gelatinous vitreous humour. The vitreous humour, in addition to the suspensory ligament prevents the lens from slipping into the posterior chamber. In addition to the retractor lentis, the differences in the densities and pressures between these two fluids play an important role in the accommodation of the eye for distant or near vision by moving the lens forward or retracting it.

9. Chorioid

The chorioid is located between the retina and the sclera and is continuous with the outer part of the iris. At the time of the formation of the eye, the chorioid extends into the vitreal chamber through the embryonic ventral fissure. The chorioid is very thin anteriorly and increases in thickness posteriorly, the maximum thickness being around the optic nerve exit. It is highly vascularised and has pigment strips both on the retinal and scleral sides. The pigment in these strips is in the form of spherical or elliptical granules. The increase in the thickness of the chorioid posteriorly is due to the presence of masses of capillaries, which are known as the chorioid gland. The chorioid gland receives its blood supply from the

* When taken out with a syringe and tasted it resembles tears.

pseudobranch (vestigial hyoid gill, found on the inner side of the operculum), through an efferent artery. This artery breaks up into numerous capillaries in the chorioid gland. Blood from the chorioid gland is utilised in the general chorioidal circulation which nourishes the retina. Walls (1942) suggested that the chorioid gland probably reduces mechanical disturbance of the retina caused by changes in blood pressure in the circulation from the heart, by increasing or decreasing the size of the capillaries which form the gland. No guanine was seen in the chorioid of the Pacific salmon, although, guanine was found in the iris.

10. Falciform process

As mentioned before, the falciform process runs horizontal to the embryonic ventral fissure. It runs from the ora serrata to the point where the optic nerve leaves the retina and appears like a ridge. The retractor lentis arises from the anterior most tip of the falciform process. The falciform process is pigmented and numerous capillaries occur in the pigment. The falciform process and the hyaloid vessels (which appear, when present, on the inner surface of the retina) which are mutually exclusive have been termed "supplementary nutritive devices" by Walls (1942). The falciform process is supplied by an artery which enters the eye at the region of the optic nerve exit. The presence of blood vessels clearly suggests its nutritive function. In the sections of the eyes of embryos, alevins and most fry, it was seen that the ventral fissure has not closed completely and the origin of the falciform process can be followed. In serial sections it appears to be quite broad which might be due to the ventral fissure being still open. Figure 3 shows the falciform process in the sockeye emerged fry which appears to encircle a part of the ventral retina. The falciform process presented such an appearance in all the sections of embryos, alevins and fry. In dissections of the eyes of fry and adult salmon as well as trout the author found that the structure of the falciform process was very simple as described earlier and did not present the appearance of a structure encircling a part of the retina.

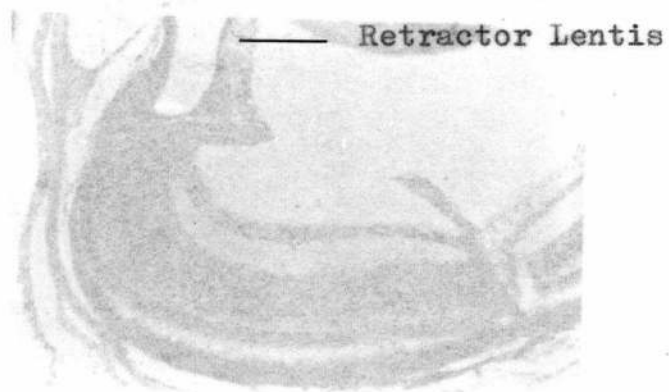
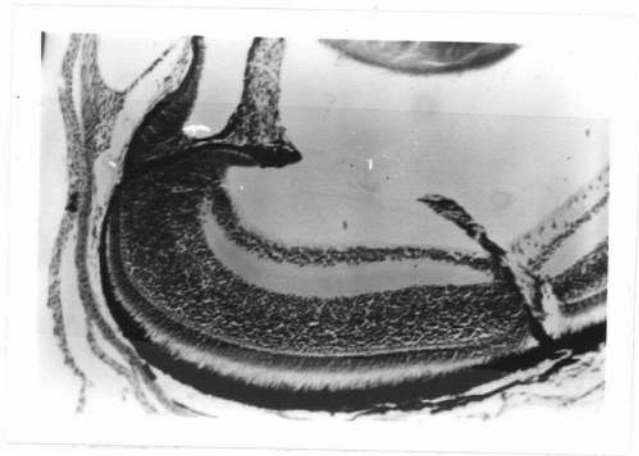

Figure 3. Photomicrograph of the falciform of an emerged fry, x100.



Since the whole head of the younger forms mentioned above was sectioned it appears that this appearance of the falciform process in the sections might be due to the orientation of the eye in the sections. In the sections of enucleated eyes the falciform process did not appear as it does in Figure 3. This appearance seems to be due to the axis of sections running a little diagonally to the optical axis.

11. Retina

A brief description of the Oncorhynchus retina has already been given (Ali and Brett, 1958). In this paper a more detailed description will be given based on a larger number of specimens and involving the use of a modified version of the Golgi silver impregnation technique.

The retina of Oncorhynchus consists of the following ten layers (Fig. 4):

- | | | |
|--|-------------------------------|---------------------------------|
| 1. Epithelial pigment layer | Non-nervous | } Neuro-
epithelial
layer |
| 2. Rod and cone (visual cell) layer | } Neurones of
first order | |
| 3. External limiting membrane | | |
| 4. External nuclear layer | | |
| 5. External molecular (plexiform, reticular) layer | | |
| 6. Internal nuclear layer | } Neurones of
second order | } Cerebral
portion |
| 7. Internal molecular (plexiform, reticular) layer | | |
| 8. Ganglion cell layer | | |
| 9. Nerve fiber layer | } Neurones of
third order | |
| 10. Internal limiting membrane | | |

No fovea was found in any one of the eyes. The blind spot (scotoma) is elliptical and is not situated in the centre of the optic cup but slightly ventral to the centre. Its orientation is naso-temporal (perpendicular to the longitudinal axis of the eye).

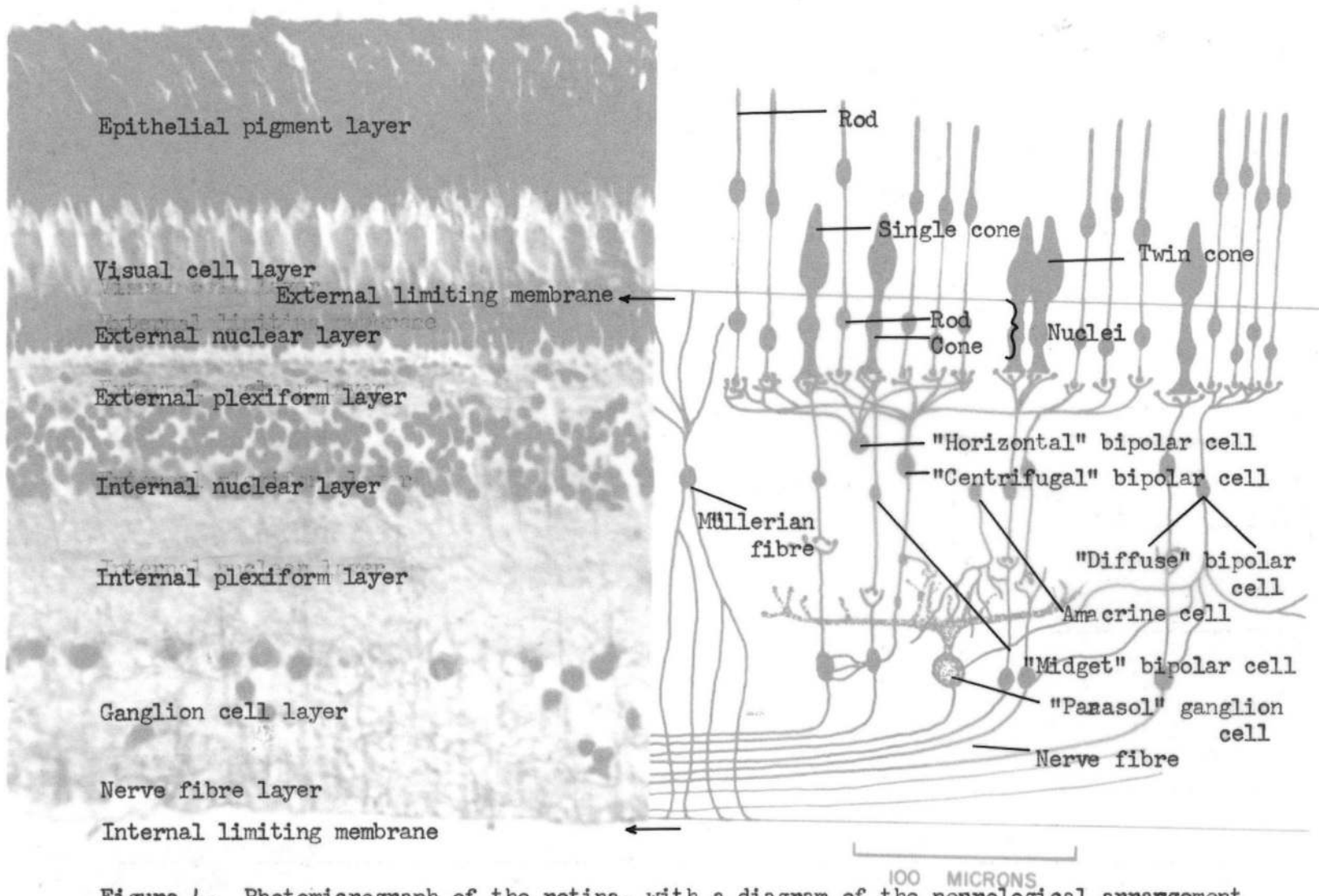
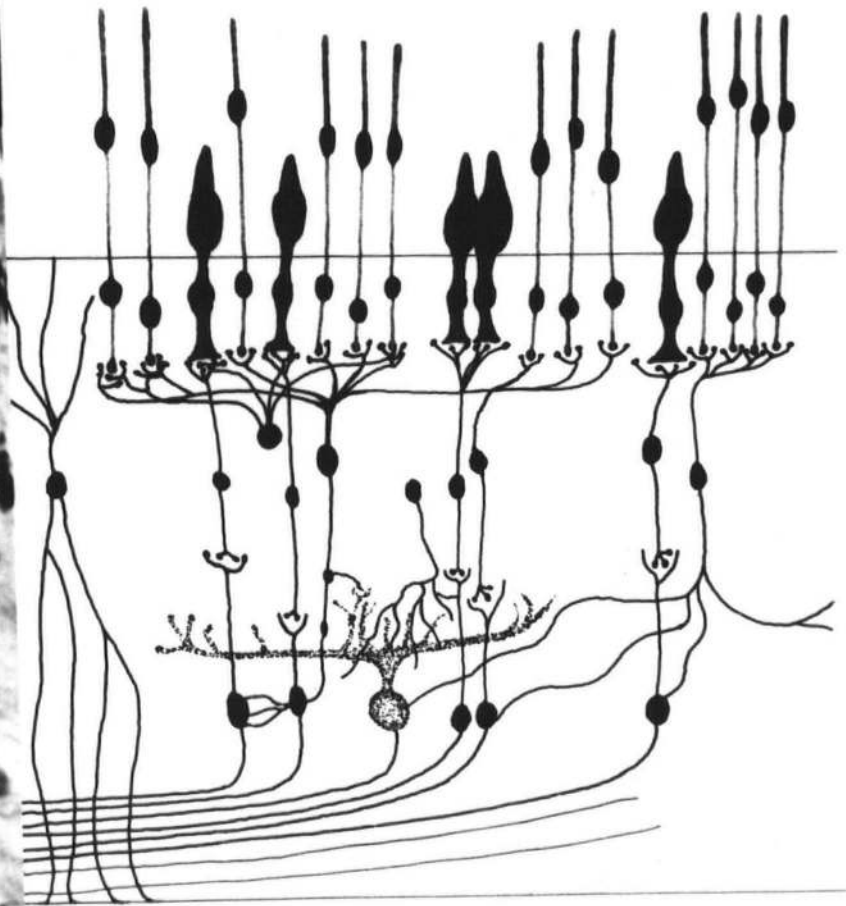
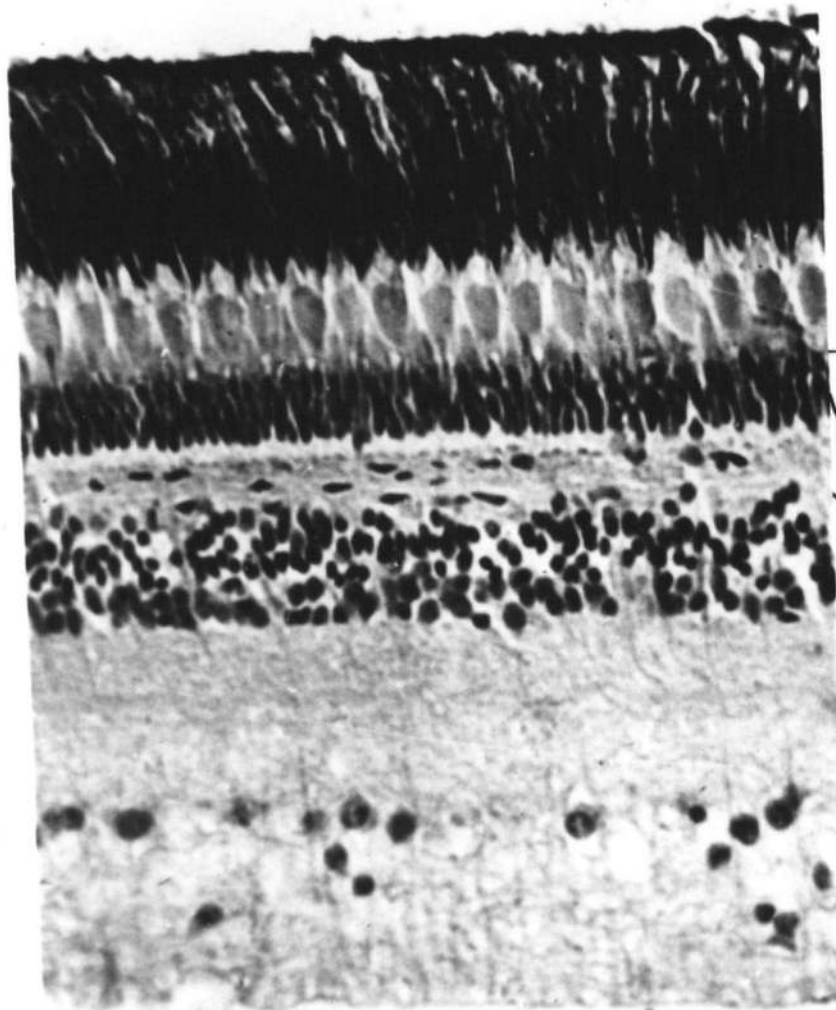

Figure 4. Photomicrograph of the retina, with a diagram of the neurological arrangement therein.



100 MICRONS

Figure 4 shows a photomicrograph of the Pacific salmon retina as well as a diagrammatic presentation of its neurological arrangement seen in Golgi preparations. The neurological arrangement shows greater similarity to that of the primate retina as illustrated by Polyak (1941, 1957) than to that of the teleostean retina depicted by Franz (1913). The "parasol" ganglia have not been described by Franz. Further, he shows a greater number of bipolar cells synapsing with each ganglion cell than is the case in Oncorhynchus (Fig. 4). The rod and cone myoids are also seen more prominently in the present investigation.

The appearance of the epithelial layer in its light as well as dark-adapted states is shown in Figure 5A. The pigment granules near the nucleus are spherical or slightly ellipsoid, whereas distally they are needle-shaped. In the dark-adapted state (Fig. 6A) they contract proximally and form a dense strip leaving the tips of the epithelial cells transparent and devoid of pigment. In some light-adapted eyes all the pigment migrates distally leaving the proximal parts of the epithelial cells, near the chorioid, free of pigment. This happens occasionally in all the species of Oncorhynchus studied and does not indicate any specific differences. However, in most cases only the needle-shaped granules migrate distally on illumination, leaving the spherical and ellipsoid ones near the nucleus.

The retina of Oncorhynchus possesses cones as well as rods, hence is duplex. Single, twin and rarely unequal twin* cones occur. In the region of the fundus they are arranged in neat, regular mosaics as shown in Figure 5B. This pattern is the same as that described by Eigenmann and Schafer (1900) for Salmo. In the ora serrata this pattern is not strictly adhered to and the cones are arranged in rows (Fig. 5B) without the formation

* These may be called double cones but due to their close similarity in structure to the twin cones and the striking difference between them and the double cones of other vertebrates, the author prefers to call them unequal twin cones. These occur very rarely in the Oncorhynchus retina, nevertheless, can be seen in a careful examination of preparations. If the sections are stained in eosin for two minutes instead of one, all the cone ellipsoids are more prominent. In his earlier investigation (Ali and Brett, 1958) the author did not observe them.

- Figure 5. A. Diagram showing parts of the retinal pigment, cones and rods and their positions in the light and dark-adapted stages.
- B. The arrangement of cones in the regions of the fundus and ora serrata.

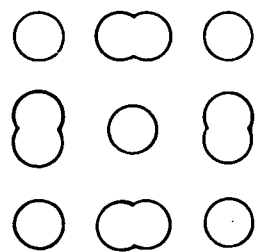
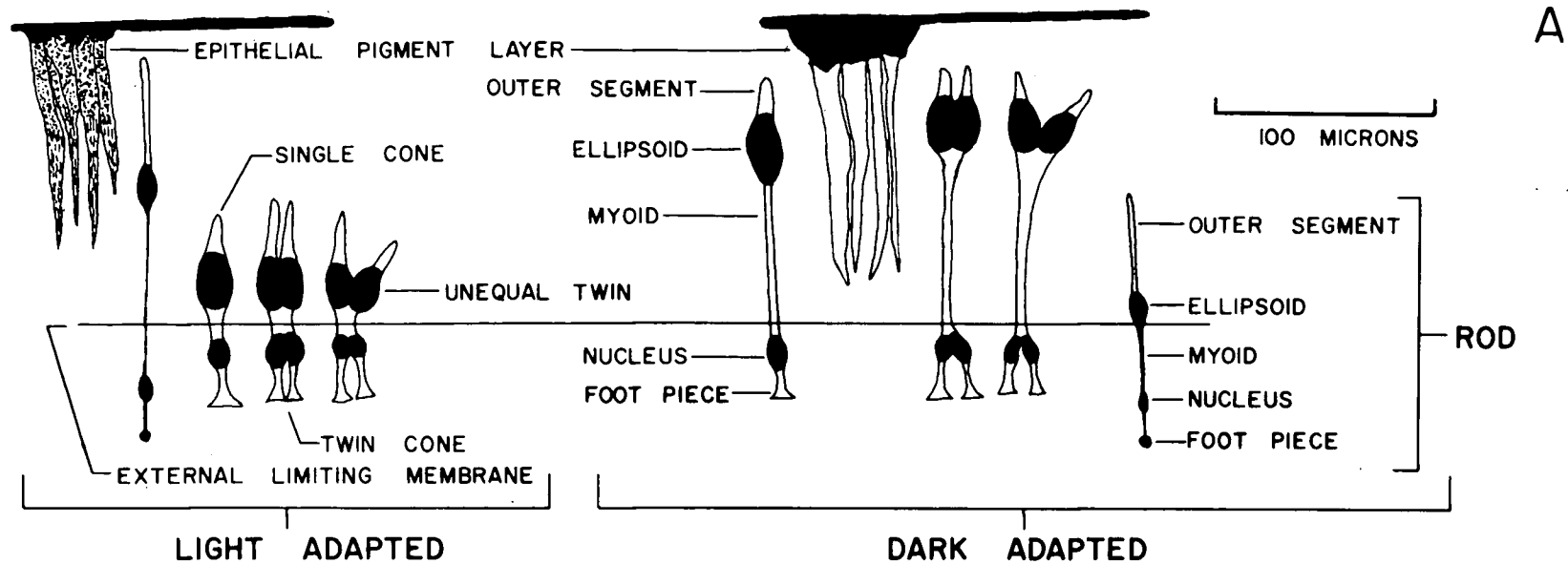

FUNDUS

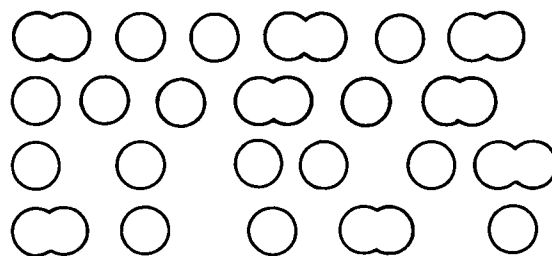

ORA SERRATA

CONE ARRANGEMENT

B

of any definite mosaics. Eigenmann and Schafer do not mention any such arrangement.

The outer sections of the cones are typically cone shaped (Fig. 5A) and their ellipsoids are elliptical, almost oval. The ellipsoids of the twin cones are attached while those of the unequal twin cones are attached only partly. The myoids of the twin cones are attached and just before their entrance through the external limiting membrane, they divide and each has a separate nucleus in the external nuclear layer. They have separate foot-pieces. The only place in which the single, twin and unequal twin cones differ from one another is in the ellipsoid portion. In the case of the twin cones the ellipsoids are fused with one another but each member can be clearly demarcated (Fig. 5A). In the unequal twin cones one member has a slightly smaller ellipsoid, but the two are attached to one another partially near their bases, unlike the double cones (lacking in Oncorhynchus) where one member is much smaller and is not attached to the larger member. In the double cones, the smaller member usually has an oil globule and migrates very little or not at all in the dark. In the unequal twins of the Pacific salmon both cones migrate in the dark following the expansion of their myoids. No differences in staining reactions were observed among the single, twin and unequal twin cones.

The foot-piece of the cone extends down as far as the external molecular layer and expands with several small projections at its end. These synapse with the branches of the extension from the "midget" bipolar cell and often with branches from the "horizontal" cell as well. In some areas such as the ora serrata, especially on the dorsal side of the retina, one cone (often 2 or 3) may synapse with branches from the "diffuse" bipolar cells, whose branches also have connexions with five or six rods. In the internal molecular layer, the branches from the "midget" bipolar cells synapse with branches from ganglion cells and the inner branches of the ganglion cells proceed as nerve fibres which are components of the optic nerve. The "horizontal" cells do not send any branches towards the internal molecular

layer (Fig. 4). The diffuse bipolar cells make connexions with the ganglion cells of cones or with the "parasol" ganglion cells, which in turn give off branches which are also nerve fibres that form the optic nerve.

The cones on the dorsal side of the retina are fewer and larger, while those on the ventral side are more numerous and more slender. This is pronounced in the emerged and late fry stages. In the retinae of these animals the internal nuclear layer and the ganglion cell layer are also much thicker. The pigment and cone layers on the ventral side of the retinae of emerged and late fry do not completely contract and expand in the dark.

An idea of the thicknesses of the cone and pigment layers in the different stages of the four species in question may be obtained from Figures 6 to 9, 18 to 21.

The rods (Fig. 5A) are slender and their outer sections are long, thin and sticklike. Their ellipsoids are small and oval. The rod nuclei are situated below the cone nuclei in most cases and their foot-pieces end in knobs (Fig. 5A) in the external molecular layer, where they synapse with the branches from "diffuse" bipolar cells and also, in most instances, with the branches from the "horizontal" cells. The rods are dispersed irregularly in between the cones. They are more numerous in the periphery and are fewer in the region of the fundus.

Since this investigation is primarily concerned with the retinal photomechanical and behavioural responses of the juvenile Pacific salmon to different light conditions, no attempt was made to study in detail, the number of visual cells in the different areas of the eye, their relative sizes and differences among the different stages.

The external nuclear layer contains the nuclei of the rods and cones. These nuclei are more or less ellipsoid. The slightly larger nuclei of the cones lie closer to the external limiting membrane.

The external molecular layer (Fig. 4) consists of the broad foot-pieces of the cones and the knob-like foot-pieces of

the rods. They synapse with the branches of the "midget", "diffuse", "horizontal" and "centrifugal" bipolar cells, in this layer.

The internal nuclear layer (Fig. 4) consists of the bipolar cells mentioned above along with the amacrine cells and Müllerian fibres.

The internal molecular layer (Fig. 4) is composed of synapsing fibres of the different bipolar cells and the branches from the ganglion and "parasol" ganglion cells.

The ganglion cell layer (Fig. 4) contains the cells mentioned in the previous paragraph and varies in thickness in the different stages. In the animals which have more numerous, slenderer cones on the ventral side of the retina, the ganglion cell layer is thicker (2 cells deep). When there are correspondingly larger numbers of cones, the internal nuclear layer is thicker due to the presence of larger numbers of "midget" bipolar cells. Usually each cone synapses individually with a single "midget" bipolar, which in turn synapses with one ganglion cell, increasing the thickness of the ganglion cell layer also.

The nerve fibre layer (Fig. 4), for obvious reasons, is thinnest in the region of the ora serrata and thickest at the region where the optic nerve leaves the retina.

Differences of eye structure among species of Oncorhynchus: No species differences have been noted in the many Pacific salmon eyes examined.

B. Differences among stages

Differences, however were observed among the stages studied. The following features are of main interest:

The autocan^{thion}thous layer, the cornea and the annular ligament are poorly developed in the embryo and recently hatched alevin. They attain maximum development in the late fry stage.

The epithelial pigment of the embryo retina is in a perpetually dark-adapted state (Fig. 10) and exposure to any intensity of light for any length of time does not cause the pigment to disperse. The finger like processes of the

epithelial cells, devoid of any pigment, are, however, to be seen. Even in the late alevin stage the pigment migrates only slightly, on illumination. In the older stages such as emerged and late fry, it undergoes dispersion in light and concentration in dark.

Cones are seen clearly in the embryo retina, but their myoids are always fully contracted, presenting the appearance of a constant light-adapted condition. Exposure to dark for any period of time does not cause an expansion. This situation changes somewhat in the alevin stage where cone myoids do possess the capacity to expand slightly in dark. In the older stages the cone myoids show marked expansion in dark and contraction in light.

No rods were found in the embryo retina. Some are seen in the alevin eye. In older stages the rods are clearly visible in the dark-adapted retinae and their myoids are capable of undergoing expansion in light and contraction in dark.

The internal nuclear layer is much thicker (approximately 10 times) than the external nuclear layer in the embryo. The situation changes as the animal grows older. The external nuclear layer thickens, with the addition of rods, and in the emerged and late fry the internal nuclear layer is markedly thicker only on the ventral side of the retina due to the greater proportion of cones there. This situation persists, to a certain extent, even in the smolt.

Another difference between the smolt and the younger stages is that the ventral side of the retina in the latter shows less marked photomechanical changes than those seen in the case of the former.

The ganglion cell layer of the embryo is also thicker (3 cells deep) than that of older stages. With age it decreases in thickness, possibly because the area of the retina also increases. In the late fry it is about one cell deep dorsally and two cells deep ventrally. In the smolts, the ganglion cells are more crowded on the ventral side than on the dorsal side. This, as mentioned elsewhere, is in accordance with the greater proportion of cones.

The molecular layers are very thin in the embryos (Fig. 10), and gradually attain the normal proportions with age.

In summary, the embryo possesses all the ten retinal layers (Fig. 10) which the older, fully developed stages possess; but in an entirely different proportion in thickness. The proportions gradually change as the animal gets older, eventually reaching a physiologically balanced state in the emerged or late fry. These observations find a parallel in the case of the development of the Guppy, Lebistes reticulatus (Müller, 1952).

C. State of a typical light-adapted retina (Fig. 4)

The pigment has migrated within the finger-like processes of the epithelial cells and by its expansion has completely enveloped the rods which are at this stage fully expanded distally due to the elongation of their myoids. The dispersion of the pigment on exposure to light is thus a device to mask the rods and to absorb excess light. The rods cannot be seen easily in the light-adapted retina unless the surrounding pigment is bleached.

The cones in this stage have migrated distally due to the contraction of their myoids and are seen in the narrow space between the external limiting membrane and the finger-like process of the epithelial cells, now full of pigment.

D. State of a typical dark-adapted eye (Fig. 14)

The pigment and the rods have contracted proximally and the cones have expanded distally. The rods may readily be observed in this state. The pigment, which is contracted (Fig. 16), is in the form of a thin, dense strip which separates from the rest of the retina in most preparations.

EXPERIMENTAL RESULTS

A. Light-adaptation

1. The process of retinal light-adaptation

When a dark-adapted eye (Fig. 16), as previously described, is exposed to light, the pigment (which is in a contracted state) starts to disperse and after a certain period, attains maximum dispersion. The cones (whose myoids are expanded thus keeping the ellipsoids near the contracted pigment strip) begin to migrate proximally due to the contraction of their myoids. The rods that are seen close to the external limiting membrane in the dark-adapted retina, start migrating distally* due to the expansion of their myoids. This process is triggered when the light-intensity increases to or above the cone threshold. It has also been shown that with higher light-intensity light-adaptation is quicker than with lower light-intensity (von Studnitz, 1933). von Studnitz (1933a) and Wigger (1937) have also found differences in the rates of light-adaptation, during different seasons of the year. The process of light-adaptation is continuous in the Pacific salmon unlike that in the goldfish (von Studnitz, 1933a; Wigger, 1937) and the silver mackerel (Kobayashi, 1957) where it is interrupted. The Pacific salmon light-adapt in approximately thirty minutes. The pigment, cones and rods usually take different times for complete light-adaptation but they do not show any latent period before commencing to migrate. In contrast, von Studnitz (1933a) and Kobayashi (1957) state that the visual elements of goldfish and silver mackerel show a latent period before beginning to light-adapt. In general, the cones take the shortest time of the three to light-adapt. No other changes, on exposure to light, are observed in the Pacific salmon retina.

* The terms proximal and distal are used in this paper to denote movements towards and away from the nucleus.

In the following pages a comparative account of the process and rates of light-adaptation is given for the various stages of the different species of Pacific salmon studied. The description will be dealt with, stage by stage and interesting features of the different species belonging to the same stage will be described and illustrated with photomicrographs, graphs, histograms and tables. In addition a table, summarising the results of previous investigations is provided for comparison (Table VI).

2. Embryos

None of the embryos, belonging to any of the four species studied, showed any photomechanical response on exposure to light. The pigment remained contracted and the cones that were contracted in the dark, remained so (Fig. 12). The graphs (Figs. 6, 7, 8 and 9) show the thicknesses of retinal pigment and cone layers of "dark-adapted" embryos exposed to light and sampled at various times mentioned therein. It is seen that they show no changes in thickness at all on exposure to light. Rods were not observed in any of the embryos examined.

3. Alevins (Hatching stage) (Figs. 6, 7, 8 and 9)

When the alevins kept in dark for a day are exposed to light and sampled at the intervals mentioned, their retinal pigment and cone layers seem to show a slight response as seen in microscopical examination. Their pigment seems to undergo a slight expansion and their cones some contraction. The means of thicknesses of these layers of animals sampled from 0 to 15 minutes after illumination are greater (in the case of the pigment layer) and lower (in the case of the cones) than those of the animals sampled from 20 to 70 minutes (Table II), except in the case of the pigment layers of coho and chum alevins, indicating that, on the whole, there has been a slight expansion of the pigment layer and contraction of the cone layer on exposure to light. This last observation lends support to the histological findings. In the case of the pink salmon alevins, no pronounced changes were observed even in the histological examinations. The most noticeable positional changes of the

Figure 6. Graph showing the rate of expansion of the pigment and contraction of the cone layers on exposure to light in the various stages of sockeye salmon.

- Pigment
- Cones

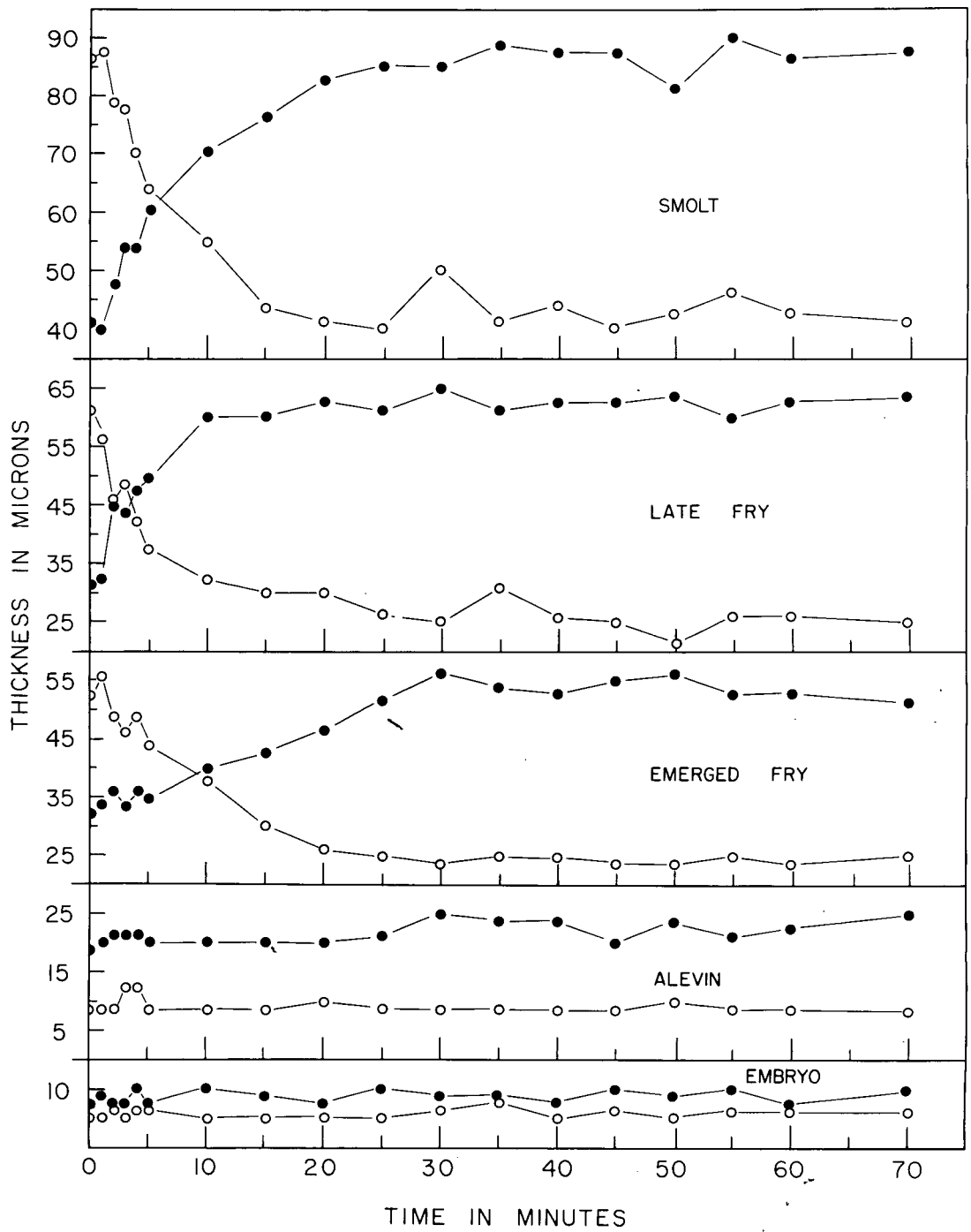

Figure 7. The rate of expansion of pigment and contraction of cones on exposure to light in the various stages of coho salmon.

- Pigment
- Cones

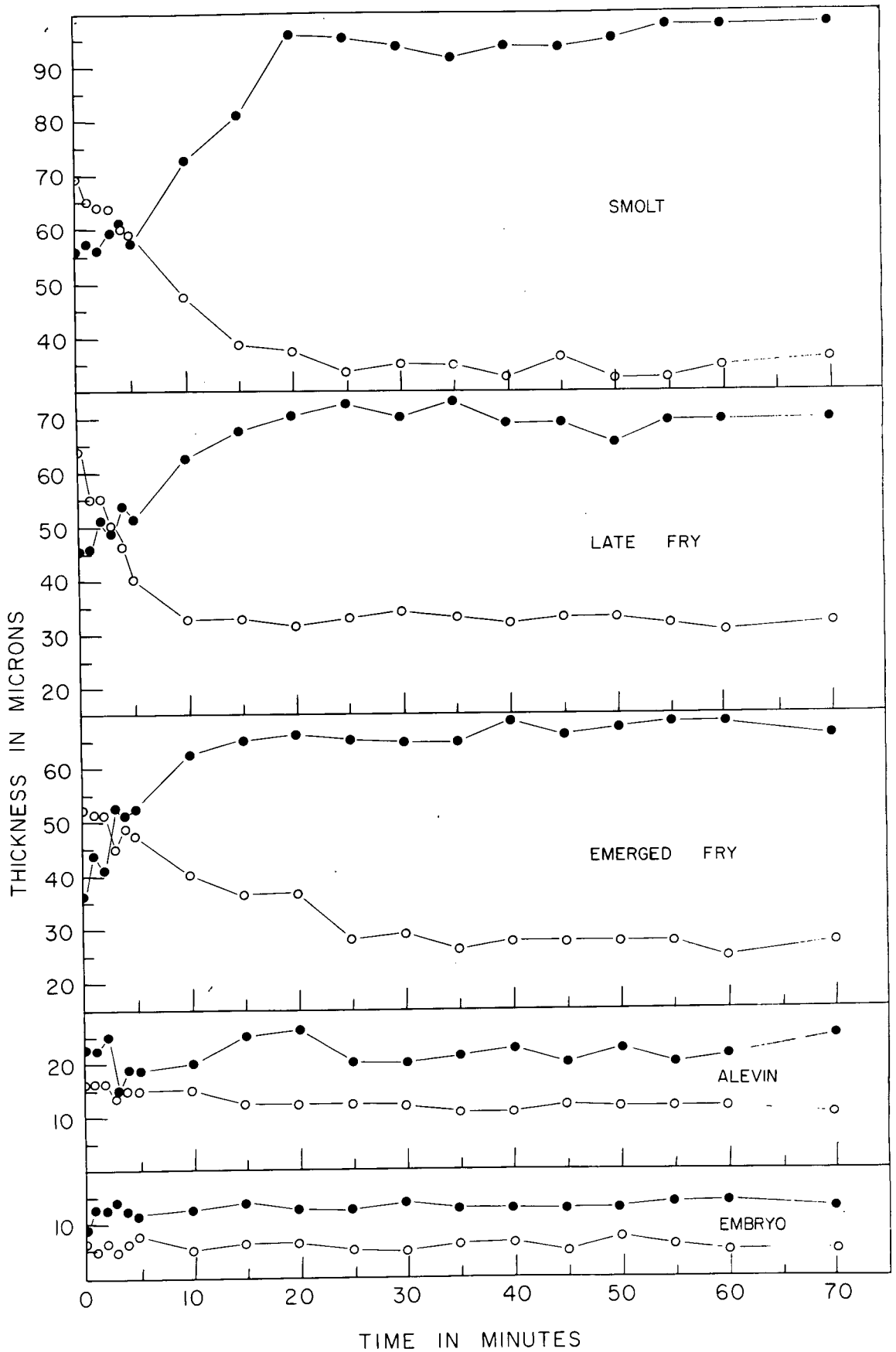

TABLE II - The average thicknesses of pigment and cone layers of alevins fixed at 0-15 minutes and 20-70 minutes after illumination. See Figs. 6, 7, 8 and 9.

Species	Average thickness of pigment layers (in microns)		Average thickness of cone layers (in microns)	
	0-15 min. after illum.	20-70 min. after illum.	0-15 min. after illum.	20-70 min. after illum.
Sockeye	20.28	22.92	9.72	8.88
Coho	21.55	21.38	14.72	12.08
Pink	20.00	20.41	12.70	12.70
Chum	26.02	21.47	12.27	9.72

Figure 8. The rate of expansion of pigment and contraction cones on exposure to light in the various stages of pink salmon.

- Pigment
- Cones

retinal pigment and cone layers were observed in the case of the coho alevin.

Rods were not observed except in very few preparations. The alevins used were newly hatched (about 24 to 48 hours after hatching), had large yolk sacs and stayed on the bottom of the tank without being able to swim about.

4. Emerged fry (no yolk sac) (Figs. 6, 7, 8 and 9)

a. Retinal response

The response of the retinae of dark-adapted emerged fry, on exposure to light, is immediate and in none of the animals did the pigment or cone layers have any measurable latent period before beginning to expand or contract, respectively. Table III shows the times taken by the retinal pigment and visual cells to light-adapt, the nature of their response, time taken to school on illumination and the times after illumination when the fish were able to catch maximum number of Daphnia. The nature of responses given either as linear or exponential are in some cases only approximate. The expansion of the pigment in all the species, with the exception of sockeye, is exponential, while the rate of contraction of the cone layers in all these cases, again with the exception of sockeye, is linear. In addition, the cones of coho, pink and chum light-adapt later than the pigment does, while the cones of sockeye do so earlier than the pigment. When the times taken by the pigment and cone layers to light-adapt are compared (Fig. 17) it is seen that both the pigment and cone layers of chum take the shortest time to light-adapt while the pigment and cone layers of pinks take the longest time. The pigment of the coho light-adapts sooner than the sockeye's, whereas the cones of the latter take a shorter time to light-adapt. Since the response (or rate of expansion or contraction) is not uniform in all the cases, comparison of curves whose equations have been determined becomes almost impossible. Some of the rates are exponential or almost exponential and in these cases theoretically full adaptation is attained only at infinite time, but the time of attainment of full adaptation in the case of visual elements that show a linear response is mathematically

TABLE III - The time for light-adaptation of pigment, cones and rods, nature of response, schooling and feeding rates of dark-adapted emerged fry on exposure to light. See Figs. 6, 7, 8, 9, 10, 11 and 17.

Species	Time for Light Adaptation (in min.)			Nature of Response		Time taken to school after illum. (in min.)	Minutes after illum. when max. feeding occurs
	Pigment	Cones	Rods	Pigment	Cones		
Sockeye	25	20	30	Linear	Exponential	15	20-25
Coho	15	25	25-30	Exponential	Linear	20	25-30
Pink	25	25	25	Exponential	Linear	15	25-30
Chum	10	20	25-30	Exponential	Linear	15	20-25

Figure 9. The rate of expansion of pigment and contraction of cones on exposure to light in the various stages of chum salmon.

- Pigment
- Cones

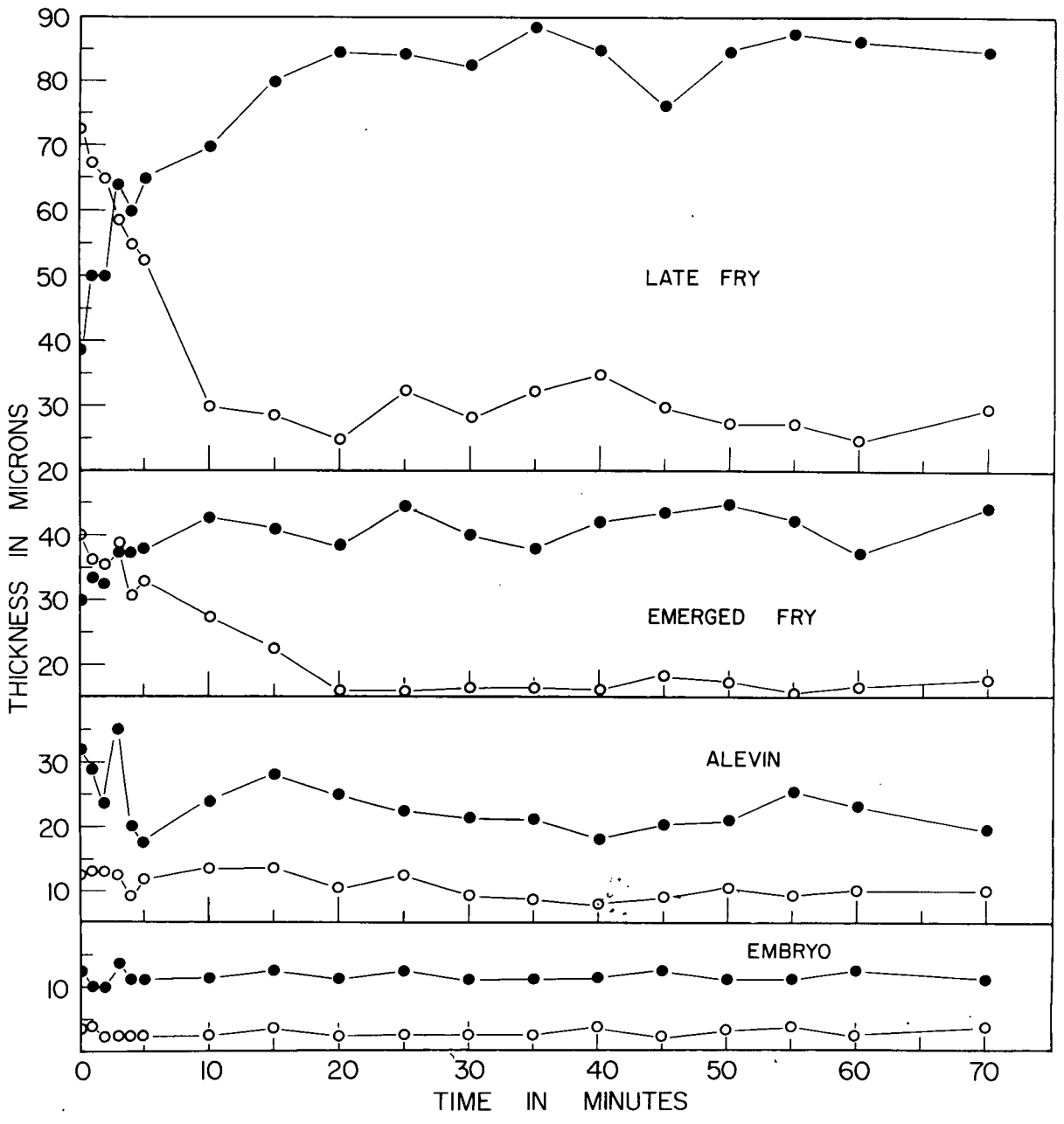
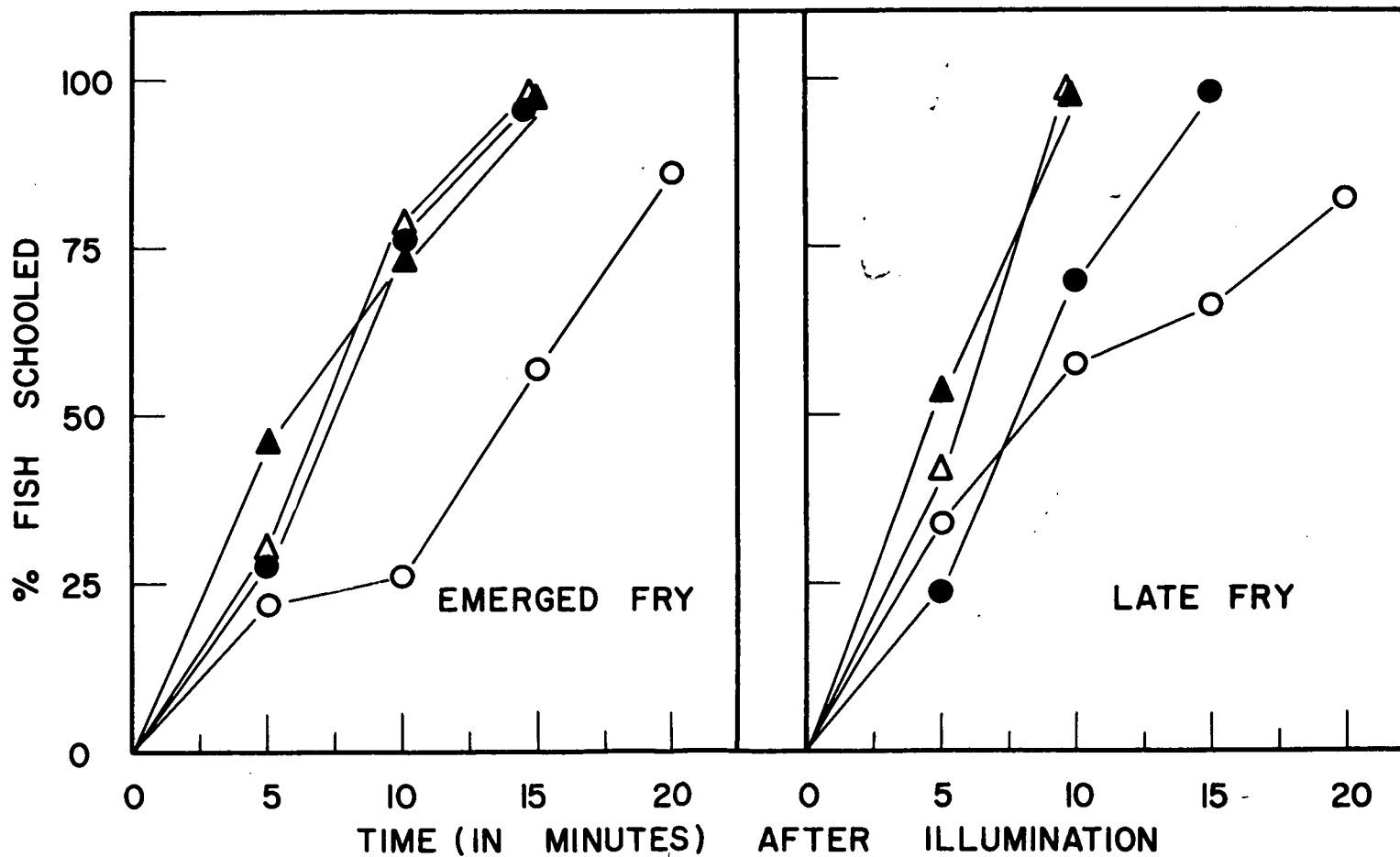

Figure 10. The rate of schooling of emerged fry, late fry of the four species, when dark-adapted fish are exposed to light.

- SOCKEYE
- COHO
- ▲ PINK
- △ CHUM



definite, hence comparison of the times for full adaptation of two curves, one exponential and the other linear, is not possible. However, in the case of both these responses the time taken for 99% adaptation is mathematically definite and can be compared. The time taken for full adaptation in the case of visual elements that had an exponential response was determined by checking the histological preparations and also the graphs where after a period, say 20 minutes, the pigment or cone layers reached maximum expansion or contraction and when the average of these values (of fully adapted elements) was taken and a line drawn through them, the point where the values of the thicknesses exceeded or fell below, this line, was taken as the time for full adaptation. This time for the present purposes seems fairly accurate, especially since it is supported by histological observations. Besides, the 99% values are only very slightly different (about 0.5 microns or less) from the full adaptation values. In view of this, in all the tables and histograms given in this paper by adaptation 99% adaptation is meant.

A point of significance is the difference between the thickness of the fully expanded and fully contracted epithelial pigment (Fig. 9) of the emerged chum fry. This difference is only 15 microns, as opposed to 25 to 35 microns in the case of the pigment as well as the cones of the other species. Even the cone layer of emerged chum fry shows a difference of 25 microns between the fully expanded and fully contracted cones.

b. Schooling rates

Figure 10 shows the rates of schooling of the emerged fry of all the four species studied, when dark-adapted animals are exposed to light. This shows no correlation with the adaptation times of either the pigment or the cone layers. In other words, schooling is not dependent upon complete light-adaptation. In general, sockeye, pink and chum seem to form a school consisting of most of the animals (50) used in the experiment, in about 15 minutes after illumination while the coho takes five minutes longer. Another observation that seems pertinent is that unlike the other species, coho school less readily and when

they do school, only about 85% of the animals under observation joined the school. The others swam around individually. In comparison, the emerged fry of the other species observed (Fig. 10) formed schools consisting of 96% or 98% of the animals used in the experiment.

Newly emerged fry of all the four species studied, which were in the covered trough in the dimly lit hatchery, do not form schools for the first two or three days, unless they are subjected to light of quite a high intensity (400 ft-c.). If left in the trough under unaltered light conditions, they gradually commence forming schools and after about three days are in a large school.

c. Feeding rates

The feeding rates of conditioned, dark-adapted emerged fry after various periods of illumination, are shown (Fig. 11). In every case the maximum rate at which the animals capture their prey occurs only at a time when the cones are also light-adapted as shown by histological examination (compare Figs. 11 and 6, 7, 8 and 9). The time at which maximum feeding occurs does not show any correlation with the time taken by the pigment to light-adapt fully. The time at which maximum feeding occurred also helped to determine the time for full adaptation of the cones for interspecific comparison, referred to above. From these experiments it would appear that maximum feeding indicates that the animal's visual acuity is at its best, and this time corresponds well with the time taken by the cones to contract (light-adapt) completely, showing the relationship between the cones and visual acuity.

5. Late fry

a. Retinal response

The response of the pigment and cones of the dark-adapted late fry of all four species is immediate and none of them has a measurable latent period (Figs. 6, 7, 8, 9 and Table IV). The rate of expansion of the pigment is exponential except in the case of coho, and in the case of the cones their rate of contraction is also linear, the chums, in this case,

Figure 11. The rate of feeding of conditioned dark-adapted emerged fry, late fry and smolts of the four species, on exposure to light.

- SOCKEYE
- COHO
- ▲ PINK
- △ CHUM

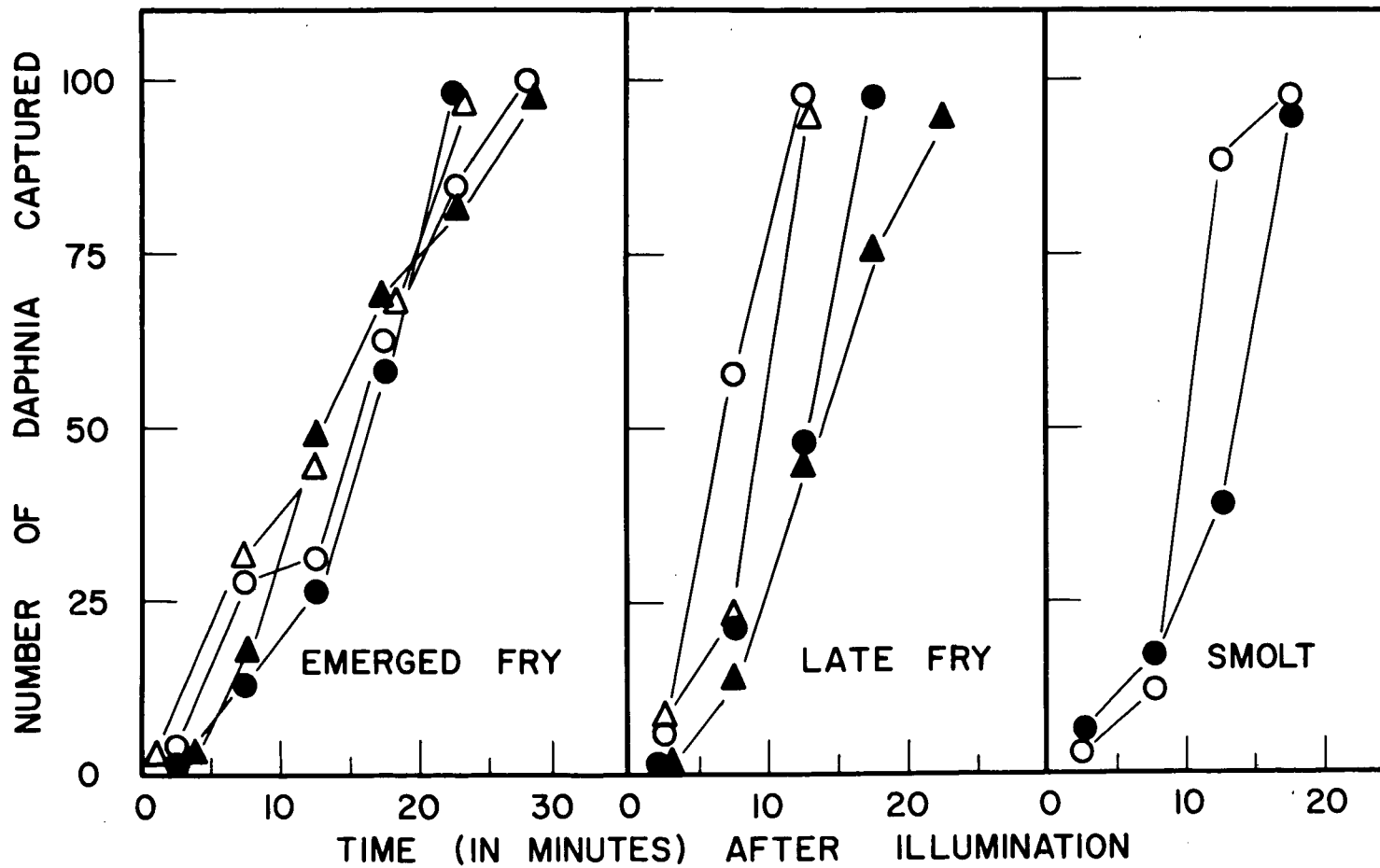

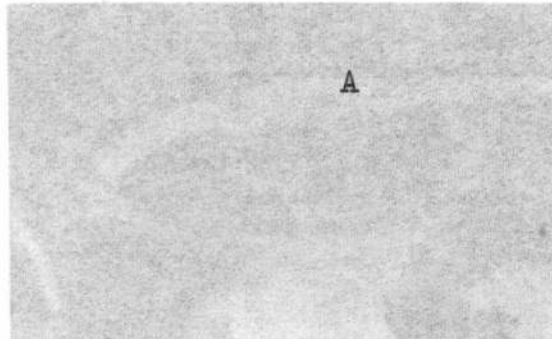
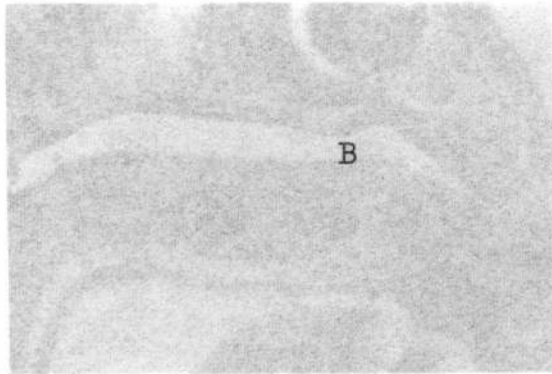

Figure 12. Photomicrographs of light-adapted (A) and dark-adapted (B) retinæ of late embryos. x115.



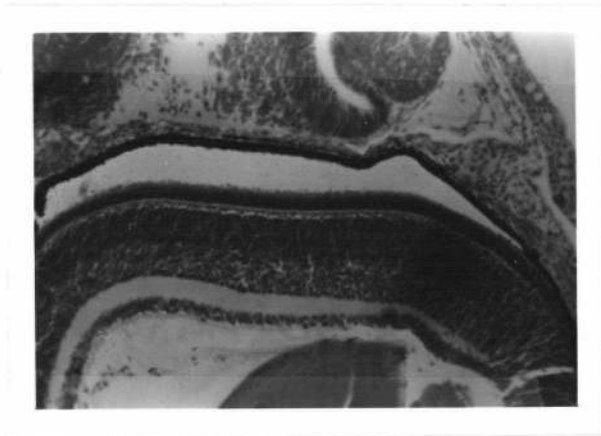
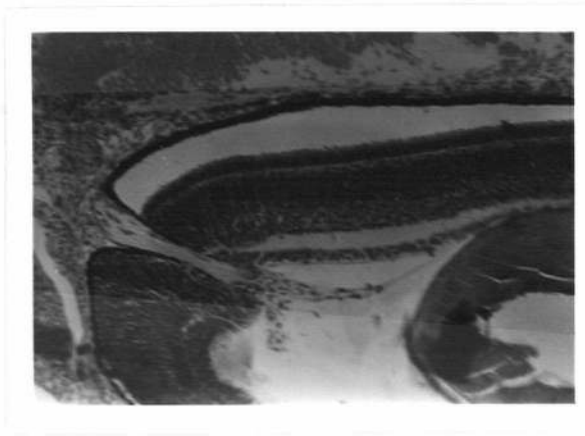

TABLE IV - The time for light-adaptation of pigment, cones and rods, nature of response, schooling and feeding rates of dark-adapted late fry on exposure to light. See Figs. 6, 7, 8, 9, 10, 11 and 17.

Species	Time for Light Adaptation (in min.)			Nature of Response		Time taken to school after illum. (in min.)	Minutes after illum. when max. feeding occurs
	Pigment	Cones	Rods	Pigment	Cones		
Sockeye	10	15	15-20	Exponential	Exponential	10	15-20
Coho	20	10	20	Linear	Exponential	20	10-15
Pink	20	20	25	Exponential	Exponential	10	20-25
Chum	20	10	20	Exponential	Linear	10	10-15

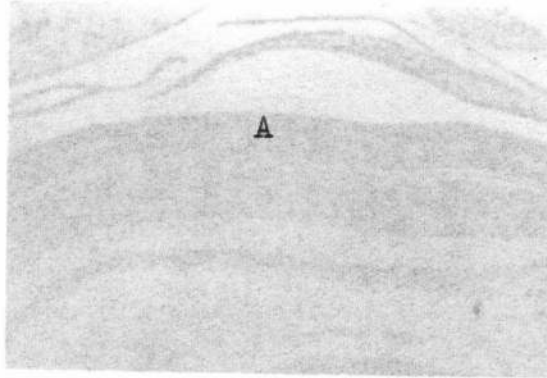
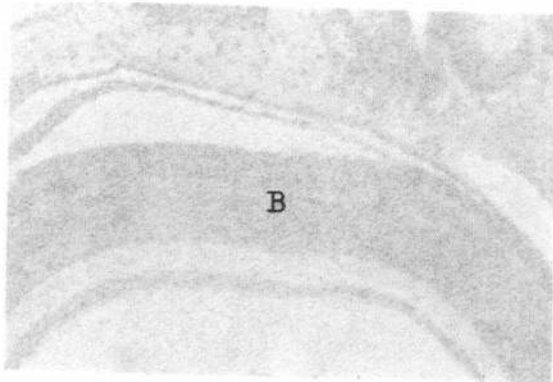
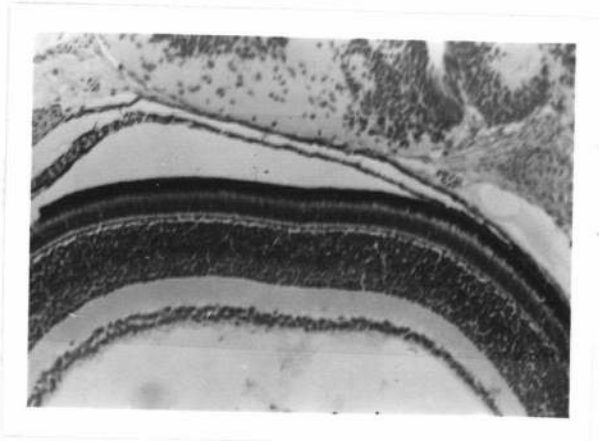
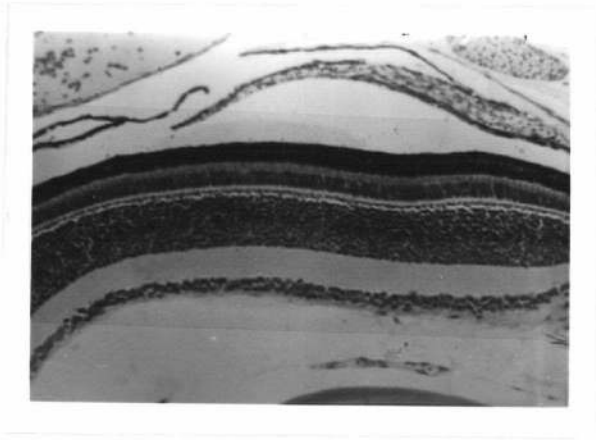

Figure 13. Photomicrographs of light-adapted (A) and dark-adapted (B) retinæ of alevins. x110.





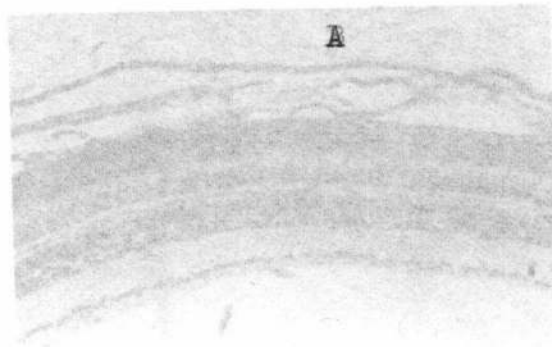
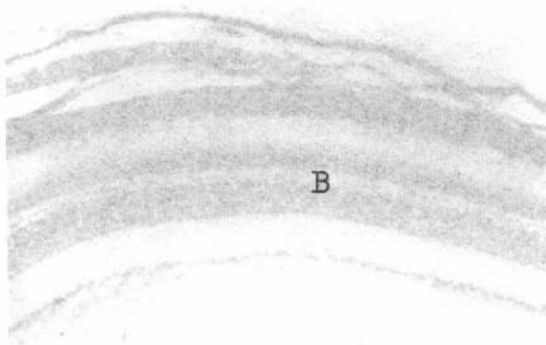
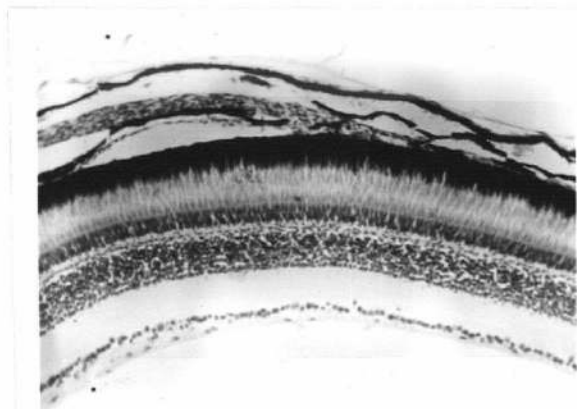
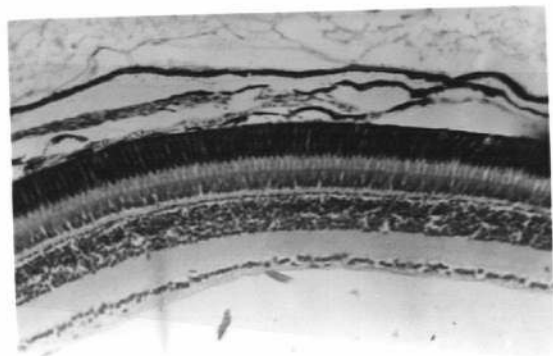

Figure 14. Photomicrographs of light-adapted (A) and dark-adapted (B) retinae of emerged fry. x120.





being the exception. The pigment of the sockeye late fry is light-adapted ten minutes after illumination while that of the other three species is light-adapted in 20 minutes (Fig. 17). The cones of coho and chum light-adapt earliest, ten minutes, while that of the sockeye light-adapt in 15 minutes followed by pink in 20 minutes.

Certain points of interest may be mentioned. In the case of the late sockeye fry the rate of pigment expansion on illumination is exponential as compared with that of the emerged sockeye fry where it is linear.

The cones of the late sockeye fry light-adapt five minutes after the pigment, as opposed to the case in the emerged fry and smolts whose cones light-adapt before the pigment. In the case of the coho, the cones of the late fry light-adapt in ten minutes in contrast to the cones of the emerged fry which take 25 minutes to contract maximally. In the case of the late chum fry, the difference between the fully contracted and the fully expanded pigment layer is 50 microns as compared with the emerged fry where the difference is only 15 microns. The emerged sockeye fry showed differences from the emerged fry of the other species whereas the late sockeye fry do not show any marked differences from the other species. The only aspect in which some difference is seen between late sockeye fry and late fry of other species is the time taken by the pigment to light-adapt. The pigment of the late sockeye fry takes the least time to light-adapt (19 minutes).

b. Schooling rates (Fig. 10)

The dark-adapted late fry of sockeye, pink and chum form schools consisting of 98% of the fish under observation in ten minutes while the coho take 20 minutes to do so. As in the case of the emerged coho fry, the late fry also do not school readily and when they do school, only about 80% of the experimental animals form the school. The time taken to form a school, in the case of the sockeye and late coho fry corresponds with the time taken by their pigment layers to expand maximally. In the case of pink no correlation either with the pigment or cones is seen while in the chum the time taken to school is the same as the time taken by the cones to light adapt (10 minutes).

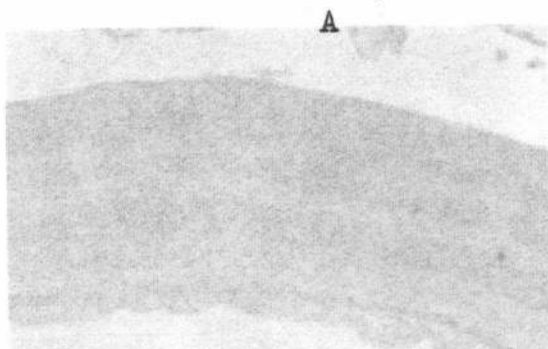
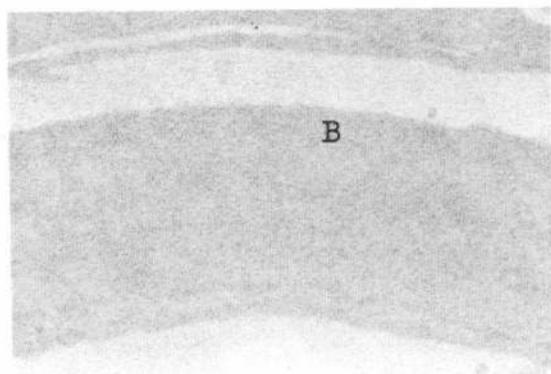
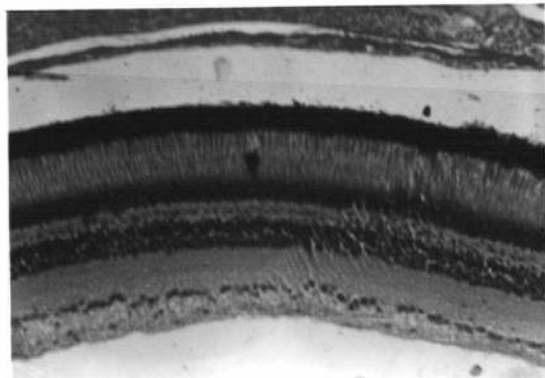
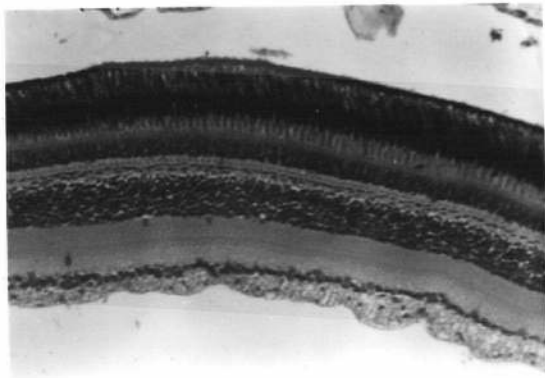

Figure 15. Photomicrographs of light-adapted (A) and dark-adapted (B) retinae of late fry. xl25.





c. Feeding rates

The coho and chum are able to capture 96% to 98% of the Daphnia offered ten minutes after illumination while the sockeye and pink take longer times (Fig. 11 and Table IV). However, in all cases the time after illumination at which maximum feeding occurred is the same as that taken by the cones to light adapt. In the case of the pinks where the pigment and cones take the same time (20 minutes) to light-adapt this correlation extends to the pigment also. As mentioned in the case of the emerged fry, here also, it is seen that full visual acuity is reached when the cones are light adapted, enabling the capture of maximum number of Daphnia possible.

6. Smolts

a. Retinal responses

The pigment and the cones start expanding and contracting immediately after the lights are turned on. The pigment of coho shows a slower movement for the first five minutes (Fig. 7). The rate of response of the pigment as well as the cones of the sockeye is exponential while that of the pigment and cones of the coho is linear. In both the species the pigment light adapts in 20 minutes and the cones in 15 minutes (Figs. 6 and 17).

b. Schooling rates

The smolts of sockeye and coho failed to form schools in the experimental tank on exposure to light*. A group of 50 fish were observed at five minute intervals for half an hour and at one half hour intervals for the next hour and a half yet they showed no signs of school formation.

* The smolts as well as the emerged and late fry of all the four species seemed to be alarmed (?) on illumination and showed something that resembled escape behaviour, but this lasted only for a brief period (about a minute, sometimes less) after which they quietened down. This alarm reaction seemed more accented in the case of the smolts, probably because they swim faster and are much larger than the fry. Among the fry, both emerged as well as late, the sockeye and coho seemed to show a more pronounced reaction than the pink and chum fry. These observations seem to agree with those of Hoar et al (1957). At the time the present experiments were conducted, the author was not aware of the findings of Hoar et al loc. cit., or he would have observed these reactions more closely.

A

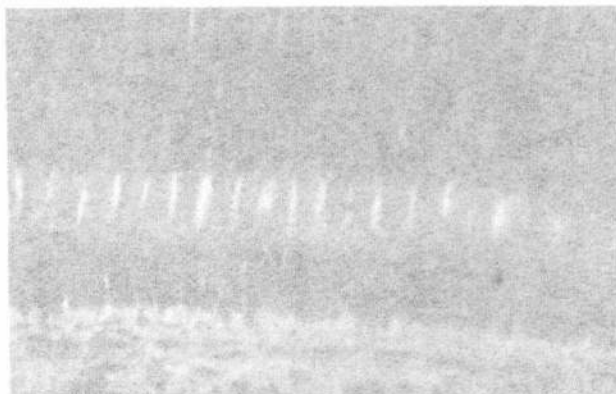
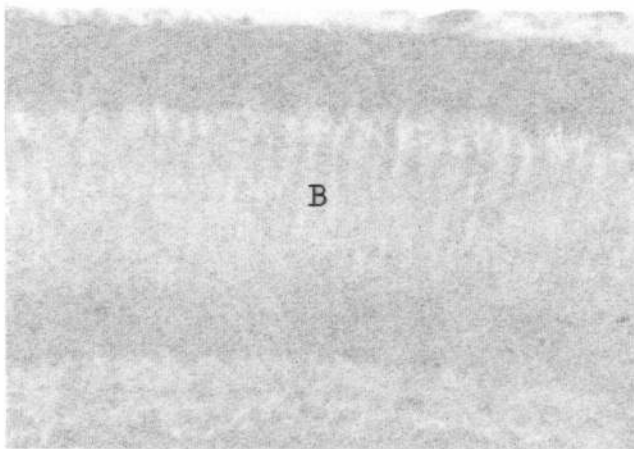

Figure 16. Photomicrographs of light-adapted (A) and dark-adapted (B) retinae of smolts. x500.

B



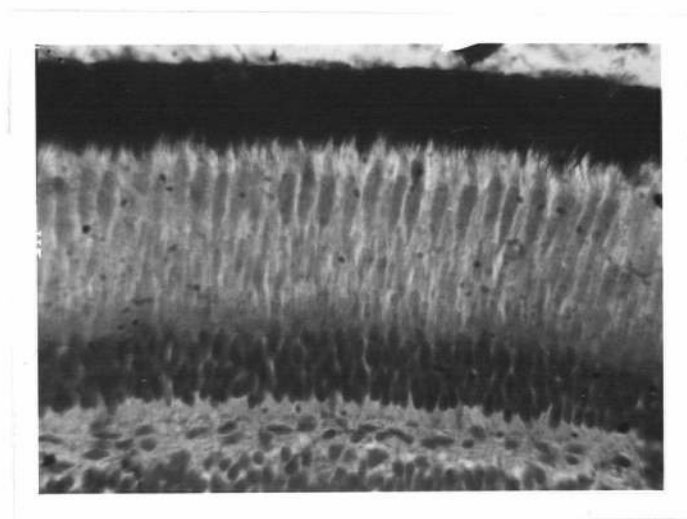
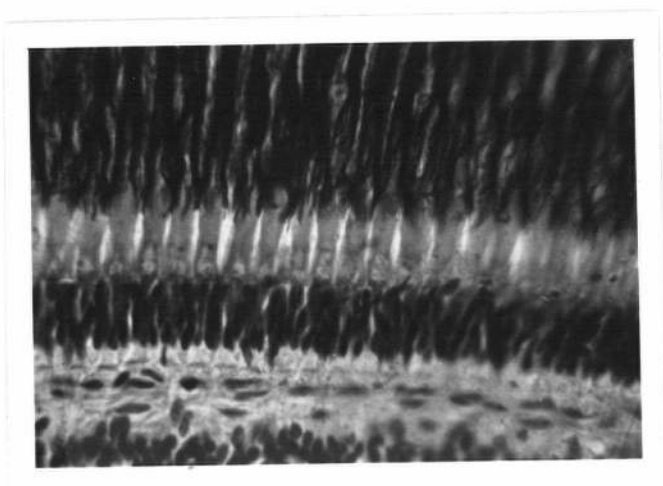

TABLE V - The time for light-adaptation of pigment, cones and rods, nature of response and feeding rates of dark-adapted smolts exposed to light. See Figs. 6, 7 and 11.

Species	Time for Light Adaptation (in min.)			Nature of Response		Minutes after illum. when max. feeding occurs
	Pigment	Cones	Rods	Pigment	Cones	
Sockeye	20	15	20-25	Exponential	Exponential	15-20
Coho	20	15	20-25	Linear	Linear	15-20

Occasionally, two or three fish were observed to swim together but this lasted for only a short time after which they separated. Nothing like the school of the emerged and late fry described above was ever observed.

c. Feeding rates

In both the species maximum feeding occurred 15 minutes after illumination (Fig. 11). Here also, as in the case of the emerged and late fry, it is seen that this time is the same as that taken by the cones to light-adapt (Figs. 6, 7, 8, 9 and 11). The sockeye smolts take the same time as the late fry to light adapt (15 minutes), but a longer time than the emerged fry (Fig. 17). The coho smolts, on the other hand, take a longer time than the late fry but a shorter time than the emerged fry (Fig. 17).

B. Dark-adaptation

1. The process of dark-adaptation

When a light-adapted eye, whose description has been given previously (Fig. 4), is subjected to darkness, the dispersed, needle-shaped pigment granules which are in the finger-like processes of the pigment epithelial cells (Fig. 5A) start to concentrate proximally, eventually (approximately 45-5 minutes, depending on the species and/ or stage) forming a thin, very dark strip (Fig. 5A) around the nuclei, leaving the processes of the pigment epithelial cells transparent. The cone ellipsoids which are seen near the external limiting membrane (Fig. 5A) due to the contraction of their myoids, begin to migrate distally due to the elongation of their myoids, finally taking their dark-adapted position close to the dense pigment strip. The rod myoids which are elongated in light (Fig. 5A) commence contracting, bringing the rod ellipsoids closer to the external limiting membrane, where they remain in the dark-adapted state (Fig. 5A). Latent periods before the contraction of pigment and expansion of cones in dark have been described both in Trachurus (Kobayashi, 1957) and Oncorhynchus nerka (Ali and Brett, 1958). In the present investigation no latent period prior to the expansion of cones in dark was observed in any of the species or

Figure 17. Histogram showing the times taken by the pigment and cones of emerged fry, late fry and smolts of the four species, to light-adapt.

PIGMENT

CONES

SOCKEYE

COHO

PINK

CHUM

EMERGED FRY

LATE FRY

SMOLT

SOCKEYE

COHO

PINK

CHUM

0 10 20 0 10 20 0 10 20
TIME (IN MINUTES) FOR LIGHT ADAPTATION

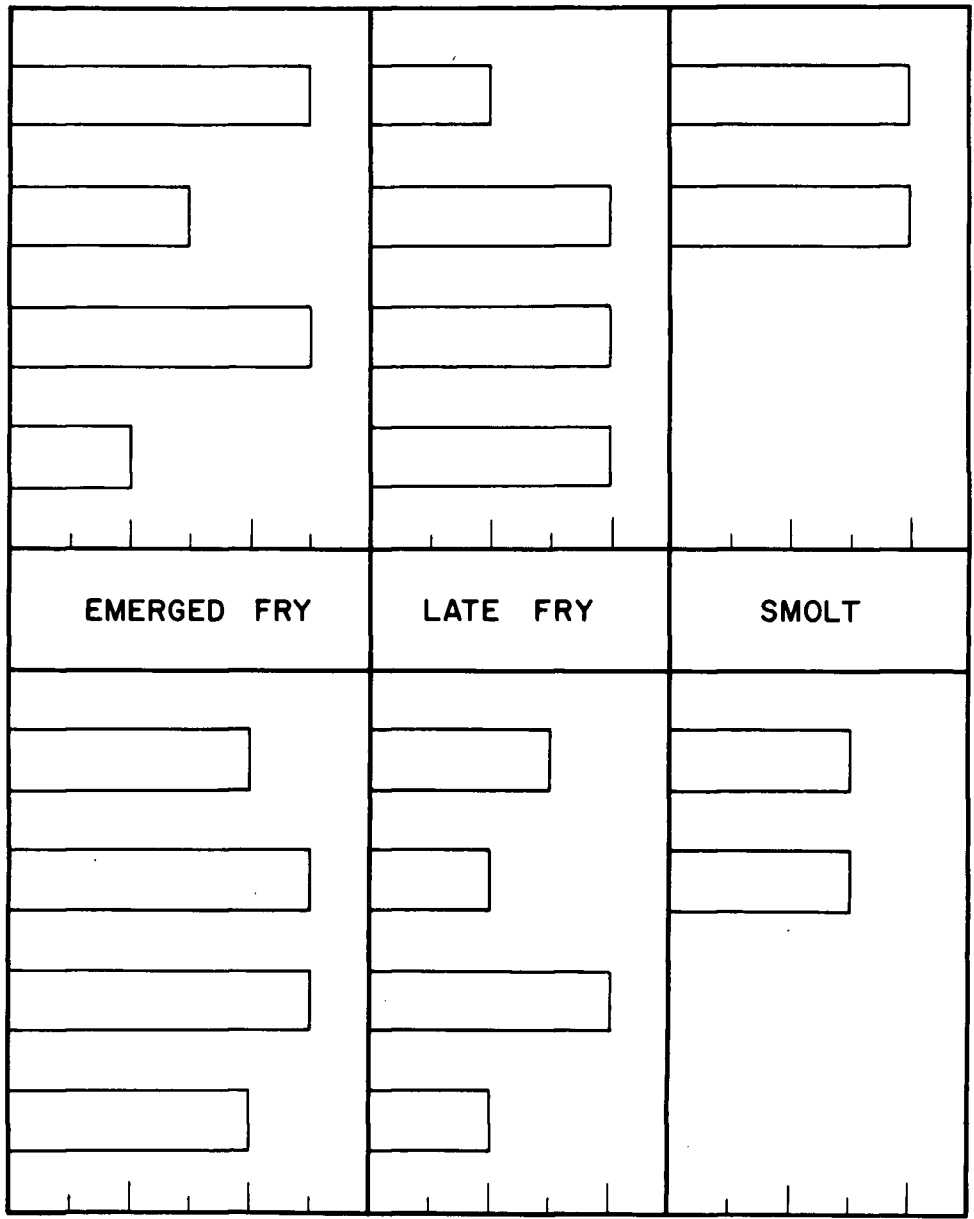
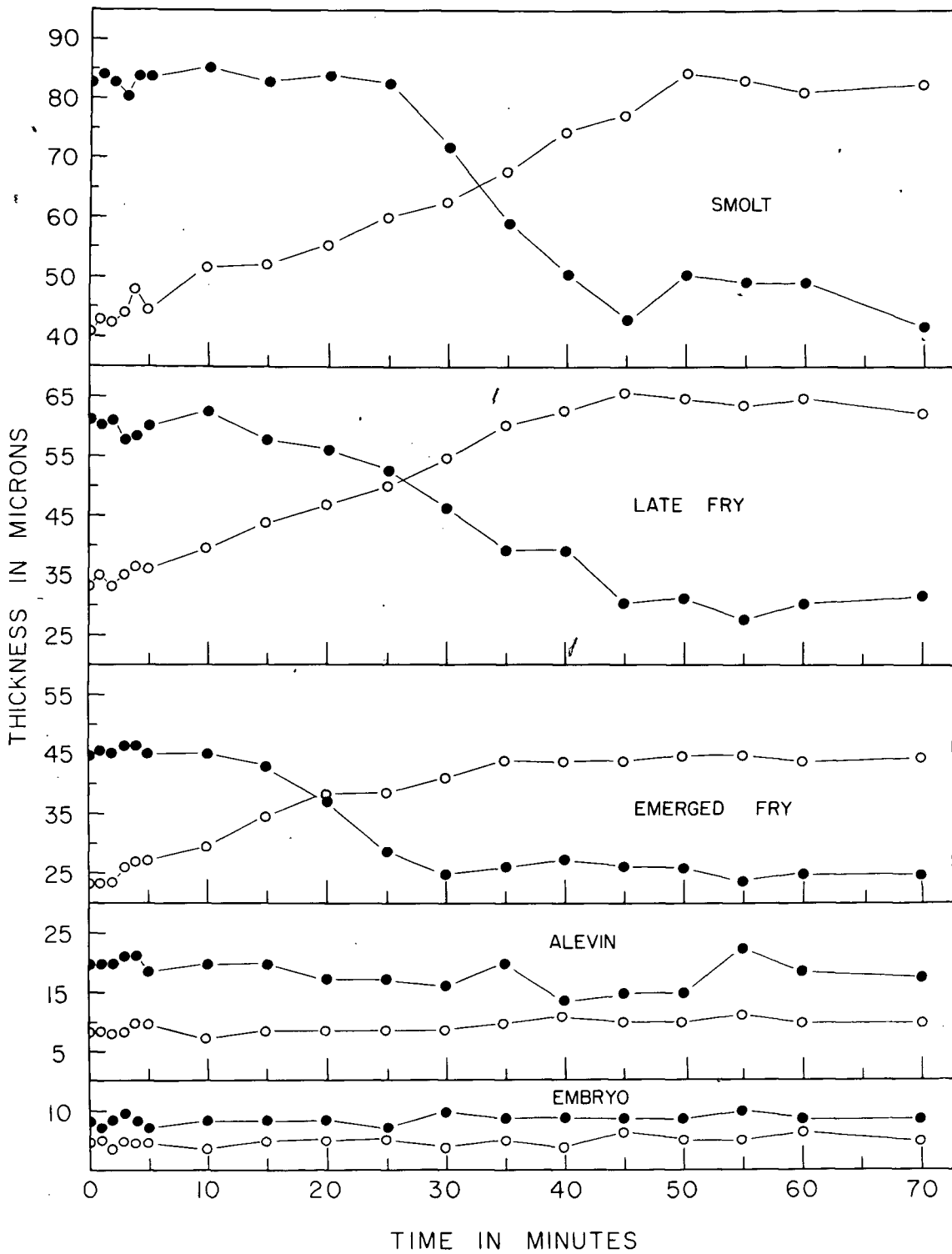

TABLE VI - Summarising the latent periods and time for light-adaptation of certain other species of fish studied by previous workers.

Species	Latent Period			Time for Light-adaptation			Reference
	Pigment	Cones	Rods	Pigment	Cones	Rods	
<u>Leuciscus rutilus</u>	2	5		30	20		Pergens, 1896
<u>L. aul</u>	1			60			Chiarini, 1904
<u>Anguilla</u>				120			von Hess, 1902
<u>Carassius auratus</u>	2	2	-	30	30		von Studnitz, 1933a
<u>Anguilla</u>	2	2	-	35-40			do.
<u>Ameiurus nebulosus</u>	-	-	-	60		45	Arey, 1916
<u>Fundulus heteroclitus</u>	-	-	-	60			do.
<u>Abramis crysoleucas</u>	-	-	-	45	45		do.
<u>Carassius auratus</u>	-	-	-				do.
<u>C. auratus enucleated eye</u>	-	-	-	40	40	-	Wigger, 1937
<u>Trachurus japonicus</u>	-	-	-	30	30	-	Kobayashi, 1957
<u>Oncorhynchus nerka</u>	-	-	-	16-18	15-20	40	Ali and Brett, 1958

Figure 18. Rate of contraction of pigment and expansion of cones in dark in the various stages of sockeye salmon.

- Pigment
- Cones



stages studied but in the case of the pigment a latent period generally occurred prior to the commencement of contraction in the dark. On the whole, the process of dark-adaptation is slower than that of light-adaptation. The reason for this appears to be that light is an active stimulus whereas darkness is not.

In the following pages the process of dark-adaptation in the different stages of the four species of Pacific salmon in question will be dealt with, as in the case of light-adaptation, stage by stage. Tables summarising the information for each stage are given (Tables VII, VIII, IX and X). In addition, the results of previous workers have been tabulated (Table XI) for comparison.

2. Embryos

As seen in Figures 12, 18, 19, 20 and 21, none of the embryos exhibit any movement of either the pigment layer or the cones, on exposure to dark. Histologically also, no changes in the thicknesses of the pigment and cone layers are observed when the "light-adapted" embryo is subjected to darkness. Rods were not seen in any of the preparations.

3. Alevins (hatching stage)

Graphs (Figs. 18, 19, 20 and 21) show the thicknesses of the pigment and cone layers of light-adapted alevins sampled at various times after darkening the room and demonstrate no pronounced changes in thicknesses of these layers. However, examination of the sections of their eyes reveals a slight contraction of the pigment and expansion of the cones in the dark. Also, it is seen that in the alevins of all the four species the means of the thicknesses of the pigment layer and cone layer sampled from 0 to 15 minutes are consistently higher or lower, respectively, than the means of the thicknesses of these layers of animals fixed from 20 to 70 minutes (Table VII). The points on the graphs show marked variation, but on the whole, a tendency of the pigment layer to contract and the cones to expand can be observed (Fig. 13). Very slender rods were seen in some of the preparations.

Figure 19. Rate of contraction of pigment and expansion of cones in dark in the various stages of coho salmon.

- Pigment
- Cones

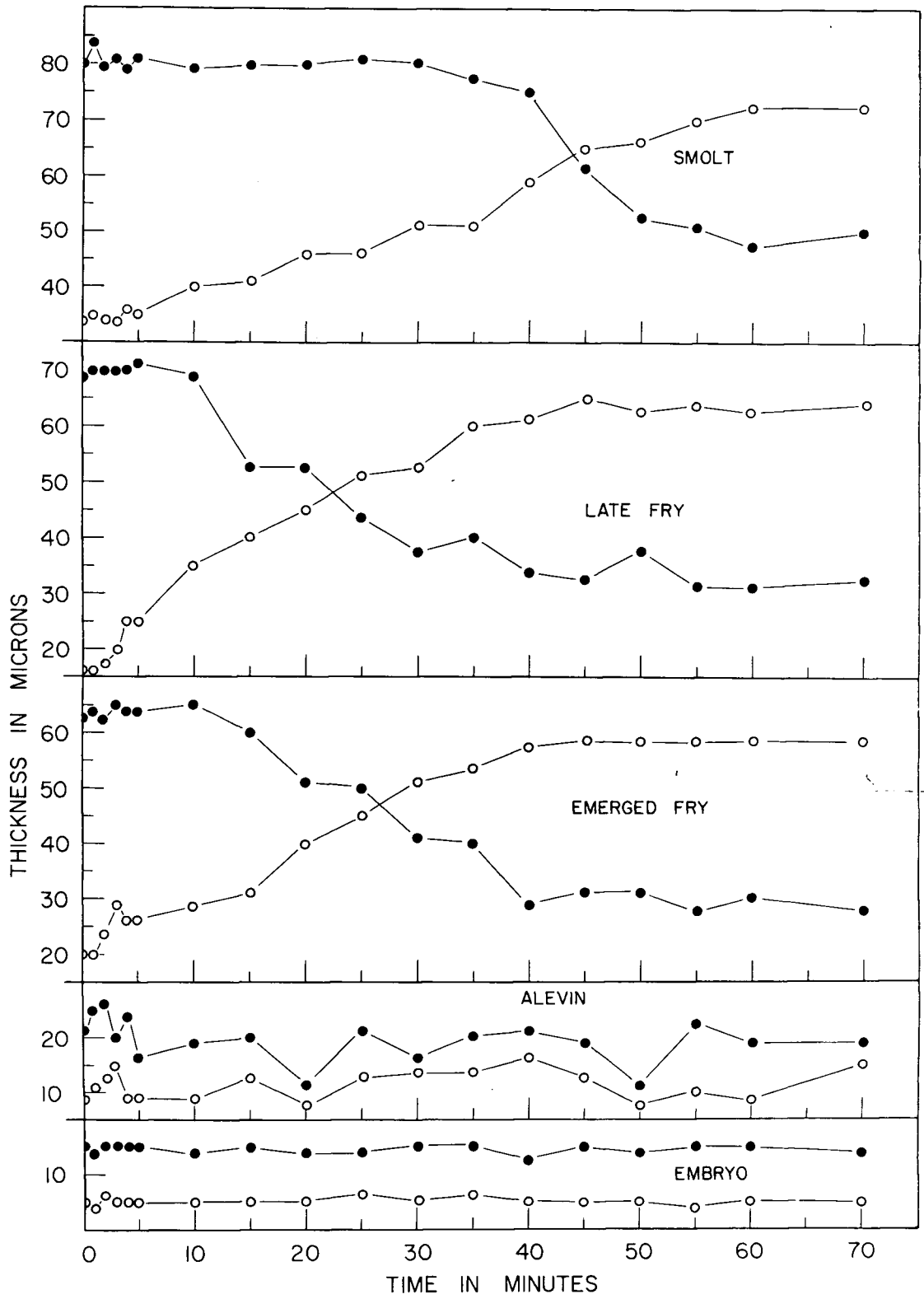

TABLE VII - Average thicknesses of pigment and cone layers in alevins fixed at 0-15 minutes and 20-70 minutes after light-adapted alevins were exposed to dark. See Figs. 18, 19, 20, 21 and 22.

Species	Average thickness of pigment layers (in microns)		Average thickness of cone layers (in microns)	
	0-15 min. after dark	20-70 min. after dark	0-15 min. after dark	20-70 min. after dark
Sockeye	19.86	17.36	8.80	10.00
Coho	20.29	18.75	10.41	12.22
Pink	19.30	16.80	12.08	15.41
Chum	25.27	24.33	13.99	16.11

4. Emerged fry (post yolk sac)

On subjection to dark, the pigment of the emerged fry retina shows a latent period before beginning to contract. This varies interspecifically. The pink has the shortest (5 minutes) latent period, while the chum has the longest (15 minutes). The sockeye and coho both have a latent period lasting for ten minutes (Fig. 22 and Table VIII). After this latent period the pigment begins to contract and in all species except the sockeye, it is linear. The contraction of the sockeye's retinal pigment is exponential. The retinal pigment of the pink takes the longest time to contract maximally (45 minutes). Another point of interest in the case of the pink is that its pigment remains in the half contracted state for 25 minutes (from 15 to 40 minutes after dark), between the time it starts to contract after the initial latent period, and the time it attains maximal contraction.

As in the case of light-adaptation, the recently emerged chum fry exhibit only a small difference in the thickness between the fully expanded and fully contracted epithelial pigment layer (17 microns). In comparison, the difference between their fully contracted and fully expanded cone layers is 22 microns.

The cones of the species have a latent period before commencing migration distally. In all cases, the response is linear (Figs. 18, 19, 20, 21 and Table VIII). The chum cones take the shortest time (20 minutes) and the coho cones take the longest (40 minutes).

5. Late fry

The epithelial pigment layers of all the species with the singular exception of the pink possess a latent period before commencing contraction (Figs. 18, 19, 20, 21, 22 and Table IX). It may be recalled that in the emerged fry stage the pink had a latent period of five minutes, which was the shortest as compared with the other species. The rate of contraction of the pigment is exponential in the coho, pink and chum, while in the sockeye it is linear. The sockeye pigment is maximally contracted after 45 minutes, in contrast with the pink whose pigment takes the

TABLE VIII - The time for dark-adaptation of pigment, cones and rods, the latent periods and natures of response of emerged fry. See Figs. 18, 19, 20, 21 and 22.

Species	Latent period before the commencement of the contraction of pigment (in min.)	Time for Dark-adaptation (in min.)			Nature of Response	
		Pigment	Cones	Rods	Pigment	Cones
Sockeye	10	30	35	15	Exponential	Linear
Coho	10	40	40	25	Linear	Linear
Pink	5	45	35	25	Linear	Linear
Chum	15	30	20	15	Linear	Linear

Figure 20. Rate of contraction of pigment and expansion of cones in dark, in the various stages of pink salmon.

- Pigment
- Cones

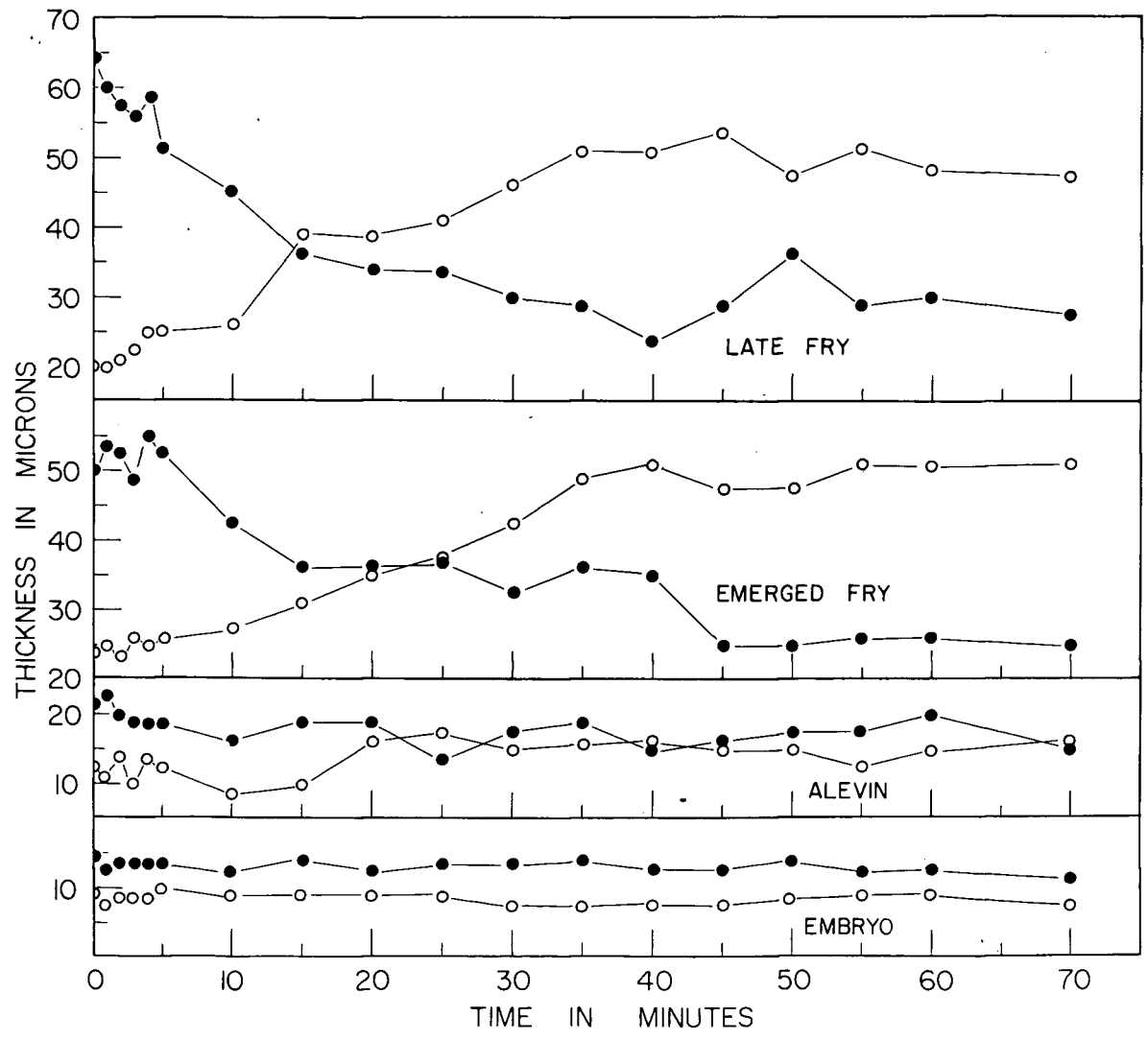
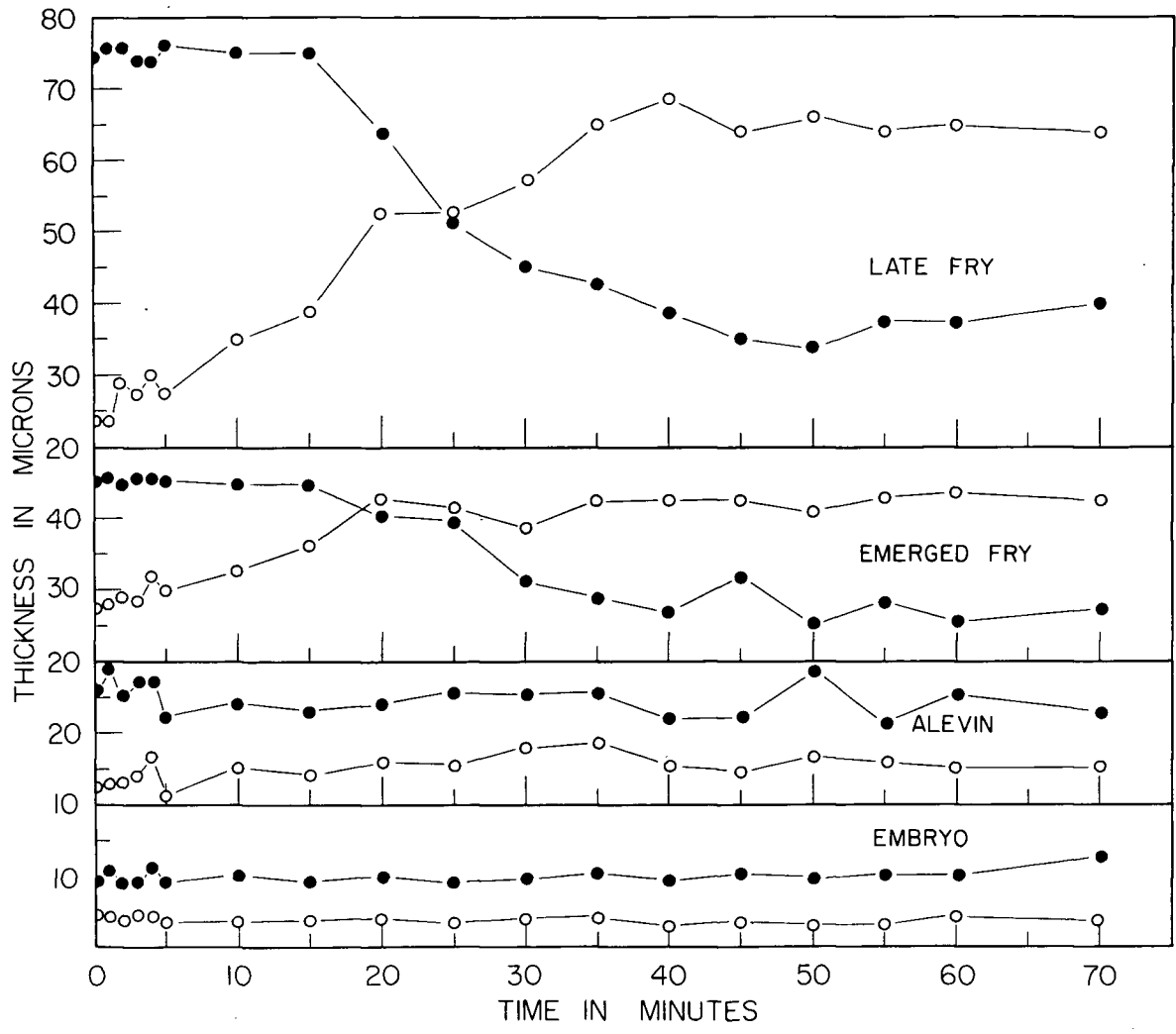

TABLE IX - Times for dark-adaptation of pigment, cones and rods, latent periods and natures of response of late fry. See Figs. 18, 19, 20, 21 and 22.

Species	Latent period before the commencement of the contraction of pigment (in min.)	Time for Dark-adaptation (in min.)			Nature of Response	
		Pigment	Cones	Rods	Pigment	Cones
Sockeye	15	45	40	15-20	Linear	Linear
Coho	10	35-40	35-40	20	Exponential	Exponential
Pink	-	30	35	15	Exponential	almost Exponential
Chum	15	40	35	20	Exponential	Linear

Figure 21. Rate of contraction of pigment and expansion of cones in dark, in the various stages of chum salmon.

- Pigment
- Cones



shortest time (30 minutes) to contract fully.

None of the species shows a latent period before the commencement of the expansion of its cone myoids in dark (Figs. 18, 19, 20, 21, 22 and Table IX). In the case of the cones also, those of the sockeye take the longest time to expand fully, that is, 40 minutes. The other species take 35 minutes to do so. In addition, the response of the sockeye cones is linear while those of the others show an exponential rate, although that of the pink's is not so clear in that it almost resembles an exponential and certainly is not linear.

6. Smolts

The pigment layers of both sockeye and coho possess latent periods, but that of sockeye is somewhat shorter (25 minutes) than that of the coho's (30 minutes). The rate of contraction of the sockeye retinal pigment is linear while that of the coho is exponential, but they both take the same time to contract fully (Figs. 18, 19, 20, 21 and Table X).

The cones of both the species possess no latent period before beginning to expand, but like the pigment, the sockeye cones show a linear response, as against the exponential response of the coho cones. The cones of sockeye take a longer time to light-adapt (50 minutes). The coho cones do so after 40 minutes of dark.

C. Retinomotor and Behavioural Responses to Different Light Intensities

Retinal photomechanical changes elicited by low light intensities are similar to the process of dark-adaptation. When the intensity of light falls below their threshold the retinal elements commence to migrate towards their dark-adaptation states. After the light intensity starts decreasing below a certain level, the pigment begins to contract and seems to take various positions ranging from the fully expanded (light-adapted) state to the maximally contracted (dark-adapted) state, thereby regulating the amount of light absorbed inside the optic cup. This process exposes the rods which have been shielded by the pigment.

TABLE X - Times for dark-adaptation of pigment, cones and rods, the latent periods and natures of response of smolts. See Figs. 18, 19 and 22.

Species	Latent period before the commencement of the contraction of pigment (in min.)	Time for Dark-adaptation (in min.)			Nature of Response	
		Pigment	Cones	Rods	Pigment	Cones
^S Sockeye	25	40	50	20-25	Linear	Linear
Coho	30	40	40	20	Exponential	Exponential

Figure 22. Histogram showing the times taken by the pigment and cones to dark-adapt. Solid positions of the bars represent the latent time before reactions.

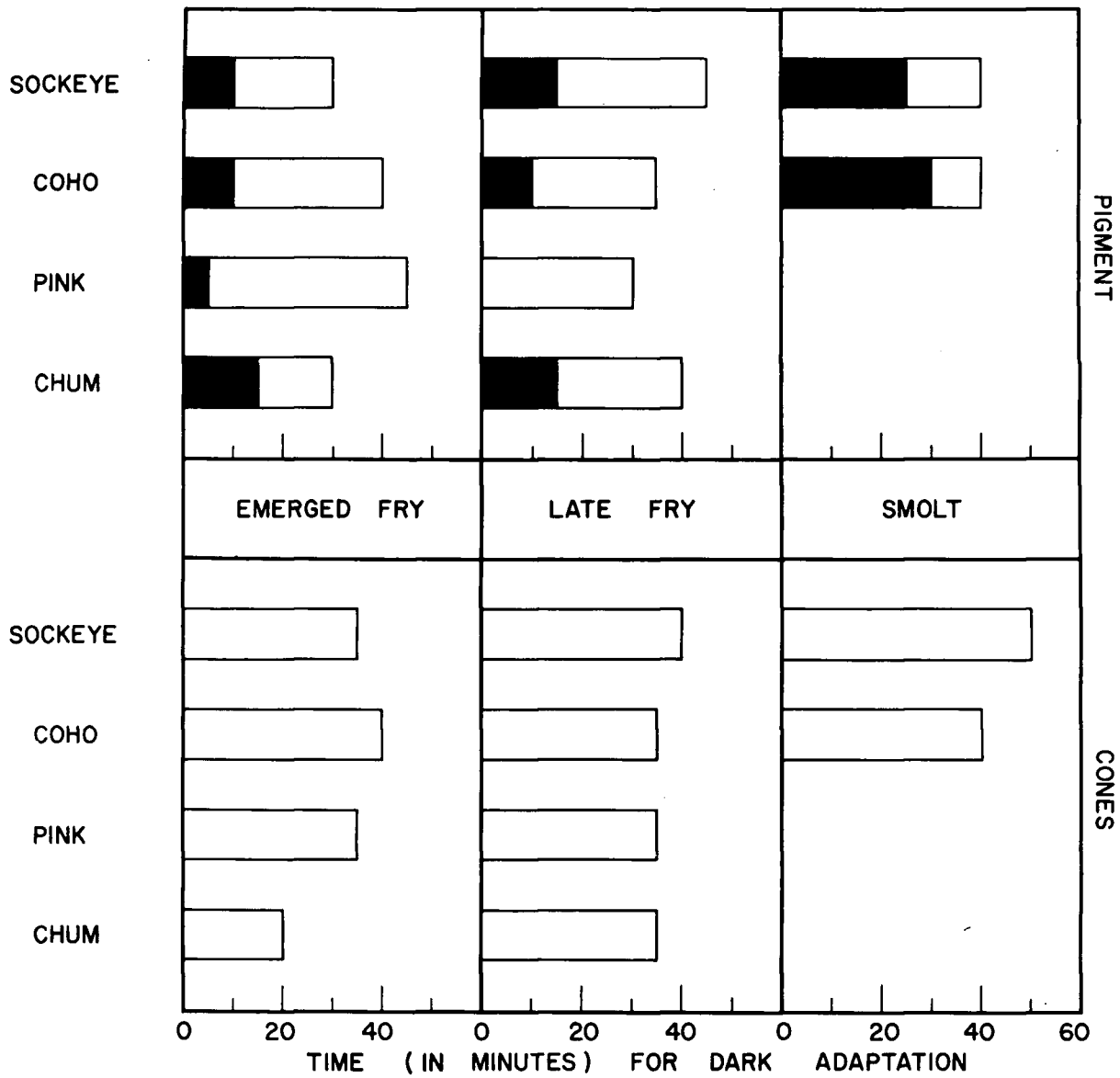

TABLE XI - Times for dark-adaptation of pigment, cones and rods, the latent periods of certain fish studied by previous investigators.

Species	Latent Period			Time for Light-adaptation			Reference
	Pigment	Cones	Rods	Pigment	Cones	Rods	
<u>Leuciscus rutilus</u>	1	-	-	20			Pergens, 1896
<u>L. aula</u>	5	-	-	60			Chiarini, 1904
<u>Ameiurus nebulosus</u>	-	-	-	60		30	Arey, 1916
<u>Fundulus heteroclitus</u>	-	-	-	45-60			do.
<u>Abramis crysoleucas</u>	-	-	-	30	30		do.
<u>Carassius auratus</u>	-	-	-				do.
<u>Trachurus japonicus</u>	5-10	5-10	-	90			Kobayashi, 1957
<u>Oncorhynchus nerka</u>	12	16	-	56-60	55-60	24	Ali and Brett, 1958

When the light intensity falls below their threshold, the cones commence migrating distally so as to enable the rods (so it would appear) to take their positions closer to and directly in the path of the incoming light quanta. Thus, it is seen, that declining light intensity, when it reaches a certain level or levels triggers these three individual responses. At very low intensities all the three retinal elements assume dark-adapted states.

When the cones are closest to the external limiting membrane (light-adapted state) due the contraction of their myoids, the visual acuity of the animal is at its best and in the case of the Pacific salmon this is demonstrated by their feeding rates, which are at their maximum when the animal is fully light-adapted.

As the animal's eyes become adapted for scotopic vision, the cones are fully elongated, since the light intensity is far below their threshold. In this state, the scotopic visual elements, the rods, with their low thresholds come into play. As long as the light intensity is above their threshold, the light sensitive rods can detect movements and large objects and the presence or absence of light. In the case of the Pacific salmon, it may be said that rod threshold is indicated by the dispersion of a school at a particular intensity or in the case of the feeding response, the intensity above the one at which feeding altogether stops due to the inability of the animal to distinguish the silhouette or movement of the prey (*Daphnia*). The change from photopic or scotopic vision is also indicated by the change in the fish's mode of capturing its prey. In photopic vision the animal swims about in the tank at all depths and quickly captures the *Daphnia* that it sees, swallowing one and spotting another simultaneously. In this state feeding rate is at its highest (19 to 20 a minute). When the shiftover to scotopic vision occurs, the animal resorts to an altogether different method. It stays in the bottom third of the tank, its body at a small angle with the bottom and "spots" the animal by its movement and shadow, then makes a dash upward, captures it and returns to the bottom of the tank again. The rate at which

it captures the prey depends on the light intensity, for as the intensity declines more and more there is greater difficulty in "spotting" any movement or silhouette. But as long as the intensity exceeds the rod threshold, some amount of feeding is feasible, but once the intensity falls below the rod threshold, feeding or capturing the prey by visual means stops altogether and whatever prey capturing occurs after this is due to the employment of some other sensory perception. In the case of the Pacific salmon, the rate of capture of prey in a completely dark room was found to be often 0 and rarely one or two in five minutes.

The positions of the pigment and cones and the rates of feeding at the intensities between rod and cone thresholds obey the Weber-Fechner Law (Figs. 23, 24 and 25).

In the following pages the positions of retinal pigment and cones as well as the feeding rates under different light intensities (in the case of late fry and smolts) of the Pacific salmon will be described. The intensities at which schools dispersed (in the case of the late fry only) will also be given. The data for each stage have been tabulated (Tables XII, XIII and XIV) and those for all the species studied summarised diagrammatically (Fig. 27), together with values of various light intensities in nature. The results of previous investigations with fish have also been presented (Table XV) for comparison.

1. Alevins (Two or three weeks after hatching - Fig. 23 and Table XII).

Only sockeye and chum alevins were used. The alevins used were not newly hatched as were those in the adaptation experiments but about two weeks older, some almost approaching the emerging stage. These showed notable positional changes of visual cell layers under different light conditions.

No differences were observed in the reactions of the retinal pigment and cones to different light intensities between the alevins that were kept in darkness and those that were kept in light, for four days, prior to the experiment (Figs. 23, 26 and Table XII. The pigment of the sockeye was fully expanded

Figure 23. The thicknesses of pigment and cones of sockeye and chum alevins in various light-intensities. (Light) and (Dark) refer to the fish that were kept under light or dark, respectively for three days before exposing them to the various light intensities (see text).

● Pigment

○ Cones

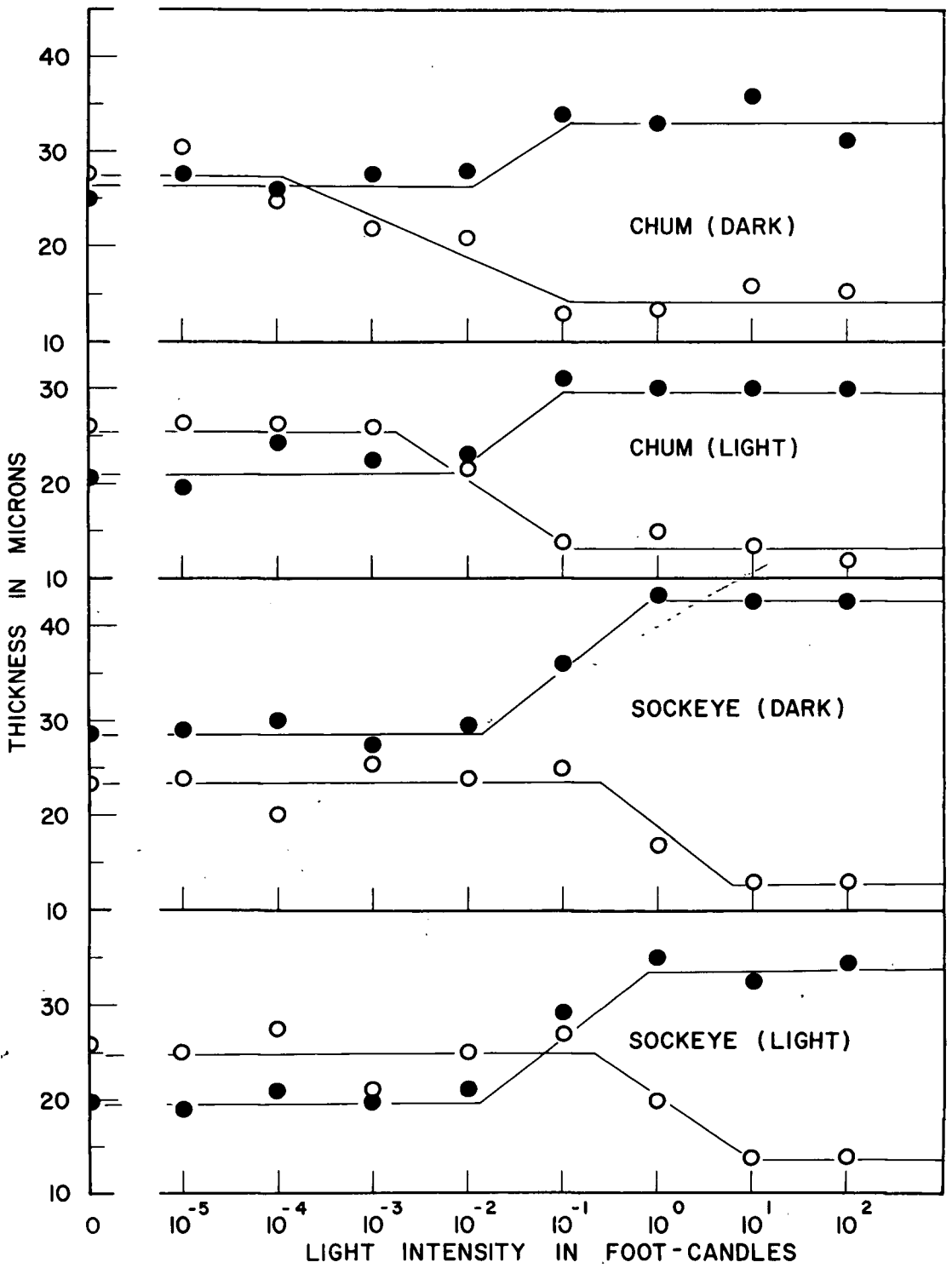

TABLE XII - Intensities at which pigment and cones start dark-adapting and become fully dark-adapted in the case of sockeye and chum alevins. One batch of each were held in light and another each in dark, for three days before exposure to different intensities. See Figs. 23 and 26.

Species	Intensity (ft-c.) at which fully light adapted		Intensity (ft-c.) at which fully dark adapted	
	Pigment	Cones	Pigment	Cones
Sockeye (held in light)	10^0	10^1	10^{-2}	10^{-1}
Sockeye (held in dark)	10^0	10^1	10^{-2}	10^{-1}
Chum (held in light)	10^{-1}	10^{-1}	10^{-2}	10^{-3}
Chum (held in dark)	10^{-1}	10^{-1}	10^{-2}	10^{-3}

until the intensity fell below 10^0 ft-c., and was fully contracted at intensities below 10^{-2} ft-c. The chum pigment seemed to have a lower threshold for the commencement of contraction (10^{-1} ft-c.), and was seen to be fully contracted at intensities of 10^{-2} ft-c., or lower.

The cones of both sockeye and chum were maximally expanded until the intensity decreased below 10^{-2} ft-c. The cones of the former were fully contracted at 10^{-1} ft-c., or lower, while those of the latter did not do so until the intensity fell below 10^{-3} ft-c., or lower.

2. Late fry (Figs. 24, 26 and Table XIII)

The pigment layer of all species, except sockeye, remains fully expanded until the intensity of light falls below 10^0 ft-c. That of sockeye starts contracting when the intensity falls below 10^1 ft-c. Maximal contraction of the pigment occurs at various intensities in the different species (Fig. 24 and Table XIII). Here the two extremes seem to be coho (10^{-3} ft-c.) and chum (10^{-1} ft-c.).

The cones of all species except coho do not start expanding (dark-adapting) unless the light intensity decreases below 10^0 ft-c. (cone threshold). This intensity is lower (10^{-1} ft-c.) in the case of coho (Fig. 26 and Table XIII). The cones are maximally expanded at 10^{-1} ft-c., in the case of pink and chum, while in the sockeye this occurs at 10^{-2} ft-c., and at 10^{-3} ft-c. in the case of the coho.

The feeding rates under the different light intensities studied show a correlation with the state of adaptation of the cones (Fig. 24 and Table XIII). Changes in feeding behaviour, when the light intensity falls below the cone threshold, are similar in all the species. When vision changes from photopic to scotopic, the animals stay in the bottom third of the tank and capture their prey by "spotting" their movements and silhouettes. It appears from these experiments that the cones of coho have the lowest threshold (10^{-1} ft-c.), while the others have a higher threshold (10^0 ft-c.).

Figure 24. The thicknesses of pigment and cone layers and the feeding rates of late fry belonging to the different species under various light intensities.

- Pigment
- Cones
- △ Feeding Rate

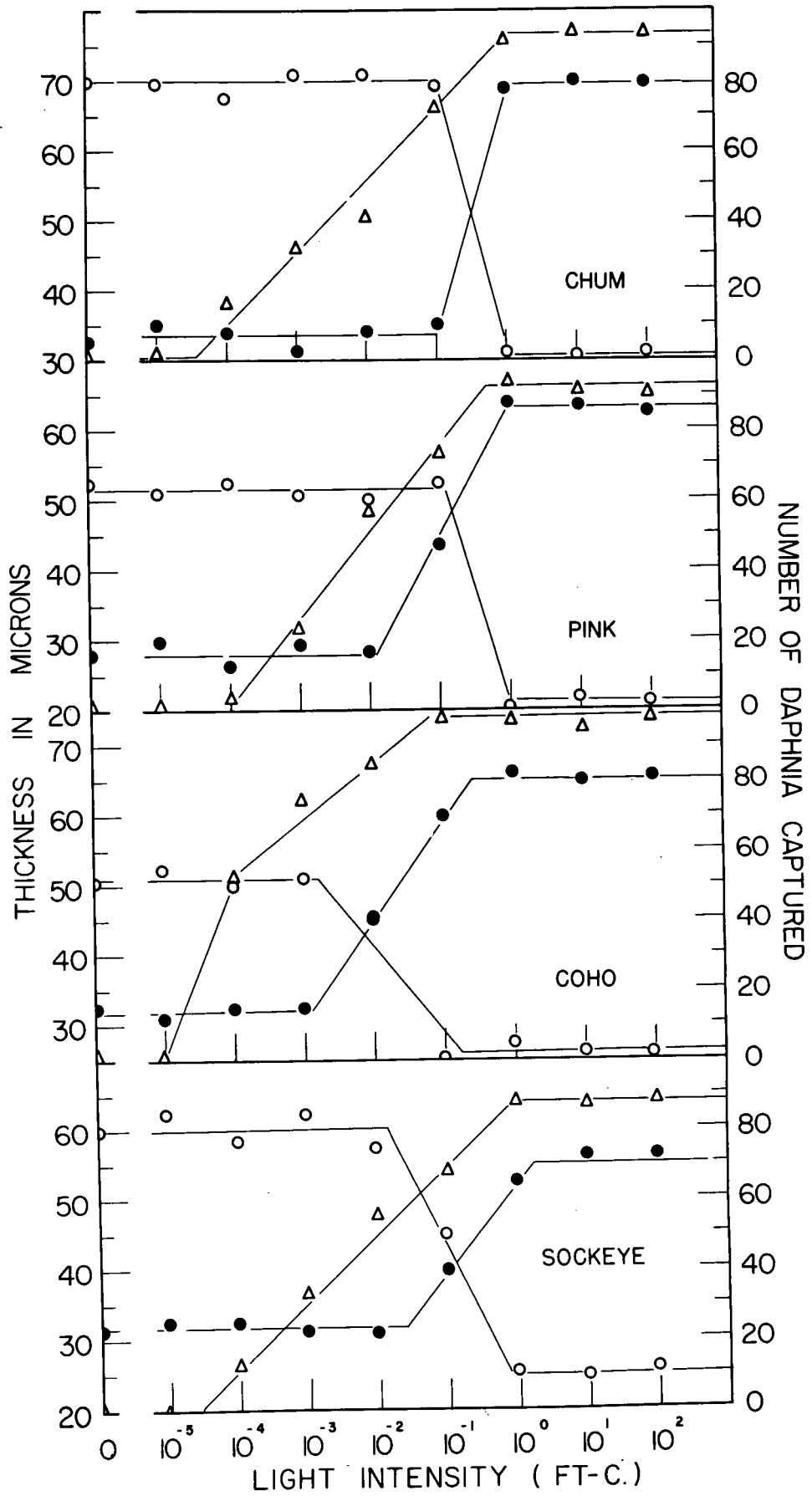

TABLE XIII - Intensities at which pigment and cones are light and dark-adapted, feeding is at its maximum or stops, and schools disperse in the late fry. See Figs. 24 and 25.

Species	Fully Light-adapted at ft-c.		Fully Dark-adapted at ft-c.		Cone Threshold ft-c.	Feeding Stops at ft-c.	Rod Threshold ft-c.
	Pigment	Cones	Pigment	Cones			
Sockeye	10^1	10^0	10^{-2}	10^{-2}	10^0	10^{-5}	10^{-4}
Coho	10^0	10^{-1}	10^{-3}	10^{-3}	10^{-1}	10^{-5}	10^{-4}
Pink	10^0	10^0	10^{-2}	10^{-1}	10^0	10^{-5}	10^{-4}
Chum	10^0	10^0	10^{-1}	10^{-1}	10^0	10^{-5}	10^{-4}

No feeding occurs at intensities of 10^{-5} ft-c. or lower. The rods of all the species studied have the same threshold (10^{-4} ft-c.).

The observations on the feeding rates and changes in feeding behaviour at different light intensities agree with those made with coho fry in an earlier investigation (Ali, 1957).

3. Smolts (Figs. 25, 26 and Table XIV)

The pigment of the sockeye smolt, like that of the sockeye late fry, does not commence contracting until the light intensity decreases below 10^1 ft-c., which is higher than the minimum intensity at which the coho pigment is fully expanded (10^0 ft-c.). As in sockeye, the coho smolts also show similarity with the fry. The retinal pigment layer of sockeye is maximally contracted at a lower light intensity (10^{-4} ft-c.) than that at which the coho pigment maximally contracts (10^{-2} ft-c.).

The cones of both sockeye and coho smolts do not commence their migration distally unless the light intensity falls below 10^{-1} ft-c. (Figs. 25, 26 and Table XIV). However, the maximum intensities of light at which they are fully expanded (dark-adapted) are different. They are 10^{-2} ft-c. (sockeye) and 10^{-3} ft-c. (coho).

In the case of the smolts also, feeding rates show agreement with the state of adaptation of the cones (Fig. 25). The change in the mode of capture of the prey when light intensity falls below the cone threshold is also the same as in the fry, described above.

The cone (10^{-1} ft-c.) and rod (10^{-4} ft-c.) thresholds, the intensity at which feeding by visual means stops (10^{-5} ft-c.) are the same in both the sockeye and coho smolts (Figs. 26, 28 and Table XIV).

In all cases, the pigment and cone layers at light intensities lower than their thresholds showed semi-contracted and semi-expanded stages respectively, with the exception of the pigment and cone layers of the late chum fry, the cones of the pink fry and sockeye smolts. This is perhaps understandable in the case of the pigment layer for its function seems to be to

TABLE XIV- Intensities at which pigment and cones are light-adapted and dark-adapted, feeding is at its maximum or stops, and cone and rod thresholds in the smolts. See Figs. 26 and 27.

Species	Fully Light-adapted at ft-c.		Fully Dark-adapted at ft-c.		Cone Threshold ft-c.	Feeding Stops at ft-c.	Rod Threshold ft-c.
	Pigment	Cones	Pigment	Cones			
Sockeye	10^1	10^{-1}	10^{-4}	10^{-2}	10^{-1}	10^{-5}	10^{-1}
Coho	10^0	10^{-1}	10^{-2}	10^{-3}	10^{-1}	10^{-5}	10^{-4}

Figure 25. The thicknesses of pigment and cone layers and the feeding rates of sockeye and coho smolts under various light intensities.

- Pigment
- Cones
- △ Feeding Rate

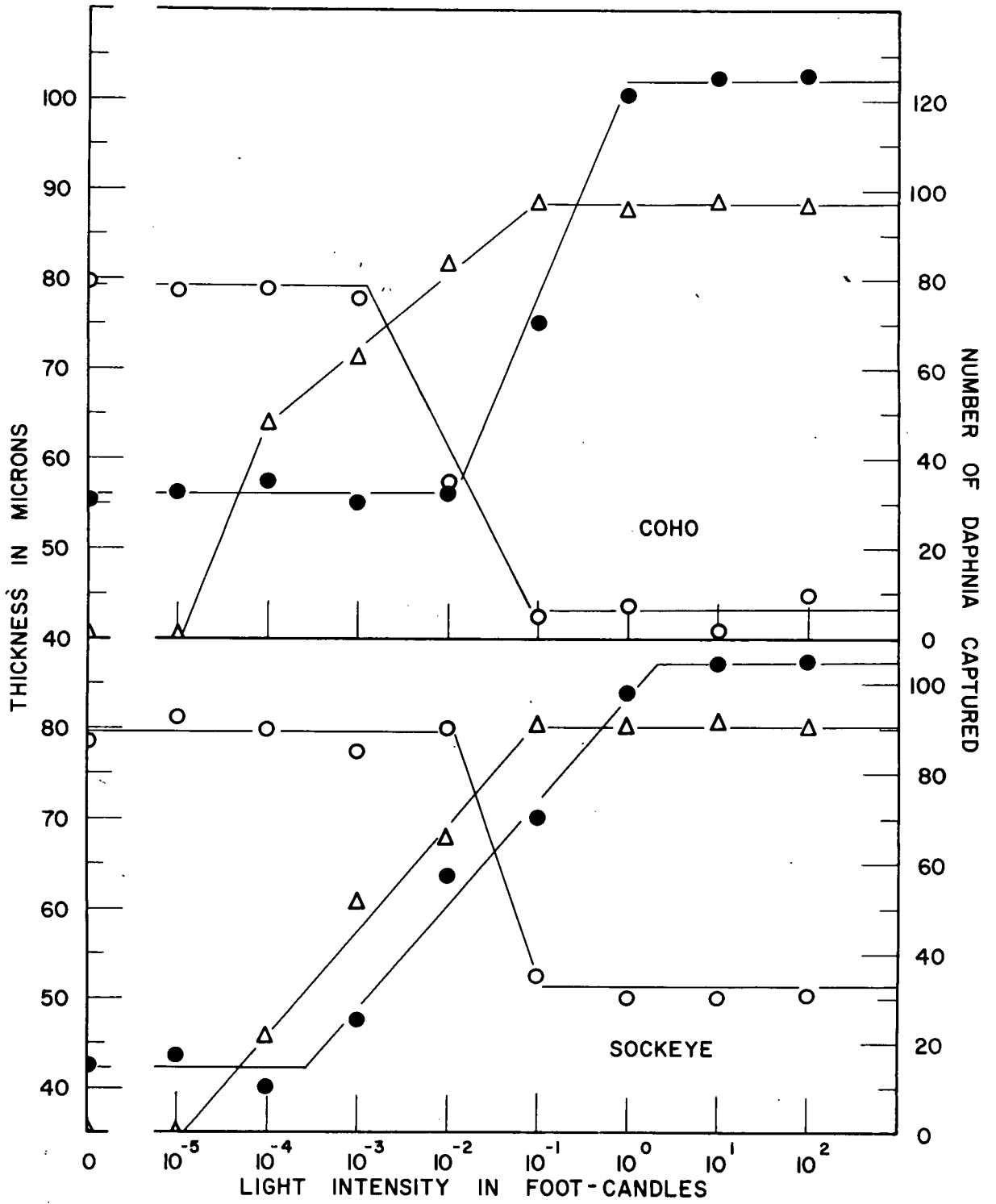

control, by expansion or contraction, the amount of light absorbed inside the optic cup, but one would assume that the cones would stay light-adapted as long as the light intensity exceeds their thresholds and then when it decreases below the thresholds, they would dark-adapt. These intermediate stages seen in the case of cones perhaps suggest that they are not altogether useless at light intensities below their thresholds. The absence of intermediate states of contraction and expansion of pigment and cones respectively in the exceptions mentioned above may be due to the reason that the intermediate states occur at some light intensity or intensities between the two intensities at which they were fully light-adapted and dark-adapted. On the other hand, this may not be the case, but may be characteristic of these particular stages. Further investigation alone can answer this.

D. State of the Retinal Pigment and Cone Layers
Under Constant Light or Dark

If the positions of the pigment and cone layers were to exhibit a diurnal rhythm, they would ^{not} present the appearance of completely dark-adapted states during the day even if the fish were kept in constant dark. On the other hand if there were a diurnal rhythm in their positional changes, they would not be fully light-adapted during the night even if the fish were maintained in constant light. In general, according to previous workers (Welsh and Osborn, 1937; Wigger, 1941; Arey and Mundt, 1941) diurnal rhythm is seen only in dark or is more pronounced in dark than under constant light. In instances where diurnal rhythm is observed it is more marked on the first day and less so on the second and eventually disappearing altogether. The period of its persistence varies.

The retinal pigment and cones of animals that do not possess a diurnal rhythm in their positions will always be light-adapted, when kept in light and sampled either during the day or night. Similarly, if they are kept in dark and sampled in daytime or night-time they will still present the appearance of being

Figure 26. Histogram showing the cone thresholds of the various stages of the different species.

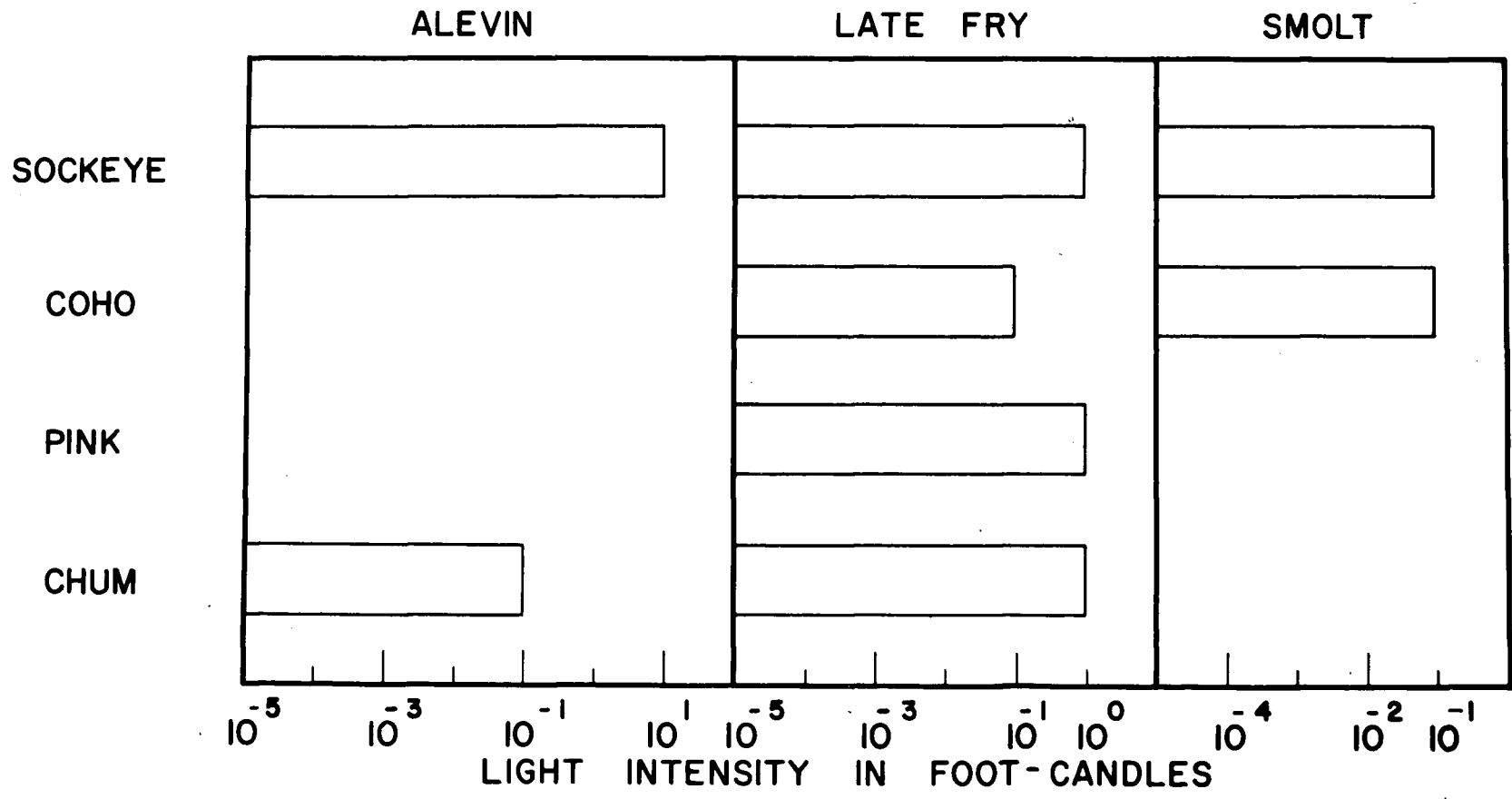

TABLE XV - Summary of the results of previous investigations using different fish in various light intensities.

Animal	Lowest Intensity at which in a Light-adapted State (ft-c.)	Highest Intensity at which in a Dark-adapted State (ft-c.)	Lowest Intensity at which Acuity at Maximum (ft-c.)	Highest Intensity at which Acuity Fails (ft-c.)	Reference
	Pigment Cones	Pigment Cones Rods			
<u>Phoxinus</u>		1.8×10^{-4}		7.4×10^{-4}	Brunner, 1934
<u>Lepomis</u>			3.7×10^{-2}		Wolf & Zerrahn-Wolf, 1935
<u>Ennecanthus</u>			29.57	3×10^{-7}	Crozier et al, 1936
<u>Lepomis</u>			100	5×10^{-7}	Kampa, 1953
<u>Salmo</u>				4.6×10^{-4}	Woodhead, 1957
<u>Phoxinus</u>	(School disperses at	2.2×10^{-3}	5.6×10^{-4}	6.5×10^{-5}	Jones, 1956
	to	3.2×10^{-3} ft-c.)			
<u>Lepomis</u>				9.3×10^{-7}	Grundfest, 1932
<u>Lepomis</u>				10^{-10}	Clarke, 1936
<u>Microcanthus</u>			12.1	4.6×10^{-1}	Yamanouchi, 1956

Continued on next page

TABLE XV - Summary of the results of previous investigations using different fish in various light intensities. Continued from page 80.

Animal	Lowest Intensity at which in a Light-adapted State (ft-c.)		Highest Intensity at which in a Dark-adapted State (ft-c.)		Lowest Intensity at which Acuity at Maximum (ft-c.)	Highest Intensity at which Acuity Fails (ft-c.)	References
	Pigment	Cones	Pigment	Cones	Rods		
<u>O. kisutch</u>					10^{-1}	10^{-4}	Ali, 1957
<u>Trachurus</u>	-.46	9.3×10^{-2}	2.8×10^{-2}	7.4×10^{-4})
<u>Carassius</u>		2.1×10^{-2}		7.4×10^{-4})
<u>Miagurnus</u>	6.5×10^{-2}	2.1×10^{-2}	1.9×10^{-4}	1.9×10^{-4}	7.4×10^{-4}) Kobayashi, 1957
<u>Lateolabrax</u>			{	3.7×10^{-3})
			{	(before midnight))
			{	9.3×10^{-4})
			{	(after midnight))
<u>Cyprinus</u>			{	4.6×10^{-5}) Tamura, 1957
			{	(before midnight))
			{	5.6×10^{-6})
			{	(after midnight))

Figure 27. Diagram summarising the results obtained under various light intensities, with some other responses of Oncorhynchus. Light intensities under natural conditions are also indicated for comparison.

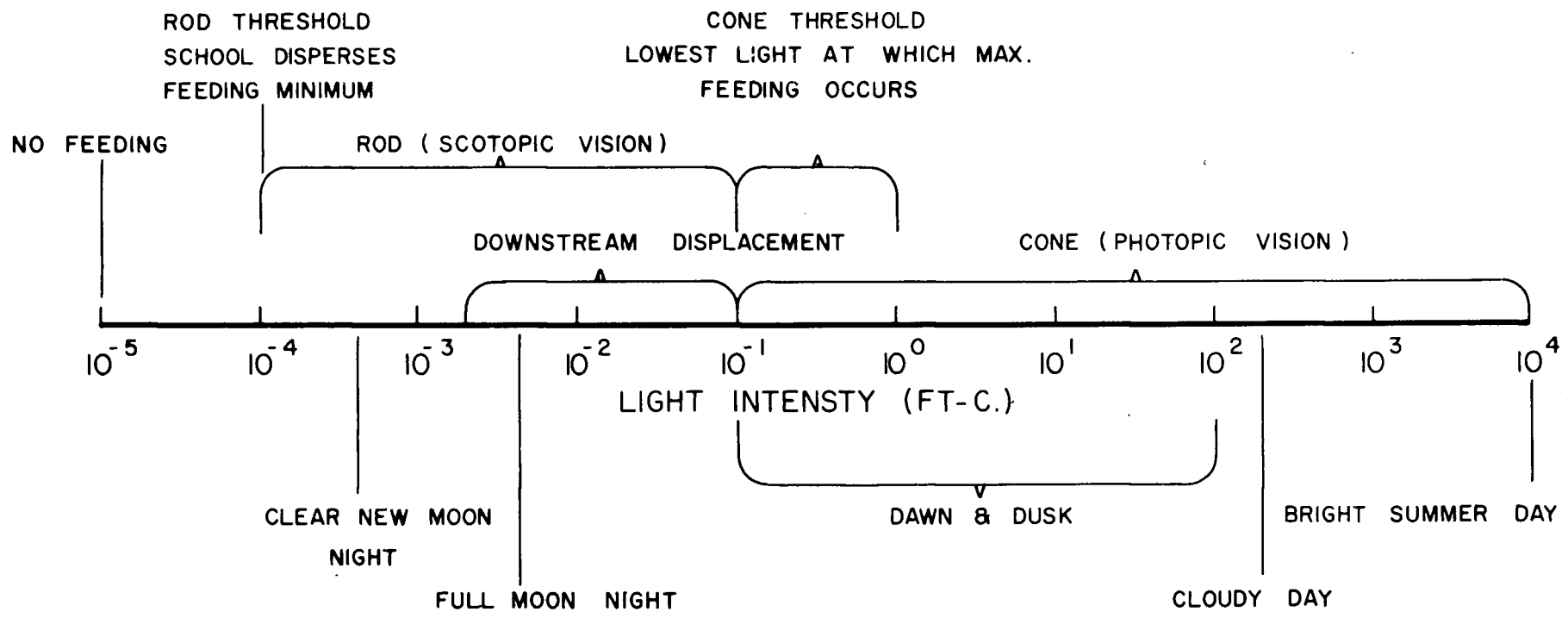

fully dark-adapted irrespective of the time at which they are sampled.

In the sockeye alevins, late fry, smolts; coho late fry; chum alevins and late fry which were subjected to constant darkness and light and sampled every three hours for 96 hours, no differences were observed between the positions taken by the retinal pigment of the animals fixed during the day and those fixed during the night. In all the histological preparations the retinae of animals subjected to constant light appeared fully light-adapted whether they were sampled during the day or during the night. Likewise, the retinae of animals kept in darkness were fully dark-adapted irrespective of the time of the day they were sampled. It does not appear that the pigment or cones have a diurnal rhythm or any rhythm indeed.

However, when the thicknesses were plotted against the time the animals were sampled, it was seen that except in a few cases the points of the graph did not present the appearance of lying in a straight line as is seen for example in the case of chum fry in dark, whose data are presented (Fig. 28). In most cases, although the pigment layer was fully light-adapted or dark-adapted, depending on whether the animal was held in light or dark, its thickness showed marked variation. This was less frequent in the case of the cones. The data for chum fry in light are presented (Fig. 28) as an example of an extreme case of variation. In addition, it also shows a tendency of the pigment layer to be slightly expanded in the nights of first two days. The reason for this, perhaps, is the building up of acid as has been described by von Studnitz (1933a) and Wigger (1937, 1941) in the case of the gold fish. On the other hand, it might be that constant light is a stress and as such disturbs the physiological balance in the animal's metabolism. Once the physiological balance is altered or upset, the changes in the secretion of hormones that control phenomena such as pigment dispersion or contraction could bring about changes in the thickness or position of pigment which are not diurnal but random, depending on the effect of endocrines. It has been

Figure 28. Thicknesses of pigment and cone layers of late chum fry at three hour intervals for 96 hours, under constant light or dark.

Pigment ●

Cones ○

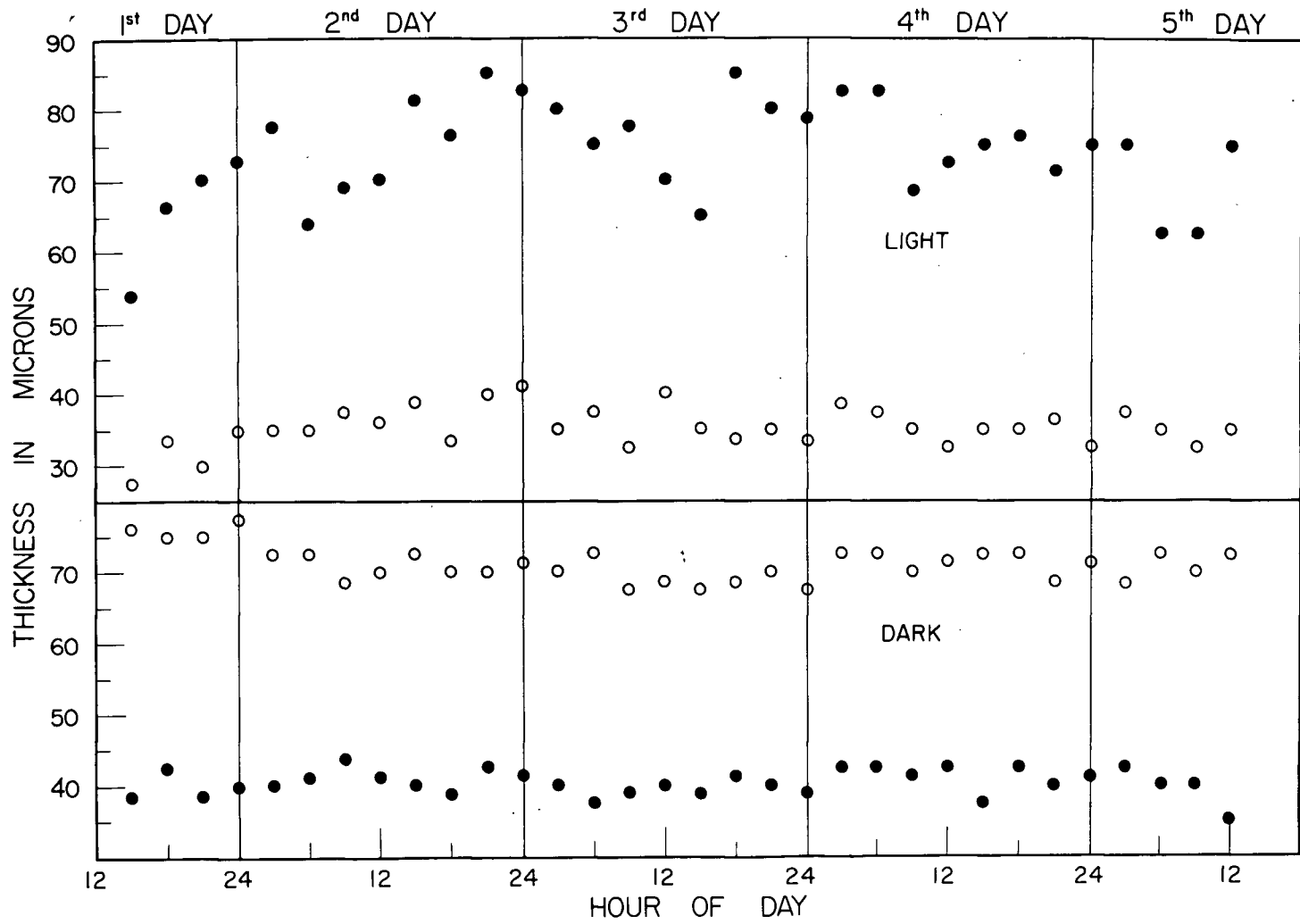

found that intermedin regulates the migration of retinal pigment in fishes (Vilter, 1942, 1946). In all other cases whether in constant light or constant darkness, the conditions varied between these two extremes. In general, the variation is greater in older animals such as smolts, most probably due to the greater thickness of their retinae.

Statistical analyses were carried out and no significant differences could be established either between the day data and night data or between the midnight data and the midday data or between the thicknesses of these layers of animals sampled during the first two days and those sampled during the last two days (3rd and 4th days).

It seems safe to conclude that in Oncorhynchus there is no diurnal rhythm in the positions of retinal pigment and cone layers and that the variations in the thicknesses of the pigment layer may be related to the action of intermedin.

V. DISCUSSION

A. Structure of the Oncorhynchus eye

The eye of the Pacific salmon possesses features such as the sclera, cornea, lens, iris and an inverted duplex retina with all the ten layers, that are characteristic of a typical vertebrate eye, including the human. However, since it is a teleost eye, it shows certain structural and functional features that are peculiar to most teleosts. These can be listed as the cup shaped, oval eye with its flattened anterior surface, proportionately larger cornea, spherical lens, retractor lentis, non-contractile iris, a "supplementary nutritive device" consisting of a falciform process, chorioid gland, accommodation (for distant or near vision) by shifting the lens axis, the presence of twin cones and the capacity of the visual cells and retinal pigment to undergo photomechanical changes.

1. Iris

Some teleosts such as the eel (von Stüdnitz, 1933), and some flounders and stargazers (Young, 1931, 1933) have a contractile iris. All the other teleosts that have been studied, have been observed to have a fixed pupil (Walls, 1942; Rochon-Duvigneaud, 1943, 1958).

2. Supplementary nutritive device

The mutually exclusive falciform process and hyaloid vessels form, what Walls (1942) refers to as the "supplementary nutritive device". The falciform process has its precursor in the holostean (Lepisosteus) eye but occurs prominently only among some teleosts. In the teleosts that do not possess it or possess it in a reduced form, hyaloid vessels occur between the nerve fibre layer and the internal limiting membrane (Walls, 1942). The same artery that supplies the falciform process supplies the hyaloid vessels in the latter forms.

The falciform process' connexion with the chorioid and the highly vascularised nature of its pigment layer suggest its function as a supplementary nutritive device.

3. Chorioid gland

Only those teleosts that possess a pseudobranch or false gill, found on the inner side of the operculum, possess the chorioid gland. An efferent artery supplies aerated blood to the chorioid gland after entering the eye in the vicinity of the optic nerve. In the forms that lack the pseudobranch (incidentally, most of these are small eyed forms such as the catfishes), the chorioid gland is also absent. Since the blood vessels from the chorioid gland branch further and enter the chorioid, it appears that the function is mainly nutritive. However, as Walls (1942) suggests it might also counteract fluctuations in the pressure of blood from the heart, so as to minimise mechanical disturbance of the retina.

4. Twin cones

Twin cones are a teleostean monopoly. Walls (1942) considers that these might have evolved from the holostean double cones by an equalisation of the two individuals forming the double cones. The structure of the unequal twin described in this paper (Fig.5) would appear to support this view. In the closely related genus Salmo, Verrier (1935) and McEwan (1938) have described similar unequal twin cones.

Of the three types of cones present, viz., single, twin and unequal twin cones, the last are rarely seen but occur mostly in the fundus and the surrounding regions.

B. Correlation between the arhythmic mode of life of Oncorhynchus and the structure of its retina

The heavily pigmented epithelial layer, three types of cones and the abundance of rods (Fig. 5) together with the ability of these visual elements to undergo remarkable photo-chemical changes, suggest that the Pacific salmon is, what Walls (1942) would call "arhythmic".

This is certainly borne out by the results obtained in this as well as an earlier (Ali, 1957) investigation. It has been shown (Figs. 24, 25, 27 and Tables XIII and XIV) that the juvenile Pacific salmon are capable of carrying on activities

such as feeding and schooling under widely different light conditions.

The presence of three types of cones and the complex neurological arrangement of the retina suggest that the Pacific salmon might be capable of colour vision.

C. Retinomotor (retinal photomechanical) responses

1. Phylogenetic occurrence

The vertebrate eye adapts itself for photopic (bright light) or scotopic (dim light -Dämmerungssehen) vision by shifting the position of its visual cells and retinal pigment (most teleosts) as shown in the several figures in this paper or by the constriction or dilation of its iris (mammals). The eel among the teleosts (von Studnitz, 1933a), anural amphibians, several reptiles and birds (Detwiler, 1943) employ both methods. Cyclostomes show neither retinal nor pupillary responses (Walls, 1928b, 1942). Elasmobranchs show no retinomotor responses but have a contractile iris (von Studnitz, 1933b). Diurnal ganoids (Amia) show retinal photomechanical responses but nocturnal forms (Acipenser) do not. Some dipnoans and cladistians possess a contractile iris but show no retinomotor response (Walls, 1942).

Teleosts as a group show extensive retinal photomechanical responses (Garten, 1907; Arey, 1915, 1928; Parker, 1932; Walls, 1942; Detwiler, 1943; von Studnitz, 1952). In some teleosts such as flounders and stargazers (Young, 1931, 1933) pupillary responses have been observed but information on whether or not their retinae are capable of retinomotor movements is not available.

Amphibians with the exception of caecillians show photomechanical changes in their retinae, particularly of the pigment and cone layers. Although, not much is known about the distribution of retinomotor responses among the reptiles, enough is known (Detwiler, 1943) to indicate that some of them do show a slight migration of visual cell and retinal pigment layers. Birds are capable of extensive retinomotor responses.

In some cases their pigment migration is so extensive that in the light-adapted state it extends down to the external limiting membrane. Mammals light or dark-adapt by a dilation or contraction respectively, of their iris and show no retinal photomechanical changes (Walls, 1928a).

Retinomotor responses are more primitive as compared with pupillary responses (Walls, 1942), but are more efficient, their only disadvantage being the slowness with which they occur. In fast moving forms with high visual acuity, such as the birds, this method of adaptation has been retained and the whole mechanism of adaptation perfected by the evolution of a contractile iris as well.

2. Ontogeny of retinomotor responses in Onchorhynchus

As has been shown in this paper (Figs. 6 to 9, 12, 18 to 21), retinal photomechanical changes occur neither in the embryos prior to hatching nor in the newly hatched alevins of any Oncorhynchus species. The situation changes as the alevins become older. Two or three weeks after hatching, the alevin with a comparatively small yolk sac shows retinomotor responses to different light conditions (Fig. 23 and Table XII). In the emerged fry, the ability of the retina to undergo extensive photomechanical changes (Figs. 6 to 9, 14, 18 to 21) and emergence from the gravel, with the consequent exposure to different light conditions, coincide. This ability is more marked in the late fry and is perfected in the smolts (Figs. 15 and 16).

Since no study of the ontogeny of photomechanical responses in other teleosts or in any other vertebrate group is available, it is not possible to state with certainty whether this situation is common to all teleosts or to other vertebrates whose retinae are capable of undergoing photomechanical changes. The development of the rat (Detwiler, 1932) and the guppy (Muller, 1952) retinae suggest that it is likely.

3. Inter-specific comparison of retinomotor responses of the species and stages of Oncorhynchus

Clemens (1953) wrote, "On the basis of morphological, physiological, life-history and behaviour studies to date, it appears that spring and coho salmon are related on the one hand, pink and chum on the other, and that sockeye occupy a position more less intermediate between the two pairs". Based on several years of study of the behaviour of juvenile Oncorhynchus, Hoar (1958) has come to the conclusion that the coho are the closest to the parental, trout-like type, while the pink and chum are the most specialised. Specific differences have been found among the juvenile Oncorhynchus in their reactions to light (Hoar et al, 1957). However, no differences in their ocular structure were found in this as well as an earlier investigation (Ali and Brett, 1958). Hence, it was of interest to note whether they showed any inter-specific differences in their retinomotor responses.

As has been shown in the results, the various species and stages studied did show differences in their rates of light or dark-adaptation and retinal responses to different light intensities. However, these differences are not consistent (Figs. 17, 22, and 26) and do not indicate inter-specific relationships.

D. Significance of retinomotor responses in the life of juvenile Oncorhynchus

1. Precedence of light sensitivity to retinomotor responses

It has been shown that the eyes of the newly hatched alevins are not capable of undergoing photomechanical responses. However, they are photosensitive as seen by their negative response to light. Hoar (1958) considers the tendency to hide under stones (as a result of photonegative response) to be their complete behaviour at this stage. The Oncorhynchus alevins become less photonegative and increasingly photopositive with age. This coincides with the greater development of the retinal elements resulting in their increased ability to respond to

light (Figs. 13 and 23), culminating in the photopositive emerged fry that is also capable of undergoing marked photomechanical changes (Figs. 6, 7, 8, 9, 14, 18, 19, 20, 21 and 22), and also possesses full visual acuity as shown by the feeding experiments (Figs. 11, 24).

The newly hatched demersal alevins of fresh-water fish are known to be photonegative (Buckland, 1863; Hein, 1906; White, 1915; Smith, 1916; Gray, 1928; Stuart, 1953; Woodhead, 1957). It is not known whether the retinae of these alevins are capable of undergoing photomechanical changes or not. In contrast to the demersal alevins of the fresh-water species, the pelagic larvae of marine fish that have been studied so far are all reported to be photopositive (Dannevig, 1932; Franz, 1909; Soleim, 1942; Tavolga, 1950; Buckmann et al, 1953). Again, it is not known whether their eyes show retinomotor responses.

2. Migratory behaviour

As Clemens (1951) remarked, "The migration of Pacific salmon is another excellent illustration of the delicate inter-relations between organisms and the environment; in other words, of the interplay between a physico-chemical organism and a physico-chemical environment". The downstream migration, which takes place at dusk is a combination of the fish's response to light and its individual behaviour pattern ((Hoar, 1953). It has been shown that the eyes of sockeye and coho smolts as well as pink and chum fry are in the process of dark-adapting at the time of the commencement of downstream migration (Ali and Brett, 1958).

Hoar (1953, 1958), Neave (1955) and McDonald (1956) have shown that as the light intensity decreases at dusk, the fry of the migrating species (sockeye, pink and chum) rise to the surface and either swim with the current or are displaced. The mechanism of downstream migration is similar in fry and smolts. The coho fry do not show the same marked increase in activity as the other species at dusk. Due to this, they ordinarily do not rise to the surface and become displaced at dusk. They are however, subject to some displacement,

particularly in times of high water (Hoar, 1958). The fact that the cone threshold of coho fry (10^{-1} ft-c.) is lower than that of the other species (Fig. 26) while their rate of dark-adaptation is very similar (Fig. 22), might be partly or wholly responsible for this difference in their behaviour. They will, in short, be able to see at lower light intensities.

Evidence has been presented in the present investigation to show that when the light intensity falls below the cone thresholds (10^{-1} to 10^0 ft-c.) the eyes of fry and smolts commence to dark-adapt (Fig. 24 and 25). It has also been shown that the process of dark-adaptation takes ordinarily (with the exception of emerged chum fry) 35 to 40 minutes in the case of fry and 40 to 50 minutes in the case of smolts (Fig. 22). In the face of this evidence, it is suggested that these fish commence migration as the light intensity begins to decrease rapidly and falls below the cone threshold. This may result in a state of partial night-blindness. At this stage the rate of decrease of light intensity in nature is very rapid and decreases from 1.0 ft-c. to 0.002 ft-c. in 30 minutes (Ali and Brett, 1958, Figs. 9, 10 and 11). Its rate is greater than the rate of dark-adaptation as found in this investigation. This leaves the animal in a semi-dark-adapted state which results in its losing its ability to maintain position with relation to some reference point and it swims with the current, or is displaced downstream.

Since the process of dark-adaptation takes 35 to 40 minutes for completion in the fry, those that have risen to the surface at the time of dusk are in a semi-dark-adapted state for 35 to 40 minutes and consequently, swim with the current or get displaced during this entire period. When the process of dark-adaptation is completed the light intensity at the surface of the water is well above the rod threshold (10^{-4} ft-c; Tables XIII and XIV) and the fry are able to see large objects such as rocks and use them as reference points and migration ceases or slows down considerably. This suggests that the states of adaptation of the eyes are responsible for the marked peak in the downstream migration of the juveniles at dusk. This peak

in migration lasts for a longer time in the case of sockeye smolts (Dr. W.A. Clemens, personal communication). This appears to be due to the process of dark-adaptation taking a longer time (50 minutes) in the case of sockeye smolts (Fig. 22).

This peak in the downstream migration of the Oncorhynchus juveniles may have survival value, especially in the case of smaller fry. As Hoar (1958) remarks, "When many small fish must face a fixed number of predators, the shorter and more precise the period of contact, the better will be their chances of survival". The slow rate of dark-adaptation coupled with the rapid decrease in light intensity, triggers their mass migration lasting for a brief period, with its obvious advantages.

Another point that warrants mention here is the fact that these migrations at dusk are related, not to the time of the day, but to the light intensity (McDonald, 1956). In other words, as the summer day gets longer and longer, the commencement of migration shifts to later times in the evening corresponding to the intensity of light. The absence of diurnal rhythm in the positions of pigment and cones, as shown in this investigation (Fig. 28), makes possible this response to light intensity, for, if there were a sharp diurnal rhythm in the positions of the visual cells and pigment layer, the animal would possess an eye in a particular state of adaptation irrespective of the intensity of light available. This would result in its coming up to the surface and swimming or being displaced with the current at the same time every day.

It would appear that in guiding juvenile downstream migrants around barriers such as dams, using visual stimuli (e.g., illuminated screens), the fact that the eye of the migrating fish is in a semi or fully dark-adapted state (Ali and Brett, 1958) and that it takes 10-20 minutes for it to light-adapt fully (Fig. 17) may be important. Unless the eye is in a light-adapted state, visual acuity, so necessary for the animal to be able to follow the moving screen, is not at its best as shown by the feeding experiments conducted in the

present investigation (Fig. 11, also compare Fig. 17).

3. Schooling

That sight is the primary requisite in the formation and maintenance of fish schools has been established (Keenleyside, 1955; Hoar, 1958), and this investigation presents more evidence to support this. It has been shown in the results that schools of juvenile Oncorhynchus disperse in total darkness and in light intensities lower than the rod threshold (10^{-4} ft-c. Table XIII). Pink, chum and sockeye fry, which are known to school readily (Hoar, 1958) form schools ten to fifteen minutes after dark-adapted fish are exposed to light (Fig. 10). The coho, on the other hand, school less readily as shown by the longer time they take to school and the fewer animals that participate in this process (Fig. 10). The time taken by the dark-adapted animals on exposure to light, to school is less than the time taken for full light-adaptation (compare Figs. 10 and 17). From this it would appear that full acuity of vision is not necessary to recognise and join another fish of the same species to form a school. This is supported by the fact that schools persist in dim light when the eyes are adapted for scotopic vision. Once formed, a school stays intact (other conditions remaining the same) until the light intensity falls below the threshold for rods, when even the shapes of large objects are not recognisable.

4. Feeding

As Hoar (1958) observed, "The Pacific salmon is basically a surface feeding fish, depending on its eyes for the location and capture of its food". This has been well exemplified by the results obtained in this as well as an earlier investigation (Ali, 1957). Active feeding stops in the dark, save for the occasional, chance capture of prey. In feeding experiments, in which live prey are used, the behaviour of the prey under different light intensities will affect the results significantly. However, in the case of *Daphnia*, it has been shown (Harris and Wolf, 1955) and also noticed during the course of the present investigation that on exposure to total

darkness, the Daphnia will sink to the bottom only after ten to fifteen minutes, whereas experiments in this investigation did not last over five minutes.

It has been shown that feeding does not occur when the light intensity is lower than the rod threshold (Figs. 24 and 25). It occurs at higher intensities but between the rod and cone thresholds (scotopic vision), is proportional to the logarithm of the light intensity (Weber-Fechner Law). When light intensity increases to cone threshold or higher, it reaches its maximum. Whether very high intensities reduce feeding rates is a matter of conjecture, but intensities as high as 63×10^2 ft-c., did not affect maximum feeding in coho fry (Ali, 1957).

The change in the mode of capture of the prey as the intensity falls below the cone threshold is interesting and indicates the inability of the rods to resolve as the cones do. That the visual acuity is lost in the scotopic visual field of the animal is shown by the change to the "silhouette method" of feeding whereby the animal makes use of the sensitivity of rods and "spots" the shadow of the prey against the brighter background. With decreasing light intensity the difference between the shadow and background diminished, making the location of prey more and more difficult. This accounts for the reduction in feeding rates, in proportion to the logarithm of the light intensity (Figs. 24 and 25). When the light intensity falls below the rod threshold, the shadow of the prey cannot be distinguished from the background, by the animal, resulting in its inability to spot the prey, and feeding stops.

VI. CONCLUSIONS

1. The structure of the Oncorhynchus eye is typical of vertebrate and teleost eyes. It is very similar to the Salmo eye described in the literature.
2. The iris of the Oncorhynchus is immobile.
3. The Oncorhynchus eye has a chorioid gland and a falciform process.
4. The neurological arrangement of the Oncorhynchus retina is similar to that of the primate retina.
5. The eyes of the late embryos are not fully developed histologically and physiologically and are not capable of retinomotor responses.
6. The eyes of the alevins are also not fully developed, but show some response to light. Their ability to undergo photomechanical changes increases with age.
7. As the animals become older, they show a general trend in shortening of the time required for light-adaptation.
8. Dark-adaptation takes a longer time than does light-adaptation.
9. The time taken for dark-adaptation shows a tendency to increase with age.
10. The pigment layers of all the fish studied, except that of the late pink fry, have a latent period before the commencement of contraction in the dark.
11. The latent period is longer in older sockeye and coho. It does not change with age in the chum salmon. In the case of the pink it is very short (5 minutes) in the emerged fry and is absent in the late fry.
12. The four species of Pacific salmon studied show differences in their retinal and behavioural responses to light.
13. In all cases, the state of the cones and the ability to capture maximum number of *Daphnia* are correlated.

14. The sockeye show a lowering of the cones thresholds with age; in the coho there are no differences among the early life history stages, while the chum fry have a higher cone threshold than do the alevins. Only the fry of pink were studied.
15. The rod threshold (10^{-4} ft-c.) is the same in all species and stages.
16. The feeding rates and thicknesses of the pigment and cone layers obey the Weber-Fechner Law in the intensities between the rod and cone thresholds.
17. Under constant light or constant dar, there is no diurnal rhythm in the positions of the pigment and cone layers of the Pacific salmon.
18. Based on this research it is suggested that the downstream migration of juvenile Pacific salmon occurs as a result of their eyes being in a semi-dark-adapted state for a short period at dusk, due to the rapid decrease in the incident light intensity and the relatively slower rate of dark-adaptation. This results in the fish losing their reference points and swimming with the current or being displaced downstream.

VII. LITERATURE CITED

- Ali ibn Isa 940-1010. Tadhkirat al-Kahhalin (Oculist's memorandum book). Latin Ed. in P. Pansier, "Collectio ophthalmologica veterum auctorum", Vol. 3, J.B. Bailliere & Fils, Paris, 1903. (From Polyak, 1941).
- Ali, M.A. 1956. Studies on the retina of the Pacific salmon. Proc. British Columbia Academy of Sciences. Tenth Sci. Conference, p. 6 (Abstract).
- Ali, M.A. 1957. Rate of feeding in coho (Oncorhynchus kisutch) under different light intensities. Proc. British Columbia Academy of Sciences. Eleventh Sci. Conference, p. 14 (Abstract).
- Ali, M.A. and Brett, J.R. 1958. The structure and photomechanical responses of the Pacific salmon retina. J. Fish. Res. Bd. Canada, 15: (in press).
- Arey, L.B. 1915. The occurrence and the significance of photo-mechanical changes in the vertebrate retina - an historical survey. J. comp. Neurol., 25: 535-554.
- Arey, L.B. 1916. The movements in the visual cells and retinal pigment of the lower vertebrates. J. comp. Neurol., 26: 121-201.
- Arey, L.B. 1919. A retinal mechanism of efficient vision. J. comp. Neurol., 30: 343-354.
- Arey, L.B. 1928. Visual cells and retinal pigment. "Special Cytology", Vol. 2, Section 25, 887-926. E.V. Cowdry, Editor. Paul B. Hoeber Inc., New York.
- Arey, L.B. and Mundt, G.H. 1941. A persistent diurnal rhythm in visual cones. Anat. Rec., 79 (Supp):5.
- Boll, F. 1877. Zur anatomie und physiologie der retina. Arch. Anat. Physiol., 4: 783-787.
- Brown, F.A. 1936. Light intensity and melanophore response in the minnow, Ericymba buccata Cope. Biol. Bull. Woods Hole, 70: 8-15.
- Brunner, Gertrud, 1934. Uber die Sehschärfe der Elritze (Phoxinus laevis) bei verschiedenen Helligkeiten. Z. vergl. Physiol., 21: 296-316.
- Buckland, F.T. 1863. Fish hatching. London.
- Buckmann, A., Harder, W.S. and Hempel, G. 1953. Unsere Beobachtungen am Hering (Clupea harengus L). Kurze Mitt. a.d. Fischereibiologie abt. d. Max-Planck-Instituts, Wilhelmshaven, 3: 22-42.

- Buddenbrock, W. von, 1952. Vergleichende Physiologie Bd.1. Sinnesphysiologie. Verlag Birkhäuser, Basel.
- Chiarini, P. 1904. Changements morphologiques que l'on observe dans la rétine des vertébrés par l'action de la lumière et de l'obscurité. Première Partie. La rétine des poissons et des amphibes. Arch. ital. Biol., 42: 303-322.
- Clemens, W.A. 1951. On the migration of Pacific salmon (Oncorhynchus). Trans. Roy. Soc. Can., 3rd Ser. 45 (Sec. V): 9-17.
- Clemens, W.A. 1953. On some fundamental problems in the biology of Pacific salmon. Trans. Roy. Soc. Can. 3rd Ser. 47 (Sec. V): 1-13.
- Crozier, W.J., Wolf, E. and Zerrahn-Wolf, G. 1936. On critical frequency and critical illumination for reaction to flickering light. J. gen. Physiol., 20: 211-228.
- Dannevig, A. 1932. Flødevigens Utklekningsansalt 1882-1932. IV Torsk, Utklekning og undersøkelser. Arsberetn, ved. Norges. Fisk. 4: 17-30.
- Detwiler, S.R. 1932. Experimental observations upon the developing rat retina. J. comp. Neurol., 37: 481.
- Detwiler, S.R. 1943. Vertebrate photoreceptors. MacMillan Co., New York.
- Eigenmann, C.H. and Schafer, C.D. 1900. The mosaic of single and twin cones in the retina of fishes. Amer. Nat., 34: 109-118.
- Franz, V. 1909. Einige Versuche zur biologie der fischlarven. Int. Rev. Hydrobiol., 2: 557-579.
- Franz, V. 1913. Sehorgan. Oppel's Lehrbuch der vergleichende mikroskopische Anatomie der Wirbeltiere. G. Fisher, Jena.
- Garten, S. 1907. Die Veränderungen der Netzhaut durch Licht. Von Graefe-Saemisch Handbuch der Augenheilkunde. Partl, Vol. 3, Cap. 12. 2nd Edn.
- Granit, R. 1947. Sensory mechanisms of the retina. Oxford University Press, London.
- Granit, R. 1955. Receptors and sensory perception. Yale University Press, New Haven.

- Gray, J. 1928. The growth of fish. II. The growth rate of the embryo of Salmo fario. J. exp. Biol., 6: 110-124.
- Grundfest, H. 1932. The sensibility of the sun-fish, Lepomis, to monochromatic radiation of low intensities. J. gen., Physiol. 15: 307-328.
- Harris, J.E. and Wolfe, Ursula K. 1955. A laboratory study of vertical migration. Proc. Roy. Soc. London, Ser. B, 144: 329-354.
- Hein, W. 1906. Zur Biologie der Forellenbrut I. Versuche über das Nahrungsbedürfnis der Bachforellenbrut im Bruttrug und im künstlichen Brutbett. Allg. Fisch. Ztg., 31: 239-243.
- Hoar, W.S. 1951. The behaviour of chum, pink and coho salmon in relation to their seaward migration. J. Fish. Res. Bd. Canada, 8: 241-263.
- Hoar, W.S. 1953. Control and timing of fish migration. Biol. Rev. 28: 437-452.
- Hoar, W.S. 1954. The behaviour of juvenile Pacific salmon, with particular reference to the sockeye (Oncorhynchus nerka). J. Fish. Res. Bd. Canada, 11: 69-97.
- Hoar, W.S. 1956. The behaviour of migrating pink and chum salmon fry. J. Fish. Res. Bd. Canada, 13: 309-325.
- Hoar, W.S. 1958. The evolution of migratory behaviour among juvenile salmon of the genus Oncorhynchus. J. Fish. Res. Bd. Canada, 15: (in press).
- Hoar, W.S., Keenleyside, M.H.A. and Goodall, R.G. 1957. Reactions of juvenile Pacific salmon to light. J. Fish. Res. Bd. Canada, 14: 815-830.
- Hunain ibn Ishak 806-877. The book of ten treatises on the eye. Editor M. Meyerhof, Government Press, Cairo, Egypt, 1928.
- Jones, F.R.H. 1956. The behaviour of minnows in relation to light intensity. J. exp. Biol., 33: 271-281.
- Kampa, Elizabeth (Mrs. B.P. Boden) 1953. Effects of vitamin A supplementation and deprivation on visual sensitivity, rhodopsin concentration, and retinal histology of a marine teleost, Gillichthys mirabilis. Bull. Scripps Instn. Oceanogr., 6: 199-224.
- Kobayashi, H. 1957. Notes on retino-motor phenomena in some fishes under the various light conditions. J. Shimonoseki Coll. Fish., 7: 169-177.

- Kühne, W. 1877. Über das Vorkommen des Sehpurpurs. Centrabl. med. Wiss., 15: 257-272.
- McDonald, J.G. 1956. The seasonal and diurnal movements of some Pacific salmon fry with particular reference to the sockeye (Oncorhynchus nerka). M.A. Thesis. University of British Columbia.
- McEwan, Mary R. 1938. A comparison of the retina of the mormyrids with that of various other teleosts. Acta. Zool., 19: 427-465.
- Müller, Hans 1952. Bau und Wachstum der Netzhaut des Guppy (Lebistes reticulatus). Zool. Jahrb., 63: 275-324.
- Neave, F. 1955. Notes on the sea-ward migration of the pink and chum salmon fry. J. Fish. Res. Bd. Canada, 12: 369-374.
- Parker, G.H. 1932. The movements of the retinal pigment. Ergebn. Biol., 9: 239-291.
- Pergens, E. 1896. Action de la lumière sur la rétine. Ann. Soc. sci. méd. nat. Bruxelles, 5: 389-421.
- Polyak, S.L. 1941. The retina. The University of Chicago Press, Chicago.
- Polyak, S.L. 1957. The vertebrate visual system. The University of Chicago Press, Chicago.
- Rochon-Duvigneaud, A. 1943. Les Yeux et la Vision des Vertébrés. Masson et cie., Paris.
- Rochon-Duvigneaud, A. 1958. L'oeil et la vision in Traité de Zoologie, Tome XIII, Fascicule . P.P. Grasse, Editor. Masson etcie., Paris.
- Sasruta, c.1,000 B.C. Samhita Uttara Tantra. English translation: N.K. Bidhyadhar, 1939, Arch. Ophthal., 22: 550-572.
- Smith, E.V. 1916. Effect of light on the development of young salmon. Pub. Puget Sd. Mar. biol. Sta., 1: 89-107.
- Soleim, P.A. 1942. Årsaker til rike og fattige åranger av sild. Fisk. Skr. Havrindersøk. 7: 22-24.
- Stuart, T.A. 1953. Spawning migration, reproduction and young stages of Loch trout (Salmo trutta L). Sci. Invest. Fish. Scotl. 5: 1-39.

- Studnitz, G. von 1933a. Beitrage zur Adaptation der Teleosteer. (Studien zur vergleichenden Physiologie der Iris II.) Z. vergl. Physiol., 18: 307-338.
- Studnitz, G. von 1933b. Studien zur vergleichenden Physiologie der Iris. III selachier. Z. vergl. Physiol., 19: 619-631.
- Studnitz, G. von 1952. Physiologie des Sehens (Retinale Primärprozesse). Akademische Verlagsgesellschaft, Leipzig. 2nd Edition.
- Tamura, T. 1957. On the relation between the intensity of illumination and the shifting of cones in the fish retina. Bull. Jap. Soc. sci. Fish., 22: 742-746 (In Japanese, with English summary).
- Tavloga, W.N. 1950. Development of the gobiid fish, Bathygobius soporator. J. Morph., 87: 467-492.
- Verrier, Marie Louise, 1935. Les variations morphologique de le rétine et leurs conséquences physiologique. A propos de la rétine d'une musaraigne (Crocidura mimula Miller). Ann. sci. nat. Paris, 18: 205-216.
- Vilter, V. 1942. Régulation sympathico-hypophysaire de migration pigmentaires dans la rétine de l'anguille (Anguilla vulgaris L). Arch. Phys. biol., 16 (Suppl): 6-8.
- Vilter, V. 1946. Déterminisme intrinsèque de migrations pigmentaires dans la rétine. C.R. Soc. biol. Paris, 140: 277-278.
- Walls, G.L. 1928a. The photochemical changes in the retina of mammals. Science 67: 655.
- Walls, G.L. 1928b. An experimental study of the retina of the brook lamprey, etc. J. comp. Neurol., 46: 465-473.
- Walls, G.L. 1942. The vertebrate eye and its adaptive radiation. Cranbrook Institute of Science, Bull. 19, Bloomfield Hills, Michigan.
- Welch, J.H. and Osborn, C.M. 1937. Diurnal changes in the retina of the catfish, Ameiurus nebulosus. J. comp. Neurol., 66: 349-359.
- White, G.M. 1915. The behaviour of brook trout embryos from the time of hatching to the absorption of the yolk sac. J. Animal Behaviour, 5: 44-60.

- Wigger, H. 1937. Versuche zur Kausalanalyse der retinomotorischen Erscheinungen. Pflügers Arch., 239: 215-246.
- Wigger, H. 1941. Diskontinuität und Tagesrhythmik in der Dunkelwanderung Retinaler Elements. Z. vergl. Physiol., 28: 421-427.
- Wolf, E. and Zerrahn-Wolf, G. 1935. Threshold intensity of illumination and flicker frequency for the eye of the sunfish. J. gen. Physiol., 19: 495-502.
- Woodhead, P.M.J. 1956. The behaviour of minnows (Phoxinus phoxinus) in a light gradient. J. exp. Biol., 33: 257-270.
- Woodhead, P.M.J. 1957. Reactions of salmonid larvae to light. J. exp. Biol., 34: 402-417.
- Wunder, W. 1936. Physiologie der Süßwasserfische Mitteleuropas. E. Schweizerbart's Publishing House, Stuttgart.
- Yamanouchi, T. 1956. The visual acuity of the coral fish, Microcanthus strigatus (Cuvier & Valenciennes). Pub. Seto. mar. Biol. Lab., 5: 133-156.
- Young, J.Z. 1931. The pupillary mechanism of the teleostean fish Uranoscopus scaber. Proc. Roy. Soc. London, Ser. B, 107: 464-485.
- Young, J.Z. 1933. Comparative studies on the physiology of the iris. II Uranoscopus and Lophius. Proc. Roy. Soc. London, Ser. B., 112: 242-249.