



Citation for published version:

Storey, J, Wilson, PR & Bagnall, D 2014, 'The Optimized-String Dynamic Photovoltaic Array', *IEEE Transactions on Power Electronics*, vol. 29, no. 4, pp. 1768-1776. <https://doi.org/10.1109/TPEL.2013.2265497>

DOI:

[10.1109/TPEL.2013.2265497](https://doi.org/10.1109/TPEL.2013.2265497)

Publication date:

2014

Document Version

Early version, also known as pre-print

[Link to publication](#)

"© 2014 IEEE. Personal use of this material is permitted. Permission from IEEE must be obtained for all other users, including reprinting/ republishing this material for advertising or promotional purposes, creating new collective works for resale or redistribution to servers or lists, or reuse of any copyrighted components of this work in other works.

University of Bath

Alternative formats

If you require this document in an alternative format, please contact:
openaccess@bath.ac.uk

General rights

Copyright and moral rights for the publications made accessible in the public portal are retained by the authors and/or other copyright owners and it is a condition of accessing publications that users recognise and abide by the legal requirements associated with these rights.

Take down policy

If you believe that this document breaches copyright please contact us providing details, and we will remove access to the work immediately and investigate your claim.

The Optimized String Dynamic Photovoltaic Array

Jonathan Storey, Peter R. Wilson, *Senior Member, IEEE*, and Darren Bagnall

Abstract—This paper presents a novel system for producing the optimum power output from photovoltaic arrays using dynamic cell reconfiguration. The proposed approach is the first in the literature that creates multi-cell sub-strings using individual cells that have been characterized and categorized ensuring maximum power extraction for a given irradiance profile. This optimized and decentralized PV architecture can produce significantly more power than a static equivalent (by an average of 22.6%) and also compared to an alternative irradiance equalized dynamic photovoltaic array (IEq-DPVA) (by an average of 13.7%). The paper identifies the hardware requirements to produce such a system and it describes an algorithm that performs the optimized string reconfiguration strategy. Finally, a simulator programmed in MATLAB is used to compare the performance of the optimized string DPVA (OS-DPVA) against an Irradiance equalized DPVA in a series of flexibility tests.

Index Terms—Dynamic Photovoltaic Array, Reconfigurable, Irradiance profiling

I. INTRODUCTION

The installation of photovoltaic arrays within urban scenes is becoming increasingly widespread and one of the biggest challenges facing mass integration within this setting is the issue of partial shading. Shading can be characterized as a drop in direct beam irradiance' relative to the surrounding environment. As the sun traverses the sky, the presence of buildings and other objects will cast shadows that move as the sun orientation changes. This shading on a PV array can result in complete or partial loss of irradiance across the arrays surface. Partial shading causes the biggest potential power loss because there is very little potential to lose in a completely shaded array (i.e. with zero irradiance there is nothing that can be done to improve the power output). The losses occur because the maximum power point (MPP) of the partially shaded cells become unsynchronized with that of the uniformly irradiated cells and it is not possible to draw a unique current while operating at multiple MPPs simultaneously.

A recent attempt to reduce the partial shading issue involves changing the topology of the PV plant. The most shade robust arrangement is the Module Integrated (MI) topology which involves connecting micro-converter or micro-inverters to each module in the array and a yield in excess of 240% have been reported [1]. This approach allows flexible plant design, lower hardware prices due to mass production and lower minimum array size, however the effectiveness of MI schemes can still be limited as incoherence within a module can still exist.

The inclusion of bypass diodes within an array structure has become the norm when considering static array design. Bypass diodes are discussed in section II of this paper but

other active methods have been developed to remove their intrinsic negative effects and improve power extraction. One such method is called Voltage Sharing and it replaces the bypass diodes with a bidirectional buck boost circuit and with the result that potentially up to a 40% Cold Bypass Switching (CBS) [2] is another method that gains power by lowering the losses caused by the conventional bypass diode. It uses MOSFETs and self-powered driving circuitry to pass current over failing cells. Estimates are that efficiency is improved by 2% and the device temperature is more than 60 cooler [3].

There are some alternative and innovative approaches to the partial shading issue include techniques known as a Virtual Parallel connected array (VPCA) and a Returned Energy Architecture (REA). These are two methods for moderating an injection of current in parallel with failing cells such that the coherence between the cells MPP is restored. They are distinctly different from other decentralized maximum power point tracking (DMMPT) schemes as their conversion techniques reinvest a portion of current back into the string instead of driving a load [4] [5].

Finally, the use of switches in the PV array structure to allow real time reconfiguration has become an actively researched technique to mitigate the effects of partial shading and increase usable power. Three main types of Dynamic Photovoltaic Array (DPVA) have been identified, and this work will evaluate the relative performance benefits of two of them. Early attempts at cell reconfiguration aimed to improve power extraction by arranging the array into a specific topology to produce a power characteristic to match a specific load. These DPVAs are referred to as Fixed Configuration and they are incapable of resolving complex shading conditions and are therefore not included in the analysis of the proposed work [6] [7] [8].

The most active area of research uses a method known as Irradiance Equalization to reduce the effects of partial shading. It involves organizing the PV cells within a Total Cross Tied (TCT) topology such that irradiance levels across the arrays surface is effectively averaged. This type of array is very effective at reducing the effects of partial shading and some implementations utilize adaptive banks instead of completely reconfigurable structures [9] [10] [11] [12] [13].

The third type of DPVA utilizes the Series Parallel (SP) topology in order to improve power extraction and remove current limitation caused by shaded cells. Several String Configured DPVA's with centralized distribution topologies have been proposed and the basic strategy is to create and load strings of un-shaded cells while still extracting power from the shaded cells [14] [15].

The main focus of this work is the development of Optimized String techniques, which builds on previous work by introducing dynamic reconfiguration while implementing the

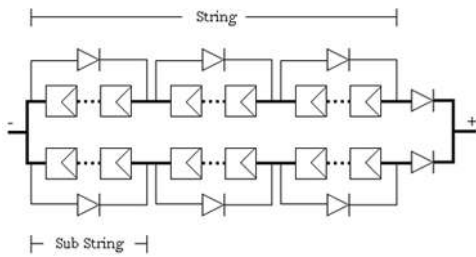

Fig. 1. Series Parallel (SP) configuration.

more robust multi-string decentralized topology. The remainder of this paper is structured as follows. Section II compares the typical static array topologies to the two relevant dynamic array topologies. Section III describes in detail the concept of optimized string reconfiguration while section IV discusses the general idea of decentralized maximum power point tracking. Section V deliberates the process of profiling the array and VI goes on to identify an algorithm that computes the optimal configuration. VII introduces the simulator and standard test cases while VIII presents the results. Finally, IX concludes the work with recommendations for future work.

II. COMPARISON OF CONVENTIONAL ARRAYS, IEQ-DPVAS AND SC-DPVAS

A. Static Arrays

1) *Series Parallel*: In conventional grid tied photovoltaic systems, the cells are connected into series parallel (SP) strings as shown in 1 where the string voltage tends to be in the range of 300V. In order to function safely under partial shading conditions, blocking diodes are positioned at the end of each string and bypass diodes are connected around collections of cells known as sub-strings. Without bypass diodes the current through each string is limited to approximately the short circuit current (ISC) of the weakest cell and so under partial shading conditions the whole string behaves as if it is shaded. If bypass diodes are included, a failing sub-string no longer restricts power extraction as it effectively become shunted from the current path and gets clamped at -0.6 Volts reversed bias. In terms of future research, there should be no comparisons between new innovations and static arrays without bypass diodes. Although bypass diodes tend not to be necessary in dynamic arrays, their inclusion can simplify the control requirements and create a more robust system.

2) *Total Cross Tied*: The IEq-DPVA relies on a topology known as a total cross tied (TCT) array 2. The TCT configuration builds on the SP configuration by connecting columns of sub-strings into parallel tiers and then connecting these tiers in series. It is significantly more robust than the SP configuration as the irradiance levels across each tier get averaged and strong cells can compensate for weak cells in the same tier. Interestingly, reports [17] [16] show that implementing the array in a TCT configuration doubles its in-service lifetime while not costing more to manufacture [18]. It must be noted that there is an asymmetry between the shading of rows and tiers on a TCT array and the progressive shading

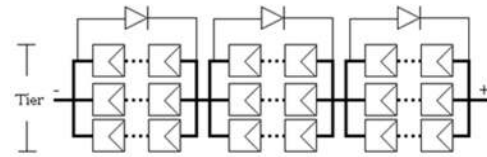

Fig. 2. Total Cross Tied (TCT) Configuration.

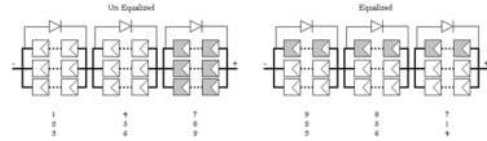

Fig. 3. Irradiance equalization of TCT array.

down a tier will affect power production more significantly than progressive shading across the rows.

B. Dynamic Arrays

1) *Irradiance Equalized DPVA*: If the TCT array is made dynamic, the Irradiance Equalization strategy 3 can be used to rearrange the cells such that the irradiance across each tier is equal. It involves electrically switching the sub-strings into positions where current limitation is at its smallest. This type of DPVA is extremely good at increasing power extraction when compared to a static array under shaded conditions. The proposed system will be compared to an IEq-DPVA operating under identical environments.

2) *String configured DPVA*: The most advanced string configured dynamic photovoltaic array (SC-DPVA) use a switching strategy that connects un-shaded cells into series parallel strings of a set size to form the SP topology with a single output. The shaded cells are then configured to operate in a single parallel tier that is connected to a DC-DC converter which is subsequently connected in parallel with the SP structure to drive the DC bus (see 4). Due to the centralized nature of this power conversion topology, the DC output from the panels is directly coupled to the AC inverter and large unreliable electrolytic capacitors (mF range) are needed to smooth the resulting ripple, otherwise the operating point of the PV array will oscillate and the maximum power point tracking is compromised. This issue has been highlighted in [19] and although there are several solutions utilizing active ripple compensation [20], the simplest method is to decouple the PV output from the AC input by implementing an intermediate DC-DC conversion stage.

III. OPTIMIZED STRING DPVA

A. Concept

The principle behind the optimized string DPVA is to create multiple power channels where each power channel only contains sub-strings of a similar power level. It means the dynamic array will have multiple optimized outputs feeding a DC-DC converter array which converges to a single DC link stage. For the system discussed in this paper, there will be four power channels but there could be any number of channels

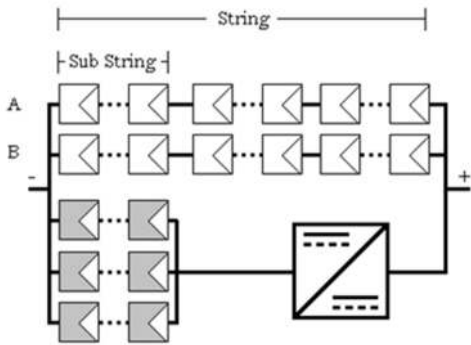

Fig. 4. Previous SC-DPVA strategy.

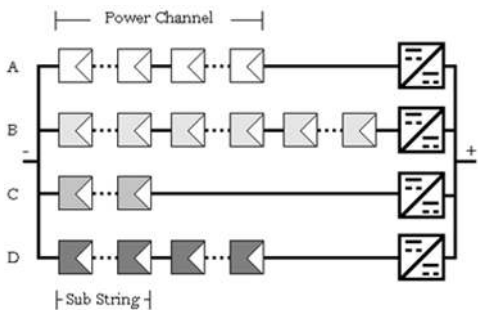

Fig. 5. Proposed Topology.

at the expense of more hardware. A DC-DC converter will load its respective channel such that it draws approximately IMAX of its weakest sub-string. The sorting algorithm uses this premise to calculate the most productive configuration for the given irradiance profile. There exist several publications on the process loading multiple PV strings with DC-DC converters such that they operate at their maximum power point [21]. There are advantages and disadvantages associated with the each of the various converter types and so it is up to the designer to select the most appropriate, based on the requirements of the array [22].

Due to the unpredictable nature of the shading profiles, it is likely that the number of sub-strings within each channel will be different. This means that each converter must accept a wide input voltage range and have the capacity to resolve the voltage imbalance in order to feed the DC link stage efficiently. An example of a 'perturb and observe buck-boost maximum power point tracking converter which accepts voltages from 0-850V and feeds a DC link of 320V is described in [23]. These converters have a reported efficiency of around 98%.

B. Switch Matrix

All dynamic arrays require a switch matrix to route current between the individual sub-strings and the repeated set of switches that surround each sub-string is known as a switch set. The topology and interconnections of a switch set will govern how the array is to behave when under intelligent control. For the OS-DPVA, each sub-string must be able to accept or reject current flow from either of the power channels and 6 shows the switch set that realizes this. An example of a switch set that creates a dynamic TCT array can be found in [24].

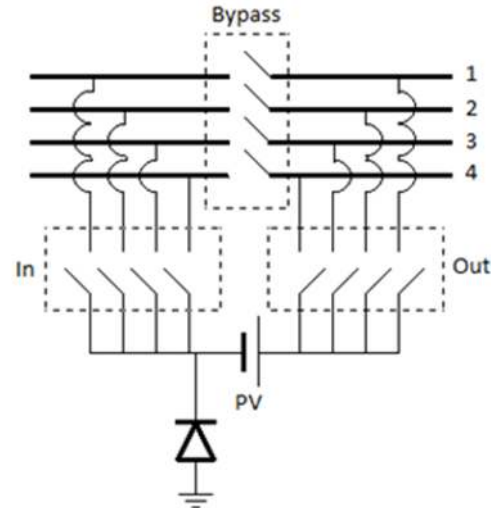

Fig. 6. 'Switch Set' for proposed topology.

With 12 switches controlling the current flow from the PV, there are 212 unique ways (4096) to configure them. Obviously only a small fraction of these are electrically useful and for complete control over the array configuration there are only 9 states that the switches must occupy. The four most common states divert current from the channel through the PV and these are used by all sub-strings except the first one in the channel. There are four grounding states that utilize a diode to return current from the load and only the first sub-string in each channel utilizes this state. Each switch must be bidirectional to avoid unwanted reverse currents flowing through the network.

The proposed OS-DPVA switch matrix requires 194 switches while the IEq-DPVA of similar capacity only requires 112 as described by equations 1 and 2 respectively. This results in 82 more switches for the OS-DPVA system described in this paper. It is possible to reduce the by implementing a 3 channel device which would require only 32 extra switches.

$$Switches_{OS-DPVA} = 3 * SubStrings * Channels \quad (1)$$

$$Switches_{IEq-DPVA} = (2 * Teirs) - 1 * SubStrings \quad (2)$$

IV. DECENTRALIZED MULTIPLE STRING SYSTEMS

A. Introduction

As stated, the literature suggests [19] that a two stage power converter is much better at tracking the MPP of the array while offering the use of smaller and more reliable capacitors. Thus far, there are no decentralized multi-string systems that include the process of accurately profiling the power producing capabilities of the sub-strings and then intelligently reconfiguring them into larger strings (known as power channels). The strategy discussed in this paper will create four power channels where each is loaded by its own DC-DC converter operating as a MPPT. The array will have been profiled and dynamically reconfigured such that the minimal amount of current limitation is exhibited between the sub-strings that constitute these channels.

B. Decentralized Voltage Conversion

The most prevalent PV system architecture is the single string configuration with a central tied inverter. This topology was considered economic and simplistic as it requires one high power converter operating at a high DC voltage to facilitate grid tied power inversion. However, recent studies have shown that centralized conversion strategies are generally less effective at converting incident sunlight into electricity than the decentralized conversion topologies within urban environments [1]. This is due to their being less current limitation within the smaller multiple stringed systems than with a single stringed system operating under identical conditions. Other benefits of the modular decentralized systems include conveniently upgradable arrays, the ability to utilize different cell types and a resilience to complete failure in the event of malfunction. One can also create PV plants where portions of the array face different orientations, forming a strong argument for use in building integrated systems. Also, although the topology utilizes multiple DC-DC converters at the input stage, it still only requires a single high power AC inverter for the output stage. This is the first time that decentralized strings have to be reorganized through dynamic rearrangement.

C. Distributed Switches and Distributed Converters

Due to the presence of multiple channels in the OS-DPVA system, it is fundamentally a distributed converter topology and normally the concept of converter granularity must be addressed. However, as the system is a synergy between dynamic reconfiguration and a distributed string topology, the OS-DPVA requires the designer to contemplate the switch granularity instead. There are only four sensible divisions within an array and as such, the switch network can be dispersed at the cell level, the sub-string level, module level or at the end of a string. This arises because other dissection patterns will result in an unequal division of cells and wiring accesses will become an issue. 7 shows these levels of granularity. From [??], high level simulations are used to quantify the benefit of tuning converter granularity to suit the arrays destination. As a result they conclude that the sub-string granularity was most appropriate for use in high shade urban areas as it performs similar to the cell level distribution but benefits from being considerably cheaper and far more convenient to implement. Using this information, it is possible to deduce that this would also be the most suitable level for the switch dispersion throughout the array.

V. PROFILING THE ARRAY

A. Insolation Profile

In order to effectively control the dynamic array, information about the insolation conditions (and derivatives thereof) across each sub-string is required. It is possible to estimate the amount of irradiance reaching the surface by taking IV measurements and using 3 which relates irradiance to the basic PV model through a proportionality constant α .

$$G = \alpha * [I + I_{SAT} * (e^{\frac{V}{nkT}} - 1)] \quad (3)$$

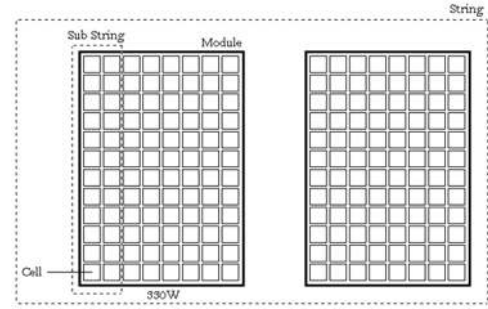

Fig. 7. Possible granularity from an Array.

Although irradiance is a useful figure for basic analysis and environment setting, it is far more accurate to perform optimizations based on the current producing capabilities of the PV devices. Firstly, none of the PV cells are perfectly matched (with typical tolerances of 5%) and all of these individual manufacturing discrepancies get compounded when dealing with multi cell sub-strings. Consequently, sub-strings receiving the same insolation might produce different IV characteristics. As mentioned before, a feature which is a strong advantage to decentralized systems is the ability to include modules of different specification or chemistry within the design. By profiling via IV measurement, any ambiguities caused by the integration of dissimilar modules are reduced. Finally, as solar cells are primarily current sources, using this variable to categorize them gives a precise indication to the amount of electrical power being generated and this information can then be used to more effectively drive the DC-DC converters. The insolation profile is a virtual map containing information about a sub-strings physical location and the IV characteristic it exhibits when operating at the maximum power point. It is required in order to obtain the optimal configuration and then derive how to correctly control the switch matrix.

B. Sense Configurations

A feature that is inherent to dynamic arrays is the ability to arrange the sub-strings into specific configurations. Most of these configurations are used to extract power from the array, but it is possible to produce configurations that allow accurate characterization of the PV devices. One sense configuration for the proposed dynamic array involves putting a single sub-string within the channel and performing a current sweep while measuring the voltage. When the string reaches the temperature compensated maximum power voltage (VMAX), the exact locus of the maximum power point has been identified and the information is stored. The current sweep procedure can be performed by the DC-DC converters and by starting from a short circuit condition and reducing current the drawn, the time taken to determine the IV characteristic can be minimized.

VI. SORTING ALGORITHM

A. Introduction

Once the maximum power point of all sub-strings has been identified, an algorithm can sort them into the optimized

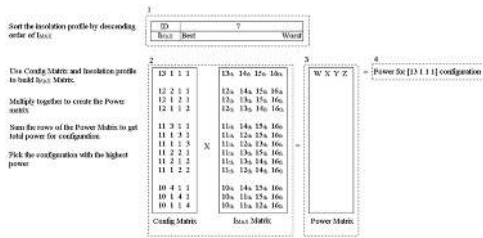

Fig. 8. Matrix Multiplication Algorithm.

power channels. Each channel will contain only the sub-strings that collectively minimize the current limitation through the branch. However, there will always be some current limitation caused by the coupling of the best and worst sub-strings but as the algorithm finds the most productive configuration, the minimum amount of power is lost through this mechanism.

The algorithm requires the use of element-wise matrix multiplication and will identify every single configuration and simply pick the best. This is very useful in the analysis of the OS-DPVA as it shows every single state that the system can exist in and that can be used to evaluate effectiveness of other sorting procedures. During the sorting process, it is assumed that the maximum current draw through any of the channels is limited to the IMAX of the weakest sub-string.

B. Matrix Multiplication

This method uses a predefined look up table known as a configuration matrix which describes all of the possible configurations given the number of sub-strings and the number of channels within the system. It uses this and the insolation profile to construct a second matrix known as the 'IMAX matrix' which contains the maximum currents allowed through each channel given the said configuration. These matrices are element wise multiplied together to produce as a third matrix known as the power factor matrix this indicates how much normalized power is being produced by each channel for that configuration. By summing all of the channels power together, the total normalized output power for the array is found. As this procedure employs look up tables and operates using only integer multiplication, it is very rapid and results in a comprehensive portrayal of the arrays possible configurations.

VII. THE SIMULATOR

A. Overview

A simulator has been programmed in MATLAB which can simulate the output characteristics of any array configuration with regards to the IEq-DPVA's TCT topology and the OS-DPVA's multiple string topology. This allows direct comparison of the expected output power under particular insolation conditions. A nominal test array of four identical 330 Watt panels has been used for all examples where each module contains 96 five inch cells. This divides into a DPVA with 16 sub-strings where each sub-string contains 24 cells. A simple cell model has been implemented based on the standard circuit level described by 4, and more conveniently equation 5 and 6 which links irradiance to key IV loci based on known physical

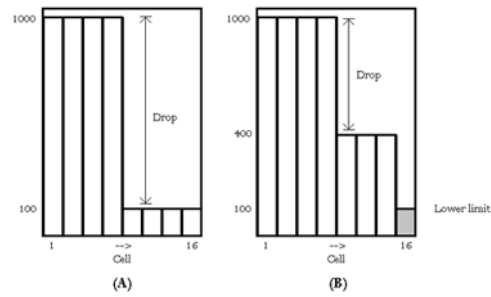

Fig. 9. Progressive Drop Tests.

and electrical properties. The parameters of the cell model have been tuned so that they closely match the characteristics of the SunPower e20 modules.

$$i_{ph} = i_{sat} * (e^{\frac{qV}{nKT}} - 1) - \frac{V}{R_{Shunt}} \quad (4)$$

$$I_{MAX} = \frac{\mu(Irradiance_{cm^2} Area_{cm^2})}{V_{MAX}} \quad (5)$$

$$i_{ISC} = I_{MAX} + \frac{V_{MAX}}{R_{Series}} \quad (6)$$

B. Test cases

In order to test the proposed system against the existing IEq-DPVA, several shading incidents were defined. The overall irradiance can either be uniform or distributed in nature and discrete shading profiles imposed on particular substrings. Three test types have been identified and used to evaluate performance. For simplicity the losses associated with the converters and switch sets have been omitted. Progressive drop tests.

The progressive drop tests will sequentially shade the sub-strings of the uniformly irradiated array and monitor power output. This emulates block shading of the array and results in two irradiance levels incident upon its surface (9A). A second round of progressive drop tests introduces a third irradiance level that is referred to as the lower limit (9B). For all of the tests conducted, the direction of the progressive shading has been chosen to be down tier as it produces the biggest difference between the static array and the IEq-DPVA. Had the progressive shading been applied in the across row direction, these two arrays will all ways produce the same power.

C. Step Test

The step tests will progressively vary the value of irradiance on each sub-string where the step size can be at consistently regular intervals (i.e. steps of ten) or at interesting irrational intervals such as phi or pi. It seems unlikely that these shading profiles will exist in everyday environments but they are useful in evaluating the flexibility and limitations exhibited by each of the dynamic arrays.

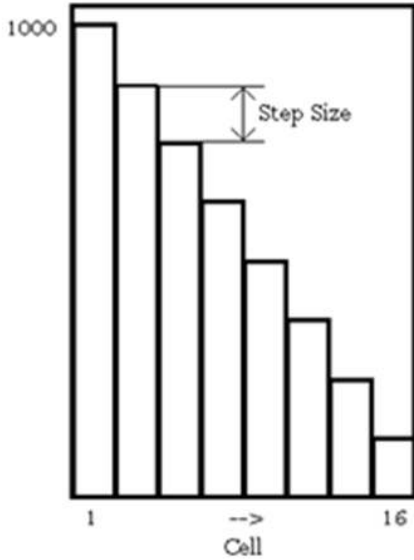

Fig. 10. Step Tests.

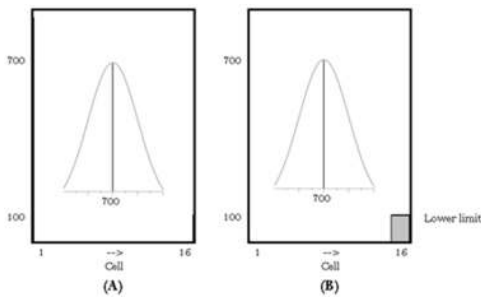

Fig. 11. Distributed Irradiance Tests.

D. Distributed Tests

This set of tests will produce an irradiance environment where each cells insolation is randomly selected based on a Gaussian distribution ranging between 100W/m2 and 1100W/m2. The mean irradiance is set to 700W/m2 and the variance is incremented by intervals of 50 from zero to 500. This emulates a variety of shading scenarios from a light cloud hazing to intense dappled obstruction. The second set of distributed tests introduces a lower limit from a single sub-string. As the simulator only selects 16 random irradiances per simulation, this sample range can vary considerably for each instance of distribution under test. So to extract meaningful results, each distribution is simulated 500 times and the average power producing abilities of the arrays is taken.

VIII. RESULTS

A. Progressive Drop Tests

B. Progressive Block Shaded Cells with single lower limit

C. Discussion

From the progressive drop tests in 1, the OS-DPVA (Black) can be seen to completely avoid current limitation and produce the maximum power under all conditions. This is expected

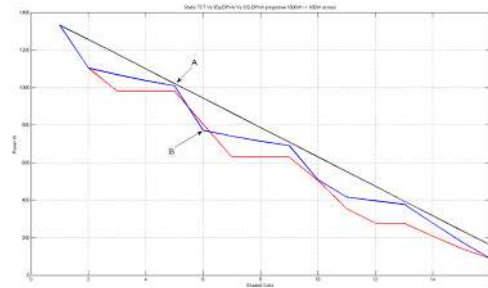

Fig. 12. Progressive Shading.

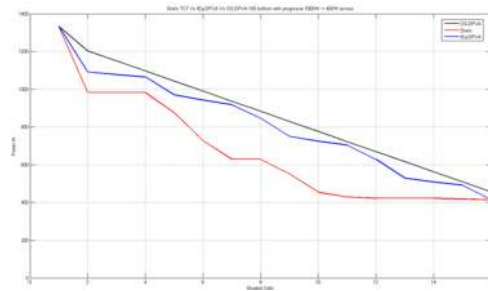

Fig. 13. Static, IEq and OS DPVA for test 2.

as the power channels can accommodate up to four unique MPPs before current limitation occurs whereas the IEq-DPVA (blue) requires a particular distribution before 100% extraction is possible (Point A on 12). An important observation as shown by point B is the shading case where a static TCT array actually produces more power than a dynamically reconfigured IEq-DPVA. It occurs because the static array uses 9 fully irradiated sub-strings and encounters a single bypass diode whereas the dynamic array uses 8 fully irradiated sub-strings coupled with 4 shaded sub-strings. Although these situations are likely to be very rare, it highlights that reconfiguration can be detrimental to the overall energy yield. The OS-DPVA produces an average 13% more power than the IEq-DPVA with a minimum of 1% to a maximum of 44% increase. The results of a progressive drop with lower level are shown in 13. Once again the OS-DPVA can operate at maximum power because it can synchronize the MPP of all the sub-string under its control. Notice how the IEq-DPVA maintains its characteristic shape with the exception that it can no longer ever achieve 100% power extraction. This is because there exists no configuration where irradiance is fully equalized. The effect of the lower limit sub-string on the static array is profound as it causes a dramatic loss of power as shading increase. Here the OS-DPVA produces an average of 6% improvement with a range between 2% 14%

D. Stepped tests

E. Discussions

The first stepped test shows that the OS-DPVA and the IEq-DPVA perform almost equivalently under regular non uniform insolation conditions but the IEq-DPVAs ability to improve power extraction does eventually exceed that of the OS-DPVA by 11% as step size increases. Results from the

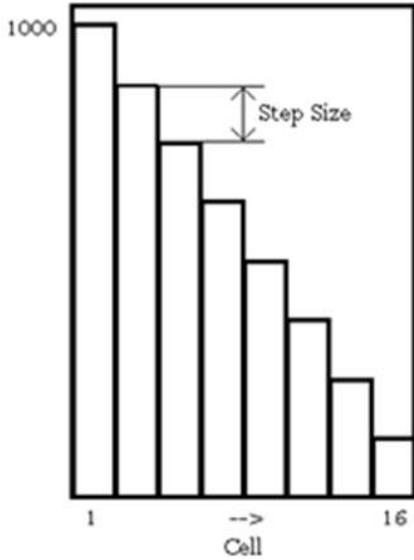

Fig. 14. Stepped Tests.

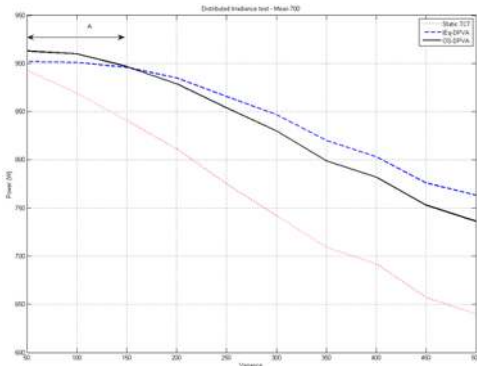

Fig. 15. Non Uniform Shading.

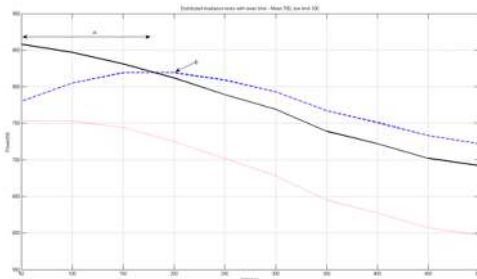

Fig. 16. Non Uniform Shading with lower limit.

irregularly distributed step test show much of the same results but it is anticipated that a more profound difference would be witnessed as the number of cell within the array increases.

F. Distributed Irradiance Test Cases

- 1) non uniform shading:
- 2) non uniform shading single lower limit:
- 3) Discussions: The region referred to by point A on figure 15 and 16 can be thought of as a light hazing of sunlight

and in both tests it shows the OS-DPVA is able to better extract energy from the array under these conditions. Point B in the distributed with lower level test draw attention to the peak that raises and falls in the IEq-DPVAs power as variance progresses. In the first test, the OS-DPVA produces a maximum of 1% increase which falls to a 3.6% loss, while in the second test it produces a maximum of a 10% increase to a minimum of 4.3% loss .

IX. CONCLUSIONS

The work in this paper proposes a new and advanced method for the dynamic reconfiguration of a photovoltaic array based on the string configured topology. This architecture exhibits characteristics which could prove beneficial within an urban setting. When compared to a more highly developed DPVA (IEq-DPVA), the OS-DPVA approach performs exceptionally well under uniform progressive shading cases where the OS-DPVA could maintain 100% extraction and the IEq-DPVA can only achieve this level in select environments. These shading profiles are expected to be prevalent in urban environments due to the block shading caused by obstacles. Under randomized non-uniform conditions with a low variance (i.e. hazy sunlight), the OS-DPVA can also produce more power than the IEq-DPVA. As variance increases, the OS-DPVA retains the ability to evade situations where heavy shading could restrict current through the stronger sub-strings and performs approximately 10% worse than the IEq-DPVA. The optimized string dynamic photovoltaic array is inherently a distributed plant with a dual stage power conversion topology. Conveniently, recent works have suggested that distributed systems can improve reliability, exploit unconventional layout frameworks and increase power extraction. While dual stage power converters seem preferable due to a simplistic maximum power point tracking strategy, a reduced capacitor requirement and general familiarity with components. By introducing the features of a reconfigurable array, the system becomes robust and able to significantly reduce the effects of partial shading. There is a significant increase in hardware and control requirements when compared to a static array but there is not a great deal of difference when considering other dynamic arrays. Basic microelectronic components are required by both and the process of interfacing to the switch network is identical. The OS-DPVA requires more switches per sub-string to implement which increases its cost and reduces the mean time before failure. However, any sophisticated large scale DPVA will always require a large number of switches thereby reducing the significance of this issue when viewed comparatively. It must be said that the testing used in this paper aimed to highlight the worst case scenarios and highlight different aspects of the arrays MPP synchronization capacities. Prototypes of each are under construction with the aim of extracting and evaluating real data.

REFERENCES

[1] Sanz, A.; Vidaurrazaga, I.; Pereda, A.; Alonso, R.; Roman, E.; Martinez, V.; , "Centralized vs distributed (power optimizer) PV system architecture field test results under mismatched operating conditions," Photovoltaic Specialists Conference (PVSC), 2011 37th IEEE , vol., no., pp.002435-002440, 19-24 June 2011

- [2] R. Giral, C.A. Ramos-Paja, D. Gonzalez, J. Calvente, A. Cid-Pastor, L. Martinez-Salamero, Minimizing the effects of shadowing in a PV module by means of active voltage sharing, *Industrial Technology (ICIT), 2010 IEEE International Conference on*, vol., no., pp.943-948, 14-17 March 2010
- [3] Acciari, G.; Graci, D.; La Scala, A.; , Higher PV Module Efficiency by a Novel CBS Bypass, *IEEE Transactions on Power Electronics*, vol.26, no.5, pp.1333-1336, May 2011
- [4] Poshtkouhi, S.; Biswas, A.; Trescases, O.; , "DC-DC converter for high granularity, sub-string MPPT in photovoltaic applications using a virtual-parallel connection," *Applied Power Electronics Conference and Exposition (APEC), 2012 Twenty-Seventh Annual IEEE*, vol., no., pp.86-92, 5-9 Feb. 2012
- [5] Nimni, Y.; Shmilovitz, D.; , "A returned energy architecture for improved photovoltaic systems efficiency," *Circuits and Systems (ISCAS), Proceedings of 2010 IEEE International Symposium on*, vol., no., pp.2191-2194, May 30 2010-June 2 2010
- [6] Z.M Salamehand and F. Dagher, The effect of electrical array reconfiguration on the performance of a PV-powered volumetric water pump, *IEEE Transactions on Energy Conversion*, vol.5, no.4, pp.653-658, Dec 1990
- [7] Y. Auttawaitkul, B. Pungsiri, K. Chammongthai, and M. Okuda, A method of appropriate electrical array reconfiguration management for photovoltaic powered car, *IEEE Asia-Pacific Conference on Circuits and Systems, 1998*, pp.201-204, 24-27 Nov 1998
- [8] Salameh, Z.M.; Liang, C.; , "Optimum switching points for array reconfiguration controller," *Photovoltaic Specialists Conference, 1990., Conference Record of the Twenty First IEEE*, vol., no., pp.971-976 vol.2, 21-25 May 1990
- [9] G. Velasco, J.J. Negroni, F. Guinjoan, R. Pique, Irradiance equalization method for output power optimization in plant oriented grid-connected PV generators, *European Conference on Power Electronics and Applications, 2005*, p10
- [10] D. Nguyen and B. Lehman, An Adaptive Solar Photovoltaic Array Using Model-Based Reconfiguration Algorithm., *IEEE Transactions on Industrial Electronics*, vol.55, no.7, pp.2644-2654, July 2008
- [11] D. Nguyen and B. Lehman, A reconfigurable solar photovoltaic array under shadow conditions, *Applied Power Electronics Conference and Exposition, 2008. APEC 2008. Twenty-Third Annual IEEE*, vol., no., pp.980-986, 24-28
- [12] G. Velasco-Quesada, F. Guinjoan-Gispert, R. Pique-Lopez, M. Roman-Lumbreras, A. Conesa-Roca, Electrical PV Array Reconfiguration Strategy for Energy Extraction Improvement in Grid-Connected PV Systems, *IEEE Transactions on Industrial Electronics*, vol.56, no.11, pp.4319-4331, Nov. 2009
- [13] Z. Cheng, Z. Pang, Y. Liu and P. Xue; , An adaptive solar photovoltaic array reconfiguration method based on fuzzy control, *Intelligent Control and Automation (WCICA), 2010 8th World Congress on*, vol., no., pp.176-181, 7-9 July 2010
- [14] L.A.R. Tria, M.T. Escoto, C.M.F. Odulio, Photovoltaic array reconfiguration for maximum power transfer, *TENCON 2009 - 2009 IEEE Region 10 Conference*, vol., no., pp.1-6, 23-26 Jan. 2009
- [15] M.A. Chaaban, M. Alahmad, J. Neal, J. Shi, C. Berryman, Y. Cho, S. Lau, H.Li, A.Schwer, Z. Shen, J. Stansbury, T. Zhang, Adaptive photovoltaic system, *IECON 2010 - 36th Annual Conference on IEEE Industrial Electronics*, vol., no., pp.3192-3197, 7-10 Nov. 2010
- [16] Kaushika, N.D.; Gautam, N.K.; , "Energy yield simulations of interconnected solar PV arrays," *Energy Conversion, IEEE Transactions on*, vol.18, no.1, pp. 127- 134, Mar 2003
- [17] L. Gao, R.A. Dougal, S. Liu and A.P. Iotova, Parallel-Connected Solar PV System to Address Partial and Rapidly Fluctuating Shadow Conditions, *Industrial Electronics, IEEE Transactions on*, vol.56, no.5, pp.1548-1556, May 2009
- [18] El-Dein, M. Z. Shams; Kazerani, M.; Salama, M. M. A.; , "Optimal total cross tied interconnection for photovoltaic arrays to reduce partial shading losses," *Power and Energy Society General Meeting, 2012 IEEE*, vol., no., pp.1-6, 22-26 July 2012
- [19] Schonberger, J.; , "A single phase multi-string PV inverter with minimal bus capacitance," *Power Electronics and Applications, 2009. EPE '09. 13th European Conference on*, vol., no., pp.1-10, 8-10 Sept. 2009
- [20] Testa, A.; De Caro, S.; , "Active voltage ripple compensation in PV Systems for domestic uses," *Industrial Electronics (ISIE), 2010 IEEE International Symposium on*, vol., no., pp.2193-2198, 4-7 July 2010
- [21] Khajehoddin, S.A.; Bakhshai, A.; Jain, P.; , "A Novel topology and control strategy for maximum power point trackers and multi-string grid-connected PV inverters," *Applied Power Electronics Conference and Exposition, 2008. APEC 2008. Twenty-Third Annual IEEE*, vol., no., pp.173-178, 24-28 Feb. 2008
- [22] Edrington, C.S.; Balathandayuthapani, S.; Jianwu Cao; , "Analysis and control of a multi-string photovoltaic (PV) system interfaced with a utility grid," *Power and Energy Society General Meeting, 2010 IEEE*, pp.1-6, 25-29 July 2010
- [23] Wu, T.; Yang, J.; Lin, L.; Chen, Y.; , "Design and implementation of multiple maximum power point trackers for multi-string PV panels in DC distribution systems," *Applied Power Electronics Conference and Exposition (APEC), 2012 Twenty-Seventh Annual IEEE*, pp.563-567, 5-9 Feb. 2012
- [24] Storey, J.; Wilson, P.; Bagnall, D.; , "Improved Optimization strategy for Irradiance Equalization in Dynamic Photovoltaic Arrays," *Power Electronics, IEEE Transactions on*, vol. PP, no.99, pp.1, 0
- [25] Poshtkouhi, S.; Palaniappan, V.; Fard, M.; Trescases, O.; , "A General Approach for Quantifying the Benefit of Distributed Power Electronics for Fine Grained MPPT in Photovoltaic Applications Using 3-D Modeling," *IEEE Transactions on Power Electronics*, vol.27, no.11, pp.4656-4666, Nov. 2012