

The Parameters Identification and Validation for IGBT Based on Optimization Algorithm

GAO Yanxia¹, MIAO Yingying¹, GUO Shuibao¹, Wang Daohong²

1 The Dept. of Automation, Shanghai University

2 Department of Electrical Engineering, The Hong Kong Polytechnic University

Eemail:gaoanna@yahoo.com.cn

Abstract IGBT (Insulated Gate Bipolar Transistor) is becoming more and more popular in many power applications, since it offers a good compromise between on-state loss, switching loss and easy of use. To develop circuits and systems using these devices, model and model parameters are needed for use in circuit simulations. This paper presents a procedure for identifying the most IGBT models parameters. As an example, the results of identified parameters of BUP302 are given. Based on the identification, the paper presents the method for parameters validation. At last, the conclusion was given.

1. Introduction

For the design and analysis of power electronic circuits, simulation becomes more and more important in order to predict the behavior of the proposed circuits. In recent years, the Prototype-less design of power electronic system has appeared, hence a more accurate simulation result is required, as it must be more approach to practical circuit characteristics. The accuracy of simulation result mainly depends on the power electronic devices model and its parameters. Therefore the modeling of device and its parameter identification is always one of the research directions in power electronic.

Having the virtue of high current density and low drive power, the insulated gate bipolar transistors (IGBT) are widely used in the area of power electronic converter and electronic drives. In the mean time, the modeling of IGBT and its parameter identification become a research focus. Generally, the models are categorized into two different classes [1]. The first is "behavioral" or "empirical." [2], this kind of model is based on equivalent circuit, simple but not enough accuracy. The second is Mathematical-physical model. It refers to mathematics

equation based on IGBT physical structure [3-5]. This kind of model can precisely describe the physical characteristics of IGBT. Reviewing the IGBT model parameter extraction method described in the literatures, there are several different methods of parameter extraction. In [6] and [7], the parameter extraction proposed is based on behavioral model. Reference [8] proposed a parameter extraction method, but lacked detail. The parameter extraction provided for the mathematical- physical model [9] is developed with seven very precise. It is so complex that it is not practical for electrical engineers. This paper proposes a method of parameter identification and its validation for IGBT based on experiment, simulation and an optimization algorithm. The procedure is valid for different families of IGBTs such as PT and nonpunch-through(NPT). We take NPT IGBT BUP302 as an example for the parameter identification and validation. The simulation software used is PACTE, developed by CEGELY. After the parameter extraction, the paper proposes a validation method. Once the parameter extraction and validation are complete, the parameter may be used for the models implemented on any circuit simulations software to get more accurate simulation results. The extraction method can be easily used for electrical engineers

2. The Mathematical-physical Model and Its Parameters for IGBT

Being a conductivity-modulated power device, the behavior of an IGBT depends heavily on the carrier distribution in its wide drift region. For IGBTs, it is 1-D across 90% of the drift region[], and so may be reasonably assumed as such for the whole region provided some modification are made. Under these conditions, assuming high-level injection, the ambipolar carrier diffusion equation (1) describes the carrier dynamics.

This paper and its related research are supported grants from the Power Electronics Science Education Development Program of Delta Environmental & Development and the Fund of Shanghai Education Committee

$$D \frac{\partial^2 p(x,t)}{\partial x^2} = \frac{p(x,t)}{\tau_{HL}} + \frac{\partial p(x,t)}{\partial t} \quad (1)$$

Where D is the ambipolar diffusion coefficient, τ is the high level carrier lifetime within the drift region, and $p(x,t)$ is the excess carrier concentration.

According to semiconductor physical theory, Hefner built the static and dynamic model of IGBT. The structure and equivalent circuit of NPT IGBT are shown in Fig.1 and Fig.2. The parameters of this model are listed in Tab.1. The mathematical description of the model can refer the reference[4] and [5]

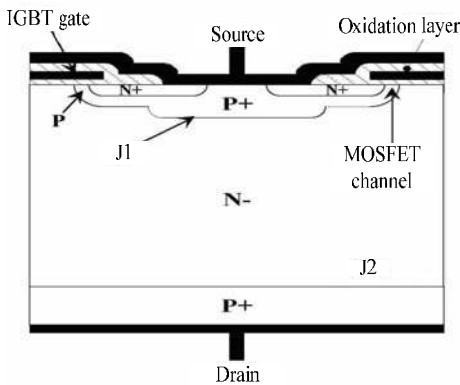

Fig. 1 The structure of NPT IGBT

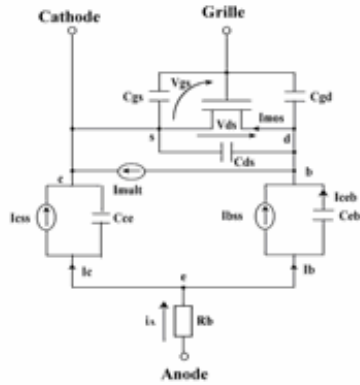

Fig. 2 The equivalent circuit of NPT IGBT

3. IGBT Model Parameter Identification and Optimization Algorithm

The proposed parameter extraction procedure consists of two separate steps.

1) Initial Parameter Extraction—this is based on device datasheets and at most one clamped inductive switching experiment[10];

2) Optimization Procedure—Refinement of parameters through a formal optimization procedure.

The process of parameter extraction is shown in Fig.3.

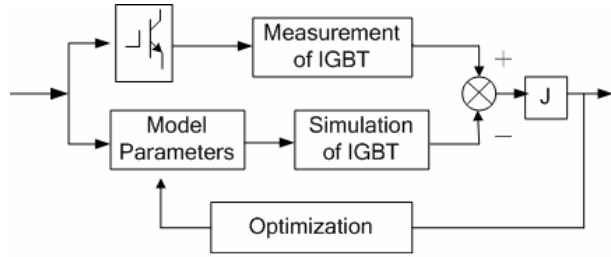

Fig.3 Diagram showing the procedure extraction

The process of identification is that the simulated waveforms approach to the measured waveforms via optimizing. The IGBT model parameters are divided into the static parameter and the dynamic parameter, so the process of identification can also be divided into the static model parameter identification and the dynamic model parameter identification. The object function of static parameters identification is made up of the difference between static measurement characteristic and simulation, shows as (1).

$$J = \sqrt{\sum_{m=1}^M \int_{V_{ce}=0}^{V_{ce}=V_{ce\max}} \delta_{V_{ce}}^2 dV_{ce}} \quad (2)$$

Where

$$\delta_{V_{ce}} = \left| \frac{i_c^s(v_{ce}^s) - i_c^e(v_{ce}^e)}{i_c^e(v_{ce}^e)} \right|$$

The object function of dynamic parameters identification shows as (2)

$$J = \sqrt{\sum_{i=1}^n k_i \Delta_i^2} \quad (3)$$

Where

$$\Delta_i = \left| \frac{x_i^m - x_i^s}{x_i^m} \right|$$

x_i^m And x_i^s denote some measured value or simulated value of curves characteristics separately.

According to the optimization algorithm, the model parameters in simulation model is the identified parameter when object function gets enough small. As an example, Table 1 shows the BUP302 parameter value after optimization, and Fig. 4 to Fig. 11 show the compares of experimental and simulated waveforms of V_{GS} , I_g ,

V_{DS} and I_D . Fig. 12 shows the object function during the process of optimization.

Tab.1 the identified results of BUP302's parameters

Physical Meaning	Symbol	Unit	Identified Value
Device active area	A	cm^2	0.149999
Gate-drain overlap area	A_{gd}	mm^2	11.94
Drift region (base) width	W_B	μm	90.0
IGBT MOSFET threshold voltage	V_{TH}	V	6.0000489
Gate-drain overlap depletion threshold	V_{Td}	V	0.247
Linear region MOSFET transconductance parameter	K_{plin0}	A/V^2	1.8
Saturated region MOSFET transconductance parameter	K_{psat0}	A/V^2	0.799121
Gate-source capacitance	C_{gs}	nF	0.5332
Gate-drain overlap oxide capacitance	C_{oxd}	nF	0.3203
Emitter electron saturation current	I_{sne}	A	$5.5283447 e^{-12}$
Minority carrier lifetime in buffer layer	τ_{HL}	μs	12.4375
Drift region (base) doping concentration	N_B	cm^{-3}	$15.0e^{13}$
Proofed coefficient allowed by calculate the range of MOSFET cross section	$tetal$	V	110.990234

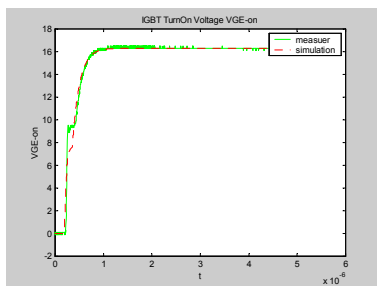
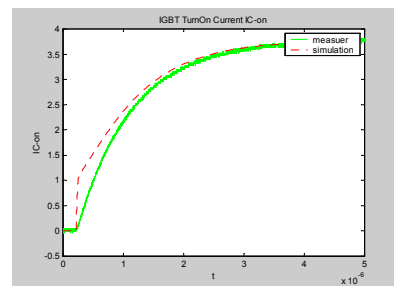
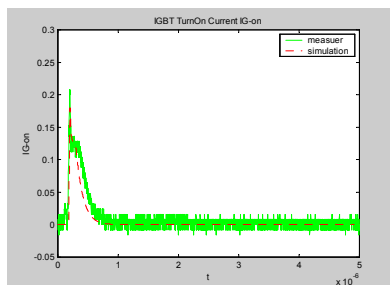
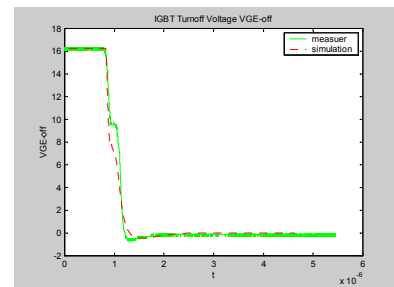
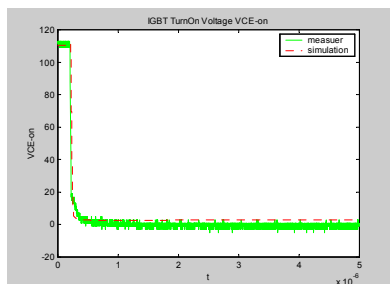
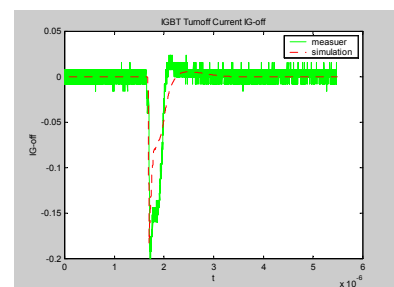
 Fig. 4 The IGBT turn-on V_{GS} waveform

 Fig. 7 The IGBT turn-on drain current I_D waveform

 Fig. 5 The IGBT turn-on I_g waveform

 Fig. 8 The IGBT turn-off V_{GS} waveform

 Fig. 6 The IGBT turn-on V_{DS} waveform

 Fig. 9 The IGBT turn-off I_g waveform

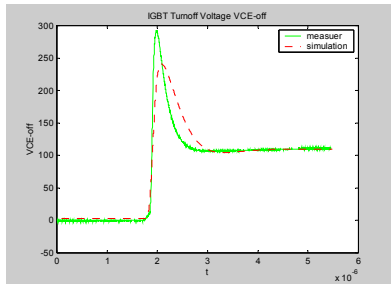

Fig. 10 The IGBT turn-off V_{DS} waveform

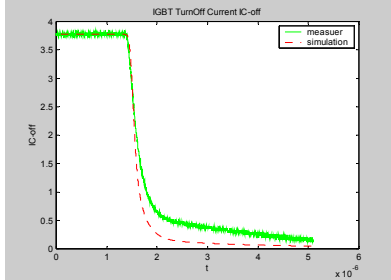

Fig. 11 The IGBT turn-off drain current I_D waveform

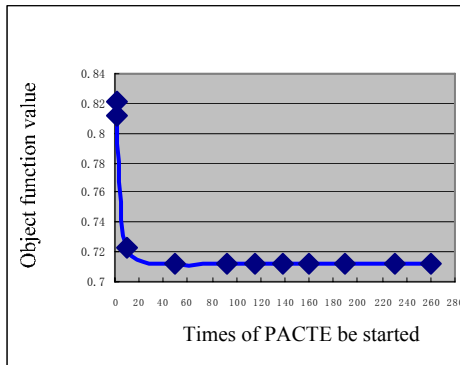

Fig. 12 The object function during the procedure of optimization

4. Validation of Model Parameter Identified

The identified parameters are obtained under certain voltage and certain current and can guide the reasonable simulation results. The question is whether they are valid over a wide range of voltage and current.

Changing the voltage source V_R and current source I_F

in wide range, we can get the dynamic curves and its characteristic values under different voltage and current. Simulating under the same condition, we can get simulated transient waveform. Fig.13 shows experimental and simulated results of drain current I_{c_on} , under different current and voltage. The difference between experiment and simulation make up validation chart, as Fig.13(c). Fig.14 shows the relative error of V_{DS} when the IGBT turns on and the Fig.15 is the max. V_{DS} when the IGBT turns off. Fig.16 is the validated result of miller voltage of V_{GE} when the IGBT turns off.

The validated results could be applied to:

- (1) the improvement of device models;
- (2) chosen reference for device user;
- (3) for the device user evaluates the simulation precision.

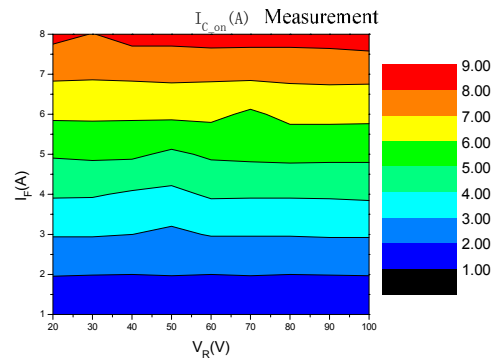

a) Experimental result of on-state drain current

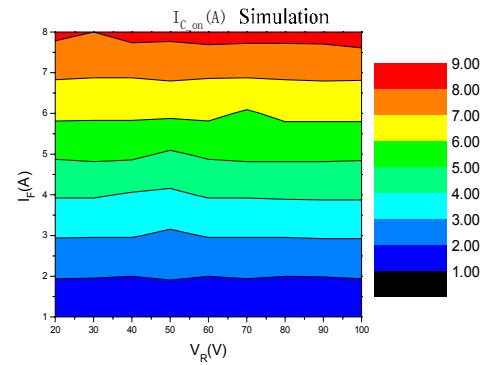

b) Simulated result of on-state drain current

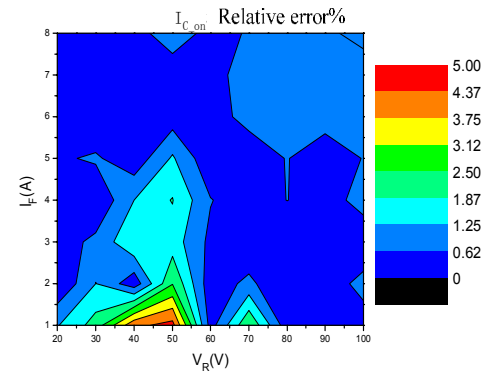

c) The validated result of on-state drain current

Fig. 13 The on-state drain current

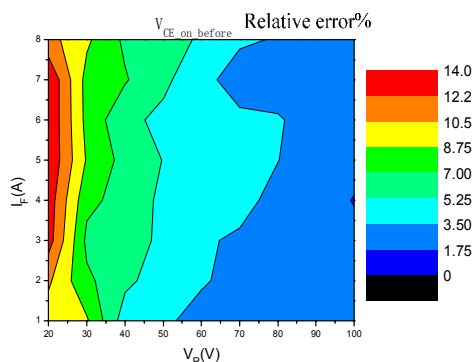
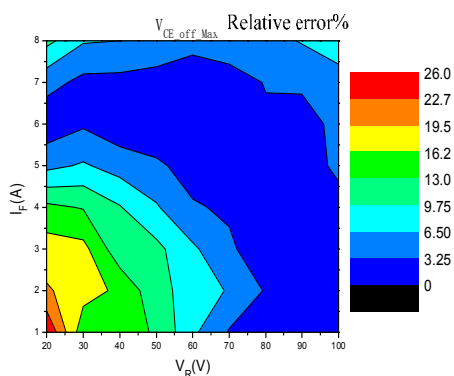
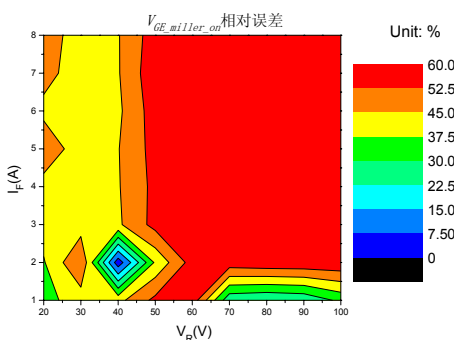

Fig.14 The validated result of on-state VDS

Fig.15 The validated result of turn-off $V_{DS_off_max}$ Fig. 16 The validated result of turn-on V_{miller}

5. Conclusions

A practical parameter extraction method is provided based on optimization algorithm for the analytical IGBT model. As an example, the identified and validation results of BUP302 are given.

From the results of identification and validation, we can see that the parameters identified are appropriate in a large range of voltage and current. The validation with the experimental results demonstrates the accuracy of the proposed parameter extraction method. The identification is a process of continuous optimization, and this process can be carried out automatically. After the simulation software has been chosen, it can be used conveniently for

common users.

References

- [1] Sheng K., Williams B.W. and Finney S.J. A Review of IGBT Models, IEEE Trans. on Power Electronics, Vol.15, No.6, 2000, pp.1250-1266.
- [2] H.S.Oh and M.A.El-Nokali A new IGBT Behavioral Model. Solid-State Electron., Vol.45, pp.2069-2075, Nov.2001.
- [3] Hefner A. R., Jr. Modeling Buffer Layer IGBTs for Circuit Simulation . IEEE Trans. Power Electron., vol.10,no.3,pp111-123, May 1995.
- [4] A.R.Hefner and D.L.Blackburn, An Analytical Model for the Steady-State and Transient Characteristics of the Power Insulated-Gate Bipolar Transistor, Solid-State Electron., vol.31, no.10, 1988, pp1513-1532.
- [5] A.R.Hefner, Analytical modeling of device-circuit interactions for the power insulated gate bipolar transistor (IGBT), Conf. Rec. Annu. Meeting (IEEE Ind. Appl. Soc.), vol. 35, no. 6, pp. 606–614, 1988.M
- [6] Kang W.Y.,Ahn H. A Parameter Extraction Algorithm for IGBT Behavioral Model IEEE Trans on Power Electronics, Vol.19, No.6, 2004 pp.1365-1371.
- [7] S. Musumeci, A.Raciti and M.Sardo etc “PT-IGBT PSpice Model with New Parameter Extraction for Life-time and Epy Dependent Behavior Simulation” IEEE PESC Annual Mtg. Rec., 1996, pp1682-1688.
- [8] J.Sigg, Purkes and R.Kraus, Parameter Extraction Methodology and Validation for an Electro-Thermal Physics-Based NPT IGBT Model, IEEE IAS Rec. Oct. 1997, pp?/
- [9] A.R.Hefner, Bouche S., Automated Parameter Extraction Software for Advanced IGBT Modeling , Computer in power electronics 2000 . COMPEL 2000, the 7th workshop, 16-18, July 2000. pp10-18.
- [10] Bryant, A.T.; Xiaosong Kang; Santi, E.; Palmer, P.R.; Hudgins, J.L.; Two-Step Parameter Extraction Procedure With Formal Optimization for Physics-Based Circuit Simulator IGBT and p-i-n Diode Models, IEEE Transactions on Power Electronics, Vol. 21, No. 2, Mar. 2006