

PHILOSOPHICAL TRANSACTIONS  
OF THE  
ROYAL SOCIETY OF LONDON.

SERIES A, VOL. 230. Pp. 323-362.

---

THE PLASTIC DISTORTION OF METALS.

BY

G. I. TAYLOR, F.R.S.,  
YARROW RESEARCH PROFESSOR,

AND

H. QUINNEY, M.A.

PRINTED AND PUBLISHED FOR THE ROYAL SOCIETY BY  
HARRISON AND SONS, LTD., 44-47, ST. MARTIN'S LANE, LONDON, W.C. 2,  
Printers in Ordinary to His Majesty.

1931.

*Price Five Shillings.*

A 689.

13.11.31.

## PUBLICATIONS OF THE ROYAL SOCIETY OF LONDON.

ABSTRACTS of the PAPERS printed in the PHILOSOPHICAL TRANSACTIONS of the ROYAL SOCIETY of LONDON. Vols. 1 to 6 (1800-1854), 8vo, at 10s. each. (Vols. 3, 4 and 6 out of Print.)

PROCEEDINGS of the ROYAL SOCIETY of LONDON, being a continuation of the foregoing Series. Vols. 8 to 14, and 16 to 74, 21s. each, cloth. Vol. 75 is composed of Obituary Notices of Fellows Deceased, 1898-1904. Price 15s. With Vol. 76 the "Proceedings" appear in enlarged form and in two series, viz.—A, Mathematical and Physical, and B, Biological; bound cloth, gilt lettered, price 25s. per Vol.

Commencing with Series A, Volume 129, and Series B, Volume 107, the price of the Cloth-bound Volumes is increased to 35s. each. Subscription price, payable in advance of publication, of the numbers comprising the Volumes of Series A and Series B, 30s. per Volume.

### A GENERAL INDEX TO THE PROCEEDINGS OF THE ROYAL SOCIETY.

Vols. 1-75. Covering the Period 1800-1905 (under authors' names). Price 5s. Half-price to Fellows of the Society.

### THE YEAR-BOOK OF THE ROYAL SOCIETY, 1931.

Principal Contents:—List of Fellows, Committees, &c.; Statutes and Regulations; Business of the Society during 1930, including Anniversary Meeting, Council's Report, and Treasurer's Accounts; Arrangements for 1931. Demy 8vo, pp. 230. Price 7s. 6d.

### THE ATOLL OF FUNAFUTI,

#### BORINGS INTO A CORAL REEF AND THE RESULTS.

Royal 4to. 428 pages, with numerous Plates and Diagrams, and Separate Portfolio of Geological Maps and Sections. Price 30s. To Fellows of the Royal Society, 20s.

### REPORT TO THE GOVERNMENT OF CEYLON

ON THE

### PEARL OYSTER FISHERIES OF THE GULF OF MANAAR.

By W. A. HERDMAN, D.Sc., F.R.S.

(With Supplementary Reports upon the Marine Biology of Ceylon by various Naturalists.)  
Parts I.-V., 1903-1906. Royal 4to. 20s. each. To Fellows of the Royal Society, 15s. each.

### THE SCIENTIFIC WORK OF THE LATE SPENCER PICKERING, F.R.S.

By Prof. T. M. LOWRY, F.R.S., and Sir JOHN RUSSELL, F.R.S.

With a Biographical Notice by Prof. A. HARDEN, F.R.S.

Cloth gilt. Price 4s.

### FOOD (WAR) COMMITTEE

#### REPORT ON THE FOOD REQUIREMENTS OF MAN, AND THEIR VARIATIONS ACCORDING TO AGE, SEX, SIZE AND OCCUPATION.

Fcap. folio. Price 1s. 6d.

#### REPORT ON THE COMPOSITION OF POTATOES GROWN IN THE UNITED KINGDOM.

Fcap. folio. Price 2s.

Published for the ROYAL SOCIETY by HARRISON AND SONS, LTD., 44-47, St. Martin's Lane, London, W.C. 2.

IX. *The Plastic Distortion of Metals.*

By G. I. TAYLOR, F.R.S., *Yarrow Research Professor*, and H. QUINNEY, M.A.

(Received May 12, 1931—Read June 25, 1931.)

THE plasticity of metals has been the subject of many recent papers but, owing to the complexity of the subject, there is but little agreement between different researches. Attempts to extract simple generalisations from the very complex phenomena have been made chiefly in two directions (1) Engineers have used test bars of certain specially simple form, such as uniform round bars which they have subjected to twisting or tension, and they have found the effect on their test of varying physical conditions. (2) Mathematicians have assumed an ideal plastic material and have given it properties which may or may not be possessed by some real material. They have then analysed the distributions of stress and strain when this ideal material is subjected to given external forces or distortions.

The main problem in plasticity is to determine the internal stresses and strains in a plastic body when given external loads and strains are applied to its outer surfaces. The common engineering tests are incapable of supplying information in any conditions of stressing except those under which the particular test concerned was carried out, thus a pure tensile test of an annealed copper bar yields a load-extension curve in which the true elastic limit is extremely low, the load rapidly increases, with plastic extension. A twisted bar yields a torque-angle curve of the same type and the relationship between these two curves is a specially simple example of the type of problem which must be investigated before it will be possible to analyse the internal stresses and strains in any of the more complex problems of plastic distortion, such for instance as that of analysing the internal stresses during the drawing of a wire through a draw plate. To connect tests made with different types of loading it is necessary to develop some theory of plasticity which takes account of the most essential observed properties of plastic materials but leaves out of consideration those which appear to be of less importance in connection with the particular set of phenomena under discussion. Thus it happens that a theory which affords a useful means of representing plastic phenomena in a steel which has a high elastic limit may concern itself with the conditions at the elastic limit, defined as the stress at which the first deviation from perfect elasticity is observable. For copper, however, the elastic limit is very low indeed, even after it has been hardened by cold working. On the other hand, if a gradually increasing load of any type is applied to annealed copper the distortion increases and if the load stops increasing the distortion

stops increasing, except for a very small increase which occurs at the highest loads which copper can maintain. This increase is, however, too small to affect any of the results given in this paper, so that at any stage of the process the metal may be said to have a definite strength with regard to the particular type of stress which is being applied. If the load be removed and gradually applied again, plastic distortion begins at a load which is considerably lower than the maximum load applied during the first loading, but the distortion remains very small till the highest load applied in the first loading is reached. It then begins to increase rapidly and after quite small distortion during the earliest stages of the second loading it has a strength which is identical with that which it would have had if it had been loaded in one operation without the intermediate unloading.

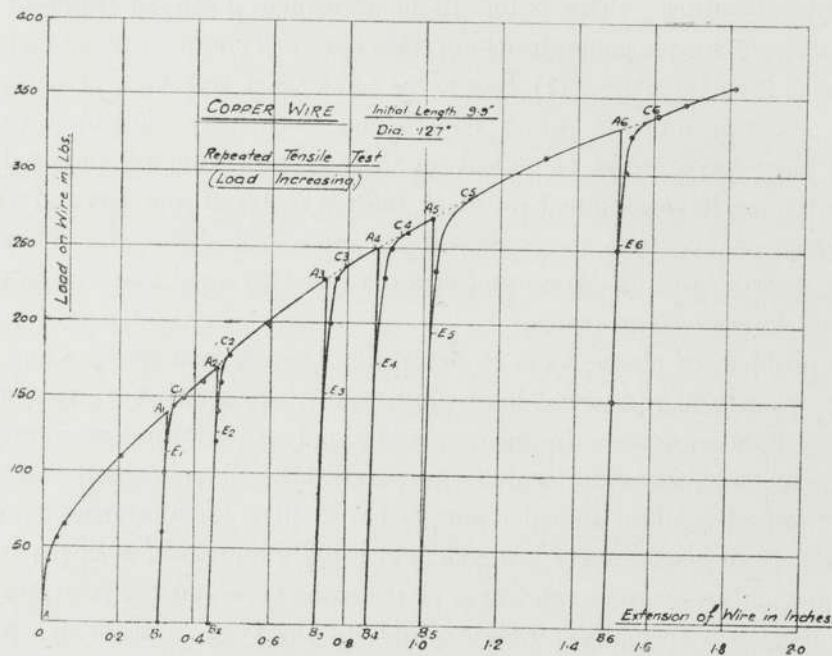

FIG. 1.

This is represented in the curve, fig. 1, which shows the load-extension curve for an annealed copper wire. At the points  $A_1, A_2 \dots$  the loads were removed and gradually replaced. The stress strain curves during the removal of the load are shown as  $A_1B_1, A_2B_2 \dots$ . They correspond with an elastic contraction. The reloading curves are shown as  $B_1E_1C_1A_2, B_2E_2C_2A_3 \dots$  while the result of testing another piece of the same wire without unloading at  $B_1B_2 \dots$  is shown as the continuous curve  $AA_1C_1A_2C_2 \dots$ . The parts  $A_1C_1, A_2C_2$  where the curve for a continuously increasing load does not coincide with that for the unloaded and reloaded wire are shown dotted in fig. 1. It will be seen that on reloading a small but finite plastic distortion represented by the horizontal projection of the dotted portion  $AC$  must be given to the metal before it attains the same strength on the test piece which was never unloaded.

We thus distinguish two points on each reloading curve (*i*) the elastic limit represented by the points  $E_1$   $E_2$  in fig. 1 and (*ii*) the points  $C_1$   $C_2$  ... where the reloading curve joins or becomes parallel to the load-extension curve for continuously increasing load. The points  $E_1$   $E_2$  do not seem to be very well defined, but we may define the strength of the material under direct tension at the beginning of the second loading as the ordinate at which the curve  $A_2$   $C_1$  would, if produced backwards, cut the vertical corresponding with the length of the specimen at the beginning of the second loading. Since the curve  $A_2$   $C_1$  when produced backwards is found as shown in fig. 1 to pass through the point  $A_1$ , this definition ensures that the strength of the material at the beginning of the second loading shall be the same as that at the end of the first loading.

This interpretation of the strength of a plastic material makes it possible to compare the strengths of the material when subjected to different distributions of stress. To compare the strength of a circular tube in torsion with the strength under a direct load one may first load the tube till the extension has some definite value, then remove the load and start twisting. The torque-angle curve will be found to be similar to the part  $B_1E_1C_1$   $A_2$  of the curve in fig. 1 which corresponds to the second loading. It has a very rapid rise corresponding with  $B_1E_1C_1$  (fig. 1) followed by a gradual rise corresponding with  $C_1$   $A_2$ . The torque to be compared with the direct load at the end of the first loading of the tube is that found by producing the second part of the torque-angle curve backwards till it cuts the axis of zero angle. This process sounds rather artificial but in actual operation it is very simple. The curves, figs. 6, *a*, *b*, *c*, are actual examples, the produced portions of the curves being shown dotted. It will be seen that in every case the early part of the curve is so steep compared with the succeeding portion which corresponds with  $C_1$   $A_2$  of fig. 1 that there is little latitude for possible variation in the extrapolated torque corresponding with zero angle of twist.

The method just described for defining the strength of plastic materials is essentially the same as that used by LODE in his work on the plasticity of soft metals. It applies well to copper and annealed iron and to mild steel, but in the case of aluminium there is in many cases an appreciable creep or gradually increasing strain with constant stress. Under these conditions the stress-strain curve is not unique, but it is still possible to discuss the relationship between the distortions produced by various distributions of stress because on reloading a specimen after removing the initial load in the way previously described for copper (see fig. 1) the load at which a rapid increase in strain occurs is definite even though a slow creeping begins at a lower load.

After defining the strength of the material in this way we are in a position to compare the behaviour of real materials with an ideal isotropic plastic body which has the property that the resistance to distortion bears a definite relationship to the total amount of distortion from the initial annealed condition. A complete specification of the properties of such a material must include (1) the particular function of the stress components which must rise to a certain value (which defines the strength of the material) before plastic flow begins; (2) the relationship between the plastic distortion produced and

the type of applied stress ; (3) the relationship between the amount of distortion (cold work) and the resistance to further distortion. Of these (1) has been the subject of many researches which have resulted in the announcing of several mutually incompatible laws, the best known of which are (a) the hypothesis known as GUEST'S law or MOHR'S hypothesis that the maximum shear stress determines the beginning of plastic flow independently of the other components of shear stress, and (b) VON MISES' hypothesis that the sum of the squares of the principal shear stresses must rise to a given value before plastic distortion begins. This we will call VON MISES' first hypothesis to distinguish it from another which will be discussed later.

On the other hand (2) a knowledge of which is quite as necessary as (1) in many problems of plasticity has received but little attention. The reason for this neglect is, no doubt, that in the case of the simplest tests which can be applied to an isotropic or plastic material, the density of which is unaltered by strain, the type of distortion which occurs is simply a matter of symmetry, thus the only possible distortion of a uniform tube under pure tension is a uniform extension parallel to its axis, together with a uniform contraction of the material equal to half the extension in all directions at right angles to the axis. In the case of a twisted tube the distortion must be a pure shear which transforms generators of the tube into spirals without altering its external shape or dimensions. If, however, these two types of stressing are combined, a tube being subjected to direct tensile load and to torsion simultaneously, symmetry alone is not sufficient to determine the resulting distortion, and it is by the use of tests of this kind that we have investigated the relationship between distortion and stress distribution.

*General Theory of Relationship between Stress and Strain in a Plastic Solid.*

*Specification of Stress.*—The mathematical specification of stress in a solid is discussed in all books on elasticity. It can most simply be represented by means of a stress quadric\* which is so placed that its principal axes are in the direction of the principal stresses, so that the components of shear stress parallel to the principal planes are zero. The principal shear stresses  $\tau_1$   $\tau_2$   $\tau_3$  are defined as the shear stresses parallel to the planes which pass through one of the principal stress axes and are at  $45^\circ$  to the other two. The stress acts in the direction at right angles to the principal stress axis which lies in the plane concerned. If  $\sigma_1$ ,  $\sigma_2$ ,  $\sigma_3$  are the principal stresses then

$$\tau_1 = \frac{1}{2} (\sigma_2 - \sigma_3), \quad \tau_2 = \frac{1}{2} (\sigma_3 - \sigma_1), \quad \tau_3 = \frac{1}{2} (\sigma_1 - \sigma_2).$$

The importance of the principal shear stresses lies in the fact that it is found experimentally that the addition of a total hydrostatic pressure to any stress system does not produce any plastic strain. This depends only on the shear stresses. The addition of a constant pressure to  $\sigma_1$ ,  $\sigma_2$  and  $\sigma_3$  leaves  $\tau_1$ ,  $\tau_2$  and  $\tau_3$  unaffected so that  $\tau_1$ ,  $\tau_2$ ,  $\tau_3$  are sufficient to define the stress system so far as plastic distortion is concerned ; and since

\* LOVE'S 'Elasticity,' 4th ed., § 50.

$\tau_1 + \tau_2 + \tau_3 = 0$ , the direction and magnitude of two of the principal shear stresses are sufficient to define the stress at any point. The equation to the stress quadric when referred to the principal axes of stress is

$$\sigma_1 x^2 + \sigma_2 y^2 + \sigma_3 z^2 = \text{constant} \dots \dots \dots (1)$$

*Specification of Strain.*—Any small strain may be represented by a strain quadric\* which is a surface possessing the property that the reciprocal of the square of its central radius vector in any direction is proportional to the extension of a line in that direction. The principal planes of this quadric are so orientated that there is no component of shearing strain parallel to them. The equation of the strain quadric referred to its principal axes is

$$e_1 x^2 + e_2 y^2 + e_3 z^2 = \text{constant} \dots \dots \dots (2)$$

where  $e_1, e_2, e_3$  are the (small) extensions in the directions of the principal axes. In the case of materials which do not change their density during distortion

$$e_1 + e_2 + e_3 = 0.$$

*Directional Relationship between Stress and Strain.*—All experiments on the plasticity of metals which we have been able to find recorded have been carried out under conditions in which symmetry alone ensures that the directions of the principal axes of stress shall be identical with those of strain. Thus in the case of a uniform bar extended by a direct load the stress and strain quadrics are both spheroids with the principal axis of revolution in the direction of the axis of the bar. In all theories of plastic flow in isotropic solids such as that of LEVY and VON MISES' it has been assumed without experimental test and sometimes without any explicit statement that the directions of the principal stresses are identical with those of principal strains. It is difficult to imagine any other relationship between these directions, but it is worth while noticing that any departure from isotropy in the material might be expected to falsify this relationship unless, as in the case of a drawn metal rod or tube under direct load, the directions of principal stress are identical with the principal directions of the non-isotropic properties. In the work which will be described later, experiments are carried out in which the directions of the principal stresses are variable at will and it is proved experimentally that the directions of the axes of the stress quadric do in fact coincide with those of the strain quadric.

*Other Relationships between Stress and Strain.*—When the directions of the principal axes of stress are known the complete specification of stress contains two variables, which may be regarded as (1) the absolute magnitude of any one of the principal shear stresses or of any homogeneous function of them, and (2) any one ratio between the principal shear stresses or between linear combinations of them. The same remarks

\* LOVE's 'Elasticity,' 4th ed., § 11.

apply to the specification of strain. When there is no change of density and the directions of the principal axes are known, two variables only are needed for the complete specification of any small strain. These variables will now be considered separately.

1. (a) *Absolute Magnitude of Stress*.—With a plastic body of the type here considered a definite stress is required to produce a small plastic strain, and various empirical laws have been put forward to represent the strength of the material to resist different types of stress; thus according to MOHR'S hypothesis or GUEST'S law, plastic strain takes place when the absolute value of either  $\tau_1$  or  $\tau_2$  or  $\tau_3$  rises to a certain value  $\kappa$ . According to the first hypothesis of VON MISES, plastic strain begins when  $\tau_1^2 + \tau_2^2 + \tau_3^2$  rises to the value  $2\kappa^2$ . In either case  $\kappa$  is defined as half the lowest direct stress at which a tensile specimen can be extended plastically. On applying these empirical laws to the case of a tube twisted by application of a torque after the value of  $\kappa$  has been determined by a direct tensile test it will be seen that according to MOHR'S hypothesis the greatest of the principal shear stresses in torsion should be  $\kappa$ , while according to that of VON MISES' it should be  $2\kappa/\sqrt{3}$ . The comparison between the strengths of tubes under direct load and under torsion therefore affords a means of comparing these theories. The experiments to be described later verify the substantial accuracy of VON MISES' hypothesis in the case of copper and aluminium, not only in the case of the particular stress distribution of a twisted tube, but for all ratios of the principal shear stresses.

1. (b) *Absolute Magnitude of Strain*.—The absolute magnitude of the strain when any given stress is applied depends on the rate of increase in strength of the material with increasing strain. This varies very widely with the material, and for the present at any rate we may without loss of interest regard it as indeterminate.

2. For any given material the ratio of any pair of principal shear stresses may be regarded as a definite function of the ratio of the corresponding shear strains. VON MISES has proposed the law that these ratios are always equal to one another as can be proved to be the case for a viscous fluid. This hypothesis will be called VON MISES' second hypothesis. It is worth noticing that if the stress system be reduced by addition or subtraction of a uniform hydrostatic pressure to one in which  $\sigma_1 + \sigma_2 + \sigma_3 = 0$  VON MISES' second hypothesis may be completely expressed by the statement that the stress quadric is similar and similarly orientated to the strain quadric.

#### *Work of LODE.*

The only work in which these theories have been put to the test of experiment seems to be that of LODE\* who tested thin-walled metal tubes under direct load when subjected simultaneously to internal pressure. By varying the ratio of the internal pressure to

\* "Versuche über den Einfluss der Mittleren Hauptspannung auf das Fließen der Metalle Eisen Kupfer und Nickel," 'Z. Physik,' vol. 36, p. 913 (1926).



the direct load he was able to obtain all possible ratios of the principal shear stresses and by measuring the extension and also change in the diameter of the tube he was able to measure the ratios of the corresponding principal shear stresses. It has already been pointed out that the ratio of any two independent linear combinations of shear stresses can be used to define the stress. The particular combination used by LODE was

$$\mu = 2 \left( \frac{\sigma_2 - \sigma_3}{\sigma_1 - \sigma_3} \right) - 1,$$

and the corresponding variable for defining the strain was

$$\nu = 2 \left( \frac{e_2 - e_3}{e_1 - e_3} \right) - 1$$

where  $e_1$  was the extension of the material in the direction of the length of the tube,  $e_3$  was that in the direction of the radius and  $e_2$  was the tangential extension obtained by measuring the change in mean radius of the tube. According to VON MISES' second theory the relationship  $\mu = \nu$  should hold.

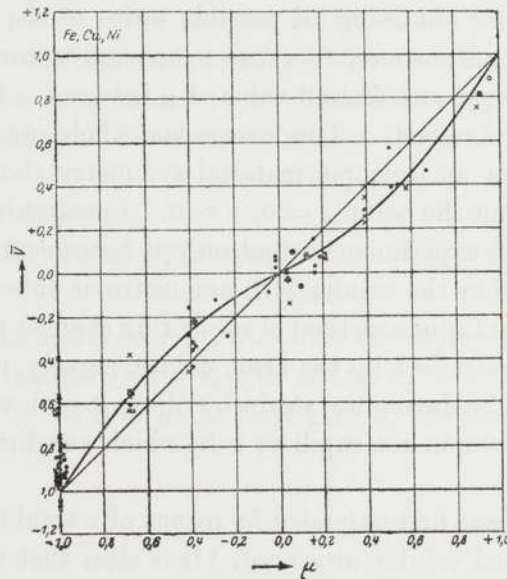

FIG. 2.

LODE's results are shown in fig. 2 where the ordinates represent  $\nu$  while the abscissæ are  $\mu$ . Since LODE's tubes were thin-walled the stress  $\sigma_2$  may be considered as great compared with  $\sigma_3$  and LODE took  $\sigma_3 = 0$ , so that  $\mu = 2\sigma_2/\sigma_1 - 1$ . When there was no internal pressure  $\sigma_2 = 0$ , so that  $\mu = -1$ , and as  $\sigma_2$  increased  $\mu$  increased from  $-1$  through zero till when  $\sigma_2 = \sigma_1$ ,  $\mu = +1$ . Further increases in  $\sigma_2$  were not considered because in an isotropic material it is sufficient to limit the range of experiment to cases for which  $\sigma_1 > \sigma_2 > \sigma_3$ .

For an isotropic material the stress quadric degenerates into a spheroid when

$$\mu = -1, 0 \text{ or } +1,$$

so that symmetry alone necessitates that  $\mu = \nu$  at those three points.

On examining LODE's diagram, fig. 2, it will be seen that some of the experimental points, particularly for  $\mu = -1$ , which correspond with direct tension in the absence of internal pressure, do not satisfy this condition so that either there is a considerable possible error in the measurements or else the tubes were not isotropic. In spite of the fact that the probable error appears to be of about the same order as the effect measured LODE's results seem to show a distinct tendency for the absolute value of  $\nu$  to be less than that of  $\mu$ .

In view of the uncertainty so clearly shown in LODE's diagram, fig. 2, it cannot be definitely stated whether VON MISES' hypothesis that  $\mu = \nu$  is true or untrue, it was largely to find out whether another method could be devised to give more reliable results that the work here described was undertaken.

#### *Method of the Present Work.*

The method adopted for obtaining all possible ratios of the principal shear stresses was to subject a tube simultaneously to a direct load and to torsion. By adjusting the ratio of direct load to torque any desired value of  $\mu$  between  $-1$  for no torque and  $0$  for no direct load could be obtained. This covers the whole range of ratios of principal shear stresses because for an isotropic material symmetry shows that the  $\mu, \nu$  curve must be symmetrical about the point  $\mu = 0, \nu = 0$ . In searching for the most probable sources of error in LODE's experiments attention was concentrated first on testing tubes for want of isotropy so that the results with non-isotropic tubes could be rejected, and secondly on improving on LODE's method of measuring changes in diameter of the tubes. Both these objects were attained by the same device, namely, measuring the change in internal volume of the tube during the strain by filling it with water and measuring the movement of the water column in a capillary tube which was directly connected with the tube under test.

Each tube under test was first extended by means of a total load  $W$ , applied directly, and the change in internal volume measured. It is clear that when a tube of isotropic material, which does not change its density under strain, is stretched there should be no change in internal volume, because each element of the wall of the tube contracts equally in all directions at right angles to its length, so that the ratio of the internal to external diameter will remain unchanged. Hence the ratio of the volume of the bore (*i.e.*, the space inside the inner surface of the tube), to that of the material of the tube (*i.e.*, the space between the walls of the tube) remains unchanged, and consequently since the change in density is assumed zero the internal volume must remain unchanged by the stretching. After any end effects have been eliminated any change in internal volume on stretching by a direct load indicates either that the material is not isotropic

or that there is an appreciable change in density on stretching. The change in density can be measured independently and in the case of copper and aluminium it is found to be very small. The change in internal volume which results from the small measured change in density can be calculated, and if for any particular tube the observed change in internal volume was found to be much greater than this (as sometimes occurred under special heat treatment) the tube was rejected.

The load was next partially removed till a fraction  $mW$  ( $0 < m < 1$ ) remained and a gradually increasing torque applied, the angle of twist and the extension being measured. The torque-angle curve and the twist-extension curve were thus obtained, specimens of these are given in fig. 7, *a, b, c*. At the same time the change in internal volume was measured and expressed in terms of the extension. Specimens of the resulting curves are shown in fig. 8.

By varying  $m$  from 0 to 1 these measurements make possible: (i) a comparison between the strength of the material under direct load and that under any other ratios of shear stresses, so that VON MISES' first hypothesis can be compared with that of MOHR and GUEST, (ii) a verification that the orientations of the principal axes of stress coincide with those of strain, (iii) measurements of  $\nu$  in terms of  $\mu$ , and hence a test of VON MISES' second hypothesis that  $\mu = \nu$ . The method is particularly suitable for testing whether  $\mu = \nu$ , because if  $\mu = \nu$  the internal volume remains unchanged whatever combination of direct load and torque is applied. Hence the measured changes in internal volume afford a means of making a direct measurement of deviations from the expected relationship.

*Analysis of Stress and Strain in a Thin-walled Tube subjected to Combined Direct Load and Torque.*

To represent the stress and strain quadrics axes through any point in the material of the tube are taken,  $x$  parallel to the length of the tube,  $y$  tangential,  $z$  radial. The scheme is shown in fig. 3. If  $mW$  is the total load,  $r_m$  the mean radius of cross section

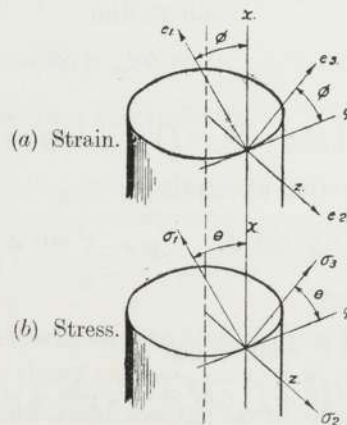

FIG. 3.

of the tube,  $t$  its thickness,  $G$  the applied torque, the stress system is represented in the usual notation by

$$\left. \begin{aligned} X_x = m P_0 = P = \frac{mW}{2\pi r_m t}, \quad Y_y = 0, \quad Z_z = 0 \\ X_y = S = \frac{G}{2\pi r_m^2 t}, \quad Y_z = 0, \quad Z_x = 0 \end{aligned} \right\} \dots \dots \dots (3)$$

where  $P_0$  is the stress in the material at the end of the first loading,  $P$  is the stress in the direction of the length of the tube during the combined stress, and  $S$  is the shear stress.

We may suppose that a length  $l_0$  of the material is first stretched to length

$$l = l_0 (1 + e_0)$$

by direct load. Next, owing to the action of the combined direct load  $mW$  and torque  $G$  the tube stretches to length  $l + \delta l$  and twists through an angle  $\chi$ . This strain may be represented by the components

$$\left. \begin{aligned} e_{xx} = e, \quad e_{yy} = -\frac{1}{2}e - f, \quad e_{zz} = -\frac{1}{2}e + f \\ e_{xy} = s, \quad e_{yz} = 0, \quad e_{zx} = 0 \end{aligned} \right\} \dots \dots \dots (4)$$

The extension

$$e = \delta l/l = \delta l/l_0 (1 + e_0).$$

The shear  $s = r_m \chi/l$  and since the material does not change in density during the extension from  $l_0$  to  $l$ ,  $r_m = r_{m0} (1 + e_0)^{-\frac{1}{2}}$ , where  $r_{m0}$  is the mean radius of the tube before the first stretching. Hence

$$s = r_{m0} l_0^{-1} (1 + e_0)^{-\frac{1}{2}} \chi. \dots \dots \dots (5)$$

As has already been pointed out if the density and internal volume of the tube do not change  $e_{yy} = e_{zz} = -\frac{1}{2}e$  so that the strain  $f$  in (4) is proportional to the change in internal volume, in fact

$$\begin{aligned} \frac{\text{change in internal volume}}{\text{internal volume of tube}} &= 2 \frac{\text{change in radius}}{\text{mean radius}} + \frac{\text{change in length}}{\text{length}} \\ &= 2e_{yy} + e = -2f. \dots \dots \dots (6) \end{aligned}$$

The strain quadric is

$$ex^2 - (\frac{1}{2}e + f)y^2 - (\frac{1}{2}e - f)z^2 + sxy = \text{constant}. \dots \dots \dots (7)$$

To find the direction of its principal axes put

$$x = x' \cos \phi - y' \sin \phi, \quad y = x' \sin \phi + y' \cos \phi. \dots \dots \dots (8)$$

The strain quadric then becomes

$$\begin{aligned} x'^2 \{e \cos^2 \phi - (\frac{1}{2}e + f) \sin^2 \phi + s \sin \phi \cos \phi\} \\ + y'^2 \{e \sin^2 \phi - (\frac{1}{2}e - f) \cos^2 \phi - s \cos \phi \sin \phi\} \\ + x' y' \{-(\frac{3}{2}e + f) \sin 2\phi + s \cos 2\phi\} - (\frac{1}{2}e - f) z^2 = 0. \dots \dots \dots (9) \end{aligned}$$

The strain quadric is now referred to its principal axes if the coefficient of  $x'y'$  is zero, *i.e.*, if

$$\tan 2\phi = s/(\frac{3}{2}e + f) \dots \dots \dots (10)$$

and substituting this value of  $\phi$  in the coefficients of  $x'^2$  and  $y'^2$  in (9) the principal extensions are found to be

$$\left. \begin{aligned} e_1 &= \frac{1}{4}e - \frac{1}{2}f + (\frac{3}{4}e + \frac{1}{2}f) \sec 2\phi \\ e_3 &= \frac{1}{4}e - \frac{1}{2}f - (\frac{3}{4}e + \frac{1}{2}f) \sec 2\phi \\ e_2 &= -\frac{1}{2}e + f \end{aligned} \right\} \dots \dots \dots (11)$$

It will be noticed that  $e_1 > e_2 > e_3$ . The directional relationships between these quantities are shown in fig. 3a.

Using LODE's variable

$$v = 2 \left( \frac{e_2 - e_3}{e_1 - e_3} \right) - 1$$

it will be found that

$$v = \left( \frac{-1 + 2f/e}{1 + \frac{2}{3}f/e} \right) \cos 2\phi. \dots \dots \dots (12)$$

The stress quadric is

$$Px^2 + 2Sxy = \text{constant} \dots \dots \dots (13)$$

and substituting

$$x = x' \cos \theta - y' \sin \theta, \quad y = x' \sin \theta + y' \cos \theta$$

this becomes

$$\begin{aligned} x'^2 (P \cos^2 \theta + 2S \cos \theta \sin \theta) + y'^2 (P \sin^2 \theta - 2S \cos \theta \sin \theta) \\ + 2x'y' \{-P \cos \theta \sin \theta + S(\cos^2 \theta - \sin^2 \theta)\} = \text{constant}. \dots \dots (14) \end{aligned}$$

If  $\theta$  is now chosen so that  $x'y'$  are principal axes of stress, the coefficient of  $x'y'$  in (14) is zero so that

$$\tan 2\theta = 2S/P. \dots \dots \dots (15)$$

The principal stresses are then

$$\sigma_1 = \frac{1}{2} P (1 + \sec 2\theta), \quad \sigma_2 = 0, \quad \sigma_3 = \frac{1}{2} P (1 - \sec 2\theta). \dots \dots (16)$$

The directions of these stresses are shown in fig. 3b. LODE's variable

$$\mu = 2 \frac{\sigma_2 - \sigma_3}{\sigma_1 - \sigma_3} - 1$$

is found from (16) to be

$$\mu = -\cos 2\theta. \dots \dots \dots (17)$$

Comparing (6), (12) and (17) it will be seen that if there is no change in internal volume of the tube during distortion so that  $f = 0$ ,  $v = -\cos \phi$ , and if in addition the directions of the principal axes of stress and strain are the same so that  $\theta = \phi$ , then  $\mu = v$ . Thus after verifying experimentally that  $\theta = \phi$ , as is done later in Table II, the observed

change in internal volume is a measure of the deviation from VON MISES' relationship in accordance with the equation

$$\frac{v}{\mu} = \frac{1 - \frac{2f}{e}}{1 + \frac{2f}{3e}}$$

*Relationship between  $m$  and  $S/P_0$  according to MOHR'S and VON MISES' Hypotheses.*

It seems clear that when  $m$  is nearly equal to 1, so that the direct load is only slightly reduced after the first stretching, a small torque will suffice to cause plastic distortion. When  $m = 0$ , so that there is no direct load, as we have already seen  $S/P_0 = 0.5$  according to MOHR'S hypothesis that the maximum principal shear stress alone determines whether plastic distortion shall occur, and  $S/P_0 = 1/\sqrt{3}$  according to VON MISES' hypothesis. To calculate the intermediate values we may use the expressions for  $\sigma_1, \sigma_2, \sigma_3$  given in (16). According to MOHR'S hypothesis  $\sigma_1 - \sigma_3 = P_0$  so that from (16)  $\sigma_1 - \sigma_3 = P \sec 2\theta = P_0$  and  $P/P_0 = m$ , so that

$$m = \cos 2\theta \quad \dots \dots \dots (18A)$$

and since  $2S/P = \tan 2\theta$ ,

$$S/P_0 = \frac{1}{2}m \tan 2\theta = \frac{1}{2}m \left( \frac{1}{m^2} - 1 \right)^{\frac{1}{2}} = \left( \frac{1 - m^2}{4} \right)^{\frac{1}{2}} \quad \dots \dots \dots (18B)$$

According to VON MISES' first hypothesis

$$(\sigma_1 - \sigma_2)^2 + (\sigma_2 - \sigma_3)^2 + (\sigma_3 - \sigma_1)^2 = 2P_0^2$$

so that from (16)

$$\frac{1}{4}P^2 (1 + \sec 2\theta)^2 + \frac{1}{4}P^2 (1 - \sec 2\theta)^2 + P^2 \sec^2 2\theta = 2P_0^2$$

or since

$$P = m P_0, m^2 \left( \frac{1}{2} + \frac{3}{2} \sec^2 2\theta \right) = 2 \quad \dots \dots \dots (19A)$$

Hence

$$S/P_0 = \frac{1}{2}m \tan 2\theta = \left( \frac{1 - m^2}{3} \right)^{\frac{1}{2}} \quad \dots \dots \dots (19B)$$

#### *Experimental Details.*

A sketch of the apparatus used is shown in fig. 4. The tube under test which is about  $\frac{1}{4}$  inch external diameter is shown as A. BB are the upper and lower fixings for gripping the ends of the tube. The upper fixing B is supported by a steel ball C on a fixed support by means of a connecting carriage D which is prevented from rotating by fixed stops EE'. A cylindrical drum F, 8 inches diameter, rests on the lower end fixing, B'. The direct load W is attached to this through a steel ball pivot similar to that at the top but not shown in the sketch, and the torque is applied by means of threads passing over ball-bearing pulleys GG' supporting equal weights  $pp$ . The angle of twist is measured by a fixed pointer H reading on a protractor K fixed to the upper surface of the drum F. The change in internal volume is measured by reading the position of the meniscus J

of the water in the capillary tube L on the scale M. The capillary tube is connected with the upper end fixing B and the whole apparatus filled with water through the glass stop-cock O at the lowest point of the lower fixing B'. The extensions are read by telescopes (not shown in fig. 4) mounted on a vertical steel rod. These can be focussed either on fine ring marks QQ on the specimen or on the upper carriage D and on a corresponding steel point R attached to the axis of the lower fixing B' in such a way that it can be centralised so that it remains in focus during the rotation of the drum F.

The chief difficulty in the design of the apparatus lay in making end fixings which would remain watertight when the tube was stretched and at the same time limit to a small area the end effects or variation of the distortion at the end from the uniform

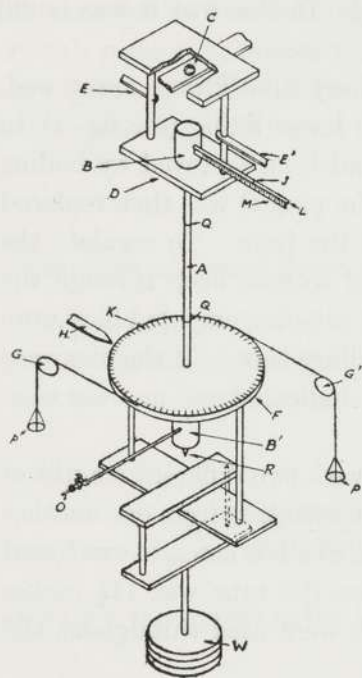

FIG. 4.

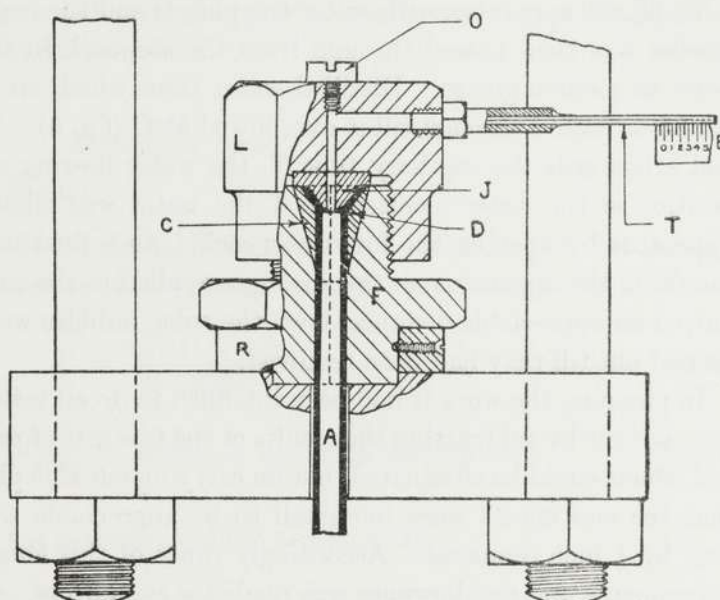

FIG. 5.

state of the middle of the tube. This was accomplished by expanding the ends of the specimens into conical flanges by means of a specially designed press. The ends, so formed, were then gripped in the end fixings BB' of fig. 4. These are shown in detail in fig. 5. In this diagram A is the specimen with its conical ends. C is a steel sleeve (split for convenience) with conical upper and lower faces. J is a conical plug with a central hole to let the water through and a plane upper face which makes a watertight seating in the upper nut L of the fixing. The lower nut F which rests on the carriage is split and threaded with a deep thread so that by screwing the two parts L and F hard together a great pressure can be brought to act on the flanged upper portion of the specimen. The large distortions so produced in the material of the conical flange harden copper, iron and aluminium to such an extent that when the tube is afterwards stretched

no observable plastic flow takes place in the material of the flange. The stretching in fact, begins at the corner D where the flange connects with the parallel part of the tube. The ring R is merely used for holding the two portions of the split nut F in place.

It will be noticed that in this description the sleeve C plays no part, it might, in fact, be part of F, when the apparatus is used in the manner described. When it was used for soft metals like lead and cadmium which do not harden appreciably by cold work it was found that the method just described does not ensure that there shall be no flow inside the material of the flange. In these cases, therefore, a cylindrical steel plug with a small central hole was made to fit the bore of specimen. The flat faces of the split sleeve C were then filed so that when the nut L was screwed home, the soft metal was gripped between the split sleeve C and the cylindrical plug. In this way it was found possible to grip lead tube.

To fill the apparatus with water the plug O and the capillary tube T were unscrewed, alcohol was then passed through from the stopcock in the lower fixing (see fig. 4) in order to remove grease. Distilled water from which air had been removed by boiling was then passed through till it overflowed at O (fig. 5). The plug O was then replaced and afterwards the capillary tube T, the water flowing all the time. To regulate the position of the water meniscus in T the water was allowed to flow back through the apparatus by opening the lower stopcock. As a final test whether any bubbles were caught in the apparatus air pressure was applied to the capillary tube. If the meniscus moved an appreciable distance down the tube, bubbles were indicated and no tests were carried out till they had been removed.

In planning the work it had been intended to do all tests with two different lengths of tube so that by subtracting the results of the two sets of measurements from one another end effects could be eliminated, but on carrying out this plan in a few cases, it was found that the end effects were too small to be appreciable when the tube was  $11\frac{1}{2}$  inches long by  $\frac{1}{4}$  inch diameter. Accordingly tubes of this length were used throughout the experiments and no allowance was made for end effects.

#### *Heat Treatment.*

The copper tubes were supplied in a hardened condition and they were annealed at  $650^{\circ}\text{C}$ . for about 36 hours. This produced grains the linear dimensions of which were small compared with the wall thickness. For comparison we also annealed some tubes after a slight straining at considerably higher temperatures. The large grains thus produced in many cases stretched from the inner to the outer wall, and in these cases we found that the material behaves in regard to distortion as though it were not isotropic. This question is discussed later in connection with fig. 8.

The copper tubes were composed of what the makers described as high conductivity copper, containing not more than 0.2 per cent. impurity. A comparison between the mechanical properties of these tubes and those of electrolytic copper wire of the highest



purity obtainable, commercially, showed us that the small amount of impurity present in our tubes was not sufficient to make them differ appreciably from what might be expected if we had been able to use electrolytic copper throughout.

The aluminium tubes were supplied in a small-grained annealed condition and no heat treatment was required. The aluminium was described by the makers as containing 99.7 to 99.8 per cent. aluminium.

The mild steel was too hard in the condition in which it was supplied. Its carbon content was from 0.12 to 0.18 per cent. It was, therefore, annealed *in vacuo* at about 920° C. In some cases the same mild steel was decarbonised in a stream of hydrogen at 920°. This gave large crystals and the results of our experiments again indicated that the material so treated did not behave in an isotropic manner. To obtain smaller crystals some of the tubes were decarburised at 650° C. for five or six days. These tubes were found to behave more like small-grained copper tubes though they still appeared to be less isotropic in regard to their distortion.

*Numerical Data.*

Diameter of torque drum 8.22 inches.

*Copper Tubes.*— $l_0 = 11.5$  inches, external diameter 0.248 inches,  $t = 0.036$  inches,  $r_{m_0} = 0.106$  inches,\* initial area of section =  $2\pi r_{m_0} t = 0.02395$  sq. inches.

$$P = \frac{mW(1 + e_0)}{0.02395} \dots \dots \dots (20A)$$

$$S = \frac{8.22p(1 + e_0)^{\frac{3}{2}}}{(0.02395)(0.106)} = 3230(1 + e_0)^{\frac{3}{2}} p \text{ lbs. per sq. inch.} \dots \dots (21A)$$

where  $p$  is the weight in lbs. in the scale pans of the torque system

$$\tan 2\phi = \frac{2s}{3e(1 + \frac{2}{3}f/e)} = \frac{2}{3}r_{m_0}(1 + e_0)^{-\frac{1}{2}}(1 + \frac{2}{3}f/e)^{-1}\left(\frac{\chi}{\delta l}\right),$$

or if  $\chi$  is measured in degrees instead of angular measure

$$\tan 2\phi = 0.001234(1 + e_0)^{-\frac{1}{2}}(1 + \frac{2}{3}f/e)^{-1}\left(\frac{\chi}{\delta l}\right) \dots \dots \dots (22A)$$

To connect the reading of the meniscus in the capillary tube with  $f/e$ , the area of cross-section of the capillary is 0.0002607 sq. inches, so that if  $d$  is the increase in the reading

\* It will be seen that  $t$  is not very small compared with  $r_{m_0}$ , calculations were made to find the values of the errors introduced by neglecting  $t$  in comparison with  $r_{m_0}$ , and it was found that in all the formulæ the error depended on neglecting  $(\frac{1}{2}t/r_{m_0})^2$  in comparison with unity. In our tubes  $(\frac{1}{2}t/r_{m_0})^2$  was about 0.01 and we estimate that the maximum error in any of our results which can arise from the neglect of  $(\frac{1}{2}t/r_{m_0})^2$  in comparison with unity is 3 per cent., the average being about 2 per cent.

of the meniscus in the capillary tube expressed in inches when the length of the specimen is increased by  $\delta l$ , then from (6)

$$2f = \frac{0.0002607}{(11.5)(\pi)(0.106)^2} = 0.00065d,$$

and remembering that

$$e = \frac{\delta l}{l_0(1 + e_0)}$$

this gives

$$\frac{f}{e} = 0.0037(1 + e_0) \frac{d}{\delta l} \dots \dots \dots (23A)$$

*Aluminium Tubes.*— $l_0 = 11.5$  inches, external diameter 0.2516 inches,  $t = 0.0352$  inches,  $r_{m0} = 0.1082$  inches, initial area of section 0.0240 sq. inches.

$$P = \frac{mW(1 + e_0)}{0.0240} \dots \dots \dots (20B)$$

$$S = 3190(1 + e_0)^{\frac{3}{2}} p \dots \dots \dots (21B)$$

$$\tan 2\phi = 0.00126(1 + e_0)^{-\frac{1}{2}} \left(1 + \frac{2}{3} \frac{f}{e}\right)^{-1} \left(\frac{\chi}{\delta l}\right) \dots \dots \dots (22B)$$

$$\frac{f}{e} = 0.00355(1 + e_0) \left(\frac{d}{\delta l}\right) \dots \dots \dots (23B)$$

*Iron and Steel Tubes.*— $l_0 = 11.5$  inches, external diameter 0.2487 inches,  $r_{m0} = 0.1054$  inches, initial area of cross-section 0.02507 sq. inches.

$$P = \frac{mW(1 + e_0)}{0.02507} \dots \dots \dots (20C)$$

$$S = 3112(1 + e_0)^{\frac{3}{2}} p \dots \dots \dots (21C)$$

$$\tan 2\phi = 0.001226(1 + e_0)^{-\frac{1}{2}} \left(1 + \frac{2}{3} \frac{f}{e}\right)^{-1} \left(\frac{\chi}{\delta l}\right) \dots \dots \dots (22C)$$

$$= 0.00373(1 + e_0) \left(\frac{d}{\delta l}\right) \dots \dots \dots (23C)$$

*Representation of Results.*

The results of the measurements can best be presented in the form of curves showing the relationship between various pairs of simultaneous measurements.

*Torque-extension.*—The torque-extension curves for copper are given for various values of  $m$  in fig. 6, *a*, for aluminium fig. 6, *b*, for mild steel and decarburised iron in fig. 6, *c*. It will be seen that in all cases except two the second or slowly rising portion has been produced backwards in a broken line to the axis to obtain the virtual value

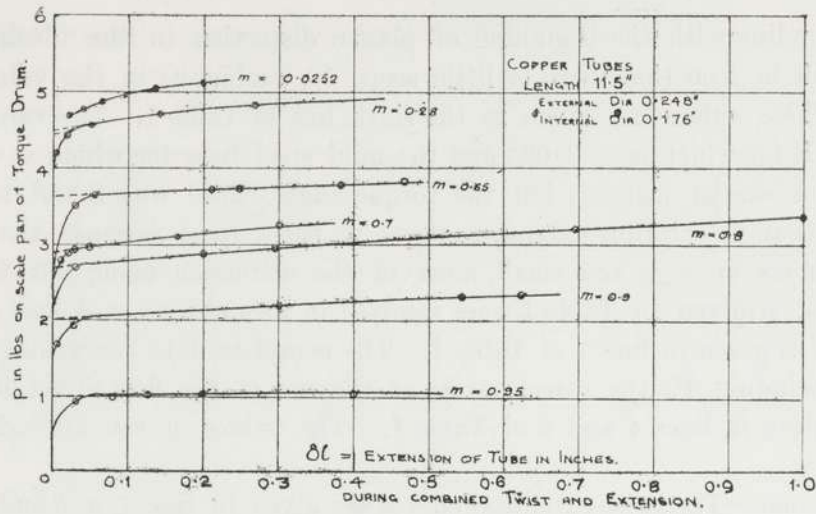

Fig. 6a.—Copper Tubes.

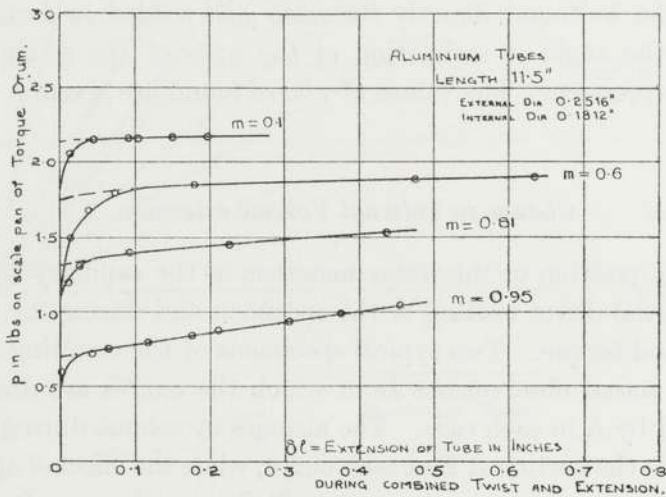

Fig. 6b.—Aluminium Tubes.

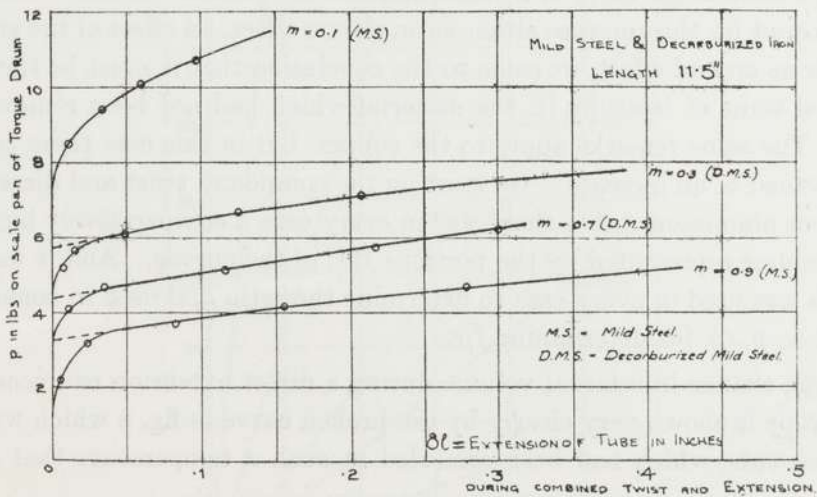

Fig. 6c.—Mild Steel and Decarburised Iron.

of  $p$  corresponding with the beginning of plastic distortion in the idealised plastic body. It will be seen that there is little scope for ambiguity in the values of  $p$  so obtained. These values are given in the sixth line of Table I. The values of  $p$  for copper tube E for which  $m = 0.025$  and the mild steel tube for which  $m = 0.1$  were obtained in a similar manner, but the torque-angle curve was found to be more satisfactory than the torque-extension curve in these cases because the extension for small values of  $m$  is too small, most of the distortion being due to twisting. The values of  $p$  given in Table I were inserted in formulæ 21,  $a$ ,  $b$  and  $c$  to obtain the values of  $S$  given in line 7 of Table I. The complete data concerning the initial stretching including  $P_0$  the direct stress at the end of the first direct loading and  $1 + e_0$  are given in lines 4 and 5 of Table I. The values of  $\tan 2\theta = 2S/mP_0$  are given in line 8.

*Twist-extension.*—The twist-extension curves are given in figs. 7,  $a$ ,  $b$  and  $c$ . It will be seen that in all cases the observed points fall remarkably well on straight lines. From these lines can be found directly the ratio  $\chi/\delta l$  needed in formulæ (22, A, B, C) for calculating  $\phi$ , the angle of inclination of the axes of the strain ellipsoid to the centre lines of the specimen. The values of  $\chi/\delta l$  so found are given in line 9 of Table I.

#### *Change in Internal Volume-extension.*

In every test the position of the water meniscus in the capillary tube was recorded both during the initial direct loading of the specimen and during the subsequent combined direct load and torque. Two typical specimens of the resulting curves are shown in fig. 8 with the actual observations from which the curves are drawn. The initial state is represented by A in each case. The changes in volume during the initial direct loading are shown in the portion A B of each curve, while the effect of applying combined torque and direct load is shown in the portion B C in each case. It will be seen that in the case of aluminium there is a small increase in internal volume. Since we were unable to account for this increase either as an elastic effect, an effect of the small change in density, or as an end effect, we came to the conclusion that it must be the result of a small residual want of isotropy in the material which had not been removed by heat treatment. The same remarks apply to the copper, but in this case there is a decrease in volume instead of an increase. On starting the compound twist and direct load with copper, iron or aluminium tubes there was in every case a comparatively large decrease in internal volume represented by the portions B C of the curves. And it was the slope of B C which was used in every case to determine the ratio  $d/\delta l$  used in connection with formulæ (23, A, B, C), for determining  $f/e$ .

That a large change in internal volume during a direct extension can occur owing to want of isotropy is shown very clearly by the broken curve in fig. 8 which was obtained with a copper tube which had been annealed at such a temperature that the crystal

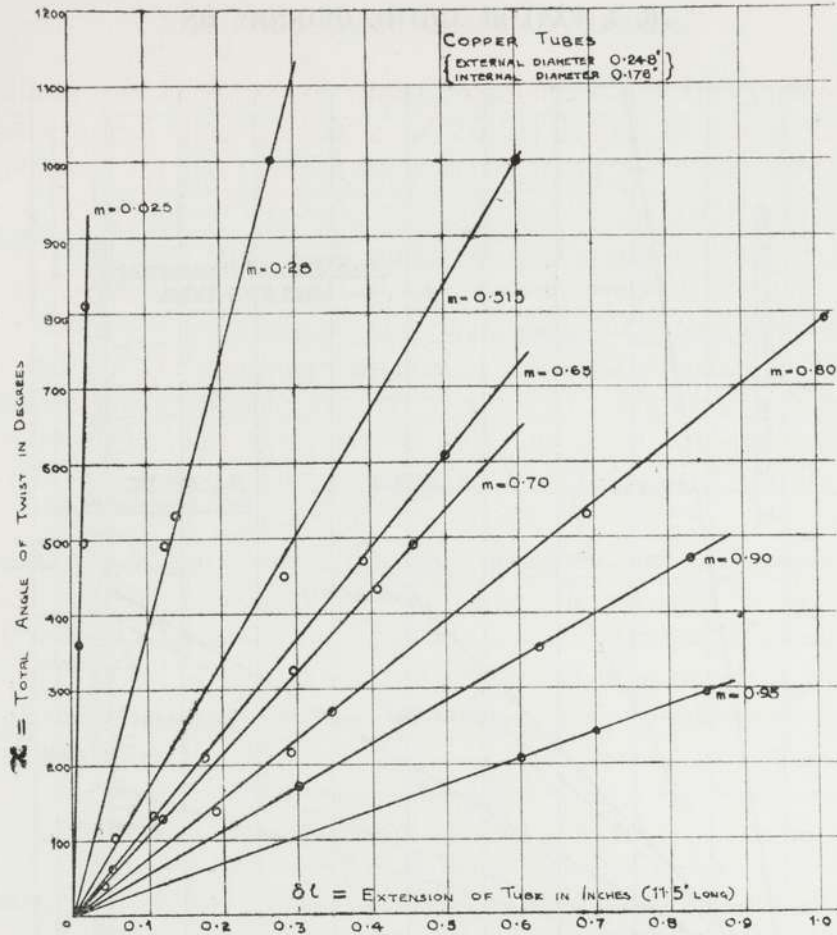

FIG. 7a.

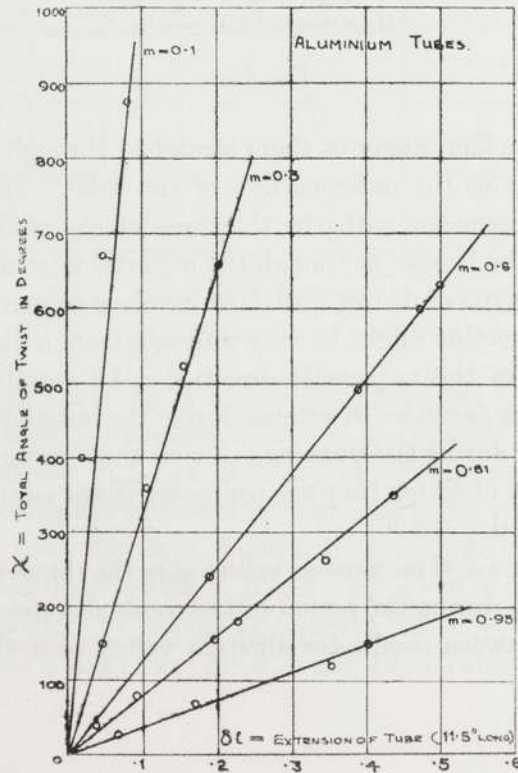

FIG. 7b.

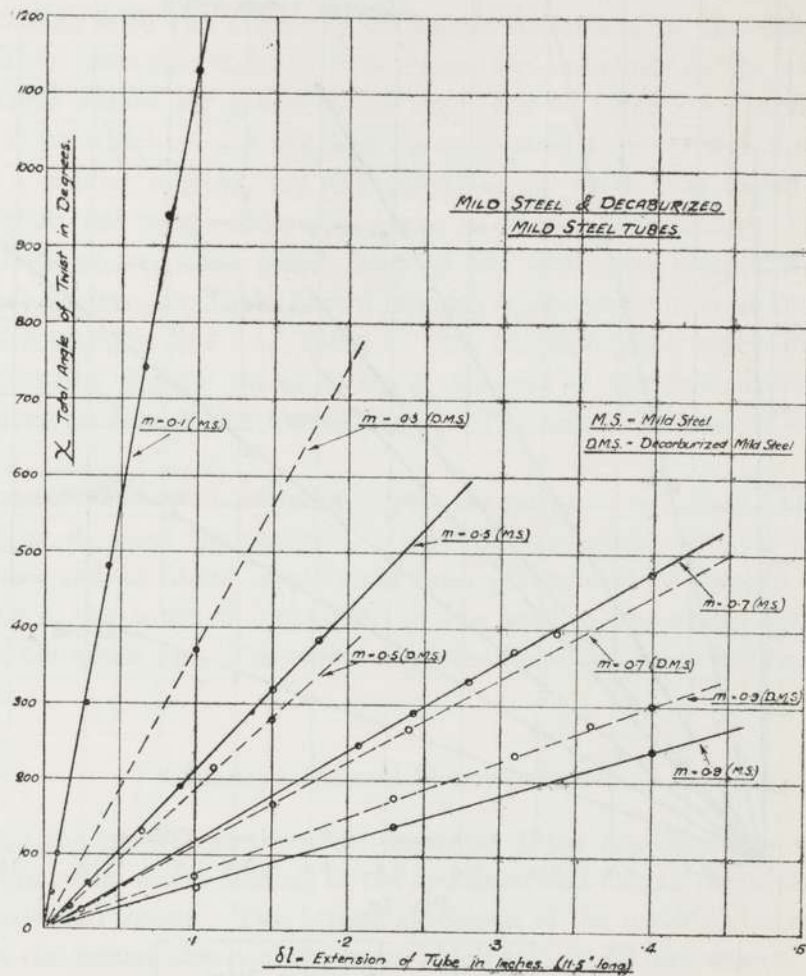

FIG. 7c.

grains were very large, in fact, many of them stretched through the whole thickness of the walls from the inner to the outer surface of the tube. The existence of crystals comparable in linear dimensions with the thickness of the wall of the tube might be expected to make the tube behave as though the material were not isotropic, for in that case the resistance to a type of distortion which involves principally contraction of the material in the radial direction might be very different from a distortion which involves principally contraction in the tangential direction. All results obtained from tubes which showed increases or decreases in volume during the initial direct extension comparable with those obtained during the combined torsion and extension were rejected on the ground that the material of which they are composed is not isotropic or that it behaves as an anisotropic material.

In determining the ratio  $d/\delta l$  for various values of  $m$  the slopes of the curves of volume change are required only during the action of the combined stress system. In order to facilitate comparison between results for different values of  $m$  the portions B C of all

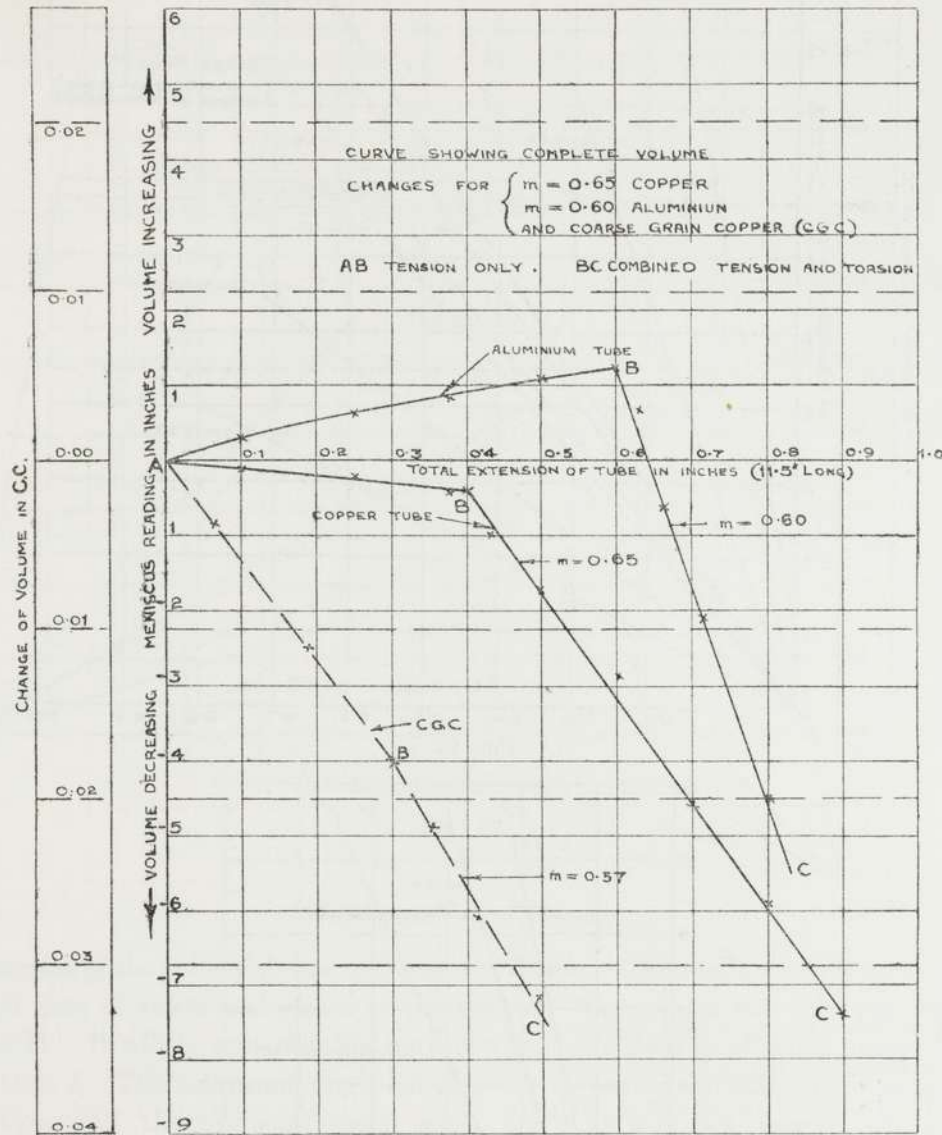

FIG. 8.

curves similar to those shown in fig. 8 are collected together in the three figures, 9, *a*, which refers to copper tubes, 9, *b* to aluminium and 9, *c* to steel. It will be seen that all these curves are, within the limits of accuracy of our measurements, straight lines. The change in internal volume is therefore proportional to the extension, and the values of the ratio  $d/\delta l$  taken from figs. 9, *a*, *b* and *c* are given in line 10 of Table I. The values of  $f/e$  obtained from formulæ 23, A, B and C are given in line 11 of Table I. The values of  $\tan 2\phi$  calculated by means of formulæ 22, A, B, C from the figures for  $\chi/\delta l$  and  $f/e$  given in lines 9 and 11 are given in line 12 of Table I.

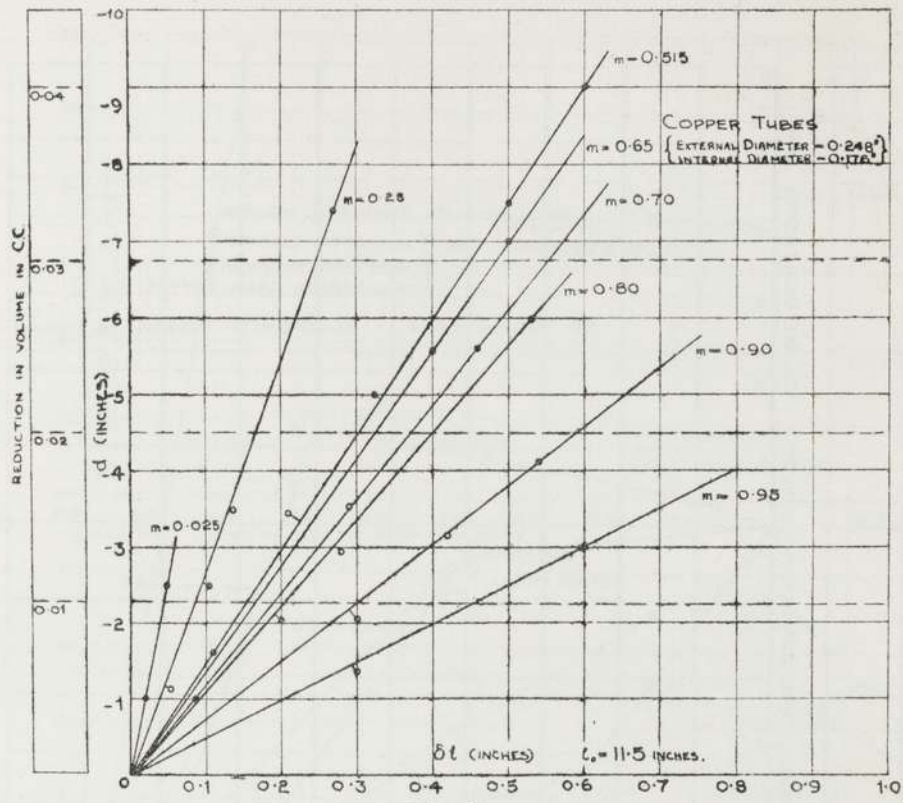

FIG. 9a.

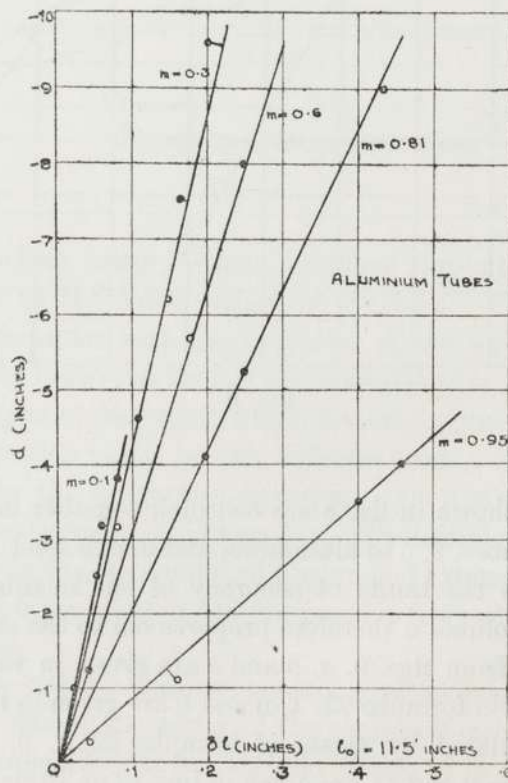

FIG. 9b.



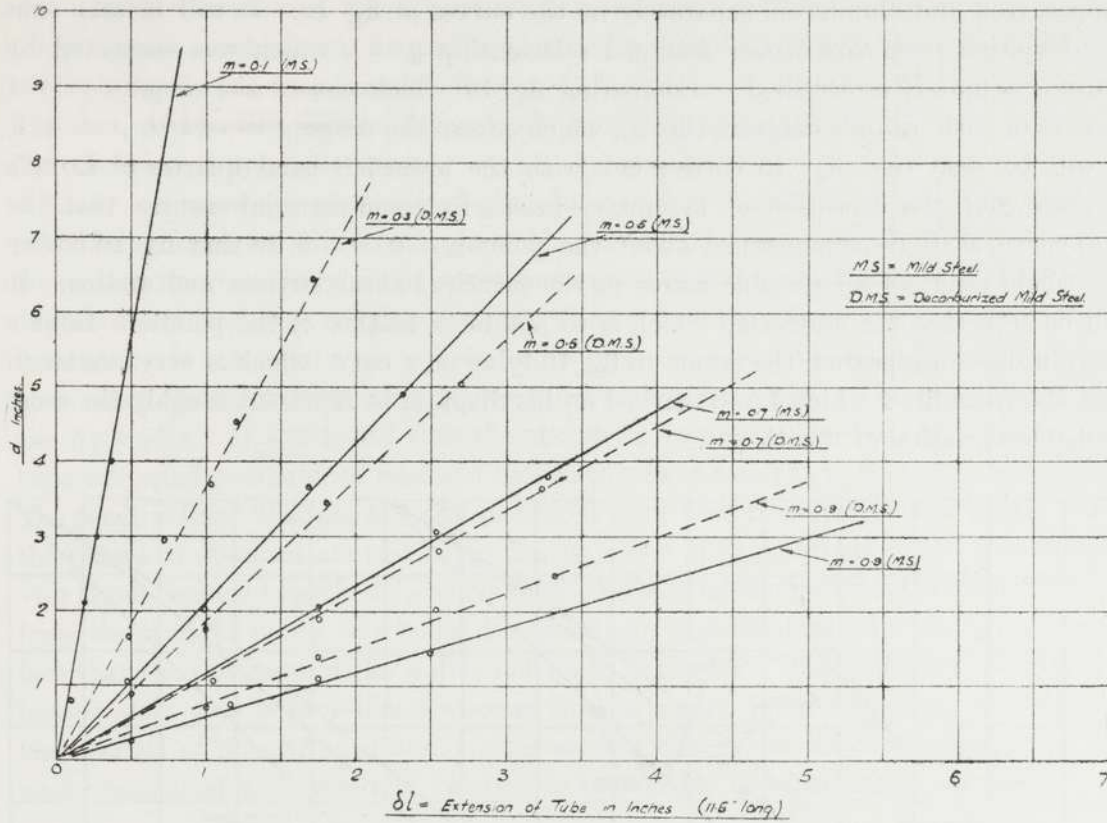

FIG. 9c.

*Interpretation of Results.*

*Orientation of the principal axes of Stress and Strain.*—The inclinations  $\theta$  and  $\phi$  of the principal axes of stress and strain respectively to the axis of the tube are collected in Table II. It will be seen that the agreement is very good in all cases except that of copper tube A. The maximum angle between the measured orientation of the principal stress axes and the principal strain axes, i.e.,  $\theta - \phi$  is 1.9 degrees, the average difference taken without regard to sign being  $0.64^\circ$ . If it is assumed that the tubes are isotropic on account of the heat treatment they have received this table, showing that  $\theta = \phi$ , may be taken as proving that the principal axes of stress and strain in an isotropic plastic material are coincident. If on the other hand this is taken as axiomatic in the definition of isotropic material then the figures in Table II may be taken as indicating that the material of the tubes is isotropic.

*Relationship between ratios of principal shear stresses and ratios of corresponding principal shear strains, i.e., between  $\mu$  and  $\nu$ .*—Taking the values of  $\theta$  and  $\phi$  from Table II and the value of  $f/e$  from Table I, the values of  $\mu = -\cos 2\theta$  and  $\nu = \frac{-1 + 2f/e}{1 + \frac{2}{3}f/e} \cos 2\phi$  shown in Table III were calculated. These are plotted for

copper, iron and aluminium separately in the curves of fig. 10. It will be seen that the deviation from VON MISES' assumed relationship  $\mu = \nu$  which was suspected by LODÉ is definitely established. Comparing fig. 10, which covers the range  $\mu = -1$  to  $\mu = 0$ , with LODÉ's diagram (fig. 2), which covers the range  $\mu = -1$  to  $\mu = +1$ , it will be seen that fig. 10 corresponds with the lower left-hand quarter of LODÉ's diagram, but the condition of symmetry in an isotropic material ensures that the  $(\mu, \nu)$  curve shall be symmetrical about the point  $\mu = 0, \nu = 0$ , so that fig. 10 covers the whole range of all possible ratios of the principal shear stresses and strains. It will be seen that the scattering which is so notable a feature of the points in LODÉ's diagram has disappeared, the points in fig. 10 lying on a curve which is very similar to that shown in fig. 2 which LODÉ marked on his diagram to represent roughly the most probable variation of  $\nu$  with  $\mu$ .

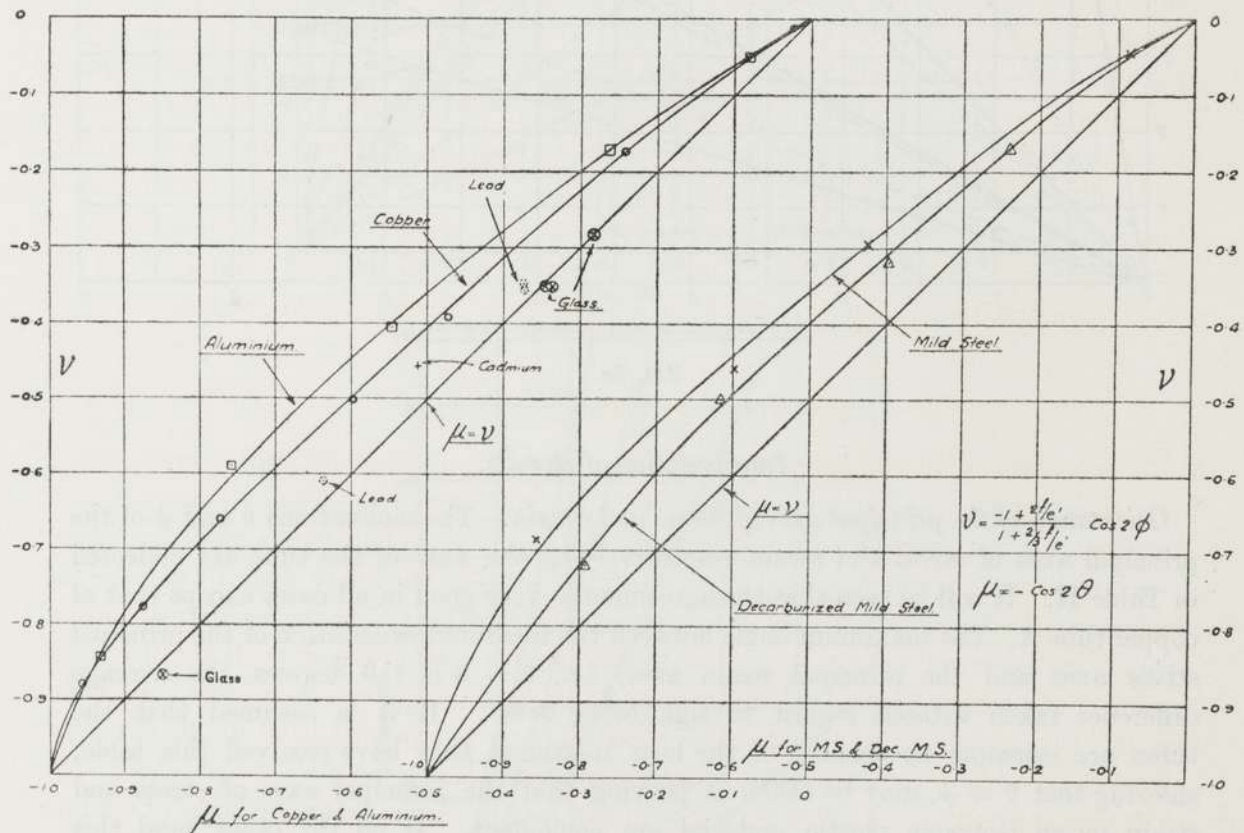

FIG. 10.

#### *Comparison with Plasticity of Glass at High Temperatures.*

It has already been pointed out that VON MISES' second assumption that  $\mu = \nu$  would be true if the equations of plastic flow were identical with those of a very viscous fluid. It is known that when glass is heated to such a temperature that it flows slowly under a direct load or a bending load, it behaves like a very viscous fluid and in fact

slow plastic distortion of this type is used in order to measure the viscosity of glass at temperatures at which it is beginning to soften. As has been mentioned in connection with plastic flow in metals, most of these tests have been carried out under conditions like that of extension under a direct load, where the type of distortion is determined by the condition of symmetry alone.

Experiments on the plasticity of glass have in fact been limited to determining the rate of distortion for different loads under varying conditions of temperature, etc. It seems that there would be no inconsistency in any existing experiments if the distortion of glass under load were not that of a very viscous fluid but were similar to that of metals for which  $\nu$  is not equal to  $\mu$ . It seemed worth while therefore to carry out tests with glass tubes similar to those already described with metal tubes. These are described in the Appendix. It was found that the change in volume of the bore of a heated glass tube subjected to combined load and extension was so small as to be hardly measurable. The small volume changes actually measured were used to calculate  $\mu$  and  $\nu$ , and the points so obtained are marked in fig. 10. It will be seen that in the case of glass, VON MISES' second hypothesis  $\mu = \nu$  is fulfilled, the small deviation of the observed points from the straight line  $\mu = \nu$  being due partly to experimental error and partly to the fact that the thickness of the wall is not quite negligible. This indicates not only that heated glass does behave like a viscous fluid in regard to its distortion, but also that the method of measuring  $\mu$  and  $\nu$  by observing changes in internal volume of a tube under combined extension and twisting is susceptible of considerable accuracy.

#### *Experiments with Lead and Cadmium.*

It was found that lead tubes and cadmium tubes change their internal volumes much less than copper, iron or aluminium tubes when subjected to combined extension and twisting. In both cases we did not find that the change from pure extension to extension combined with torsion produced a very definite bend in the curve connecting internal volume with extension. This is shown in fig. 11. The part of the curve corresponding with pure extension is from O to B. At the condition represented by B the load was reduced and torque applied. The subsequent internal volume-extension curve is shown as B C D. It will be seen that there is no very marked sudden bend in the curve at B, such as always occurred with copper, aluminium and iron.

It was at first thought that the change in volume during the extension without torsion was due to some end-effect, but a large number of different ways of fixing the ends such as casting enlarged ends, gripping the ends round a steel peg to keep the tube from collapsing inwards, and soldering on brass end pieces, all gave the same result, so that we were forced to the conclusion that the effect is a real one and that the tubes therefore behave as though they are not isotropic.

For the purpose of comparison with copper and aluminium we calculated the values of  $\mu$  and  $\nu$  from the observed slopes of the parts CD of the curves of fig. 11 and the

results are marked on fig. 10, but in view of the fact that the early parts of the curve were not horizontal we are not inclined to place much confidence in the accuracy of the

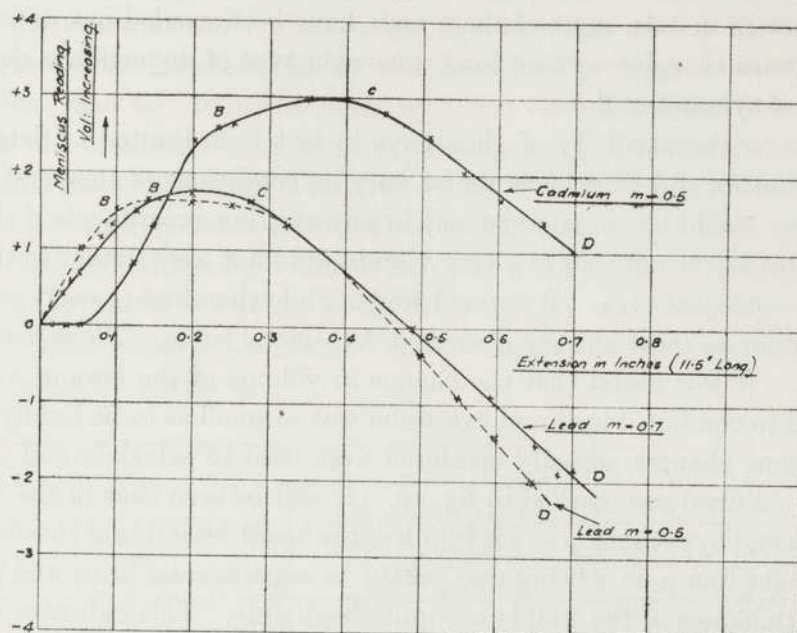

FIG. 11.

result. Subject to these remarks, however, it will be seen that lead and cadmium behave in a manner which is intermediate between that of iron and copper and that of glass.

*Comparison between VON MISES' first hypothesis for the stress at which plastic distortion begins, namely,  $\tau_1^2 + \tau_2^2 + \tau_3^2 = 2\kappa^2$  and MOHR'S hypothesis  $|\tau_1| = \kappa$ .*

The consequences of these two hypotheses in terms of the quantities measured in combined twist-extension experiments have been expressed in equations (18) and (19). It will be seen that there are two separate methods by which the two hypotheses can be compared based on (1) equations (18B) and (19B), and (2) equations (18A) and (19A).

(1) The observed values of  $S/P_0$  can be plotted against values of  $m$ . The resulting curve on either hypothesis should be an ellipse, but VON MISES' hypothesis leads to an ellipse  $S/P_0 = \left(\frac{1-m^2}{3}\right)^{\frac{1}{2}}$  which has ordinates  $2/\sqrt{3}$  times as great as the corresponding ellipse  $S/P_0 = \left(\frac{1-m^2}{4}\right)^{\frac{1}{2}}$  appropriate to MOHR'S hypothesis. The comparison between the observed values of  $S/P_0$  and the values predicted on MOHR'S and VON MISES' hypotheses are given in Table IV and are represented in the figs. 12, *a*, *b*, *c*, where the two ellipses are also marked. It will be seen that in the cases of copper and aluminium, VON MISES' hypothesis fits the observations within the limits of experimental error.

(2) A more interesting comparison can be made by means of equations (18A) and (19A).

These equations give the relationship between  $m$  and  $\theta$  according to the two hypotheses and if used directly depend on the same experimental data as those given in Table IV. On the other hand if it is assumed, as it has by all previous writers on plasticity of isotropic materials, that  $\theta = \phi$ , then equations (18A) and (19A) may be used to give the relationship between  $m$  and  $\phi$ ; thus according to MOHR'S hypothesis

$$m \sec 2\phi = m \sqrt{1 + \tan^2 2\phi} = 1$$

and according to VON MISES' hypothesis  $m \sqrt{1 + 0.75 \tan^2 2\phi} = 1$ . Now  $m$  is the ratio of the direct load applied during the combined stress to the maximum direct load during the preliminary direct stress. This is a straightforward measurement to which no ambiguity can attach.  $\phi$  is derived from the linear relationship between the observed extension and the observed twist during the application of the combined  $109d$ . The assumption that  $\theta = \phi$  therefore makes possible a comparison between VON MISES' and MOHR'S hypotheses which is quite independent of the measurements  $p$  given in line 6 of Table I, which were found by producing backwards the flat parts of the torque-extension curves in the dotted lines of figs. 6, *a*, *b* and *c*.

The comparison between  $m \sqrt{1 + \tan^2 2\phi}$  and  $m \sqrt{1 + 0.75 \tan^2 2\phi}$  with 1.00 therefore provides a method of comparing MOHR'S and VON MISES' hypotheses without the necessity for the theoretically ambiguous proceeding used to obtain  $p$  from figs. 6, *a*, *b* and *c*. This comparison is given in Table V and it will be seen that in the case of copper and aluminium it provides a striking confirmation of VON MISES' hypothesis. For copper the average value of  $m \sqrt{1 + 0.75 \tan^2 2\phi}$  is 1.006 while the average value of  $m \sqrt{1 + \tan^2 2\phi}$  is 1.082. The greatest deviation of  $m \sqrt{1 + 0.75 \tan^2 2\phi}$  from 1.00 is 2.0 per cent. and the average deviation is only 0.9 per cent. The greatest value of  $m \sqrt{1 + \tan^2 2\phi}$  is 1.138.

The case of aluminium provides confirmation of VON MISES' hypothesis which is nearly as good as that of copper, for the mean value of  $m \sqrt{1 + 0.75 \tan^2 2\phi}$  is 1.000 while the greatest deviation from 1.00 is 5 per cent. The mean value of  $m \sqrt{1 + \tan^2 2\phi}$  is 1.093, while the greatest deviation from 1.00 is 18.3 per cent.

*Mild Steel and Iron.*—For mild steel and decarburized mild steel the mean values of  $m \sqrt{1 + 0.75 \tan^2 2\phi}$  were 1.059 and 1.078 respectively, while the mean values of  $m \sqrt{1 + \tan^2 2\phi}$  were 1.144 and 1.187. Thus it appears that VON MISES' hypothesis is nearer the truth than MOHR'S.

It will be seen also that the experimental points in fig. 12*c* lie well above both the theoretical ellipses, thus indicating that the strength for combined extension and torsion is greater than that indicated in either of VON MISES' or MOHR'S theories. It seems probable, however, that this is an effect due to want of isotropy for, as is shown in fig. 12*c*, it is more marked with specimens which had been heat-treated so that the crystal grains were larger than in those which had a less coarse structure. The change in internal volume of steel tubes during the preliminary stretching indicated the same

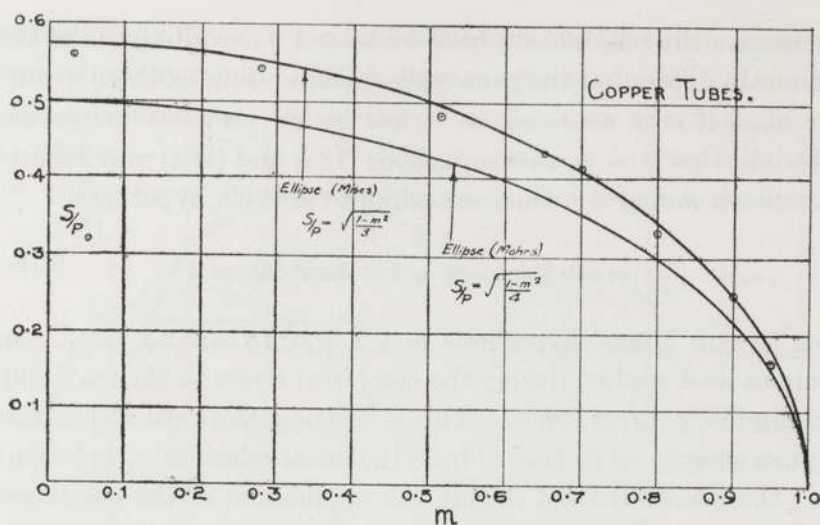

FIG. 12a.

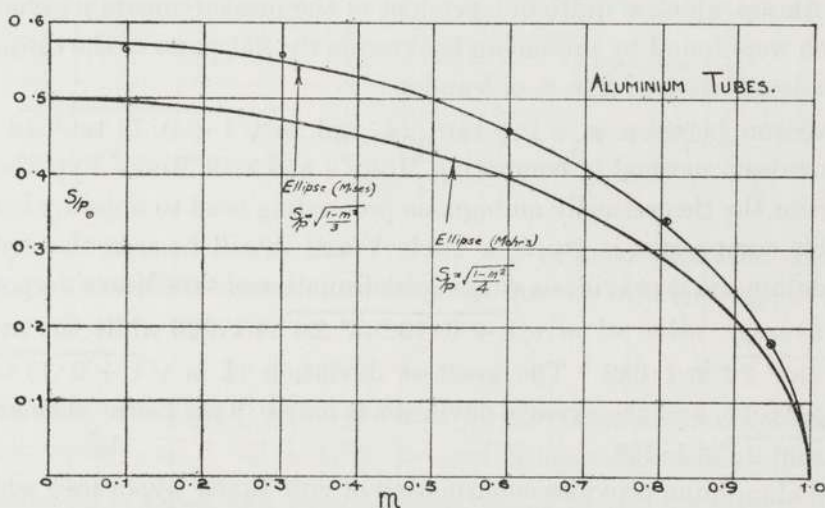

FIG. 12b.

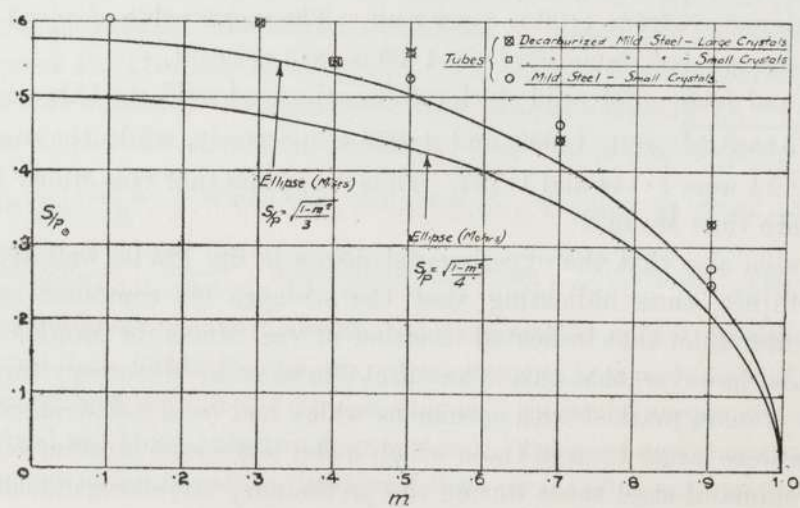

FIG. 12c.

thing. It is well known that the load-extension curve for mild steel has the peculiar property that after a certain definite extension (which depends on the heat treatment and the carbon content) it ceases rising, becomes flat or even descending with increasing extension. This flat part of the curve is succeeded by a further steady rise. This is shown for one particular specimen in the upper curve in fig. 13. The corresponding changes in internal volume of the tube in terms of the reading of the meniscus in the capillary tube of our apparatus is shown on the same diagram. It will be seen that in the elastic range which extends to about 500 lbs. load the internal volume increases. This portion is shown as O A in fig. 13. This increase in volume is well known in the

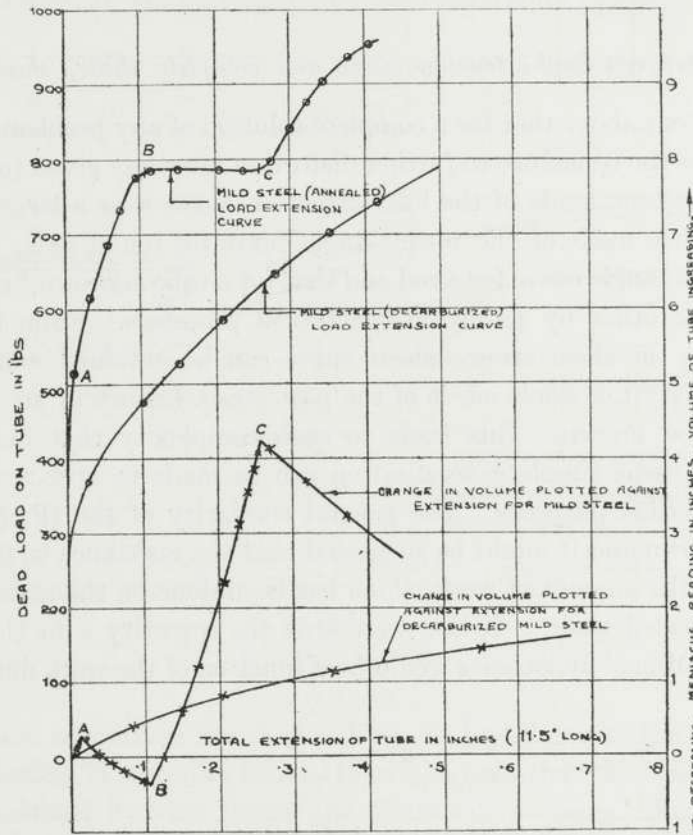

FIG. 13.

theory of elasticity. It depends on POISSON'S ratio, being zero for truly incompressible substances with POISSON'S ratio 0.5. When the material of the tube begins to yield plastically the internal volume begins to decrease till at the point B where the load has risen to 790 lbs. it begins to rise again. This change begins suddenly at the same instant that the load ceases to increase with increasing extension and during the period of constant or decreasing load the increase in internal volume is very rapid. At the point C where the extension is 0.26 inches, *i.e.*, 22 per cent., the load begins to increase and simultaneously the internal volume decreases. These changes in internal volume

are far greater than can be accounted for by the small changes in density which are known to occur when mild steel is stretched plastically. They show therefore that the material is not behaving in an isotropic manner in the tube.

In the case of decarburised mild steel the volume changes during the initial stretching of the material are usually, but not always, greater than they are in the case of fine-grained copper and aluminium. The load-extension and volume change curves for a specimen of fine-grained decarburised mild steel are shown in fig. 13. It will be seen that the removal of the carbon from the steel has removed the flat part of the load-extension curve and also the discontinuities in the curve of change in internal volume.

*Comparison between load-extension curve and complete shear, shear-stress curve.*

It was pointed out above that for a complete solution of any problem in plasticity it is necessary to know the resistance to further distortion after any given total strain. Many observations have been made of the load-extension curve over a large range of strains and some have been made of the torque-angle curve for round rods. The connection between the torque-angle curve for a rod and that for a tube is known,\* in fact one may be deduced from the other by purely mathematical processes. From the torque-angle curve for a tube, the shear stress—shear curve can be obtained, but for a complete analysis of plasticity the whole effect of the past strain history of an element of metal would have to be known. This leads to such complexity that further progress is impossible unless some simple generalisation can be made to give results of sufficient accuracy for practical purposes. The general similarity of the  $(P, e)$  and the  $(S, s)$  curves is well known and it might be suggested that the resistance to further distortion depends only on the amount of work which has been done on the material since it was in its initial annealed state. If this were true the quantity  $\kappa$  in the expression for MOHR'S and VON MISES' hypotheses would be a function of the work done; thus if

$$e = \frac{l - l_0}{l_0}$$

where  $l_0$  is the initial length in the annealed state of a specimen subjected to tensile load, and  $P$  is the stress, the total work done per unit volume is

$$Q = \int_0^e \frac{Pde}{1 + e} \quad \text{so that} \quad \frac{dQ}{d(\log e)} = P.$$

If  $s$  is the shear during a torsion test and  $S$  the shear stress,

$$Q = \int Sds \quad \text{so that} \quad S = \frac{dQ}{ds}.$$

\* See NADAI "On the Mechanics of the Plastic State in Metals," 'Trans. Amer. Soc. Mech. Eng.,' 1929.



According to Mohr's hypothesis  $S = \kappa$ , and according to von Mises' hypothesis  $2\kappa/\sqrt{3}$ , so that if  $\kappa$  to be a function of  $Q$  only, then the  $(S, s)$  and  $(P, e)$  curves would be identical, according to Mohr's theory if  $\log(1 + e) = \frac{1}{2}s$  and  $P = 2S$ , or according to von Mises' theory if  $\log(1 + e) = s/\sqrt{3}$  and  $P = S\sqrt{3}$ .

This hypothesis that  $\kappa$  is a function of  $Q$  only is compared with observation in fig. 14. The  $(S, s)$  curve was found by twisting annealed copper tubes. To find the  $(P, \log(1 + e))$  curve to be expected according to Mohr's hypothesis the observed values of  $S$  were multiplied by 2 and the observed values of  $s$  were divided by 2. For the  $(P, \log(1 + e))$  curve to be expected according to von Mises' hypothesis the observed values of  $S$  were multiplied by  $\sqrt{3}$  and for the corresponding observed values of  $s$  were divided by  $\sqrt{3}$ .

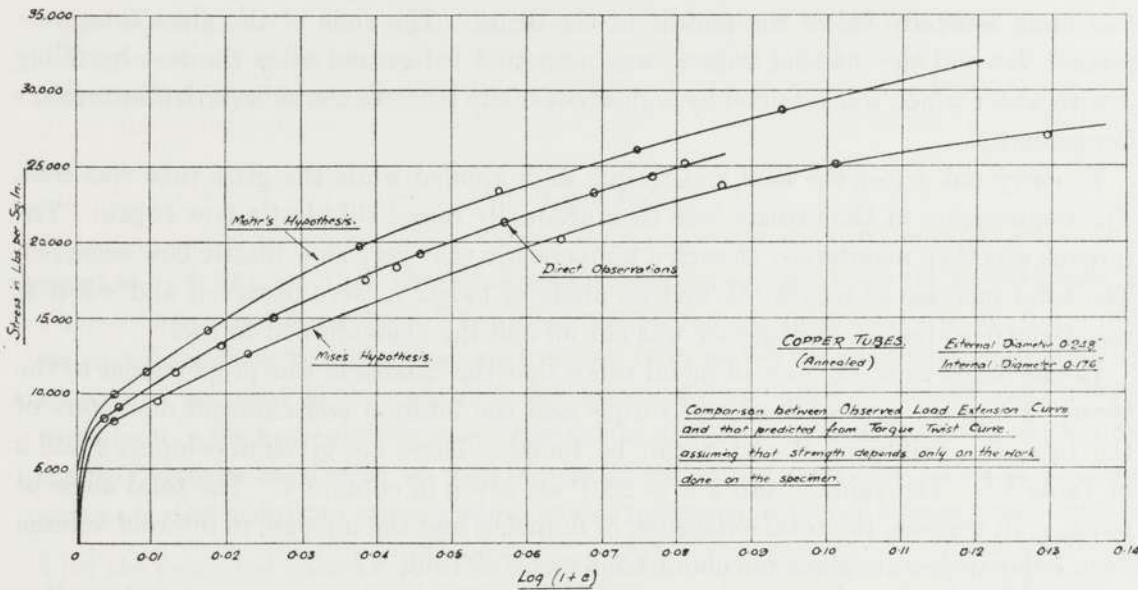

FIG. 14.

The results of these operations are shown in fig. 14 together with the values observed during a direct loading of a similar tube. It will be seen that the observed curve falls between those predicted by von Mises' and Mohr's hypotheses. For most practical purposes therefore it seems probable that it will be sufficiently accurate to assume that  $\kappa$  is a function of  $Q$  only.

Another assumption for predicting the  $(P, e)$  curve from the  $(S, s)$  curve has been made by NADAI\* who takes  $e = \frac{2}{3}s$ ,  $P = S\sqrt{3}$ , this leads in the case of copper to a rather closer agreement with the observations, but as it appears to be purely empirical there seems to be no way in which this result could be extended to the more general case of distortion where the principal stresses may have any assigned ratios.

\* Ibid.

## APPENDIX.

*Experiments with Glass Tubes.*

In order to compare the distortion of heated glass with that of metals subjected to the same type of stress distribution, glass tubes about 40 inches long 0.264 inch external and 0.192 inch internal diameter were hung vertically from one end. An electric furnace was placed round the middle portion of the tube and a thick copper tube between the furnace and the glass served to give an even temperature distribution. The lower end of the tube was gripped in a fixing at the centre of a torque drum and a direct load was hung centrally below the middle of the drum. The ends of the glass tube were ground flat and the internal volume was measured before and after the test by filling it with water which was retained by a glass cover slip stuck to the tube with Chatterton's Compound.

To carry out a test the load and torque were applied while the glass tube was cold. The temperature of the furnace was then gradually raised till plastic flow began. The furnace was then maintained at such a temperature that very slow plastic flow occurred. The total increase in length,  $\delta l$ , and an angle of twist,  $\chi$ , were observed and when  $\delta l$  was about 0.35 inches, the furnace was cut off and the glass allowed to cool.

It was found as in the case of metal tubes that the extension was proportional to the twist. From the applied load and torque and the internal and external diameters of the tube the values of  $P$  and  $S$  can be found. These are given in columns 2 and 3 of Table VI. The value of  $\tan 2\theta = 2S/P$  are given in column 4. The total angle of twist,  $\chi$ , in degrees, the total extension,  $\delta l$  in inches and the increase in internal volume  $\delta v$  in cubic inches are given in columns 5, 6 and 7 of Table VI.

To find  $f/e$  from  $\delta v$  formula (6) must be used. This formula applies to a thin-walled tube. In a tube the thickness of the walls of which are not negligible compared with the radius, the strain  $f$  varies with the radius. The value with which we are concerned is the value of  $f$  at the mean radius  $r_{m0}$  so that the "internal volume" which comes into equation (6) must be the volume enclosed by the cylinder which lies half-way between the inner and the outer wall, thus if  $l_h$  is the length of the heated portion of the tube (6) becomes

$$2f = \frac{-\delta v}{\pi r_{m0}^2 l_h},$$

and since  $e = \delta l/l_h$

$$\frac{f}{e} = -\frac{\delta v}{2\pi r_{m0}^2 \delta l} \dots \dots \dots (24)$$

It will be noticed that  $l_h$  does not enter into this formula so that it is not necessary to know how much of the tube is actually undergoing distortion. Using the observed mean value  $r_{m0} = 0.114$  inches the values of  $f/e$  found from (24) are given in column 8 of

Table VI. It will be seen that they are always very small, the greatest value, namely 0.01, is within the limits of experimental error.

To find  $\phi$ , the inclination of the principal axes of strain to the axis of the tube the values of  $\chi$ ,  $\delta l$  and  $f/e$  given in columns 5, 6 and 8, Table VI, are substituted in the

$$\tan 2\phi = \frac{2}{3}r_{m_0} \left(1 + \frac{2}{3}\frac{f}{e}\right)^{-1} \left(\frac{\chi}{\delta l}\right)$$

formula the values of  $\tan 2\phi$  so found are given in column 9, Table VI.

For comparison the values of  $2\theta$  and  $2\phi$  are given in columns 10 and 11. It will be seen that they are equal to one another, the greatest observed difference between them being only 1 degree.

*Relationship between  $\mu$  and  $\nu$ .*—Referring to formulæ (12) and (17) it will be seen that a value of  $f/e = 0.01$  makes the factor

$$\frac{-1 + 2f/e}{1 + \frac{2}{3}f/e}$$

equal to  $-0.974$ , so that the relationship between  $\mu$  and  $\nu$  would in that case be  $\nu/\mu = 0.974 (\cos 2\phi/\cos 2\theta)$ . The difference of the factor  $\cos 2\phi/\cos 2\theta$  from 1.00 owing to the fact that the measured values of  $\theta$  and  $\phi$  are not exactly equal to one another is as great as the greatest deviation of the factor  $(-1 + 2f/e)/(1 + \frac{2}{3}f/e)$  from 1.00. We have already seen that values of  $f/e$  are so small as to be within the limits of experimental error, so that the variations of the measured values of  $\mu/\nu$  from unity are due mainly to the deviation of the measured value of  $\theta$  from exact equality with the measured value of  $\phi$ . The values of  $\mu = -\cos 2\theta$  and  $\nu = \frac{-1 + 2f/e}{1 + \frac{2}{3}f/e} \cos 2\phi$  are given in columns 12 and 13 of Table VI and the results are marked in fig. 10 for comparison with the results of experiments with metal tubes.

In conclusion we wish to express our thanks to Professor INGLIS for allowing the work to be done in the Engineering Laboratory at Cambridge, to Messrs. THOMAS BOLTON & SONS for the trouble they took to produce suitable copper tubes for us, to Messrs. ACCLES & POLLOCK for presenting us with steel tubes and to the BRITISH ALUMINIUM COMPANY for aluminium tubes.

TABLE I.

## Annealed Copper Tubes.

Name of Tube.	E.	J <sub>1</sub> .	III.	C.	G.	J <sub>2</sub> .	A.	F.
Maximum load W lbs. . . . .	674	674	674	674	674	674	576	575
$m^*$ . . . . .	0.0252	0.28	0.515	0.65	0.80	0.90	0.95	0.7
$1 + e_0$ . . . . .	1.120	1.150	1.117	1.117	1.125	1.150	1.185	1.09
$P_0$ lbs./sq. in. . . . .	31,580	32,200	31,450	31,450	31,600	32,200	28,000	26,200
lbs. * $p$ . . . . .	4.65	4.52	3.98	3.62	2.70	2.0	1.00	2.9
S lbs./sq. in. = $3210(1 + e)^{\frac{2}{3}}p$ . . . . .	17,700	17,440	15,100	13,720	10,380	7,940	4,170	10,600
$\tan 2\theta = \frac{2S}{mP_0}$ . . . . .	44.5	4.02	1.87	1.344	0.820	0.557	0.314	1.160
$\chi$ degrees/ $\delta l$ inches . . . . .	37,000	3,700	1,680	1,220	782	561	350	1,068
$d$ inches/ $\delta l$ inches . . . . .	52	27.4	15.0	14.0	11.3	7.72	5.0	12.2
$f/e = 0.0037(1 + e_0)\frac{d}{\delta l}$ . . . . .	0.215	0.117	0.062	0.0578	0.047	0.033	0.0218	0.0492
$\tan 2\phi = \frac{0.00123(1 + e_0)^{-\frac{1}{2}}}{1 + \frac{2}{3}f/e} \times \frac{\chi}{\delta l}$ . . . . .	37.7	3.94	1.883	1.368	0.880	0.616	0.389	1.216

## Annealed Aluminium Tubes.

Tube reference.	VI.	III.	II.	IV.	V.
Maximum load W lbs. . . . .	305	305	305	305	305
$m$ . . . . .	0.1	0.3	0.6	0.81	0.95
$1 + e_0$ . . . . .	1.07	1.065	1.08	1.08	1.07
$P_0$ lbs./sq. in. . . . .	13,600	13,600	13,700	13,700	13,650
$p$ lbs. . . . .	2.17	2.15	1.75	1.32	0.72
S = lbs./sq. in. = $3190(1 + e_0)^{\frac{2}{3}}p$ . . . . .	7,670	7,550	6,270	4,750	2,540
$\tan 2\theta = \frac{2S}{mP_0}$ . . . . .	11.30	3.690	1.525	0.855	0.393
$\chi$ degrees/ $\delta l$ inches . . . . .	1,093	3,300	1,265	800	342.5
$d$ inches/ $\delta l$ inches . . . . .	48.8	48.0	32.0	21	8.75
$f/e = 0.00355(1 + e_0)\frac{d}{\delta l}$ . . . . .	0.1855	0.1815	0.123	0.0804	0.0332
$\tan 2\phi = \frac{0.00126(1 + e_0)^{-\frac{1}{2}}}{1 + \frac{2}{3}f/e} \times \frac{\chi}{\delta l}$ . . . . .	11.83	3.60	1.416	0.915	0.407

Table I. (continued).

Mild Steel and Decarburized Mild Steel.

Name of Tube.	Annealed Mild Steel.				Decarburized Mild Steel.			
	I.	II.	III.	IV.	V.	VI.	VII.	IX.
Maximum load W lbs. . . . .	931	942	927	952	744	741	744	744
<i>m</i> . . . . .	0.5	0.9	0.1	0.7	0.5	0.9	0.3	0.7
$1 + e_0$ . . . . .	1.035	1.038	1.035	1.04	1.04	1.04	1.04	1.04
$P_0$ lbs./sq. in. . . . .	38,500	39,100	38,400	39,600	30,900	30,800	30,900	30,900
<i>p</i> lbs. . . . .	6.30	3.30	7.30	5.70	5.4	3.25	5.8	4.4
S lbs./sq. in. = $(3112)(1 + e_0)^{\frac{2}{3}}p$	20,600	10,800	23,500	18,800	17,900	10,650	18,800	14,500
$\tan 2\theta = \frac{2S}{mP_0}$ . . . . .	2.14	0.614	12.2	1.35	2.30	0.77	4.06	1.33
$\chi$ degrees/ $\delta l$ inches . . . . .	2,100	600	11,300	1,175	1,860	750	3,700	1,125
<i>d</i> inches/ $\delta l$ inches . . . . .	24.7	18.5	45	22.5	24.7	19.2	30	19.25
$f/e = 0.00373(1 + e_0) \frac{d}{\delta l}$ . . . . .	0.0955	0.0717	0.17	0.0874	0.0956	0.074	0.117	0.0746
$\tan 2\phi = \frac{0.00122(1 + e_0)^{-\frac{1}{2}}}{1 + \frac{2}{3}f/e} \times \frac{\chi}{\delta l}$	2.37	0.686	12.0	1.325	2.10	0.85	4.10	1.285

Lead Tubes.

Cadmium Tube.

Name of Tube.	I.	II.	III.	I.
Maximum load W lbs. . . . .	52	52	52	140
<i>m</i> . . . . .	0.5	0.5	0.7	0.5
$(1 + e_0)$ . . . . .	1.01	1.01	1.02	1.015
$P_0$ lbs./sq. in. . . . .	2,650	2,650	2,650	5,880
<i>p</i> lbs. . . . .	0.431	0.430	0.268	0.75
S lbs./sq. in. = $3830(1 + e_0)^{\frac{2}{3}}p$ . . . . .	1,662	1,660	1,062	2,940
$\tan 2\theta = \frac{2S}{mP_0}$ . . . . .	2.51	2.50	1.21	1.670
$\chi$ degrees/ $\delta l$ inches . . . . .	2,000	2,000	945	1,525
<i>d</i> inches/ $\delta l$ inches . . . . .	10	10	8	7.5
$f/e = 0.000307(1 + e_0) \frac{d}{\delta l}$ . . . . .	0.0356	0.0356	0.0288	0.0270
$\tan 2\phi = \frac{0.00124(1 + e_0)^{-\frac{1}{2}}}{1 + \frac{2}{3}f/e} \times \frac{\chi}{\delta l}$	2.40	2.35	1.14	1.800

TABLE II.

Comparison of Values of  $\theta$  and  $\phi$ .

Annealed A. C. Copper Tubes.

Name of Tube.	E.	J <sub>1</sub> .	III.	C.	G.	J <sub>2</sub> .	A.	F.
2 $\theta$ (degrees) . . . . .	88.8	76.0	61.9	53.4	39.4	29.1	17.4	49.3
2 $\phi$ (degrees) . . . . .	88.5	75.8	62.0	53.8	41.4	31.6	21.3	50.6
Annealed Aluminium Tubes.								
Name of Tube.	VI.	III.	II.	IV.	V.			
2 $\theta$ . . . . .	85.0	74.8	56.7	40.6	21.5			
2 $\phi$ . . . . .	85.2	74.5	54.6	42.5	22.1			
Mild Steel and Annealed Mild Steel.								
Name of Tube.	I.	II.	III.	IV.	V.	VI.	VII.	VIII.
2 $\theta$ . . . . .	65.0	31.6	85.3	53.5	66.5	37.6	76.2	53.2
2 $\phi$ . . . . .	67.1	34.2	85.2	53.0	64.6	40.4	76.3	52.2
Lead Tube. <span style="float: right;">Cadmium Tube.</span>								
(Prepared from pure lead in suitable die.)								
Name of Tube.	I.	II.	III.	I.				
2 $\theta$ . . . . .	68° - 12'	68° - 12'	50° - 24'	59° - 6'				
2 $\phi$ . . . . .	67° - 14'	66° - 54'	48° - 42'	61° - 0'				

TABLE III.

Annealed Copper Tubes.

Reference.	E.	J <sub>1</sub> .	III.	C.	G.	J <sub>2</sub> .	A.	F.
$\mu = -\cos 2\theta \dots$	-0.021	-0.242	-0.471	-0.597	-0.773	-0.874	-0.954	-0.652
$\nu = \frac{-1 + 2f/e}{1 + \frac{2}{3}f/e} \cos 2\phi \dots$	-0.011	-0.171	-0.393	-0.502	-0.659	-0.775	-0.876	-0.554

Annealed Aluminium Tubes.

Name of Tube.	VI.	III.	II.	IV.	V.
$\mu = -\cos 2\theta \dots$	-0.087	-0.262	-0.549	-0.759	-0.930
$\nu = \frac{-1 + 2f/e}{1 + \frac{2}{3}f/e} \cos 2\phi \dots$	-0.046	-0.168	-0.405	-0.589	-0.845

Mild Steel and Decarburized Mild Steel.

Name of Tube.	I.	II.	III.	IV.	V.	VI.	VII.	VIII.
$\mu = -\cos 2\theta \dots$	-0.423	-0.852	-0.082	-0.595	-0.399	-0.792	-0.239	-0.599
$\nu = \frac{-1 + 2f/e}{1 + \frac{2}{3}f/e} \cos 2\phi \dots$	-0.296	-0.677	-0.0495	-0.470	-0.325	-0.618	-0.170	-0.498

Lead Tubes.

Cadmium Tube.

Reference.	I.	II.	III.	I.
$\mu = -\cos 2\theta \dots$	0.372	0.371	0.637	0.5135
$\nu = \frac{-1 + 2f/e}{1 + \frac{2}{3}f/e} \cos 2\phi \dots$	0.348	0.356	0.61	0.450

TABLE IV.  
Copper Tubes.

Reference.	E.	J <sub>1</sub> .	III.	C.	G.	J <sub>2</sub> .	A.	F.	
$m$ . . . . .	0.025	0.28	0.515	0.65	0.80	0.90	0.95	0.70	
$S/P_0$ . . . . .	0.560	0.541	0.480	0.436	0.329	0.247	0.149	0.405	
$\sqrt{\frac{1-m^2}{3}}$ . . . . .	0.577	0.554	0.495	0.438	0.346	0.251	0.180	0.412	
$\sqrt{\frac{1-m^2}{4}}$ . . . . .	0.500	0.480	0.428	0.380	0.300	0.218	0.155	0.357	
Aluminium Tubes.									
Reference.	VI.	III.	II.	IV.	V.				
$m$ . . . . .	0.10	0.30	0.60	0.81	0.95				
$S/P_0$ . . . . .	0.564	0.555	0.458	0.347	0.186				
$\sqrt{\frac{1-m^2}{3}}$ . . . . .	0.574	0.550	0.461	0.337	0.180				
$\sqrt{\frac{1-m^2}{4}}$ . . . . .	0.498	0.477	0.400	0.292	0.155				
Mild Steel and Decarburized Iron.									
Reference.	I.	II.	III.	IV.	V.	VI.	VII.	VIII.	IX.
$m$ . . . . .	0.5	0.9	0.1	0.7	0.5	0.9	0.3	0.7	0.4
$S/P_0$ . . . . .	0.535	0.276	0.612	0.474	0.579	0.345	0.608	0.469	0.55
$\sqrt{\frac{1-m^2}{3}}$ . . . . .	0.500	0.251	0.574	0.412	0.500	0.251	0.550	0.412	0.56
$\sqrt{\frac{1-m^2}{4}}$ . . . . .	0.433	0.218	0.498	0.357	0.433	0.218	0.477	0.357	0.56
									0.53
									0.46
Lead Tubes.					Cadmium Tube.				
Reference.	1.	2.	3.	1.					
$m$ . . . . .	0.5	0.5	0.7	0.5					
$S/P_0$ . . . . .	0.622	0.622	0.421	0.417					
$\sqrt{\frac{1-m^2}{3}}$ . . . . .	0.50	0.50	0.412	0.50					
$\sqrt{\frac{1-m^2}{4}}$ . . . . .	0.435	0.435	0.375	0.435					



TABLE V.

$m$ .	$\tan 2\phi$ .	$m \sqrt{1 + \tan^2 2\phi}$ [= 1.00 MOHR'S Hypothesis].	$m \sqrt{1 + 0.75 \tan^2 2\phi}$ [= 1.00 VON MISES' Hypothesis].	
0.28	3.94	1.138	0.995	} Copper
0.515	1.883	1.097	0.985	
0.65	1.368	1.101	1.008	
0.70	1.216	1.102	1.016	
0.80	0.880	1.060	1.005	
0.90	0.616	1.057	1.020	
0.95	0.389	1.020	1.001	
		Mean 1.082	Mean 1.006	
0.10	11.83	1.183	1.029	} Aluminium
0.30	3.60	1.121	0.983	
0.60	1.410	1.040	0.950	
0.81	0.915	1.097	1.031	
0.95	0.407	1.024	1.007	
		Mean 1.093	Mean 1.000	
0.1	12.0	1.205	1.039	} Annealed Mild Steel
0.5	2.37	1.286	1.141	
0.7	1.325	1.141	1.067	
0.9	0.686	1.090	1.046	
		Mean 1.144	Mean 1.059	
0.3	4.10	1.266	1.106	} Decarburized Mild Steel
0.5	2.10	1.163	1.038	
0.7	1.285	1.138	1.047	
0.9	0.85	1.180	1.115	
		Mean 1.187	Mean 1.078	

TABLE VI.  
Glass Tubes.

Tube No.	P lbs. sq. in.	S lbs. sq. in.	$\tan 2\theta = \frac{\chi}{2S/P}$	$\chi$ degrees.	$\delta l$ inches.	$\delta v$ cub. inches.
1 . . . . .	127	214	3.35	1035	0.418	+ 0.00006
2 . . . . .	127	179	2.80	1095	0.550	+ 0.00006
3 . . . . .	127	170	2.70	638	0.330	- 0.00030
4 . . . . .	162	51.2	0.632	137	0.296	+ 0.00024

Tube No.	$\frac{f}{e} = -\frac{\delta v}{0.0817\delta l}$	$\tan 2\phi$ .	2 $\theta$ degrees.	2 $\phi$ degrees.	$\mu$ .	$\nu$ .
1 . . . . .	- 0.0017	3.30	73.4	73.1	- 0.286	- 0.290
2 . . . . .	- 0.0013	2.65	70.4	69.4	- 0.336	- 0.353
3 . . . . .	+ 0.0111	2.57	69.7	68.8	- 0.347	- 0.351
4 . . . . .	- 0.0099	0.615	32.3	31.6	- 0.845	- 0.872

PUBLISHED AT THE OXFORD UNIVERSITY PRESS, 11, WARWICK SQUARE, LONDON, E.C.

Atlas folio. Price £3 3s.

(A reduction to Fellows of the Royal Society.)

## THE SIGNATURES IN THE FIRST JOURNAL-BOOK AND THE CHARTER-BOOK OF THE ROYAL SOCIETY.

Being a Facsimile of the Signatures of the Founders, Patrons, and Fellows of the Society from the  
year 1660 down to the year 1912.

---

Price 15s. (A reduction to Fellows of the Royal Society.)

## THE RECORD OF THE ROYAL SOCIETY.

Crown 4to. Third Edition, 1912.

Containing a full Account of the Foundation, History, &c., of the Society, with a Chronological List  
and Alphabetical Index of the Fellows from the Foundation to the year 1912.

---

Price 15s. (A reduction to Fellows of the Royal Society.)

## CATALOGUE OF THE PERIODICAL PUBLICATIONS IN THE LIBRARY OF THE ROYAL SOCIETY, 1912.

Crown 4to. 455 pages.

---

PUBLISHED AT THE CAMBRIDGE UNIVERSITY PRESS, FETTER LANE, LONDON, E.C.

## CATALOGUE OF SCIENTIFIC PAPERS FOR THE 19TH CENTURY. COMPILED BY THE ROYAL SOCIETY.

The volumes are on sale as follows:—Vols. 1-6 (1800-63), cloth (vol. 1 in half-morocco), £4 net; half-morocco, £5 5s. net. Vols. 7, 8 (1864-73), cloth, £1 11s. 6d. net; half-morocco, £2 5s. net. Single vols., cloth, £1; half-morocco, £1 8s. net. Vols. 9, 10 (1874-83), cloth, £1 5s. net; half-morocco, £1 12s. net. Vol. 11 (1874-83), cloth, £1 5s. net; half-morocco, £1 12s. net. Vol. 12 (Supplementary, 1800-83), cloth, £1 5s. net; half-morocco, £1 12s. net. Vol. 13 (1884-1900—A to Bzowski), Vol. 14 (C to Fittig), Vol. 15 (Fitting to Hyslop), cloth, £3 3s. net; Vol. 16 (I to Marbut), cloth, £5 5s. net. Vol. 17 (Marc to P), cloth, £9 net. Vol. 18 (Q to S), cloth, £9 net. Vol. 19 (T to Z), cloth, £8 8s. net.

---

## SUBJECT INDEX OF SCIENTIFIC PAPERS.

Large 8vo.

VOL. I. Pure Mathematics. 28s. cloth. 40s. half-pigskin.

VOL. II. Mechanics. 21s. cloth. 35s. half-pigskin.

VOL. III. Physics. Part I. 24s. cloth 37s. 6d. half pigskin Part II. 21s. cloth. 35s. half-pigskin,

RECENT PAPERS IN THE 'PHILOSOPHICAL TRANSACTIONS.'

*Series A.—Mathematical and Physical.*

- A 681. Problems of the Boundary State. By Sir WILLIAM HARDY, F.R.S. Pp. 38. Price 4s. 6d.
- A 682. On the Equation of State of Propellant Gases. By A. D. CROW and W. E. GRIMSHAW, Research Department, Woolwich. Pp. 34; 1 Plate. Price 5s.
- A 683. X-ray Studies of the Structure of Hair, Wool, and Related Fibres.—I. General. By W. T. ASTBURY and A. STREET, Textile Physics Research Laboratory, the University, Leeds. Pp. 27; 2 Plates. Price 5s.
- A 684. The Yield Point and Initial Stages of Plastic Strain in Mild Steel Subjected to Uniform and Non-Uniform Stress Distributions. By GILBERT COOK, D.Sc., M.Inst.C.E., M.I.Mech.E., Professor of Mechanical Engineering, King's College, London. Pp. 44. Price 5s. 6d.
- A 685. The Colorimetric Properties of the Spectrum. By J. GUILD, A.R.C.S., F.Inst.P., F.R.A.S., National Physical Laboratory. Pp. 39. Price 5s.
- A 686. The Ternary System Carbon Monoxide-Nitrogen-Hydrogen and the Component Binary Systems between Temperatures of  $-185^{\circ}$  and  $-215^{\circ}$  C., and between Pressures of 0 and 225 Atm. By T. T. H. VERSCHOYLE. Pp. 32. Price 4s.
- A 687. A Research on Faraday's "Steel and Alloys." By SIR ROBERT HADFIELD, Bt., F.R.S. Pp. 72; 9 Plates. Price 14s. 6d.
- A 688. Determination of the Yard in Wave-lengths of Light. By A. E. H. TUTTON, M.A., D.Sc., F.R.S. Pp. 30. Price 4s.

*Series B.—Biological.*

- B 464. Some Fossil Plants of Early Devonian Type from the Walhalla Series, Victoria, Australia. By WILLIAM H. LANG, F.R.S., Barker Professor of Cryptogamic Botany in the University of Manchester, and ISABEL C. COOKSON, B.Sc., Lecturer in Botany in the University of Melbourne and Honorary Research Fellow in the University of Manchester. Pp. 30; 3 Plates. Price 6s.
- B 465. On the Development of the Vertebral Column of Anura. By HIMADRI KUMAR MOOKERJEE, D.Sc. (Lond.), D.I.C., Lecturer in Zoology, Sir Rash Behari Ghose Travelling Fellow, Calcutta University, Marshall Scholar, Imperial College of Science and Technology, London. Pp. 32; 5 Plates. Price 9s.
- B 466. The Reproductive Cycle of the Three-Spined Stickleback, *Gasterosteus Aculeatus*, Linn. By A. CRAIG-BENNETT, M.A., Department of Zoology, University of Edinburgh. Pp. 83; 4 Plates. Price 14s.
- B 467. Studies in the Biochemistry of Micro-Organisms. By H. RAISTRICK and Others. Pp. 367. Price £2 10s.  
Volume 220 (1931), 367 pp. Cloth, £2 15s.
- B 468. Studies in Tunicate Development. Part II.—Abbreviation of Development in the Molgulidæ. By N. J. BERRILL, Department of Zoology, McGill University, Montreal. Pp. 66. Price 8s. 6d.
- B 469. Contributions to the Knowledge of Lower Carboniferous Plants. Part III. By JOHN WALTON, M.A., D.Sc., Regius Professor of Botany at the University of Glasgow. Pp. 33; 4 Plates. Price 7s.
- B 470. The Passage of Sperms and of Eggs through the Oviducts in Terrestrial Vertebrates. By G. H. PARKER, Zoological Laboratory, Harvard University. Pp. 39. Price 5s.

Cloth cases for binding the volumes of the 'Philosophical Transactions.' Price 3s. 6d.

PUBLISHED FOR THE ROYAL SOCIETY BY  
HARRISON AND SONS, LTD., 44-47, ST. MARTIN'S LANE, LONDON, W.C.2.