

City University of New York (CUNY)

CUNY Academic Works

Dissertations, Theses, and Capstone Projects

CUNY Graduate Center

2-2017

The Proscriptive Principle and Logics of Analytic Implication

Thomas M. Ferguson

The Graduate Center, City University of New York

[How does access to this work benefit you? Let us know!](#)

More information about this work at: https://academicworks.cuny.edu/gc_etds/1882

Discover additional works at: <https://academicworks.cuny.edu>

This work is made publicly available by the City University of New York (CUNY).

Contact: AcademicWorks@cuny.edu

THE PROSCRIPTIVE PRINCIPLE AND LOGICS OF ANALYTIC IMPLICATION

by

THOMAS MACAULAY FERGUSON

A dissertation submitted to the Graduate Faculty in Philosophy in partial fulfillment of the requirements for the degree of Doctor of Philosophy, The City University of New York

2017

© 2017

THOMAS MACAULAY FERGUSON

All Rights Reserved

This manuscript has been read and accepted by the Graduate Faculty in Philosophy in satisfaction of the dissertation requirement for the degree of Doctor of Philosophy.

Professor Sergei Artemov

Date

Chair of Examining Committee

Professor Iakovos Vasiliou

Date

Executive Officer

Professor Graham Priest

Professor Heinrich Wansing

Professor Kit Fine

Supervisory Committee

Abstract

THE PROSCRIPTIVE PRINCIPLE AND LOGICS OF ANALYTIC IMPLICATION

by

THOMAS MACAULAY FERGUSON

Adviser: Professor Graham Priest

The analogy between inference and mereological containment goes at least back to Aristotle, whose discussion in the *Prior Analytics* motivates the validity of the syllogism by way of talk of parts and wholes. On this picture, the application of syllogistic is merely the *analysis* of concepts, a term that presupposes—through the root ἀνά + λύω—a mereological background.

In the 1930s, such considerations led William T. Parry to attempt to codify this notion of logical containment in his system of analytic implication AI. Parry’s system AI was later expanded to the system PAI. The hallmark of Parry’s systems—and of what may be thought of as *containment logics* or *Parry systems* in general—is a strong relevance property called the ‘Proscriptive Principle’ (**PP**) described by Parry as the thesis that:

No formula with analytic implication as main relation holds universally if it has a free variable occurring in the consequent but not the antecedent.

This type of proscription is on its face justified, as the presence of a novel parameter in the consequent corresponds to the introduction of new *subject matter*. The plausibility of the thesis that the content of a statement is related to its subject matter thus appears also to support the validity of the formal principle.

Primarily due to the perception that Parry’s formal systems were intended to accurately model Kant’s notion of an *analytic judgment*, Parry’s deductive systems—and the suitability

of the Proscriptive Principle in general—were met with severe criticism. While Anderson and Belnap argued that Parry’s criterion failed to account for a number of *prima facie* analytic judgments, others—such as Sylvan and Brady—argued that the utility of the criterion was impeded by its reliance on a ‘syntactical’ device.

But these arguments are restricted to Parry’s work *qua* exegesis of Kant and fail to take into account the breadth of applications in which the Proscriptive Principle emerges. It is the goal of the present work to explore themes related to deductive systems satisfying one form of the Proscriptive Principle or other, with a special emphasis placed on the rehabilitation of their study to some degree. The structure of the dissertation is as follows:

* In Chapter 2 we identify and develop the relationship between Parry-type deductive systems and the field of ‘logics of nonsense.’ Of particular importance is Dmitri Bochvar’s ‘internal’ nonsense logic Σ_0 , and we observe that two \vdash -Parry subsystems of Σ_0 —Harry Deutsch’s S_{fde} and Frederick Johnson’s RC—can be considered to be the products of particular ‘strategies’ of eliminating problematic inferences from Bochvar’s system.

* The material of Chapter 3 considers Kit Fine’s program of state space semantics in the context of Parry logics. Fine—who had already provided the first intuitive semantics for Parry’s PAI—has offered a formal model of truthmaking (and falsmaking) that provides one of the first natural semantics for Richard B. Angell’s logic of *analytic containment* AC, itself a \vdash -Parry system. After discussing the relationship between state space semantics and nonsense, we observe that Fabrice Correia’s weaker framework—introduced as a semantics for a containment logic weaker than AC—tacitly endorses an implausible feature of allowing *hypernonsensical* statements. By modelling Correia’s containment logic within the stronger setting of Fine’s semantics, we are able to retain Correia’s intuitions about factual equivalence without such a commitment. As a further application, we observe that Fine’s setting can resolve some ambiguities in Greg Restall’s own truthmaker semantics.

* Chapter 4 we consider interpretations of disjunction that accord with the characteristic failure of **Addition** in which the evaluation of a disjunction $A \dot{\vee} B$ requires not only the truth of one disjunct, but also that *both* disjuncts satisfy some further property. In the setting of computation, such an analysis requires the existence of some procedure tasked with ensuring the satisfaction of this property by both disjuncts. This observation leads to a computational analysis of the relationship between Parry logics and logics of nonsense in which the semantic category of ‘nonsense’ is associated with catastrophic faults in computer programs. In this spirit, we examine semantics for several \vdash -Parry logics in terms of the successful execution of certain types of programs and the consequences of extending this analysis to dynamic logic and constructive logic.

* Chapter 5 considers these faults in the particular case in which Nuel Belnap’s ‘artificial reasoner’ is unable to retrieve the value assigned to a variable. This leads not only to a natural interpretation of Graham Priest’s semantics for the \vdash -Parry system S_{fde}^* but also a novel, many-valued semantics for Angell’s AC, completeness of which is proven by establishing a correspondence with Correia’s semantics for AC. These many-valued semantics have the additional benefit of allowing us to apply the material in Chapter 2 to the case of AC to define intensional extensions of AC in the spirit of Parry’s PAI.

* One particular instance of the type of disjunction central to Chapter 4 is Melvin Fitting’s *cut-down disjunction*. Chapter 6 examines cut-down operations in more detail and provides bilattice and trilattice semantics for the \vdash -Parry systems S_{fde} and AC in the style of Ofer Arieli and Arnon Avron’s logical bilattices. The elegant connection between these systems and logical multilattices supports the fundamentality and naturalness of these logics and, additionally, allows us to extend epistemic interpretation of bilattices in the tradition of artificial intelligence to these systems.

* Finally, the correspondence between the present many-valued semantics for AC and those

of Correia is revisited in Chapter 7. The technique that plays an essential role in Chapter 4 is used to characterize a wide class of first-degree calculi intermediate between **AC** and classical logic in Correia's setting. This correspondence allows the correction of an incorrect characterization of classical logic made by Correia and leads to the question of how to characterize hybrid systems extending Angell's **AC***. Finally, we consider whether this correspondence aids in providing an interpretation to Correia's first semantics for **AC**.

Personal Acknowledgments

The dissertation that follows would not have existed were it not for the support of a legion of friends, family, and colleagues.

Above all, I am grateful for the patience and persistence of my wife Virginia and our children Mirabel and Rowan. They bore the trials that accompany the writing of a dissertation—the inevitable sleepless nights, long absences, and too-frequently empty bank accounts—alongside me year after year. Their encouragement has remained resolute even during the most difficult times and I would have long ago surrendered to my anxieties had it not been for their optimism and loyalty.

I also acknowledge the essential contributions made to me by many other family members. Much of the work in this dissertation—and outside it—benefited from the constructive and detailed criticism of my father, Gillum Ferguson, who diligently read drafts of my work. As I wrote the dissertation, my grandfather Richard Ferguson and grandmother Marjorie Munn were sources of inspiration and it is my hope that I have made them proud. The support of my mother, Marsha Smith, and her husband Bill has also been critical, as has been the support of my stepmother Susan Ferguson and my parents-in-law Richard and Carol Kropp. Whether lending us their roofs between moves or taking care of the children while I attended conferences, any successes I may have achieved were built on the foundation of their collective support.

Being able to study logic in New York—home to so many outstanding logicians—has

been a remarkable privilege and I owe a significant debt to every member of the New York logic community. In particular, I cannot overstate the importance of the opportunity to learn from and interact with the members of my committee—Professors Graham Priest, Heinrich Wansing, and Kit Fine—whose encouragement, advice, and confidence has been indispensable during the past few years. Furthermore, I remain grateful to Professors Sergei Artemov and Melvin Fitting for agreeing to serve as examiners during my defense and for the thoughtful remarks they shared with me. Beyond the input of the foregoing individuals, the contents of the dissertation have been sharpened and refined by the many pages of comments and criticism I have received from anonymous referees; that they are anonymous does not lessen my gratitude for their help.

Finally, I would like to thank Professor Jon Jarrett, who first showed me how rewarding philosophy can be.

Permissions

The present dissertation incorporates material that has previously appeared in print and I am grateful to Springer, Oxford University Press, Taylor & Francis, and the IEEE for permission to include this material. Much of the text of Chapter 2 is drawn from the paper:

Ferguson, T. M. (2015b). Logics of nonsense and Parry systems. *Journal of Philosophical Logic*, 44(1):65–80.

and can be found at <http://dx.doi.org/10.1007/s10992-014-9321-y>. This material is reprinted courtesy of Springer with license 4026261345546.

Much of Chapter 4 is a revised version of the paper:

Ferguson, T. M. (2014a). A computational interpretation of conceptivism. *Journal of Applied Non-Classical Logics*, 24(4):333–367.

This is retrievable at <http://dx.doi.org/10.1080/11663081.2014.980116>. Relevant material in this chapter is reprinted courtesy of Taylor & Francis.

Much of Chapter 5 has appeared as the paper:

Ferguson, T. M. (2016b). Faulty Belnap computers and subsystems of FDE. *Journal of Logic and Computation*, 26(5):1617–1636.

The final publication is available at <http://dx.doi.org/10.1093/logcom/exu048> and is reprinted by arrangement with Oxford University Press and license 4027741434818.

Chapter 6 amalgamates material that has appeared in two papers, the conference paper which is reprinted, with permission:

Ferguson, T. M. (2015a). Cut-down operations on bilattices. In *Proc. 45th International Symposium on Multiple-Valued Logic (ISMVL 2015)*, pages 24–29, Los Alamitos, CA. IEEE Computer Society.

and the journal publication that expands on its themes:

Ferguson, T. M. (2016c). Rivals to Belnap-Dunn logic on interlaced trilattices. *Studia Logica*, pages 1–26. To appear.

The former can be found at <http://dx.doi.org/10.1109/ISMVL.2015.14> and appears courtesy of the IEEE Computer Society Press with the following qualification:

In reference to IEEE copyrighted material which is used with permission in this thesis, the IEEE does not endorse any of the City University of New York's products or services. Internal or personal use of this material is permitted. If interested in reprinting/republishing IEEE copyrighted material for advertising or promotional purposes or for creating new collective works for resale or redistribution, please go to http://www.ieee.org/publications_standards/publications/rights/rights_link.html to learn how to obtain a License through RightsLink.

The final version of the latter is at <http://dx.doi.org/10.1007/s11225-016-9695-7> and reprinted by permission of Springer with license 4026261219706.

Chapter 7 incorporates material that has appeared in:

Ferguson, T. M. (2016a). Correia semantics revisited. *Studia Logica*, 104(1):145–173.

The final publication is available at <http://dx.doi.org/10.1007/s11225-015-9631-2> and is reprinted courtesy of Springer with license 4026261456268.

Contents

Contents	xiii
List of Figures	xviii
1 Introduction: The Proscriptive Principle	1
1.1 The Proscriptive Principle and Its Rivals	1
1.1.1 Parry’s Proscriptive Principle	5
1.1.2 Proscription as ‘Conceptivism’	13
1.2 Overview of the Material	19
2 Nonsense and Proscription	22
2.1 Introduction and Semantical Preliminaries	23
2.2 Nonsense Logics	23
2.2.1 Semantic Paradoxes	25
2.2.2 Positivism and Verifiability	27
2.2.3 Category Mistakes	29
2.2.4 Many-Valued Semantics for Two Nonsense Logics	31
2.3 Two Strategies for Containment	35
2.3.1 Containment Through Connexivity: Johnson’s RC	35
2.3.2 Containment Through Paraconsistency: The System S_{fde}	41

2.4	The Role of S_{fde} in Paraconsistent Parry Systems	45
2.5	Conclusions	51
3	Metaphysical Considerations on State Space Semantics	53
3.1	State Space Semantics	54
3.1.1	Facts and Their ‘Philosophical Entourage’	54
3.1.2	Fine’s Truthmaker Semantics	58
3.1.3	Validity and Consequence: Two Systems	65
3.2	Correia on Factual Equivalence	70
3.2.1	Correia’s Logic of Factual Equivalence	70
3.2.2	Correia’s Rejection of Distribution	72
3.2.3	Hypernonsensicality	74
3.2.4	Factual Equivalence Without Hypernonsense	77
3.3	Restall on Truthmaking	79
3.3.1	Restall’s Truthmaker Semantics	80
3.3.2	Worlds, Again	83
3.3.3	The Emergence of RM_{fde}	88
3.4	Concluding Remarks	95
4	A Computational Interpretation of Conceptivism	97
4.1	Formal Remarks	97
4.1.1	A Family of \rightarrow -Parry Deductive Systems	98
4.1.2	A Family of \vdash -Parry Deductive Systems	101
4.2	The Failure of Addition	105
4.2.1	Meaninglessness	105
4.2.2	Intensional Disjunction	107
4.2.3	Free Choice Disjunction	110

4.2.4	Cut Down Disjunction	112
4.3	Towards a Computational Interpretation	114
4.3.1	Ill-Formedness	117
4.3.2	Declaration of Variables	120
4.3.3	Three Concrete Cases	122
4.4	Enriching the Interpretation	127
4.4.1	Conceptivism and Propositional Dynamic Logic	128
4.4.2	An Intuitionistic Conceptivist Logic	132
4.5	Conclusions	139
5	Faulty Belnap Computers and Subsystems of E_{fde}	142
5.1	Introduction	143
5.2	Three First-Degree Logics	144
5.2.1	First-Degree Entailment E_{fde}	144
5.2.2	Single Address Faulty E_{fde}	147
5.2.3	Two Address Faulty E_{fde}	149
5.3	Angell's Analytic Containment AC	153
5.3.1	Correia Semantics for Analytic Containment	154
5.3.2	Equivalence of NC and AC	157
5.4	Steps Forward	166
5.4.1	The Gödel-Fine Analysis of AC	166
5.4.2	Extending to Higher Degree Formulae	168
5.5	Conclusion	175
6	Cut-Down Operations on Multilattices	177
6.1	Introduction: Bilattices and Cut-Downs	178
6.2	Cut-Down Operations on Bilattices	181

6.2.1	Logical Bilattices	181
6.2.2	S_{fde} on Bilattices	183
6.3	$\mathcal{NLN}\mathcal{E}_2$ and AC	189
6.4	Cut-Down Operations on Trilattices	194
6.4.1	Generalizations of Cut-Down Operations	197
6.4.2	Some Properties of Trifilters	200
6.5	Analytic Logic on Trilattices	202
6.5.1	S_{fde} on Trilattices	203
6.5.2	Interlude: Analytic Containment and S_{fde}	207
6.5.3	AC on Trilattices	210
6.6	Future Directions	215
7	Correia Semantics Revisited	217
7.1	Introduction	217
7.2	Analytic Containment and Correia Semantics	218
7.2.1	Semantical Preliminaries	219
7.2.2	Correlating the Two Semantics	220
7.2.3	A General Characterization Lemma	221
7.3	Correia Models and Other Propositional Logics	222
7.3.1	First-Degree Entailment	223
7.3.2	‘Analytic’ Extensions	225
7.3.3	Non-‘Analytic’ Extensions	228
7.3.4	Correia’s Characterization of Classical Logic	233
7.4	Conclusions and Future Research	237
7.4.1	Extensions of AC^*	238
7.4.2	Clauses and Clutters	242

<i>CONTENTS</i>	xvii
8 Concluding Remarks	245
8.1 Refining the Notion of Content	246
8.1.1 The Content of Entailments	246
8.1.2 Quantification	249
8.2 Related Deductive Calculi	251
8.2.1 Dual Systems	251
8.2.2 Other Parry Systems	253
8.3 Conclusion	257
Bibliography	258

List of Figures

3.1	$T \sqsupseteq U$ and $U' \sqsubseteq T'$	61
4.1	Relationships Between \rightarrow -Parry Systems	100
4.2	Relationships Between \vdash -Parry Systems	105
4.3	McCarthy-style Algorithm Interpreting Disjunction	118
4.4	Algorithm with Undeclared Variables	121
5.1	Systems Intermediate Between PAC and DAI	175
6.1	The Bilattice \mathcal{FOUR}_2	184
6.2	The Bilattice \mathcal{NLNE}_2	190
7.1	First-Degree Systems Intermediate Between AC and CL	234
8.1	Deductive Systems in the Neighborhood of PAI	254

Chapter 1

Introduction: The Proscriptive Principle

1.1 The Proscriptive Principle and Its Rivals

The analogy between inference and mereological containment goes at least back to Aristotle, whose discussion in the *Prior Analytics* motivates the validity of the syllogism by way of talk of parts and wholes.

When three terms are so related to one another that the last is wholly contained in the middle and the middle is wholly contained in or excluded from the first, the extremes must admit of perfect syllogism. By ‘middle term’ I mean that which both is contained in another and contains another in itself... and by ‘extremes’ (a) that which is contained in another and (b) that in which another is contained. (15, p. 209)

On this picture, the application of syllogistic is merely the *analysis* of concepts, a term that presupposes—through the root ἀνά + λύω—a mereological background.

Considering the backdrop of class logic that figures so heavily in extensional syllogistic, such an analogy is perhaps inevitable. But the more general mereological analogy that logical inference *in general* is a process that breaks up a statement into its constituent parts finds expression in many discussions of inferences between propositions. For example, as reported by William and Martha Kneale, one of the four competing interpretations of the conditional described by Sextus Empiricus is a relation of containment:

And those who judge by implication say that a true conditional is one whose consequent is contained potentially in its antecedent.(123, p. 129)

One of the most explicit articulations of this analogy is found in Immanuel Kant's characterization of an 'analytic' judgment. Certainly—as will be reflected in the sequel—Kant's name is uniformly the first to be invoked when this subject is taken up. Kant, recall, determines that a judgment 'A is B' is analytic precisely in those cases in which:

the predicate *B* belongs to the subject *A* as something that is (covertly) contained in this concept *A*.(118, p. 130)

In more dynamic—and colorful—terms, Kant goes on to characterize the analyticity of a judgment in terms of an activity, or an operation carried out on concepts:

One could also call [analytic judgments] judgments of clarification... since through the predicate the former do not add anything to the concept of the subject, but only break it up by means of analysis into its component concepts, which were already thought in it (though confusedly).(118, p. 130)

In its identification of a particular species of inference with the containment of concepts, Kant's criterion is essentially the assertion that there exists a correspondence between the behavior of logical inference and background assumptions concerning not only an underlying class theory but also a mereology of concepts or meanings.

To investigate this analogy with further rigor, of course, demands that the nature of relata of this containment relation—concepts, semantic content, meanings—be made more precise. Considering the sheer diversity of competing interpretations of Kant’s project, it is hardly surprising that analyses of this relationship between inference and content are just as diverse.

The relationship between inference and the content or meaning of a sentence was taken up frequently during the early development of modern analytic philosophy. As Ken Gemes identifies in (93), Rudolph Carnap considers the class of logical consequences of a sentence A (modulo classical logic) to be the essential ingredient in determining its content. He writes:

the class of non-valid consequences of a given sentence is called the *content* of this sentence.(40, p. 42)

In other words, the content of a sentence A is given by the the statements that follow from it in a non-vacuous manner.

Like Carnap, Karl Popper’s characterization of a statement’s content—also related by Gemes in (93)—places an emphasis on the role of classical inference and is similar in its character.

By logical content (or the consequence class of $[A]$) we mean the class of all statements that follow from $[A]$.(153, p. 385)

Although both recognize a relationship between some notion of *content* and logical inference, the nature of Carnap and Popper’s analyses diverge from Kant in an important way. Because Kant characterizes analyticity of an inference in terms of the structure and relationships between the concepts involved, the semantic notion is clearly taken as the primitive notion. In contrast, both Carnap and Popper’s analyses (considered by Gemes in (93) to be the ‘traditional’ notion) treat content as a class of statements whose extension is determined— at least, in part—by the more fundamental notion of classical logic.

After Gemes himself outlined a novel theory of content in (93) and (94), Gemes argued that the earlier theories of Carnap and Popper were too generous with respect to their respective notions of content for their endorsement of the following property:

where content is identified with consequence class, for any A and B , as long as $\neg A$ does not entail B , there will always be a content part of A that ‘includes’ B , namely, [the content of] $A \dot{\vee} B$.(93, p. 600)

Gemes cites as an unfortunate consequence of this ‘traditional view’ that

not only do Relativity theory and Newtonian mechanics share common content but also so do Relativity theory and your favorite crackpot theory, say, Dianetics.(93, p. 597)

Gemes outlines a number of further pathologies that result from this type of definition. For example, on both Carnap and Popper’s accounts any satisfiable statement A contains both $A \dot{\vee} B$ and $A \dot{\vee} \neg B$ for an arbitrary B and—since B is either true or false—will thereby contain a true statement as part of its content. Hence, if the ‘partial truth’ of a statement is understood as the property that some content part of that statement is true, then *every* contingently false statement is partially true, contrary to our natural expectations.

While not motivated as analyses of meaning containment *per se*, each of these theories of content is rich enough to indirectly support a corresponding characterization of inferences that are analytic in a Kantian sense, that is, those inferences valid in virtue of the consequent’s content being *part of* the antecedent’s content. Although somewhat circular, Popper’s account entails that classical consequence *is* a logic of meaning containment.

Ross Brady more directly attacks the problem in his description of weak relevant logics that can be thought of as logics of containment of meaning. Brady’s ‘containment logic’ DJ—described in (36)—builds off of considerations articulated in his (35) and, most recently, has borne fruit in his analysis of relevant arithmetic in (37).

Brady's work argues that meaning containment is part of the correct analysis of logical entailment, defining the content of a statement A as:

the set of all sentences which can be analytically established from $[A]$, using the properties of relations and terms of $[A]$... taken in [its] proper context... Thus, the content $[c(A)]$ is an *analytic closure*.(36, p. 161)

We may note that Brady's definition is, like Carnap and Popper's before it, a class of formulae and shares with them the property that any two contingent statements will share a content part.

We won't go into these particular accounts in any further detail, motivating our leaving them aside due to a common feature. All of the foregoing notions of content are indifferent with respect to the notion of *subject matter*. Where p and q are atomic formulae, each of these definitions demand that the content of the formula p *contains* the content of the complex formula $p \wedge (p \vee q)$. If we consider interpretations in which p and q are heterogeneous in their subject matter—say that one is a statement about arithmetic while the other a line from *The Wind in the Willows*—it might seem far-fetched to suggest that the analysis of the one should include any mention of the other.

In the present case, we will restrict our attention to formalizations of the containment/entailment analogy in which attention is given to subject matter, and will take as the archetypal case the systems in the family of *analytic implication* described by William T. Parry.

1.1.1 Parry's Proscriptive Principle

In the 1930s, such considerations led William T. Parry to attempt to codify this notion of logical containment in his system of analytic implication AI. Parry was a product of the logical school at Harvard led by C. I. Lewis, Henry Sheffer, and Alfred North Whitehead.

Along with Parry, this group that produced many other logicians during the tumultuous early years of non-classical logic, such as Everett Nelson (known for early work on *connexive logic*) and Arnold Emch (who produced early work on *modal logic*). Parry had a profound influence on the development of modal logic proper, with many of the proofs and material in Lewis and Langford's (127) attributed to him.

Parry's system AI was introduced in (143) and expanded to the system PAI in (144). The matter of the axiomatization of Parry's intuitions is somewhat complicated. Although Parry's dissertation (142) included a primitive rule of adjunction, the rule was omitted in the first *published* axiomatization in (143). For a number of reasons, we will prefer to consider the expanded system. Although semantics for PAI were provided by Kit Fine in (81), there is no known semantics with respect to which the first system is complete. Furthermore, Parry's (147) states that the expanded system PAI was always his intent, and was first formalized in an unpublished paper from 1957.

The hallmark of Parry's systems—and of what may be thought of as *containment logics* or *Parry systems* in general—is a strong relevance property called the 'Proscriptive Principle' (**PP**) described in (144, p. 151) as the thesis that:

No formula with analytic implication as main relation holds universally if it has a free variable occurring in the consequent but not the antecedent.

This type of proscription is on its face justified, as the presence of a novel variable in the consequent corresponds to the introduction of new *subject matter*. The plausibility of the thesis that the content of a statement is related to its subject matter thus appears also to support the validity of the formal principle.

A colorful example of the sort of entailment that Parry intends to rule out as valid is explained as follows:

If a system contains the assertion that two points determine a straight line, does

the theorem necessarily follow that either two points determine a straight line or the moon is made of green cheese? No, for the system may contain no terms from which ‘moon,’ *etc.*, can be defined. (144, p. 151)

To the layperson, the deduction of facts nominally about green cheese—at least in part—from the axioms of geometry seems unusual.

Despite its *a priori* plausibility, it should be clear that the Proscriptive Principle is not universally accepted as a constraint on the containment relation between meanings or semantic content. Such a criterion is obviously not respected by Carnap and Popper’s proposals; because any classical consequence of $p \dot{\vee} q$ is *a fortiori* a classical consequence of p , under both definitions, the content of $p \dot{\vee} q$ is contained in the content of p yet flagrantly violates the **PP**.

Despite Gemes’ rejection of the ‘traditional’ definitions, the picture of content inclusion outlined in his (93) and (94) itself contradicts Parry’s Proscriptive Principle. His own theory entails that whenever B is a part of the content of A , then B must also be a part of the content of any A' logically equivalent to A . Formally, the divergence between Parry’s assumptions and those of Gemes is easy to identify. For example, despite the logical equivalence (modulo classical logic) between the complex formula $A \dot{\wedge} (A \dot{\vee} B)$ and A , Parry asserts that the classes of formulae that are analytically entailed by the two are distinct in general (that is, some atom appearing in B does not appear in A). According to Parry, the formula $A \dot{\wedge} (A \dot{\vee} B) \rightarrow$ analytically entails the formula $A \dot{\wedge} (A \dot{\vee} B)$ although (the classically equivalent) formula A fails to analytically entail $A \dot{\vee} B$.

Gemes argues that a notion of content with respect to which classically equivalent statements may differ in content cannot be reconciled with his aims:

[E]mbracing a notion of content that entails an abandonment of classical equivalence would make that notion of content difficult to use for many projects in

the philosophy of science which carry a commitment to classical equivalence.(93, p. 600)

Furthermore, this property immediately reveals the incompatibility between Parry’s project and Brady’s formal analysis of entailment as containment of meaning. The axiomatization in (36) of Brady’s preferred containment logic DJ—a system designed as a characterization of entailments induced by meaning containment—includes axioms such as $A \rightarrow A \dot{\vee} B$. The validity of such entailments immediately conflicts with Parry’s formal property.

In Parry’s own system, the **PP** is a property of *theorems* of **Al**; this property may be called the **PP**[→]—Proscriptive Principle for theorems. Now, consider a language \mathcal{L}_+ that defined with a negation, conjunction, and disjunction connectives, as well as an intensional implication connective \rightarrow , *i.e.*, an implication connective distinct from the material conditional:

Definition 1.1.1. *Let $\mathbf{At} = \{p_0, p_1, \dots\}$ be a denumerable set of atomic formulae. Then the propositional language \mathcal{L}_+ is defined in Backus-Naur form with $p \in \mathbf{At}$:*

$$A ::= p \mid \dot{\neg} A \mid A \dot{\wedge} A \mid A \dot{\vee} A \mid A \rightarrow A$$

Note that the languages in which we will be working are propositional, lacking predicates, quantifiers, and so forth. The matter of interpreting such notions in logics of analytic implication is interesting, but one that will be set aside for future work.

We will in the sequel also refer to a set of literals **Lit**, defined as $\mathbf{At} \cup \{\dot{\neg} p \mid p \in \mathbf{At}\}$. For an arbitrary formula A , let ‘ $\mathbf{At}(A)$ ’ represent the set of atoms in \mathbf{At} that appear in A . Then for a language such as \mathcal{L}_+ , the **PP**[→] may be succinctly described as the following constraint on a deductive system:

$$\mathbf{PP}^{\rightarrow} \text{ If } \vdash A \rightarrow B, \text{ then } \mathbf{At}(B) \subseteq \mathbf{At}(A)$$

However, we will frequently describe deductive systems within a *zeroth degree language* that includes negation, conjunction, and disjunction as its sole logical constants, such as \mathcal{L}_{zdf} :

Definition 1.1.2. Where \mathbf{At} is a denumerable set of atomic formulae, \mathcal{L}_{zdf} is defined in Backus-Naur form with $p \in \mathbf{At}$:

$$A ::= p \mid \neg A \mid A \wedge A \mid A \vee A$$

Because deductive systems defined over \mathcal{L}_{zdf} lack an intensional implication connective (although they admit a definable material conditional connective \supset), the $\mathbf{PP}^{\rightarrow}$ will not be well-defined in these cases. Let the notation $f[X]$ represent the image of a set X under a function f ; in particular, for a collection of formulae Γ , $\mathbf{At}[\Gamma]$ will be the collection of all atoms appearing in some formula in Γ . Then to carry over Parry's intuitions to a first-degree logic, a system will be taken to be a containment logic or a Parry logic if it obeys the condition:

$$\mathbf{PP}^+ \text{ If } \Gamma \vdash B, \text{ then } \mathbf{At}(B) \subseteq \mathbf{At}[\Gamma]$$

Note that Parry's own system fails to obey the \mathbf{PP}^+ .¹

An immediate consequence of $\mathbf{PP}^{\rightarrow}$ and \mathbf{PP}^+ is that each is incompatible with the respective form of the principle of **Addition**. This principle may be characterized either as ranging over formulae of the form $A \rightarrow (A \vee B)$ or ranging over inferences $A \vdash A \vee B$, depending on the type of system considered. For example:

$$\mathbf{Addition}_1 \vdash A \rightarrow (A \vee B)$$

$$\mathbf{Addition}_2 \text{ If } \Gamma \vdash A \text{ then } \Gamma \vdash A \vee B.$$

¹The criticism leveled against Parry by Charles Kielkopf in (120) hinged on this fact; Kielkopf suggested that the inference $A \vDash_{\mathbf{Al}} B \vee \neg B$ reveals a fatal flaw in \mathbf{Al} as $B \vee \neg B$ is not 'analytically contained' in A in Parry's sense. Kielkopf failed to notice, however, that in Parry's system, the double turnstile is read as a truth-theoretic relation, whereas analytic implication—the meaning-theoretic relation—is represented by the connective \rightarrow .

While either species of **Addition** is classically acceptable—indeed, each is acceptable by the lights of almost any deductive system in the literature—Parry justifies the proscription against the validity of **Addition** by claiming that B may ‘introduce new content.’

As some languages contain a conditional connective and others do not, if the spirit of the Proscriptive Principle is to be preserved in the systems in language \mathcal{L} , the property must be made more precise in such contexts. Indeed, the Proscriptive Principle appears in two different forms in the literature; Parry’s principle can be formulated with respect to *logical consequence* or with respect to the implication *connective*. With respect to a set of formulae Γ , recall that $\mathbf{At}[\Gamma]$ denotes the set of all atoms appearing in some $B \in \Gamma$. Then we can distinguish these systems formally by writing:

Definition 1.1.3. *A formal logical system \mathbf{L} is \rightarrow -Parry if it enjoys the property that*

$$\vdash_{\mathbf{L}} A \rightarrow B \text{ only if } \mathbf{At}(B) \subseteq \mathbf{At}(A)$$

Definition 1.1.4. *A formal logical system \mathbf{L} is \vdash -Parry if it enjoys the property that*

$$\Gamma \vdash_{\mathbf{L}} A \text{ only if } \mathbf{At}(A) \subseteq \mathbf{At}[\Gamma]$$

It should be observed that no system can non-vacuously enjoy both these properties. If a system \mathbf{L} is \vdash -Parry, that every formula in \mathcal{L}^+ contains atoms ensures that for no formula $A \rightarrow B \in \mathcal{L}^+$ does $\vDash_{\mathbf{L}} A \rightarrow B$.²

A further consequence of this view, of course, is that the scope of deduction theorems must be very constrained in their scope with respect to Parry-type systems. For example, if a system \mathbf{L} is \vdash -Parry, one cannot infer that $\vdash_{\mathbf{L}} A \rightarrow B$ from $A \vDash_{\mathbf{L}} B$, as theoremhood of $A \rightarrow B$ (*i.e.*, consequence from an empty set of premises) will violate the Proscriptive

²Richard Epstein’s system PD of *paraconsistent dependence logic* introduced in (72) nearly exhibits both properties in that $\Gamma \vDash_{\text{PD}} A$ behaves as a \vdash -Parry system when Γ is nonempty and as a \rightarrow -Parry system when $\Gamma = \emptyset$. The price for this, however, is that PD’s consequence relation violates the familiar Tarskian axioms for such relations.

Principle with respect to the consequence relation. Likewise, if a formula A is logically false in a \rightarrow -Parry system L , although $A \vDash_L B$ for an arbitrary formula B , it cannot thereby be inferred that $\vDash_L A \rightarrow B$, as B may contain propositional variables not found in A .

The two versions of the Proscriptive Principle entail can be identified as special cases of more general conditions corresponding to the selection and placement of atoms in formulae. In particular, whenever a formula $A \rightarrow B$ is a theorem of a \rightarrow -Parry logic, it follows that the antecedent A and consequent B share some variable p , *i.e.*, theoremhood of $A \rightarrow B$ entails that $\mathbf{At}(A) \cap \mathbf{At}(B)$. This condition can be recognized as the famous *variable-sharing property* that is characteristic of propositional relevant logics. This weaker property is that it is a necessary condition on valid inferences that the hypothesis and conclusion have some propositional variable in common.

VSP If $\vdash A \rightarrow B$, then $\mathbf{At}(A) \cap \mathbf{At}(B) \neq \emptyset$

Consequently, Parry-type systems can be thought of as a subspecies of relevant logics. Indeed, many such systems have been introduced with an emphasis placed on their exhibiting the variable-sharing property rather than the Proscriptive Principle. Harry Deutsch's work in (58) and (60) squarely identifies his own systems as relevant, as does the work of Frederick Johnson in (116) and (117).

Just as Parry's Proscriptive Principle admits two formulations, satisfaction of the variable-sharing property can be similarly formulated in two ways.³

Definition 1.1.5. *A formal logical system L is \vdash -relevant if*

$$\Gamma \vdash_L A \text{ only if } \mathbf{At}(A) \cap \mathbf{At}[\Gamma] \neq \emptyset$$

Definition 1.1.6. *A formal logical system L is \rightarrow -relevant if*

³Note that this is sometimes known as 'weak relevance' due to a stronger property of 'depth relevance' described by Ross Brady in (34).

$$\vdash_{\mathbf{L}} A \rightarrow B \text{ only if } \mathbf{At}(A) \cap \mathbf{At}(B) \neq \emptyset$$

Clearly, systems that are \vdash -Parry or \rightarrow -Parry enjoy their respective version of the variable-sharing property.

Observation 1.1.1. *If a system \mathbf{L} is \rightarrow -Parry then \mathbf{L} is \rightarrow -relevant.*

Observation 1.1.2. *If a system \mathbf{L} is \vdash -Parry then \mathbf{L} is \vdash -relevant.*

Some authors, like Deutsch or Johnson, suggest that Parry-type systems, from a semantical viewpoint, more naturally capture matters of relevance than the standard relevant logics like **R** or **E**. (In some contexts—such as the matter of the frame problem mentioned in Richard Sylvan’s paper published in various configurations as (186), (184), and (183)—the *conjunction* of these two characterizations of ‘relevance’ is viewed as attractive.⁴)

Deductive systems that are \vdash -Parry are also instances of a more general class of propositional logics: *paraconsistent* logics. In Section 1.1.2, it was noted that both relevant and Parry-style logics can be thought of as arising from distinct strategies against Lewis’ proof of ECQ. In general, paraconsistent logics are defined as deductive systems whose consequence relations fail to obey ECQ.

Definition 1.1.7. *A logical system \mathbf{L} is paraconsistent if there exist formulae A and B such that*

$$A, \dot{\neg} A \not\vdash_{\mathbf{L}} B$$

Both the relevant and Parry-type strategies are successful in this regard.

In particular, it is clear that a system’s being \vdash -Parry entails that it is paraconsistent as well. For any \vdash -Parry system \mathbf{L} and distinct propositional variables p and q , the Proscriptive Principle entails that $p, \dot{\neg} p \not\vdash_{\mathbf{L}} q$ because $q \notin \mathbf{At}[\{p, \dot{\neg} p\}]$.

⁴Explicitly, Sylvan writes: ‘Evidently the best of both, relevant and containment logics without the defects, can be had by combining the two, essentially product-wise. So result relevant containment logics.’(184, p. 170)

Being able to introduce versions of the Proscriptive Principle and variable-sharing property formulated with respect to both consequence and the conditional connective is useful in that it enables us to study the first-degree fragments of systems with intensional conditional connectives in isolation. For our purposes, we can define a first-degree fragment of a deductive system as follows:

Definition 1.1.8. *With respect to systems L in language \mathcal{L}^+ and L' in \mathcal{L} , L' is the first-degree fragment of L —symbolized by $L' = L_{\text{fde}}$ —if for all $A, B \in \mathcal{L}$:*

$$A \vDash_{L'} B \text{ iff } \vDash_L A \rightarrow B$$

This carries the consequence that L is \rightarrow -Parry only if L_{fde} is \vdash -Parry.

This distinction is especially useful in analyzing the intensional Parry systems, as in many cases their first-degree fragments have appeared independently in the literature.

1.1.2 Proscription as ‘Conceptivism’

Conceptivism—a name originated by Richard Sylvan—is a name for a loose confederation of deductive systems, joined in common resistance to the *Principle of Explosion* or *Ex Contradictione Quodlibet* (ECQ), *i.e.*, that from a contradiction $A \wedge \neg A$, one may infer an arbitrary formula B . (166) provides a taxonomy of such renegade logics, distinguished by the manner in which they resist C. I. Lewis’ demonstration of ECQ in (127). Parry himself considers the distinctions between analytic implication and its rivals through this lens in (147) and (146).

For example, relevant logics—the most widely known family of such systems—reject the inference of *Disjunctive Syllogism*, *i.e.*, that from A and $\neg A \vee B$ one may infer B . Sylvan identifies the position preempting the Lewis proof by rejecting the *Principle of Addition*, *i.e.*, A entails $A \vee B$, as *conceptivism*.

Conceptivism is described at (166, p. 96) in the following terms.

[William] Parry’s position—for which we have coined the ugly term *conceptivism*—is that no implication $A \rightarrow B$ is correct where B contains concepts which do not occur in A . Plainly this makes $A \rightarrow A \dot{\vee} B$ [the principle of Addition] incorrect since B may well, in an obvious sense, ‘contain concepts’ not in A .

The hallmark, according to Sylvan, of conceptivist logics is the rejection of the Principle of Addition.

Relevant logics and other members of this confederation have received the lion’s share of attention in the literature. Apart, however, from a handful of technical papers, conceptivism has been severely neglected in the wake of some particularly sharp criticism of the notion of ‘analytic implication.’ The semantics for PAI and related systems which eventually emerged made it easy to dismiss conceptivist systems as merely imposing a syntactic filter atop other, independently motivated systems, without any independent and robust interpretation of their own.

What we wish to show is that there are clear means of motivating a conceptivist logic that are not subject to the criticism leveled against the field by Sylvan. We will examine a number of trends in logic and linguistics that are suggestive of these systems before providing a robust interpretation supporting the failure of Addition. First, let us survey several of the objections raised against conceptivism.

Much of the criticism of conceptivism stems from questioning whether Parry’s system and others in its neighborhood employ a robust notion of ‘concept’ and, in turn, correctly characterize Kant’s notion of analytic judgment. J. Michael Dunn, for example, introduces Parry’s work by writing that

Parry’s system is intended to be in step with Kant’s notion of *analyticity*. (65, p. 195)

Alan Ross Anderson and Nuel Belnap, Jr. legitimately question whether PAI is successful

with respect to this goal, suggesting at (7, p. 432) that Addition is required for many entailments that should be thought of as analytic in the Kantian sense, *i.e.*, true by definition. *E.g.*, the classic example of ‘all bachelors are unmarried’ is commonly thought to be analytic due to the validity of Conjunctive Simplification. The story goes that the predicate ‘ x is a bachelor’ is identical to ‘ x is a male and x is unmarried’ and so by Conjunctive Simplification, we may infer that

If x is a male and x is unmarried, then x is unmarried.

Anderson and Belnap suggest that it is just as natural to maintain that the predicate ‘ x is a sibling’ is defined as ‘either x is a sister or x is a brother.’ At (6, p. 23), they write that

there is surely a sense in which $A \dot{\vee} B$ is ‘contained’ in A ; *viz.*, the sense in which the concept Sibling (which is most naturally defined as Brother-or-Sister) is contained in the concept Brother. Certainly ‘All brothers are siblings’ would have been regarded as analytic by Kant.

Essentially, Anderson and Belnap attack the ‘analyticity’ of Parry’s system by describing an example of a Kantian analytic judgment whose validity is not reflected in PAI. The argument requires both that we identify the logical form of the judgment ‘All brothers are siblings’ with that of an entailment $A \rightarrow A \dot{\vee} B$, and that we consider the judgment ‘A brother is a sibling’ to be a textbook instance of an analytic judgment in the Kantian sense. Given these assumptions, Anderson and Belnap suggest that PAI—and, indeed, any \rightarrow -Parry logic—is inadequately ‘analytic.’

We will not take up the question of whether these two cases really stand or fall together but merely note that Anderson and Belnap’s example serves, at best, as a critique of PAI *qua* exegesis of Kant.

A further critique of PAI and its neighbors has its origins in a conjecture of Kurt Gödel. In (143), Parry quotes Gödel as remarking that

perhaps ‘ p analytically implies q ’ can be interpreted as ‘ q is derivable from p and the logical axioms and does not include any other concepts than p ’

This falls under the heading of what Sylvan calls a ‘double-barrelled’ analysis in (185, p. 166), where double-barrelled analyses of implicational relations are those that may be reduced to imposing ‘*sieves* or *strainers*, which capture a tighter connection through controlled cases (“sieving”) of a slacker one.’ Gödel’s conjecture that theoremhood in Parry’s system amounts to the conjunction of two theses—that $A \rightarrow B$ is a theorem of some *other*, independently motivated system L and that $\mathbf{At}(B)$ is a subset of $\mathbf{At}(A)$ —‘strains out’ certain cases of implication in L and is thus such a sieve.

In the 1970s, Dunn and Alasdair Urquhart gave semantical analyses of systems related to PAI in the papers (65) and (188), respectively, but the Gödel conjecture was ultimately confirmed by Kit Fine in the paper (81).⁵ Fine’s semantics amounts to an **S4** Kripke model equipped with additional machinery that essentially tracks when, for any two formula A, B , $\mathbf{At}(B) \subseteq \mathbf{At}(A)$. The truth conditions for analytic implication are clearly double-barrelled in Sylvan’s sense; letting γ_u denote a map from \mathbf{At} to a set C of ‘concepts,’ the account is:

$$w \Vdash A \rightarrow B \text{ iff for all } u \text{ such that } wRu, \begin{cases} \text{if } u \Vdash A \text{ then } u \Vdash B, \text{ and} \\ \gamma_u[\mathbf{At}(B)] \subseteq \gamma_u[\mathbf{At}(A)] \end{cases}$$

This reveals the analytic implication of Parry as essentially **S4** strict implication with an additional filter.

Part of why this conclusion came across as destructive to conceptivism seems to be that whereas (supposing L to be sound and complete) a conditional $A \rightarrow B$ can in general receive a semantical characterization, the condition that $\mathbf{At}(B) \subseteq \mathbf{At}(A)$ is frequently described as irreducibly syntactical in nature. In general, providing a semantical interpretation for some feature of a system is essential for showing the intuitions underlying that system to be

⁵Although note that Dunn, too, proves in (65) that a similar property holds for his demodalized DAI

natural. Compare, for example, this to Grzegorzczuk's formal interpretation of intuitionistic logic in (102): his reading of intuitionistic logic as a logic of 'scientific investigation' against classical logic as 'the logic of ontological thought' is reinforced by the semantical picture of (102) and (124) in a way that the axioms alone cannot provide.

Although Fine's device to track when $\mathbf{At}(B) \subseteq \mathbf{At}(A)$ is, strictly speaking, semantical, some have argued that its appeal to syntax fails to provide any deep semantical insight into the notions of 'concept' or 'analysis.' Brady, for example, appeals to precisely this feature in dismissing such a characterization:

[B]eing essentially a syntactic containment, [Fine's 'constitutive content'] is not meaning containment in the sense that we are arguing for. (36, p. 160)

Whether or not Fine's semantics provides any profound insight into psychology or phenomenology, Sylvan and other critics have suggested that the interpretation of the term 'concept' presupposes an isomorphism with that of a propositional variable.

The problem for the larger field of conceptivist logics is that nearly every system introduced in the literature admits such an analysis. Hence, this type of critique against Parry's system as ill-motivated extends to virtually all Parry-type systems introduced in the literature to date. Absent an independent and robust semantical picture, Sylvan argues that the insights provided by Parry-type systems come across as merely parasitic.

On this basis, Sylvan rather vociferously dismisses conceptivist logics, complaining in (166, p. 100) that philosophical worries concerning entailment 'are not repaired simply by throwing on a variable-inclusion filter.' That the semantics for PAI ensures the Proscriptive Principle by such a device leads Sylvan to condemn conceptivism because 'the conceptivist objections do not rest on a solid base, but on a narrow and arbitrary assumption as to what counts as a concept or term.' (166, p. 101) Hence, offered merely as a formalization of Kantian analytic judgments, Parry's system seems to fail.

An intriguing observation is that while Sylvan reads Fine's result as sounding a dirge for conceptivism, Parry himself in (148) greets Fine's results with great enthusiasm; indeed, he suggests that Fine's approach *confirms* his intuitions concerning PAI. Part of Parry's reaction seems to stem from the fact that the interpretation of PAI as a Kantian exegesis is an assumption on the part not of Parry himself, but of his critics. Insight into Parry's preferred interpretation can be found in his PhD dissertation (142). Parry considers Proposition 5.123 of Wittgenstein's *Tractatus*, which reads:

If a god creates a world in which certain propositions are true, he creates thereby also a world in which all propositions consequent on them are true. And similarly he could not create a world in which the proposition '*p*' is true without creating all its objects.

Parry's reply is:

But one might say: 'Could not a god create a world in which the proposition *p* is true, without thereby creating all the objects contained in any other proposition *q*? Then there would be no proposition *q*, or $q \dot{\vee} \dot{\neg} q...$ '

There is certainly room for debate over whether Parry's reply suffices to show that $q \dot{\vee} \dot{\neg} q$ does not follow from *p*. But it is clear that Parry is not committed to the equivalence of his analytic implication with analytic judgments.

Admittedly, Parry's use of the term 'analytic implication' certainly appears to suggest a Kantian motivation. Yet in (144), Parry explicitly cites his primary inspiration as not Kant, but H. M. Sheffer, to whom Parry attributes the original case against Addition. This is reflected well in the discussion of (146):

Our conception of deducibility may be clarified thus: [*B*] is deducible from [*A*] if, in any system in which [*A*] is asserted, the assertion of [*B*] is justifiable,

assuming a reasonably complete logic. Now, we ask, if a system of Euclidean geometry contains the assertion that two points determine a straight line, are we justified in asserting in this system: ‘Either two points determine a straight line or some mice like cheese’? No,. this strange disjunction is not a legitimate assertion in a system of Euclidean geometry, for the simple reason that no such system contains the terms ‘mice’ or ‘cheese’, nor can one define by geometric concepts a type of cheese any self-respecting mouse would nibble at.(146, p. 24)

But this position does not sound Kantian; it speaks of *terms*—syntactical objects—rather than of *meaning* or *content*. Yet the dismissal of Parry’s intuition essentially stems from the supposed conflation of the notions of concept and syntax. As the system is presented *by Parry*, the charges of Anderson, Belnap, and Sylvan seem much less compelling. In a sense, the collapse of the Parry program was illusory; rather than show that Parry’s own intuitions were off the mark, his critics set up a ‘straw program’ and knocked it down.

It is the goal of the present work to explore some themes related to deductive systems satisfying one form of the Proscriptive Principle or other, with a special emphasis placed on the rehabilitation of their study to some degree.

1.2 Overview of the Material

The dissertation is roughly divided into two sections. The first is primarily concerned with interpreting the Proscriptive Principle through the lens of the semantic category of nonsense, with Chapters 2, 3, and 4 considering the relationship between the two in the contexts of linguistics/semantics, metaphysics, and computation, respectively. The second section emphasizes formal and algebraic analysis the family of first-degree Parry logics intermediate between Parry’s PAI_{fde} and Richard B. Angell’s AC, with Chapters 5, 6, and 7 treating this family in the settings of many-valued semantics, Arieli/Avron-style logical bilattices, and

Correia’s 2004 semantics for **AC**.

In Chapter 2—much of which has appeared in the paper (77)—we identify and develop the relationship between Parry-type deductive systems and the field of ‘logics of nonsense.’ Of particular importance is Dmitri Bochvar’s ‘internal’ nonsense logic Σ_0 , and we observe that two \vdash -Parry subsystems of Σ_0 —Harry Deutsch’s S_{fde} and Frederick Johnson’s **RC**—can be considered to be the products of particular ‘strategies’ of eliminating problematic inferences from Bochvar’s system.

The material of Chapter 3 considers Kit Fine’s program of state space semantics in the context of Parry logics. In (87), Fine—who had already provided the first intuitive semantics for Parry’s **PAI** in (81)—offers a formal model of truthmaking (and falsmaking) that provides one of the first natural semantics for Richard B. Angell’s logic of *analytic containment* **AC**, itself a \vdash -Parry system. After discussing the relationship between state space semantics and nonsense, we observe that Fabrice Correia’s weaker framework—introduced in (51) as a semantics for a containment logic weaker than **AC**—tacitly endorses an implausible feature of allowing *hypernonsensical* statements. By modelling Correia’s containment logic within the stronger setting of Fine’s semantics, we are able to retain Correia’s intuitions about factual equivalence without such a commitment. As a further application, we observe that Fine’s setting can resolve some ambiguities in Greg Restall’s own truthmaker semantics of (159).

Chapter 4—which includes material appearing in (73)—we consider interpretations of disjunction that accord with the characteristic failure of **Addition** in which the evaluation of a disjunction $A \dot{\vee} B$ requires not only the truth of one disjunct, but also that *both* disjuncts satisfy some further property. In the setting of computation, such an analysis requires the existence of some procedure tasked with ensuring the satisfaction of this property by both disjuncts. This observation leads to a computational analysis of the relationship between Parry logics and logics of nonsense in which the semantic category of ‘nonsense’ is associated with catastrophic faults in computer programs. In this spirit, we examine semantics for

several \vdash -Parry logics in terms of the successful execution of certain types of programs and the consequences of extending this analysis to dynamic logic and constructive logic.

Chapter 5—which incorporates material that has appeared in (79)—considers these faults in the particular case in which Nuel Belnap’s ‘artificial reasoner’ of (23) and (24) is unable to retrieve the value assigned to a variable. This leads not only to a natural interpretation of Graham Priest’s semantics of (156) for the \vdash -Parry system S_{fde}^* but also a novel, many-valued semantics for Angell’s AC, completeness of which is proven by establishing a correspondence with Correia’s semantics for AC of (49). These many-valued semantics have the additional benefit of allowing us to apply the material in Chapter 2 to the case of AC to define intensional extensions of AC in the spirit of Parry’s PAI.

One particular instance of the type of disjunction central to Chapter 4 is Mel Fitting’s *cut-down disjunction*, outlined in (91). Chapter 6—incorporating material appearing in (76) and (80)—examines cut-down operations in more detail and provides bilattice and trilattice semantics for the \vdash -Parry systems S_{fde} and AC in the style of Ofer Arieli and Arnon Avron’s logical bilattices of (12) or (13). The elegant connection between these systems and logical multilattices supports the fundamentality and naturalness of these logics and, additionally, allows us to extend the epistemic interpretation of bilattices in the tradition of artificial intelligence to these systems.

Finally, the correspondence between the present many-valued semantics for AC and those of Correia is revisited in Chapter 7, which has appeared as the paper (78). The technique that plays an essential role in Chapter 5 is used to characterize a wide class of first-degree calculi intermediate between AC and classical logic in Correia’s setting. This correspondence allows the correction of an incorrect characterization of classical logic in (49) and leads to the question of how to characterize hybrid systems extending Angell’s AC*. Finally, we consider whether this correspondence aids in providing an interpretation to Correia’s first semantics for AC.

Chapter 2

Nonsense and Proscription

In this chapter, we examine the relationship between the logics of nonsense of Bochvar and Halldén and the containment logics in the neighborhood of William Parry's PAI. We detail two strategies for manufacturing containment logics from nonsense logics—taking either connexive and paraconsistent fragments of such systems—and show how systems determined by these techniques have appeared as Frederick Johnson's RC and the system S_{fde} independently discovered by Harry Deutsch and Carlos Oller. In particular, we prove that Johnson's system is precisely the intersection of Bochvar's Σ_0 and Graham Priest's non-symmetrized connexive logic and that the Deutsch-Oller system lies just beneath the intersection of Σ_0 and Priest's paraconsistent LP. We conclude by examining the Deutsch-Oller system in more depth, giving it a characterization in terms of LP and showing that it plays the same role to Harry Deutsch's paraconsistent containment logic S that Aleksandr Zinov'ev's S_1 plays with respect to PAI.

2.1 Introduction and Semantical Preliminaries

A close cousin to containment logics—although the shared genetics may not be immediately clear—is the class of so-called ‘logics of nonsense,’ such as the systems described by Åqvist (1), Bochvar (32), and Halldén (104). The general motivation for such systems is the thesis that formal systems must have something to say about statements that are taken to be ‘nonsense’ or ‘meaningless.’ Bochvar and Halldén each proposed solutions to the semantical paradoxes by calling the problematic sentences—*e.g.*, the Liar or Curry sentences—‘meaningless’ and offered their systems as means to proceed in formal logic while still allowing for such a semantical category. Granted that some syntactic objects are indeed meaningless in this way, these types of systems provide an additional semantic value beyond truth and falsity and formalize logics flexible enough to account for meaningless formulae.

2.2 Nonsense Logics

Logics of nonsense are logical systems which aim to reconcile a theory of deduction with the thesis that some statements are meaningless or nonsense, many of which are summarized in Krystyna Piróg-Rzepecka’s (150). If there are indeed meaningless statements—and such statements cannot be said to be true or false—then the classical, bivalent logic championed by Gottlob Frege and Bertrand Russell is inadequate to give an account of the inferential status of such statements.

The possibility of grammatical yet meaningless statements neither true nor false arises frequently in philosophical contexts. For example, one type of a purportedly meaningless statement is a so-called *category mistake*, *e.g.*, a statement such as ‘the square root of Socrates is irrational’ in which a predicate (‘the square root of x is irrational’) is applied to an object (Socrates) in an apparently nonsensical fashion. The statement is apparently grammatical; whether it is *meaningful* is less clear. It is arguably plausible to suggest that such statements

are indeed nonsense—grammatical yet non-significant—and thus demand that a correct theory of deduction be flexible enough to give accounts of meaningless statements. Logics of nonsense profess to give such a correct theory.

Unlike relevant or constructive logics, there is no unifying formal property delimiting the class of logics of nonsense; what determines this family of deductive systems is the common goal of giving an account of deduction in light of meaningless statements. Even supposing that such an account is necessary, the progenitors of nonsense logic had differing positions on many technical questions, such as the proper ontological category of meaningless statements or whether a nonsensical semantic value ought to be designated.

The proponents of logics of nonsense, chief among them being Dmitri Bochvar and Sören Halldén, agree that the classical propositional calculus is ill-equipped to deal with statements that are *meaningless* or *nonsense* and fail to take a value of either true or false. Yet a theory of meaninglessness presupposes a theory of meaning and meaning is an extraordinarily opaque concept. As the theories we will survey in this chapter were developed against the backdrop of problems of analytic philosophy, we will focus on appearances of the notion of meaninglessness since the publication of Russell and Whitehead's *Principia Mathematica*. Of those, we restrict our attention to three cases that may be thought to necessitate a theory of deduction capable of handling meaningless statements.

To be clear, arriving at a theory of deduction accounting for the category of meaningless statements is not some esoteric task. Hans Reichenbach wrote of Russell's suggestion that such a category be considered in the following terms:

It is the basic idea of [Russell's] theory that the division of linguistic expressions into true and false is not sufficient, that a third category must be introduced which includes meaningless expressions. It seems to me that this is one of the deepest and soundest discoveries of modern logic. (157, p. 37)

A brief note on nomenclature before proceeding: While the following is not uniformly observed by proponents of nonsense logics, the distinction between syntax and semantics demands that some attention is paid to terminology.

We use the terms ‘sentence,’ ‘statement,’ and ‘formula’ to denote a syntactic item, a certain type of string of symbols. The term ‘proposition’ is used to denote a semantic or intensional item corresponding to the meaning of the sentence. This usage is by no means standard; *e.g.*, the positivists at times used the term ‘statement’ to refer only to a *meaningful* string of symbols, the term ‘pseudo-statement’ being awarded to the remainder of syntactic items. In this chapter, we will remain ontologically neutral, putting aside the question of whether a ‘meaningless proposition’ is a contradiction in terms.

As logics of nonsense were first described in order to address problems of meaninglessness in early twentieth century analytic philosophy, we will survey three occasions in which meaninglessness or nonsense emerge in this tradition.

2.2.1 Semantic Paradoxes

Semantic paradoxes have been discussed in one form or another since at least Epimenides of Knossos. A very simple version is the Liar sentence, the statement ‘this sentence is false’: its truth seems to entail its falsehood while its falsehood entails its truth. The instance of such paradoxes that drove the development of Bochvar and Halldén’s systems was presented in Whitehead and Russell’s *Principia Mathematica*, in which such paradoxes of self-reference are dismissed by appeal to a *syntactic* notion of meaninglessness.

We need not rehearse the formalism of the *Principia* to describe the problem. In *Introduction to Mathematical Philosophy*, Russell gives a sketch of the type of semantical paradox which he is interested in solving and how the theory of types is intended to resolve it. In the background is the assumption that for any property P , there exists a class of all objects of which P is true. The particular paradox is this:

From... the assemblage [class] of all classes which are not members of themselves. This is a class: is it a member of itself or not? If it is, it is one of those classes which are not members of themselves, *i.e.*, it is not a member of itself. If it is not, it is not one of those classes that are not members of themselves, *i.e.*, it is a member of itself. (170, p. 136)

By the Principle of Excluded Middle, either this class—which Russell calls ‘ κ ’—is a member of itself or not; yet that each entails the contradiction that both $\kappa \in \kappa$ and $\text{not-}\kappa \in \kappa$ implies that the statement ‘ $\kappa \in \kappa$ ’ is both true and false. This is problematic because classically, a contradiction entails all propositions and hence all sentences are true in this theory of classes.

Among the various solutions to this problem described by Russell is one in which problem cases are cleared away *syntactically* at the level of *language*. By iteratively constructing the formal language in which we work, Russell shows that one can banish self-reference in the language itself. In the type of language Russell describes, the statement ‘such-and-such a class is a member of itself’ can be prevented from entering the language at every stage. In such a setting, self-referential statements are *syntactically ill-formed* and are therefore meaningless.

In Russell’s words,

a statement which appears to be about a class will only be significant [meaningful] if it is capable of translation into a form in which no mention is made of the class.
(170, p. 137)

The class κ cannot be defined without such self-reference; the term ‘class of all classes not members of themselves’ is thus a *pseudo-name*, a syntactical object that does not denote. And according to Russell’s solution,

a sentence or set of symbols in which such pseudo-names occur in wrong ways is not false, but strictly devoid of meaning. The supposition that a class is, or that it is not, a member of itself is meaningless in just this way.(170, p. 137)

The resolution offered by Russell thus appears to demand that certain statements (or statement-like objects) are neither true nor false but are rather *nonsense*. Hence, the statement ' $\kappa \in \kappa$ ' is not both true and false and the problem is purportedly resolved.

Importantly, this resolves apparent nonsense by appeal to syntax, *i.e.*, the recursive rules for a language should prevent ' $\kappa \in \kappa$ ' from ever appearing and it is thus an *ill-formed* string of symbols. In the introduction to Wittgenstein's *Tractatus Logico-Philosophicus*, Russell writes that 'a logically perfect language has rules of syntax which prevent nonsense'(196, p. 8), *i.e.*, a *correct* account of language would dissolve occasions of nonsense before they could even arise.

2.2.2 Positivism and Verifiability

The early twentieth century philosophical movement known as *logical positivism* gives a further appearance of a precise treatment of meaninglessness or nonsense both related to and contemporary with the issues raised by Russell.

A central theme in logical positivism is the *verifiability* or *empiricist criterion of meaning*. Hempel describes this criterion as:

A sentence makes a cognitively meaningful assertion, and thus can be said to be either true or false, only if it is either (1) analytic [logically true] or self-contradictory [logically false] or (2) capable, at least in principle, of experiential test.(106, p. 108)

We will set aside the nuances of such a principle, such as the feasibility of verification or the necessity of falsifiability as these are all variations on the same theme. Note however,

that a criterion of *meaningfulness* gives rise to a criterion of *meaninglessness* as well; those statements not satisfying the criterion will be meaningless.

Importantly, a number of claims fail to meet these criteria; wielding the verifiability criterion precludes a great number of statements from being counted as meaningful propositions, *e.g.*, ethical, theological, and metaphysical theses are judged to be nonsense. Much of the effort of the logical positivists was hence directed at defusing (or, more emphatically, ‘eliminating’) philosophical traditions such as ethics or metaphysics, employing the criterion to dismiss their central theses and points of debate as meaningless.

Rudolph Carnap, for example, initially distinguishes between three types of meaningless statements (or ‘pseudo-statements’): Those meaningless in virtue of containing a meaningless term such as ‘good,’ those meaningless in virtue of being ill-formed, and those meaningless in virtue of ‘type confusion.’ In the first case, a sentence such as, ‘This is teavy’ is meaningless because an artificial term like ‘teavy’ is nonsensical and thus cannot be employed in an empirical test of the statement.

More importantly, Carnap’s examples for the second case and third cases are ‘Caesar is and’ and ‘Caesar is a prime number.’ The former is clearly ill-formed as this string cannot be formed by the usual rules of English syntax. According to Carnap, the latter is meaningless in virtue of the fact that the predicate ‘...is a prime number’ can ‘be neither affirmed nor denied of a person.’ (39, p. 68)

Interestingly, in many of the logical positivists’ theories, nonsensical statements of the third kind are in fact instances of the second kind of nonsense, that is, despite appearing to be syntactically well-constructed sentences, they are *ill-formed*. In a perfect language, something implicitly similar to Russell’s typing ought to occur, so that the verb phrase ‘...is a prime number’ would fail to syntactically apply to a noun phrase such as ‘Caesar.’

Carnap writes:

If, *e.g.*, nouns were grammatically subdivided into several kinds of words, ac-

ording as they designated properties of physical objects, of numbers etc., then the words ‘general’ and ‘prime number’ would belong to grammatically different word-categories, and [‘Caesar is a prime number’] would be just as linguistically incorrect as [‘Caesar is and’]. In a correctly constructed language, therefore, all nonsensical sequences of words would be of the kind of [‘Caesar is and’].(39, p. 68)

That we fail to recognize this fact is diagnosed as an artifact of the imperfections of our own natural language. Hence, from the standpoint of the logical positivists, as for Russell, meaninglessness tends to be reducible to ill-formedness. But this is not the only resolution available.

2.2.3 Category Mistakes

Prior to this syntactical observation, there is a sense in which both Russell’s rejection of the meaningfulness of ‘ $\kappa \in \kappa$ ’ and Carnap’s dismissal of the statement ‘Caesar is a prime number’ are instances of a more general notion. Suggesting that the propositional function $\hat{x}.x \in \kappa$ cannot be applied to κ or that ‘is a prime number’ is not the sort of predicate which may be asserted of a man suggests that the subject is of the *wrong category*; these are each occasions of making a *category mistake*.

Gilbert Ryle introduces this term in his 1949 book *The Concept of Mind*, defining the making of a category mistake as the treating of objects ‘as if they belonged to one logical type or category (or range of types or categories when they actually belong to another.’(171, p. 16) The primary philosophical thesis is that, contra Descartes, taking the language and intuitions behind our experience of the *physical* world and applying them to the *mental* leads to illicit inferences. As the physical and mental are of different types, predicates applying to the former are not merely *false* of the latter, but lead to meaningless statements.

Importantly, throughout the work, Ryle continually associates making a category mistake

with uttering nonsense.

It is nonsense to speak of knowing, or not knowing, this clap of thunder or that twinge of pain, this coloured surface or that act of drawing a conclusion or seeing a joke; these are accusatives of the wrong types to follow the verb ‘to know.’ (171, p. 161)

As a result, on Ryle’s account, Cartesian philosophy is not merely *false*, it is literally *nonsense*.

Following Ryle, the theory of category mistakes has been taken up by a number of authors independently of the questions raised by Russell or Carnap. Importantly, in the literature on category mistakes (also, ‘type crossings’) the emphasis on syntactical ill-formedness of such statements is eschewed in favor of more semantically-oriented analyses.

Works such as Theodore Drange’s *Type Crossings* ((64)) and Shalom Lappin’s *Sorts, Ontology, and Metaphor* ((125)) tend to assume that such statements are semantically evaluable. There are, to be sure, debates concerning *how* to evaluate such statements, but it tends to be taken for granted that the problematic statements are, in general, well-formed. Note that this does not necessarily demand a novel logic of nonsense nor a new semantic value. It is perfectly coherent to either assign these statements values of truth and falsity at random or uniformly evaluate them as true or false.

Drange’s own account, for example, is that such category mistakes (which he calls ‘type crossings’) are well-formed and express propositions, albeit propositions that are ‘unthinkable.’ On Drange’s account, there is no way that one can conceive of a state affairs in which a proposition such as that expressed by ‘Caesar is a prime number’ turns out true. This does *not* entail that the sentence is meaningless, although it does bear the consequence that ‘Caesar is a prime number’ is false.

This position—that nonsensical sentences are false—is like Russell and Carnap’s appeal

to syntax in that it precludes a need for a logic of nonsense.

2.2.4 Many-Valued Semantics for Two Nonsense Logics

Bochvar and Halldén’s systems each distinguish two *types* of connectives: On the one hand are the connectives whose truth functions that output a ‘nonsense’ value whenever one or more of their arguments contain a ‘nonsense’ value. The semantical value of nonsense is thus ‘infectious’ or ‘contaminating’ with respect to such connectives, a property that Åqvist colorfully labels the ‘doctrine of the predominance of the atheoretical element’ in (1). Such connectives—described by Bochvar and Halldén as ‘internal’ or ‘classical’—are identified with the operations employed in, *e.g.*, the *Principia Mathematica*. The languages employed by Bochvar and Halldén complement these connectives with so-called ‘external’ connectives whose corresponding truth functions map *all* arguments to ‘meaningful’ values, *i.e.*, either truth or falsity. For example, Halldén intends for his unary ‘meaningfulness’ connective $+$ to evaluate meaningless statements as false and to evaluate meaningful statements as true.

For present purposes, we look at the fragments of Bochvar and Halldén’s logics corresponding to only these ‘internal’ connectives. By ‘ Σ_0 ’ and ‘ C_0 ,’ we denote the systems that (48) describes as the ‘classical fragments’ of the nonsense logics of Bochvar and Halldén, *i.e.*, the systems restricted to ‘internal’ negation, disjunction, and conjunction. Consequence with respect to the systems Σ_0 and C_0 can be defined by a standard account of many-valued semantics. We will follow the presentation in (33) and consider binary consequence relations induced by logical matrices.

Definition 2.2.1. A logical matrix \mathfrak{M} for \mathcal{L}_{zdf} is a 5-tuple $\langle \mathcal{V}_{\mathfrak{M}}, \mathcal{D}_{\mathfrak{M}}, f_{\mathfrak{M}}^{\neg}, f_{\mathfrak{M}}^{\wedge}, f_{\mathfrak{M}}^{\vee} \rangle$ where:

- $\mathcal{V}_{\mathfrak{M}}$ is a nonempty set of truth values
- $\mathcal{D}_{\mathfrak{M}} \subseteq \mathcal{V}_{\mathfrak{M}}$ is a nonempty set of designated values

- $f_{\mathfrak{M}}^{\dot{\neg}}$ is a unary truth function on $\mathcal{V}_{\mathfrak{M}}$
- $f_{\mathfrak{M}}^{\dot{\wedge}}$ and $f_{\mathfrak{M}}^{\dot{\vee}}$ are binary truth functions on $\mathcal{V}_{\mathfrak{M}}$

Definition 2.2.2. Let $\mathfrak{M} = \langle \mathcal{V}_{\mathfrak{M}}, \mathcal{D}_{\mathfrak{M}}, f_{\mathfrak{M}}^{\dot{\neg}}, f_{\mathfrak{M}}^{\dot{\wedge}}, f_{\mathfrak{M}}^{\dot{\vee}} \rangle$. Then an \mathfrak{M} valuation v is a function $v : \mathbf{At} \rightarrow \mathcal{V}$ extended to \mathcal{L}_{zaf} by the recursive scheme:

- $v(\dot{\neg} A) = f_{\mathfrak{M}}^{\dot{\neg}}(v(A))$
- $v(A \dot{\wedge} B) = f_{\mathfrak{M}}^{\dot{\wedge}}(v(A), v(B))$
- $v(A \dot{\vee} B) = f_{\mathfrak{M}}^{\dot{\vee}}(v(A), v(B))$

Definition 2.2.3. A logical matrix \mathfrak{M} characterizes a consequence relation for \mathbf{L} if

$\Gamma \vdash_{\mathbf{L}} A$ holds iff for all \mathfrak{M} valuations v such that $v[\Gamma] \in \mathcal{D}_{\mathfrak{M}}$, also $v(A) \in \mathcal{D}_{\mathfrak{M}}$.

In the sequel, when \mathbf{L} is a deductive system characterized by \mathfrak{M} we will slightly abuse notation and conflate \mathbf{L} with \mathfrak{M} so that, *e.g.*, we will call an \mathfrak{M} valuation an ‘ \mathbf{L} valuation.’

Definition 2.2.4. Σ_0 —the classical fragment of Bochvar’s Σ —is the consequence relation induced by the matrix $\mathfrak{M}_{\Sigma_0} = \langle \mathcal{V}_{\Sigma_0}, \mathcal{D}_{\Sigma_0}, f_{\Sigma_0}^{\dot{\neg}}, f_{\Sigma_0}^{\dot{\wedge}}, f_{\Sigma_0}^{\dot{\vee}} \rangle$ where $\mathcal{V}_{\Sigma_0} = \{\mathbf{t}, \mathbf{u}, \mathbf{f}\}$ and $\mathcal{D}_{\Sigma_0} = \{\mathbf{t}\}$. The truth-functions $f_{\Sigma_0}^{\dot{\neg}}$, $f_{\Sigma_0}^{\dot{\vee}}$, and $f_{\Sigma_0}^{\dot{\wedge}}$ are represented by the matrices:

$f_{\Sigma_0}^{\dot{\neg}}$		$f_{\Sigma_0}^{\dot{\wedge}}$	\mathbf{t}	\mathbf{u}	\mathbf{f}	$f_{\Sigma_0}^{\dot{\vee}}$	\mathbf{t}	\mathbf{u}	\mathbf{f}
\mathbf{t}	\mathbf{f}	\mathbf{t}	\mathbf{t}	\mathbf{u}	\mathbf{f}	\mathbf{t}	\mathbf{t}	\mathbf{u}	\mathbf{t}
\mathbf{u}	\mathbf{u}	\mathbf{u}	\mathbf{u}	\mathbf{u}	\mathbf{u}	\mathbf{u}	\mathbf{u}	\mathbf{u}	\mathbf{u}
\mathbf{f}	\mathbf{t}	\mathbf{f}	\mathbf{f}	\mathbf{u}	\mathbf{f}	\mathbf{f}	\mathbf{t}	\mathbf{u}	\mathbf{f}

We also may note that the matrices provided are equivalent to the *weak tables* of Kleene. It is fair to think of the classical fragment of Σ_0 as the weak logic described—and rejected—by Kleene in (122, p. 334).

The logic \mathbf{C}_0 —the classical fragment of Halldén’s \mathbf{C} without the unary meaningfulness operator—differs from Σ_0 only with respect to its set of designated values.

Definition 2.2.5. C_0 is the consequence relation induced by the matrix $\mathfrak{M}_{C_0} = \langle \mathcal{V}_{C_0}, \mathcal{D}_{C_0}, f_{C_0}^{\dot{\neg}}, f_{C_0}^{\dot{\wedge}}, f_{C_0}^{\dot{\vee}} \rangle$ where:

- $\mathcal{V}_{C_0} = \mathcal{V}_{\Sigma_0}$
- $\mathcal{D}_{C_0} = \{\mathbf{t}, \mathbf{u}\}$
- $f_{C_0}^{\circ} = f_{\Sigma_0}^{\circ}$ for $\circ \in \{\dot{\neg}, \dot{\wedge}, \dot{\vee}\}$

Now, given Halldén’s ‘...is meaningful’ operator $+$ and Bochvar’s ‘...is true’ operator \mathbf{T} , one can embed classical logic within the full systems; hence, the \mathbf{PP}^+ will not hold in C or Σ . Even in the classical fragments Σ_0 and C_0 *without* projection operators, this property fails. However, in special cases, the \mathbf{PP}^+ holds and Addition fails; moreover, studying *why* the \mathbf{PP}^+ fails is instructive and yields a road map of sorts for transforming logics of nonsense into containment logics.

An observation important to this end is that with respect to a logic of nonsense, four theses jointly entail the \mathbf{PP}^+ . Recall that when v is a valuation and Γ is a set of formulae, $v[\Gamma]$ represents the image of Γ under v . Then:

Observation 2.2.1. *Suppose that in a semantical presentation of a logic L*

1. *‘nonsense’ values are infectious, i.e., for any n -tuple of truth values $\vec{\mathbf{v}}$ in which a nonsense value appears and an n -ary truth-function f , $f(\vec{\mathbf{v}})$ is a nonsense value,*
2. *‘nonsense’ values are not designated,*
3. *every set of formulae Γ has a valuation v such that $v[\Gamma] \subseteq \mathcal{D}_L$, and*
4. *$\Gamma \models_L B$ is read as ‘every valuation assigning all $A \in \Gamma$ designated values also assigns B a designated value’*

Then L obeys the \mathbf{PP}^+ .

Proof. Suppose that L enjoys the above four properties and suppose for contradiction that $\Gamma \vDash_L B$ while some atom in B is not found in any $A \in \Gamma$. Let C be an atom witnessing this fact. Now, Γ [from 3] has a valuation v in which all $A \in \Gamma$ are designated. Consider a valuation v' identical to v except for its mapping C to a nonsense value. Since $C \notin \mathbf{At}[\Gamma]$, all $A \in \Gamma$ remain designated. Since $C \in \mathbf{At}(B)$, B is assigned a nonsense value by v' [from 1] and such a value is not designated [from 2]. Given the traditional, semantic reading of $\Gamma \vDash_L B$ [from 4], we infer that $\Gamma \not\vDash_L B$. \square

The \mathbf{PP}^+ fails in the classical fragment of Halldén's system because the meaningless value is designated.¹ To wit, it can be easily checked that $A \vDash_{\mathbf{C}_0} A \dot{\vee} B$. In Bochvar's system this inference fails in general—that A is true *does not* entail that $A \dot{\vee} B$ is true as B , after all, could be meaningless, rendering the disjunction meaningless. Nevertheless, the \mathbf{PP}^+ fails in Bochvar's system. Σ_0 does not tolerate contradictions, *i.e.*, contradictions cannot take a designated value, and hence, $A \dot{\wedge} \dot{\neg} A \vDash_{\Sigma_0} B$ holds vacuously. The \mathbf{PP}^+ holds, on the other hand, for consistent premises.

This clearly lays out a means to construct a Parry system from a logic of nonsense. The central question is that of the inferential status of sets of formula Γ which have no valuations mapping their formulae to designated values; the existence of such sets prevents Σ_0 from enjoying the \mathbf{PP}^+ . We may consider two strategies for weakening Σ_0 to a nonsense logic. One strategy is to *inferentially quarantine* such sets of formula by allowing nothing to be inferred from contradictory premises; this entails rewriting the usual rules for turnstile. A second strategy is to *homogenize* formulae so that all non-empty sets not only have models, but that inconsistent sets will maintain a similar inferential behavior to that of sets of consistent formulae.

¹*Cf.* (104, p. 47) for Halldén's explanation and defense of this feature.

2.3 Two Strategies for Containment

The relationship between nonsense logics and containment logics is underscored by the ways in which Parry logics can be generated from nonsense logics. To illustrate, we will consider Bochvar's Σ_0 and provide two strategies to yield a fragment that qualifies as a containment logic. The first strategy is to consider what may be thought of as a *connexive fragment* of Σ_0 and the second is to consider a *paraconsistent* fragment. In Chapter 4, we will add a third strategy, by showing the intuitionistic, implicational fragment of Σ_0 is also a containment logic.

2.3.1 Containment Through Connexivity: Johnson's RC

Parry's AI was not the only cousin of (or competitor to) relevant logics to receive space in Anderson and Belnap's (7). Additionally, pages were set aside to provide an account and examination of *connexive logics*, although the systems described therein—due to Storrs McCall—are distinct from the connexive logics we will employ in the sequel.

What we wish to show in this section is that by employing connexive principles along the lines of (155), one may make use of the proof of Observation 2.2.1 to generate a containment logic from a logic of nonsense. Indeed, what we will show is that such a system has already appeared as the containment logic RC introduced by Frederick Johnson in (116) and that it is the intersection of the classical fragment of Bochvar's Σ_0 and a connexive logic described by Graham Priest in (155).

The characteristic feature of connexive logics is the satisfaction of a pair of theses governing the behavior of implication, *Aristotle's Thesis*:

$$\mathbf{AT}^{\rightarrow} \quad \dot{\neg}(A \rightarrow \dot{\neg} A)$$

and *Boethius' Thesis*:

$$\mathbf{BT}^{\rightarrow} \dot{\neg}[(A \rightarrow B) \wedge (A \rightarrow \dot{\neg} B)]^2$$

Similar principles can be captured as metalinguistic statements as well:

$$\mathbf{AT}^{\vdash} \text{ For all } A, A \not\vdash \dot{\neg} A$$

$$\mathbf{BT}^{\vdash} \text{ For all } A, B, \text{ if } A \vdash B \text{ then } A \not\vdash \dot{\neg} B$$

Now, there is a subtle distinction between the two formulations of these theses. That the symbol ‘ $\dot{\neg}$ ’ appears twice in $\mathbf{AT}^{\rightarrow}$ suggests that each instance is a species of the same type of negation, yet this is not necessarily the case with respect to its metalinguistic counterpart \mathbf{AT}^{\vdash} . The metalinguistic negation indicated by $\not\vdash$ and the object language negation symbolized by $\dot{\neg}$ may very well diverge in meaning. We must thus content ourselves with the claim that $\mathbf{AT}^{\rightarrow}$ and \mathbf{AT}^{\vdash} are similar, rather than identical, principles.

Proposals abound as to how to properly motivate connexive logics, ranging from the thesis that such systems capture the subjunctive conditional (defended by Richard Angell in (8), where $\mathbf{AT}^{\rightarrow}$ is called the ‘principle of subjunctive contrariety’) to the thesis that negation ‘cancels’ or ‘annihilates’ an affirmation (described, but *not* defended, by Priest in (155)). McCall’s (131) and Heinrich Wansing’s (193) provide thorough surveys of the history, philosophy, and motivation of connexive principles; for a deeper discussion of these matters, the reader is referred to these sources.

To tie this to the strategy of inferential quarantine, note that there is an apparently very obvious motivation for why one might expect \mathbf{AT}^{\vdash} and \mathbf{BT}^{\vdash} to hold. With respect to contingent formulae—those formulae having a model in which they are verified and one in which they are not—classical logic satisfies these principles.

Observation 2.3.1. *If A and B are classically contingent, then if $A \vDash_{\text{CL}} B$ then $A \not\vdash_{\text{CL}} \dot{\neg} B$*

² \mathbf{BT} is typically stated as $(A \rightarrow B) \rightarrow \dot{\neg}(A \rightarrow \dot{\neg} B)$ in the literature on connexive logic. Priest’s formulation from (155) (which we employ in this chapter) has been called ‘Strawson’s Thesis’ due to P.F. Strawson’s endorsement of the principle in (181). Priest’s formulation bears a strong resemblance to the formula $(A \rightarrow B) \supset \dot{\neg}(A \rightarrow \dot{\neg} B)$, called ‘weak Boethius’ Thesis’ by Pizzi and Williamson in (151).

Proof. Suppose that $A \vDash_{\text{CL}} \dot{\neg} B$; then from $A \vDash_{\text{CL}} B$ and $A \vDash_{\text{CL}} \dot{\neg} B$, we may infer that $A \vDash_{\text{CL}} B \wedge \dot{\neg} B$. This can only hold if A is itself a contradiction, from which we infer that it is not the case that both A and B are classically contingent. \square

Observation 2.3.2. *If A is classically contingent then $A \not\vDash_{\text{CL}} \dot{\neg} A$*

Proof. Immediate from Observation 2.3.1, substituting A for B and noting that $A \vDash_{\text{CL}} A$. \square

Implicitly employing these observations, Priest introduced a pair of connexive logics—with ‘plain’ and ‘symmetrized’ versions—in (155). We will call these P_N and P_S , respectively, and will consider their respective consequence relations to be defined over the language \mathcal{L}_+ from Definition 1.1.1.

The systems share a model structure and we will thus define models for P_N and P_S in tandem:

Definition 2.3.1. *Models for P_N and P_S are 3-tuples $\langle W, g, V \rangle$, where W is a set of points such that $g \in W$ and V is a function mapping \mathbf{At} to subsets of W .*

As the two systems interpret the conditional connective differently, we must define distinct forcing relations,³ defined identically for all cases with the exception of the truth condition for \rightarrow . Following (155), we represent the condition peculiar to the symmetrized system P_S in square brackets:

- $w \Vdash A$ iff $w \in V(A)$ for $A \in \mathbf{At}$
- $w \Vdash \dot{\neg} A$ iff $w \not\Vdash A$
- $w \Vdash A \wedge B$ iff $w \Vdash A$ and $w \Vdash B$
- $w \Vdash A \dot{\vee} B$ iff $w \Vdash A$ or $w \Vdash B$

³In a number of works (e.g., (88) and (178)), Melvin Fitting and Raymond Smullyan have detailed the intimate relationship between Cohen’s forcing introduced in (46) and (47) and the relation of truth-at-a-world in Kripke models. The term ‘forcing relation’ is frequently used to describe truth-at-a-world in models with possible worlds, even in contexts in which the strict analogy with Cohen forcing is lost.

$$\bullet w \Vdash A \rightarrow B \text{ iff } \left\{ \begin{array}{l} \exists w' \in W \text{ such that } w' \Vdash A, \\ \forall w' \in W, \text{ if } w' \Vdash A \text{ then } w' \Vdash B \\ \text{[and } \exists w' \in W \text{ such that } w' \not\Vdash B] \end{array} \right.$$

We will call the relation for P_N (without the clause in square brackets) \Vdash_{P_N} and that for P_S (with the clause in square brackets) \Vdash_{P_S} .

We are thus now able to define the notion of validity for the two systems.

Definition 2.3.2. P_N validity

$$\Gamma \vDash_{P_N} A \text{ if } \left\{ \begin{array}{l} \text{there is an } \mathcal{M} \text{ such that for all } B \in \Gamma, g \Vdash_{P_N} B \\ \text{for all } \mathcal{M} \text{ such that for all } B \in \Gamma, \mathcal{M}, g \Vdash_{P_N} B, \text{ also } g \Vdash_{P_N} A \end{array} \right.$$

P_S validity is defined in an analogous fashion, substituting \Vdash_{P_S} for \Vdash_{P_N} .

Priest's approach has appeared in various forms in other contexts; *e.g.*, David Lewis offers a conditional connective $\Box \Rightarrow$ in (128) that determines a weak subsystem of Priest's system P_N . In (151), Claudio Pizzi and Timothy Williamson also indirectly describe another subsystem of Priest's P_N , although its semantics are couched in terms of a conditional logic rather than a logic of strict implication (*cf.* (75)).

A further (and isolated) appearance of this approach is found in Frederick Johnson's containment logic RC described in (116). Johnson was interested in identifying a simple and natural means of precluding C.I. Lewis' famous argument for the principle of *explosion* found in (127), where explosion is the validity of an inference to an arbitrary formula from a contradiction. Concerned with the apparent *irrelevance* of the consequent to the antecedent in such an inference, Johnson aligned his system—described as 'syntactic relevance entailment'—with the field of relevant logics rather than with containment or connexive logics. Neither of the latter themes is mentioned in the paper. Even in the later (117), in

which a related system is introduced, that the system enjoys the \mathbf{PP}^+ is mentioned only *en passant*.

The system RC is semantically described by recalling the logical matrix \mathfrak{M}_{Σ_0} from Definition 2.2.4, in which \mathbf{t} the only designated value.

Definition 2.3.3. *Consequence in the system RC is defined so that:*

$$\Gamma \vDash_{\text{RC}} A \text{ if } \begin{cases} \text{there is a } \Sigma_0 \text{ valuation } v \text{ such that for all } B \in \Gamma, v(B) = \mathbf{t} \\ \text{for all } \Sigma_0 \text{ valuations } v \text{ s.t. for all } B \in \Gamma, v(B) = \mathbf{t}, \text{ also } v(A) = \mathbf{t} \end{cases}$$

Although it is probably clear that RC is a subsystem of both Σ_0 and \mathbf{P}_N , we are able to obtain an even stronger result:

Observation 2.3.3. $\text{RC} = \mathbf{P}_N \cap \Sigma_0$

Proof. We first note that the matrices Johnson provides for RC are Bochvar's matrices for Σ_0 . As validity in Σ_0 is a necessary condition for validity in RC, $\text{RC} \subseteq \Sigma_0$.

Moreover, if the inference $\Gamma \vDash A$ is RC valid, then we may infer a number of things. For one, we require that Γ must be non-empty. Were it empty, then all Σ_0 valuations would vacuously map each of its members to \mathbf{t} ; by the definition of validity, this would entail that all Σ_0 valuations map A to \mathbf{t} , *i.e.*, that A is a theorem of Σ_0 . But Σ_0 has no theorems. Furthermore, we infer that there exists a Σ_0 valuation v by which all formulae in $\Gamma \cup \{A\}$ are designated. Any such valuation, however, restricted to $\mathbf{At}[\Gamma]$ is classical, *i.e.*, the image of $\mathbf{At}[\Gamma]$ under v is $\{\mathbf{t}, \mathbf{f}\}$. (Otherwise, granted the infectiousness of \mathbf{u} , $v(B) = \mathbf{u}$ for some $B \in \Gamma$.) As $v[\Gamma]$ depends only on the values assigned to $\mathbf{At}[\Gamma]$, we may construct a function v' such that

$$v'(B) = \begin{cases} v(B) & \text{if } B \in \mathbf{At}[\Gamma] \\ \mathbf{f} & \text{otherwise} \end{cases}$$

The range of v' is $\{\mathbf{t}, \mathbf{f}\}$ and v' is thus a classical valuation mapping all formulae in Γ to \mathbf{t} , which is just to say that Γ is classically consistent. Additionally, as Σ_0 is a subsystem of classical logic, Γ classically entails A . From these two considerations, we infer that $\Gamma \vDash_{\mathbf{P}_N} A$, whence $\mathbf{RC} \subseteq \mathbf{P}_N$.

Suppose that an inference $\Gamma \vDash A$ is both \mathbf{P}_N - and Σ_0 valid. Then $\Gamma \vDash_{\Sigma_0} A$ holds either vacuously or it does not. The inference *cannot* hold vacuously; were it to do so, then there would be no Σ_0 valuations granting every $B \in \Gamma$ a designated value and thus, *a fortiori*, no classical valuations. But this would imply that Γ is classically a contradiction, entailing that $\Gamma \not\vDash_{\mathbf{P}_N} A$ and contradicting the hypothesis. Hence, there *is* a Σ_0 valuation mapping all $B \in \Gamma$ to designated values and in all such valuations A receives a designated value; but this is just to say that $\Gamma \vDash_{\mathbf{RC}} A$. □

It is extraordinarily interesting that the conjunction of two unrelated theses concerning implication—that of formally accommodating meaninglessness and that of cancellation negation—should prove equivalent to an entirely distinct intuition, that of Johnson.

The system \mathbf{RC} is not without problems. Most disastrous of these is that, as in \mathbf{P}_N , the inference $A \vDash_{\mathbf{RC}} A$ is not valid. While the account given by Priest of \mathbf{P}_N makes some sense of the failure of this inference, it is not clear that Priest's story serves to resolve such a pathology in the context of \mathbf{RC} .

Quarantining the problematic cases is not the only strategy; we have also mentioned a strategy of *homogenizing* inference. Merely providing all sets of sentences with a model is of little use if such models are trivial; rather, we may want a way to maintain nontrivial yet inconsistent models. This can be performed by taking a *paraconsistent* fragment of a nonsense logic.

2.3.2 Containment Through Paraconsistency: The System S_{fde}

As Parry was a student of Lewis, it is not surprising that many of the ‘paradoxes’ of implication, *e.g.*, the principle of explosion, were of concern to him. As noted in the case of Johnson, such an inference is in some quarters taken to be suspicious due to a lack of relevance between the antecedent and consequent.

As shown in Observations 1.1.1 and 1.1.2, the relationship between Parry’s system and relevant logic is a clear one: Relevant logics enjoy the *variable-sharing property*, establishing all Parry systems as relevant logics. But if we take the notion of relevance as a desideratum seriously, even in PAI, there are theorems in which apparent irrelevance arises. The PAI theorem

$$((A \dot{\wedge} \dot{\neg} A) \dot{\wedge} B) \rightarrow \dot{\neg} B$$

might arouse—and has indeed aroused—similar suspicions. Harry Deutsch describes this as ‘the fallacy of making too much of one small, if nasty, mistake’ (59, p. 139) and asserts that this principle is as suspicious as the principle of explosion.

Carlos Oller essentially rediscovers this perceived shortcoming, diagnosing what he calls the ‘the paradoxes of Parry’s analytic implication’ (140, p. 93) in the first-degree fragment of PAI:

$$A \dot{\wedge} \dot{\neg} A \dot{\wedge} B \vDash_{\text{PAI}_{fde}} \dot{\neg} B$$

Deutsch and Oller independently introduced a four-valued logic in order to rectify such perceived pathologies by further weakening Parry’s system.⁴ The system has appeared by a

⁴While the position outlined by Oller against the Parry ‘paradoxes’ is clear, it is also obvious that inferences such as

$$B \vDash_{S_{fde}} B \dot{\vee} \dot{\neg} B$$

are correct modulo S_{fde} , although such inferences appear to run afoul of the spirit of Deutsch and Oller’s complaint.

number of names, *e.g.*, Deutsch calls the system ‘g’ when it is first introduced in (58), ‘ \mathbf{D}_{fde} ’ in (60), and ‘ \mathbf{S}_{fde} ’ (which we ourselves will adopt in the sequel) in (61) while Oller introduces it with identical matrices in as ‘AL’ in (140).

Definition 2.3.4. \mathbf{S}_{fde} is the first-degree logic induced by the matrix

$$\langle \mathcal{V}_{\mathbf{S}_{fde}}, \mathcal{D}_{\mathbf{S}_{fde}}, f_{\mathbf{S}_{fde}}^{\dot{\neg}}, f_{\mathbf{S}_{fde}}^{\wedge}, f_{\mathbf{S}_{fde}}^{\vee} \rangle$$

where $\mathcal{V}_{\mathbf{S}_{fde}} = \{\mathbf{t}, \mathbf{b}, \mathbf{u}, \mathbf{f}\}$ and $\mathcal{D}_{\mathbf{S}_{fde}} = \{\mathbf{t}, \mathbf{b}\}$ and the functions $f_{\mathbf{S}_{fde}}^{\dot{\neg}}, f_{\mathbf{S}_{fde}}^{\wedge}, f_{\mathbf{S}_{fde}}^{\vee}$ are defined by the following matrices:

$f_{\mathbf{S}_{fde}}^{\dot{\neg}}$		$f_{\mathbf{S}_{fde}}^{\wedge}$	\mathbf{t}	\mathbf{b}	\mathbf{u}	\mathbf{f}	$f_{\mathbf{S}_{fde}}^{\vee}$	\mathbf{t}	\mathbf{b}	\mathbf{u}	\mathbf{f}
\mathbf{t}	\mathbf{f}	\mathbf{t}	\mathbf{t}	\mathbf{b}	\mathbf{u}	\mathbf{f}	\mathbf{t}	\mathbf{t}	\mathbf{t}	\mathbf{u}	\mathbf{t}
\mathbf{b}	\mathbf{b}	\mathbf{b}	\mathbf{b}	\mathbf{b}	\mathbf{u}	\mathbf{f}	\mathbf{b}	\mathbf{t}	\mathbf{b}	\mathbf{u}	\mathbf{b}
\mathbf{u}	\mathbf{u}	\mathbf{u}	\mathbf{u}	\mathbf{u}	\mathbf{u}	\mathbf{u}	\mathbf{u}	\mathbf{u}	\mathbf{u}	\mathbf{u}	\mathbf{u}
\mathbf{f}	\mathbf{t}	\mathbf{f}	\mathbf{f}	\mathbf{f}	\mathbf{u}	\mathbf{f}	\mathbf{f}	\mathbf{t}	\mathbf{b}	\mathbf{u}	\mathbf{f}

Although the conclusion that \mathbf{S}_{fde} enjoys the \mathbf{PP}^+ is proven in (140), it will be instructive to rehearse our own proof.

Observation 2.3.4. \mathbf{S}_{fde} enjoys the \mathbf{PP}^+

Proof. A brief inspection of the matrices for \mathbf{S}_{fde} will establish that \mathbf{u} is infectious in the sense of Observation 2.2.1, while a glance at $\mathcal{D}_{\mathbf{S}_{fde}}$ shows that \mathbf{u} is not designated.

Moreover, every set of formulae Γ has an \mathbf{S}_{fde} valuation in which all $B \in \Gamma$ take designated values. The map $v' : A \mapsto \mathbf{b}$ for all $A \in \mathbf{At}$ assigns a designated value to all atoms. By inspecting the matrices for \mathbf{S}_{fde} , we can easily observe that this propagates through the language, assigning every formula the value of \mathbf{b} . With the language itself having a model, each of its subsets has a model.

By Observation 2.2.1, this entails that the \mathbf{PP}^+ holds for \mathbf{S}_{fde} . □

That consideration of logics of nonsense played a role in proving that S_{fde} enjoys the PP^+ is no coincidence. S_{fde} is a logic of nonsense; indeed, it is a subsystem of Σ_0 .

Observation 2.3.5. $S_{fde} \subseteq \Sigma_0$

Proof. By examining the matrices appearing in Definitions 2.2.4 and 2.3.4, one may confirm that every Σ_0 valuation is also an S_{fde} valuation. Hence, if Γ entails A modulo S_{fde} the same can be said *a fortiori* for Σ_0 . \square

Recall that a logic is *paraconsistent* if explosion—the inference $A \wedge \neg A \vDash B$ —is not a valid inference in that logic. Also, recall that it was explosion that most clearly prevented Σ_0 from enjoying the PP^+ , because $A \wedge \neg A$ had no models at all. Just as employing connexive principles to eliminate this case generates a containment logic, so, too, does relaxing Σ_0 to a paraconsistent logic yield a containment logic.

A paradigmatic paraconsistent logic is the system LP introduced by Priest in (154).

Definition 2.3.5. LP is the first-degree logic induced by the matrix \mathfrak{M}_{LP} :

$$\langle \mathcal{V}_{LP}, \mathcal{D}_{LP}, f_{LP}^{\neg}, f_{LP}^{\wedge}, f_{LP}^{\vee} \rangle$$

with truth values $\mathcal{V}_{LP} = \{t, b, f\}$ and designated values $\mathcal{D}_{LP} = \{t, b\}$. The truth functions $f_{S_{fde}}^{\neg}, f_{S_{fde}}^{\wedge}, f_{S_{fde}}^{\vee}$ are defined by the following matrices:

f^{\neg}		f^{\wedge}	t	b	f	f^{\vee}	t	b	f
t	f	t	t	b	f	t	t	t	f
b	b	b	b	b	f	b	t	b	b
f	t	f	f	f	f	f	t	b	f

Clearly, S_{fde} is a subsystem of LP, as we may easily prove.

Observation 2.3.6. $S_{fde} \subseteq LP$

Proof. Examining the matrices shows that every LP valuation is an S_{fde} valuation. Hence, if some property holds for all S_{fde} valuations it holds *a fortiori* for all LP valuations as well. Hence, if $\Gamma \models_{S_{fde}} A$ then $\Gamma \models_{LP} A$, *i.e.*, $S_{fde} \subseteq LP$. \square

Corollary 2.3.1. $S_{fde} \subseteq \Sigma_0 \cap LP$

Proof. Immediate from Observations 2.3.5 and 2.3.6. \square

This result is encouraging but, although we come close, we do not enjoy the nice alignment that we found in Observation 2.3.3, notably, there are some inferences both Σ_0 valid and LP valid.

Observation 2.3.7. $S_{fde} \neq \Sigma_0 \cap LP$

Proof. Observe that both $A \dot{\wedge} \dot{\neg} A \models_{\Sigma_0} A \dot{\vee} B$ and $A \dot{\wedge} \dot{\neg} A \models_{LP} A \dot{\vee} B$. In the former case, there is no Σ_0 valuation granting $A \dot{\wedge} \dot{\neg} A$ a designated value and the inference is satisfied vacuously; in the latter cases, that $A \dot{\wedge} \dot{\neg} A$ is designated entails that A is also designated, whence $A \dot{\vee} B$ is designated. Clearly, this inference fails to satisfy the \mathbf{PP}^+ and is thus not a valid S_{fde} inference. \square

What is especially interesting about this is that the inference witnessing the inequality between S_{fde} and $\Sigma_0 \cap LP$ holds in the latter systems for entirely different reasons.⁵

With respect to a first-degree logic L , use the notation $L_{\mathbf{PP}}$ to denote the class of L valid inferences satisfying the \mathbf{PP}^+ , *i.e.*, the system defined by

$$\Gamma \models_{L_{\mathbf{PP}}} A \text{ iff } \Gamma \models_L A \text{ and } \mathbf{At}(A) \subseteq \mathbf{At}[\Gamma]$$

We may think of this as the ‘analytic fragment’ of L . Then we are able to correctly characterize S_{fde} :

⁵We will encounter a similar phenomenon in the sequel when we describe the axiom **Safety** that is a hallmark of the first-degree fragment of R–Mingle.

Observation 2.3.8. $S_{\text{fde}} = \text{LP}_{\text{PP}}$

Proof. For left-to-right, we note that Observations 2.3.5 and 2.3.6 entail that any S_{fde} entailment is valid in LP_{PP} .

For right-to-left, suppose that $\Gamma \vDash_{\text{LP}} A$ and $\mathbf{At}(A) \subseteq \mathbf{At}[\Gamma]$. Note that S_{fde} valuations come in two varieties: those whose restrictions to $\mathbf{At}[\Gamma \cup \{A\}]$ are LP valuations and those that are not, *i.e.*, those in which for some $B \in \mathbf{At}[\Gamma \cup \{A\}]$, $v(B) = \mathbf{n}$. By hypothesis, for all valuations of the former type in which all formulae of Γ are designated, A is likewise designated—this is precisely what $\Gamma \vDash_{\text{LP}} A$ means. With respect to the latter type, by hypothesis, $\mathbf{At}(A) \subseteq \mathbf{At}[\Gamma]$, and hence, some formula $B \in \Gamma$ has a constituent atom valued at \mathbf{n} . By the ‘infectiousness’ of this value, it follows that $v(B) = \mathbf{n}$. Hence, in any such valuation, some $B \in \Gamma$ fails to take a designated value, *i.e.*, the *only* valuations in which all $B \in \Gamma$ take designated values are the LP-like valuations. But we have assumed that in such valuations, A takes a designated value when all formulae in Γ do. \square

These observations will come into play again shortly, as we make a deeper examination of S_{fde} and its role in paraconsistent Parry systems in general.

2.4 The Role of S_{fde} in Paraconsistent Parry Systems

While Johnson’s RC is rather anomalous, playing no role with respect to the broader family of containment logics, the Deutsch-Oller system S_{fde} plays a central role in the structure of paraconsistent Parry systems. To observe this, we offer, with minor notational deviations, the semantics for PAI discovered by Kit Fine in (81). We first define a PAI model:

Definition 2.4.1. *A PAI model is an ordered 5-tuple $\langle W, R, C, \Gamma, V \rangle$ with the following interpretations:*

- W is a non-empty set of points

- R is a transitive, reflexive relation on W
- \mathbf{C} is a set $\{\mathbf{C}_w : w \in W\}$ such that $\mathbf{C}_w = \langle C_w, \circ_w \rangle$ is a lower semilattice for all $w \in W$
- Γ is a set $\{\gamma_w : w \in W\}$ such that γ_w maps each element of \mathbf{At} to an element of \mathbf{C}_w , extended through the language by $\gamma_w(A) = \gamma_w(B_0) \circ_w \dots \circ_w \gamma_w(B_n)$, where each $B_i \in \mathbf{At}(A)$
- V is a pair of functions $\langle V^+, V^- \rangle$ mapping all elements of \mathbf{At} to $\wp(W)$ with the condition that for all $A \in \mathbf{At}$, $V^+(A)$ and $V^-(A)$ are pairwise disjoint and exhaust W

The elements of W may retain the usual interpretation of possible worlds while the intended interpretation of the elements of a set C_w are the ‘concepts’ that occur at world w .

Define $a \leq_w b$ as $a \circ_w b = b$. Then we may describe a pair of forcing relations, defined and interpreted as follows:

Definition 2.4.2. *In a PAI model, the positive relation \Vdash^+ can be thought of as holding when a formula is true at a point:*

- $w \Vdash^+ A$ iff $w \in V^+(A)$ for $A \in \mathbf{At}$
- $w \Vdash^+ \neg A$ iff $w \Vdash^- A$
- $w \Vdash^+ B \wedge C$ iff $w \Vdash^+ B$ and $w \Vdash^+ C$
- $w \Vdash^+ B \vee C$ iff $w \Vdash^+ B$ or $w \Vdash^+ C$
- $w \Vdash^+ B \rightarrow C$ iff $\begin{cases} \forall u \text{ such that } wRu, \gamma_u(C) \leq_u \gamma_u(B), \text{ and} \\ \forall u \text{ such that } wRu \text{ and } u \Vdash^+ B, u \Vdash^+ C \end{cases}$

Similarly, the negative relation \Vdash^- may be read as holding when a formula is false at some point:

- $w \Vdash^- A$ iff $w \in V^-(A)$ for $A \in \mathbf{At}$
- $w \Vdash^- \neg A$ iff $w \Vdash^+ A$
- $w \Vdash^- B \dot{\wedge} C$ iff $w \Vdash^- B$ or $w \Vdash^- C$
- $w \Vdash^- B \dot{\vee} C$ iff $w \Vdash^- B$ and $w \Vdash^- C$
- $w \Vdash^- B \rightarrow C$ iff $\begin{cases} w \not\Vdash^+ B \rightarrow C, \text{ or} \\ w \Vdash^+ B \text{ and } w \Vdash^- C \end{cases}$

The notation employed here is inspired by Wansing’s (192) in which a pair of forcing relations—one positive, one negative—is defined. Also note that a deeper analogy with Wansing’s logics I_jC_k introduced in (192) is available. The conditions are virtually identical to Wansing’s treatment of Nelson’s \mathbf{N} of (135). Wansing observes that there isn’t necessarily a privileged interpretation of the *falsity* condition of an implicational formula and offers four distinct approaches to evaluating falsity of a conditional at a point or possible world.⁶ Just as Nelson’s logic of constructible falsity admits such variations, we could just as easily give the same treatment to Deutsch’s \mathbf{S} by selecting alternative falsity conditions for the conditional.

We say that a formula is true in a model— $\mathfrak{M} \models A$ —if for all points w in that model, $\mathfrak{M}, w \Vdash A$.

Definition 2.4.3. *PAI validity*

$\Gamma \models_{\text{PAI}} A$ if for every PAI model \mathfrak{M} if for all $B \in \Gamma$, $\mathfrak{M} \models B$ then $\mathfrak{M} \models A$

An interesting observation is that the first-degree fragment of PAI is effervescent, popping up repeatedly in the literature. The first-degree fragment has been independently discovered by no fewer than four authors. In addition to Parry himself, the system was described by

⁶Also see (74) and (80) for more discussion on the theme of falsity conditions for conditionals.

Zinov'ev as the system S_1 in (202), as Parks-Clifford's first-degree Z in (141), and was also labeled **NDR** in (117) when rediscovered by Frederick Johnson.

An important relationship holds between **PAI**, S_1 , and the classical propositional calculus **CL**. In regard to a logic L defined over a language including an intensional conditional connective \rightarrow , let L_{fde} denote the first-degree fragment of L , *i.e.*, for a finite, non-empty set of formulae Γ and formula A with no appearances of \rightarrow , $\Gamma \vDash_{L_{\text{fde}}} A$ *iff* $\vDash_L \bigwedge \Gamma \rightarrow A$.

Observation 2.4.1. $\Gamma \vDash_{S_1} A$ *iff* $\Gamma \vDash_{\text{CL}} A$ and $\mathbf{At}(A) \subseteq \mathbf{At}[\Gamma]$

Proof. That $S_1 = \text{CL}_{\text{PP}}$ is well established; the reader is referred to proofs in (202) or (117). □

The correspondence between S_1 and PAI_{fde} has been asserted on several occasions. With respect to Zinov'ev's work, that $S_1 = \text{PAI}_{\text{fde}}$ has been observed in (166) (in which S_1 is called 'ZV') while Parry asserts in (145) that PAI_{fde} is characterized by the equivalent bipartite condition. In neither case is this assertion proven, however, so it is prudent to provide proof here.

Observation 2.4.2. S_1 is the first-degree fragment of Parry's **PAI**, *i.e.*, $A \vDash_{S_1} B$ *iff* $\vDash_{\text{PAI}} A \rightarrow B$

Proof. By Observation 2.4.2, we are free to equate S_1 with CL_{PP} ; that $\text{PAI}_{\text{fde}} = \text{CL}_{\text{PP}}$ can be easily seen by considering an arbitrary **PAI** model and a point in that model. For left-to-right, consider a first-degree entailment $A \rightarrow B$, where A and B are zeroth-degree formulae; if $A \rightarrow B$ is a theorem of **PAI** then, as a subsystem of **CL**, it is a theorem of **CL**. That **PAI** obeys the PP^{\rightarrow} entails that $\mathbf{At}(B) \subseteq \mathbf{At}(A)$.

For right-to-left, as **CL** is the 'internal' logic of every point w , that $w \Vdash A$ entails that $w \Vdash B$. Moreover, as $\mathbf{At}(B) \subseteq \mathbf{At}(A)$, $\gamma_w(B) \leq_w \gamma_w(A)$ for any point w . Hence, at any point w' , $w' \Vdash A \rightarrow B$. □

In Section 2.3.2, we referred to a critique of PAI shared by both Deutsch and Oller. We have seen how Oller responded; Deutsch, influenced by the semantical picture laid out by Fine in (81), detailed three fully intensional (*i.e.*, higher degree) systems of paraconsistent containment logic, S , S' , and S'' over the course of several papers: (59), (61), and (62).

In the above semantics for PAI, there was a qualification on the functions V^+ and V^- that for any atom A , $V^+(A) \cap V^-(A) \neq \emptyset$ and $V^+(A) \cup V^-(A) = W$. Relaxing this requirement would permit either an atom to be simultaneously true and false at a point or to be neither true nor false at a point, *i.e.*, would yield a paraconsistent or paracomplete logic. The semantics presented earlier with this restriction relaxed to permit paraconsistency corresponds to Deutsch's S .

Definition 2.4.4. *An S model is defined by rehearsing the conditions from Definition 2.4.1 while relaxing the condition on V^+ and V^- to the weaker clause that*

$$\text{For all } A \in \mathbf{At}, V^+(A) \cup V^-(A) = W$$

Definition 2.4.5. *Validity in S is defined by the following scheme:*

$$\Gamma \models_S A \text{ if for every } S \text{ model } \mathfrak{M} \text{ if for all } B \in \Gamma, \mathfrak{M} \models B \text{ then } \mathfrak{M} \models A.$$

We can make a few further observations concerning the relationship between S_{fde} and other containment logics. In analogy to the fact that $S_1 = \text{CL}_{\text{PP}}$, Observation 2.3.8 shows that $S_{\text{fde}} = \text{LP}_{\text{PP}}$. For one, this enables us to provide a characterization of S_{fde} along the lines of Observation 2.3.3.

Corollary 2.4.1. $S_{\text{fde}} = S_1 \cap \text{LP}$

A further analogy may be made, however, between S_{fde} and Deutsch's S . That S_{fde} is the first-degree fragment of S is reflected by our choice of notation and is asserted by Deutsch in (60) and (61). However, this assertion receives no proof and we thus provide a proof here.

Observation 2.4.3. S_{fde} is the first-degree fragment of Deutsch's S , i.e., $A \models_{S_{\text{fde}}} B$ iff $\models_S A \rightarrow B$

Proof. We recall that in Deutsch's semantics, for each point w , all atoms are given valuations of either $\{\mathbf{t}\}$, $\{\mathbf{f}\}$, or $\{\mathbf{t}, \mathbf{f}\}$. With small changes in notation, for negation, conjunction, and disjunction, Deutsch provides the following:

$$\begin{aligned} (\dot{\neg} \mathbf{t}) \quad & \mathbf{t} \in v_w(\dot{\neg} A) \text{ iff } \mathbf{f} \in v_w(A) \\ (\dot{\neg} \mathbf{f}) \quad & \mathbf{f} \in v_w(\dot{\neg} A) \text{ iff } \mathbf{t} \in v_w(A) \\ (\dot{\wedge} \mathbf{t}) \quad & \mathbf{t} \in v_w(A \dot{\wedge} B) \text{ iff } \mathbf{t} \in v_w(A) \text{ and } \mathbf{t} \in v_w(B) \\ (\dot{\wedge} \mathbf{f}) \quad & \mathbf{f} \in v_w(A \dot{\wedge} B) \text{ iff } \mathbf{f} \in v_w(A) \text{ or } \mathbf{f} \in v_w(B) \\ (\dot{\vee} \mathbf{t}) \quad & \mathbf{t} \in v_w(A \dot{\vee} B) \text{ iff } \mathbf{t} \in v_w(A) \text{ or } \mathbf{t} \in v_w(B) \\ (\dot{\vee} \mathbf{f}) \quad & \mathbf{f} \in v_w(A \dot{\vee} B) \text{ iff } \mathbf{f} \in v_w(A) \text{ and } \mathbf{f} \in v_w(B) \end{aligned}$$

Essentially, that $\mathbf{t} \in v_w(A)$ and that $\mathbf{f} \in v_w(A)$ in Deutsch's original presentation correspond to $w \Vdash^+ A$ and $w \Vdash^- A$, respectively.

Let h be a function equating the values of v_w with LP truth values so that singleton truth values in S are equated with their elements in S_{fde} , i.e.,

$$h(v_w(A)) = \begin{cases} \mathbf{t} & \text{if } v_w(A) = \{\mathbf{t}\} \\ \mathbf{b} & \text{if } v_w(A) = \{\mathbf{t}, \mathbf{f}\} \\ \mathbf{f} & \text{if } v_w(A) = \{\mathbf{f}\} \end{cases}$$

We may note by a simple induction that the 'internal logic' of a point is precisely LP. This is to say that if v_w is a valuation mapping atoms to $\wp(\{\mathbf{t}, \mathbf{f}\})$, then for a first-degree formula, not only is $h \circ v_w$ an LP valuation, but for any zeroth-degree formula B and a truth value \mathbf{v} , $\mathbf{v} \in v_w(B)$ iff $h(v_w(B)) = h(\mathbf{v})$.

Suppose that $\models_S A \rightarrow B$. Then, in every point w in every model, at all points w' such that wRw' , $\gamma_{w'}(B) \leq_{w'} \gamma_{w'}(A)$. Moreover, if A takes a designated value at w' , i.e., $\mathbf{t} \in v_{w'}(A)$, then B takes a designated value at w' . If at all points in all models does $\gamma_{w'}(B) \leq_{w'} \gamma_{w'}(A)$

then $\mathbf{At}(B) \subseteq \mathbf{At}(A)$. Suppose there is an atom $D \in \mathbf{At}(B)$ not in $\mathbf{At}(A)$; then for some model, one could assign $\gamma_{w'}(D)$ to be an element $d \in \mathbf{C}_{w'}$ such that $\gamma_{w'}(A) \not\leq_{w'} d$, whence $\gamma_{w'}(B) \not\leq_{w'} \gamma_{w'}(A)$. Moreover, if at all points in all models a zeroth-degree formula A entails a zeroth-degree formula B , then whenever $\mathfrak{t} \in v_w(A)$, also $\mathfrak{t} \in v_w(B)$. By the above considerations, however, this is just to say that in every LP valuation in which A is designated, B is designated, *i.e.*, $A \models_{\text{LP}} B$. By Observation 2.3.8, these two observations mean that $A \models_{\mathbf{S}_{\text{fde}}} B$.

On the other hand, if $A \models_{\mathbf{S}_{\text{fde}}} B$ where A and B are zeroth-degree formulae, then at any point w in any model, if $w \Vdash^+ A$ then $w \Vdash^+ B$. Likewise, that $\mathbf{At}(B) \subseteq \mathbf{At}(A)$ entails that at any such point, $\gamma_w(B) \leq_w \gamma_w(A)$, whence $\models_{\mathbf{S}} A \rightarrow B$. \square

Given that Deutsch's system is the natural result of modifying PAI to yield a paraconsistent system, the Deutsch-Oller system plays a central role in the theory of \mathbf{S} . It also provides insight into further means of generating Parry systems. For example, the system $\mathbf{S}_{\text{fde}}^*$ —the **PP**-fragment of \mathbf{E}_{fde} introduced by Priest in (156)—would play a central role in a paraconsistent and paracomplete logic similar to \mathbf{S} .

2.5 Conclusions

As Parry frequently referenced, Kurt Gödel conjectured in (101) that **AI** might enjoy a 'double-barrelled' analysis, *i.e.*, $A \rightarrow B$ is an **AI** theorem *iff*

1. $A \Rightarrow B$ is a theorem in a 'carrier logic' for some connective \Rightarrow , and
2. $\mathbf{At}(B) \subseteq \mathbf{At}(A)$

In providing his semantics for **PAI** in (81), Fine essentially confirms Gödel's conjecture and remarks on the wide variety of logics that can be generated by altering the 'carrier logic,'

e.g., by interpreting \Rightarrow as intuitionistic or relevant implication. (The ‘carrier logic’ in the case of PAI itself is S4.)

We have observed that the same can be said for the Deutsch-Oller system S_{fde} and similar conclusions may be drawn about Johnson’s RC and Deutsch’s S. Does this suggest that, as Sylvan suggests in (166), containment logics are merely a syntactic gimmick?

If anything, the opposite conclusion should be drawn from the structure of RC and S_{fde} . Rather than resting, as Sylvan suggested, ‘on a narrow and arbitrary assumption as to what counts as a concept’ (166, p. 101), aligning containment logics with logics of nonsense provides an alternative foundation. That an isomorphism exists between concepts and atomic formulae is not necessary; merely making the claim that meaningfulness must be established in order to ensure the validity of an inference already starts one down the path towards Parry systems.

Moreover, however syntactical the flavor of the **PP** may be, this does not entail that Parry calculi deal in gimmickry. The **VSP**—an equally syntactical criterion—is, after all, a *symptom* of relevance rather than its *explication*. That the **PP** is suggested by a number of distinct and relatively natural positions on inference demonstrates that the Proscriptive Principle may emerge without overt appeal to syntax.

In the coming two chapters, we are going to examine two distinct contexts in which this relationship between nonsense and containment is apparent. In Chapter 3, we will examine Kit Fine’s analysis of Richard Angell’s containment logic AC in which nonsense will correspond to the absence of any truthmaker *or* falsemaker for a sentence at a world. In Chapter 4, we will consider containment logics through the lens of computation, in which nonsense will correspond to the failure of a procedure to terminate its computation.

Chapter 3

Metaphysical Considerations on State Space Semantics

In this chapter, we review elements of Kit Fine’s project of *truth maker semantics*, in which models are constructed on spaces of *states*—fine-grained semantical devices that can stand in for many objects, such as facts, truthmakers, situations, and so forth. Fine’s framework has rapidly borne fruit, providing very natural semantics for many logics and providing elegant solutions to many thorny semantical problems. Fine’s state spaces may be counted as a member of a tradition of fine-grained, objectual approaches to semantics including the distinct fact-based semantics of Bas van Fraassen and Roman Suszko and the situation semantics of Jon Barwise and John Perry. More recent examples of this lineage are found in Greg Restall’s own truthmaker semantics and Fabrice Correia’s version of Fine’s semantics. Restall and Correia both suggest that intuitions concerning facts and their relationship with propositions lead to justifications for various consequence relations (or consequence-like relations), although the two projects each have some unusual features when truthmaking is considered from a metaphysical perspective. Although Fine has cautioned against placing too much metaphysical weight on state space semantics, this chapter suggests that recasting

Restall and Correia’s work in the setting of Fine’s truthmaker semantics provides insight into the metaphysical presuppositions and commitments of these projects.

3.1 State Space Semantics

3.1.1 Facts and Their ‘Philosophical Entourage’

We can consider state-space semantics as a descendant of the semantical analyses of consequence modeled on states that sprung up in the 1960s. It will thus be useful to examine the more fine-grained analyses of entailment made possible by appeal to proper parts of worlds more generally. The interpretation of the central objects of such models, *i.e.*, ‘facts and their philosophical entourage’ (189, p. 477) in van Fraassen’s words, vary; we will use words like ‘states of affairs,’ ‘facts,’ ‘situations,’ and ‘truthmakers’ interchangeably.

Intuitively, moving from worlds to parts of worlds is semantically liberating. Refusing to consider *parts* of the world as playing a semantical role restricts the richness of the theory and leads to counterintuitive consequences that might be thought of as pathologies. Just as the coarse-grained apparatus of possible worlds (without their parts) forces us into the paradoxes of strict implication, when worlds are taken to be the most fine-grained semantical device available, the semantics leads us towards other paradoxes of relevance in the truthmaker case. For example, truthmaker maximalism—which is such a coarse-grained theory—pushes us towards the thesis that tautologies count all facts as truthmakers, a feature that Restall (159) considers one of the ‘darker properties’ (159, p. 333) of the implicit theory of truthmaking underlying classical semantics.

While Armstrong (17) points to Aristotle’s *Categories* as an early example of appeal to truthmakers in the world, these types of objects briefly flourished in the early 20th Century, although always in an informal and inchoate fashion. Mulligan, Simons, and Smith capture

some of this prehistory:

Some thinkers however, such as Russell, Wittgenstein in the *Tractatus*, and Husserl in the *Logische Untersuchungen*, argued that instead of, or in addition to, truth-bearers, one must assume the existence of certain entities in virtue of which sentences and/or propositions are true. Various names were used for these entities, notably ‘fact’, ‘Sachverhalt’, and ‘state of affairs’.(134, p. 287)

Despite the frequency of appeals to facts and other truthmakers in the 1930s, the accounts remained informal for the most part and fell out of vogue until, as van Fraassen describes,

the prevalent opinion seems to be that facts belong solely to the prehistory of semantics and either have no important use or are irredeemably metaphysical or both.(189, p. 477)

In the late 1960s, two projects independently emerged that provided interesting models that demonstrated the power and legitimacy of appeal to facts in the work of Roman Suszko initiated in (182) and the work of van Fraassen in (189).¹

Suszko’s (182) (further developed in collaborations with Stephen Bloom (29) and (30)) and van Fraassen’s (189) provide roughly contemporary *semantical* accounts in which atomic facts or situations are taken to be primitive. Both take the representation of facts endorsed by, *e.g.*, Wittgenstein and Russell, as a starting point and consider how theories of facts influence theories of entailment. As an illustration of the notion of fact to which Suszko and van Fraassen appeal, consider one of the quintessential remarks concerning this philosophical entourage in Bertrand Russell’s *Lectures on Logical Atomism*:

¹It would not be unreasonable to include the contemporary work of Richard Sylvan and Val Plumwood in (168) within this group. However, Sylvan and Plumwood’s interpretation of the novel semantical invention of (168)—the *set-up*—bears more of a likeness to possible worlds than their parts.

When I speak of a fact—I do not propose to attempt an exact definition, but an explanation, so that you will know what I am talking about—I mean the kind of thing that makes a proposition true or false. If I say ‘It is raining’, what I say is true in a certain condition of weather and is false in other conditions of weather. The condition of weather that makes my statement true (or false as the case may be), is what I should call a ‘fact’.(169, pp. 500–501)

Working in a first-order language, both Suszko and van Fraassen describe facts in terms of *complexes* with respect to a domain M , *i.e.*, tuples $\langle R, a_0, \dots, a_{n-1} \rangle$ where R is an n -ary relation on M and $a_0, \dots, a_{n-1} \in M$. In van Fraassen’s case,

[t]he representation of the complex *that-aRb* may now conveniently be achieved by identifying it with the triple $\langle R, a, b \rangle$. (189, p. 482)

An important feature in both accounts is that these primitive complexes are inherently *signed*. In Suszko’s formalism, for each primitive complex $\langle R, a_0, \dots, a_{n-1}, + \rangle$ there exists a primitive complex $\langle R, a_0, \dots, a_{n-1}, - \rangle$ corresponding to the *negation* of *that-aRb*; in (189), this is represented as $\langle \bar{R}, a_0, \dots, a_{n-1} \rangle$. This type of representation has carried forward to the present day. In, *e.g.*, (51), such primitives are interpreted as ‘the obtaining of certain atomic states of affairs and the *nonobtaining* of certain atomic states of affairs.’(51, p. 2)

There are subtleties with respect to the way in which this interpretation departs from Russell. For one, while the terms ‘fact’ or ‘truthmaker’ are typically taken to indicate veridicality, this is not in general required. Although it indeed seems reasonable to suggest that the *existence* of a truthmaker for a statement A entails the truth of A , it is equally reasonable to think that there are things—possibly mere fictions—that *would* have made a statement true had they obtained.

Furthermore, on the Russellian account, when a complex $\langle R, a, b \rangle$ *fails to hold*, (*i.e.*, $\langle a, b \rangle \notin R$), the literal $\neg Rab$ is made true by the *absence* of the tuple $\langle a, b \rangle$ from the

interpretation of R , *i.e.*, $\neg Rab$ is made true by a negative fact in a very literal sense. Suszko and van Fraassen and their inheritors, however, generally allow that there is a robust truthmaker corresponding to $\neg Rab$, which is, of course, the complex $\langle \bar{R}, a, b \rangle$.

There are good reasons for accepting that falsemakers are primitive, that is, on an ontological par with truthmakers. In the theory of truthmaking, for example, that a truthmaker fails to make true a statement A should hardly entail that it is a falsemaker for A . Furthermore, there exist problems with respect to our ability to apprehend negative truths should we deny the existence of atomic falsemakers. In (165), Jay Rosenberg details such a problem:

if the falsity of an atomic proposition consists in its failure to correspond to any atomic fact, it may seem as if, in order to discover that a given atomic proposition was false, we should have to compare it one by one with each atomic fact, noting in each case that it fails to correspond. And this, of course, is an absurd supposition. (165, p. 36)

This last assertion doesn't seem quite true. One could suggest, for example, that the falsity of a proposition φ consists in a *demonstration* that there can be no truthmaker for φ , then one could arguably falsify atomic propositions without being forced to survey all possible truthmakers for the statement. All one would need would be a method of showing that the supposition that a truthmaker for φ exists leads to absurdity.

This is, of course, to equate falsity with intuitionistic negation, which suggests an interesting parallel in the work of Nelson (*e.g.*, (135), (137)) concerning the distinction between intuitionistic and constructible or strong negation. Intuitionist negation asserts that any demonstration of some proposition could be converted into a demonstration of absurdity; the analogous interpretation in terms of truthmakers, would be that the existence of a truthmaker for a statement φ is absurd. Nelson in (135) and (136) suggests that such an account of falsity is inadequate in a number of ways and promotes a constructible negation assert-

ing the existence of what is essentially a constructible falsemaker for a formula φ . This distinction is illustrated well in the discussion of falsification in Heinrich Wansing’s (194). Wansing cites the example of (102) and suggests that a yellow lemon falsifies the statement ‘the lemon is red’ just as directly as it verifies the statement ‘the lemon is yellow.’ We will assume that theories of truthmaking also must provide accounts of falsemaking and that theories of verification also must provide theories of falsification.

3.1.2 Fine’s Truthmaker Semantics

Fine’s state space semantics, like the frameworks of Suszko, van Fraassen, and Barwise and Perry, allow a more fine-grained verification relation between statements and things in virtue of which they are true than is available when coarser objects such as possible worlds are taken to be primitive objects.² For example, given the logical equivalence between formulae A and $A \dot{\vee} (A \dot{\wedge} B)$, it is reasonable to expect that the formulae are true at precisely the same worlds. However, although there is a sense in which statements are *true in virtue of* worlds, this intuition doesn’t *exhaust* the underlying story. After all, we may be reluctant to suggest that A and $A \dot{\vee} (A \dot{\wedge} B)$ are true in virtue of precisely the same facts.

Fine describes this additional richness afforded by state space semantics in the following terms:

For consider a disjunction of the form $A \dot{\vee} (A \dot{\wedge} B)$, say ‘it is rainy or rainy and windy’ and compare it with its first disjunct A (‘it is rainy’). The exact verifiers of the disjunction are the presence of rain and the presence of rain and wind. But the exact verifier for the disjunct A is simply the presence of rain.

Thus within the exact semantics, there is a semantical distinction between A and

²See (149) and (180) for a discussion of how fine-grained an analysis is possible from semantics using possible worlds.

$A \dot{\vee} (A \wedge B)$ ³ while, within the inexact semantics, there is no such distinction; the verifiers of either statement will be the same, viz. those states that involve the presence of rain.(86, p. 4)

Moreover, Fine has assembled a host of topics concerning the semantical evaluation of statements that encounter problems when evaluated against the backdrop of coarse devices like possible worlds, including counterintuitive features of possible-worlds evaluations of scalar implicature, of the logic and meaning of imperatives, and of counterfactuals. In work such as (83), Fine shows that these problems evaporate when one appeals to the additional expressiveness of state space semantics. In particular—and relevant to the matter of Parry’s **PP**—state space semantics allow a very elegant way to model the subject-matter of a proposition.

To examine Fine’s truthmaker semantics, we will first describe the formalism. The primary structure that underlies the models we will employ is a *state space*:

Definition 3.1.1. A state space is a pair $\langle S, \sqsubseteq \rangle$ where S is a nonempty set of states and

- \sqsubseteq is a partial ordering on S
- Every subset of S has a least upper bound with respect to \sqsubseteq

This is to say that $\langle S, \sqsubseteq \rangle$ is an *up-complete poset*. The intended reading of \sqsubseteq is a parthood relation so that for states s, t , $s \sqsubseteq t$ is read as ‘ s is a part of t .’

Furthermore, since least upper bounds are guaranteed to exist, in any state space we can define a binary operation \sqcup on states $s, t \in S$ as the least upper bound of s and t under \sqsubseteq . This is read as the fusion of states s and t . We can extend this definition to fusion over arbitrary *sets* of states so that for a set $T \subseteq S$, $\bigsqcup T$ is defined as the least upper bound of all elements of T . By completeness of any state space, we are guaranteed that a state space

³*N.b.* that this presupposes that A and B are distinct.

S counts as members the fusion \blacksquare of all states in S as well as the fusion \square of the empty set (the ‘null state’).

For many purposes, such as providing accounts of the equivalence of propositions, this structure may suffice, providing all the structure required, for example, in Correia’s state space semantics of (51). But for some purposes, some additional structure is necessary; in (85), Fine considers a notion of possibility, codified by the addition of a subset $S^\diamond \subseteq S$ interpreted as *possible states*, that is, those states that *could* obtain in a world.

Definition 3.1.2. A modalized state space $\langle S, S^\diamond, \sqsubseteq \rangle$ is a triple where $\langle S, \sqsubseteq \rangle$ is a state space and $S^\diamond \subseteq S$ is a nonempty set such that

$$\text{If } s \in S^\diamond \text{ and } t \sqsubseteq s, \text{ then } t \in S^\diamond$$

We can consider some further definitions concerning states in a modalized state space:

Definition 3.1.3. A state s is consistent if $s \in S^\diamond$ and inconsistent otherwise.

Definition 3.1.4. States s, t are compatible if $s \sqcup t \in S^\diamond$ and incompatible otherwise.

Note that consistency, compatibility, and their contrary properties are not defined in terms of valuations but are determined pre-linguistically, that is, in virtue of the structure $\langle S, S^\diamond, \sqsubseteq \rangle$.⁴

We also are interested in *subsets* of S and extend the relation \sqsubseteq in the following way:

Definition 3.1.5. Let $T, U \subseteq S$. Then:

- $T \sqsupseteq U$ —read ‘ T subsumes U ’—if for all states $t \in T$, there exists a state $u \in U$ such that $u \sqsubseteq t$

⁴The appearance of notions of compatibility and incompatibility is especially interesting due to the role of these notions in the development of modal logic. In early presentations of Lewis’ systems of strict implication, entailment ‘ \supset ’ is not primitive, but is defined in terms of the primitive, binary compatibility or co-consistency connective ‘ \circ .’ Lewis goes so far as to refer to the Survey System as the ‘Calculus of Consistencies’ in (126).

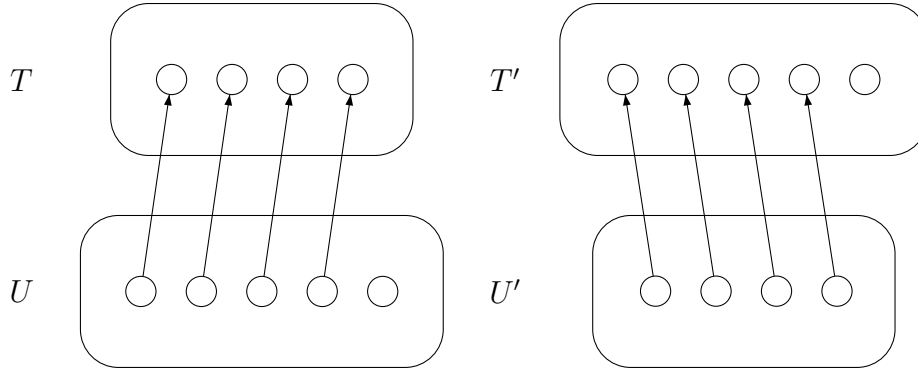
Figure 3.1: $T \sqsupseteq U$ and $U' \sqsubseteq T'$

- $U \sqsubseteq T$ —read ‘ U subserves T ’—is defined as the property that for all states $u \in U$ there exists a $t \in T$ such that $u \sqsubseteq t$

Fine provides the ‘pictorial’ interpretation by the analogy that explicates containment as the condition that ‘each member of T will look down at a member of U and each member of U will look up at a member of T .’ (87, p. 9) Note that the two relations are not necessarily inverses of one another, as is implicit in the illustration of these relations in Figure 3.1.

From these two definitions, Fine provides a further notion of *containment*:

Definition 3.1.6. For $T, U \subseteq S$, T contains U ($T > U$) if $\begin{cases} T \sqsupseteq U, \text{ and} \\ U \sqsubseteq T \end{cases}$

Combining the semantic features of a number of models built off of state spaces (in (51), (82), (87)), we arrive at the following definition of a model:

Definition 3.1.7. A strong modalized state space model is a tuple $\langle S, S^\diamond, \sqsubseteq, |\cdot|^+, |\cdot|^- \rangle$ where $\langle S, S^\diamond, \sqsubseteq \rangle$ is a modalized state space and valuations $|\cdot|^+$ and $|\cdot|^-$ are functions mapping atoms to nonempty subsets of S such that the following properties hold:

- *Semi-Regularity*: $|p|^+$ and $|p|^-$ are complete, i.e., $\sqcup |p|^+ \in |p|^+$

- *Exclusivity*: for all $s \in |p|^+$ and $t \in |p|^-$, $s \sqcup t \notin S^\diamond$
- *Exhaustivity*: for all $s \in S^\diamond$, either there exists $t \in |p|^+$ such that $s \sqcup t \in S^\diamond$ or there exists a $t' \in |p|^-$ such that $s \sqcup t' \in S^\diamond$

$|p|^+$ and $|p|^-$ are interpreted as the sets of *exact verifiers* and *exact falsifiers* of p , respectively.

Note that the requirement of Semi-Regularity is not assumed by Fine in, *e.g.*, (87).⁵ The assumption, however, makes the models easier to work with while not impacting any of the deductive systems defined in terms of state-space semantics. With respect to the properties of Exclusivity and Exhaustivity, Fine offers the following interpretation:

The first constraint rules out there being too many falsifiers for a given set of verifiers and corresponds to the principle that no proposition should be both true and false; and the second rules out there being too few falsifiers for a given set of verifiers and corresponds to the principle that every proposition should be [either] true or false. (85, p. 5)

In (87), distinct verification conditions are provided—an *exact* verification in the style of (189) and an *inclusive* verification. However, given completeness of valuations (*i.e.*, Semi-Regularity), the two types of verification coincide. Hence, we will provide the inclusive variety:

Definition 3.1.8. *The exact verification and falsification conditions between states and formulae are recursively described as:*

- $s \Vdash^+ p$ if $s \in |p|^+$
- $s \Vdash^- p$ if $s \in |p|^-$

⁵*N.b.* that the canonical model Fine gives in (87) is a term model with \sqsubseteq construed as set inclusion. Hence, valuations in the canonical model are complete and Semi-Regularity can be assumed without loss of generality. We sacrifice a modest amount of the flexibility of Fine's models, but nothing upon which anything in the sequel turns.

- $s \Vdash^+ \dot{\neg} A$ if $s \Vdash^- A$
- $s \Vdash^- \dot{\neg} A$ if $s \Vdash^+ A$
- $s \Vdash^+ A \dot{\wedge} B$ if there exist $t, u \in \mathbf{S}$ such that $t \Vdash^+ A$, $u \Vdash^+ B$, and $t \sqcup u = s$
- $s \Vdash^- A \dot{\wedge} B$ if $s \Vdash^- A$, $s \Vdash^- B$, or there exist $t, u \in \mathbf{S}$ such that $t \Vdash^- A$, $u \Vdash^- B$, and $t \sqcup u = s$
- $s \Vdash^+ A \dot{\vee} B$ if $s \Vdash^+ A$, $s \Vdash^+ B$, or there exist $t, u \in \mathbf{S}$ such that $t \Vdash^+ A$, $u \Vdash^+ B$, and $t \sqcup u = s$
- $s \Vdash^- A \dot{\vee} B$ if there exist $t, u \in \mathbf{S}$ such that $t \Vdash^- A$, $u \Vdash^- B$, and $t \sqcup u = s$

From these conditions, Fine provides definitions for several distinct notions of content.

Definition 3.1.9. *The set $\lceil A \rceil^+$ of exact verifiers of A or its complete content is the set*

$$\{s \in S \mid \text{there is an } s' \sqsubseteq s \text{ such that } s' \Vdash^+ A\}^6$$

Likewise, the set $\lceil S \rceil^-$ of exact falsifiers of A is the set

$$\{s \in S \mid \text{there is an } s' \sqsubseteq s \text{ such that } s' \Vdash^- A\}$$

Fine is especially interested in a notion of subject-matter. The subject-matter of A might be reasonably construed as those states—whether states in a world or not—that A is *about*. Because $\lceil A \rceil^+$ is complete, its fusion $\sqcup(\lceil A \rceil^+) \in \lceil A \rceil^+$ and thus may be taken to be a state from which the information in $\lceil A \rceil^+$ may be recovered. Given the relevance that holds between a proposition and its possible verifiers, the maximal verifier is the fusion of all states that A is *about* and is a natural contender for the role of the subject-matter of a sentence. Fine suggests that we take this state to represent the subject-matter of A .

⁶Fine also defines a notion of content $|A|$ as the set of exact verifiers without the constraint that $|A|$ is complete. As we are considering complete valuations, however, completeness will be inherited by the content-sets of complex formulae and the definitions will coincide, that is, for any A , $|A| = \lceil A \rceil$ in any model.

Definition 3.1.10. The positive and negative subject-matters $\sigma^+(A)$ and $\sigma^-(A)$ of A are defined as $\sqcup([A])$ and $\sqcup([\neg A])$, respectively, i.e., the maximal verifier and the maximal falsifier of A .

The elegance of identifying the maximal verifier of A with its subject matter is apparent in many properties of the semantics.

The appropriateness is especially exhibited by Fine's definition of the *replete content* of a statement as the *convex closure* of $\lceil A \rceil^+$.

Definition 3.1.11. The convex closure T_* of a set $T \subseteq S$ is defined as

$$\{s \in S \mid \text{there exist } t, t' \in T \text{ such that } t \sqsubseteq s \sqsubseteq t'\}.$$

Definition 3.1.12. The set $[A]^+$ —the replete content of A —is $\lceil A \rceil_*^+$, i.e., the convex closure of the complete content of A .

It is interesting to note that Fine's account of subject-matter is subtly encoded within the notion of replete content. An alternative definition for the replete content could have explicitly invoked the subject-matter of a statement A , i.e., $\sigma^+(A)$, as illustrated in the following:

Theorem 3.1.1 (Fine). $[A]^+ = \{s \in S \mid \text{there exist } t \in \lceil A \rceil \text{ such that } t \sqsubseteq s \sqsubseteq \sigma^+(A)\}$

I.e., the replete content of A is the *span* of its set of exact verifiers and its subject matter.

This is an especially interesting result when described in the following terms:

Thus the verifiers of A [in its replete content] are those states 'big' enough to contain an exact verifier but 'small' enough to be included within the subject-matter of the statement. They conform to what might be called the 'Goldilocks' Principle', according to which a state s counts as a verifier if it is neither too small (i.e., $s \sqsupseteq t$ [for] some $t \in \lceil A \rceil$) nor too large (i.e., $s \sqsubseteq \sqcup(\lceil A \rceil)$). (87, p. 12)

3.1.3 Validity and Consequence: Two Systems

Given the notion of content defined by Fine, there are a number of ways that the concept of *entailment* could be construed. While it seems plausible to suggest that entailment requires the containment of content from premise to conclusion, it seems equally natural to suggest that entailment holds when all verifiers of a premise verify the conclusion. Fine’s models are flexible enough to accommodate many of these intuitions and, as we might expect, different consequence relations emerge as a result. Two such systems are Richard Angell’s logic of analytic containment **AC** and the Belnap-Dunn logic of \mathbf{E}_{fde} .

Various understandings of entailment defined within Fine’s state space semantics as described by Fine in (87) gives rise to the deductive system **AC** of (9) and (11). Correia—who described the first semantics for **AC** in (49)—had argued in (50) that **AC** indeed gave an appropriate characterization of factual equivalence.

The deductive system of *analytic containment* introduced by Richard Angell in (9) and examined anew in (11) was intended by Angell to characterize a notion of *synonymity*. Angell interpreted **AC** so that the property that A and B are consequences of one another in **AC** is intended to provide an adequate analysis of synonymity between A and B .

A number of potential applications for **AC** have been proposed since its introduction. Belnap suggested the use of **AC** in (25) to amend some perceived shortcomings of Nicholas Rescher’s system of hypothetical reasoning of (158). After providing semantics for **AC** in (49), Fabrice Correia argued in (50) that **AC** characterizes a notion of *factual equivalence*, *i.e.*, that A and B are logically equivalent in **AC** precisely when the two describe the same collection of facts. (*N.b.* that in (51), Correia abandoned this view, arguing that a subsystem of **AC** provides the correct account.)

In (11), Angell considers formulae of the form $A \leftrightarrow B$ to be primitive, where $A, B \in \mathcal{L}_{\text{zdf}}$, while Correia considers an equivalent account of **AC** employing formulae of the form $A \rightarrow B$.

Angell himself remarks that $A \rightarrow B$ and $A \dot{\wedge} B \leftrightarrow A$ are equally good characterizations of the notion of analytic containment. In the present account, we aim to hew close to Correia's own presentation and thus consider the language of *first-degree formulae* \mathcal{L}_{fdf} .

Definition 3.1.13. \mathcal{L}_{fdf} is defined so that

$$\mathcal{L}_{\text{fdf}} = \{A \rightarrow B \mid A, B \in \mathcal{L}_{\text{zdf}}\},$$

Now, let us examine the axiomatization of AC as it appears in (49).

Definition 3.1.14. The system AC is defined by the following axioms:

- AC_{1a} $A \rightarrow \dot{\neg} \dot{\neg} A$
- AC_{1b} $\dot{\neg} \dot{\neg} A \rightarrow A$
- AC₂ $A \rightarrow A \dot{\wedge} A$
- AC₃ $A \dot{\wedge} B \rightarrow A$
- AC₄ $A \dot{\vee} B \rightarrow B \dot{\vee} A$
- AC_{5a} $A \dot{\vee} (B \dot{\vee} C) \rightarrow (A \dot{\vee} B) \dot{\vee} C$
- AC_{5b} $(A \dot{\vee} B) \dot{\vee} C \rightarrow A \dot{\vee} (B \dot{\vee} C)$
- AC_{6a} $A \dot{\vee} (B \dot{\wedge} C) \rightarrow (A \dot{\vee} B) \dot{\wedge} (A \dot{\vee} C)$
- AC_{6b} $(A \dot{\vee} B) \dot{\wedge} (A \dot{\vee} C) \rightarrow A \dot{\vee} (B \dot{\wedge} C)$

while the rules of AC are:

- AC₇ From $A \rightarrow B$ and $B \rightarrow A$ infer $\dot{\neg} A \rightarrow \dot{\neg} B$
- AC₈ From $A \rightarrow B$ infer $A \dot{\vee} C \rightarrow B \dot{\vee} C$
- AC₉ From $A \rightarrow B$ and $B \rightarrow C$ infer $A \rightarrow C$

This gives us a standard account of theoremhood in AC.

Definition 3.1.15. We say that a formula $A \rightarrow B \in \mathcal{L}_{\text{fdf}}$ is a theorem of AC when there exists a finite sequence σ of formulae, each of which is either an axiom of AC or an application

of one of the inference rules to an earlier formula or formulae in the sequence such that σ terminates in $A \rightarrow B$.

One of the remarkable results of (87) is the characterization of AC as a natural consequence relation arising in truthmaker semantics. Indeed, Fine regards his work in (87) as a sort of ‘vindication’ (87, p. 2) of Angell’s work. In the context of state space models, Fine provides a semantical relation corresponding to AC entailment, characterized so that:

Observation 3.1.1 (Fine). $A \rightarrow B$ is a theorem of AC iff for every strong state space model, $[A]^+ > [B]^+$, that is, the replete content of A contains the replete content of B .

In plain language, AC entailment holds when every verifier for A contains a verifier for B and every verifier for B is contained within a verifier for A .

Fine also observes that this relation of containment can be decomposed into a bipartite condition:

Observation 3.1.2. [Fine] $[A]^+ > [B]^+$ iff $\left\{ \begin{array}{l} [A]^+ \sqsupseteq [B]^+, \text{ and} \\ \sigma^+(B) \sqsubseteq \sigma^+(A) \end{array} \right.$

It is interesting to note the proximity between Observation 3.1.2 and the explication of containment provided by Yablo in (200), in which we find the following assessment of semantic containment:

A contains B, I propose, if the argument A, therefore B, is both truth-preserving and subject-matter preserving. (200, p. 3)

Yablo’s explication of containment in terms of the containment of *subject-matter* can also be thought of as a containment with respect to *content* or that which a statement is *about*.

The resemblance between these schemata and Sylvan’s so-called ‘double-barrelled analysis’ makes it worthwhile to appraise Fine’s observation by the lights of Sylvan’s criticism

of Parry logics. This charge has some *prima facie* plausibility; the canonical model of (81), for example, identifies ‘concepts’ with atomic formulae, filtering out problematic entailments on the basis of whether certain sentence letters appear in the antecedent and consequent. In (87), however, this double-barrelled analysis falls out so elegantly from the state space semantics—in what Fine acknowledges is ‘an especially pleasing way’ (87, p. 12)—that it is hard to see how a charge of artificiality could possibly be sustained.

Fine’s semantics is rich enough to accomodate other intuitions concerning entailment, including a vindication of van Fraassen’s discussion in (189) of the Belnap-Dunn logic \mathbf{E}_{fde} of tautological entailments. The truth-functional semantics for first-degree system \mathbf{E}_{fde} —so-called because it is the first-degree fragment of the relevant logic \mathbf{E} and is often labeled ‘FDE’—was introduced by Dunn in (66). Belnap’s interpretation of this semantics—outlined in (23) and (24)—will be of special importance in the sequel.

From a proof-theoretic perspective, \mathbf{E}_{fde} may be defined as follows:

Definition 3.1.16. *The system \mathbf{E}_{fde} is defined axiomatically by adding the following axiom to the axiomatic presentation of AC:*

$$\text{FDE}_1 \quad A \rightarrow A \dot{\vee} B$$

A four-valued semantics for \mathbf{E}_{fde} may also be given, described as follows:

Definition 3.1.17. *The logic \mathbf{E}_{fde} is the logic induced by the matrix $\mathfrak{M}_{\mathbf{E}_{fde}}$*

$$\langle \mathcal{V}_{\mathbf{E}_{fde}}, \mathcal{D}_{\mathbf{E}_{fde}}, f_{\mathbf{E}_{fde}}^{\dot{\wedge}}, f_{\mathbf{E}_{fde}}^{\dot{\vee}}, f_{\mathbf{E}_{fde}}^{\dot{\wedge}}, f_{\mathbf{E}_{fde}}^{\dot{\vee}} \rangle$$

where $\mathcal{V}_{\mathbf{E}_{fde}} = \{\mathbf{t}, \mathbf{b}, \mathbf{n}, \mathbf{f}\}$, $\mathcal{D}_{\mathbf{E}_{fde}} = \{\mathbf{t}, \mathbf{b}\}$, and the functions $f_{\mathbf{E}_{fde}}^{\dot{\wedge}}$, $f_{\mathbf{E}_{fde}}^{\dot{\vee}}$, $f_{\mathbf{E}_{fde}}^{\dot{\wedge}}$, $f_{\mathbf{E}_{fde}}^{\dot{\vee}}$ are defined by the following matrices:

$f_{E_{fde}}^{\dot{\leftarrow}}$		$f_{E_{fde}}^{\dot{\leftarrow}}$	t	b	n	f	$f_{E_{fde}}^{\dot{\leftarrow}}$	t	b	n	f
t	f	t	t	b	n	f	t	t	t	t	t
b	b	b	b	b	f	f	b	t	b	t	b
n	n	n	n	f	n	f	n	t	t	n	n
f	t	f	f	f	f	f	f	t	b	n	f

Belnap considers the problem of what occurs when a computer or ‘artificial reasoner’ receives contradictory messages. *E.g.*, a central computer can be set up to receive values from sensors concerning the velocity of a vehicle. Suppose there are two such sensors in the vehicle and that one is malfunctioning so that the computer is being informed by two equally trustworthy sources that the vehicle is moving at two different speeds. Classically, faced with inconsistent data, one has warrant to infer any arbitrary conclusion. But from the standpoint of a relevant logician— E_{fde} is \vdash -relevant—such contradictions should not ‘pollute the data,’ in Belnap’s words.

On this reading, that A is evaluated as **t** is read as ‘I have a source that has told me that A is true.’ When A is evaluated as **f**, this is read as ‘I have a source that has told me that A is not true.’ Naturally, one can be faced with a situation in which both these statements hold, which corresponds to the value **b**, while when one has received no statements regarding A , this is represented by A ’s being evaluated as **n**.

Now, while the most salient interpretation E_{fde} is in terms of computation, E_{fde} and fact-like semantics enjoy a deep and effervescent relationship. Both van Fraassen in (189) and Barwise and Perry in (21) suggest that E_{fde} captures an important and interesting entailment relationship between propositions. It is not surprising, then, that Fine proves in (87) that E_{fde} can be recast in his semantics in a natural way.

Fine defines inexact consequence in the following way:

Definition 3.1.18. *B is an inexact consequence of A if in any state space model, $[A]^+ \sqsubseteq [B]^+$*

It is proven in (87) that E_{fde} corresponds to the logic of inexact consequence.

Theorem 3.1.2 (Fine). *$A \models_{E_{\text{fde}}} B$ if and only if in any state space model, $[A]^+ \sqsupseteq [B]^+$*

3.2 Correia on Factual Equivalence

In (49), Correia studied Angell’s AC in the context of a strong equivalence between facts. Correia defines a notion of factual equivalence so that two sentences A and B are factually equivalent whenever any statement of the form “ s grounds A ” can be replaced by “ s grounds B ” *salva veritate*. In (50), Correia further argued for the suitability of AC as an axiomatization of the logic of factual equivalence.⁷

3.2.1 Correia’s Logic of Factual Equivalence

In (51), Correia rejected his earlier position that AC captured an adequate notion of factual equivalence, arguing that there are equivalent formulae that do not describe precisely the same facts. AC is thus rejected by Correia as *too strong*, compelling Correia to provide a weaker notion of factual equivalence, one that is a subsystem of the equivalential formulation of AC. Correia provides no name for this system, and we will default to the easily recognizable label “Cor.”

Definition 3.2.1. *The system Cor is determined by the following axioms:*

⁷There is a parallel between how models are employed by Fine and Correia and how models are employed by van Fraassen and Suszko. van Fraassen was concerned with providing fine-grained accounts of *entailment* while Suszko was concerned with an appropriate account of *identity*. A similar divide occurs between Fine and Correia: Correia is concerned with the *equivalence* of two formulae in a model while Fine is concerned with representing *consequence* in a model.

- Cor₁ $A \leftrightarrow \dot{\neg} \dot{\neg} A$
 Cor₂ $A \leftrightarrow A \dot{\wedge} A$
 Cor₃ $A \dot{\wedge} B \leftrightarrow B \dot{\wedge} A$
 Cor₄ $A \dot{\wedge} (B \dot{\wedge} C) \leftrightarrow (A \dot{\wedge} B) \dot{\wedge} C$
 Cor₅ $A \leftrightarrow A \dot{\vee} A$
 Cor₆ $A \dot{\vee} B \leftrightarrow B \dot{\vee} A$
 Cor₇ $A \dot{\vee} (B \dot{\vee} C) \leftrightarrow (A \dot{\vee} B) \dot{\vee} C$
 Cor₈ $\dot{\neg}(A \dot{\wedge} B) \leftrightarrow \dot{\neg} A \dot{\vee} \dot{\neg} B$
 Cor₉ $\dot{\neg}(A \dot{\vee} B) \leftrightarrow \dot{\neg} A \dot{\wedge} \dot{\neg} B$
 Cor₁₀ $A \dot{\wedge} (B \dot{\vee} C) \leftrightarrow (A \dot{\wedge} B) \dot{\vee} (A \dot{\wedge} C)$

The rules of Cor are:

- Cor₁₁ From $A \leftrightarrow B$ infer $B \rightarrow A$
 Cor₁₂ From $A \leftrightarrow B$ and $B \leftrightarrow C$ infer $A \leftrightarrow C$
 Cor₁₃ From $A \leftrightarrow B$ infer $A \dot{\wedge} C \rightarrow B \dot{\wedge} C$

From a proof-theoretic perspective, Correia notes that AC may be derived from Cor by the addition of rule AC₇ or by adding the pair of axioms AC_{6a} and AC_{6b}. Furthermore, in Cor we may define a notion of entailment where $A \rightarrow B$ serves as an abbreviation for $A \dot{\wedge} B \leftrightarrow A$. As a subsystem of Angell's AC, the first-degree entailment version of Cor so defined will enjoy the Proscriptive Principle and may be thus considered a Parry logic as well.

In order to provide a semantics for Cor, Correia modifies the strong state space models of (87) by relaxing the condition that valuations be *total*, *i.e.*, Correia assumes only that $|\cdot|^+$ and $|\cdot|^-$ are *partial* functions. Correia calls his modification of Fine's state space semantics "fitting description semantics" as the relation of exact verification $s \Vdash^+ A$ is interpreted by Correia as the property that a situation s is *fittingly described* by A .

Definition 3.2.2. A weak state space model is a tuple $\langle S, \sqsubseteq, |\cdot|^+, |\cdot|^- \rangle$ where $\langle S, \sqsubseteq \rangle$ is a state space and valuations $|\cdot|^+$ and $|\cdot|^-$ are partial functions mapping atoms to complete and

nonempty subsets of S .

In (51), Correia argues that for two statements A, B to be *factually equivalent* is for A and B to fittingly describe precisely the same states in each weak state space model. That two formulae A, B fittingly describe the same states in every model is described as *supervalidity* of the equivalential formula $A \leftrightarrow B$. Equivalently, supervalidity may be defined as the property that the complete content of A is identical to that of B in every weak state space model.

Definition 3.2.3. *A formula $A \leftrightarrow B$ is supervalid if in every weak state space model S , $[A]^+ = [B]^+$*

Soundness and completeness between the axiomatic and semantical presentations of Cor is proven in (51).

Theorem 3.2.1 (Correia). *$A \leftrightarrow B$ is a provable in Cor if and only if $A \leftrightarrow B$ is supervalid.*

Note, of course, that Fine’s strong models are trivially weak models. However, in order to induce the logic Cor , the class of models with respect to which it is complete must be weak. Hence, accepting Cor comes with a semantical commitment as well. If the facts *qua* semantical device are believed to reflect any features of facts *qua* metaphysical object, then Correia’s reliance on weak models bears rather heavy metaphysical commitments as well.

3.2.2 Correia’s Rejection of Distribution

In (51), Correia diverges from Angell because of worries that the relation of factual equivalence “does not validate the distributivity principle according to which $A \dot{\vee} (B \dot{\wedge} C)$ is always equivalent to $(A \dot{\vee} B) \dot{\wedge} (A \dot{\vee} C)$.” (51, p. 2) In both (50) and (51), the importance of a logical account of factual equivalence is motivated by concerns of intersubstitutivity within contexts of *explanation* or *grounding*.

Justifying the rejection of distributivity in AC requires that one provides a case in which some fact grounds a sentence of the form $(A \dot{\vee} B) \dot{\wedge} (A \dot{\vee} C)$ but fails to serve as a ground for $A \dot{\vee} (B \dot{\wedge} C)$. Correia gives the following example to suggest there are instances of these two formulae that are not factually equivalent, *i.e.*, intersubstitutable in contexts of grounding. Correia supposes for the argument that the sentences “Sam is sad” and “Sam is ill” are true and presents the following three sentences:

- 1 The fact that Sam is sad grounds the fact that (Sam is sad or Sam is bad)
- 2 The fact that Sam is ill grounds the fact that (Sam is sad or Sam is ill)
- 3 The facts that Sam is sad and that Sam is ill ground the fact that ((Sam is sad or Sam is bad) and (Sam is sad or Sam is ill)).

Were distributivity to hold, then from 3, we could infer

- 4 The facts that Sam is sad and that Sam is ill ground the fact that (Sam is sad or (Sam is bad and Sam is ill)).

But Correia wants to reject this proposition, and hence, must reject distributivity.

But intuitively [4] is false. For we may suppose that Sam is not bad, in which case ‘Sam is bad and Sam is ill’ will be false, and accordingly the fact that Sam is ill will play no role whatsoever in grounding the disjunctive fact. (The fact that Sam is sad will do the work.)(51, p. 17)

In order to more precisely parse this, let us turn to an example of a weak state space model that witnesses a failure of distribution. For simplicity’s sake, we will not consider the state space to be modalized.

Example 3.2.1. *Let \mathbf{S}_C be defined so that*

- $S = \{s_0, s_1, s_2\}$
- $s_0 \sqsubseteq s_2$ and $s_1 \sqsubseteq s_2$
- $|p|^+ = \{s_0\}$ and $|q|^+ = \{s_1\}$

Given this model, we observe that $s_0 \Vdash^+ p$, whence $s_0 \Vdash^+ p \dot{\vee} r$. Furthermore, because $s_1 \Vdash^+ q$, also $s_1 \Vdash^+ p \dot{\vee} q$. Because $s_2 = s_0 \sqcup s_1$, it follows that $s_2 \Vdash^+ (p \dot{\vee} r) \dot{\wedge} (p \dot{\vee} q)$.

However, $s_2 \not\Vdash^+ p \dot{\vee} (r \dot{\wedge} q)$. Were this to hold, then given the recursive definition, either

1. $s_2 \Vdash^+ p$,
2. $s_2 \Vdash^+ (r \dot{\wedge} q)$, or
3. there exist $t, u \in S$ such that $s_2 = t \sqcup u$, $t \Vdash^+ p$, and $u \Vdash^+ r \dot{\wedge} q$

The first fails to hold by construction of \mathbf{S} . The failure of the second and third conditions illustrates the need for Correia's requirement that $|\cdot|^+$ and $|\cdot|^-$ be partial functions. Both would require that for some $t \sqsubseteq s_2$, $t \Vdash^+ q$.

We note that formalizing Correia's plain language example *required* that the model be *weak* insofar as $|r|^+ = \emptyset$. But, as we noted, this assumption carries semantical baggage, requiring an account of logical space in which it is not *logically possible* that some statement— r in the example—has verifiers or falsifiers. This has the consequence that it is only when certain states of affairs are entirely absent from logical space that Correia's account of factual equivalence holds true.

3.2.3 Hypernonsensicality

Depending on how much interpretive weight we place on the semantics, it is reasonable to find Correia's assumption to be quite metaphysically charged. Correia follows Fine in interpreting state space models as representing the collection of logical space, *i.e.*, the totality of possible

facts. Correia’s weak models essentially allow that some atom p may not have verifiers or falsifiers.

Now, the absence of both verifiers and falsifiers may be reasonable in a number of contexts—in the actual world, if p has a verifier then we *expect* it to lack a falsifier. Indeed, the possibility that a proposition may lack verifiers and falsifiers is reflected in Parry’s suggestion that a god could “create a world in which the proposition p is true, without thereby creating all the objects contained in any other proposition q ,” a crucial element of his motivations for (142). Likewise, in Peter Loftson’s (129) and (130), Loftson develops possible worlds semantics that captures the observation that in a possible world in which an individual a (say that it is denoted by “ \underline{a} ”) does not exist, any Russellian proposition corresponding to a sentence containing the name “ \underline{a} ” will not exist. For example, according to Russell, the structured proposition corresponding to the statement

- Either Barack Obama is president or Barack Obama is not the president.

contains the referent of “Barack Obama” as a part. Hence, the proposition itself will not exist at any world w in which Obama was not born, and the sentence would therefore not be true at w due to the absence of any truth bearer. In such occasions, the position of *e.g.* Bochvar ((31)) or Halldén ((104)) that some statements are *nonsensical* seem rather reasonable.

But S , under Correia and Fine’s readings, is taken to represent *logical space*, and while some statements (*e.g.* “Colorless green ideas sleep furiously.”) may lack verifiers or falsifiers with *metaphysical* necessity, it is another matter entirely that some statements lack verifiers or falsifiers with *logical* necessity, that is, there is no possible assignment of the terms in the sentence to meanings such that the sentence would turn out true. In a sense, Correia’s condition then corresponds to the possibility of a proposition’s being *hypernonsensical*—that not only might a proposition be meaningless at a world but also meaningless *in logical space*.

Our earlier considerations on logics of nonsense provide cases related to grammaticality in which examples of hypernonsensical statements might seem plausible. Åqvist's (1), for example, considers "an important class of meaningless sentences [to be] those that are not well formed in accordance with certain syntactical rules." (1) Certainly, if mere juxtapositions of syncategorematic terms are identified as paradigmatic "nonsensical" statements, Åqvist's example seems to provide a case of "statement" that lacks verifiers and falsifiers in logical space, *e.g.*, it is entirely reasonable to exclude truthmakers for the string "and or and" from logical space. However, as Dawson notes in (57), to identify ill-formed strings of symbols with formulae is to misunderstand Bochvar and Halldén, something reflected in such strings not appearing in the language with which we have so far worked. This sentiment is also reflected in the related work of Leonard Goddard and Richard Sylvan, who, in discussing such systems, 'exclude from consideration both gibberish and garbled word-strings.' (99, p. 42) More problematically for the present case, Correia's example requires an occasion in which a statement lacks verifiers but has possible falsifiers, but Åqvist's example of ill-formed formulae seems to preclude such instances. For example, the string "not-(and or and)" seems as ill-formed as "and or and"; the suggestion that there are no verifiers for an ill-formed string seems to entail that neither are their falsifiers.

A more plausible—albeit analogous—case is found in Carnap's strain of logical positivism (*e.g.*, (39)), in which category mistakes such as "Caesar is a prime number" are considered to be literally nonsensical. Carnap's solution to the problem of category mistakes is to reduce these statements to the category of the ungrammatical. Recall that "Caesar is a prime number" is "just as linguistically incorrect" (39, p. 68) as "Caesar is and" and this pseudo-statement is therefore meaningless with logical necessity. With no possible verifiers in logical space, on Carnap's account, category mistakes are indeed a type of "hypernonsense."

However, although Dawson's worry is perhaps superficially resolved, other problems related to Åqvist's suggestion reappear. If "Caesar is a prime number" is of the same species

as “Caesar is and,” then it is not clear how the sentence could have a possible falsifier while lacking any possible verifiers. More importantly, Correia’s examples—being on their faces well-formed, meaningful sentences—are not of this type, no matter how category mistakes are treated. Correia’s example requires that the sentence “Sam is bad” fittingly describes no state—that is, that the sentence has no verifiers—and “Sam is bad” should hardly be counted as a category mistake, much less ungrammatically so.

A representation of logical space in which a modest statement like “Sam is bad” has no possible verifiers seems to be a questionable representation. That strong state space models *prohibit* the hypernonsensicality of such statements seems to be a mark in their favor, making it reasonable to ask whether the metaphysical intuitions that Correia seeks to model lead inevitably to such scenarios, *i.e.*, whether these intuitions *require* weak state space models. In what follows, we will attempt to dismiss the specter of hypernonsensicality by accommodating Correia’s intuitions concerning distribution *within* the framework of strong state space models.

3.2.4 Factual Equivalence Without Hypernonsense

That the metaphysical stakes are relatively high entails that it is reasonable to ask if this alteration to Fine’s models is indeed necessary, that is, whether Correia’s intuitions about factual equivalence can be accommodated by strong models. In order to examine this, let us introduce the following notation:

Definition 3.2.4. *For a state s and formula A , let $[A] \upharpoonright_s$ —the s -restricted content of A —be defined as $\{t \in S \mid t \sqsubseteq [A] \text{ and } t \sqsubseteq s\}$.*

It can be easily demonstrated that given completeness of valuations, $[A] \upharpoonright_s$ is complete for all s and A .

We can now proceed to provide an alternative semantical account of Cor more harmonious

with the semantics of (87) in that it requires valuations to be total, that is, we can impose the condition of completeness of valuations without impacting the logic itself.

Observation 3.2.1. $A \leftrightarrow B$ is a theorem of **Cor** iff in all strong modalized state space models, for any state $s \in S$, $[A] \upharpoonright_s = [B] \upharpoonright_s$

Proof. For left-to-right, we prove the contrapositive. Given a strong modalized state space model $\langle S, S^\diamond, \sqsubseteq, |\cdot|^+, |\cdot|^-\rangle$, one can construct a weak state space model (not necessarily modalized) $\langle \{t \in S \mid t \sqsubseteq s\}, \sqsubseteq, |\cdot|^+, |\cdot|^-\rangle$ where $|p|^+$ and $|p|^-$ are defined as $[p] \upharpoonright_s$ and $[\neg p] \upharpoonright_s$, respectively. Furthermore, as the verification and falsification conditions at a state t are determined exclusively by states $t' \sqsubseteq t$, the restrictions of the verification and falsification conditions at each $t \sqsubseteq s$ will remain unchanged in the corresponding weak model. Hence, if there is a strong state space model such that there exists an s where $[A] \upharpoonright_s \neq [B] \upharpoonright_s$, we can extract from this a weak model witnessing this. By completeness of Correia's semantics of (51), this entails that $A \leftrightarrow B$ is not a theorem of—is not *supervalid* in—**Cor**.

For right-to-left, we again prove the contrapositive. Suppose that $A \leftrightarrow B$ is not a theorem of **Cor**. Then we note that Correia's completeness proof for **Cor** found in (51) appeals to Fine's canonical model of (87), in which $|p|^+ = \{p\}$ and $|p|^- = \{\neg p\}$. By completeness, in the canonical model $|A| \neq |B|$, whence $|A| \upharpoonright_{\blacksquare} \neq |B| \upharpoonright_{\blacksquare}$. Furthermore, we can follow (85) and define a strong, modalized state space model by defining

$$S^\diamond = \{s \in \wp(\mathbf{Lit}) \mid \text{for all } p \in \mathbf{At} \text{ either } p \notin s \text{ or } \neg p \notin s\}.$$

Hence, the canonical model provides the counterexample we require. □

It follows that the questionable picture of logical space in which there may be atoms with no possible verifiers or falsifiers is not essential to Correia's account of equivalence.

We are thus free to read supervelocity in Cor as the assertion that with respect to any complex state of affairs s , the elements of s verifying A are precisely those that verify B . This seems to be a reasonable characterization; assertions are not made in a vacuum but carry presuppositions—*i.e.*, states against which a proposition is evaluated—no matter how meager these presuppositions may be.

Both AC and Cor can be considered to be containment logics and the state space semantics brings to the fore the sense in which some account of nonsense or meaninglessness plays a role. In particular, a fact-based semantics allowed us to frame—and resolve—related questions with respect to Correia’s preferred account of factual equivalence in (51). Before returning to the matter of nonsense and containment in the context of computation, though, we may briefly consider a further way in which Fine’s state space semantics can aid in the clarification of matters of entailment and truthmaking.

3.3 Restall on Truthmaking

State space semantics may also be employed to shed light on competing fact-like semantics. In a series of papers (159), (161), and (162), Restall has worked to provide a formal, semantical account of truthmaking faithful to the Australian Realist tradition as exemplified by, *e.g.*, the work of Armstrong in (17). In the introduction to (159), Restall cites Frank Jackson as an illustration of the obvious connection between truthmakers and entailment:

If Φ entails Π , what makes Φ true also makes Π true (at least when Φ and Π are contingent). (111, p. 32)

Of particular interest is the following thesis:

Whenever something is true, there must be something whose existence entails *in an appropriate way* that it is true. (26, p. 126)

The models that we will now review are intended to capture this thesis.

3.3.1 Restall's Truthmaker Semantics

Restall's models of (159) are simpler than Fine's state space models but insofar as the two semantics are meant to capture similar intuitions, there is much in common between the two frameworks. For his models, Restall assumes a space S of truthmakers and defines the semantics so that each statement φ is mapped to some set of elements of S —the truthmakers of φ .

Definition 3.3.1. *A Restall model is a 3-tuple $\langle S, \sqsubseteq, |\cdot| \rangle$ where $\langle S, \sqsubseteq \rangle$ is a state space and $|\cdot|$ is a function from **Lit** to $\wp(S)$ such that:*

- *For no s does $s \models p$ and $s \models \neg p$*
- *For all p , there exists a state $s \in S$ such that either $s \models p$ or $s \models \neg p$*

As in the case of state space models, we extend a forcing relation between truthmakers (*i.e.*, states) and complex formulae:

Definition 3.3.2. *In a Restall model, we extend a truthmaking relation \Vdash so that for literals,*

- *$s \Vdash p$ if $s \in |p|$*
- *$s \Vdash \neg p$ if $s \in |\neg p|$*

This is extended to the case of complex positive formulae:

- *$s \Vdash A \wedge B$ iff $s \Vdash A$ and $s \Vdash B$*
- *$s \Vdash A \vee B$ iff $s \Vdash A$ or $s \Vdash B$*

And in negative complex formulae, we appeal to Boolean equivalences:

- $s \Vdash \neg\neg A$ iff $s \Vdash A$
- $s \Vdash \neg(A \wedge B)$ iff $s \Vdash \neg A$ or $s \Vdash \neg B$
- $s \Vdash \neg(A \dot{\vee} B)$ iff $s \Vdash \neg A$ and $s \Vdash \neg B$

Truth in a model is defined as we expect, that is, $\mathbf{M} \models A$ holds when there exists a truthmaker for A .

Definition 3.3.3. *A Restall model \mathbf{M} makes a statement A true— $\mathbf{M} \models A$ —if there exists an $s \in S$ such that $s \Vdash A$.⁸*

Like van Fraassen in (189), Restall has an interest in describing classical consequence in terms of facts or truthmakers, suggesting that more fine-grained models will provide insight into the role that facts/truthmakers play with respect to logical consequence. Having defined truth in a model—where a model \mathbf{M} stands in for a possible world—classical entailment can be recovered as truth preservation at all possible worlds.

Theorem 3.3.1. *(Restall) $A \models_{\text{CL}} B$ is a classically valid inference if at every Restall model \mathbf{M} such that $\mathbf{M} \models A$, also $\mathbf{M} \models B$.*

That classical consequence can be so naturally recast in terms of Restall’s models attests to the flexibility of his semantics.

Now, insofar as a model \mathfrak{M} is identified with a possible world (with S serving to catalog its parts), this account of classical consequence coincides with the interpretation as truth preservation at all possible worlds. Despite the added power of the semantics, construing entailment in this way leads to familiar problems. For example, the familiar paradoxes of strict implication of (126) or (127) appear so that *all* propositions A bear this relationship to the tautology $B \dot{\vee} \neg B$.

⁸While using “ \models ” both as a relation between formulae and as a relation between a model and a formula might be considered an abuse of notation, this is standard in model theory.

It is thus interesting to pursue truthmaker accounts of stronger, more subtle entailment relations between antecedent and consequent than is reflected in the classical account, and Restall offers two competing versions of “real” entailment in (159) that reflect a more robust role played by truthmakers in the inference from A to B . Restall’s first account of truthmaker entailment (or truthmaker entailment in the first sense) imports the familiar notion of strict entailment as preservation of truth across all worlds, *i.e.*, that $A \rightarrow B$ is true if at every world at which A is true, B , too, is true. Restall assigns an analogous role to truthmakers so that $A \rightarrow B$ holds if “every truthmaker for A is a truthmaker for B .” (159, p. 339) More formally, we define

Definition 3.3.4. $A \vDash B$ is a truthmaker entailment in the first sense if at every Restall model \mathbf{M} , for every truthmaker $s \in S$ such that $s \Vdash A$, also $s \Vdash B$.

Restall continues to show that the deductive system corresponding to this first sense of truthmaker entailment is a familiar one. The logic of truthmaker entailment in the first sense corresponds to consequence in the strong Kleene three-valued logic \mathbf{K}_3 , introduced in (122) as an account of classical logic in which valuations may be partial functions.⁹

\mathbf{K}_3 may be defined over the language \mathcal{L}_{zdf} by the following matrix:

Definition 3.3.5. \mathbf{K}_3 is the logic induced by the matrix

$$\langle \mathcal{V}_{\mathbf{K}_3}, \mathcal{D}_{\mathbf{K}_3}, f_{\mathbf{K}_3}^{\dot{\neg}}, f_{\mathbf{K}_3}^{\dot{\wedge}}, f_{\mathbf{K}_3}^{\dot{\vee}} \rangle$$

where $\mathcal{V}_{\mathbf{K}_3} = \{\mathbf{t}, \mathbf{n}, \mathbf{f}\}$ and $\mathcal{D}_{\mathbf{K}_3} = \{\mathbf{t}\}$ and the functions $f_{\mathbf{K}_3}^{\dot{\neg}}, f_{\mathbf{K}_3}^{\dot{\wedge}}, f_{\mathbf{K}_3}^{\dot{\vee}}$ are defined by the following matrices:

⁹Recall that Bochvar’s internal nonsense logic Σ_0 was also introduced by Stephen Kleene in (122) and is thus frequently referred to as Kleene’s “weak” three-valued logic, whence the description of \mathbf{K}_3 as “strong.”

$f_{\mathcal{K}_3}^{\dot{\leftarrow}}$		$f_{\mathcal{K}_3}^{\hat{\leftarrow}}$	t	n	f	$f_{\mathcal{K}_3}^{\dot{\leftarrow}}$	t	n	f
t	f	t	t	n	f	t	t	t	t
n	n	n	n	n	f	n	t	n	n
f	t	f	f	f	f	f	t	n	f

In (159), Restall shows that truthmaker entailment in the first sense and \mathcal{K}_3 consequence coincide, captured by the following theorem:

Theorem 3.3.2. *(Restall) $A \models B$ is a truthmaker entailment in the first sense if and only if $A \models_{\mathcal{K}_3} B$*

While Kleene introduced \mathcal{K}_3 in the context of studying partial functions, its appearance in this context is not altogether surprising. It is worth mentioning that Barwise and Perry’s situation semantics in (20) yields \mathcal{K}_3 consequence as well. Although the later semantics of (21) (like van Fraassen’s factual entailment) yields \mathbf{E}_{fde} , the earlier paper disallows inconsistent situations, a condition that corresponds to the suppression of the truth value **n** and, hence, the collapse of the matrix semantics for \mathbf{E}_{fde} to the matrix semantics for \mathcal{K}_3 .¹⁰

There is a long tradition of using facts not only to define and explain weak consequence relations, but also to shed light on classical logic by recovering classical entailment within some framework of facts or situations. It seems that it is an equally worthy goal to see what light can be shed on Restall’s account by reseating it within the framework of state space semantics.

3.3.2 Worlds, Again

Reviewing Fine’s “classical recapture”—*i.e.*, the account of classical validity in terms of state space models—is worthwhile for two reasons. On the one hand, such a review will provide

¹⁰Precluding inconsistent situations is analogous to removing the “both” value **b** from the semantics for \mathbf{E}_{fde} described in Definition 3.1.17. Removing this value leads to the many-valued semantics for \mathcal{K}_3 in Definition 3.3.5.

us insight into how to bring Fine’s account of CL into harmony with the underlying picture in Restall’s Theorem 3.3.1. On the other hand, examining alternative characterizations of classical logic in state space semantics will allow us to introduce a handful of interesting observations.

Fine’s recovery of classical consequence in (86) is given in terms of verification by states in general. However, an equivalent notion of entailment in sympathy with Restall’s representation of classical consequence may be described as well. But in order to define truth preservation across possible worlds, we have to first define an appropriate representation of a world in state space semantics.

The most intuitive interpretation of states is that they represent states of affairs or facts. If the Tractarian view is that world is an aggregates of states of affairs, then it is clear that state space semantics can support a similar, *combinatorial* notion of possible world. A very prominent example of this is found in (16), the main thesis of which is described by Sider in the following terms:

The core idea of David Armstrong’s combinatorial theory of possibility is attractive. *Rearrangement* is the key to modality; possible worlds result from scrambling bits and pieces of other possible worlds.(176, p. 679)

The corresponding notion to a combinatorial possible world is a *fusion* of other primitive states that meets certain criteria. In Fine’s paper (84), he provides a corresponding definition of a particular type of state called a *world-state*.

Definition 3.3.6. *A world-state is a state $w \in S^\diamond$ such that for all $s \in S^\diamond$, either $s \sqsubseteq w$ or s is incompatible with w .*

Fine’s world-states are *factually saturated* in the sense that with respect to a world w , every possible state $s \in S^\diamond$ is either part of w —that is, obtains in w —or is incompatible with w in a strong sense. Compare this account of world-states with Armstrong’s (16):

The simplest way to specify a possible world would be to say that *any conjunction* of possible atomic states of affairs, including the unit conjunction, constitutes such a world. (16, p. 47)

It is arguable that invoking possible worlds carries more metaphysical commitments than merely invoking situations or facts. Consistent with this position, Fine shows that classical logic can be recovered without appeal to worlds and chooses to present classical consequence as the preservation of *loose verification* across arbitrary states.

Definition 3.3.7 (Loose Verification). *A state s loosely verifies A —written $s \Vdash_1 A$ —if any state that is compatible with s is compatible with some $t \in [A]$.*

Observation 3.3.1 (Fine). *$A \models_{\text{CL}} B$ is a classically valid inference if for every state space model \mathbf{S} and every $s \in S$, if $s \Vdash_1 A$ then $s \Vdash_1 B$*

But consider Fine’s definition of world-states and assume the natural position that the truth of a statement A at a world w is precisely the existence of a truthmaker $s \sqsubseteq w$ such that $s \Vdash A$.

Then we are free to recast classical entailment—as Restall supposes in (159)—as truth-preservation at any possible world.

Observation 3.3.2. *$A \models_{\text{CL}} B$ if for every state space model and world-state w , if w inexactly verifies A , then w inexactly verifies B .*

Recasting the recapture of classical entailment in this way provides an analogy by which we may represent Restall’s account of entailment and truthmaking. In (159), Restall’s models are taken to represent possible worlds containing truthmakers as their parts. So it is reasonable to consider the following definition relating parts of worlds to worlds themselves:

Definition 3.3.8. *Call a state s w -actual if w is a world and $s \sqsubseteq w$.*

A state's being w -actual is analogous to saying that the state is a truthmaker at w or that w obtains as a fact at w .

Observation 3.3.3. $A \models_{\mathbf{K}_3} B$ iff for every world-state w , w -actual verifier of A contains a w -actual verifier of B

Proof. For left-to-right, we prove the contrapositive. First, if $s \sqsubseteq w$ for a world $w \in S^\diamond$, then for no atom p does $s \Vdash^+ p$ and $s \Vdash^- p$. Suppose that $t \sqsubseteq w$ and $t' \sqsubseteq w$ and $t \Vdash^+ p$ and $t' \Vdash^- p$. Then because $t \sqsubseteq w$ and $t' \sqsubseteq w$, $t \sqcup t' \sqsubseteq w$. But by definition of S^\diamond , that $w \in S^\diamond$ and $t \sqcup t' \sqsubseteq w$ entails that $t \sqsubseteq t' \in S^\diamond$. But by Exclusivity, $t \sqsubseteq t' \notin S^\diamond$.

Hence, with respect to any $s \sqsubseteq w$, for every $p \in \mathbf{At}$, either there is an exact verifier $t \sqsubseteq s$ for p , there is an exact falsifier $t \sqsubseteq s$ for p , or there are no exact verifiers or falsifiers of p that are part of s . We can thus recursively construct a \mathbf{K}_3 valuation v_s by initially assigning values $\{\mathbf{t}\}$, $\{\mathbf{f}\}$, or \emptyset to atoms

$$v_s(p) = \begin{cases} \mathbf{t} & \text{if } \exists t \sqsubseteq s \text{ such that } t \Vdash^+ p \\ \mathbf{f} & \text{if } \exists t \sqsubseteq s \text{ such that } t \Vdash^- p \\ \mathbf{n} & \text{otherwise} \end{cases}$$

The initial valuation can be extended recursively easily. The cases for truth, for example:

$$\begin{aligned}
v_s(\dot{\neg} A) = \mathbf{t} & \quad \text{iff } \exists t \sqsubseteq s \text{ such that } t \Vdash^+ \dot{\neg} A \\
& \quad \text{iff } t \Vdash^- A \\
& \quad \text{iff } v_s(A) = \mathbf{f}
\end{aligned}$$

$$\begin{aligned}
v_s(A \dot{\wedge} B) = \mathbf{t} & \quad \text{iff } \exists t \sqsubseteq s \text{ such that } t \Vdash^+ A \dot{\wedge} B \\
& \quad \text{iff } \exists t, u \sqsubseteq s \text{ s.t. } t \Vdash^+ A \text{ and } u \Vdash^+ B \\
& \quad \text{iff } v_s(A) = \mathbf{t} \text{ and } v_s(B) = \mathbf{t}
\end{aligned}$$

$$\begin{aligned}
v_s(A \dot{\vee} B) = \mathbf{t} & \quad \text{iff } \exists t \sqsubseteq s \text{ such that } t \Vdash^+ A \dot{\vee} B \\
& \quad \text{iff } \exists t, u \sqsubseteq s \text{ s.t. } t \Vdash^+ A \text{ or } u \Vdash^+ B \\
& \quad \text{iff } v_s(A) = \mathbf{t} \text{ or } v_s(B) = \mathbf{t}
\end{aligned}$$

Analogous conditions can be derived in the case of falsity and the third value \mathbf{n} . The \mathbf{K}_3 truth tables can be reconstructed, whence given a world-state w and a w -actual verifier s for B that contains no exact verifier for A , v_s will serve as a \mathbf{K}_3 valuation witnessing that $A \not\equiv_{\mathbf{K}_3} B$, *i.e.*, will verify that $v_s(A) = \mathbf{t}$ and $v_s(B) \neq \mathbf{t}$.

For right-to-left, let v be a \mathbf{K}_3 valuation serving as a counterexample to $A \equiv_{\mathbf{K}_3} B$ and consider the set:

$$L_v = \{\{p\} \mid \text{if } v(p) = \mathbf{t}\} \cup \{\{\dot{\neg} p\} \mid \text{if } v(p) = \mathbf{f}\}$$

Now consider the set $\bigcup L_v$.

Now, $\bigcup L_v$ is a state present in the canonical model described in (87). Moreover, it is a part of many world-states in the canonical model, *e.g.*, the state

$$!L_v = \bigcup L_v \cup \bigcup \{\{p\} \mid \{p, \dot{\neg} p\} \cap (\bigcup L_v) = \emptyset\}$$

An easy induction establishes that $v(A) = \mathbf{t}$ if and only if there exists a state $s \subseteq \bigcup L_v$ such that $s \Vdash A$. Hence, any truth-functional counterexample yields an appropriate part of a

world-state in the canonical model. □

We can also rephrase this by defining a notion of “worldly content” of a statement at a world w . Recall the notation of Definition 3.2.4. Then $\lceil A \rceil^+ \upharpoonright_w$ is the set of the w -actual verifiers of A .

Hence, we are free to rephrase Observation 3.3.3 in the following terms:

Observation 3.3.4. $A \vDash_{\mathbf{K}_3} B$ iff for every world-state w , $\lceil A \rceil^+ \upharpoonright_w \supseteq \lceil B \rceil^+ \upharpoonright_w$

So Restall’s account of \mathbf{K}_3 in terms of state space semantics appears entirely natural. As we’ve suggested, there is some precedent for this, as Barwise and Perry implicitly endorsed this consequence relation in (20).

3.3.3 The Emergence of \mathbf{RM}_{fde}

In the concluding two paragraphs of (159)—immediately after discussing \mathbf{K}_3 as a candidate for a form of “real” entailment—Restall briefly suggests a *second* sense of truthmaker entailment. After observing that $A \dot{\wedge} \dot{\neg} A$ entails an arbitrary formula B in truthmaker entailment in the first sense, Restall suggests this second species of truthmaker entailment in two lines. Where \Rightarrow represents the first sense of “real” entailment, the brief passage is:

But we can get closer to first-degree entailment by setting $A \Rightarrow_2 B$ if and only if $A \Rightarrow B$ and $\dot{\neg} B \Rightarrow \dot{\neg} A$. Then we do not have $A \dot{\wedge} \dot{\neg} A \Rightarrow_2 B$, but we still have $A \dot{\wedge} \dot{\neg} A \Rightarrow_2 B \dot{\vee} \dot{\neg} B$. (159, p. 339)

Granted the role \mathbf{E}_{fde} has played in the semantics of (189) and (21), the attractiveness of “approximating” \mathbf{E}_{fde} is understandable. What is especially interesting—and perhaps a bit surprising—about Restall’s suggestion is the subsequent remark that this second species of truthmaker entailment corresponds to the deductive system \mathbf{RM}_{fde} , *i.e.*, the first-degree fragment of R-Mingle.

From a proof-theoretic perspective, $\mathbf{RM}_{\mathbf{fde}}$ is a relatively natural system. Syntactically, a proof theory for $\mathbf{RM}_{\mathbf{fde}}$ can be defined by enriching the axiomatic definition of $\mathbf{E}_{\mathbf{fde}}$ provided in Definition 3.1.16 with the so-called **Safety** axiom (*cf.* (68)):

$$\mathbf{Safety} \quad \varphi \dot{\wedge} \dot{\rightarrow} \varphi \rightarrow \psi \dot{\vee} \dot{\rightarrow} \psi$$

Of course, we can recognize that **Safety** corresponds to the final valid entailment mentioned by Restall in the earlier quote. Syntactic consequence in $\mathbf{RM}_{\mathbf{fde}}$ thus springs easily from $\mathbf{E}_{\mathbf{fde}}$.

Within the setting of Restall’s models, consequence for $\mathbf{RM}_{\mathbf{fde}}$ can be defined in (159) as follows:

Theorem 3.3.3. (*Restall*) *A* \vDash *B* is valid in $\mathbf{RM}_{\mathbf{fde}}$ if at every Restall model \mathbf{M} , every truthmaker $s \in W$ such that $s \Vdash A$, also $s \Vdash B$ and every truthmaker $s \in W$ such that $s \Vdash \dot{\rightarrow} B$, also $s \Vdash \dot{\rightarrow} A$.

Now, Restall’s presentation of $\mathbf{RM}_{\mathbf{fde}}$ as a logic of *real* entailment is extraordinarily terse and seems to come from nowhere. Although Restall takes care to interpret and motivate the first species of entailment (*i.e.*, \mathbf{K}_3), the paper lacks any explanation of why one might embrace the picture assumed by the second sense of truthmaker entailment. In conjunction with the somewhat unusual semantical account for $\mathbf{RM}_{\mathbf{fde}}$, that Restall floats the system as an account of *real* entailment may be puzzling. By rephrasing Restall’s intuitions in the setting of state space semantics, however, we can provide some insight into why someone may embrace consequence in $\mathbf{RM}_{\mathbf{fde}}$ as a logic of “real” entailment.

Restall’s endorsement is helped little by the fact that from the perspective of many-valued semantics, $\mathbf{RM}_{\mathbf{fde}}$ is a rather odd system. As the axiomatic account suggested, $\mathbf{RM}_{\mathbf{fde}}$ is a proper extension of $\mathbf{E}_{\mathbf{fde}}$, as are Priest’s LP and Kleene’s \mathbf{K}_3 . However, while from the many-valued presentations of LP and \mathbf{K}_3 (*cf.* Definitions 2.3.5, 3.1.17, and 3.3.5), each of *these* subsystems can be defined as restrictions of the matrix $\mathfrak{M}_{\mathbf{E}_{\mathbf{fde}}}$, there is no similar restriction

of the matrix of E_{fde} that yields RM_{fde} . Rather, as shown implicitly by Dunn in (67) (and more explicitly in (68)), many-valued semantics for RM_{fde} are provided by appealing to the *pair* of matrices \mathfrak{M}_{LP} and $\mathfrak{M}_{\text{K}_3}$.¹¹ Semantics for RM_{fde} can be described in terms of the matrix semantics for LP (in Definition 2.3.5) and K_3 (in Definition 3.3.5) as follows:

Definition 3.3.9. $A \vDash_{RM_{\text{fde}}} B$ is valid if

$$\left\{ \begin{array}{l} \text{for all LP valuations } v \text{ s.t. } v(A) \in \mathcal{D}_{\text{LP}}, v(B) \in \mathcal{D}_{\text{LP}}, \text{ and} \\ \text{for all } \text{K}_3 \text{ valuations } v \text{ s.t. } v(A) \in \mathcal{D}_{\text{K}_3}, v(B) \in \mathcal{D}_{\text{K}_3} \end{array} \right.$$

It follows from this presentation that RM_{fde} is the intersection $\text{LP} \cap \text{K}_3$. Now, the lack of a standard matrix semantics for RM_{fde} might be considered a mark against the system. But the characterization of RM_{fde} in Definition 3.3.9 yields a clue concerning how RM_{fde} might be a plausible—perhaps attractive—candidate for an account of truthmaker entailment.

Given the duality between LP and K_3 we have the following observation (which has, for example, been noted by Jc Beall in (22)):

Observation 3.3.5. $A \vDash_{\text{K}_3} B$ if and only if $\dot{\neg} B \vDash_{\text{LP}} \dot{\neg} A$

Hence, an equivalent way of characterizing RM_{fde} consequence would be:

Definition 3.3.10. $A \vDash_{RM_{\text{fde}}} B$ is valid if

$$\left\{ \begin{array}{l} A \vDash_{\text{K}_3} B \text{ is valid, and} \\ \dot{\neg} B \vDash_{\text{K}_3} \dot{\neg} A \text{ is valid} \end{array} \right.$$

A natural interpretation of Definition 3.3.10 would be that RM_{fde} consequence identifies entailment not only with *truth preservation* but also with *non-falsity preservation*. The case of logics of nonsense provide one of the most important examples of interpreting entailment

¹¹It is worth noting that there exists an intriguing connection between Dunn's semantics for RM_{fde} and the more recent *swap structure* semantics introduced by Walter Carnielli and Marcelo Coniglio in (41). In many cases, swap structures are isomorphic to finite collections of logical matrices, enabling Carnielli and Coniglio to show that a number of logics of formal inconsistency (*cf.* (42)) that are not characterizable by a finite matrix have characterizations by *collections* of such matrices.

as non-falsity preservation. For present purposes, we will consider for now Bochvar’s logic of nonsense Σ (and its “internal fragment” Σ_0) outlined in (31) and Halldén’s C introduced in (104) (alongside its “classical fragment” C_0).

Recall that Σ_0 and C_0 differ only in that the latter takes the “nonsense value” to be *designated* while the former does not, *i.e.*, logical consequence to Halldén is construed as ensuring that consequence preserves non-falsity. The motivation for this has enjoyed a number of distinct interpretations. For example, in (195), Timothy Williamson suggests that “[t]he rationale for Halldén’s designation policy is clear” (195, p. 105) asserting that Halldén designates the value u precisely because Σ_0 ’s lacking theorems is a pathology that can be averted in C_0 when nonsense is designated. Halldén’s position is unusual in that designated values are often interpreted as “truthlike,” a property that is hard to attribute to meaningless statements. Ross Brady and Sylvan, for example, reject Halldén’s position by claiming that it commits us “to sometimes asserting logical nonsense.” (38, p. 219)

Halldén is, in fact, sensitive to this, writing that with respect to such an objection,

[t]he answer... is, roughly, that a formula is to be taken as asserting something only about those values of which it can meaningfully assert something. The formula is true if the property or relation it asserts applies to all those values of which it can be meaningfully asserted. (104, p. 47)

The upshot of Halldén’s response is that selection of designated values is determined by concerns about *validity* rather than concerns about *truth*. Whereas, *e.g.*, Brady and Sylvan look at the “local” level and judge the treatment of an individual meaningless sentence as having a “truth-like” property, Halldén is looking to how to judge the validity of an inference *in general*.

The requirement that logical consequence must preserve non-falsity becomes all the more natural when non-falsity preservation is recast in terms of truthmakers. Because of the

entrenchment of \mathbf{E}_{fde} in these types of semantics, it will be useful to observe that in \mathbf{E}_{fde} consequence-as-truth-preservation and consequence-as-non-falsity-preservation coincide. Recasting this observation in terms of truthmaking and falsmaking, this phenomenon can be described in the following observation:

Observation 3.3.6. *The following are equivalent*

1. *In all state space models, $[A]^+ \sqsupseteq [B]^+$*
2. *In all state space models, both $[A]^+ \sqsupseteq [B]^+$ and $[B]^- \sqsupseteq [A]^-$*
3. *In all state space models, $[B]^- \sqsupseteq [A]^-$*

Proof. By the rules for \mathbf{E}_{fde} , $A \rightarrow B$ is valid, *i.e.*, $[A]^+ \sqsupseteq [B]^+$ holds in all models, if and only if $\dot{\neg} B \rightarrow \dot{\neg} A$ is valid. This latter claim is equivalent to $[\dot{\neg} B]^+ \sqsupseteq [\dot{\neg} A]^+$, which is equivalent to $[B]^- \sqsupseteq [A]^-$. \square

Likewise, the type of bipartite scheme represented by \mathbf{RM}_{fde} could have been imposed in, *e.g.*, (189) without any loss of generality.

This observation has consequences for how different entailment relations are construed in state space semantics. For example, if we recall Fine's definition of inexact consequence, Observation 3.3.6 entails that the following provides an equivalent definition for inexact consequence:

Definition 3.3.11. *B is an inexact consequence of A if in any state space model, both*

$$\left\{ \begin{array}{l} [A]^+ \sqsupseteq [B]^+, \text{ and} \\ [B]^- \sqsupseteq [A]^- \end{array} \right.$$

From this observation, then, we can infer that this equivalent notion of inexact consequence will correspond to \mathbf{E}_{fde} as well:

Corollary 3.3.1. $A \models_{\text{E}_{\text{fde}}} B$ if and only if in any state space model, both $\left\{ \begin{array}{l} [A]^+ \sqsupseteq [B]^+, \text{ and} \\ [B]^- \sqsupseteq [A]^- \end{array} \right.$

Now, suppose that someone is taken by Fine’s account of truthmaker semantics but doggedly subscribes to a combinatorialist view, accepting that the only possible states of affairs are those that are actual. Such an individual would presumably wish to follow the general scheme of, *e.g.*, inexact consequence while restricting the verifiers and falsifiers of a formula A by which inexact consequence is evaluated to those that actually obtain in a world w . In other words, such a combinatorialist might embrace a “local logic of inexact consequence.” However, granted the equivalence of Definitions 3.1.18 and 3.3.11, there is no one deductive system that serves as *the unique* local logic of inexact consequence.

Moreover, although equivalent *globally* (*i.e.*, when evaluated against arbitrary states), Definitions 3.1.18 and 3.3.11 diverge *locally* (*i.e.*, when considering only states that are w actual). Let us explicitly represent these notions of local inexact consequence by making the requisite restrictions on Definitions 3.1.18 and 3.3.11, respectively:

Definition 3.3.12. B is a local inexact consequence of A in the first sense if in every state space model and world-state w , $[A]^+ \upharpoonright_w \sqsupseteq [B]^+ \upharpoonright_w$

Definition 3.3.13. B is a local inexact consequence of A in the second sense if in every state space model and world-state w , both $\left\{ \begin{array}{l} [A]^+ \upharpoonright_w \sqsupseteq [B]^+ \upharpoonright_w, \text{ and} \\ [B]^- \upharpoonright_w \sqsupseteq [A]^- \upharpoonright_w \end{array} \right.$

The similarity between these local particularizations of inexact consequence and the characterizations of K_3 and RM_{fde} in state space semantics is pronounced.

For example, if we recall Observation 3.3.4, the following is immediate:

Observation 3.3.7. $A \models_{\mathsf{K}_3} B$ iff B is a local inexact consequence of A in the first sense.

And from the structure of Definition 3.3.13, the claim of RM_{fde} to the mantle of the logic of wordly inexact consequence appears just as legitimate as the claim of K_3 . This observation follows from an alternative formulation of RM_{fde} consequence in state space semantics.

Observation 3.3.8. $A \vDash_{\text{RM}_{\text{fde}}} B$ if in all world-states w , $\left\{ \begin{array}{l} [A]^+ \upharpoonright_w \sqsupseteq [B]^+ \upharpoonright_w, \text{ and} \\ [B]^- \upharpoonright_w \sqsupseteq [A]^- \upharpoonright_w \end{array} \right.$

Proof. As described in (68), consequence in RM_{fde} can be defined so that:

$$A \vDash_{\text{RM}_{\text{fde}}} B \text{ iff } \left\{ \begin{array}{l} A \vDash_{\text{K}_3} B, \text{ and} \\ A \vDash_{\text{LP}} B \end{array} \right.$$

Where LP is Priest's "logic of paradox" of (154) (defined in Definition 2.3.5). Furthermore, we have noted that

$$A \vDash_{\text{K}_3} B \text{ iff } \dot{\neg} B \vDash_{\text{LP}} \dot{\neg} A$$

Granted these observations, we may appeal to Observation 3.3.4 to immediately secure the observation. □

Just as Observation 3.3.4 and Definition 3.3.12 bore a clear resemblance, Observation 3.3.8 allows us to appeal to its similarity to Definition 3.3.13 to draw the following conclusion:

Observation 3.3.9. $A \vDash_{\text{RM}_{\text{fde}}} B$ iff B is a local inexact consequence of A in the second sense.

Not only does this characterization show that RM_{fde} has a legitimate claim as the logic of inexact consequence but it also reflects a natural picture of truthmaking entailment. Note that Observation 3.3.8 boils down to the claim that in any world w , every exact verifier of A contains an exact verifier of B and that every exact falsifier of B contains an exact falsifier of A .

This latter condition may be rephrased as the demand that any *exact-non-falsifier* of A is an *exact-non-falsifier* of B . From a naïve perspective, we expect correct reasoning to preserve non-falsity and this intuition is reinforced once we move from thinking about *truth values* to *truth makers*. We undoubtedly expect of falsifiers that they support this analysis of consequence. When, *e.g.*, a suspected criminal is on trial, the body of evidence employed by the court can count as a truthmaker or falsemaker for his or her testimony. Suppose that the accused has provided an alibi while on the stand; then the role of the prosecution is to employ the body of evidence as a *falsifier* for the accused’s alibi. It seems reasonable to expect that if the evidence *fails* to reveal “I was at Abel’s house at the time the crime was committed” as perjury—if the evidence is too weak to disprove the alibi—then the evidence should also *fail* to reveal “I was either at Abel’s house or Becky’s house during the crime” to be a falsehood.

Note that the K_3 account of “real” entailment fails to validate this intuition. For example, the inference $A \dot{\wedge} \dot{\neg} A \vDash_{K_3} B$ is valid for arbitrary formulae B . Now, for an arbitrary state $s \in S^\diamond$, s is a non-falsemaker for a contradiction $A \dot{\wedge} \dot{\neg} A$. Considering an arbitrary model in which a contingent proposition $\dot{\neg} B$ holds shows that the fact that s is a non-falsemaker for the contradiction does not preclude s from serving as a falsemaker for a contingent proposition B . Hence, RM_{fde} as a type of truthmaker entailment captures intuitions that K_3 does not support.

3.4 Concluding Remarks

Although we have noted that Suszko’s (182) is contemporary to van Fraassen’s (189), Fine’s state space semantics for Angell’s containment logic AC and Correia’s account of Cor are clearly counted in the lineage of van Fraassen’s work. It is worth noting, however, that Parry-type systems in general—and AC in particular—admit analyses within the framework

of Suszko and Bloom's non-Fregean logics from (29) and (30).

In (139), Marek Nowak cites (20) and (21) as motivation for the formulation of a so-called *Barwise and Perry's principle* concerning the identity between two formulae:

BP Two sentences whose logical forms are logically equivalent and have the same extralogical constants, [express the same proposition].

As a particularization of **BP** to the propositional case, Nowak attributes to (197) a constraint he calls *Wójcicki's principle* (**WP**):

WP Two sentences whose logical forms in sentential language are logically equivalent and have the same sentential variables [express the same proposition].

The system so determined can be seen to be the set of first-degree biequivalences in Parry's **PAI**, that is, strong consequence in the propositional case (via Wójcicki) is equivalent to consequence in $\mathbf{PAI}_{\text{fde}}$. Further work in which the containment logics induced by such constraints is developed has appeared by Andrzej Bilat in (27) and (28).

But **AC**, too, has received an analysis within this framework. Tadao Ishii, in (109) and (110) has described systems of propositional logic with identity in which **AC** emerges. It stands to reason that **Cor** can be folded into this framework as well. Although these two traditions—that of van Fraassen and that of Suszko—differ, it should still be worth considering **Cor** and state space semantics through the lens of non-Fregean logic.

Chapter 4

A Computational Interpretation of Conceptivism

One of the hallmark features of the deductive systems known as ‘conceptivist’ or ‘containment’ logics is that the principle of Addition (the inference to $A \dot{\vee} B$ from A) fails. In this chapter, we examine a number of *prima facie* unrelated deductive contexts that do not support Addition and attempt to harmonize them by developing a computational interpretation of conceptivist logics. With a computational interpretation ready-to-hand, further applications of conceptivist systems emerge, including themes in propositional dynamic logic and constructive logic.

4.1 Formal Remarks

In order to be as precise as necessary, we will stop to formally define a number of properties that deductive systems may exhibit before moving on to formally introduce a number of the more well-known conceptivist systems.

For example, we will deal with three distinct propositional languages in the sequel: the

familiar propositional language of zeroth degree formulae \mathcal{L}_{zdf} introduced in Definition 1.1.2 whose logical connectives include negation ($\dot{\neg}$), conjunction ($\dot{\wedge}$), and disjunction ($\dot{\vee}$), the language \mathcal{L}_+ of Definition 1.1.1 that enriches \mathcal{L}_{zdf} by the addition of an intensional conditional connective ($\dot{\rightarrow}$), and a pure implicational language $\mathcal{L}_{\rightarrow}$ whose sole connective is the intensional conditional \rightarrow .

4.1.1 A Family of \rightarrow -Parry Deductive Systems

While a number of \rightarrow -Parry logics have been introduced, some—like Parry’s original system and Sören Halldén’s *S0*, introduced in (103)—lack semantics. There are, however, a number of systems in the literature that can be given a common semantical framework.

Parry, in (144), had enriched his system of (142) and (143) with the axiom:

$$(A \dot{\wedge} \dot{\neg} B) \rightarrow \dot{\neg}(A \rightarrow B)$$

When the matter of analytic implication was taken up by (65), (188), and (81), this axiom was included. However, Parry’s attitude in (144) seems to be that this axiom is in keeping with the *spirit* of his dissertation and, as such, does not represent so much an *extension* of his original system but a *correction* thereto. It is this system—*PAI*—in terms of which the remaining three are motivated.

Dunn’s ‘demodalized’ analytic implication *DAI* follows from the observation that necessity in logics of strict implication can be defined so that $\Box A =_{df} (A \rightarrow A) \rightarrow A$. Hence, adding an axiom $A \rightarrow ((A \rightarrow A) \rightarrow A)$, *i.e.*, $A \rightarrow \Box A$, effectively eliminates modal distinctions and demodalizes the system *PAI*. The addition of this axiom to the logic of strict implication *S4*, for example, collapses the system to classical logic. After providing algebraic semantics for his system, Dunn cites Robert Meyer as suggesting a very simple semantical approach to *DAI*.

The abstract (69) is the first appearance of **DAI** as ‘dependence logic’ as a species of Epstein’s larger program of set-assignment semantics. In (71), in which the system is called ‘**D**,’ retains the truth-function nature of the connectives but adds a function s from **At** to a set of ‘subject-matters.’ A model is thus a pair $\langle v, s \rangle$, where v behaves classically for negation, disjunction, and conjunction, while implication receives evaluations obeying:

$$v(A \rightarrow B) = \begin{cases} \mathbf{f} & \text{if either } s(B) \not\subseteq s(A) \text{ or both } v(A) = \mathbf{t} \text{ and } v(B) = \mathbf{f} \\ \mathbf{t} & \text{otherwise} \end{cases}$$

While finding set-assignment semantics for weaker systems is an interesting question, there are at present no semantics for, *e.g.*, **PAI** in the style of Epstein.

While Dunn and Epstein explore a *strengthened* form of analytic implication, we have encountered Harry Deutsch’s **S**, motivated by the assertion that **PAI** is *overly* strong. For the time being, Deutsch’s **S** will remain the weakest of the systems studied. Recalling the semantics for **S** in Chapter 2, we will characterize the stronger systems in terms of restrictions of **S** models. The language over which these logics are defined is \mathcal{L}^+ .

Deutsch’s semantics are a modification of Fine’s models for **PAI** in (81), which themselves employ Kripke frames. Like other logics with Kripke-style semantics, restricting frames $\langle W, R \rangle$ often yields stronger deductive systems. In the present case, restricting our attention to only models in which R linearly orders W yields the system S' studied in (61).

Definition 4.1.1. $\Gamma \vDash_S A$ iff for all **S** models \mathcal{M} such that $\langle W, R \rangle$ is a linear order and points $w \in W$, if $\mathcal{M}, w \Vdash^+ B$ for all $B \in \Gamma$, then $\mathcal{M}, w \Vdash^+ A$

In (60), Deutsch also defines a system S'' (appearing in his dissertation as “**D**’”) corresponding to the class of **S** models for which W is a singleton.

Definition 4.1.2. $\Gamma \vDash_{S''} A$ iff for all **S** models \mathcal{M} for which W is a singleton $\{w\}$, whenever $\mathcal{M}, w \Vdash^+ B$ for all $B \in \Gamma$, it follows that $\mathcal{M}, w \Vdash^+ A$

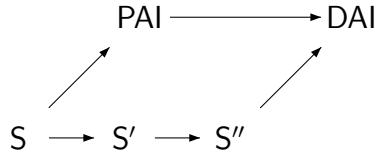
 Figure 4.1: Relationships Between \rightarrow -Parry Systems

As the frames for S'' models are degenerate examples of linear orders, we may observe that S'' is an extension of S .

As is clear from Definition 2.4.1, we may recall that Fine's original semantics for PAI correspond to the class of all S models whose distributions of formulae are consistent, *i.e.*, PAI corresponds to S models for which V^+ and V^- assign only consistent valuations of atoms:

Definition 4.1.3. $\Gamma \models_{\text{PAI}} A$ iff for all S models \mathcal{M} such that for all $p \in \mathbf{At}$, $V^+(p) \cap V^-(p) = \emptyset$, and points w , if $\mathcal{M}, w \Vdash B$ for all $B \in \Gamma$, then $\mathcal{M}, w \Vdash A$

Finally, the Dunn-Epstein system DAI defined as the restriction of PAI to single-pointed frames:

Definition 4.1.4. $\Gamma \models_{\text{DAI}} A$ iff for all S models \mathcal{M} such that

- for all $p \in \mathbf{At}$, $V^+(p) \cap V^-(p) = \emptyset$, and
- W is a singleton $\{w\}$

if $\mathcal{M}, w \Vdash B$ for all $B \in \Gamma$, then $\mathcal{M}, w \Vdash A$.

This definition makes it clear that Dunn's possible worlds semantics and Epstein's set-assignment semantics are equivalent, as the single lattice $\langle C_w, \circ_w \rangle$ is analogous to a set of subject matters in Epstein's set-assignment semantics for D . To wit, the canonical models for DAI and D , the lattice $\langle C_w, \circ_w \rangle$ and the set of subject matters are isomorphic.

The picture of this family of systems is represented by Figure 4.1. As mentioned earlier, other conceptivist systems have been described in the literature, although their semantics do not immediately admit an account in the above terms.¹ For example, Charles Daniels’ story logic—which we will identify as ‘ S^* ’—first described in (54) is a further conceptivist system whose semantics we will omit here.² Daniels’ interpretation of ‘story implication’ employs *stories* as its primitive semantical device so that $A \rightarrow B$ is valid in S^* if in every ‘story’ in which A is true, B is also true. Daniels suggests that if a story is thought to have a ‘cast,’ one must ‘discard the idea that if A is in a story, $A \dot{\vee} B$ and $B \dot{\vee} A$ are also in it,’ as the sentence denoted by B , after all, may ‘introduce new and unwanted characters.’ (54, p. 222) Daniels acknowledges the proximity to Parry’s system and motivates the *de facto* rejection of Addition on the basis of *names*—a wholly syntactic, yet not *ad hoc*, motivation.

Daniels’ system deserves special mention as its first-degree fragment S_{fde}^* will play a role in the sequel.

4.1.2 A Family of \vdash -Parry Deductive Systems

Many of the \vdash -Parry systems in the literature—and other propositional logics with which we will be concerned—can be semantically characterized by a simple set of matrices. Central will be the system S_{fde}^* , which makes up the first-degree fragment of Daniels’ S^* . Properly speaking, Angell first described this deductive system in passing in his abstract (9), in which S_{fde}^* is described as the logic corresponding to the intersection $E_{fde} \cap PAI_{fde}$.³ An axiomatic account of S_{fde}^* was independently introduced by Daniels in (55), in which Daniels declared

¹Included among these systems is Parry’s original AI of (142) and (143) for which no corresponding semantics has been introduced.

²Although Daniels’ semantics does not immediately conform to the underlying semantical picture described in, *e.g.*, Definitions 2.4.1 and 2.4.4, the intuitions implicit in his work on these systems (*e.g.*, (54), (55), (56)) bear many similarities to Parry’s own work. Thus, it is plausible that S^* might be given semantics within a modification of Fine’s framework, although we set this aside for future work.

³Proof of the identity of S_{fde}^* and Angell’s $E_{fde} \cap PAI_{fde}$ has not appeared in the literature but proof of this identity will be provided in Observation 5.4.1.

without proof that S_{fde}^* coincided with the first-degree fragment of his logic with ‘story semantics.’⁴ The truth-functional semantics for this system was independently discovered by Graham Priest in (156) as “FDE_φ” in the context of the *catuskoṭi*, an element of Buddhist dialectics, in which Priest enriches the truth values of E_{fde} (*cf.* Definition 3.1.17) with a fifth semantical value u (called “ ϵ ” by Priest) that formalizes an alethic value corresponding to *emptiness*, following Priest’s interpretation of remarks made by the Buddhist philosopher Nāgārjuna.

The semantical presentation of S_{fde}^* we will employ, like Priest’s account in (156), can be interpreted as an enrichment of the set of truth values $\mathcal{V}_{E_{fde}}$ with an additional, infectious value.

Definition 4.1.5. *The logic S_{fde}^* is the deductive system induced by the matrix $\mathfrak{M}_{S_{fde}^*}$:*

$$\langle \mathcal{V}_{S_{fde}^*}, \mathcal{D}_{S_{fde}^*}, f_{S_{fde}^*}^{\dot{\neg}}, f_{S_{fde}^*}^{\dot{\wedge}}, f_{S_{fde}^*}^{\dot{\vee}} \rangle$$

Where $\mathcal{V}_{S_{fde}^*} = \{t, b, u, n, f\}$ (i.e., $\mathcal{V}_{E_{fde}} \cup \{u\}$) and $\mathcal{D}_{S_{fde}^*} = \{t, b\}$.

The truth functions $f_{S_{fde}^*}^{\dot{\neg}}$, $f_{S_{fde}^*}^{\dot{\wedge}}$, and $f_{S_{fde}^*}^{\dot{\vee}}$ are defined by the matrices:

$f_{S_{fde}^*}^{\dot{\neg}}$		$f_{S_{fde}^*}^{\dot{\wedge}}$	t	b	u	n	f	$f_{S_{fde}^*}^{\dot{\vee}}$	t	b	u	n	f
t	f	t	t	b	u	n	f	t	t	t	u	t	t
b	b	b	b	b	u	f	f	b	t	b	u	t	b
u	u	u	u	u	u	u	u	u	u	u	u	u	u
n	n	n	n	f	u	n	f	n	t	t	u	n	n
f	t	f	f	f	u	f	f	f	t	b	u	n	f

The Belnap-Dunn system E_{fde} and the Deutsch-Oller system S_{fde} can be clearly defined by placing additional conditions on the valuations of \mathbf{V} , *e.g.*, E_{fde} corresponds to validity with respect to S_{fde}^* valuations v such that $u \notin v[\mathbf{At}]$.

⁴Problematically, Daniels, like Deutsch, calls his intensional system “S” in (55), ensuring that the notation “ S_{fde} ” is ambiguous when unqualified. Decorating Daniels’ system with a star was introduced in (79) to distinguish the two first-degree systems.

The final first-degree conceptivist system playing a role in this chapter is Johnson’s system RC from (116), semantics for which was described in Definition 2.3.3.

Inspection of the matrices yields a few important facts concerning the relationship between these systems. In particular, we provide a particular schematic analysis of validity in the systems S_{fde}^* , S_{fde} , and RC. Recall Gödel’s conjecture of (101) that Parry’s system of *analytic implication* AI would permit what Sylvan called a ‘double-barrelled’ analysis, according to which the theoremhood of a formula A (or validity of an inference $A \vdash B$) in a deductive system L can be characterized by a pair of constraints: Validity in a distinct system L' in conjunction with the satisfaction of some syntactic criterion by the formula A .

We have noted that a property closely related to Gödel’s conjecture was confirmed for PAI by Kit Fine in (81), in which it was demonstrated that the Lewis system **S4** serves as the “carrier logic” for PAI. In light of this, we will call an account of a containment logic in which the logic is characterized by a distinct system L with a syntactic sieve a *Gödel-Fine analysis*.

The truth functional semantics for S_{fde}^* is sufficiently rich to allow the Gödel-Fine analysis of S_{fde}^* .

Observation 4.1.1. $A \models_{S_{fde}^*} B$ iff $\left\{ \begin{array}{l} A \models_{E_{fde}} B, \text{ and} \\ \mathbf{At}(B) \subseteq \mathbf{At}(A) \end{array} \right.$

Proof. For left-to-right, because all E_{fde} valuations are trivially S_{fde}^* valuations, that $A \models_{S_{fde}^*} B$ entails that $A \models_{E_{fde}} B$. Moreover, it is shown in (140) that for the system S_{fde} —of which S_{fde}^* is itself a subsystem— $A \models_{S_{fde}} B$ entails that $\mathbf{At}(B) \subseteq \mathbf{At}(A)$. As a subsystem of S_{fde} , whenever $A \models_{S_{fde}^*} B$, we may infer that $A \models_{S_{fde}} B$ and by transitivity, that $\mathbf{At}(B) \subseteq \mathbf{At}(A)$.

For right-to-left, suppose that $A \models_{E_{fde}} B$ and that $\mathbf{At}(B) \subseteq \mathbf{At}(A)$ although $A \not\models_{S_{fde}^*} B$. Then there is an S_{fde}^* valuation v such that $v(A) \in \mathcal{D}_{S_{fde}^*}$ but $v(B) \notin \mathcal{D}_{S_{fde}^*}$. That $v(A) \in \mathcal{D}_{S_{fde}^*}$ and $\mathbf{At}(B) \subseteq \mathbf{At}(A)$ tells us that for no $p \in \mathbf{At}(B)$ is $v(p) = \mathbf{u}$. By the truth functional

nature of $\mathbf{S}_{\text{fde}}^*$, any valuation v' agreeing with v on the elements of $\mathbf{At}(A)$ will likewise map A to an element of $\mathcal{D}_{\mathbf{S}_{\text{fde}}^*}$ with $v'(B) \notin \mathcal{D}_{\mathbf{S}_{\text{fde}}^*}$.

□

Likewise, Observation 2.3.8 can be rephrased in the style of the Gödel-Fine analysis of \mathbf{S}_{fde} :

Observation 4.1.2. $\Gamma \vDash_{\mathbf{S}_{\text{fde}}} A$ iff $\left\{ \begin{array}{l} \Gamma \vDash_{\text{LP}} A, \text{ and} \\ \mathbf{At}(A) \subseteq \mathbf{At}[\Gamma] \end{array} \right.$

In a sense, then, $\mathbf{S}_{\text{fde}}^*$ and \mathbf{S}_{fde} are the conceptivist fragments (or, more formally, the \vdash -Parry fragments) of \mathbf{E}_{fde} and LP, respectively.

Johnson's RC admits a similar analysis. Let $\text{Con}(\Gamma)$ represent the statement that Γ is classically consistent, *i.e.*, that there is a classical valuation mapping each of its formulae to \mathbf{t} and let \vDash_{CL} denote semantic consequence for the classical propositional calculus. Then we have the analysis:

Observation 4.1.3. $\Gamma \vDash_{\text{RC}} A$ iff $\left\{ \begin{array}{l} \text{Con}(\Gamma), \\ \Gamma \vDash_{\text{CL}} A, \text{ and} \\ \mathbf{At}(A) \subseteq \mathbf{At}[\Gamma] \end{array} \right.$

These systems bear a tidy relationship with one another, which can be made still tidier by defining the first-degree fragment of PAI. As (166) observes, PAI_{fde} enjoys the following property:

Observation 4.1.4. $\Gamma \vDash_{\text{PAI}_{\text{fde}}} A$ if $\left\{ \begin{array}{l} \Gamma \vDash_{\text{CL}} A, \text{ and} \\ \mathbf{At}(A) \subseteq \mathbf{At}[\Gamma] \end{array} \right.$

Then we have the series of containments pictured in Figure 4.2. With these formal remarks, we are prepared to move forward.

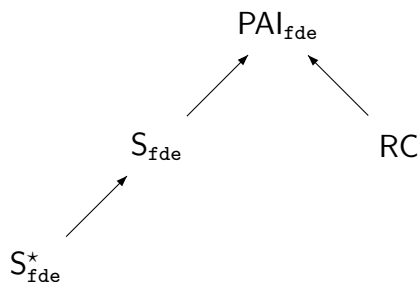
Figure 4.2: Relationships Between \vdash -Parry Systems

4.2 The Failure of Addition

Recall that after identifying Parry’s position with the failure of Addition, Sylvan rejects the Kantian interpretation of conceptivist logics. If the quasi-Kantian motivation for Parry’s intuitions is indeed ‘narrow and arbitrary’ and fails to motivate a rejection of Addition, then what sort of case can be made in support of rejecting Addition? By casting the net a bit more widely and examining a number of logical and linguistic enterprises that each independently entail a rejection of the principle of Addition, we may begin filling in alternative motivations for conceptivism. Some of the areas we will discuss are the so-called ‘logics of nonsense’ and species of disjunction described as ‘intensional disjunction,’ ‘free choice disjunction,’ and ‘cut-down disjunction.’⁵

4.2.1 Meaninglessness

The class of logics of nonsense, such as the truth-functional systems described by Dmitri Bochvar and Sören Halldén in (31) and (104), respectively, are held together by the thesis that some syntactic objects masquerading as propositions are in fact meaningless, in some sense of the term. Supposing that this is the case, the usual semantics for classical logic is ill-equipped to account for such a circumstance as it presupposes that all formulae are

⁵A thorough investigation into the nature of disjunction in general can be found in (113).

meaningful ‘out of the gate’; in general, semantic treatments of logics of nonsense employ a truth-value corresponding to meaninglessness or nonsense.⁶ Bochvar’s system—with which we are primarily concerned—has two sets of connectives, ‘external’ connectives which act as projection operators mapping all arguments to either truth or falsity and ‘internal,’ non-projective connectives.

Importantly, the system enjoys what Lennart Åqvist labels the ‘doctrine of the predominance of the atheoretical element,’ that is, that with respect to the internal connectives (which Bochvar takes to correspond to the classical, logical connectives of, *e.g.*, the *Principia Mathematica*), the meaningless value is ‘infectious.’ Nonsense propagates from atomic formulae to complex formulae so that a subformula’s being nonsense entails that the complex formula is likewise nonsense when all the connectives in the complex formula are internal connectives.

We may recall the internal or classical calculi of Bochvar and Halldén defined in Definitions 2.2.4 and 2.2.5, respectively and note that these systems differ only in that both **t** and **u** are designated in C_0 .

By examining the matrices, the infectiousness of the nonsense value **u** is sufficiently clear to demonstrate the failure of Addition in Σ_0 . Bochvar’s system is truth-functional, whence altering v to a valuation v' mapping some $B \notin \mathbf{At}(A)$ to **u** will not interfere with its mapping A to **t**. But by the infectiousness of the nonsense value, v' will map $A \dot{\vee} B$ to the nonsense value with ‘ $\dot{\vee}$ ’ denoting internal disjunction. So $A \not\vdash_{\Sigma_0} A \dot{\vee} B$.⁷ The motto of the Bochvar account might be summarized as ‘all subformulae must be meaningful.’ In other words, in natural language, we have the following property:

⁶But *cf.* Timothy Smiley’s interpretation in (177), according to which a formula assigned the meaningless value of Bochvar *has* a sense but merely *fails to denote* a proper truth-value.

⁷Bochvar’s system fails to satisfy Parry’s Proscriptive Principle only because, *e.g.*, contradictions cannot take a designated value and B follows from $A \dot{\wedge} \dot{\neg} A$ vacuously.

$$A \dot{\vee} B \text{ is true iff } \left\{ \begin{array}{l} \text{either } A \text{ is true or } B \text{ is true, and} \\ A \text{ is meaningful, and} \\ B \text{ is meaningful} \end{array} \right.$$

A further consequence is more epistemic in nature. Bochvar’s intuition concerning infectious nonsense values entails that *in general* the truth of a formula $A \dot{\vee} B$ cannot be established by merely examining, *e.g.*, A and determining that it is true. The doctrine of the predominance of the atheoretical element entails that in order to confirm that a disjunction is true, for each disjunct some *procedure* must be carried out to *check* whether both disjuncts are meaningful.

4.2.2 Intensional Disjunction

In Section 1.1.2, one of the distinguishing features of relevant logics was identified as the rejection of Disjunctive Syllogism. Yet this rejection was cited in the context of disjunction as employed by the proof of ECQ outlined by C. I. Lewis, a species of disjunction that Anderson and Belnap label the ‘truth-functional “or”.’ With respect, however, to *intensional* disjunction, there are instances in which instances of Disjunctive Syllogism are in fact valid inferences:

On the other hand the intensional varieties of ‘or’ which do support the disjunctive syllogism are such as to support corresponding (possibly counterfactual) subjunctive conditionals. When one says ‘that is either *Drosophila melanogaster* or *D. virilis*, I’m not sure which,’ and on finding that it wasn’t *D. melanogaster*, concludes that it was *D. virilis*, no fallacy is being committed. But this is precisely because ‘or’ in this context means ‘if it isn’t one, then it is the other.’ (6, p. 22)

This condition—that a disjunction is conditional-supporting—is the hallmark of an inten-

sional disjunction on the relevant account, in which it is often symbolized by ‘ \oplus ’ and referred to as ‘fission.’ The disjuncts in the *Drosophila* case ostensibly share a relationship lacking in, *e.g.*, the disjuncts in the statement ‘either Napoleon was born in Corsica or else the number of the beast is perfect,’ namely a conditional assertion that the falsehood of one entails the truth of the other.

If an intensional disjunction carries with it the assertion of such a relationship, then Addition must fail with respect to fission. To use Anderson and Belnap’s example, while it is true that Napoleon was born in Corsica, it hardly follows that the falsehood of this statement would counterfactually entail any arbitrary proposition.

If it is a criterion of relevance between disjuncts that distinguishes the species of disjunction modulo which Addition is valid from those for which it fails, then it is not immediately apparent what the failure of Addition for intensional disjunction has to do with the failure of Addition for Bochvar’s disjunction. The internal disjunction of Bochvar naturally seems to fall into the category of truth-functional disjunctions. Models for Σ_0 are, after all, just functions from atoms to truth values. Moreover, Anderson and Belnap’s criterion that intensional disjunctions ‘support corresponding... subjunctive conditionals’ (6, p. 22) seems to fail for Bochvar’s internal disjunction. For example, Anderson and Belnap’s example of a paradigmatic *non*-intensional disjunction—‘either Napoleon was born in Corsica or else the number of the beast is perfect’—appears to be true by the lights of a logic of nonsense. Each disjunct is plausibly meaningful and the former is true although there remains no support for the corresponding conditional.

However, viewing the two species of disjunction available to the relevant logician from a different perspective in fact sheds light on this situation. The rule for introducing fission on the right in Gentzen-style sequent calculi (as presented in (160)) is as follows:

$$[\oplus R] \frac{\Gamma \vdash \Delta, A, B}{\Gamma \vdash \Delta, A \oplus B}$$

Reviewing (98), this also can be seen as an instance of the right introduction rule for the multiplicative disjunction \wp of Jean-Yves Girard's linear logic, a species of disjunction for which Addition fails as well.

If we look to the proof theory for Σ_0 , however, we find that *proof theoretically*, the truth-functional disjunction of Bochvar and the intensional disjunction of Anderson and Belnap or Girard behave identically. In Marcelo Coniglio and María Corbalán's Gentzen-style proof theory for Σ_0 found in (48), the introduction rule for disjunction has the following form:

$$[\dot{\vee} R] \frac{\Gamma \vdash \Delta, A, B}{\Gamma \vdash \Delta, A \dot{\vee} B}$$

In isolation, then, both fission and Bochvar's disjunction appear to be mere notational variants of one another.

When one includes the structural rule of Right Weakening, that is,

$$[\text{Wk } R] \frac{\Gamma \vdash \Delta}{\Gamma \vdash \Delta, A}$$

it is immediate that the rules corresponding to classical and intensional disjunction correspond in the sense that a sequent $\Gamma \vdash \Delta, A \dot{\vee} B$ is derivable if and only if $\Gamma \vdash \Delta, A \oplus B$ is derivable. In other words, granted Right Weakening, we can introduce extensional and intensional disjunction in precisely the same contexts.

It is reasonable to question whether one ought to identify what Bochvar calls 'disjunction' with disjunction as is practiced in natural language. It seems that this observation provides a fair response, via the famous remark of Gentzen:

The introductions represent, as it were, the 'definitions' of the symbols concerned, and the eliminations are no more, in the final analysis, than the consequences of these definitions. (95, p. 80)

From the standpoint of Gentzen, then, these connectives have identical meanings; the differences are a function of external factors, *e.g.*, what structural rules are accepted.

A further semantic point can be made from observing the rules for fission and internal disjunction. Bochvar's intuition concerning infectious nonsense values entails that *in general* the truth of a formula $A \dot{\vee} B$ cannot be established by merely examining, *e.g.*, A and determining that it is true. The doctrine of the predominance of the atheoretical element entails that in order to confirm that a disjunction is true, for each disjunct some *procedure* must be carried out to *check* whether both disjuncts are meaningful.

This picture is only reinforced by looking to the proof theory. We are unable to add new formulae at will to the succedent position in order to yield new disjunctions. Each disjunct must have been introduced into the proof by some nontrivial means, *i.e.*, there was some rationale for introducing each disjunct. Along with the relevant logicians, one can interpret this criterion as a demand that each disjunct must bear *relevance* to the set of assumptions. However, we can view this just as easily as the demand for the existence of a procedure or mechanism by which each disjunct has been introduced.

4.2.3 Free Choice Disjunction

A further cue may be taken from the analysis of 'free choice disjunction' as described by Thomas E. Zimmerman in (201). Zimmerman's interpretation of disjunction is intended to solve a puzzle about the distribution of modal operators over disjunction in natural language, the so-called 'free choice permission' problem:

how can it be that sentences of the form 'X may A or B' are usually understood as implying 'X may A and X may B'? (201, p. 255)

There is no operator \bigcirc in the standard modal logics according to which $\bigcirc(A \dot{\vee} B)$ entails $\bigcirc A \wedge \bigcirc B$, although when ' \bigcirc ' is read as a deontic operator representing 'agent α may...' this seems to follow in natural language.⁸ The puzzle is thus how to find a reasonable and

⁸There *are* operators which satisfy this inference, *e.g.*, da Costa's consistency operator \circ (an account of

intuitive semantical model supporting this type of inference.

Zimmerman's solution to this problem involves an atypical, formal treatment of disjunction, in which a disjunction $A \dot{\vee} B$ is read as a *list* of epistemic possibilities, *i.e.*, 'A is possible (for all I know) and B is possible (for all I know).' The naïve semantical approach to disjunction treats propositions as collections of epistemic possibilities and invokes the following three conditions to evaluate a disjunction $A \dot{\vee} B$:

$$A \dot{\vee} B \text{ is true iff } \left\{ \begin{array}{l} \text{either } A \text{ is the case or } B \text{ is the case, and} \\ A \text{ might be the case, and} \\ B \text{ might be the case} \end{array} \right.$$

Zimmerman offers 'closed' and 'open' readings of disjunction. A disjunction is called *closed* if at least one of the disjuncts is thought to hold and *open* if the list is not believed to be exhaustive, *i.e.*, closed disjunction must satisfy all three conditions while open disjunction must satisfy only the latter two.

Importantly, disjunction enjoys what might be read as a 'disjunction-as-weak-conjunction' paradigm since Zimmerman's approach unavoidably makes use of conjunction. With respect to the 'list' reading, a list is in a strong sense a *conjunction* of items; on the above truth condition, one must employ conjunction to ensure that the second and third clauses are satisfied. Hence, that it is a disjunction over which 'may' distributes is thus merely apparent; the list's being a *conjunction* of possibilities entails that 'may' distributes over a *conjunction*. This is far less problematic: in virtually any modal logic stronger than **S1**, necessity and possibility operators distribute over conjunction.

That Addition must be rejected relative to either species of free choice disjunction is clear. That A is true *says nothing* concerning whether B is possible; indeed, B may be thought to be impossible, whence $A \dot{\vee} B$ will not hold. Hence, with respect to free choice disjunction,

which may be found in (42)) or the '...is meaningful' operator $+$ of Halldén's nonsense logic introduced in (104). Yet there is no clear way to interpret such operators as giving rise to a reading of 'may.'

$A \dot{\vee} B$ does not follow from A . We will consider the motto of free choice disjunction to be ‘all subformulae must be possible.’

The problem of free choice permission and purported solutions to it will play a role in matters to be discussed in Section 4.4.1; for now, we will continue surveying paradigms of disjunction in which Addition fails.

4.2.4 Cut Down Disjunction

So, one might challenge the validity of Addition out of concerns related to meaninglessness or related to relevance. Although these appear to be *prima facie* distinct concerns, the two begin to coincide in the treatment of disjunction described by Melvin Fitting as ‘cut-down disjunction.’

In (91), Fitting provides an account of generalizing the interpretation of the internal Bochvar logic (represented in Fitting’s paper as the weak Kleene three-valued logic) to the case of bilattices. Fitting considers bilattices $\mathcal{B} = \langle B, \leq_t, \leq_k \rangle$, where \leq_t is the ‘truth ordering’ on the underlying set B and \leq_k represents the ‘information ordering.’ For elements $a, b \in B$, $a \leq_k b$ means that a is more informative than b ; *e.g.*, in the case in which experts supply *both* evidence for and against a formula A , this is maximally informative or constituting ‘information overload.’ Each ordering gives rise to independent join and meet operators; \oplus and \otimes , respectively, in the case of \leq_k and \vee and \wedge the case of \leq_t .

Continuing with this example: Fitting offers the interpretation of the semantical value of a formula A as a pair $\langle P_i, N_i \rangle$, where P_i and N_i are construed as groups of experts (alternately, collections of data or evidence). P_i denotes those *in support* of A and N_i denotes those *against* A , respectively. Such an account of semantical values is closely related to the interpretation offered by Belnap in the paper (23), in which an artificial reasoner evaluates formulae A in terms of whether it has received affirmations or denials of A . On this interpretation, the operation \vee is defined so that the alethic join of elements $\langle P_0, N_0 \rangle$ and $\langle P_1, N_1 \rangle$ is

$\langle P_0 \cup P_1, N_0 \cap N_1 \rangle$. This gives a natural interpretation of disjunction, which, indeed, is in harmony with Belnap's interpretation. In this setting, the operations \oplus and \otimes are defined so that $\langle P_0, N_0 \rangle \oplus \langle P_1, N_1 \rangle =_{df} \langle P_0 \cup P_1, N_0 \cup N_1 \rangle$ and $\langle P_0, N_0 \rangle \otimes \langle P_1, N_1 \rangle =_{df} \langle P_0 \cap P_1, N_0 \cap N_1 \rangle$.

In the case of the internal Bochvar logic, when considering the semantical status of a conjunction or disjunction, Fitting offers an interpretation in which one is interested only in the opinions of experts who have opined on both conjuncts or disjuncts. As it 'cuts down' the field of acceptable data, Fitting describes this species of disjunction as 'cut-down disjunction.' Let us sketch this out: Given a formula A with value $\langle P_0, N_0 \rangle$, the value assigned to $A \oplus \dot{\neg} A$ is $\langle P_0 \cup N_0, P_0 \cup N_0 \rangle$. The intended reading of the value $\langle P_0 \cup N_0, P_0 \cup N_0 \rangle$ is an ordered pair each element of which comprises the collection of experts who maintain an opinion concerning A , that is, those experts who have either provided information supporting A or have provided evidence against A . We will say that $\llbracket A \rrbracket$ is the *cut-down* of A that represents the proposition that there is sufficient evidence to evaluate A . Then the operation which corresponds to evaluating a disjunction against the opinions of the group of experts opining on both disjuncts will be defined as follows:

$$A \nabla B =_{df} (A \dot{\vee} B) \otimes \llbracket A \rrbracket \otimes \llbracket B \rrbracket$$

Reading \otimes as a species of conjunction, it becomes apparent that Bochvar's logic admits an interpretation that bears at least a superficial resemblance to Zimmerman's free choice disjunction. Fitting's analysis of this type of disjunction is that $A \dot{\vee} B$ is designated if $A \nabla B$ is designated on the bilattice. In English,

$$A \nabla B \text{ is true iff } \left\{ \begin{array}{l} \text{some group of experts } X \text{ supports either } A \text{ or } B, \text{ and} \\ \text{all members of } X \text{ have opined on } A, \text{ and} \\ \text{all members of } X \text{ have opined on } B \end{array} \right.$$

Addition clearly fails in the context of cut-down disjunction as well; that a group of experts has affirmed A to be true does not entail that *anyone* has provided any evidence concerning B , either in its favor or against it.

We will return to examine Fitting's cut-down operations with much more detail in Chapter 6.5. For now, note that, beyond the reappearance of a tripartite analysis of disjunction, Fitting's interpretation of cut-down disjunction also supports the theme of the necessity of some procedure surveying each component of a formula that we had found in each of the above cases. That it is a requirement that all members of some group of experts have given an assessment of each disjunct appears similar to the demand that such a psychological procedure exists (in the case of logics of nonsense) or a proof-theoretic procedure exists (in the case of intensional disjunction in relevant and linear logics). In each species of disjunction for which Addition fails, the demand that both disjuncts are *surveyed* in some manner is a necessary condition for the truth of a disjunction $A \dot{\vee} B$.

4.3 Towards a Computational Interpretation

Although Fitting's analysis of the internal Bochvar logic draws together some formal aspects of nonsense and free choice disjunction contexts, it fails to bring together the notions of meaningfulness and possibility. In the case of a disjunction, that one cuts down the data to experts opining on each disjunct does not intuitively admit an interpretation in terms of possibility, as experts uniformly condemning (*i.e.*, opining negatively on) both disjuncts would still make the cut. Nor does it say much about meaningfulness. Nevertheless, we find the same tripartite scheme demanding that not only must one of the disjuncts be true, but that each must possess some further property. That these species of disjunction admit analyses so similar to one another in form suggests that they are related. In this section, we consider an interpretation of conceptivist logic that harmonizes the Bochvar-Halldén demand

that subformulae be meaningful with the Zimmerman-type demand that subformulae be epistemically possible.

We may take a cue from John McCarthy’s computational interpretation—in terms of partial functions—found in (132), in which a novel deductive system is introduced. McCarthy’s system, while supporting Addition as a valid inference, abandons an inference similar to Addition; while $A \vDash A \dot{\vee} B$ is accepted, $A \vDash B \dot{\vee} A$ is rejected. This is explained in terms of the terminating (or not) of procedures tasked with evaluating subformulae.

Suppose that p is false and q is undefined; then... $p \wedge q$ is false and $q \wedge p$ is undefined. This unsymmetry... turns out to be appropriate in the theory of computation since if a calculation of p gives F as a result q need not be computed to evaluate $p \wedge q$, but if the calculation of p does not terminate, we never get around to computing q .(132, pp. 40–41)

Clearly, considering the truth of $p \dot{\vee} q$ rather than the falsity of $p \wedge q$ yields a similar result. Arnon Avron and Beata Konikowska formalize the disjunction of ‘McCarthy logic’ in (18), providing a matrix semantics for the McCarthy logic M :

Definition 4.3.1. *The McCarthy logic M is defined by the matrix $\langle \mathcal{V}_M, \mathcal{D}_M, f_M^{\dot{\wedge}}, f_M^{\dot{\vee}}, f_M^{\dot{\vee}} \rangle$. The extensions of the members of the matrix are given so that $\mathcal{V}_M = \{t, u, f\}$, $\mathcal{D}_M = \{t\}$, and the truth functions are determined by the matrices:*

$f_M^{\dot{\wedge}}$		$f_M^{\dot{\vee}}$	t	u	f	$f_M^{\dot{\vee}}$	t	u	f
t	f	t	t	u	f	t	t	t	t
u	u	u	u	u	u	u	u	u	u
f	t	f	f	f	f	f	t	u	f

The evaluation of a complex formula in McCarthy logic is left-to-right, in what is sometimes known as a ‘lazy evaluation.’ Consider, for example, a disjunction $A \dot{\vee} B$ in which A is

evaluated as \mathbf{t} and B is assigned a value of \mathbf{u} . In some paradigms in which the disjunction is evaluated from left-to-right, the discovery that A is true to conclude that the disjunction is true without having to consider the value assigned to B . If the assignment of the value \mathbf{u} to B indicates that a catastrophic error is triggered whenever one attempts to retrieve the value of B , in those cases in which $A \dot{\vee} B$ can be evaluated without retrieving a value for the rightmost subformula B the accompanying error will be avoided. There exist programming languages, such as Lisp, in which the ‘lazy,’ McCarthy-style operators exist alongside their Boolean counterparts.

The nonsense value \mathbf{u} has so far been given many readings: \mathbf{u} represents ‘undefined’ in the partial function reading, or nonsense in the Bochvar-Halldén setting, or ineffability in Priest’s interpretation of $S_{\mathbf{f}\mathbf{a}\mathbf{e}}^*$. In the present case, however, the value \mathbf{u} may be given a more concrete readings as ‘the routine evaluating this formula fails to terminate.’⁹

McCarthy assumes that the system evaluates a formula sequentially rather than in parallel. If the routine evaluates p and finds it to be true, it terminates and evaluates the complex formula as true, even if it *would have* been stuck in a loop upon evaluating q . In this case, the latter procedure is never called and hence never given the *opportunity* to fail. However, under any circumstance in which the subroutine evaluating p fails to terminate, the complex routine evaluating the disjunction will itself never terminate; it will never get around to calling the procedure to evaluate q . In a parallel context, the counterpart slogan will be that if one of the subprocedures evaluating p and q fails to terminate, $p \dot{\vee} q$ will never be evaluated.

This motivates us to ask under which conditions a system may fail to terminate while evaluating a subformula, and whether such occasions say anything about possibility and meaningfulness.

⁹The truth value \mathbf{u} is represented as ‘ \mathbf{e} ’ in (18) for ‘error.’

4.3.1 Ill-Formedness

We have observed in foregoing sections (*e.g.*, Sections 2.2 and 3.2.3) the coincidence of the themes of meaningfulness and possibility implicit within the context of logics of nonsense. If we recall the remarks made by Åqvist while describing his own system of nonsense logic, who concedes in (1, p. 151) that there *are* circumstances in which the doctrine of the predominance of the atheoretical element clearly holds. In labeling ill-formed formulae ‘statements’ and professing that they exhibit a particular type of semantical behavior, Åqvist may be interpreted as suggesting that ill-formed formulae constitute paradigmatic examples of syntactical objects that, while meaningless, still demand a logical analysis. Indeed, Åqvist’s rejection of this doctrine is due only to the intuition that the class of ill-formed formulae does not exhaust the class of meaningless statements.

We may try to apply Åqvist’s comment associating meaningfulness with well-formedness to shine light on the interpretation of disjunction in Σ_0 and C_0 . Before judging some string of symbols to be true (or false), one must determine that the string is in fact a well-formed formula and this demands that all its components must be *surveyed*. Otherwise, there exists an open invitation to error.

We can employ a concrete illustration—along the lines of the treatment of conjunction in (132)—to demonstrate that there is something intuitively correct about this picture. Suppose for a moment that merely securing the truth of the first disjunct were sufficient to establish the truth of a disjunction. Then, for example, we could design an algorithm to evaluate a string of symbols interpreted as positive disjunctive formulae as represented in Figure 3.

At first blush, examining a few cases suggests that such an algorithm is sufficient for the task. If p is true (*i.e.*, $v(p) = 1$) and we feed in $\lceil p \dot{\vee} q \rceil$, then the algorithm returns true (by assigning a value of 1 to x); if we feed in $\lceil q \dot{\vee} p \rceil$, it returns true. Likewise, if $v(p)$ and $v(q)$ are both 0, the algorithm will not affirm the string $\lceil p \dot{\vee} q \rceil$. The algorithm treats these

```

procedure DISJUNCTIVE(v,s)
  read s
  if  $s = p_i$  then
    if  $v(p_i) = 1$  then
       $x \leftarrow 1$ 
      return
    else
      move Right
      call Disjunctive
    end if
  else
    move Right
    call Disjunctive
  end if
end procedure

```

Figure 4.3: McCarthy-style Algorithm Interpreting Disjunction

formulae correctly and, more importantly, it apparently does so for the right reason: It finds a disjunct that is valued as true and, on that basis, reports that the disjunction is true.

Consider, however, the case in which p is true and one inputs the string $\lceil p \dot{\vee} \dot{\vee} \rceil$ to the algorithm. It reads a propositional variable in the initial position of the string, proceeds to examine the variable, and, finding this disjunct to be true, judges the entire string to represent a true formula. Arguably, $\lceil p \dot{\vee} \dot{\vee} \rceil$ should not be affirmed as a true formula by the algorithm and, importantly, the clear source of the error is that the algorithm *failed to discover* that the second ‘disjunct’ was *nonsense*.¹⁰

Meaningfulness as well-formedness also gives an account of possibility similar to that expressed in Zimmerman’s free choice disjunction. In a very weak sense, a formula’s being well-formed is a kind of possibility. While, *e.g.*, the likelihood of a system evaluating $\lceil p \dot{\wedge} \dot{\neg} \rceil$ as 1 and that of its evaluating $\lceil p \dot{\wedge} \dot{\neg} \rceil$ as 1 are equal, there is still a sense in which

¹⁰To this, one might object that it would not be incoherent to evaluate a ‘statement’ of the form ‘The half life of uranium-238 is approximately 4 billion years, or or or and’ as true. From a phenomenological perspective, human beings encounter language not *in toto* but in a stream. Hence, it is plausible to suggest the evaluation of complex statements by human agents resembles the ‘lazy,’ McCarthy-style paradigm more closely than it resembles the Boolean picture.

the former is *more possible* than the latter. When we draw the conclusion that $\lceil p \wedge \neg p \rceil$ is unsatisfiable, we at least know what it *would* be for a valuation to map it to the truth.

For example, when determining that $A \wedge \neg A$ is false by use of indirect proof, it is necessary that we recreate the steps that *would* be necessary for its truth. We know that were $A \wedge \neg A$ true, both A and $\neg A$ would be true and judge this to be impossible; but this procedure only makes sense against some dim understanding of what conditions its truth *would* presuppose. But no such story is available for the string $\lceil A \wedge \neg \rceil$; if we try to rehearse the procedure on this string, we are faced with evaluating the semantical value of the symbol ‘ \neg .’

To sharpen this point, we observe that on the nonsense-as-ill-formedness reading any procedure evaluating such formulae necessarily maintains some procedure by which each component of the formula is surveyed. Although the algorithm in Figure 3 is clearly an oversimplification, it underscores that without such a resource, *e.g.*, McCarthy’s procedure in some cases is unable to distinguish between $\lceil p \dot{\vee} q \rceil$ and $\lceil p \dot{\vee} \dot{\vee} \rceil$. There must *exist* some active process that provides an assurance that the formula is meaningful, whether this process is psychological or mechanical. In general, that a formula A is epistemically possible, as free choice disjunction requires, is read as an existential statement, *i.e.*, that an alternative or scenario exists according to which A obtains. This is apparent in, *e.g.*, Hintikka’s analysis of the operator \mathbf{P}_a corresponding to epistemic possibility with respect to an agent a . In regard to a ‘model set’ μ —a consistent set of formulae representing a knowledge state—Hintikka outlines the intuitive condition:

If $\mathbf{P}_a p \in \mu$ then there is at least one alternative μ^* to μ , (with respect to a) such that

$$p \in \mu^*. (107, \text{ p. } 34)$$

If we allow that well-formedness yields a weak kind of possibility, the analogy can thus be extended to provide an analogue of this existential aspect: The existence of a procedure

actively checking and affirming the well-formedness of a variable or subformula is akin to the existence of an epistemic scenario witnessing the intelligibility or possibility of some formula.

4.3.2 Declaration of Variables

We find precisely such a species of possibility in the theory of computation. In defining an *environment*, we note that the environment is responsible for ensuring the *possibility* of semantical interpretations of syntactical symbols. Abelson and Sussman describe this in (2, p. 8) in the following terms:

It should be clear that the possibility of associating values with symbols and later retrieving them means that the interpreter must maintain some sort of memory that keeps track of the name-object pairs. This memory is called the *environment*.

A necessary condition for the possibility of a symbol's having meaning is that there be some process in the environment associating the syntactical object with a meaning. Note that this type of possibility is existential in nature, just as Hintikka's definition of epistemic possibility. In order for A to be possible in this weak sense, there must exist a resource allocated by the interpreter tasked with its interpretation.

More importantly, we find that this notion of possibility is precisely aligned with the notion of *meaningfulness*:

In an interactive language such as Lisp, it is meaningless to speak of the value of an expression such as $(+ x 1)$ without specifying any information about the environment that would provide a meaning for the symbol x . (2, p. 11)

In practice, the guarantee that some atom is possible is secured by the commands to *declare* or *initialize* a variable.

```

procedure DECLARATION( $y$ )
  boolean  $p \leftarrow 1$ 
   $x \leftarrow (p \text{ or } q)$ 
end procedure

```

Figure 4.4: Algorithm with Undeclared Variables

In, *e.g.*, C++, in order to render some syntactical object p usable as a Boolean variable, one must inform the interpreter that p is to be used in this manner. When the program is run, an instruction will be made allocating sufficient memory for p to take a value. To *declare* the Boolean variable p is to allocate the necessary resources; to *initialize* the Boolean variable is to declare it and simultaneously assign it a value. Without a variable being declared, it is *meaningless*; even if a formula is well-formed, if its atomic variables have not yet been declared, it is no more serviceable than an ill-formed string of symbols.

The distinction between declaring a variable and initializing a variable also has an *a priori* connection to the notion of possibility implicit in free choice disjunction. In the former case, memory is merely allocated for the variable; in the latter, not only is the memory allocated but it is also *employed* by assigning an initial value to the variable. In other words, while initializing the variable gives an evaluation, declaring the variable merely ensures the *possibility* of an evaluation.

Let us examine the fate of the Principle of Addition by considering a program, represented by the pseudocode in Figure 4.4. The algorithm is trivially a function of y but operates by *initializing* the Boolean variable p with the value 1 before proceeding to return the value of $p \text{ or } q$, where ‘or’ denotes logical (*i.e.*, Boolean) disjunction.

When this algorithm is run, the compiler will arrive at the symbol q and not know how to respond, yielding an error. q , having not been declared, is merely a symbol like any other. Hence, the program will terminate with a value of 1 occupying the memory set aside for the Boolean variable p although it will not return a value of 1 with respect to $p \text{ or } q$. What this means is that Addition is not valid in this setting.

4.3.3 Three Concrete Cases

The possibility-as-declaration-of-a-variable picture yields an interesting, if naïve, interpretation of a number of containment logics already in the literature. Before proceeding to this, however, we take a detour to define what will be called *Belnap variables*.

A Boolean variable may in principle be assigned only a value of either 1 or 0, corresponding to truth (**t**) and falsity (**f**), respectively, although the fact that a variable may be declared without being initialized suggests a *de facto* third value. In Section 4.1.2, we defined semantic consequence for the first-degree system E_{fde} , whose set of truth values is $\{\mathbf{t}, \mathbf{b}, \mathbf{n}, \mathbf{f}\}$. The semantical approach to this system and its values is given a robust interpretation in (23) and (24) which serves to generalize the notion of a Boolean variable.

Belnap worries about a computer receiving contradictory data from distinct sources, *e.g.*, two sensors reporting irreconcilable states of affairs to the system. Classically, such a situation would be trivializing, that is, it would render *every* piece of data unusable. Belnap, however, rightly suggests that a malfunctioning sensor should not interfere with, for instance, the arithmetical operations of the system. As a solution, Belnap considers values beyond merely **t** and **f**: the value **b**, *i.e.*, ‘both true and false’ and the value **n**, *i.e.*, ‘neither true nor false.’

Belnap anticipates the objection that formulae cannot *in reality* be both true and false by taking an explicitly *epistemic* approach. While one might not be able actually to *know* that a formula is both true and false, one can certainly be *told* that the formula is both true and false, and can indeed receive these reports from sources regarded as equally reliable. Belnap’s position, as related in (24), is that ‘the answer does not have the ontological force, “That’s the way the world is,” but rather the epistemic force, “That’s what I’ve been told (by people I trust to get it generally right)”.’

Define a *Belnap variable* to be a variable accepting the Belnap-like values so that any

procedure may only *increase* or *leave untampered* the variable's information rather than *decrease* it, that is, so the variable can not be *cleared*. This is in keeping with the Belnapian paradigm in (23), in which a computer is in a sense the passive recipient of data accumulating over time. A naïve interpretation immediately follows from the demand that a formula B is a consequence of Γ *iff* in every program with Boolean variables terminating so that $A \in \Gamma$ has a value of 1, B is valued as 1. While such an interpretation fails to enjoy the Proscriptive Principle—and is thus not a conceptivist system—it does suggest a semantical approach to other systems.

A few complications of this scheme immediately yield new interpretations for conceptivist systems already present in the literature. We will introduce three consequence relations the semantics of which are given in terms of programs with respect to sets of formulae $\Gamma \subseteq \mathcal{L}$ and formulae $A \in \mathcal{L}$. The first involves programs for systems employing Boolean variables:

Definition 4.3.2. $\Gamma \Vdash_1^* A$ *iff there exists a program employing Boolean variables terminating with all $B \in \Gamma$ assigned a designated value and for all such programs, upon termination A is assigned a designated value.*

The second relation is defined for programs employing Belnap variables that introduce values only by initialization, *i.e.*, in which one must assign a value to a variable upon declaring it.

Definition 4.3.3. $\Gamma \Vdash_2^* A$ *iff for all programs employing Belnap variables introduced only by initialization, if the program terminates with all $B \in \Gamma$ assigned a designated value, then A is assigned a designated value.*

Of course, in practice, one can declare a variable p without initializing it. If this is considered, we can define a further relation:

Definition 4.3.4. $\Gamma \Vdash_3^* A$ *iff for all programs employing Belnap variables, if the program terminates with all $B \in \Gamma$ assigned a designated value, then A is assigned a designated value.*

Now, if we consider the first-degree systems surveyed in Section 4.1.2, we find that the above relations, defined in terms of programs, correspond to the consequence relations for RC , S_{fde} , and S_{fde}^* , respectively.

We will now proceed to prove these equivalences:

Observation 4.3.1. $\Gamma \Vdash_1^* A$ iff $\Gamma \vDash_{\text{RC}} A$

Proof. Recall from Section 4.1.2 that Johnson’s conceptivist propositional calculus RC enjoys the property that

$$\Gamma \vDash_{\text{RC}} A \text{ iff } \begin{cases} \text{Con}(\Gamma), \\ \Gamma \vDash_{\text{CL}} A, \text{ and} \\ \mathbf{At}(A) \subseteq \mathbf{At}[\Gamma] \end{cases} .$$

We can employ this analysis to prove this observation.

For right-to-left, suppose that $\Gamma \vDash_{\text{RC}} A$. Then, from $\text{Con}(\Gamma)$, there exists a classical valuation v such that $v(B) = \mathbf{t}$ for all $B \in \Gamma$. Such a valuation can clearly serve as the basis for a program with Boolean variables assigning all formulae in Γ a value of 1 by initializing each $p \in \mathbf{At}[\Gamma]$ and assigning appropriate values. Moreover, in any such program, that $\Gamma \vDash_{\text{CL}} A$ ensures that the value of A will be 1. Hence, we reason that $\Gamma \Vdash_1^* A$.

For left-to-right, suppose that $\Gamma \Vdash_1^* A$. Then from the existence of a program π such that all formulae in Γ are assigned a value of 1, we can recover a classical valuation v witnessing that $\text{Con}(\Gamma)$. Moreover, $\Gamma \Vdash_1^* A$ entails that $\Gamma \vDash_{\text{CL}} A$. Suppose for contradiction that $\Gamma \not\vDash_{\text{CL}} A$. Then there exists a valuation v' such that $v'(B) = \mathbf{t}$ for each $B \in \Gamma$ while $v'(A) = \mathbf{f}$. But the equivalence of Boolean operations and classical truth functions entails that from v' we could write a program assigning all $B \in \Gamma$ a value of 1 while assigning A a value of 0, contradicting that $\Gamma \Vdash_1^* A$.

Finally, we can observe that this entails that $\mathbf{At}(A) \subseteq \mathbf{At}[\Gamma]$. Suppose that $\Gamma \Vdash_1^* A$ holds although $\mathbf{At}(A)$ contains a variable p not appearing in any formula in Γ . Then let π be the

program witnessing the satisfaction of both Γ and A and let π' be that program that differs from π only in not declaring p . Then each $B \in \Gamma$ will receive a value of 1 in π' although attempting to retrieve a value for A will result in error.

On the basis of $\Gamma \Vdash_1^* A$, we have proven each of the three conditions that are together equivalent to $\Gamma \models_{\text{RC}} A$.

□

Observation 4.3.2. $\Gamma \Vdash_2^* A$ iff $\Gamma \models_{\text{S}_{\text{fde}}} A$

Proof. We first recall some observations concerning S_{fde} . We may recall that Observation 4.1.2 shows that S_{fde} consequence is equivalent to LP consequence in conjunction with the criterion that all atoms appearing in the succedent formula appear in the set of assumptions. Moreover, by the semantics described in Definition 2.3.5, we may observe that LP is the restriction of E_{fde} to the values $\{\mathbf{t}, \mathbf{b}, \mathbf{f}\}$. By the foregoing discussion, E_{fde} is the logic by which Belnap variables operate.

Now, for left-to-right, suppose that $\Gamma \Vdash_2^* A$. As we are employing Belnap variables, this entails that $\Gamma \models_{\text{E}_{\text{fde}}} A$ and, as a subsystem of LP, this entails that $\Gamma \models_{\text{LP}} A$. To show that this entails that $\mathbf{At}(A) \subseteq \mathbf{At}[\Gamma]$, suppose that there exists a variable $p \in \mathbf{At}(A)$ not appearing in any formula in Γ . As there is an E_{fde} valuation that maps all formulae to a designated value, $\Gamma \Vdash_2^* A$ does not hold vacuously and there exists a program π terminating with all formulae in $\Gamma \cup \{A\}$ assigned a designated value. Consider a program π' differing from π only by deleting the line declaring the variable p . As p does not appear in any $B \in \Gamma$, Γ will take a designated value but A will not be evaluated as the system will not be able to retrieve a value for p . Hence, $\mathbf{At}(A) \subseteq \mathbf{At}[\Gamma]$. The observation above guarantees that these two conditions entail that $\Gamma \models_{\text{S}_{\text{fde}}} A$.

For right-to-left, suppose that $\Gamma \models_{\text{S}_{\text{fde}}} A$, *i.e.*, both $\Gamma \models_{\text{LP}} A$ and $\mathbf{At}(A) \subseteq \mathbf{At}[\Gamma]$, and suppose for contradiction that $\Gamma \not\Vdash_2^* A$. The latter condition entails that there be a program

π terminating with all $B \in \Gamma$ assigned a designated value, but A *not* be assigned a designated value. That all formulae in Γ are assigned designated values must entail that all variables in $\mathbf{At}[\Gamma]$ have been initialized and this, in conjunction with the assumption that $\mathbf{At}(A) \subseteq \mathbf{At}[\Gamma]$, entails that all variables appearing in A have likewise been initialized. Hence, the values of all formulae in Γ and that of A form a subset of $\{\mathbf{t}, \mathbf{b}, \mathbf{f}\}$. But this assignment corresponds to an $\mathbf{E}_{\mathbf{fde}}$ valuation restricted to $\{\mathbf{t}, \mathbf{b}, \mathbf{f}\}$, which is precisely an LP valuation, whence $\Gamma \not\models_{\text{LP}} A$, contradicting the assumption that this is valid in LP. \square

Observation 4.3.3. $\Gamma \Vdash_3^* A$ iff $\Gamma \models_{\mathbf{S}_{\mathbf{fde}}^*} A$

Proof. The proof runs virtually identically to that of Observation 4.3.2 except for associating the truth value \mathbf{n} with the state of a variable when it is declared but not yet assigned a value. \square

Despite admitting this computational interpretation, $\mathbf{S}_{\mathbf{fde}}$ is introduced as a conceptivist logic, in particular, as a means to repair some perceived shortcomings with Parry's $\text{PAI}_{\mathbf{fde}}$. We can stop to consider $\mathbf{S}_{\mathbf{fde}}$ —and $\mathbf{S}_{\mathbf{fde}}^*$ —in more detail and suggest that such systems present a reasonable first step towards reconciling the *prima facie* unrelated notions of meaningfulness and possibility with conceptivist systems.

First, if we examine the matrices for $\mathbf{S}_{\mathbf{fde}}$ or $\mathbf{S}_{\mathbf{fde}}^*$, we note that these systems obey the doctrine of the predominance of the atheoretical element and thus admit a reading similar to that which we gave to Σ_0 . Indeed, each is a subsystem of Bochvar's logic, as can be confirmed by noting that the $\mathbf{S}_{\mathbf{fde}}$ matrices restricted to $\{\mathbf{t}, \mathbf{f}, \mathbf{u}\}$ are the Σ_0 matrices.

More importantly, disjunction in $\mathbf{S}_{\mathbf{fde}}$ and $\mathbf{S}_{\mathbf{fde}}^*$ also exhibits behavior approximating Zimmerman's notion of free choice disjunction. Let $\mathcal{D}_{\mathbf{S}_{\mathbf{fde}}} = \{\mathbf{t}, \mathbf{b}\}$, the set of designated values of $\mathbf{S}_{\mathbf{fde}}$. By examining the matrices we note that for appropriate valuations v , $v(A \dot{\vee} B) \in \mathcal{D}_{\mathbf{S}_{\mathbf{fde}}}$ if $f_P^{\dot{\vee}}(v(A), v(B)) \in \mathcal{D}_{\mathbf{S}_{\mathbf{fde}}}$. But parsing the intension of $f_P^{\dot{\vee}}$ is interesting in that, as we saw in the work of Zimmerman and Fitting, there is an unavoidable use of conjunction.

Then

$$v(A \dot{\vee} B) \in \mathcal{D}_{\mathbf{S}_{\text{fde}}} \text{ iff } \begin{cases} v(A) \in \mathcal{D}_{\mathbf{S}_{\text{fde}}} \text{ or } v(B) \in \mathcal{D}_{\mathbf{S}_{\text{fde}}}, \text{ and} \\ v(A) \neq \mathbf{u}, \text{ and} \\ v(B) \neq \mathbf{u} \end{cases}$$

Assuming the intuitive readings of ‘ $v(A) \in \mathcal{D}_{\mathbf{S}_{\text{fde}}}$ ’ as ‘ A is the case’ and ‘ $v(A) \neq \mathbf{u}$ ’ as ‘ A might be the case,’ we find that the above mirrors Zimmerman’s free choice disjunction perfectly, *i.e.*,

$$v(A \dot{\vee} B) \in \mathcal{D}_{\mathbf{S}_{\text{fde}}} \text{ iff } \begin{cases} \text{either } A \text{ is the case or } B \text{ is the case, and} \\ A \text{ might be the case, and} \\ B \text{ might be the case} \end{cases}$$

\mathbf{S}_{fde} thus gives us an example of a conceptivist logic that can be motivated on computational, rather than Kantian, grounds. Moreover, by amending the notions of ‘meaningfulness’ and ‘possibility’ to render them suitable to a computational setting, \mathbf{S}_{fde} also unifies the insights underlying a pair of very distinct semantical traditions.

We thus see how tracing a computational theme yields a conceptivist logic

- a. that is a subsystem of a nonsense logic (and is thus itself a nonsense logic) and
- b. whose account of disjunction mirrors that of free choice disjunction.

Although naïve, the ‘declaration of variables’ interpretation is able to bring these disparate rejections of Addition under one roof.

4.4 Enriching the Interpretation

A clear limitation of the naïve account of declaration of variables as outlined above is that it is static and gives only a snapshot of the state of some program. But computation is

not static; there are dynamic and temporal aspects of computation that were necessarily suppressed in the foregoing discussion.

If we are to further develop the theme of reading conceptivist systems as having a salient interpretation for computing, it will be fruitful to consider systems capable of respecting this dynamism. This section intends to take some initial steps into doing just this by considering systems that enrich the declaration-of-variables picture with dynamic and temporal apparatus.

4.4.1 Conceptivism and Propositional Dynamic Logic

Propositional dynamic logic (PDL) is a multi-modal system of propositional logic in which the \Box and \Diamond operators of modal logic are given explicit interpretations— $[\alpha]$ and $\langle\alpha\rangle$ —where α is interpreted as either a program or an action. Following Harel, Kozen, and Tiuryn in (105), the interpretation of $[\alpha]A$ for a PDL formula A is ‘every execution of the program α yields a state in which A is true.’ The dual connective $\langle\alpha\rangle$ is read so that $\langle\alpha\rangle A$ is interpreted as ‘there exists some execution of α terminating in a state at which A is true.’ (The reading in terms of actions is easily recovered from these interpretations.)

The syntax of PDL allows a number of operations on programs within the scope of the brackets. Programs are built up from a set of atomic programs $\mathbf{At}_\Pi = \{a, b, c, \dots\}$ so that the set of programs Π is constructed recursively:

- If $a \in \mathbf{At}_\Pi$ then $a \in \Pi$
- If $\alpha \in \Pi$ then $\alpha^* \in \Pi$
- If $\alpha, \beta \in \Pi$ then $\alpha; \beta \in \Pi$ and $\alpha \cup \beta \in \Pi$

α^* represents a program that nondeterministically selects a finite n and executes program α n many times, while program $\alpha; \beta$ is the program executing α followed by β .

Of present importance is the operator \cup so that to execute the program $\alpha \cup \beta$ is to ‘choose either α or β nondeterministically and execute it.’ In terms of actions, this clearly has a reading of freely choosing to perform either α or β . An anonymous referee for the *Journal of Applied Non-Classical Logics* has suggested a *prima facie* connection between the distribution of a modal operator over disjunction—that the possibility of a disjunction entails the possibility of each disjunct—and propositional dynamic logic, notably the axiom

$$[\alpha \cup \beta]A \leftrightarrow [\alpha]A \wedge [\beta]A$$

There are two things that can be said of this apparent connection.

Intriguingly, a connection between the problem of free choice permission and PDL has been investigated by Robert van Rooij in the paper (190). In part, van Rooij diagnoses the difficulty in inferring $\diamond(A) \wedge \diamond(B)$ from $\diamond(A \dot{\vee} B)$ as an artifact of the possible worlds reading of propositions. That is, if X is a nonempty set of possible worlds at which $A \dot{\vee} B$ holds, then this clearly does not entail the existence of any worlds at which, *e.g.*, B holds. However, van Rooij cites a different approach to the interpretation of deontic modals:

Another tradition... is based on the assumption that deontic concepts are usually applied to *actions* rather than propositions.(190, p. 5)

In essence, van Rooij’s solution is to add an atomic proposition Per representing all ‘permissible worlds.’ Then, $[\alpha]\text{Per}$ (which van Rooij symbolizes ‘ $\text{Per}(\alpha)$ ’) means that any execution of action (*i.e.*, program) α leads to a permissible state of affairs.

Then, substituting the proposition Per for A , we yield

$$[\alpha \cup \beta]\text{Per} \leftrightarrow [\alpha]\text{Per} \wedge [\beta]\text{Per},$$

as a theorem of PDL. This instance suggests the desired reading that if a random selection between actions α and β each lead to a permissible state of the world, then individually, both α and β will lead to such a state.

However, independently of the matter of free choice disjunction, the reading of a term α as a program is independently interesting inasmuch as it suggests a direct application of Parry's syntactic concerns. One cannot, for example, add a new syntactical element, such as an arbitrary line of code, to a program without concern for its meaningfulness.

In one sense, PDL fulfills the spirit of Parry's remarks. When terms α are interpreted as programs, there is a sense in which PDL resists the notion of error-free introduction of arbitrary syntax. For example, consider the theorem of PDL

$$\langle \alpha \rangle A \rightarrow \langle \alpha \cup \beta \rangle A$$

At first blush, it may appear that this is a *violation* of the spirit of the Proscriptive Principle, as the fact that a particular program α has a property (that some instance of its computation yields a state at which A is true) entails that some *further* program $\alpha \cup \beta$ —where β is arbitrary, perhaps even nonsensical or error-ridden—has this property. Upon closer inspection, however, all that this means is *some instance* of the program $\alpha \cup \beta$ yields A , namely, the instance witnessed by the antecedent $\langle \alpha \rangle A$.

PDL, in fact, seems to have a built in ability to throw away syntactically ill-formed programs. The formula

$$[\alpha]A \rightarrow \langle \alpha \rangle A$$

fails to be a PDL-theorem, whence one can infer that merely because one can *write* a program does not mean that it can be *executed*.

There is, however, tension between some of the observations made in Section 4.3.3 and the peculiarities of PDL. Consider, for example, that the natural language interpretation of the formula

$$[\alpha]A \rightarrow [\alpha](A \dot{\vee} B)$$

is that for an arbitrary program α , if any execution of α results in a state at which A is true, then any execution of α will also result in a state at which $A \dot{\vee} B$ is true. As the ‘local’ logic of the models is classical, *i.e.*, the Principle of Addition holds locally at every state w , this is clearly a theorem of PDL. It is also one which the present considerations seem to contradict.

For example, we noted that one can consider a program π whose sole operation is to initialize a variable p with a value of 1. If one were to make two amendments to π by adding code to recover the value of p and to recover the value of p **or** q (where ‘**or**’ is the disjunction from the algorithm), respectively, the first amended program would report that p has a value of 1 while the second would report an error. π seems to witness that there are programs the execution of which yields a state such that p is true—assigned a value of 1—while $p \dot{\vee} q$ is not.

If this is rephrased in the language of propositional dynamic logic, this is analogous to the statement that

$$\dot{\neg}([\pi]p \rightarrow [\pi](p \dot{\vee} q))$$

This is apparently a counterexample to the PDL theorem in question.

There seem to be ready-to-hand ways of addressing this matter in PDL. If, for example, one builds into PDL a definition so that

$$\mathbf{At}(\alpha) =_{df} \{p \in \mathbf{At} \mid p \text{ is declared in } \alpha\},$$

then one candidate account of the operator $[\alpha]$ may read:

$$w \Vdash [\alpha]A \text{ if } \begin{cases} \text{at all } w' \text{ such that } wR_\alpha w', w' \Vdash A, \text{ and} \\ \mathbf{At}(A) \subseteq \mathbf{At}(\alpha) \end{cases}$$

Clearly, the formula $[\alpha]A \rightarrow [\alpha](A \dot{\vee} B)$ will not be a theorem of such a weakened subsystem of PDL. This appears to be a plausible and conceptually sound revision of PDL respecting the matter of declaration of variables.

There are a number of subtle questions with respect to how such a system is to be formalized and axiomatized. For example, if programs α and β each declare the variable p , then how should the program $\alpha; \beta$ —the program executing α and then executing β —be analyzed? One could arguably reject $\alpha; \beta$ as ill-formed, answering this question at the level of syntax. Alternatively, one could either treat the declaration of p in β as redundant or treat it as clearing the variable. Exploring such questions could take up an entire chapter; for present purposes, it must suffice to raise these questions and identify them as interesting.

4.4.2 An Intuitionistic Conceptivist Logic

The connection between intuitionistic logic and computation is well-known. By means of the Curry-Howard correspondence, provability of a formula A in the implicative fragment of intuitionistic logic corresponds to the existence of a program or function in the λ -calculus of type A . Similar correspondences exist between other propositional logics and classes of programs or computable functions; for example, the provability of A in \mathbf{R}_{\rightarrow} —the pure implicative fragment of relevant logic \mathbf{R} —corresponds to the class of $\lambda\mathbf{I}$ -terms. (179) provides a very good discussion of this correspondence, as well as many other such correspondences.

This computational picture is reinforced by the Kripke semantics for intuitionistic logic first introduced in (124), in which points w in a model can be thought of as states and moving forward along an accessibility relation R can be read as the evolution of a computational procedure. Kripke's semantical picture is *prima facie* equally well-suited to account for the declaration of variables as well; one can imagine not only processes evolving and calculating values but also declaring syntax over the course of these evolutions. As we will see in this section, doing so yields a conceptivist system.

A basis for such an approach can be found in a program begun by Peter Woodruff of producing intuitionistic subsystems of many-valued logics in (198). The techniques of his dissertation are brought to bear on Halldén's \mathbf{C} in (199), in which constructive subsystems

are provided for \mathbf{C} and Krister Segerberg's \mathbf{D} , a further logic of nonsense described in (172). The ensuing constructive systems are called \mathbf{CI} and \mathbf{DI} , respectively. \mathbf{CI} essentially exports Halldén's intuitions about nonsense and applies them to Kripke's models for intuitionistic logic.

By some simple revisions of Woodruff's definitions, the system \mathbf{CI} can be further adapted to provide constructive subsystems of Bochvar's Σ and Σ_0 that admit the very reading we are after. Inasmuch as the following technique will yield a fragment of Σ_0 that qualifies as a containment logic, we can think of this section as providing a third 'strategy' to complement the two strategies described in Chapter 2, *i.e.*, taking connexive and paraconsistent fragments.

We will first review Woodruff's semantics for \mathbf{CI} .

Definition 4.4.1. *A \mathbf{CI} model is a 4-tuple $\langle W, R, V_T, V_M \rangle$ such that*

- W is a nonempty set of points
- R is a reflexive and transitive binary relation on W
- $V_T : \mathbf{At} \rightarrow \wp(W)$ with the condition that if $w \in V_T(p)$ and wRw' then $w' \in V_T(p)$
- $V_M : \mathbf{At} \rightarrow \wp(W)$ with the condition that if $w \in V_M(p)$ and wRw' then $w' \in V_M(p)$
- for all $p \in \mathbf{At}$, $V_T(p) \subseteq V_M(p)$

From these, a pair of forcing relations are defined in tandem.

As we will ultimately be interested in a pure implicational fragment of this system, we will provide truth conditions only for formulae in the pure implicational language $\mathcal{L}_{\rightarrow}$, that is, the collection of propositional formulae in which no connective but \rightarrow appears. To make things precise, we define $\mathcal{L}_{\rightarrow}$:

Definition 4.4.2. *The propositional language $\mathcal{L}_{\rightarrow}$ is recursively defined so that*

- If $p \in \mathbf{At}$ then $p \in \mathcal{L}_{\rightarrow}$
- If $A, B \in \mathcal{L}_{\rightarrow}$ then $A \rightarrow B \in \mathcal{L}_{\rightarrow}$

As we are restricting our attention to a pure implicational language, we will define the relevant semantic relations only for members of $\mathcal{L}_{\rightarrow}$:

Definition 4.4.3. *Meaningfulness of a formula A at a point w in a model \mathcal{M} , symbolized by $\mathcal{M}, w \Vdash_M A$ is defined so that:*

- $\mathcal{M}, w \Vdash_M p$ if $w \in V_M(p)$
- $\mathcal{M}, w \Vdash_M A \rightarrow B$ if $\mathcal{M}, w \Vdash_M A$ and $\mathcal{M} \Vdash_M B$

Truth of a formula A is similarly defined:

- $\mathcal{M}, w \Vdash_T p$ if $w \in V_T(p)$
- $\mathcal{M}, w \Vdash_T A \rightarrow B$ if $\begin{cases} \forall w' \text{ such that } wRw', \text{ if } \mathcal{M}, w' \Vdash_T A, \text{ then } \mathcal{M}, w' \Vdash_T B, \text{ and} \\ \mathcal{M}, w \Vdash_M A \rightarrow B \end{cases}$

Validity for the intuitionistic system **CI** is defined by the following scheme.

Definition 4.4.4. $\Gamma \vDash_{\mathbf{CI}} A$ iff for all models \mathcal{M} and points w , if $\mathcal{M}, w \Vdash_T B$ for all $B \in \Gamma$ and $\mathcal{M}, w \Vdash_M A$, then $\mathcal{M}, w \Vdash_T A$

We wish to construct the analogous system for an intuitionistic version of Bochvar's logic, but Woodruff's semantics does not make use of truth values. If it is a dispute concerning truth values that distinguishes the accounts of Bochvar and Halldén, it may not be immediately clear how to adapt Woodruff's semantics to a system harmonious with Bochvar's intuitions.

Recall from Section 3.3.3 that Halldén is adamant that designation of the nonsense value is not to say that nonsense is truth-like in any way, but rather, to say that validity is only

concerned with cases in which the consequent is meaningful. This is, in effect, to say that one should never reject an entailment $\Gamma \vdash A$ by producing a counterexample in which A is nonsense. Woodruff's qualification that $\Gamma \vDash_{\text{Cl}} A$ is only evaluated in occasions at which A is meaningful aligns it with Halldén's taking the nonsense truth value as designated.

This is the difference between the internal calculi of Bochvar and Halldén in a nutshell. We can thus describe a system ΣI that bears the same relationship to Cl that Σ bears to C . We merely revise the definition of validity so that:

Definition 4.4.5. $\Gamma \vDash_{\Sigma\text{I}} A$ iff for all models \mathcal{M} and points w , if $\mathcal{M}, w \Vdash_T B$ for all $B \in \Gamma$, then $\mathcal{M}, w \Vdash_T A$

Clearly, this furthermore determines a constructive subsystem of Bochvar's Σ_0 when the connective ' \rightarrow ' is identified with Bochvar's internal implication.

Just as Σ_0 is not \vdash -Parry, neither is ΣI_0 , and for identical reasons. Inasmuch as $A \dot{\wedge} \dot{\vee} A$ can never be true at a point w , $A \dot{\wedge} \dot{\vee} A \vDash_{\Sigma\text{I}_0} B$ will vacuously hold. On the other hand, inasmuch as a contradiction cannot be expressed without negation, every formula in the pure implicational fragment of ΣI has a model. Inferences concerning any formulae in *this* language will enjoy the Proscriptive Principle with respect to \vdash . Importantly, $\Sigma\text{I}_{\rightarrow}$ —the implicational fragment of ΣI —will be \vdash -Parry.¹¹

Intuitively, the semantical picture admits a reading in which variables are declared at certain stages in a computation. Consider, for example, a $\Sigma\text{I}_{\rightarrow}$ model whose frame is a tree with a root node w . Suppose that $w \Vdash_M p$ holds in the model; this can be read as p being *globally* declared by the main procedure w , as all subsequent points recognize p as meaningful. If, on the other hand, some atom q is not meaningful at w , but there exists a distinct w' such that wRw' and $w' \Vdash_M q$, then one can interpret w' as a subprocedure called by w that *locally* declares q . Calculations made outside of this subprocedure—*i.e.*, outside

¹¹Note that this suggests that the two strategies for defining conceptivist subsystems of Σ_0 described in Section 2.3—that is, by taking connexive or paraconsistent fragments—are joined by a third strategy.

of the upwards R -cone of w' —will not necessarily be able to employ q .

The implicational system Σ_{\rightarrow} admits a simple natural deduction proof theory. Consider the following definition.

Definition 4.4.6. *The natural deduction calculus for Σ_{\rightarrow} is defined by the rules:*

$$\begin{array}{c}
 [Ax] \quad A \vdash A \text{ is an axiom.} \\
 [Str] \quad \frac{\Gamma, \Gamma' \vdash B}{\Gamma, A, \Gamma' \vdash B} \quad [Con] \quad \frac{\Gamma, A, A, \Gamma' \vdash B}{\Gamma, A, \Gamma' \vdash B} \quad [Exc] \quad \frac{\Gamma, A, C, \Gamma' \vdash B}{\Gamma, C, A, \Gamma' \vdash B} \\
 [\rightarrow I] \quad \frac{\Gamma, A \vdash B}{\Gamma \vdash A \rightarrow B} \text{ provided that } \mathbf{At}(A) \subseteq \mathbf{At}[\Gamma] \\
 [\rightarrow E] \quad \frac{\Gamma \vdash A \rightarrow B \quad \Gamma \vdash A}{\Gamma \vdash B}
 \end{array}$$

As expected, this system is indeed a conceptivist calculus.

Observation 4.4.1. Σ_{\rightarrow} is \vdash -Parry

Proof. This follows from a simple induction on the lengths of proofs. All axioms clearly satisfy the Proscriptive Principle for \vdash . In each of the inference rules, it can be directly observed that this property is inherited by each succeeding application of a rule. Hence, all derivable sequents enjoy the property, whence Σ_{\rightarrow} is \vdash -Parry. \square

Completeness between the natural deduction calculus and the Woodruff-style semantics can be established by means of the canonical model technique. We will first define the canonical model for Σ_{\rightarrow} :

Definition 4.4.7. *The canonical model $\mathcal{S} = \langle W, R, V_T, V_M \rangle$ for Σ_{\rightarrow} is defined so that:*

- $W = \{\Gamma \mid \Gamma \text{ is a deductively closed } \Sigma_{\rightarrow}\text{-theory}\}$
- $R = \{\langle \Gamma, \Delta \rangle \mid \Gamma \subseteq \Delta\}$

For atoms p , we then set V_M and V_T so that:

- $V_M(p) = \{\Gamma \in W \mid \exists B \in \Gamma \text{ such that } p \text{ appears in } B\}$
- $V_T(p) = \{\Gamma \in W \mid p \in \Gamma\}$

That what we have defined is in fact a model in Woodruff's sense is not trivial; we must confirm that it enjoys the necessary properties.

Observation 4.4.2. \mathcal{S} is a model.

Proof. Clearly, $V_T \subseteq V_M$; that $p \in \Gamma$ trivially implies that each of its atoms is found in Γ .

That R is reflexive and transitive follows immediately from the properties of \subseteq . This also entails that both V_M and V_T are hereditary, *i.e.*, that if $w \in V_M(p)$ and wRw' then $w' \in V_M(p)$ and *mutatis mutandis* for V_T .

□

Lemma 4.4.1. $A \in \Gamma$ iff $\mathcal{S}, \Gamma \Vdash_T A$

Proof. In the case of atomic formulae p , the definition of V_T entails that $\Gamma \in V_T(p)$ iff $p \in \Gamma$. Hence, that $\Gamma \vdash_{\Sigma \rightarrow} p$ is equivalent to $p \in \Gamma$, which is by definition equivalent to $\Gamma \in V_T(p)$ which is just the definition for $\mathcal{S}, \Gamma \Vdash_T p$.

Now, we prove this for arbitrary formulae of the form $A \rightarrow B$. We will prove this by induction on complexity of formulae. Suppose for induction hypothesis that this has been shown to hold for all subformulae of $A \rightarrow B$.

For right-to-left, suppose that $\Gamma \vdash_{\Sigma \rightarrow} A \rightarrow B$. Then, as $A \rightarrow B \in \Gamma$, trivially all atoms in $A \rightarrow B$ appear in some $C \in \Gamma$, whence $\mathcal{S}, \Gamma \Vdash_M A \rightarrow B$. Moreover, by $(\rightarrow E)$, in any extension $\Gamma' \supseteq \Gamma$, if $A \in \Gamma'$ then $B \in \Gamma'$. By induction hypothesis, this is to say that for all Γ' such that $\Gamma R\Gamma'$, if $\mathcal{S}, \Gamma' \Vdash_T A$ then $\mathcal{S}, \Gamma' \Vdash_T B$. But this—with the observation that $\mathcal{S}, \Gamma \Vdash_M A \rightarrow B$ —entails that $\mathcal{S}, \Gamma \Vdash_T A \rightarrow B$.

Now, for left-to-right, suppose that $\mathcal{S}, \Gamma \Vdash_T A \rightarrow B$. We infer then that at every Γ' such that $\Gamma R\Gamma'$, if $\mathcal{S}, \Gamma' \Vdash_T A$ then $\mathcal{S}, \Gamma' \Vdash_T B$ which, by induction hypothesis, allows us

to infer that in any extension $\Gamma' \supseteq \Gamma$, if $\Gamma' \vdash_{\Sigma \mapsto} A$ then $\Gamma' \vdash_{\Sigma \mapsto} B$. This, however, does not immediately allow us to infer that $\Gamma \vdash_{\Sigma \mapsto} A \rightarrow B$; we need more work to show that $\mathbf{At}(A) \subseteq \mathbf{At}[\Gamma]$.

This work begins by noting that $\mathcal{S}, \Gamma \Vdash_M A \rightarrow B$, entailing that there exists some formula C such that both $\Gamma \vdash_{\Sigma \mapsto} C$ and $\mathbf{At}(A \rightarrow B) \subseteq \mathbf{At}(C)$. Hence, $C \in \Gamma$, from which we may make it explicit that to say that $\Gamma, A \vdash_{\Sigma \mapsto} B$ is equivalent to saying that $\Gamma, C, A \vdash_{\Sigma \mapsto} B$. Hence, as $\mathbf{At}(A) \subseteq \mathbf{At}(C)$, we are licensed to infer that $\Gamma, C \vdash_{\Sigma \mapsto} A \rightarrow B$. By the redundancy of C , however, we conclude that $\Gamma \vdash_{\Sigma \mapsto} A \rightarrow B$. \square

Theorem 4.4.1. *If $\Gamma \vDash_{\Sigma \mapsto} A$ then $\Gamma \vdash_{\Sigma \mapsto} A$.*

Proof. We prove the contrapositive. If $\Gamma \not\vdash_{\Sigma \mapsto} A$ then $A \notin \Gamma$. By Lemma 4.4.1, this entails that $\mathcal{S}, \Gamma \not\mathcal{K}_T A$, witnessing that $\Gamma \not\vDash_{\Sigma \mapsto} A$. \square

Theorem 4.4.2. *If $\Gamma \vdash_{\Sigma \mapsto} A$ then $\Gamma \vDash_{\Sigma \mapsto} A$.*

Proof. This can be established by induction on the length of proofs. In the basis step, note that all instances of axioms are semantically valid. All inferences in the natural deduction calculus can be easily seen to be validity-preserving. That this holds for every derivable $\Gamma \vdash_{\Sigma \mapsto} A$ follows by induction. \square

Although the picture is suggestive, there is still much to be developed concerning such a system. For example, inhabitation problems must be rephrased, as $\Sigma \mapsto$ has no theorems. Asking whether there is a function inhabiting such-and-such a formula only makes sense against the backdrop of a nontrivial environment.

But this is actually quite natural in this context. In the formulae-as-types paradigm, a set of premises Γ in a judgment is called the ‘environment.’ As we saw in (2), it is the environment that assigns meanings to symbols in computing. Hence, from an interpretative

standpoint, it is perfectly natural to expect that no inferences can be drawn from an empty environment as all symbols remain uninterpreted in such an environment.¹²

4.5 Conclusions

The interpretation of conceptivist logic offered above provides a way of examining some formal problems with respect to these systems, such as the matter of dealing with quantification and entailment connectives, that differs from the standard semantical interpretations of conceptivist systems. Moreover, it also is hoped that the computational approach to conceptivism might bear some practical fruit as well.

The aim of this discussion has been, in part, to rehabilitate Parry-type logics—and deductive systems rejecting Addition in general—by providing a natural and serviceable foundation for their intuitions and formalisms. Yet the utility of the present interpretation very likely goes beyond elucidating an obscure footnote in the history of logic. While Section 4.3.3 provides concrete interpretations of such systems, conceptivist systems may yield more general fruits as well.

The Belnap account of computing can address one sort of error or problem, that is, the matter of drawing inferences in the face of inconsistent data. Papers such as (43) are motivated by a particular instance of this problem: the inconsistent database. In general, as a matter of fact, paraconsistent systems *do* appear to be well-equipped to handle such circumstances. The considerations of this chapter suggest that there are further sources of error that must be addressed in such a database: beyond occasions in which a system retrieves inconsistent data lie the occasions in which a system is unable to retrieve any value at all.

Suppose, for instance, that we are employing a database constructed with E_{fde} as an

¹²*Cf.* (55), in which Daniels expresses the sentiment that ‘[i]t’s doubtful whether *any* sentence is true in all stories.’(55, p. 424)

underlying logic, just as Belnap suggests. Querying a database and retrieving Belnap's value of \mathbf{n} for some proposition is minimally informative in $E_{\mathbf{fde}}$, but this does not necessarily entail that the receipt of this value conveys no information at all. Belnap's epistemic interpretation of retrieving a \mathbf{n} value is that the sources have neither reported that the corresponding proposition is true nor have they reported that it is false. From this circumstance, however, it is reasonable to infer that the sources possess neither solid evidence in its favor nor a compelling counterexample; had the sources been in possession of this sort of evidence, *it would have been reported*. Concretely, the system knows that the sources *did not* submit positive or negative values. Hence, there is *something* to be learned from retrieving such a value.

In (92), Luciano Floridi gave an example that illustrates this distinction well. Floridi considered querying a database (in his case, the *Routledge Encyclopedia of Philosophy on CD-ROM*) for such-and-such a search term. In one case, '[i]f the database provides an answer, it will provide at least a *negative* answer, e.g., the [encyclopedia] will open a small window with the message "no search hits found".' This error imparts *negative information* to the end user. Distinct from this, however, is the case in which the database fails to reply to the query. It either 'fails to provide any data at all' or some additional process at least informs the end user that there is an error in the database. The truth values can be associated with this interpretation—truth with a positive hit on the search, falsity with a negative hit on the search, and the nonsense value with some process from the environment informing the user of some fault or other.

What, however, is there to be learned when the system queries the database only to find that there is an error, whether it is due to a variable not being declared or data being corrupted? A corrupted entry in a database provides strictly less information than having not received any entries. While from, for example, one of the truth values corresponding to those of $E_{\mathbf{fde}}$ one can infer something *negative*, if an entry is corrupted, or otherwise

irretrievable, all of these possibilities are *a priori* equipossible. E_{fde} is thus not able to model this scenario.

A conceptivist and paraconsistent system such as S_{fde} provides a way of accounting for each of these dimensions. For example, a database which includes instances of corrupted data and instances of data which are inconsistent with each other, will be best modeled by a system such as S_{fde} . Clearly, S_{fde} has some significant limitations. S_{fde} supports some inferences difficult to motivate in this context. For example, the inference $p \dot{\vee} q \vDash_{S_{fde}} q \dot{\vee} \dot{\neg} q$ is valid, which on the present reading suggests that the variable q 's being declared entails that it has been initialized. Daniels' system S_{fde}^* —which does not support this inference—may thus provide a better starting point. In any case, the computational interpretation of conceptivist logics in general yields a novel way of thinking about such matters.

What is more difficult is embellishing the philosophical aspect. At first blush, there is no connection between the work of Bochvar and Halldén on the one hand and Zimmerman on the other. Many epistemically impossible formulae, *e.g.*, $A \dot{\wedge} \dot{\neg} A$, are meaningful on the account of logics of nonsense; the work of Zimmerman is particularized to a single case of the problem of free choice permission, without any appeal to notions of meaningfulness. That these two, very distinct, formal approaches converge while interpreting a *third*, equally unrelated thesis of containment is quite curious. While this chapter does not definitively account for this phenomenon, further exploration of the coincidence of these three themes appears to be warranted.

In short, the treatment of conceptivist logic presented in this chapter raises as many questions as it solves and many matters of interpretation remain up for grabs. That said, the present interpretation demonstrates that there may still be some life in the conceptivist scheme and provides further evidence that the obituary Sylvan wrote for it might well have been premature.

Chapter 5

Faulty Belnap Computers and Subsystems of E_{fde}

In this chapter we consider variations of Nuel Belnap's 'artificial reasoner.' In particular, we examine cases in which the artificial reasoner is faulty, *e.g.*, we consider situations in which the reasoner is unable to calculate the value of a formula due to an inability to retrieve the values of its atoms. In the first half of the paper, we consider two ways of modeling such circumstances and prove the deductive systems arising from these two types of models to be equivalent to the Daniels-Priest system S_{fde}^* and Richard Angell's AC, making computational interpretations of these systems possible. The Belnap-type interpretation of AC yields a novel many-valued semantics for AC, bringing Angell's system in line with similar treatments of other *containment logics* in its neighborhood. The second half of the paper examines formal questions, such as whether AC admits an analysis along the lines of that given to the related system of William Parry's system of *analytic implication* (PAI), as suggested by Kurt Gödel and confirmed by Kit Fine. Furthermore, a natural means of extending these systems to languages with an intensional implication connective is investigated.

5.1 Introduction

In (23), Nuel Belnap outlines a prescription for how, in light of the practical problem of a computer's receiving contradictory data, a computer ought to 'think.' In particular, Belnap suggests that the inconsistency-tolerant logic of *first-degree entailment* (E_{fde}) can be fruitfully employed to deal with occasions in which such data were received. In this chapter, we will not take up the normative question of whether a computer *ought* to think as Belnap suggests; rather, for the sake of argument, we will assume that Belnap is correct. What we will consider is the question: *Given* that a computer ought to operate in this way, how *would* it operate? In particular, we consider a further deviation from theoretically pure computing: occasions in which the Belnap computer is unable to recover the value assigned to a variable.

Although the earlier presentation of E_{fde} in Definition 3.1.17 considers its semantic values to be individuals, the semantical values of E_{fde} can also be represented as a pair of data corresponding to a *truth* value and a *falsity* value. This representation suggests two reasonable implementations of a 'Belnap computer': a case in which the entire semantical value may be stored at a single address, and a case in which a Belnap variable requires distinct addresses for each coordinate. The cases in which faults in retrieval of the values occur will thus be called the 'single address' and 'two address' accounts, respectively. The logic determined by the 'single address' account is the Daniels-Priest system S_{fde}^* described in Definition 4.1.5. The logic of the 'two address' account is equivalent to Angell's system of *analytic containment* (AC). The semantics introduced in the present paper provide a perspective on AC differing from those described by Fabrice Correia in (50) or Kit Fine in (87). We will then shift focus to examine some consequences of the semantics described in this chapter.

The interpretation offered in this chapter has the benefit of providing AC and S_{fde}^* into alignment with other *containment logics*, allowing these systems to be extended to higher-degree logics in a natural fashion. In the case of AC, after introducing the present nine-valued

semantics (which will initially be denoted by ‘NC’), we will review the semantics introduced by Correia in (49) before showing the soundness and completeness of the present semantics to AC. We will then continue the inquiry by employing these semantics to give a deeper analysis of AC and S_{fde}^* , such as providing the Gödel-Fine analysis of AC. Finally, we adapt Fine’s semantics from (81) for William Parry’s intensional containment logic PAI to extend S_{fde}^* and AC to accommodate formulae in a language with nested arrows.

We begin by reviewing the first-degree systems.

5.2 Three First-Degree Logics

We examine three *first-degree* systems. Such systems are defined over the language \mathcal{L}_{zdf} that lack an intensional implication connective (although a material conditional \supset may be defined); their novelty lies in the correspondence between valid inferences of the form $A \vDash B$ in the first-degree case and valid theorems $A \rightarrow B$ in intensional cases, *i.e.*, in first-degree entailment E_{fde} , $A \vDash_{E_{fde}} B$ iff $A \rightarrow B$ is a theorem of Anderson and Belnap’s E, where A and B have no instances of the intensional entailment connective, *i.e.*, are *zeroth degree formulae*.

5.2.1 First-Degree Entailment E_{fde}

Belnap’s interpretation of E_{fde} of (23) and (24) plays a central role in the sequel and we will discuss Belnap’s artificial reasoner in more detail. Recall that Belnap describes both an interpretation and a proposed application of the four-valued logic of first-degree entailment in a computational setting. Belnap’s observation is that a computer—or ‘artificial reasoner’—obtains data from a variety of inputs and it is conceivable that the data from distinct and independent sources may be contradictory. For example, if a system sends a calculation for a Boolean variable A to two subprocedures to review in parallel and if a fault in one of the subprocedures leads it to an error in its calculation, the subprocedures may return

incompatible values for A . Absent a definitive indication concerning which subprocedure is in error, the system will have as good evidence for the value of A 's being 1 as it will for the value being 0.

Of course, in the classical propositional calculus, contradictory data in a theory trivializes the theory as arbitrary formulae may be deduced from a contradiction. Rather than allowing small, isolated inconsistencies to ‘pollute’ the entire ocean of data in this way, Belnap proposes the motto ‘Keep our data clean.’ E_{fde} , he suggests, is precisely the means by which this motto ought to be observed.

In Definition 3.1.17, we have introduced four-valued semantics for the system E_{fde} according to which $\mathcal{V}_{E_{\text{fde}}} = \{\mathbf{t}, \mathbf{b}, \mathbf{n}, \mathbf{f}\}$. However, an equally salient expression of the semantics does not interpret the set semantic values as independent and non-classical truth values, but rather construes them as *pairs* of *classical* truth values. In such a *bilateral* account of truth values, the first and second coordinates are often construed as representing distinct and independent *truth* and *falsity* values, respectively.

In the more epistemically-oriented context of Belnap’s artificial reasoner, the first coordinate of a semantical value represents whether a formula has been *reported as true* and the second coordinate represents whether a formula has been *reported as false*. For this reason, the values $\langle \mathbf{t}, \mathbf{f} \rangle$ and $\langle \mathbf{f}, \mathbf{t} \rangle$ correspond to \mathbf{t} and \mathbf{f} , respectively, in the earlier semantics. Similarly $\langle \mathbf{t}, \mathbf{t} \rangle$ corresponds to \mathbf{b} (*i.e.*, ‘both true and false’ is analogous to ‘it is true that the system has been told that the proposition is true and it is true that the system has been told that the proposition is false’) and $\langle \mathbf{f}, \mathbf{f} \rangle$ corresponds to \mathbf{n} (with a similar analogy). Many systems in this work admit a similarly bilateral semantics; we will decorate the names of such sets of truth values with the symbol \star to indicate that this is the case.

The bilateral semantics for E_{fde} is defined over the language \mathcal{L}_{zdf} and is described as follows:

Definition 5.2.1. *The bilateral semantics for E_{fde} is induced by the matrix $\mathfrak{M}_{E_{\text{fde}}}^*$, in which*

the set of truth values $\mathcal{V}_{E_{\text{FDE}}}^*$ is defined as $\{\mathbf{t}, \mathbf{f}\} \times \{\mathbf{t}, \mathbf{f}\}$ and the set of designated values $\mathcal{D}_{E_{\text{FDE}}}^*$ is $\{\langle \mathbf{t}, \mathbf{t} \rangle, \langle \mathbf{t}, \mathbf{f} \rangle\}$. To define the truth functions over the bilateral truth values, let f_{CL}^\wedge and f_{CL}^\vee denote the classical truth functions corresponding to conjunction and disjunction, respectively. Then the truth functions are defined as follows:

- $f_{E_{\text{FDE}}}^\neg(\langle \mathbf{v}_0, \mathbf{v}_1 \rangle) = \langle \mathbf{v}_1, \mathbf{v}_0 \rangle$
- $f_{E_{\text{FDE}}}^\wedge(\langle \mathbf{v}_0, \mathbf{v}_1 \rangle, \langle \mathbf{v}'_0, \mathbf{v}'_1 \rangle) = \langle f_{\text{CL}}^\wedge(\mathbf{v}_0, \mathbf{v}'_0), f_{\text{CL}}^\wedge(\mathbf{v}_1, \mathbf{v}'_1) \rangle$
- $f_{E_{\text{FDE}}}^\vee(\langle \mathbf{v}_0, \mathbf{v}_1 \rangle, \langle \mathbf{v}'_0, \mathbf{v}'_1 \rangle) = \langle f_{\text{CL}}^\vee(\mathbf{v}_0, \mathbf{v}'_0), f_{\text{CL}}^\vee(\mathbf{v}_1, \mathbf{v}'_1) \rangle$

A bilateral E_{FDE} valuation is a function v from \mathbf{At} to $\mathcal{V}_{E_{\text{FDE}}}^*$ extended so that

- $v(\neg A) = f_{E_{\text{FDE}}}^\neg(v(A))$
- $v(A \wedge B) = f_{E_{\text{FDE}}}^\wedge(v(A), v(B))$
- $v(A \vee B) = f_{E_{\text{FDE}}}^\vee(v(A), v(B))$

We write that $A \models_{E_{\text{FDE}}} B$ if for every bilateral E_{FDE} valuation v such that $v(A) \in \mathcal{D}_{E_{\text{FDE}}}^*$, also $v(B) \in \mathcal{D}_{E_{\text{FDE}}}^*$.

Note that insofar as the negation switches the two values, it can be thought of as a ‘toggle negation’ in the sense of Andreas Kapsner’s (119).

That inconsistent data does not ‘pollute’ the broader field of data should be clear; that a system has been provided data indicating that A is true and also data indicating that A is false is represented by a valuation v assigning A a semantical value of $\langle \mathbf{t}, \mathbf{t} \rangle$. In such occasions, $v(A \wedge \neg A) \in \mathcal{D}_{E_{\text{FDE}}}^*$. Yet this does not indicate that the system has been provided data suggesting the truth of atomic B , *i.e.*, this does not preclude v from assigning a non-designated semantical value such as $\langle \mathbf{f}, \mathbf{f} \rangle$ to an atom B . Hence, such a v witnesses that $A \wedge \neg A \not\models_{E_{\text{FDE}}} B$.

5.2.2 Single Address Faulty E_{fde}

While Belnap considers cases in which contradictory data are returned to an artificial reasoner, this is not the only type of potentially trivializing circumstance that may occur in such a system.

Consider how a Belnap computer evaluates a formula A : The system employs an algorithm to read the string of symbols corresponding to A and, upon reading each symbol, acts in some prescribed manner. For example, upon reading the symbol corresponding to a unary connective, the system will call a subprocedure (possibly itself) to calculate the semantical values of the requisite subformulae. Upon reading a *variable* B , however, the system will have to *recover* the value corresponding to B . To do this, it must obtain the address at which the semantical value of B is stored and access the memory at that address. Call the case in which both coordinates of the Belnap-type value are stored at a single address (*i.e.*, in which only one ‘piece’ of information is necessary to recover both coordinates) the ‘single address’ case.

Classical logic, of course, presupposes that every variable be assigned one and only one value so as to obey the principles of excluded middle and contradiction; this is the assumption that Belnap resists in (23). But a *further* presupposition—one not challenged by Belnap—is that the value is always *recoverable*. Irrespective of which of Belnap’s truth values is assigned to a variable, Belnap’s assumption is that a system is capable of querying the address at which this variable’s value is stored and retrieving its value. This does not hold in practice; a computer, for example, has finite memory and cannot allocate an address to each member of a denumerably infinite set of propositional variables. Furthermore, even supposing that an address *has* been assigned to hold the value, there could exist a physical flaw in the memory preventing the system from retrieving the value. In such cases, the algorithm to evaluate A will not be executed. The ‘partial functions’ tradition of interpreting such faults (such

as Kleene’s interpretation of the weak three-valued matrices of (122) or McCarthy’s truth tables of (132), appearing in Definitions 2.2.4 and 4.3.1, respectively), suggests that upon such faults, a system will fail to terminate. In practice, of course, such an occasion will lead to the system either terminating with an error or being held in an infinite loop as it attempts to locate a phantom resource. In either case, we may think of such errors as producing a third truth value.

Note that the situation in which, *e.g.*, an atom p is assigned Belnap’s ‘neither’ value is distinct from that in which its value is irrecoverable. In the former case, a system is perfectly capable of calculating the value of formulae C in which p appears; the system can retrieve the values of all atoms of C and calculate accordingly. If, however, the act of recovering the value of p triggers an error—suppose that such an action causes the system to crash—the system will be unable to perform this calculation. From an epistemological perspective, too, these situations are distinct. Under Belnap’s interpretation, when a ‘neither’ value is recovered for a variable p , the system possesses some information, namely, that it has received no data concerning p . When the system is unable to recover the value of p , it lacks even this meager information. As these scenarios differ in their behavior, it is natural to think of them as corresponding to distinct truth values.

In the single address E_{fde} case, we are able to model these circumstances by moving to a five-valued logic that serves as a bilateral version of the semantics for S_{fde}^* from Definition 4.1.5. We presuppose the Belnapian picture that the semantical value of a variable A represents data corresponding to both its truth as well as its falsity. Moreover, we assume that whatever data are being sent to the system concerning A may be stored at a single address so that recovery of the first and second coordinates of a truth value stand and fall together.

In addition to the bilateral semantical values of E_{fde} , then, we consider a fifth value $\langle \mathbf{u}, \mathbf{u} \rangle$ that represents a failure to retrieve a value.¹ Note that if variables p_0, \dots, p_{n-1} enumerate

¹That we are employing the value $\mathbf{u} \in \mathcal{V}_{\Sigma_0}$, *i.e.*, an infectious nonsense value, is not by accident.

$\text{At}(A)$, then an algorithm evaluating A demands the successful retrieval of the value of *each* atom p_i . Therefore, calculating the value of A will fail if for *any* p_i there is an error in its retrieval.

The bilateral account of the Daniels-Priest system S_{fde}^* is as follows:

Definition 5.2.2. *The bilateral semantics for S_{fde}^* is induced by the matrix $\mathfrak{M}_{S_{\text{fde}}^*} = \langle \mathcal{V}_{S_{\text{fde}}^*}, \mathcal{D}_{S_{\text{fde}}^*}, f_{S_{\text{fde}}^*}^{\dot{\cdot}}, f_{S_{\text{fde}}^*}^{\wedge}, f_{S_{\text{fde}}^*}^{\check{\cdot}} \rangle$ where the set of truth values is $\mathcal{V}_{E_{\text{fde}}^*} \cup \{\langle \mathbf{u}, \mathbf{u} \rangle\}$ and the set of designated values $\mathcal{D}_{S_{\text{fde}}^*} = \mathcal{D}_{E_{\text{fde}}^*}$.*

The truth functions $f_{S_{\text{fde}}^}^{\dot{\cdot}}, f_{S_{\text{fde}}^*}^{\wedge}$, and $f_{S_{\text{fde}}^*}^{\check{\cdot}}$ can be defined by referencing their analogous functions in the bilateral semantics for E_{fde} . Letting $\circ \in \{\dot{\cdot}, \wedge, \check{\cdot}\}$, the definitions are:*

$$\begin{aligned} \bullet f_{S_{\text{fde}}^*}^{\dot{\cdot}}(\langle \mathbf{v}_0, \mathbf{v}_1 \rangle) &= \begin{cases} \langle \mathbf{u}, \mathbf{u} \rangle & \text{if } \mathbf{v}_0 = \mathbf{v}_1 = \mathbf{u} \\ f_{E_{\text{fde}}}^{\dot{\cdot}}(\langle \mathbf{v}_0, \mathbf{v}_1 \rangle) & \text{otherwise} \end{cases} \\ \bullet f_{S_{\text{fde}}^*}^{\circ}(\langle \mathbf{v}_0, \mathbf{v}_1 \rangle, \langle \mathbf{v}'_0, \mathbf{v}'_1 \rangle) &= \begin{cases} \langle \mathbf{u}, \mathbf{u} \rangle & \text{if } \mathbf{v}_0 = \mathbf{v}_1 = \mathbf{u} \text{ or } \mathbf{v}'_0 = \mathbf{v}'_1 = \mathbf{u} \\ f_{E_{\text{fde}}}^{\circ}(\langle \mathbf{v}_0, \mathbf{v}_1 \rangle, \langle \mathbf{v}'_0, \mathbf{v}'_1 \rangle) & \text{otherwise} \end{cases} \end{aligned}$$

While E_{fde} permits the inference to $A \dot{\vee} B$ from A , *i.e.*, $A \vDash_{E_{\text{fde}}} A \dot{\vee} B$, the principle of Addition fails for S_{fde}^* . Consider a bilateral S_{fde}^* valuation v such that for atoms p and q , $v(p) = \langle \mathbf{t}, \mathbf{f} \rangle$ and $v(q) = \langle \mathbf{u}, \mathbf{u} \rangle$. Then $v(p) \in \mathcal{D}_{S_{\text{fde}}^*}$ although $v(p \dot{\vee} q) = \langle \mathbf{u}, \mathbf{u} \rangle$, whence $v(p \dot{\vee} q) \notin \mathcal{D}_{S_{\text{fde}}^*}$. Such a valuation witnesses that this inference is not valid in S_{fde}^* .

5.2.3 Two Address Faulty E_{fde}

We will now further complicate the Belnapian picture by revisiting the issue of faults when retrieving a semantical value. We had considered the case in which *both* types of report with respect to a variable p were stored at a single address. This type of reading licenses the inference $A \vDash_{S_{\text{fde}}^*} A \dot{\vee} \dot{\wedge} A$; that A takes a designated value implies that the location at

which the value of the truth of A is stored is accessible.² If this is the same address as that at which the value of $\dot{\neg}A$, *i.e.*, the value corresponding to whether A is *false*, is stored, then the system is able to pull up the value of $\dot{\neg}A$ when evaluating $A \dot{\vee} \dot{\neg}A$. In such cases, of course, it will find $A \dot{\vee} \dot{\neg}A$ to take a designated value.

That said, an equally—if not more—reasonable implementation of the Belnapian picture would employ a *pair* of addresses for each atom p : One to store a flag that p has been affirmed and another to store a flag that p has been denied, *i.e.*, an address for each coordinate of the semantical value of p . If, *e.g.*, only a single bit is allocated at a time, then each coordinate will require a distinct address.

Note that the bilateral semantics for S_{fde}^* was defined in terms of the classical truth functions that govern reports of truth and falsity so that in a sense, S_{fde}^* can be interpreted as employing two parallel systems of positive classical logic to calculate truth and falsity independently of one another. The system that will arise from the ‘two address’ treatment of Belnap’s picture will bear the same relation to Bochvar/Kleene weak three-valued logic defined in Definition 2.2.4.

We have seen in the foregoing that Σ_0 is closely related to a number of containment logics. Σ_0 bears an equally deep relationship with the semantics we will now outline. Call the semantical system to be introduced NC , defined with respect to the same language as that of AC .

Definition 5.2.3. NC is defined by the set of truth values $\mathcal{V}_{\text{NC}} = \mathcal{V}_{\Sigma_0} \times \mathcal{V}_{\Sigma_0}$ and $\mathcal{D}_{\text{NC}} = \{\langle \mathbf{t}, \mathbf{v} \rangle \mid \mathbf{v} \in \mathcal{V}_{\Sigma_0}\}$.

The truth functions $f_{\text{NC}}^{\dot{\neg}}$, $f_{\text{NC}}^{\dot{\wedge}}$, and $f_{\text{NC}}^{\dot{\vee}}$ corresponding to negation, conjunction, and disjunction, respectively, are defined so that for all $\langle \mathbf{v}_0, \mathbf{v}_1 \rangle, \langle \mathbf{v}'_0, \mathbf{v}'_1 \rangle \in \mathcal{V}_{\text{NC}}$,

- $f_{\text{NC}}^{\dot{\neg}}(\langle \mathbf{v}_0, \mathbf{v}_1 \rangle) = \langle \mathbf{v}_1, \mathbf{v}_0 \rangle$

²We will see that this inference in a sense *characterizes* the single address account, as the proof theory for S_{fde}^* is equivalent to the addition of this inference to the logic determined by the two address case.

$$\bullet f_{\text{NC}}^{\dot{\wedge}}(\langle \mathbf{v}_0, \mathbf{v}_1 \rangle, \langle \mathbf{v}'_0, \mathbf{v}'_1 \rangle) = \langle f_{\Sigma_0}^{\dot{\wedge}}(\mathbf{v}_0, \mathbf{v}'_0), f_{\Sigma_0}^{\dot{\vee}}(\mathbf{v}_1, \mathbf{v}'_1) \rangle$$

$$\bullet f_{\text{NC}}^{\dot{\vee}}(\langle \mathbf{v}_0, \mathbf{v}_1 \rangle, \langle \mathbf{v}'_0, \mathbf{v}'_1 \rangle) = \langle f_{\Sigma_0}^{\dot{\vee}}(\mathbf{v}_0, \mathbf{v}'_0), f_{\Sigma_0}^{\dot{\wedge}}(\mathbf{v}_1, \mathbf{v}'_1) \rangle$$

An NC valuation is a function from \mathbf{At} to $\mathcal{V}_{\Sigma_0} \times \mathcal{V}_{\Sigma_0}$ extended so that

$$\bullet v(\dot{\neg} A) = f_{\text{NC}}^{\dot{\neg}}(v(A))$$

$$\bullet v(A \dot{\wedge} B) = f_{\text{NC}}^{\dot{\wedge}}(v(A), v(B))$$

$$\bullet v(A \dot{\vee} B) = f_{\text{NC}}^{\dot{\vee}}(v(A), v(B))$$

Before connecting the system NC to AC, we pause to demonstrate some useful features of the system NC.

Observation 5.2.1. NC is a subsystem of \mathbf{E}_{fde}

Proof. The set $\{\langle \mathbf{t}, \mathbf{f} \rangle, \langle \mathbf{t}, \mathbf{t} \rangle, \langle \mathbf{f}, \mathbf{f} \rangle, \langle \mathbf{f}, \mathbf{t} \rangle\}$ is just $\mathcal{V}_{\mathbf{E}_{\text{fde}}}$. Furthermore, it can be calculated that the system \mathbf{E}_{fde} , *i.e.*, its values, designated values, and truth functions, can be recovered by restricting NC to $\mathcal{V}_{\mathbf{E}_{\text{fde}}}^*$. \square

Let \mathbf{Lit} denote the set of literals, *i.e.*, $\mathbf{Lit} = \mathbf{At} \cup \{\dot{\neg} A \mid A \in \mathbf{At}\}$. Then we provide the following definition:

Definition 5.2.4. The literal normal form of a formula A (denoted A^{NF}) is recursively defined as follows:

$$\bullet A^{NF} = A \text{ for } A \in \mathbf{Lit}$$

$$\bullet (A \dot{\wedge} B)^{NF} = A^{NF} \dot{\wedge} B^{NF}$$

$$\bullet (A \dot{\vee} B)^{NF} = A^{NF} \dot{\vee} B^{NF}$$

$$\bullet (\dot{\neg} \dot{\neg} A)^{NF} = A^{NF}$$

- $(\dot{\neg}(A \dot{\wedge} B))^{NF} = (\dot{\neg}A)^{NF} \dot{\vee} (\dot{\neg}B)^{NF}$
- $(\dot{\neg}(A \dot{\vee} B))^{NF} = (\dot{\neg}A)^{NF} \dot{\wedge} (\dot{\neg}B)^{NF}$

Lemma 5.2.1. *For any NC valuation v , $v(A) = v(A^{NF})$*

Proof. By induction on complexity of formulae. Clearly, $v(A) = v(A^{NF})$ for $A \in \mathbf{Lit}$. As induction hypothesis, assume that $v(A) = v(A^{NF})$ and $v(B) = v(B^{NF})$.

For $v(A \dot{\wedge} B)$ and $v(A \dot{\vee} B)$, note that

$$v((A \dot{\wedge} B)^{NF}) = v(A^{NF} \dot{\wedge} B^{NF}) = f_{\text{NC}}^{\dot{\wedge}}(v(A^{NF}), v(B^{NF})) = f_{\text{NC}}^{\dot{\wedge}}(v(A), v(B)).$$

But this is just $v(A \dot{\wedge} B)$; the case of disjunction proceeds identically, other things being equal.

There are three cases to consider for negated formulae. For double negation, $v(\dot{\neg}\dot{\neg}A) = v(A)$ and A is $(\dot{\neg}\dot{\neg}A)^{NF}$. For negated conjunctions $\dot{\neg}(A \dot{\wedge} B)$, we observe that by definitions and the induction hypothesis, we have the following: $v((\dot{\neg}(A \dot{\wedge} B))^{NF}) = v((\dot{\neg}A)^{NF} \dot{\vee} (\dot{\neg}B)^{NF}) = f_{\text{NC}}^{\dot{\vee}}(v((\dot{\neg}A)^{NF}), v((\dot{\neg}B)^{NF})) = f_{\text{NC}}^{\dot{\vee}}(v(\dot{\neg}A), v(\dot{\neg}B))$. By definition, this is equal to

$f_{\text{NC}}^{\dot{\vee}}(f_{\text{NC}}^{\dot{\neg}}(v(A)), f_{\text{NC}}^{\dot{\neg}}(v(B)))$. But it can be easily confirmed that this is equivalent to $f_{\text{NC}}^{\dot{\neg}}(f_{\text{NC}}^{\dot{\wedge}}(v(A), v(B)))$, *i.e.*, $v(\dot{\neg}(A \dot{\wedge} B))$. Finally, the case of negated disjunctions follows analogously. \square

Definition 5.2.5. *The sets $\mathbf{At}^+(A)$ —the positive atoms of A and $\mathbf{At}^-(A)$ —the negative atoms of A —are recursively defined:*

- $\mathbf{At}^+(A) = \{A\}$ for $A \in \mathbf{At}$
- $\mathbf{At}^-(A) = \emptyset$ for $A \in \mathbf{At}$
- $\mathbf{At}^+(\dot{\neg}A) = \mathbf{At}^-(A)$

- $\mathbf{At}^-(\dot{\neg} A) = \mathbf{At}^+(A)$
- $\mathbf{At}^+(A \circ B) = \mathbf{At}^+(A) \cup \mathbf{At}^+(B)$ for $\circ \in \{\dot{\wedge}, \dot{\vee}\}$
- $\mathbf{At}^-(A \circ B) = \mathbf{At}^-(A) \cup \mathbf{At}^-(B)$ for $\circ \in \{\dot{\wedge}, \dot{\vee}\}$

A simple induction can be employed to prove that NC inherits a form of the ‘infectiousness’ of the truth value \mathbf{u} from Σ_0 . Let pr_0 and pr_1 be the projection functions mapping ordered pairs to their first and second coordinates, respectively.

Lemma 5.2.2. *For an atomic formula A , an arbitrary formula B , and an NC valuation v ,*

- *if $A \in \mathbf{At}^+(B)$ and $\text{pr}_0(v(A)) = \mathbf{u}$ then $v(B) \notin \mathcal{D}_{\text{NC}}$*
- *if $A \in \mathbf{At}^-(B)$ and $\text{pr}_1(v(A)) = \mathbf{u}$ then $v(B) \notin \mathcal{D}_{\text{NC}}$*

Proof. By induction on complexity of formulae. □

Having noted these features of the system NC, we will now prove the equivalence of NC with Richard Angell’s system of *analytic containment* AC.

5.3 Angell’s Analytic Containment AC

In the following, we will prove equivalence between the nine-valued semantics and the logic of analytic containment AC, which has been discussed and defined in Section 3.1.3.

We will construe the connective \rightarrow from the axiomatization in Section 3.1.3 as a consequence relation so that $A \vdash_{\text{AC}} B$ will be interpreted as equivalent to the theoremhood of $A \rightarrow B$ in AC.

5.3.1 Correia Semantics for Analytic Containment

Angell himself never published semantics for AC.³ The first semantics for the system was discovered by Correia in (49), which we rehearse immediately below:

Correia's models are essentially collections of elements that we will call *Correia pairs*. Let ' \Subset ' denote the finite subset relation (*i.e.*, let $X \Subset Y$ mean that X is a finite subset of Y). Then:

Definition 5.3.1. *A Correia pair is an ordered pair $\langle \Gamma, \Delta \rangle$ where $\Gamma \Subset \mathbf{At}$, $\Delta \Subset \mathbf{At}$, and $\Gamma \cup \Delta \neq \emptyset$.*

Note that the definition demands that Γ and Δ be *finite*. Although this definition is not assumed by Correia in (50), we will offer justification for this assumption shortly.

From this constituent material, we define Correia models.

Definition 5.3.2. *A Correia model \mathbf{v} is a nonempty collection of Correia pairs.*

The first step towards generating interesting relations in a Correia model is the recursive definition of a relation $\vDash_{\mathbf{v}}$:

Definition 5.3.3. *The relation $\vDash_{\mathbf{v}} \subseteq \wp(\mathcal{L}_{\text{zdf}}) \times \wp(\mathcal{L}_{\text{zdf}})$ is defined recursively by the following clauses:*

- $\Gamma \vDash_{\mathbf{v}} \Delta$ iff $\langle \Gamma, \Delta \rangle \in \mathbf{v}$ for $\Gamma, \Delta \Subset \mathbf{At}$
- $\Gamma \vDash_{\mathbf{v}} \Delta, \dot{\neg} A$ iff $\Gamma, A \vDash_{\mathbf{v}} \Delta$
- $\Gamma, \dot{\neg} A \vDash_{\mathbf{v}} \Delta$ iff $\Gamma \vDash_{\mathbf{v}} \Delta, A$
- $\Gamma \vDash_{\mathbf{v}} \Delta, A \dot{\vee} B$ iff $\Gamma \vDash_{\mathbf{v}} \Delta, A, B$

³Angell asserts the existence of a semantics for 'analytic equivalence' by employing 'analytic truth tables' in the abstract (10). Possibly due to the severe constraints on space, however, Angell's definition of an analytic truth table is not entirely clear.

- $\Gamma, A \dot{\vee} B \vDash_{\mathbf{v}} \Delta$ iff both $\Gamma, A \vDash_{\mathbf{v}} \Delta$ and $\Gamma, B \vDash_{\mathbf{v}} \Delta$
- $\Gamma \vDash_{\mathbf{v}} \Delta, A \dot{\wedge} B$ iff both $\Gamma \vDash_{\mathbf{v}} \Delta, A$ and $\Gamma \vDash_{\mathbf{v}} \Delta, B$
- $\Gamma, A \dot{\wedge} B \vDash_{\mathbf{v}} \Delta$ iff $\Gamma, A, B \vDash_{\mathbf{v}} \Delta$

An instance of the relation $\Gamma \Vdash_{\mathbf{v}} \Delta$ will be referred to as a ‘pseudosequent’ in the sequel. Intuitively, a pseudosequent $\Gamma \vDash_{\mathbf{v}} \Delta$ is to be read as the assertion that with respect to the model \mathbf{v} , the disjunction whose disjuncts comprise each of the members of Δ and the negated members of Γ is true. It follows that a formula A is considered *true* in a model \mathbf{v} if $\emptyset \vDash_{\mathbf{v}} A$.⁴

A formula A is true in a model \mathbf{v} when the pseudosequent $\emptyset \Vdash_{\mathbf{v}} A$ can be derived from a pseudosequent $\Gamma \Vdash_{\mathbf{v}} \Delta$ in which $\Gamma, \Delta \subset \mathbf{At}$ by a finite number of applications of the above rules.

Correia notes that the logic corresponding to all models without restriction is much weaker than **AC**, *e.g.*, there exist countermodels to the **AC** theorem $(p \dot{\wedge} (q \dot{\vee} r)) \rightarrow (p \dot{\vee} q)$. In order to properly characterize **AC**, we must restrict our attention to only Correia models satisfying a particular property. In (49), Correia characterizes **AC** in terms of models satisfying the following condition:

Definition 5.3.4 (Condition AC). *For all sets of atoms $\Gamma, \Gamma', \Gamma'', \Delta, \Delta',$ and Δ'' if $\langle \Gamma, \Delta \rangle \in \mathbf{v}$ and $\langle \Gamma' \cup \Gamma'', \Delta' \cup \Delta'' \rangle \in \mathbf{v}$ then $\langle \Gamma \cup \Gamma', \Delta \cup \Delta' \rangle \in \mathbf{v}$*

We will, however be interested also in an alternative (although equivalent) property of *vocabulary closure*. As an intermediate step towards the introduction of this property, we define a binary relation \preceq between pairs of sets of atoms.

Definition 5.3.5. *The relation \preceq between two pairs of sets of formulae $\langle \Gamma, \Delta \rangle$ and $\langle \Gamma', \Delta' \rangle$ is defined so that*

⁴Note that as the conditions for $\Vdash_{\mathbf{v}}$ provide no means of *eliminating* instances of formulae from a pseudosequent, whenever a pseudosequent $\emptyset \Vdash_{\mathbf{v}} A$ is derivable, it is derivable after a finite number of manipulations of a finite initial pseudosequent $\Gamma \Vdash_{\mathbf{v}} \Delta$. Hence, it is always sufficient to consider *finite* Correia models, justifying our assumption of the finitude of Correia models \mathbf{v} .

$$\langle \Gamma, \Delta \rangle \preceq \langle \Gamma', \Delta' \rangle \text{ iff } \begin{cases} \Gamma \subseteq \Gamma' & , \text{ and} \\ \Delta \subseteq \Delta' \end{cases}$$

Note that the relation \preceq is defined for arbitrary pairs of sets of formulae without qualification (rather than Correia pairs). Hence, the relation $\langle \Gamma, \Delta \rangle \preceq \langle \Gamma', \Delta' \rangle$ is well-defined even when Γ' and Δ' are infinite.

Consider also the following definition:

Definition 5.3.6. *The negative and positive vocabularies of a Correia model \mathbf{v} — $\Gamma_{\mathbf{v}}^*$ and $\Delta_{\mathbf{v}}^*$, respectively—are defined so that:*

- $\Gamma_{\mathbf{v}}^* = \{p \in \mathbf{At} \mid \exists \langle \Gamma, \Delta \rangle \in \mathbf{v} \text{ such that } p \in \Gamma\}$
- $\Delta_{\mathbf{v}}^* = \{p \in \mathbf{At} \mid \exists \langle \Gamma, \Delta \rangle \in \mathbf{v} \text{ such that } p \in \Delta\}$

Now we are prepared to define the alternative property corresponding to the class of Correia models in terms of which AC validity may be defined.

Definition 5.3.7. *The vocabulary closure of a Correia model \mathbf{v} —symbolized $\llbracket \mathbf{v} \rrbracket$ —is the smallest Correia model \mathbf{v}' extending \mathbf{v} such that:*

- *for all Correia pairs $\langle \Gamma, \Delta \rangle \preceq \langle \Gamma_{\mathbf{v}}^*, \Delta_{\mathbf{v}}^* \rangle$, if there exists a $\langle \Gamma', \Delta' \rangle \in \mathbf{v}$ such that $\langle \Gamma', \Delta' \rangle \preceq \langle \Gamma, \Delta \rangle$, then $\langle \Gamma, \Delta \rangle \in \mathbf{v}'$*

I.e., the set $\{\langle \Gamma, \Delta \rangle \mid \exists \langle \Gamma', \Delta' \rangle \in \mathbf{v} \text{ s.t. } \langle \Gamma', \Delta' \rangle \preceq \langle \Gamma, \Delta \rangle \preceq \langle \Gamma_{\mathbf{v}}^*, \Delta_{\mathbf{v}}^* \rangle\}$.

We say a Correia model \mathbf{v} is vocabulary closed if $\mathbf{v} = \llbracket \mathbf{v} \rrbracket$.

The equivalence between vocabulary closed models and those satisfying Condition AC is clear. Hence, Correia's results in (49) entail that AC corresponds to the preservation of truth in vocabulary closed models.

This provides us with the necessary apparatus to define AC validity:

Definition 5.3.8. $A \vDash_{\text{AC}} B$ iff for every vocabulary closed Correia model \mathbf{v} , if $\emptyset \Vdash_{\mathbf{v}} A$ then $\emptyset \Vdash_{\mathbf{v}} B$

5.3.2 Equivalence of NC and AC

We wish to show that the truth functional semantics captures Angell's system AC. We proceed by showing that all axioms of Angell's system correspond to valid inferences in NC and that the rules of Angell's system preserve validity when applied to an NC inference. Recall that the functions pr_0 and pr_1 are the operators projecting a pair onto the first and second coordinate, respectively and that the notation ' $f[X]$ ' represents the image of X under f .

Then, the first move towards proving equivalence is proving that anything valid inference in AC is a valid inference modulo the nine-valued semantics. We show this by evaluating the rules and axioms of AC and demonstrating that they correspond to valid inferences in NC.

Lemma 5.3.1. *The axioms AC1–AC6b are valid in NC*

Proof. The validity of each of the axioms may be directly inferred by appeal to the truth functions. □

To establish the validity of other axioms of AC, we prove some intermediate lemmas:

Lemma 5.3.2. *If $A \vDash_{\text{NC}} B$ and $B \vDash_{\text{NC}} A$ then $\mathbf{At}^+(A) = \mathbf{At}^+(B)$ and $\mathbf{At}^-(A) = \mathbf{At}^-(B)$*

Proof. Without loss of generality, suppose that $A \vDash_{\text{NC}} B$ and there is an atomic $p \in \mathbf{At}^+(B)$ although $p \notin \mathbf{At}^+(A)$. Then consider a valuation v such that $v(A) \in \mathcal{D}_{\text{NC}}$ and $v(B) \in \mathcal{D}_{\text{NC}}$. Next, construct a valuation v' differing from v only in that it assigns the first coordinate of p the value \mathbf{u} . Because v' agrees with v on all atoms appearing in A , the value of A remains unchanged, i.e., $v'(A) \in \mathcal{D}_{\text{NC}}$. However, by Lemma 5.2.2, that $\text{pr}_0(v'(p)) = \mathbf{u}$ entails that $v'(B) \notin \mathcal{D}_{\text{NC}}$. Hence, $A \not\vDash_{\text{NC}} B$. □

Lemma 5.3.3. *With respect to an NC valuation v , if $\mathbf{u} \notin \text{pr}_0[v[\mathbf{At}^+(A)]]$ and $\mathbf{u} \notin \text{pr}_1[v[\mathbf{At}^-(A)]]$ then for any NC valuation v' agreeing with v with respect to these values, $v(A) \in \mathcal{D}_{\text{NC}}$ iff $v'(A) \in \mathcal{D}_{\text{NC}}$*

Proof. Suppose that $\mathbf{u} \notin \text{pr}_0[v[\mathbf{At}^+(A)]]$ and $\mathbf{u} \notin \text{pr}_1[v[\mathbf{At}^-(A)]]$. Then we may prove the lemma by induction on complexity of A^{NF} (i.e., the literal normal form of A). In the case of literals p or $\dot{\neg}p$, $p \in \mathbf{At}^+(A)$ or $p \in \mathbf{At}^-(A)$. The selection of v' ensures that v and v' agree on these sets, whence $v(p) = v'(p)$ or $v(\dot{\neg}p) = v'(\dot{\neg}p)$ as the case requires.

As induction hypothesis, suppose that this property holds for all subformulae of A^{NF} . If $A^{NF} = B \dot{\wedge} C$, then $v(B \dot{\wedge} C) \in \mathcal{D}_{\text{NC}}$ iff $v(B) \in \mathcal{D}_{\text{NC}}$ and $v(C) \in \mathcal{D}_{\text{NC}}$. This by hypothesis holds iff $v'(B) \in \mathcal{D}_{\text{NC}}$ and $v'(C) \in \mathcal{D}_{\text{NC}}$, i.e., $v'(A \dot{\wedge} B) \in \mathcal{D}_{\text{NC}}$. Disjunction follows from an identical proof.

Hence, as $v(A) \in \mathcal{D}_{\text{NC}}$ iff $v(A^{NF}) \in \mathcal{D}_{\text{NC}}$, we conclude that $v(A) \in \mathcal{D}_{\text{NC}}$ iff $v'(A) \in \mathcal{D}_{\text{NC}}$. □

Lemma 5.3.4. *The inference rule AC7 is validity preserving*

Proof. By Lemma 5.3.2, whenever both $A \vDash_{\text{NC}} B$ and $B \vDash_{\text{NC}} A$ we may infer that $\mathbf{At}^+(A) = \mathbf{At}^+(B)$ and $\mathbf{At}^-(A) = \mathbf{At}^-(B)$. But $\mathbf{At}^+(A) = \mathbf{At}^-(\dot{\neg}A)$ and *mutatis mutandis* for B , whence $\dot{\neg}A$ and $\dot{\neg}B$ share positive and negative atoms.

Now suppose for contradiction that $\dot{\neg}A \not\vDash_{\text{NC}} \dot{\neg}B$. Then there is an NC valuation v such that $v(\dot{\neg}A) \in \mathcal{D}_{\text{NC}}$ and $v(\dot{\neg}B) \notin \mathcal{D}_{\text{NC}}$. By Lemma 5.2.2, that $v(\dot{\neg}A) \in \mathcal{D}_{\text{NC}}$ entails that $\mathbf{u} \notin \text{pr}_0[v[\mathbf{At}^+(\dot{\neg}A)]]$ and $\mathbf{u} \notin \text{pr}_1[v[\mathbf{At}^-(\dot{\neg}A)]]$. That $\mathbf{At}^+(\dot{\neg}A) = \mathbf{At}^+(\dot{\neg}B)$ and $\mathbf{At}^-(\dot{\neg}A) = \mathbf{At}^-(\dot{\neg}B)$ entails that this holds for $\dot{\neg}B$ as well.

Construct an NC valuation v'' by the following scheme for all atoms p :

$$v''(p) = \begin{cases} \langle \mathbf{t}, \mathbf{t} \rangle & \text{if } v(p) = \langle \mathbf{t}, \mathbf{u} \rangle \text{ or } v(p) = \langle \mathbf{u}, \mathbf{t} \rangle \text{ or } v(p) = \langle \mathbf{u}, \mathbf{u} \rangle \\ \langle \mathbf{f}, \mathbf{t} \rangle & \text{if } v(p) = \langle \mathbf{f}, \mathbf{u} \rangle \\ \langle \mathbf{t}, \mathbf{f} \rangle & \text{if } v(p) = \langle \mathbf{u}, \mathbf{f} \rangle \\ v(p) & \text{otherwise} \end{cases}$$

Then v and v'' agree on the first coordinates of the values assigned to $\mathbf{At}^+(\dot{A})$ and the second coordinates of values assigned to $\mathbf{At}^-(\dot{A})$. Hence, by Lemma 5.3.3, $v''(\dot{A}) \in \mathcal{D}_{\text{NC}}$ iff $v(\dot{A}) \in \mathcal{D}_{\text{NC}}$ and $v''(\dot{B}) \in \mathcal{D}_{\text{NC}}$ iff $v(\dot{B}) \in \mathcal{D}_{\text{NC}}$. But v'' is a bilateral \mathbf{E}_{fde} valuation because the values assigned to all formulae are in $\mathcal{V}_{\text{E}_{\text{fde}}}^*$, whence v'' witnesses that $\dot{A} \not\models_{\text{E}_{\text{fde}}} \dot{B}$.

However, we also note that as a subsystem of \mathbf{E}_{fde} , that $B \models_{\text{NC}} A$ entails that $B \models_{\text{E}_{\text{fde}}} A$. In turn, $B \models_{\text{E}_{\text{fde}}} A$ entails that $\dot{A} \models_{\text{E}_{\text{fde}}} \dot{B}$ (cf. the axiomatization in (24)), whence we infer that $\dot{A} \models_{\text{E}_{\text{fde}}} \dot{B}$. This contradicts our earlier conclusion that $\dot{A} \not\models_{\text{E}_{\text{fde}}} \dot{B}$. \square

Lemma 5.3.5. *The inference rules **AC8**–**AC9** are validity preserving*

Proof. That **AC8** and **AC9** preserve designated validity is trivial, **AC8** by appeal to the truth tables and **AC9** by the definition of validity. \square

We are now equipped to prove correctness of **AC** with respect to **NC**.

Theorem 5.3.1. *If $A \models_{\text{AC}} B$ then $A \models_{\text{NC}} B$*

Proof. Suppose that $A \models_{\text{AC}} B$. Then, by completeness of the Correia semantics with respect to the axioms, there exists a proof of $A \rightarrow B$ from the axioms of **AC**. But all axioms are valid inferences of **NC** and the inferences are validity preserving. Hence, $A \models_{\text{NC}} B$. \square

Now, to prove equivalence of **AC** and **NC**, we must prove the converse of Theorem 5.3.1, *i.e.*, we must show that **NC** is a subsystem of **AC**. To do so, we will need some further notation and a lemma concerning Correia models.

Definition 5.3.9. The operation Υ is defined so that for two Correia pairs $\langle \Gamma, \Delta \rangle$ and $\langle \Gamma', \Delta' \rangle$, $\langle \Gamma, \Delta \rangle \Upsilon \langle \Gamma', \Delta' \rangle = \langle \Gamma \cup \Gamma', \Delta \cup \Delta' \rangle$

Note that the relation \preceq defined in Definition 5.3.5 admits a characterization in terms of Υ , i.e., $\langle \Gamma, \Delta \rangle \preceq \langle \Gamma', \Delta' \rangle$ holds if and only if $\langle \Gamma, \Delta \rangle \Upsilon \langle \Gamma', \Delta' \rangle = \langle \Gamma', \Delta' \rangle$.

We also define two further properties in terms of Υ :

Definition 5.3.10. With respect to a Correia model \mathbf{v} , a pair $\langle \Gamma, \Delta \rangle \in \mathbf{v}$ is a Υ -minimal element of \mathbf{v} if for all $\langle \Gamma', \Delta' \rangle \in \mathbf{v}$, if $\langle \Gamma', \Delta' \rangle \preceq \langle \Gamma, \Delta \rangle$ then $\langle \Gamma', \Delta' \rangle = \langle \Gamma, \Delta \rangle$.

Definition 5.3.11. The set of generators of a Correia model \mathbf{v} —symbolized $\mathfrak{G}(\mathbf{v})$ —is the set of Υ -minimal elements of \mathbf{v} , i.e., the set:

$$\{\langle \Gamma, \Delta \rangle \in \mathbf{v} \mid \forall \langle \Gamma', \Delta' \rangle \in \mathbf{v} \text{ if } \langle \Gamma', \Delta' \rangle \preceq \langle \Gamma, \Delta \rangle \text{ then } \langle \Gamma', \Delta' \rangle = \langle \Gamma, \Delta \rangle\}.$$

With these definitions in hand, we can make the following observation:

Lemma 5.3.6. For any Correia model \mathbf{v} and every Correia pair $\langle \Gamma, \Delta \rangle \in \mathbf{v}$, there exists a Correia pair $\langle \Gamma', \Delta' \rangle \in \mathfrak{G}(\mathbf{v})$ such that $\langle \Gamma', \Delta' \rangle \preceq \langle \Gamma, \Delta \rangle$

Proof. Consider an arbitrary $\langle \Gamma, \Delta \rangle \in \mathbf{v}$; we prove the existence of an appropriate pair $\langle \Gamma', \Delta' \rangle \in \mathfrak{G}(\mathbf{v})$ by arguing by cases. Either there exists a distinct $\langle \Gamma', \Delta' \rangle \in \mathbf{v}$ such that $\langle \Gamma', \Delta' \rangle \preceq \langle \Gamma, \Delta \rangle$ or not.

If there is such an element of \mathbf{v} , then because Γ, Δ are finite, the chain

$$\dots \preceq \langle \Gamma'', \Delta'' \rangle \preceq \dots \preceq \langle \Gamma, \Delta \rangle$$

must terminate at some initial pair $\langle \Gamma''', \Delta''' \rangle \in \mathbf{v}$. But if $\langle \Gamma''', \Delta''' \rangle$ is the terminal element of the chain, then $\langle \Gamma''', \Delta''' \rangle \in \mathfrak{G}(\mathbf{v})$ and may thus serve as the required Correia pair in \mathbf{v} .

If there is no such element of \mathbf{v} , then $\langle \Gamma, \Delta \rangle \in \mathfrak{G}(\mathbf{v})$ and by reflexivity of \preceq , $\langle \Gamma, \Delta \rangle$ is itself the required Correia pair.

□

When $\Gamma \subseteq \mathcal{L}_{\text{zdf}}$, then let $\Gamma^\dot{\neg}$ represent the set $\{\dot{\neg}A \mid A \in \Gamma\}$. Now, in (49), Correia maintains an explicit ‘analogy’ with sequents (or consecutions) in the style of Gentzen, an analogy made salient by the likeness that a Correia pair $\langle \Gamma, \Delta \rangle$ bears to a sequent $\Gamma \Rightarrow \Delta$. This analogy permits us to apply a proof-theoretic observation due to William Tait (as reported by Wolfram Pohlers in (152)) that whenever the antecedent and succedent of a sequent contain only atomic formulae, one can encode all of the information in that sequent by means of a *single* set of formulae, *i.e.*, whenever $\Gamma \cup \Delta \subseteq \mathbf{At}$, one can recover all of the information in a sequent $\Gamma \Rightarrow \Delta$ from the set $\Gamma^\dot{\neg} \cup \Delta$.

Definition 5.3.12. *For a Correia pair $\langle \Gamma, \Delta \rangle$, the literal projection of $\langle \Gamma, \Delta \rangle$ —symbolized by $\langle \Gamma, \Delta \rangle^\tau$ —is the set $\Gamma^\dot{\neg} \cup \Delta$. When X is a set of Correia pairs, X^τ will be defined as the set of literal projections of its elements.*

For example, where $\mathfrak{G}(\mathbf{v})$ is the set of generators of a Correia model \mathbf{v} , $\mathfrak{G}(\mathbf{v})^\tau$ is the collection of literal projections of elements of $\mathfrak{G}(\mathbf{v})$.

Definition 5.3.13. *Where $\mathfrak{G}(\mathbf{v})$ is the set of generators of a Correia model \mathbf{v} , $\prod(\mathfrak{G}(\mathbf{v})^\tau)$ is the set of all choice functions on $\mathfrak{G}(\mathbf{v})^\tau$, that is:*

$$\prod(\mathfrak{G}(\mathbf{v})^\tau) = \{C : \mathfrak{G}(\mathbf{v})^\tau \rightarrow \cup \mathfrak{G}(\mathbf{v})^\tau \mid C(\langle \Gamma, \Delta \rangle^\tau) \in \langle \Gamma, \Delta \rangle^\tau\}$$

Recall that pr_0 and pr_1 are the projection operators projecting pairs onto their first and second coordinates, respectively. Then for each choice function $C \in \prod(\mathfrak{G}(\mathbf{v})^\tau)$, we can associate a many-valued NC valuation v_C :

Definition 5.3.14. *Suppose that \mathbf{v} is a vocabulary closed Correia model and consider a choice function $C \in \prod(\mathfrak{G}(\mathbf{v})^\tau)$. Then we define the NC valuation v_C so that:*

$$\text{pr}_0(v_C(p)) = \begin{cases} \mathbf{t} & \text{if } \exists \langle \Gamma, \Delta \rangle^\tau \in \mathfrak{G}(\mathbf{v})^\tau \text{ such that } C(\langle \Gamma, \Delta \rangle^\tau) = p \\ \mathbf{f} & \text{if } \forall \langle \Gamma, \Delta \rangle^\tau \in \mathfrak{G}(\mathbf{v})^\tau, C(\langle \Gamma, \Delta \rangle^\tau) \neq p \text{ but } p \in \Delta_{\mathbf{v}}^* \\ \mathbf{u} & \text{if } p \notin \Delta_{\mathbf{v}}^* \end{cases}$$

$$\text{pr}_1(v_C(p)) = \begin{cases} \mathbf{t} & \text{if } \exists \langle \Gamma, \Delta \rangle^\tau \in \mathfrak{G}(\mathbf{v})^\tau \text{ such that } C(\langle \Gamma, \Delta \rangle^\tau) = \dot{\neg} p \\ \mathbf{f} & \text{if } \forall \langle \Gamma, \Delta \rangle^\tau \in \mathfrak{G}(\mathbf{v})^\tau, C(\langle \Gamma, \Delta \rangle^\tau) \neq \dot{\neg} p \text{ but } p \in \Gamma_\mathbf{v}^* \\ \mathbf{u} & \text{if } p \notin \Gamma_\mathbf{v}^* \end{cases}$$

In the sequel, for a Correia model \mathbf{v} , $\mathfrak{F}(\mathbf{v})$ will represent the set containing the NC valuation v_C for every choice function $C \in \prod(\mathfrak{G}(\mathbf{v})^\tau)$.

Now we describe a semantic relation on collections $\mathfrak{F}(\mathbf{v})$ of NC valuations by the following definition:

Definition 5.3.15. $\Gamma \Vdash_{\mathfrak{F}(\mathbf{v})} \Delta$ is defined so that for arbitrary $\Gamma, \Delta \in \mathcal{L}_{\text{zdf}}$, $\Gamma \Vdash_{\mathfrak{F}(\mathbf{v})} \Delta$ if for every AC valuation $v_C \in \mathfrak{F}(\mathbf{v})$, the following holds:

$$v_C([\bigvee \Gamma^\dot{\neg}] \dot{\vee} [\bigvee \Delta]) \in \mathcal{D}_{\text{AC}}.$$

N.b. that inasmuch as Γ and Δ are by definition finite and $\Gamma \cup \Delta$ is nonempty, the formula $[\bigvee \Gamma^\dot{\neg}] \dot{\vee} [\bigvee \Delta]$ is a well defined formula of \mathcal{L}_{zdf} .

Our strategy will be to provide a correspondence between the manipulations of pseudosequents described in Definition 5.3.3 and the features of the relation $\Vdash_{\mathfrak{F}(\mathbf{v})}$. Such a correspondence will permit us to ‘track’ the derivation of a pseudosequent by the truth-functional semantics. As each of these manipulations must be mimicked by the relation $\Vdash_{\mathfrak{F}(\mathbf{v})}$, there are a number of intermediate lemmas that must be established.

Lemma 5.3.7. $\Gamma \Vdash_{\mathfrak{F}(\mathbf{v})} \Delta, \dot{\neg} A$ iff $\Gamma, A \Vdash_{\mathfrak{F}(\mathbf{v})} \Delta$

Proof. First, we note that the commutativity of disjunction in NC entails that $[\bigvee \Gamma^\dot{\neg}] \dot{\vee} [\bigvee \Delta \cup \{\dot{\neg} A\}]$ is truth functionally equivalent to $[\bigvee [\Gamma \cup \{A\}]^\dot{\neg}] \dot{\vee} [\bigvee \Delta]$. Now, $\Gamma \Vdash_{\mathfrak{F}(\mathbf{v})} \Delta, \dot{\neg} A$ is defined so that for all $C \in \prod(\mathfrak{G}(\mathbf{v})^\tau)$, $v_C([\bigvee \Gamma^\dot{\neg}] \dot{\vee} [\bigvee \Delta \cup \{\dot{\neg} A\}]) \in \mathcal{D}_{\text{NC}}$. By the truth functional equivalence of the two formulae, this statement is equivalent to the claim that for all $C \in \prod(\mathfrak{G}(\mathbf{v})^\tau)$, $v_C([\bigvee [\Gamma \cup \{A\}]^\dot{\neg}] \dot{\vee} [\bigvee \Delta]) \in \mathcal{D}_{\text{NC}}$, which is just to say that $\Gamma, A \Vdash_{\mathfrak{F}(\mathbf{v})} \Delta$. \square

Lemma 5.3.8. $\Gamma, \dot{\neg} A \Vdash_{\mathfrak{F}(v)} \Delta$ iff $\Gamma \Vdash_{\mathfrak{F}(v)} \Delta, A$

Proof. This case follows from an argument analogous to that made for Lemma 5.3.7. \square

Lemma 5.3.9. $\Gamma \Vdash_{\mathfrak{F}(v)} \Delta, A \dot{\vee} B$ iff $\Gamma \Vdash_{\mathfrak{F}(v)} \Delta, A, B$

Proof. This is nearly trivial; the formula $\bigvee(\Delta \cup \{A, B\})$ differs from the formula $(\bigvee \Delta) \dot{\vee} (A \dot{\vee} B)$ only by exporting a single disjunct. The commutativity of disjunction in NC ensures the equivalence of the two formulae. \square

Lemma 5.3.10. $\Gamma, A \dot{\wedge} B \Vdash_{\mathfrak{F}(v)} \Delta$ iff $\Gamma, A, B \Vdash_{\mathfrak{F}(v)} \Delta$

Proof. This follows from an argument analogous to that made for Lemma 5.3.9. \square

Lemma 5.3.11. $\Gamma \Vdash_{\mathfrak{F}(v)} \Delta, A \dot{\wedge} B$ iff $\Gamma \Vdash_{\mathfrak{F}(v)} \Delta, A$ and $\Gamma \Vdash_v \Delta, B$

Proof. For left-to-right, suppose that for all $C \in \prod(\mathfrak{G}(v)^\tau)$, $v_C([\bigvee \Gamma^\dot{\neg}] \dot{\vee} [[\bigvee \Delta] \dot{\vee} (A \dot{\wedge} B)]) \in \mathcal{D}_{\text{NC}}$; then in any such v_C , it follows that both $v_C([\bigvee \Gamma^\dot{\neg}] \dot{\vee} [[\bigvee \Delta] \dot{\vee} A]) \in \mathcal{D}_{\text{NC}}$ and $v_C([\bigvee \Gamma^\dot{\neg}] \dot{\vee} [[\bigvee \Delta] \dot{\vee} B]) \in \mathcal{D}_{\text{NC}}$. This is just to say that $\Gamma \Vdash_{\mathfrak{F}(v)} \Delta, A$ and $\Gamma \Vdash_{\mathfrak{F}(v)} \Delta, B$.

For right-to-left, suppose for contradiction that both $\Gamma \Vdash_{\mathfrak{F}(v)} \Delta, A$ and $\Gamma \Vdash_{\mathfrak{F}(v)} \Delta, B$ hold although there exists an $C' \in \prod(\mathfrak{G}(v)^\tau)$ such that $v_{C'}([\bigvee \Gamma^\dot{\neg}] \dot{\vee} [[\bigvee \Delta] \dot{\vee} (A \dot{\wedge} B)]) \notin \mathcal{D}_{\text{NC}}$. Hence, $v_{C'}([\bigvee \Gamma^\dot{\neg}] \dot{\vee} [\bigvee \Delta]) \notin \mathcal{D}_{\text{NC}}$ and $v_{C'}(A \dot{\wedge} B) \notin \mathcal{D}_{\text{NC}}$. By hypothesis, $v_{C'}([\bigvee \Gamma^\dot{\neg}] \dot{\vee} [[\bigvee \Delta] \dot{\vee} A]) \in \mathcal{D}_{\text{NC}}$ and $v_{C'}([\bigvee \Gamma^\dot{\neg}] \dot{\vee} [[\bigvee \Delta] \dot{\vee} B]) \in \mathcal{D}_{\text{NC}}$, entailing that $v_{C'}(A) \in \mathcal{D}_{\text{NC}}$ and $v_{C'}(B) \in \mathcal{D}_{\text{NC}}$, which entails that $v_{C'}(A \dot{\wedge} B) \in \mathcal{D}_{\text{NC}}$, contradicting our earlier assumption that $v_{C'}(A \dot{\wedge} B) \notin \mathcal{D}_{\text{NC}}$. \square

Lemma 5.3.12. $\Gamma, A \dot{\vee} B \Vdash_{\mathfrak{F}(v)} \Delta$ iff $\Gamma, A \Vdash_{\mathfrak{F}(v)} \Delta$ and $\Gamma, B \Vdash_{\mathfrak{F}(v)} \Delta$

Proof. The structure of this follows the proof of Lemma 5.3.11 identically. \square

We have nearly sufficient material to demonstrate that for every valid inference $A \vDash_{\text{AC}} B$, the inference $A \vDash_{\text{NC}} B$ is also valid. There remain a few further lemmas to establish.

Lemma 5.3.13. *For all $\Gamma, \Delta \in \mathcal{L}_{\text{zdf}}$ and vocabulary closed Correia models \mathbf{v} ,*

$$\Gamma \Vdash_{\mathfrak{F}(\mathbf{v})} \Delta \text{ iff } \Gamma \Vdash_{\mathbf{v}} \Delta.$$

Proof. To begin, we first observe that for all sets $\Gamma, \Delta \subset \mathbf{At}$, the equivalence between $\Gamma \Vdash_{\mathfrak{F}(\mathbf{v})} \Delta$ and $\Gamma \Vdash_{\mathbf{v}} \Delta$ holds. Consider the assertion that $\Gamma \Vdash_{\mathfrak{F}(\mathbf{v})} \Delta$, *i.e.*, that for all NC valuations $v_C \in \mathfrak{F}(\mathbf{v})$, $v_C([\bigvee \Gamma^{\dot{\cdot}}] \dot{\vee} [\bigvee \Delta]) \in \mathcal{D}_{\text{NC}}$. This assertion is itself equivalent to the claim that for every selection function $C \in \prod(\mathfrak{G}(\mathbf{v})^\tau)$ there exists some Correia pair $\langle \Gamma', \Delta' \rangle \in \mathfrak{G}(\mathbf{v})$ such that $C(\langle \Gamma', \Delta' \rangle^\tau) \in \Gamma^{\dot{\cdot}} \cup \Delta$. This property holds if and only if there exist Correia pairs $\langle \Gamma_0, \Delta_0 \rangle, \dots, \langle \Gamma_{n-1}, \Delta_{n-1} \rangle \in \mathfrak{G}(\mathbf{v})$ such that $\cup_{i < n} \Gamma_i = \Gamma$ and $\cup_{i < n} \Delta_i = \Delta$. By vocabulary closure of \mathbf{v} , this statement is equivalent to the condition that $\bigvee_{i < n} \langle \Gamma_i, \Delta_i \rangle \in \mathbf{v}$. But this condition is precisely to say that $\langle \Gamma, \Delta \rangle \in \mathbf{v}$, a statement that we may recognize as the definition of $\Gamma \Vdash_{\mathbf{v}} \Delta$.

Before beginning the induction, it is furthermore important to observe that for arbitrary Γ and Δ , whenever $\Gamma \Vdash_{\mathbf{v}} \Delta$ there exists a finite sequence σ of pseudosequents such that the initial element of σ is $\Gamma_0 \Vdash_{\mathbf{v}} \Delta_0$ where $\Gamma_0, \Delta_0 \subset \mathbf{At}$ and the terminal element of σ is the pseudosequent $\Gamma \Vdash_{\mathbf{v}} \Delta$. Moreover, for any n less than the length of σ , the n th pseudosequent appearing in σ follows from the $n - 1$ th pseudosequent by the application of one of the manipulations described in Definition 5.3.3.

With this observation, we may proceed to prove the lemma by induction on the length of such sequences. Because in any initial pseudosequent $\langle \Gamma_0, \Delta_0 \rangle$, $\Gamma_0 \cup \Delta_0 \subseteq \mathbf{At}$, the basis step for the induction—that is, the case in which only one pseudosequent appears in the sequence σ —is established by the previously observed equivalence of $\Gamma_0 \Vdash_{\mathfrak{F}(\mathbf{v})} \Delta_0$ and $\Gamma_0 \Vdash_{\mathbf{v}} \Delta_0$.

Now, let $\Gamma_n \Vdash_{\mathbf{v}} \Delta_n$ be the n th pseudosequent of a sequence σ and suppose as induction hypothesis that the equivalence holds for pseudosequents appearing earlier in σ . In particular, the induction hypothesis entails that for the $n - 1$ th pseudosequent, the following holds:

$$\Gamma_{n-1} \Vdash_{\mathbf{v}} \Delta_{n-1} \text{ iff } \Gamma_{n-1} \Vdash_{\mathfrak{F}(\mathbf{v})} \Delta_{n-1}$$

Now, the n th pseudosequent $\Gamma_n \Vdash_{\mathbf{v}} \Delta_n$ is derived from $\Gamma_{n-1} \Vdash_{\mathbf{v}} \Delta_{n-1}$ by the application of one of Correia's manipulation rules. But Lemmas 5.3.7–5.3.12 jointly ensure that the application any one of these rules is mirrored by the relation $\Vdash_{\mathfrak{F}(\mathbf{v})}$. Hence:

$$\Gamma_n \Vdash_{\mathbf{v}} \Delta_n \text{ iff } \Gamma_{n-1} \Vdash_{\mathbf{v}} \Delta_{n-1} \text{ iff } \Gamma_{n-1} \Vdash_{\mathfrak{F}(\mathbf{v})} \Delta_{n-1} \text{ iff } \Gamma_n \Vdash_{\mathfrak{F}(\mathbf{v})} \Delta_n$$

This establishes the equivalence between $\Gamma_n \Vdash_{\mathbf{v}} \Delta_n$ and $\Gamma_n \Vdash_{\mathfrak{F}(\mathbf{v})} \Delta_n$. Because any derivable pseudosequent appears as the m th pseudosequent in a finite sequence σ , this equivalence holds for arbitrary derivable pseudosequents $\Gamma \Vdash_{\mathbf{v}} \Delta$. \square

Now we are prepared to prove the theorem.

Theorem 5.3.2. *If $A \vDash_{\text{NC}} B$ then $A \vDash_{\text{AC}} B$*

Proof. We prove the contrapositive. Suppose that $A \not\vDash_{\text{AC}} B$. Then there exists a vocabulary closed Correia model \mathbf{v} such that $\emptyset \Vdash_{\mathbf{v}} A$ and $\emptyset \not\Vdash_{\mathbf{v}} B$. By Lemma 5.3.13, this assertion entails that $\emptyset \Vdash_{\mathfrak{F}(\mathbf{v})} A$, which in turn implies that for all choice functions $C \in \prod(\mathfrak{G}(\mathbf{v})^\tau)$, $v_C(A) \in \mathcal{D}_{\text{NC}}$. But identical reasoning yields that it is not the case that $\emptyset \Vdash_{\mathfrak{F}(\mathbf{v})} B$, entailing the existence of some valuation $v_{C'} \in \mathfrak{F}(\mathbf{v})$ such that $v_{C'}(B) \notin \mathcal{D}_{\text{NC}}$. As $v_{C'}(A) \in \mathcal{D}_{\text{NC}}$, $v_{C'}$ witnesses that $A \not\vDash_{\text{NC}} B$. \square

Corollary 5.3.1. $\text{AC} = \text{NC}$

Proof. By Theorem 5.3.1, AC is a subsystem of NC ; Theorem 5.3.2 proves the converse. Hence, $\text{AC} = \text{NC}$. \square

With this reassurance, we are free to abandon talk of NC and may use the nomenclature AC to describe the nine-valued semantics. For example, we will use the symbol \vDash_{AC} in the sequel to denote consequence with respect to the semantics of Definition 5.2.3.

In addition to admitting a Belnap-style interpretation of AC, the nine-valued semantics makes a further type of interpretation available. We have noted that AC bears an identical relationship to Bochvar's Σ_0 to that which E_{fde} bears to classical logic. In (199), Peter Woodruff remarks that a 'popular explication' of Halldén-type nonsense logics, (*e.g.*, Bochvar's Σ_0) lies in interpreting the truth functions as partial functions, as suggested by Kleene in (122) when describing the matrices for Σ_0 . If we understand the semantical functions of AC bilaterally, that is, as a pair of Σ_0 truth functions independently calculating values corresponding to truth and falsity, the semantics of Definition 5.2.3 opens AC to a similar partial function interpretation.

5.4 Steps Forward

The simplicity of the above semantics for AC does more than merely to provide a novel way to interpret the system. It also has a formal upshot in permitting us to address some formal questions in a simple fashion. For one, we can give a particular type of 'double-barrelled analysis' of AC (and S_{fde}^*), the availability of which is *not* apparent in the Correia semantics. Moreover, the nine-valued semantics suggests a natural adaptation of Fine's semantics for PAI of Definition 2.4.1 in a way that provides an account of higher-degree extensions of AC (as well as such extensions of S_{fde}^*).

5.4.1 The Gödel-Fine Analysis of AC

Recall the definition of a Gödel-Fine analysis of a deductive system L in Section 4.1.2. Virtually every containment logic, *e.g.*, Harry Deutsch's S (of (59)), can receive such a characterization. In addition to the analyses described in Section 4.1.2, the many-valued semantics for AC enable us to provide the Gödel-Fine analysis of AC.

Observation 5.4.1. $A \vDash_{\text{AC}} B$ iff $\left\{ \begin{array}{l} A \vDash_{E_{\text{fde}}} B, \\ \mathbf{At}^+(B) \subseteq \mathbf{At}^+(A), \text{ and} \\ \mathbf{At}^-(B) \subseteq \mathbf{At}^-(A) \end{array} \right.$

Proof. The left-to-right direction is proven in (11). For right-to-left, then, suppose that $A \vDash_{E_{\text{fde}}} B$ and both $\mathbf{At}^+(B) \subseteq \mathbf{At}^+(A)$ and $\mathbf{At}^-(B) \subseteq \mathbf{At}^-(A)$ hold. Suppose for contradiction that $A \not\vDash_{\text{AC}} B$.

Let v be an AC valuation witnessing this fact. Then from $v(A) \in \mathcal{D}_{\text{AC}}$ it follows from Lemma 5.2.2 that both $\mathbf{u} \notin \text{pr}_0[v[\mathbf{At}^+(A)]]$ and $\mathbf{u} \notin \text{pr}_1[v[\mathbf{At}^-(A)]]$. Moreover, that $\mathbf{At}^+(B) \subseteq \mathbf{At}^+(A)$ and $\mathbf{At}^-(B) \subseteq \mathbf{At}^-(A)$ entails that the same can be said of B . By employing the construction in Lemma 5.3.4, we can build an E_{fde} valuation v'' such that $v''(A) \in \mathcal{D}_{E_{\text{fde}}}^*$ and $v''(B) \notin \mathcal{D}_{E_{\text{fde}}}^*$, i.e., $A \not\vDash_{E_{\text{fde}}} B$. \square

Observation 5.4.1 has been independently established by Fine in (87), although its statement is expressed in significantly different terms.

These analyses allow us to make a further observation concerning S_{fde}^* 's relationship with the field of containment logics. Just as E_{fde} is the first-degree fragment of E , Parry's PAI has a distinct first-degree fragment. As Sylvan suggested in (166), the first-degree fragment PAI_{fde} appeared in Aleksandr Zinov'ev's (202) as the system S_1 , the semantics of which were given as a tacit Gödel-Fine analysis:

$$A \vDash_{S_1} B \text{ iff } \left\{ \begin{array}{l} A \vDash_{\text{CL}} B, \text{ and} \\ \mathbf{At}(B) \subseteq \mathbf{At}(A) \end{array} \right.$$

where \vDash_{CL} denotes classical entailment. Clearly, S_{fde}^* counts Angell's AC as a subsystem, but the analysis of Observation 4.1.1 allows us to prove the equivalence between the many-valued semantics for S_{fde}^* in Definition 4.1.5 and the two proof-theoretic characterizations due to Angell (in (9)) and Daniels (in (55)).

As we noted in Section 4.1.2, the first appearance of a deductive system equivalent to S_{fde}^* is found in Angell’s abstract (9), in which Angell provides an axiomatization of the intersection of E_{fde} and PAI_{fde} . Although it has not been mentioned in the literature—much less proven—consequence in S_{fde}^* in fact corresponds to consequence in the intersection $E_{fde} \cap PAI_{fde}$. By invoking the equivalence of PAI_{fde} and S_1 , Observation 4.1.1 immediately implies the following corollary:

Corollary 5.4.1. $S_{fde}^* = E_{fde} \cap PAI_{fde}$

In (9), Angell also remarks that the logic $E_{fde} \cap PAI_{fde}$ is axiomatized by adding the axiom $A \vdash A \dot{\vee} \dot{\wedge} A$ to AC. This gives us the following proof-theoretic corollary:

Corollary 5.4.2. $S_{fde}^* = AC + A \vdash A \dot{\vee} \dot{\wedge} A$

We have also observed that S_{fde}^* is syntactically introduced by Daniels in (55), in which it is asserted that S_{fde}^* is the first-degree fragment of the logic corresponding to Daniels’ ‘story semantics’ of (54). Daniels provides a tacit Gödel-Fine analysis in his syntactic definition of S_{fde}^* according to which validity of an inference $A \vdash_{S_{fde}^*} B$ is defined as the validity of the inference $A \vdash_{E_{fde}} B$ in conjunction with the condition that $\mathbf{At}(B) \subseteq \mathbf{At}(A)$. This gives us a further corollary:

Corollary 5.4.3. *The system described by Daniels in (55) corresponds to the five-valued semantics for S_{fde}^**

These analyses will be reflected in the semantics as we move to higher degree systems.

5.4.2 Extending to Higher Degree Formulae

One of Correia’s suggestions in (49) as an interesting topic future research on AC was to provide an intuitive means of extending the first-degree system to account for the language with formulae containing nested conditionals. By the present semantics for AC, we are

provided with a very natural means of defining such an extension. In Definition 2.4.4, we observed that subsystems of PAI could be described by relaxing certain conditions implicit in Fine’s semantics for Parry’s PAI of (81). Just as relaxing the requirement of consistency for PAI models yielded semantics for Deutsch’s S introduce two higher degree systems, by further weakening PAI models, we can define semantics for systems PAC (for ‘Parry-like’ AC) and PFDE_φ (for ‘Parry-like’ FDE_φ).⁵

We will not offer axiomatizations for the systems introduced in this section, although the proximity to Fine’s semantics suggests that his canonical model construction can be easily adapted for soundness and completeness proofs. Our goal is merely to outline a very reasonable way of treating such systems that is harmonious with the prevailing treatments of other containment logics.

The logic PAI is defined over the language \mathcal{L}_+ defined in Definition 1.1.1 so that formulae may contained nested instances of the intensional conditional. Working in a richer language compels us to extend the definition of functions $\mathbf{At}^+(A)$ and $\mathbf{At}^-(A)$ from Definition 5.2.5 to accommodate higher degree formulae. We enrich the definition of these functions by adding the clauses:

- $\mathbf{At}^+(A \rightarrow B) = \mathbf{At}^+(A) \cup \mathbf{At}^+(B)$
- $\mathbf{At}^-(A \rightarrow B) = \mathbf{At}^-(A) \cup \mathbf{At}^-(B)$

To produce a semantics for logics the first-degrees of which correspond to AC or S_{fde}^* , we continue the trend from Definition 2.4.1 to Definition 2.4.4 and define an even weaker version of Fine’s semantics of (81). We will call the structure central to this section a PAC model.

Definition 5.4.1. *A PAC model is a 5-tuple $\langle W, R, C, \Gamma, V \rangle$ where:*

- *W is a nonempty set of points*

⁵Constancy might suggest that PS_{fde}^* would be a more appropriate name for the Parry-like extension of S_{fde}^* . But the system has been introduced in print as PFDE_φ and we will retain that nomenclature now.

- $R \subseteq W \times W$ is reflexive and transitive

For each $w \in W$ there exists a semilattice $C_w \in \mathbf{C}$ where $C_w = \langle C_w, \circ_w \rangle$, so that:

- C_w is a nonempty set
- \circ_w is an associative, commutative, and idempotent function on C_w

Because C_w is a semilattice, each induces a relation \leq_w so that for all $a, b \in C_w$, $a \leq_w b$ if $a \circ_w b = b$. Finally,

- for all $w \in W$, the set Γ contains a pair of functions γ_w^+ and γ_w^- from \mathbf{At} to C_w
- V includes two functions V^+ and V^- from \mathbf{At} to $\wp(W)$

For each point w , from functions γ_w^+ and γ_w^- we construct a function $\gamma_w : \mathcal{L}_+ \rightarrow C_w$ so that for an arbitrary formula $A \in \mathcal{L}_+$:

- $\gamma_w(A) = \gamma_w^+(p_0) \circ_w \dots \circ_w \gamma_w^+(p_{m-1}) \circ_w \gamma_w^-(q_0) \circ_w \dots \circ_w \gamma_w^-(q_{n-1})$

where $\{p_0, \dots, p_{m-1}\} = \mathbf{At}^+(A)$ and $\{q_0, \dots, q_{n-1}\} = \mathbf{At}^-(A)$.

The two valuation functions V^+ and V^- in the presentation of Fine's semantics found in Definition 2.4.1 were included in anticipation of the requirement in Definition 2.4.4 that *truth* and *falsity* are treated independently. In splitting Fine's γ_w into γ_w^+ and γ_w^- , we make an analogous revision in which positive negative *concepts* are treated independently. It is worth noting that this distinction reflects Fine's bilateral account of subject-matter discussed in Section 3.1.2, in which a proposition enjoys distinct positive and negative subject-matters.

We give truth and falsity conditions, represented by \Vdash^+ and \Vdash^- , respectively.

Definition 5.4.2. *The positive forcing relation \Vdash^+ is defined for all formulae so that:*

- $w \Vdash^+ A$ if $w \in V^+(A)$ for $A \in \mathbf{At}$

- $w \Vdash^+ \neg A$ if $w \Vdash^- A$
- $w \Vdash^+ A \dot{\wedge} B$ if $w \Vdash^+ A$ and $w \Vdash^+ B$
- $w \Vdash^+ A \dot{\vee} B$ if $w \Vdash^+ A$ or $w \Vdash^+ B$
- $w \Vdash^+ A \rightarrow B$ if $\forall w' \in W$ s.t. wRw' , $\left\{ \begin{array}{l} w' \Vdash^+ A \text{ implies } w' \Vdash^+ B \text{ and} \\ \gamma_{w'}(B) \leq_{w'} \gamma_{w'}(A) \end{array} \right.$

The negative relation is defined so that:

- $w \Vdash^- A$ if $w \in V^-(A)$
- $w \Vdash^- \neg A$ if $w \Vdash^+ A$
- $w \Vdash^- A \dot{\wedge} B$ if $w \Vdash^- A$ and $w \Vdash^- B$
- $w \Vdash^- A \dot{\vee} B$ if $w \Vdash^- A$ and $w \Vdash^- B$
- $w \Vdash^- A \rightarrow B$ if $\exists w' \in W$ s.t. wRw' and $\left\{ \begin{array}{l} w' \Vdash^+ A \text{ and } w' \Vdash^- B \text{ or} \\ \gamma_{w'}(B) \not\leq_{w'} \gamma_{w'}(A) \end{array} \right.$

We call the system determined by these semantics PAC:

Definition 5.4.3. *The system PAC is defined so that $\Gamma \vDash_{\text{PAC}} A$ if for every point w in every PAC model, whenever $w \Vdash^+ B$ for all $B \in \Gamma$, also $w \Vdash^+ A$.*

We are able to show that PAC extends AC in the desired fashion.

Observation 5.4.2. *AC is the first-degree fragment of PAC*

Proof. To show that $A \vDash_{\text{AC}} B$ entails that $\vDash_{\text{PAC}} A \rightarrow B$, we prove the contrapositive. Suppose for zeroth degree formulae A, B that $\not\vDash_{\text{PAC}} A \rightarrow B$. Then there exists a point w in a model such that $w \not\Vdash^+ A \rightarrow B$. Hence, there exists a w' such that wRw' at which either $w' \Vdash^+ A$ and $w' \not\Vdash^+ B$ or $\gamma_{w'}(A) \not\leq_{w'} \gamma_{w'}(B)$.

In the former case, we can build an \mathbf{E}_{fde} valuation showing that $A \not\vdash_{\mathbf{E}_{\text{fde}}} B$. Let u be a bilateral \mathbf{E}_{fde} valuation defined so that for all $p \in \mathbf{At}$,

$$u(p) = \begin{cases} \langle \mathbf{t}, \mathbf{t} \rangle & \text{if } w' \in V^+(p) \text{ and } w' \in V^-(p) \\ \langle \mathbf{t}, \mathbf{f} \rangle & \text{if } w' \in V^+(p) \text{ and } w' \notin V^-(p) \\ \langle \mathbf{f}, \mathbf{t} \rangle & \text{if } w' \notin V^+(p) \text{ and } w' \in V^-(p) \\ \langle \mathbf{f}, \mathbf{f} \rangle & \text{if } w' \notin V^+(p) \text{ and } w' \notin V^-(p) \end{cases}$$

That $u[\mathbf{At}] \subseteq \mathcal{V}_{\mathbf{E}_{\text{fde}}}^*$ entails that the above is a bilateral \mathbf{E}_{fde} valuation. A simple induction on complexity of formulae shows that for zeroth degree formulae C , $u(C) \in \mathcal{D}_{\mathbf{E}_{\text{fde}}}^*$ if and only if $w' \Vdash^+ C$. As A and B have no instances of the intensional implication connective, this entails that $A \not\vdash_{\mathbf{E}_{\text{fde}}} B$. But as \mathbf{AC} is a subsystem of \mathbf{E}_{fde} , this entails that $A \not\vdash_{\mathbf{AC}} B$.

In the latter case, $\gamma_{w'}(A) \not\leq_{w'} \gamma_{w'}(B)$. This may occur only if there is an atom p such that either $p \in \mathbf{At}^+(B)$ and $p \notin \mathbf{At}^+(A)$ or $p \in \mathbf{At}^-(B)$ and $p \notin \mathbf{At}^-(A)$. Suppose without loss of generality that the former holds and construct an \mathbf{E}_{fde} valuation u defined as above with the sole exception that $\text{pr}_0(u(p)) = \mathbf{u}$. The valuation u will thus map A to $\mathcal{D}_{\mathbf{AC}}$; however, by Lemma 5.2.2, the conjunction of the fact that p appears positively in B and the fact that $\text{pr}_0(u(p)) = \mathbf{u}$ implies that $u(B) \notin \mathcal{D}_{\mathbf{AC}}$, *i.e.*, $A \not\vdash_{\mathbf{AC}} B$.

In both cases we conclude $A \not\vdash_{\mathbf{AC}} B$, hence, that $\not\vdash_{\mathbf{PAC}} A \rightarrow B$ entails that $A \not\vdash_{\mathbf{AC}} B$.

To prove that $\vdash_{\mathbf{PAC}} A \rightarrow B$ entails that $A \vdash_{\mathbf{AC}} B$ for $A, B \in \mathcal{L}_{\text{zdf}}$, suppose that $A \not\vdash_{\mathbf{AC}} B$ and let u be an \mathbf{AC} valuation that witnesses this fact. We construct a \mathbf{PAC} model witnessing the failure of $A \rightarrow B$ in \mathbf{PAC} . For an atomic formula q , let p_q represent the pair $\langle \ulcorner q \urcorner, 0 \rangle$ and let m_q represent the pair $\langle \ulcorner q \urcorner, 1 \rangle$, so that p_q and m_q are pairs comprising the syntactic object itself and with a natural number standing in for its polarity. Now, let W be a singleton $\{w\}$ and let $C_w = \wp(\{p_q \mid q \in \mathbf{At}^+(A \dot{\wedge} B)\} \cup \{m_q \mid q \in \mathbf{At}^-(A \dot{\wedge} B)\})$ with \circ_w interpreted as set theoretic union.

Construct valuations V^+ and V^- so that for all $q \in \mathbf{At}$,

- $w \in V^+(A)$ iff $\text{pr}_0(u(q)) = \mathbf{t}$
- $w \in V^-(A)$ iff $\text{pr}_1(u(q)) = \mathbf{t}$

and construct functions γ_w^+ and γ_w^- so that for all $q \in \mathbf{At}$,

$$\bullet \gamma_w^+(q) = \begin{cases} \{p_q\} & \text{if } q \in \mathbf{At}^+(A \dot{\wedge} B) \\ \emptyset & \text{otherwise} \end{cases}$$

$$\bullet \gamma_w^-(C) = \begin{cases} \{m_q\} & \text{if } q \in \mathbf{At}^-(A \dot{\wedge} B) \\ \emptyset & \text{otherwise} \end{cases}$$

By the Gödel-Fine analysis of AC in Observation 5.4.1, that $A \not\vdash_{\text{AC}} B$ entails that one of three conditions holds: Either $A \not\vdash_{\text{Fde}} B$, $\mathbf{At}^+(B) \not\subseteq \mathbf{At}^+(A)$, or $\mathbf{At}^-(B) \not\subseteq \mathbf{At}^-(A)$. We prove the observation by arguing by cases.

In the first case, the valuation u serves as a bilateral E_{fde} valuation witnessing the failure of the inference from A to B . Now, because A and B have no instances of the implication connective, that $u(A) \in \mathcal{D}_{\text{AC}}$ and $u(B) \notin \mathcal{D}_{\text{AC}}$ entails that $w \Vdash^+ A$ and $w \not\Vdash^+ B$. As wRw , this entails that $w \not\Vdash^+ A \rightarrow B$, whence we infer that $\not\vdash_{\text{PAC}} A \rightarrow B$.

The latter two cases are symmetrical. Hence, we examine the first, in which $\mathbf{At}^+(B) \not\subseteq \mathbf{At}^+(A)$, without loss of generality. If this is the case, then there exists some $q \in \mathbf{At}^+(B)$ not appearing positively in A . But this means that $p_q \in \gamma_w(B)$ but $p_q \notin \gamma_w(A)$. As \circ_w is interpreted in our example as set-theoretical union, this entails that $\gamma_w(B) \not\subseteq_w \gamma_w(A)$, entailing that $w \not\Vdash^+ A \rightarrow B$.

From the assumption that $A \not\vdash_{\text{AC}} B$ we thus conclude that $\not\vdash_{\text{PAC}} A \rightarrow B$. By contraposition, that $A \rightarrow B$ is a PAC theorem entails that $A \vdash_{\text{AC}} B$ is a valid inference. \square

A simple restriction to the semantics yields the analogous extension for S_{fde}^* .

Definition 5.4.4. *The system PFDE_φ is defined so that $\Gamma \vDash_{\text{PFDE}_\varphi} A$ if for all PAC models enjoying the property that*

$$\gamma_w^+(p) = \gamma_w^-(p) \text{ for all } p \in \mathbf{At}$$

if $w \Vdash^+ B$ for all $B \in \Gamma$, also $w \Vdash^+ A$.

We may also confirm that PFDE_φ extends S_{fde}^* in the desired fashion.

Observation 5.4.3. *S_{fde}^* is the first-degree fragment of PFDE_φ .*

Proof. The proof is virtually identical to that of Observation 5.4.2. □

We may observe that the definition of a PAC model gives a great deal of flexibility; there are three degrees of freedom by which we may restrict models to yield stronger systems, *i.e.*, by adding restrictions to any of Γ , V , and R , we can generate corresponding extensions of PAC.

For example, considering validity in the restricted class of PAC in which for all $p \in \mathbf{At}$ and $w \in W$, both $\gamma_w^+(p) = \gamma_w^-(p)$ and $V^+(p) \cup V^-(p) = W$ yields Harry Deutsch’s paraconsistent containment logic S from (59). The various definitions from Section 4.1.1 entail that adding the further restriction to this class models so that we consider only models in which R linearly orders W will yield Deutsch’s S' introduced in (61), while adding the additional restriction that W is a singleton will correspond to a ‘demodalized’ extension S'' . Of course, adding the restriction that for all $p \in \mathbf{At}$, $V^+(p) \cap V^-(p) = \emptyset$ to the restrictions that characterized S will yield Fine’s original semantics for PAI in Definition 2.4.1. Finally, restricting the class of PAI models to those in which W is a singleton yields Dunn’s demodalized containment logic DAI, introduced in (65) and rediscovered by Richard Epstein with different (set-assignment) semantics as ‘D’ in (69). Figure 5.1 portrays the relationship between various intensional containment logics, arranged by which of γ , V , or R is restricted.

Moreover, it is also clear that one could also define ‘demodalized’ versions of PAC and PFDE_φ . Examining this structure in more detail and providing an axiomatic account of these relationships is an interesting task, although a task left for future study.

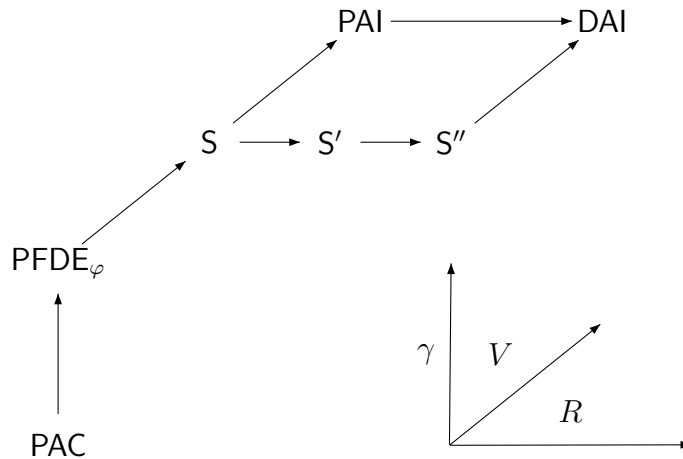

Figure 5.1: Systems Intermediate Between PAC and DAI

5.5 Conclusion

The present work goes some way towards providing S_{fde}^* and AC with a robust and useful interpretation, as well as addressing some formal questions. We conclude with some suggestions for future research.

It would be interesting to find ways to extend the present approach to some of the first-degree logics near AC. For example, the only authentically semantical presentation of S_1 —presented in (121), in which Kielkopf proves that S_1 is characterized by the matrices Parry uses in (143) to prove consistency of AI—is rather unintuitive. In addition to examining $E_{fde} \cap S_1$ —which we saw to be S_{fde}^* —Angell’s (9) also gives an axiomatic account of the system $E_{fde} \cup S_1$. What semantics exist for *this* system and how could they be interpreted?

The intensional containment logics intermediate between PAC and DAI are left largely unexamined and questions remain unanswered. What relationship exists between restricting γ , v , and R ? What are the axiomatizations of these systems? Is there a way to provide a more elegant axiomatization of S and S' than was offered by Deutsch? I suspect that the

structure of these intermediate systems is a rich one, worthy of exploration.

A further topic worthy of investigating is examining faulty *networks* of Belnap computers. In (175), Yaroslav Shramko and Heinrich Wansing ask how to extend the Belnapian picture to a network of such systems. In particular, Shramko and Wansing discover that the sixteen-valued logic of such a network determines the same consequence relation as does the four-valued semantics for E_{fde} ; furthermore, this result extends to networks of such networks, and networks of networks of networks, *ad infinitum*. As a deductive system, E_{fde} is thus *stable* in a strong sense. Exploring suitable generalizations of the faulty Belnap computer to faulty Shramko-Wansing networks and asking whether S_{fde}^* and AC are stable in the same sense as E_{fde} are very intriguing topics, which are examined to some degree in the following chapter.

Chapter 6

Cut-Down Operations on Multilattices

In Section 4.2.4, we considered Melvin Fitting’s ‘cut-down’ connectives—propositional connectives that ‘cut down’ available evidence—in the context of containment logics. We now return to examine this relationship more closely. The work of Arnon Avron and Ofer Arieli has shown a deep relationship between the theory of bilattices and the Belnap-Dunn logic E_{fde} . This correspondence has been interpreted as evidence that E_{fde} is ‘the’ logic of bilattices, a consideration reinforced by the work of Yaroslav Shramko and Heinrich Wansing in which E_{fde} is shown to be similarly entrenched with respect to the theories of *trilattices* and, more generally, multilattices. In this chapter, we export Fitting’s ‘cut-downs’ to the case of multilattices and show that two related first-degree systems—the Deutsch-Oller system S_{fde} and Richard Angell’s AC—emerge just as elegantly and are as intimately connected to the theory of multilattices as the Belnap-Dunn logic.

6.1 Introduction: Bilattices and Cut-Downs

Recall from Section 4.2.4 Fitting’s epistemic interpretation of the operations of Bochvar’s ‘internal’ logic Σ_0 (equivalent to Kleene’s weak three-valued logic). In this section, we will examine the generalization of cut-down operations and study how such cut-down operations behave in the context of multilattices. Two types of cut-downs will be considered, and the logic of such operations will be described.

Bilattices were introduced by Matthew Ginsberg in (96) and (97) as a formal tool in which to model aspects of reasoning in artificial intelligence. The study of bilattices was also taken up by Fitting (*e.g.*, (89), (91)), in which a bilattice is treated as a generalized truth-value space with applications to logic programming and the theory of truth.

Definition 6.1.1. A bilattice \mathcal{B} is a structure $\langle B, \leq_t, \leq_k, \neg \rangle$ where:

- B is a nonempty set
- \leq_t and \leq_k are partial orderings of B such that both $\langle B, \leq_k \rangle$ and $\langle B, \leq_t \rangle$ are complete lattices
- $\neg : B \rightarrow B$ is a inversion such that
 - $\neg\neg a = a$
 - If $a \leq_t b$ then $\neg b \leq_t \neg a$
 - If $a \leq_k b$ then $\neg a \leq_k \neg b$

N.b. that the original definition of a bilattice does not include the clause stipulating the existence of an inversion \neg . Following the work of Fitting (*e.g.*, (89), (90), (91)) and Arieli and Avron (*e.g.*, (12), (13), (14)), the stipulation that such a function exists has become standard. In current parlance, structures defined like the above definition bilattice without the stipulation that a negation operation exists are called ‘prebilattices.’

The orderings \leq_t and \leq_k are often referred to as the ‘truth’ and ‘information’ orderings, respectively, representing an increase in the degree of truth and the amount of information. Meet and join with respect to \leq_t are denoted by ‘ \wedge ’ and ‘ \vee ’ while meet and join with respect to \leq_k are denoted by ‘ \otimes ’ and ‘ \oplus ,’ respectively. Moreover, the definition assumes that for all bilattices \mathcal{B} and $a, b \in B$, meets and joins modulo both \leq_k and \leq_t exist and that there exist distinct tops and bottoms modulo each relation.

Definition 6.1.2. *With respect to two lattices \mathcal{A}, \mathcal{B} with orderings $\leq_{\mathcal{A}}$ and $\leq_{\mathcal{B}}$, respectively, the Ginsberg-Fitting product $\mathcal{A} \odot \mathcal{B}$ is a bilattice $\langle A \times B, \leq_t, \leq_k, \neg \rangle$ where for $\langle a_0, b_0 \rangle, \langle a_1, b_1 \rangle \in A \times B$:*

- $\langle a_0, b_0 \rangle \leq_k \langle a_1, b_1 \rangle$ iff $a_0 \leq_{\mathcal{A}} a_1$ and $b_0 \leq_{\mathcal{B}} b_1$
- $\langle a_0, b_0 \rangle \leq_t \langle a_1, b_1 \rangle$ iff $a_0 \leq_{\mathcal{A}} a_1$ and $b_1 \leq_{\mathcal{B}} b_0$
- $\neg \langle a_0, b_0 \rangle = \langle b_0, a_0 \rangle$

Definition 6.1.3. *The set $[a, b]_k = \{x \in B \mid a \leq_k x \leq_k b\}$.*

Definition 6.1.4. *A bilattice \mathcal{B} is bilinear if \mathcal{B} is isomorphic to a bilattice $\mathcal{L} \odot \mathcal{L}$, where $\langle \mathcal{L}, \leq_{\mathcal{L}} \rangle$ is a linear order.*

In (90), Fitting studies a logic including a binary ‘guard connective,’ from which the weak operations of Kleene are definable. However, Fitting’s (91) gives an equivalent formalization of these weak operations in terms of ‘cut-down’ operations which can be defined in terms of the standard bilattice operations. First-degree systems in which conjunction and disjunction are interpreted as cut-down operations on bilattices are the targets of this chapter.

In (91), Fitting offers an epistemically-rich interpretation of the Kleene/Bochvar logic in which groups of experts opining on propositions serve in place of truth-values. The truth value assigned to a conjunction $\varphi \wedge \psi$, *e.g.*, is interpreted as a pair comprising a group of

experts who assent to both φ and ψ and a group of experts opposing either φ or ψ . But, as Fitting notes, it is a truism that not all experts have opinions on all matters; hence, within this interpretation it may be reasonable that

we want to ‘cut this down’ by only considering people who have actually expressed an opinion on both propositions $[\varphi]$ and $[\psi]$.

The basic device by which Fitting accomplishes this is a unary cut-down operation:

Definition 6.1.5. *For an element $a \in B$, the Fitting cut-down of a —symbolized by $\llbracket a \rrbracket$ —is defined as $a \oplus \neg a$.*

Definition 6.1.6. *For elements $a, b \in B$, the Kleene-Fitting cut-down connectives Δ and ∇ are defined so that:*

- $a \Delta b =_{df} (a \wedge b) \otimes \llbracket a \rrbracket \otimes \llbracket b \rrbracket$, and
- $a \nabla b =_{df} (a \vee b) \otimes \llbracket a \rrbracket \otimes \llbracket b \rrbracket$

Observation 6.1.1. *For every bilattice \mathcal{B} and all $a \in B$, $\neg \llbracket a \rrbracket = \llbracket \neg a \rrbracket$.*

Proof. It is easily confirmed that \neg distributes over both \otimes and \oplus . Hence, $\neg \llbracket a \rrbracket$, i.e., $\neg(a \oplus \neg a)$ is equivalent to $\neg a \oplus \neg \neg a$. But this is just $\llbracket \neg a \rrbracket$. \square

Observation 6.1.2. *De Morgan’s laws hold for Δ and ∇ , i.e., for all $a, b \in B$, $\neg(a \Delta b) = \neg a \nabla \neg b$ and $\neg(a \nabla b) = \neg a \Delta \neg b$.*

Proof. In the first case, employ Observation 6.1.1 and the fact that De Morgan’s Laws hold with respect to \wedge and \vee to yield the following equivalences:

$$\begin{aligned}
 \neg(a \Delta b) &= \neg((a \wedge b) \otimes \llbracket a \rrbracket \otimes \llbracket b \rrbracket) \\
 &= \neg(a \wedge b) \otimes \neg \llbracket a \rrbracket \otimes \neg \llbracket b \rrbracket \\
 &= (\neg a \vee \neg b) \otimes \llbracket \neg a \rrbracket \otimes \llbracket \neg b \rrbracket \\
 &= \neg a \nabla \neg b
 \end{aligned}$$

The second case follows from identical reasoning. \square

6.2 Cut-Down Operations on Bilattices

In this section, we will review some of Arieli and Avron's work on the logic of bilattices. The techniques and constructions developed by Arieli and Avron are very general and elegant, and can be readily adapted to account for logics including cut-down operations.

6.2.1 Logical Bilattices

In, *e.g.*, (13) and (14), Arieli and Avron have shown that \mathbf{E}_{fde} plays a very robust role with respect to the general theory of bilattices. The salient analogy is that just as classical, two-valued logic acts as the logic of all Boolean algebras, \mathbf{E}_{fde} serves as the logic of all bilattices.

To review the relevant results, consider a few definitions. First, the notion of a *filter* on a partially ordered set is generalized to that of a *bifilter*.

Definition 6.2.1. *A bifilter on a bilattice \mathcal{B} is a nonempty and proper subset $\mathcal{F} \subset B$ such that for all $a, b \in B$,*

- $a \wedge b \in \mathcal{F}$ iff $a \in \mathcal{F}$ and $b \in \mathcal{F}$, and
- $a \otimes b \in \mathcal{F}$ iff $a \in \mathcal{F}$ and $b \in \mathcal{F}$.

A bifilter \mathcal{F} is prime if for all $a, b \in B$,

- if $a \vee b \in \mathcal{F}$ then either $a \in \mathcal{F}$ or $b \in \mathcal{F}$, and
- if $a \oplus b \in \mathcal{F}$ then either $a \in \mathcal{F}$ or $b \in \mathcal{F}$.

In the sequel, bifilters will act as counterparts to familiar sets of truth values. Bifilters permit the recasting of many logical notions in terms of bilattices, *e.g.*, the closure of a bifilter under arbitrary joins can be construed as analogous to the principle of Addition, *i.e.*, that whenever φ is true, the truth of the disjunction $\varphi \dot{\vee} \psi$ for an arbitrary ψ follows.

A non-degenerate bilattice \mathcal{B} (i.e., a bilattice extending $FOUR_2$) equipped with a prime bifilter on B is called by Arieli and Avron a *logical bilattice*:

Definition 6.2.2. *A logical bilattice is a pair $\langle \mathcal{B}, \mathcal{F} \rangle$ where \mathcal{B} is a non-degenerate bilattice and \mathcal{F} is a prime bifilter on B .*

In order to define a consequence relation for a logical bilattice, maps from \mathcal{L} to \mathcal{B} must be defined:

Definition 6.2.3. *An Arieli-Avron valuation on a bilattice \mathcal{B} is a function $v : \mathcal{L} \rightarrow B$ such that:*

- $v(\dot{\neg} \varphi) = \neg(v(\varphi))$
- $v(\varphi \dot{\wedge} \psi) = v(\varphi) \wedge v(\psi)$
- $v(\varphi \dot{\vee} \psi) = v(\varphi) \vee v(\psi)$

Finally, validity for $\langle \mathcal{B}, \mathcal{F} \rangle$ is defined in terms of Arieli-Avron valuations as follows:

Definition 6.2.4. *With respect to a logical bilattice $\langle \mathcal{B}, \mathcal{F} \rangle$, an inference from Γ to φ is AA valid—written $\Gamma \vDash_{\text{AA}}^{\langle \mathcal{B}, \mathcal{F} \rangle} \varphi$ —if for all Arieli-Avron valuations v such that $v[\Gamma] \subseteq \mathcal{F}$, also $v(\varphi) \in \mathcal{F}$.*

In (13), Arieli and Avron prove the remarkable result that for \mathbf{E}_{fde} is sufficient for reasoning about arbitrary bilattices in the following sense:

Observation 6.2.1. *For all logical bilattices $\langle \mathcal{B}, \mathcal{F} \rangle$ and sets of formulae $\Gamma \cup \{\varphi\}$,*

$$\Gamma \vDash_{\text{AA}}^{\langle \mathcal{B}, \mathcal{F} \rangle} \varphi \text{ iff } \Gamma \vDash_{\mathbf{E}_{\text{fde}}} \varphi.$$

Arieli and Avron interpret this result as showing that the relationship between \mathbf{E}_{fde} and bilattices is analogous to that between classical logic and Boolean algebras.

A similar correspondence can now be shown to hold between the logic of cut-down operations on bilattices and the logic \mathbf{S}_{fde} that was described in Definition 2.3.4.

6.2.2 \mathcal{S}_{fde} on Bilattices

To begin, the notion of an Arieli-Avron valuation can be tailored to the case of cut-down operations:

Definition 6.2.5. *A Kleene-Fitting valuation on a bilattice \mathcal{B} is a function $v : \mathcal{L} \rightarrow B$ such that:*

- $v(\dot{\neg} \varphi) = \neg(v(\varphi))$
- $v(\varphi \dot{\wedge} \psi) = v(\varphi) \Delta v(\psi)$
- $v(\varphi \dot{\vee} \psi) = v(\varphi) \nabla v(\psi)$

Validity modulo Kleene-Fitting valuations is identical to validity with respect to Arieli-Avron valuations:

Definition 6.2.6. *With respect to a logical bilattice $\langle \mathcal{B}, \mathcal{F} \rangle$, an inference from Γ to φ is KF valid—written $\Gamma \models_{\text{KF}}^{\langle \mathcal{B}, \mathcal{F} \rangle} \varphi$ —if for all Kleene-Fitting valuations v such that $v[\Gamma] \subseteq \mathcal{F}$, also $v(\varphi) \in \mathcal{F}$.*

One of the most fundamental bilattices is \mathcal{FOUR}_2 , pictured in Figure 6.1. The correspondence between the logic of cut-down operations on \mathcal{FOUR}_2 and \mathcal{S}_{fde} can be established by the following observation.

Observation 6.2.2. *For all sets of formulae Γ and formulae φ ,*

$$\Gamma \models_{\text{KF}}^{\langle \mathcal{FOUR}_2, \{\mathbf{t}, \mathbf{\top}\} \rangle} \varphi \text{ iff } \Gamma \models_{\mathcal{S}_{\text{fde}}} \varphi$$

Proof. Let $h^* : \mathcal{FOUR}_2 \rightarrow \mathcal{V}_{\mathcal{S}_{\text{fde}}}$ be a bijection defined so that:

$$h^*(\mathbf{t}) = \mathbf{t}, h^*(\mathbf{\top}) = \mathbf{b}, h^*(\perp) = \mathbf{u}, \text{ and } h^*(\mathbf{f}) = \mathbf{f}$$

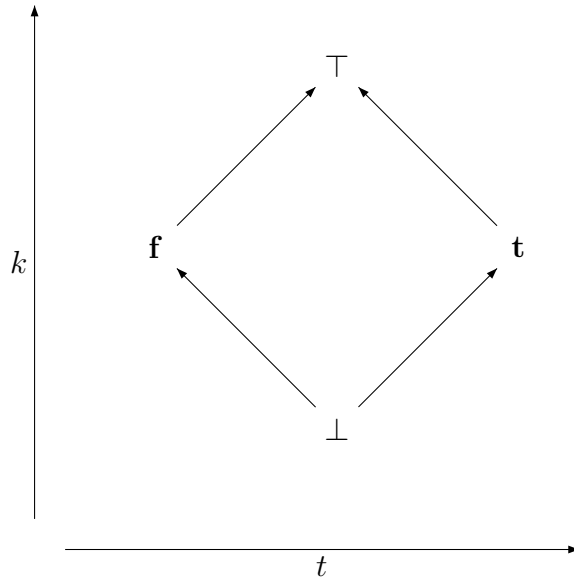

Figure 6.1: The Bilattice $FOUR_2$

Then by examining the operations on $FOUR_2$, one can make their behavior explicit in the form of ‘truth tables’ for the elements of $FOUR_2$:

\neg		Δ	t	\top	\perp	f	∇	t	\top	\perp	f
t	f	t	t	\top	\perp	f	t	t	\perp	t	t
\top	\top	\top	\top	\top	\perp	f	\top	t	\top	\perp	\top
\perp	\perp	\perp	\perp	\perp	\perp	\perp	\perp	\perp	\perp	\perp	\perp
f	t	f	f	f	\perp	f	f	t	\top	\perp	f

By identifying the ‘truth tables’ for $FOUR_2$ with those for S_{fde} , it is simple to confirm that:

- $h^*(\neg a) = f_{S_{fde}}^{\neg} (h^*(a))$
- $h^*(a \Delta b) = f_{S_{fde}}^{\Delta} (h^*(a), h^*(b))$
- $h^*(a \nabla b) = f_{S_{fde}}^{\nabla} (h^*(a), h^*(b))$

Hence, a simple induction on complexity of formulae entails that for every Kleene-Fitting valuation v , there exists an S_{fde} valuation v^* such that for all $\varphi \in \mathcal{L}$, $v^*(\varphi) = h^*(v(\varphi))$. It follows that whenever $\Gamma \not\vdash_{\text{KF}}^{\langle \text{FOUR}_2, \{\mathbf{t}, \top \} \rangle} \varphi$, one can take any Kleene-Fitting valuation v witnessing the failure of the inference to yield an S_{fde} valuation v^* witnessing that $\Gamma \not\vdash_{S_{\text{fde}}} \varphi$.

As h^* is a bijection, one can employ the function $(h^*)^{-1}$ to construct a Kleene-Fitting valuation witnessing the failure of $\Gamma \vdash_{\text{KF}}^{\langle \text{FOUR}_2, \{\mathbf{t}, \top \} \rangle} \varphi$ whenever $\Gamma \not\vdash_{S_{\text{fde}}} \varphi$. \square

Because S_{fde} is a fragment of some of the Kleene logics with guard connectives considered by Fitting in (90), an implicit corollary of Fitting's (90) is that S_{fde} is the logic of cut-down operations on all *bilinear* bilattices as defined in Definition 6.1.4.

Observation 6.2.3. *For all logical bilattices $\langle \mathcal{B}, \mathcal{F} \rangle$ such that \mathcal{B} is bilinear,*

$$\Gamma \vdash_{\text{KF}}^{\langle \mathcal{B}, \mathcal{F} \rangle} \varphi \text{ iff } \Gamma \vdash_{\text{KF}}^{\langle \text{FOUR}_2, \{\top, \mathbf{t}\} \rangle} \varphi.$$

Proof. See (90). \square

This result can be substantially improved, however, to hold not merely for *bilinear* bilattices but for *all* non-degenerate logical bilattices. Thus, S_{fde} emerges as naturally and elegantly from the theory of bilattices as E_{fde} .

In order to show that $\Gamma \vdash_{\text{KF}}^{\langle \mathcal{B}, \mathcal{F} \rangle} \varphi$ holds iff $\Gamma \vdash_{S_{\text{fde}}} \varphi$ for any non-trivial logical bilattice $\langle \mathcal{B}, \mathcal{F} \rangle$ the steps followed by Arieli and Avron in (14) may be adapted without much difficulty. Following this work, recall the below definition:

Definition 6.2.7. *For a logical bilattice $\langle \mathcal{B}, \mathcal{F} \rangle$, define a partition of B by the following:*

- $\mathcal{T}_{\top}^{\langle \mathcal{B}, \mathcal{F} \rangle} = \{a \in B \mid a \in \mathcal{F} \text{ and } \neg a \in \mathcal{F}\}$
- $\mathcal{T}_{\mathbf{t}}^{\langle \mathcal{B}, \mathcal{F} \rangle} = \{a \in B \mid a \in \mathcal{F} \text{ and } \neg a \notin \mathcal{F}\}$
- $\mathcal{T}_{\mathbf{f}}^{\langle \mathcal{B}, \mathcal{F} \rangle} = \{a \in B \mid a \notin \mathcal{F} \text{ and } \neg a \in \mathcal{F}\}$

$$\bullet \mathcal{T}_{\perp}^{(\mathcal{B}, \mathcal{F})} = \{a \in B \mid a \notin \mathcal{F} \text{ and } \neg a \notin \mathcal{F}\}$$

Now, consider some observations concerning cut-down operations on logical bilattices. Let $\langle \mathcal{B}, \mathcal{F} \rangle$ be a logical bilattice where $a, b \in B$.

Observation 6.2.4. $\llbracket a \rrbracket \in \mathcal{F}$ iff either $a \in \mathcal{F}$ or $\neg a \in \mathcal{F}$.

Proof. As $\llbracket a \rrbracket$ is defined as $a \oplus \neg a$, the primeness of \mathcal{F} ensures that $\llbracket a \rrbracket \in \mathcal{F}$ if and only if either $a \in \mathcal{F}$ or $\neg a \in \mathcal{F}$. \square

Observation 6.2.5. $\llbracket a \rrbracket \in \mathcal{T}_{\top}^{(\mathcal{B}, \mathcal{F})}$ iff $a \notin \mathcal{T}_{\perp}^{(\mathcal{B}, \mathcal{F})}$

Observation 6.2.6. $a \triangle b \in \mathcal{F}$ iff $a \in \mathcal{F}$ and $b \in \mathcal{F}$

Proof. For left-to-right, suppose that $a \triangle b \in \mathcal{F}$. Then, as \mathcal{F} is closed upwards under \leq_k and $a \triangle b = (a \wedge b) \otimes \llbracket a \rrbracket \otimes \llbracket b \rrbracket$, also $a \wedge b \in \mathcal{F}$. But as \mathcal{F} is closed upwards under \leq_t and both $a \wedge b \leq_t a$ and $a \wedge b \leq_t b$, it follows that $a \in \mathcal{F}$ and $b \in \mathcal{F}$.

For right-to-left, suppose that $a \in \mathcal{F}$ and $b \in \mathcal{F}$. This entails that $a \wedge b \in \mathcal{F}$ and that both $a, b \notin \mathcal{T}_{\perp}^{(\mathcal{B}, \mathcal{F})}$. By Observation 6.2.5, it follows that $\llbracket a \rrbracket \in \mathcal{F}$ and $\llbracket b \rrbracket \in \mathcal{F}$. As \mathcal{F} is closed upwards under finite meets, these observations entail that $(a \wedge b) \otimes \llbracket a \rrbracket \otimes \llbracket b \rrbracket \in \mathcal{F}$, i.e., $a \triangle b \in \mathcal{F}$. \square

Observation 6.2.7. $a \nabla b \in \mathcal{F}$ iff either $a \in \mathcal{F}$ or $b \in \mathcal{F}$, and both $\llbracket a \rrbracket \in \mathcal{F}$ and $\llbracket b \rrbracket \in \mathcal{F}$.

Proof. For left-to-right, if $a \nabla b \in \mathcal{F}$, then $(a \vee b) \otimes \llbracket a \rrbracket \otimes \llbracket b \rrbracket \in \mathcal{F}$. By closure under \leq_k , it follows that $a \vee b \in \mathcal{F}$ and that both $\llbracket a \rrbracket \in \mathcal{F}$ and $\llbracket b \rrbracket \in \mathcal{F}$. By primeness of \mathcal{F} , $a \vee b \in \mathcal{F}$ entails that either $a \in \mathcal{F}$ or $b \in \mathcal{F}$. Hence, either $a \in \mathcal{F}$ or $b \in \mathcal{F}$ and both $\llbracket a \rrbracket \in \mathcal{F}$ and $\llbracket b \rrbracket \in \mathcal{F}$.

For right-to-left, if $a \in \mathcal{F}$ or $b \in \mathcal{F}$ and both $\llbracket a \rrbracket \in \mathcal{F}$ and $\llbracket b \rrbracket \in \mathcal{F}$, then by closure under finite applications of \otimes , $(a \vee b) \otimes \llbracket a \rrbracket \otimes \llbracket b \rrbracket \in \mathcal{F}$. But this is just to say that $a \nabla b \in \mathcal{F}$. \square

Arieli and Avron's definitions can be further exploited:

Definition 6.2.8. Let $\langle \mathcal{B}_0, \mathcal{F}_0 \rangle$ and $\langle \mathcal{B}_1, \mathcal{F}_1 \rangle$ be logical bilattices and let $a_0 \in B_0$ and $a_1 \in B_1$ be elements of each. Then a_0 and a_1 are similar—written $a_0 \simeq a_1$ —if

- $a_0 \in \mathcal{F}_0$ iff $a_1 \in \mathcal{F}_1$, and
- $\neg a_0 \in \mathcal{F}_0$ iff $\neg a_1 \in \mathcal{F}_1$

Definition 6.2.9. Two Kleene-Fitting valuations v_0 and v_1 for logical bilattices $\langle \mathcal{B}_0, \mathcal{F}_0 \rangle$ and $\langle \mathcal{B}_1, \mathcal{F}_1 \rangle$, respectively, are similar—written $v_0 \simeq v_1$ —if for all atomic $p \in \mathcal{L}$,

$$v_0(p) \simeq v_1(p)$$

Observation 6.2.8. Let v_0 and v_1 be Kleene-Fitting valuations for logical bilattices $\langle \mathcal{B}_0, \mathcal{F}_0 \rangle$ and $\langle \mathcal{B}_1, \mathcal{F}_1 \rangle$, respectively. If $v_0 \simeq v_1$, then for all formulae $\varphi \in \mathcal{L}$,

$$v_0(\varphi) \simeq v_1(\varphi)$$

Proof. By induction on complexity of formulae. For atomic formulae p , this is secured by the assumption that $v_0 \simeq v_1$. For induction hypothesis, assume that whenever ψ is a subformula of φ , $v_0(\psi) \simeq v_1(\psi)$.

Now, in the case of negation, this follows immediately from the involutivity of \neg . If $v_0(\psi) \simeq v_1(\psi)$, then

- $v_0(\dot{\neg} \psi) \in \mathcal{F}_0$ iff $\neg v_0(\psi) \in \mathcal{F}_0$ iff $\neg v_1(\psi) \in \mathcal{F}_1$ iff $v_1(\dot{\neg} \psi) \in \mathcal{F}_1$.
- $v_0(\dot{\neg} \dot{\neg} \psi) \in \mathcal{F}_0$ iff $v_0(\psi) \in \mathcal{F}_0$ iff $v_1(\psi) \in \mathcal{F}_1$ iff $v_1(\dot{\neg} \dot{\neg} \psi) \in \mathcal{F}_1$

But this is just to say that $v_0(\dot{\neg} \psi) \simeq v_1(\dot{\neg} \psi)$.

In the case of a formula $\psi \dot{\wedge} \xi$, by appeal to Observation 6.2.6, infer that $v_0(\psi \dot{\wedge} \xi) \in \mathcal{F}_0$ holds iff both $v_0(\psi) \in \mathcal{F}_0$ and $v_0(\xi) \in \mathcal{F}_0$. By induction hypothesis, this is equivalent to suggesting that both $v_1(\psi) \in \mathcal{F}_1$ and $v_1(\xi) \in \mathcal{F}_1$, which by Observation 6.2.6, is equivalent to $v_1(\psi \dot{\wedge} \xi) \in \mathcal{F}_1$.

In the case of a negated conjunction, by appeal to Observation 6.1.2, $v_0(\dot{\neg}(\psi \dot{\wedge} \xi)) = v_0(\dot{\neg} \psi \dot{\vee} \dot{\neg} \xi)$ —and *mutatis mutandis* for v_1 . Hence, $v_0(\dot{\neg}(\psi \dot{\wedge} \xi)) \in \mathcal{F}_0$ iff $v_0(\dot{\neg} \psi \dot{\vee} \dot{\neg} \xi) \in \mathcal{F}_0$ iff $\neg(v_0(\psi)) \nabla \neg(v_0(\xi)) \in \mathcal{F}_0$. By Observations 6.2.4 and 6.2.7, this is equivalent to the tripartite claim that:

- $\neg(v_0(\psi)) \in \mathcal{F}_0$ or $\neg(v_0(\xi)) \in \mathcal{F}_0$, and
- $\neg(v_0(\psi)) \in \mathcal{F}_0$ or $\neg\neg(v_0(\psi)) \in \mathcal{F}_0$ (i.e., $v_0(\psi) \in \mathcal{F}_0$), and
- $\neg(v_0(\xi)) \in \mathcal{F}_0$ or $\neg\neg(v_0(\xi)) \in \mathcal{F}_0$ (i.e., $v_0(\xi) \in \mathcal{F}_0$)

But by induction hypothesis, this is equivalent to:

- $\neg(v_1(\psi)) \in \mathcal{F}_1$ or $\neg(v_1(\xi)) \in \mathcal{F}_1$, and
- $\neg(v_1(\psi)) \in \mathcal{F}_1$ or $\neg\neg(v_1(\psi)) \in \mathcal{F}_1$, and
- $\neg(v_1(\xi)) \in \mathcal{F}_1$ or $\neg\neg(v_1(\xi)) \in \mathcal{F}_1$.

By further appeal to Observations 6.1.2 and 6.2.7, this is equivalent to suggesting that $v_1(\dot{\neg}(\psi \dot{\wedge} \xi)) \in \mathcal{F}_1$. Hence, both $v_0(\psi \dot{\wedge} \xi) \in \mathcal{F}_0$ iff $v_1(\psi \dot{\wedge} \xi) \in \mathcal{F}_1$ and $\neg v_0(\psi \dot{\wedge} \xi) \in \mathcal{F}_0$ iff $\neg v_1(\psi \dot{\wedge} \xi) \in \mathcal{F}_1$. But this is just to say that $v_0(\psi \dot{\wedge} \xi) \simeq v_1(\psi \dot{\wedge} \xi)$.

The case of disjunction follows analogously.

□

Let ι denote the Russellian definite description operator. Then Arieli and Avron's definitions can be further altered to yield the following:

Definition 6.2.10. Let $g_{\langle \mathcal{B}, \mathcal{F} \rangle} : B \rightarrow FOUR_2$ be a function such that

$$g_{\langle \mathcal{B}, \mathcal{F} \rangle}(x) = \iota y.x \in \mathcal{T}_y^{\langle \mathcal{B}, \mathcal{F} \rangle}$$

This immediately yields the principal lemma:

Lemma 6.2.1. *If v is a Kleene-Fitting valuation on $\langle \mathcal{B}, \mathcal{F} \rangle$, then $g_{\langle \mathcal{B}, \mathcal{F} \rangle} \circ v$ is a valuation on $\langle \mathcal{FOUR}_2, \{\top, \mathbf{t}\} \rangle$ such that $v \simeq g_{\langle \mathcal{B}, \mathcal{F} \rangle} \circ v$.*

Proof. Immediate from the definition of $g_{\langle \mathcal{B}, \mathcal{F} \rangle}$. □

From Lemma 6.2.1, a further observation follows:

Observation 6.2.9. *For all logical bilattices $\langle \mathcal{B}, \mathcal{F} \rangle$,*

$$\Gamma \models_{\text{KF}}^{\langle \mathcal{B}, \mathcal{F} \rangle} \varphi \text{ iff } \Gamma \models_{\text{KF}}^{\langle \mathcal{FOUR}_2, \{\top, \mathbf{t}\} \rangle} \varphi.$$

Proof. For right-to-left, suppose that $\Gamma \models_{\text{KF}}^{\langle \mathcal{B}, \mathcal{F} \rangle} \varphi$. Then there exists a Kleene-Fitting valuation v on $\langle \mathcal{B}, \mathcal{F} \rangle$ such that $v[\Gamma] \subseteq \mathcal{F}$ and $v(\varphi) \notin \mathcal{F}$. Then by Lemma 6.2.1, $g_{\langle \mathcal{B}, \mathcal{F} \rangle} \circ v$ is a Kleene-Fitting valuation on $\langle \mathcal{FOUR}_2, \{\top, \mathbf{t}\} \rangle$ such that $(g_{\langle \mathcal{B}, \mathcal{F} \rangle} \circ v)[\Gamma] \subseteq \{\top, \mathbf{t}\}$ and $(g_{\langle \mathcal{B}, \mathcal{F} \rangle} \circ v)(\varphi) \notin \{\top, \mathbf{t}\}$. This witnesses that $\Gamma \not\models_{\text{KF}}^{\langle \mathcal{FOUR}_2, \{\top, \mathbf{t}\} \rangle} \varphi$.

For left-to-right, let v be a function witnessing that $\Gamma \not\models_{\text{KF}}^{\langle \mathcal{FOUR}_2, \{\top, \mathbf{t}\} \rangle} \varphi$. As $\mathcal{FOUR}_2 \subseteq \mathcal{B}$, v is also a Kleene-Fitting valuation on $\langle \mathcal{B}, \mathcal{F} \rangle$. As $\top, \mathbf{t} \in \mathcal{F}$ and $\perp, \mathbf{f} \notin \mathcal{F}$, it follows that v on $\langle \mathcal{B}, \mathcal{F} \rangle$ is similar to v on $\langle \mathcal{FOUR}_2, \{\top, \mathbf{t}\} \rangle$. Hence v also witnesses that $\Gamma \not\models_{\text{KF}}^{\langle \mathcal{B}, \mathcal{F} \rangle} \varphi$. □

From these observations, one can prove the correspondence of cut-down operations on all bilattices and the logic \mathcal{S}_{fde} .

Observation 6.2.10. *For all logical bilattices $\langle \mathcal{B}, \mathcal{F} \rangle$,*

$$\Gamma \models_{\text{KF}}^{\langle \mathcal{B}, \mathcal{F} \rangle} \varphi \text{ iff } \Gamma \models_{\mathcal{S}_{\text{fde}}} \varphi.$$

Proof. From Observations 6.2.2 and 6.2.9. □

6.3 $\mathcal{NIN}\mathcal{E}_2$ and AC

Now, other unary operations on bilattices appear in the literature that *a priori* conform to Fitting's epistemic understanding of a cut-down. On the bilattice $\mathcal{NIN}\mathcal{E}_2$, shown in Figure

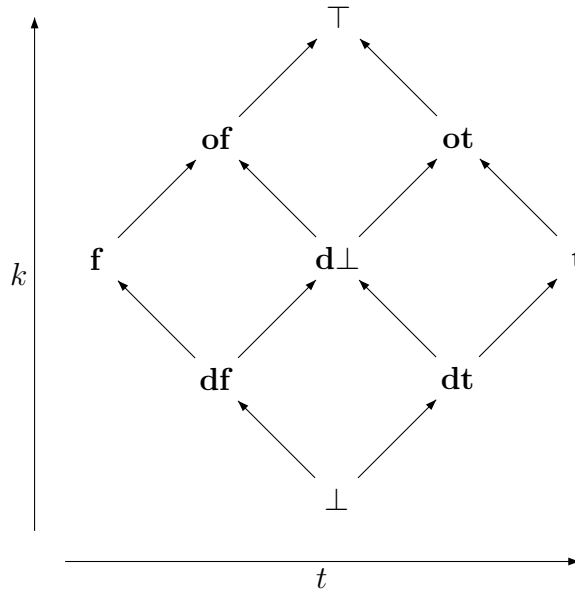

Figure 6.2: The Bilattice \mathcal{NINE}_2

6.2, a further reasonable cut-down corresponds to AC. In (53), Carlos Damásio and Luís Pereira provided a deep study of the bilattice \mathcal{NINE}_2 in the context of logic programming.

Damásio and Pereira equip \mathcal{NINE}_2 with a ‘weak negation’ **not**—a unary negation-like operation lacking involutivity—defined on \mathcal{NINE}_2 by the table:

x	\perp	df	dt	f	t	\top	of	ot	d⊥
$\neg x$	\perp	dt	df	t	f	\top	ot	of	d⊥
not x	\perp	t	f	t	f	\top	\top	\top	\top
not $\neg x$	\perp	f	t	f	t	\top	\top	\top	\top

Now, the unary **not** operation defined by Damásio and Pereira provides the needed tool to define a cut-down similar to the Fitting definition. In (53), the operation $\lambda x.\mathbf{not} \neg x$ is described with a similar epistemic character, as a function that ‘determines if... a proposition is at least believed.’ We will interpret this function as a cut-down.

Definition 6.3.1. For any $a \in B$, $\llbracket a \rrbracket$ —the Damásio-Pereira cut-down of a —is defined as $\neg a$.

Definition 6.3.2. The Damásio-Pereira weak operations \blacktriangle and \blacktriangledown are defined so that:

- $a \blacktriangle b =_{df} (a \wedge b) \otimes \llbracket a \rrbracket \otimes \llbracket b \rrbracket$, and
- $a \blacktriangledown b =_{df} (a \vee b) \otimes \llbracket a \rrbracket \otimes \llbracket b \rrbracket$.

Clearly, interpreting disjunction and conjunction modulo the Damásio-Pereira cut-down is similar in spirit to Fitting’s interpretation of a cut-down. For example, if one evaluates $a \blacktriangledown b$ as true (or a member of \mathcal{F}) only when both $\llbracket a \rrbracket$ and $\llbracket b \rrbracket$ are also members of \mathcal{F} , one is *cutting down* the body of evidence to only those propositions which one at least *believes*.

Definition 6.3.3. A Damásio-Pereira valuation of the language \mathcal{L} on a bilattice \mathcal{B} is a function $v : \mathcal{L} \rightarrow B$ such that:

- $v(\dot{\neg} \varphi) = \neg(v(\varphi))$
- $v(\varphi \dot{\wedge} \psi) = v(\varphi) \blacktriangle v(\psi)$
- $v(\varphi \dot{\vee} \psi) = v(\varphi) \blacktriangledown v(\psi)$

Definition 6.3.4. $\Gamma \models_{\text{DP}}^{(\mathcal{B}, \mathcal{F})} \varphi$ if for every Damásio-Pereira valuation v such that $v(\psi) \in \mathcal{F}$ for each $\psi \in \Gamma$, also $v(\varphi) \in \mathcal{F}$.

Now it may be shown that AC captures the behavior of Damásio-Pereira cut-downs on $\mathcal{NIN}\mathcal{E}_2$.

Observation 6.3.1. $\Gamma \models_{\text{DP}}^{(\mathcal{NIN}\mathcal{E}_2, [\text{t}, \top]_k)} \varphi$ iff $\Gamma \models_{\text{AC}} \varphi$.

Proof. Define two partitions of $\mathcal{NIN}\mathcal{E}_2$: $\Pi^0 = \{\pi_{\text{t}}^0, \pi_{\text{f}}^0, \pi_{\text{u}}^0\}$ and $\Pi^1 = \{\pi_{\text{t}}^1, \pi_{\text{f}}^1, \pi_{\text{u}}^1\}$, defined so that:

- $\pi_t^0 = \{\top, \mathbf{ot}, \mathbf{t}\}$
- $\pi_t^1 = \{\top, \mathbf{of}, \mathbf{f}\}$
- $\pi_f^0 = \{\mathbf{of}, \mathbf{d}\perp, \mathbf{dt}\}$
- $\pi_f^1 = \{\mathbf{ot}, \mathbf{d}\perp, \mathbf{df}\}$
- $\pi_u^0 = \{\mathbf{f}, \mathbf{df}, \perp\}$
- $\pi_u^1 = \{\mathbf{t}, \mathbf{dt}, \perp\}$

Let $\mathbf{v}, \mathbf{v}', \dots$ be arbitrary elements of \mathcal{V}_{Σ_0} ; one can employ a map h such that with respect to each $a \in NINE_2$,

$$h(a) = \langle \imath\mathbf{v}.a \in \pi_{\mathbf{v}}^0, \imath\mathbf{v}'.a \in \pi_{\mathbf{v}'}^1 \rangle$$

h is clearly a bijection between \mathcal{NINE}_2 and \mathcal{V}_{AC} . Moreover, it is also clear that $h[\pi_t^0] = h[[\mathbf{t}, \top]_k] = \mathcal{D}_{AC}$.

What must then be shown is that:

- $h(\neg a) = f_{AC}^{\dot{\neg}}(h(a))$
- $h(a \blacktriangle b) = f_{AC}^{\wedge}(h(a), h(b))$
- $h(a \blacktriangledown b) = f_{AC}^{\vee}(h(a), h(b))$

To begin, note that negation behaves appropriately, that is, if $h(a) = \langle \mathbf{v}, \mathbf{v}' \rangle$ then $h(\neg a) = \langle \mathbf{v}', \mathbf{v} \rangle$, which immediately entails that for all $a \in NINE_2$, $h(\neg a) = f_{AC}^{\dot{\neg}}(h(a))$.

In the case of conjunction, let $a, b \in NINE_2$. One can mimic the behavior of Σ_0 . First consider the element of Π^0 within which $a \blacktriangle b$ lies:

$$\imath\mathbf{v}.a \blacktriangle b \in \pi_{\mathbf{v}}^0 = \begin{cases} \mathbf{t} & \text{if } a \in \pi_t^0 \text{ and } b \in \pi_t^0 \\ \mathbf{u} & \text{if } a \in \pi_u^0 \text{ or } b \in \pi_u^0 \\ \mathbf{f} & \text{otherwise} \end{cases}$$

And compare this to the truth function associated with conjunction in Σ_0 :

$$f_{\Sigma_0}^{\wedge}(\mathbf{v}, \mathbf{v}') = \begin{cases} \mathbf{t} & \text{if } \mathbf{v} = \mathbf{t} \text{ and } \mathbf{v}' = \mathbf{t} \\ \mathbf{u} & \text{if } \mathbf{v} = \mathbf{u} \text{ or } \mathbf{v}' = \mathbf{u} \\ \mathbf{f} & \text{otherwise} \end{cases}$$

It immediately follows that

$$\mathbf{v}.a \blacktriangle b \in \pi_{\mathbf{v}}^0 = f_{\Sigma_0}^{\wedge}(\mathbf{v}'.a \in \pi_{\mathbf{v}'}^0, \mathbf{v}'' .b \in \pi_{\mathbf{v}''}^0)$$

Let pr_0 and pr_1 be the projection operators onto the first and second coordinates. From the above reasoning conjoined with the relationship between Σ_0 and AC , one can infer that:

$$\mathbf{v}.a \blacktriangle b \in \pi_{\mathbf{v}}^0 = \text{pr}_0(f_{\text{AC}}^{\wedge}(\langle \mathbf{v}'.a \in \pi_{\mathbf{v}'}^0, \mathbf{w} \rangle, \langle \mathbf{v}'' .b \in \pi_{\mathbf{v}''}^0, \mathbf{w}' \rangle))$$

where \mathbf{w} and \mathbf{w}' are arbitrary elements of \mathcal{V}_{Σ_0} . A similar correspondence for the second coordinate entails that

$$\mathbf{v}.a \blacktriangle b \in \pi_{\mathbf{v}}^1 = \text{pr}_1(f_{\text{AC}}^{\vee}(\langle \mathbf{w}, \mathbf{v}'.a \in \pi_{\mathbf{v}'}^1 \rangle, \langle \mathbf{w}', \mathbf{v}'' .b \in \pi_{\mathbf{v}''}^1 \rangle))$$

for arbitrary $\mathbf{w}, \mathbf{w}' \in \mathcal{V}_{\Sigma_0}$. Putting these observations together, one can infer that:

$$h(a \blacktriangle b) = f_{\text{AC}}^{\wedge}(h(a), h(b))$$

That the analogous equivalence holds for disjunction follows from the duality of conjunction and disjunction.

Hence, an induction on complexity of formulae entails that for any Damásio-Pereira valuation v witnessing that $\Gamma \not\vdash_{\text{DP}}^{\langle \mathcal{NIN}\mathcal{E}_2, [\mathbf{t}, \top]_k \rangle} \varphi$, one can find a corresponding AC valuation $h \circ v$ witnessing the failure of $\Gamma \vDash_{\text{AC}} \varphi$. That h is a bijection entails that this holds from right-to-left as well. Hence, $\Gamma \vDash_{\text{DP}}^{\langle \mathcal{NIN}\mathcal{E}_2, [\mathbf{t}, \top]_k \rangle} \varphi$ holds iff $\Gamma \vDash_{\text{AC}} \varphi$. \square

Now, recent work on related structures—*trilattices*—have suggested that the Belnap-Dunn logic \mathbf{E}_{fde} is as firmly entrenched in the theory of multilattices in general. For example, the logic induced many of the interpretations of connectives on the trilattice described in

(174) ends up equivalent for all intents and purposes with E_{fde} . Given the foregoing, it is natural to ask whether S_{fde} and related systems emerge in the theory of multilattices as well.

We will proceed to show that the logic of cut-downs on trilattices is sensitive to how one interprets logical negation and that the two most natural interpretations of negation lead to S_{fde} and AC.

6.4 Cut-Down Operations on Trilattices

Trilattices are a natural generalization of bilattices introduced in (174), in which they were offered as a generalization of bilattices in which orderings \leq_t and \leq_k were joined by an ordering \leq_c measuring the *constructivity* of a degree of truth. More recent discussions of trilattices (e.g., (163), (174), (175)) forgo the use of a constructivity ordering in favor of a *falsity* ordering \leq_f distinct from \leq_t . We will follow this convention, although it is important to note that nothing essentially hinges on the interpretation of the ordering \leq_f .

Definition 6.4.1. *A trilattice \mathcal{T} is a structure $\langle T, \leq_t, \leq_f, \leq_k \rangle$ where:*

- *T is a nonempty set*
- *\leq_t, \leq_f , and \leq_k are partial orderings of T such that $\langle T, \leq_t, \leq_k \rangle$, $\langle T, \leq_t, \leq_f \rangle$, and $\langle T, \leq_f, \leq_k \rangle$ are complete prebilattices*

Each partial ordering induces binary meet and join operators. We will employ the convention of treating \leq_t and \leq_f as *alethic*, and thus describe the corresponding meets and joins as \wedge_t , \vee_t , \wedge_f , and \vee_f . We treat \leq_k as an information ordering and carry over the notation of \otimes_k and \oplus_k to reinforce this interpretation.

In (174), Shramko, Dunn, and Takenaka explicitly part ways with the convention of including a negation-like operation in the definition of a bilattice, and omit the requirement

that such an inversion exists from the definition of a trilattice. However, we are interested in such negation-like operators and we may define inversions as follows:

Definition 6.4.2. *A t -inversion on a trilattice \mathcal{T} is an involutive function $\neg_t : T \rightarrow T$ such that for all $a, b \in T$:*

- *If $a \leq_t b$ then $\neg_t b \leq_t \neg_t a$*
- *If $a \leq_f b$ then $\neg_t a \leq_f \neg_t b$*
- *If $a \leq_k b$ then $\neg_t a \leq_k \neg_t b$*

f -inversions \neg_f and tf -inversions \neg_{tf} are defined analogously, i.e., \neg_f reverses the ordering \leq_f but respects \leq_t and \leq_k , while \neg_{tf} reverses both \leq_t and \leq_f but respects \leq_k .

Much of the formal work in the sequel will appeal to Umberto Rivieccio's representation theorems found in (163) that show that many classes of trilattices are isomorphic to certain products of bilattices. By appealing to these representation theorems, we will be able to export some of the properties of cut-down operations on bilattices to the case of trilattices without difficulty.

A product trilattice of two bilattices—the generalization of the Ginsberg-Fitting product of two lattices—is defined as follows:

Definition 6.4.3. *For bilattices $\mathcal{A} = \langle A, \leq_t^A, \leq_k^A, \neg^A \rangle$ and $\mathcal{B} = \langle B, \leq_t^B, \leq_k^B, \neg^B \rangle$, the product trilattice $\mathcal{A} \odot \mathcal{B}$ is the trilattice $\langle A \times B, \leq_t, \leq_f, \leq_i \rangle$ where for all $\langle a, b \rangle, \langle a', b' \rangle \in A \times B$:*

- *$\langle a, b \rangle \leq_t \langle a', b' \rangle$ if $a \leq_t^A a'$ and $b \leq_t^B b'$*
- *$\langle a, b \rangle \leq_f \langle a', b' \rangle$ if $a' \leq_k^A a$ and $b \leq_k^B b'$*
- *$\langle a, b \rangle \leq_k \langle a', b' \rangle$ if $a \leq_k^A a'$ and $b \leq_k^B b'$*

From this definition, we can explicitly represent the meets and joins on $\mathcal{A} \odot \mathcal{B}$ by the following:

$$\begin{aligned} \langle a, b \rangle \wedge_t \langle a', b' \rangle &= \langle a \wedge^{\mathcal{A}} a', b \wedge^{\mathcal{B}} b' \rangle & \langle a, b \rangle \vee_t \langle a', b' \rangle &= \langle a \vee^{\mathcal{A}} a', b \vee^{\mathcal{B}} b' \rangle \\ \langle a, b \rangle \wedge_f \langle a', b' \rangle &= \langle a \oplus^{\mathcal{A}} a', b \otimes^{\mathcal{B}} b' \rangle & \langle a, b \rangle \vee_f \langle a', b' \rangle &= \langle a \otimes^{\mathcal{A}} a', b \oplus^{\mathcal{B}} b' \rangle \\ \langle a, b \rangle \otimes_k \langle a', b' \rangle &= \langle a \otimes^{\mathcal{A}} a', b \otimes^{\mathcal{B}} b' \rangle & \langle a, b \rangle \oplus_k \langle a', b' \rangle &= \langle a \oplus^{\mathcal{A}} a', b \oplus^{\mathcal{B}} b' \rangle \end{aligned}$$

Inversions behave nicely on product trilattices, so that \neg_t and \neg_f are unique:

Definition 6.4.4. *On a product trilattice $\mathcal{A} \odot \mathcal{B}$, if \mathcal{A} and \mathcal{B} have negations $\neg^{\mathcal{A}}$ and $\neg^{\mathcal{B}}$, respectively, then the t -inversion \neg_t is defined so that for all $\langle a, b \rangle \in \mathcal{A} \times \mathcal{B}$:*

- $\neg_t \langle a, b \rangle =_{df} \langle \neg^{\mathcal{A}} a, \neg^{\mathcal{B}} b \rangle$

If, moreover there is an isomorphism $h : \mathcal{A} \cong \mathcal{B}$, then the f -inversion \neg_f is defined so that:

- $\neg_f \langle a, b \rangle = \langle h^{-1}(b), h(a) \rangle$

Product trilattices will be useful due to Umberto Rivieccio's representation theorems for a large class of trilattices presented in (163). Rivieccio shows that every *interlaced* trilattice \mathcal{T} is isomorphic to a product trilattice. The property of interlacing—which appears in many contexts in the theory of bilattices as well—is a very natural property, being exhibited by the most common bilattices and trilattices (e.g., \mathcal{FOUR}_2 , \mathcal{NINE}_2 , $\mathcal{SIXTEEN}_3$ are all interlaced).

Definition 6.4.5. *A trilattice \mathcal{T} is interlaced if the binary operations $\wedge_t, \vee_t, \wedge_f, \vee_f, \otimes_k$, and \oplus_k are each monotone with respect to all three orderings.*

For our purposes, the most important representation theorems of (163) are those involving interlaced trilattices with inversions that naturally correspond to negation:

Theorem 6.4.1 (Rivieccio). *\mathcal{T} is an interlaced trilattice if and only if \mathcal{T} is isomorphic to a product trilattice $\mathcal{A} \odot \mathcal{B}$ where \mathcal{A} and \mathcal{B} are prebilattices.*

Theorem 6.4.2 (Rivieccio). \mathcal{T} is an interlaced trilattice with t - and f -inversions if and only if \mathcal{T} is isomorphic to a product trilattice $\mathcal{A} \odot \mathcal{A}$ where \mathcal{A} is a prebilattice.

It follows from the observations of (163) that on an interlaced trilattice with inversions \neg_t and \neg_f , \neg_t and \neg_f always commute.

By Theorem 6.4.2, there is essentially a single t -inversion on an interlaced trilattice, which permits us to state the following corollary concerning tf -inversions:

Corollary 6.4.1. For an interlaced trilattice \mathcal{T} with t - and f -inversions, there exists precisely one tf -inversion \neg_{tf} , equivalent to the operation $\neg_t \neg_f$.

Proof. A tf -inversion \neg_{tf} is identical to the operation $\neg_{tf} \neg_f \neg_f$ and Definition 6.4.4 entails that $\neg_{tf} \neg_f$ is just the unique t -inversion. Hence, for any $a \in T$, $\neg_{tf} a = \neg_{tf} \neg_f \neg_f a = \neg_t \neg_f a$. \square

In the sequel, this entitles us to treat an inversion \neg_{tf} as interchangeable with the decomposed $\neg_t \neg_f$ (or, equivalently, $\neg_f \neg_t$).

6.4.1 Generalizations of Cut-Down Operations

In the case of trilattices, the plenitude of distinct ways to define negation-like inversions and conjunction and disjunction-like meets and joins entails that the Kleene-Fitting cut-down does not pick out a unique generalization. For example, if a cut-down is defined as the information join of an element and its negation, the natural question arises: By which inversion should we interpret negation? If there are meets and joins modulo both the truth and falsity orderings, in terms of which ordering should we define, say, weak conjunction?

When a trilattice has a k -inversion \neg_k , the value $x \oplus \neg_k x$ will map all elements x to the information-top, so defining a cut-down $\llbracket x \rrbracket_k$ by the scheme $\llbracket x \rrbracket_k = (x \oplus \neg_k x)$ will be fruitless.

In the sequel, we will consider cut-down conjunctions and disjunctions to be interpreted in virtue of the ordering \leq_t . Generally speaking, inference as truth-preservation is a more

familiar concept than other candidates, and on this interpretation, \wedge_t and \vee_t are most noticeably recognizable as the standard conjunction and disjunction connectives. We'll first define our cut-down operations:

Definition 6.4.6. *For an element a of a trilattice \mathcal{T} with a t -inversion, the t -cut-down of a — $\llbracket a \rrbracket_t$ —is defined so that:*

- $\llbracket a \rrbracket_t =_{df} a \oplus_k \neg_t a$

Definition 6.4.7. *For a trilattice with a t -inversion, the t -weak conjunction Δ_t and the t -weak disjunction ∇_t are defined:*

- $x \Delta_t y =_{df} (x \wedge_t y) \otimes_k \llbracket x \rrbracket_t \otimes_k \llbracket y \rrbracket_t$

- $x \nabla_t y =_{df} (x \vee_t y) \otimes_k \llbracket x \rrbracket_t \otimes_k \llbracket y \rrbracket_t$

For the interpretation of negation, we will consider the options of interpreting the t -inversion \neg_t and the tf -inversion \neg_{tf} (i.e., $\neg_t \neg_f$). These—along with \neg_f —are cited by Shramko and Wansing as ‘the most obvious candidates for representing an object-language negation.’ (175, p. 133) Both appear to be equally natural in this context; e.g., both inversions \neg_t and \neg_{tf} interact with the cut-down $\llbracket a \rrbracket_t$ in a similar fashion to what was observed in the case of bilattices:

Observation 6.4.1. *For a trilattice \mathcal{T} with a inversion \neg_t , for all $a \in T$,*

$$\neg_t \llbracket a \rrbracket_t = \llbracket \neg_t a \rrbracket_t$$

Proof. $\neg_t \llbracket a \rrbracket_t = \neg_t(a \oplus_k \neg_t a)$. Because \neg_t distributes over the information join \oplus_k , this is equivalent to $\neg_t a \oplus_k \neg_t \neg_t a$, i.e., $\llbracket \neg_t a \rrbracket_t$. □

Observation 6.4.2. *For a trilattice \mathcal{T} with commuting inversions \neg_t and \neg_f , for all $a \in T$,*

$$\neg_{tf} \llbracket a \rrbracket_t = \llbracket \neg_{tf} a \rrbracket_t$$

Proof. We appeal to the following equivalences: $\neg_{tf} \llbracket a \rrbracket_t$ is equivalent by definition to $\neg_{tf}(a \oplus \neg_t a)$ and hence, to $\neg_{tf} a \oplus \neg_{tf} \neg_t a$. Because $\neg_{tf} \neg_t a = \neg_t \neg_f \neg_t a$, by commutativity of \neg_t and \neg_f , we infer that this is equivalent to $\neg_{tf} a \oplus \neg_t \neg_{tf} a$, which is just $\llbracket \neg_{tf} a \rrbracket_t$. \square

Moreover, De Morgan's laws can be seen to hold for both species of inversion.

Observation 6.4.3. *For all elements a and b in a trilattice \mathcal{T} with an inversion \neg_t , $\neg_t(a \Delta_t b) = \neg_t a \nabla_t \neg_t b$ and $\neg_t(a \nabla_t b) = \neg_t a \Delta_t \neg_t b$*

Proof. $\neg_t(a \Delta_t b)$ is just $\neg_t((a \wedge_t b) \otimes_k \llbracket a \rrbracket_t \otimes_k \llbracket b \rrbracket_t)$. \neg_t distributes over \otimes_k , whence we infer equivalence with $\neg_t(a \wedge_t b) \otimes_k \neg_t \llbracket a \rrbracket_t \otimes_k \neg_t \llbracket b \rrbracket_t$. By Observation 6.4.1 and De Morgan's laws for \wedge_t , we infer equivalence with $(\neg_t a \vee_t \neg_t b) \otimes_k \llbracket \neg_t a \rrbracket_t \otimes_k \llbracket \neg_t b \rrbracket_t$, *i.e.*, $\neg_t a \nabla_t \neg_t b$.

The second case follows from analogous reasoning. \square

Observation 6.4.4. *For all elements a and b in a trilattice, $\neg_{tf}(a \Delta_t b) = \neg_{tf} a \nabla_t \neg_{tf} b$ and $\neg_{tf}(a \nabla_t b) = \neg_{tf} a \Delta_t \neg_{tf} b$*

Proof. $\neg_{tf}(a \Delta_t b) = \neg_{tf}((a \wedge_t b) \otimes_k \llbracket a \rrbracket_t \otimes_k \llbracket b \rrbracket_t)$. Because both \neg_t and \neg_f distribute over \otimes_k , this is equal to $\neg_{tf}(a \wedge_t b) \otimes_k \neg_{tf} \llbracket a \rrbracket_t \otimes_k \neg_{tf} \llbracket b \rrbracket_t$. We can note that $\neg_{tf}(a \wedge_t b) = \neg_{tf} a \vee_t \neg_{tf} b$. $\neg_{tf}(a \wedge_t b)$ is defined as $\neg_t \neg_f(a \wedge_t b)$. The f -inversion distributes over the t -operations, so this is equal to $\neg_t(\neg_f a \wedge_t \neg_f b)$, which—by De Morgan's laws—is equivalent to $\neg_t \neg_f a \vee_t \neg_t \neg_f b$, *i.e.*, $\neg_{tf} a \vee_t \neg_{tf} b$. Furthermore, by Lemma 6.4.2, $\neg_{tf} \llbracket a \rrbracket_t \otimes_k \neg_{tf} \llbracket b \rrbracket_t$ is equal to $\llbracket \neg_{tf} a \rrbracket_t \otimes_k \llbracket \neg_{tf} b \rrbracket_t$.

Putting these observations together, we infer that $\neg_{tf}(a \wedge_t b) \otimes_k \neg_{tf} \llbracket a \rrbracket_t \otimes_k \neg_{tf} \llbracket b \rrbracket_t$ is equivalent to $(\neg_{tf} a \vee_t \neg_{tf} b) \otimes_k \llbracket \neg_{tf} a \rrbracket_t \otimes_k \llbracket \neg_{tf} b \rrbracket_t$, *i.e.*, $\neg_{tf} a \nabla_t \neg_{tf} b$. The second case follows by dualizing the foregoing argument. \square

With natural generalizations of cut-down operations in hand, we now proceed to consider how to consider *logical consequence* in this setting, again by generalization Arieli and Avron's approach.

6.4.2 Some Properties of Trifilters

Now, because we wish to talk about *validity* with respect to certain operations on trilattices, we proceed generalize Arieli and Avron's notion of a bifilter to the case of a trilattice. We will call the following natural generalization a *trifilter*, that is, a set of the elements of a trilattice that is closed upwards under each of the three orderings.

Definition 6.4.8. *A trifilter on a trilattice \mathcal{T} is a nonempty and proper subset $\mathcal{F} \subset T$ closed upwards under each ordering and closed under finite meets:*

$$a \wedge_t b \in \mathcal{F} \text{ iff } a \wedge_f b \in \mathcal{F} \text{ iff } a \otimes_k b \in \mathcal{F} \text{ iff } a \in \mathcal{F} \text{ and } b \in \mathcal{F}.$$

\mathcal{F} is prime if for all $a, b \in B$,

$$a \vee_t b \in \mathcal{F} \text{ iff } a \vee_f b \in \mathcal{F} \text{ iff } a \oplus_k b \in \mathcal{F} \text{ iff either } a \in \mathcal{F} \text{ or } b \in \mathcal{F}.$$

By this definition, a trifilter is a special case of the notion of a *multifilter* independently defined by Yaroslav Shramko in (173).

It will behoove us to establish a few connections between trifilters on product trilattices and bifilters on the bilattices from which they are constructed. Given the representation theorems for interlaced trilattices, these results will enable us to apply many observations about bifilters to the case of trifilters.

In the first case, we can show that given a product trilattice $\mathcal{A} \odot \mathcal{B}$, the product of A (i.e., the elements of bilattice \mathcal{A}) and any prime filter on \mathcal{B} will yield a trifilter on the product trilattice.

Lemma 6.4.1. *For a product trilattice $\mathcal{A} \odot \mathcal{B}$ and a prime bifilter $\mathcal{F}_{\mathcal{B}}$ on \mathcal{B} , the set $\mathcal{F} = A \times \mathcal{F}_{\mathcal{B}}$ is a prime trifilter on $\mathcal{A} \odot \mathcal{B}$.*

Proof. Let $\mathcal{A} = \langle A, \leq_t^A, \leq_k^A \rangle$ and $\mathcal{B} = \langle B, \leq_t^B, \leq_k^B \rangle$ be the prebilattices that yield $\mathcal{A} \odot \mathcal{B}$ and fix an element $\langle a, b \rangle \in \mathcal{F}$.

Then if $\langle a, b \rangle \leq_t \langle a', b' \rangle$, that $a' \in A$ follows by definition. By the primeness of $\mathcal{F}_{\mathcal{B}}$, we also know that $b \leq_t^{\mathcal{B}} b'$ entails that $b' \in \mathcal{F}_{\mathcal{B}}$. If $\langle a, b \rangle \leq_f \langle a', b' \rangle$ or $\langle a, b \rangle \leq_k \langle a', b' \rangle$, then $a' \in A$ by construction and because $b \leq_k^{\mathcal{B}} b'$, also $b' \in \mathcal{F}_{\mathcal{B}}$. In all three cases, $\langle a', b' \rangle \in \mathcal{F}$.

For primeness, suppose $\langle a, b \rangle \vee_t \langle a', b' \rangle \in \mathcal{F}$. This element is $\langle a \vee^A a', b \vee^{\mathcal{B}} b' \rangle$, whence $b \vee^{\mathcal{B}} b' \in \mathcal{F}_{\mathcal{B}}$. By primeness of $\mathcal{F}_{\mathcal{B}}$, either $b \in \mathcal{F}_{\mathcal{B}}$ or $b' \in \mathcal{F}_{\mathcal{B}}$. Because both a and a' are elements of A , the first case entails that $\langle a, b \rangle \in \mathcal{F}$ and the second entails that $\langle a', b' \rangle \in \mathcal{F}$. The cases of primeness for the falsity and information orderings follow from a similar argument. □

Conversely, we can show that *every* trifilter on a product trilattice can be represented as such a product.

Lemma 6.4.2. *Every prime trifilter on a product trilattice $\mathcal{A} \odot \mathcal{B}$ is identical to a product $A \times \mathcal{F}_{\mathcal{B}}$ where $\mathcal{F}_{\mathcal{B}}$ is a prime bifilter on \mathcal{B} .*

Proof. Let \mathcal{F} be a prime trifilter on $\mathcal{A} \odot \mathcal{B}$.

We consider the first coordinate. Consider an arbitrary element $a \in A$ and pick an arbitrary $\langle a', b' \rangle \in \mathcal{F}$. Then $a' \leq_k^A (a \oplus^A a')$ and $b' \leq_t^{\mathcal{B}} b'$, so $\langle a', b' \rangle \leq_k \langle a \oplus^A a', b' \rangle$, whence by closure under \leq_k , $\langle (a \oplus^A a'), b' \rangle \in \mathcal{F}$. However, because $a \leq^A (a \oplus^A a')$ and $b' \leq_k^A b'$, also $\langle (a \oplus^A a'), b' \rangle \leq_f \langle a, b' \rangle$. By closure under \leq_f , this entails that $\langle a, b' \rangle \in \mathcal{F}$. It follows that whenever $\langle a', b' \rangle \in \mathcal{F}$, for *all* $a \in A$, also $\langle a, b' \rangle \in \mathcal{F}$. Hence, \mathcal{F} is the product of A and the set

$$\mathcal{F}_{\mathcal{B}} = \{b \in \mathcal{B} \mid \exists a \in A \text{ such that } \langle a, b \rangle \in \mathcal{F}\}$$

We now must show that $\mathcal{F}_{\mathcal{B}}$ is a prime bifilter on \mathcal{B} . For any $b \in \mathcal{F}_{\mathcal{B}}$, there is an $a \in A$ such that $\langle a, b \rangle \in \mathcal{F}$. Hence, whenever $b \leq_t^{\mathcal{B}} b'$ or $b \leq_k^{\mathcal{B}} b''$, $\langle a, b \rangle \leq_t \langle a, b' \rangle$ and $\langle a, b \rangle \leq_k \langle a, b' \rangle$, respectively. In the first case, closure of the trifilter \mathcal{F} entails that $\langle a, b' \rangle \in \mathcal{F}$, whence

$b' \in \mathcal{F}_B$; in the second case, closure entails that $\langle a, b'' \rangle \in \mathcal{F}$, ensuring that $b'' \in \mathcal{F}_R$. Thus, \mathcal{F}_R is a bifilter on \mathcal{B} .

For primeness of \mathcal{F}_B , if $b \vee^B b' \in \mathcal{F}_R$, then for some $a \in A$, $\langle a, b \vee^B b' \rangle \in \mathcal{F}$. But this element is $\langle (a \vee^A a), (b \vee^B b') \rangle$, *i.e.*, $\langle a, b \rangle \vee_t \langle a, b' \rangle$, and by primeness of \mathcal{F} , either $\langle a, b \rangle \in \mathcal{F}$ (entailing that $b \in \mathcal{F}_B$) or $\langle a, b' \rangle \in \mathcal{F}$ (entailing that $b' \in \mathcal{F}_B$). An identical argument yields primeness of \mathcal{F}_B with respect to \oplus^B as well. \square

6.5 Analytic Logic on Trilattices

With the foregoing definitions, the approach to bilattice logic championed by Arieli and Avron—and the variations upon this approach described in Section 6.2.2—are readily adapted to the case of interlaced trilattices.

Definition 6.5.1. *A logical trilattice is a pair $\langle \mathcal{T}, \mathcal{F} \rangle$ where \mathcal{T} is a non-degenerate trilattice and \mathcal{F} is a prime trifilter on \mathcal{T} .*

Note the reappearance of the condition that \mathcal{T} must be *non-degenerate*. This is essentially the condition that the theory of the trilattice is sufficiently rich. The smallest non-degenerate trilattice is $SL\mathcal{X}\mathcal{T}\mathcal{E}\mathcal{E}\mathcal{N}_3$. This is a very reasonable constraint, *e.g.*, it is required in the case of logical bilattices described in Definition 6.2.2.

As stated before, we have two inversions that equally resemble negation. We will thus define two types of valuations: one in which negation $\dot{\neg}$ is interpreted as \neg_t and another in which negation is considered to be \neg_{tf} . The upshot will be that the former logic of cut-downs on trilattices is S_{fde} while the latter logic is equivalent to AC. The general structure of the two arguments will be to first show a correspondence between any logical trilattice in which the trilattice is a product and the logical trilattice $\langle \mathcal{F}OUR_2 \odot \mathcal{F}OUR_2, \mathcal{F}OUR_2 \times \{\top, \mathbf{t}\} \rangle$, then to show a correspondence between valuations of an appropriate type on $\langle \mathcal{F}OUR_2 \odot$

$\mathcal{FOUR}_2, \mathcal{FOUR}_2 \times \{\top, \mathbf{t}\}$ and consequence in \mathbf{S}_{fde} or \mathbf{AC} . Finally, we will appeal to Rivieccio's representation theorems to prove that the correspondence extends to all logical bilattices $\langle \mathcal{T}, \mathcal{F} \rangle$ such that \mathcal{T} is interlaced.

6.5.1 \mathbf{S}_{fde} on Trilattices

First, we will examine the logic of cut-down operations on trilattices in which negation is interpreted as a t -inversion. The most natural generalization of Kleene-Fitting valuations may be defined as follows:

Definition 6.5.2. *A \neg_t -Kleene-Fitting valuation on a trilattice \mathcal{T} is a function $v : \mathcal{L} \rightarrow T$ such that:*

- $v(\dot{\neg} \varphi) = \neg_t(v(\varphi))$
- $v(\varphi \dot{\wedge} \psi) = v(\varphi) \Delta_t v(\psi)$
- $v(\varphi \dot{\vee} \psi) = v(\varphi) \nabla_t v(\psi)$

Definition 6.5.3. *An inference from Γ to φ is \neg_t -KF valid on a logical trilattice $\langle \mathcal{T}, \mathcal{F} \rangle$ —written $\Gamma \vDash_{\text{KF}[\neg_t]}^{\langle \mathcal{T}, \mathcal{F} \rangle} \varphi$ —if for all \neg_t -Kleene-Fitting valuations v , if $v[\Gamma] \subseteq \mathcal{F}$ then $v(\varphi) \in \mathcal{F}$.*

Given the representation theorems for interlaced trilattices, we will consider only product trilattices for the moment.

Let us define a second notion of similarity, tailored to the case in which negation is identified with the operation of t -inversion.

Definition 6.5.4. *Consider two logical product trilattices $\langle \mathcal{A}_0 \odot \mathcal{B}_0, \mathcal{A}_0 \times \mathcal{F}_0 \rangle$ and $\langle \mathcal{A}_1 \odot \mathcal{B}_1, \mathcal{A}_1 \times \mathcal{F}_1 \rangle$ where \mathcal{F}_0 and \mathcal{F}_1 are prime bifilters on \mathcal{B}_0 and \mathcal{B}_1 , respectively. Then two elements $\langle a, b \rangle \in \mathcal{A}_0 \times \mathcal{B}_0$ and $\langle a', b' \rangle \in \mathcal{A}_1 \times \mathcal{B}_1$ are \neg_t -similar—written $\langle a, b \rangle \simeq_t \langle a', b' \rangle$ —if:*

- $\langle a, b \rangle \in \mathcal{A}_0 \times \mathcal{F}_0$ if and only if $\langle a', b' \rangle \in \mathcal{A}_1 \times \mathcal{F}_1$, and

- $\neg_t(\langle a, b \rangle) \in A_0 \times \mathcal{F}_0$ if and only if $\neg_t(\langle a', b' \rangle) \in A_1 \times \mathcal{F}_1$

As in the case of Section 6.2.2, the notion of \neg_t -similarity between two points extends to \neg_t -Kleene-Fitting valuations as well.

Definition 6.5.5. *Two \neg_t -Kleene-Fitting valuations v_0 and v_1 on logical trilattices $\langle \mathcal{A}_0 \odot \mathcal{B}_0, A_0 \times \mathcal{F}_0 \rangle$ and $\langle \mathcal{A}_1 \odot \mathcal{B}_1, A_1 \times \mathcal{F}_1 \rangle$ are \neg_t -similar if for all atomic $p \in \mathcal{L}$, $v_0(p) \simeq_t v_1(p)$.*

This definition allows us to prove two intermediate lemmas suggesting that many properties of a logical trilattice $\langle \mathcal{A} \odot \mathcal{B}, A \times \mathcal{F}_{\mathcal{B}} \rangle$ can be recovered from the logical bilattice $\langle \mathcal{B}, \mathcal{F}_{\mathcal{B}} \rangle$.

Lemma 6.5.1. *Consider a logical trilattice $\langle \mathcal{A} \odot \mathcal{B}, A \times \mathcal{F}_{\mathcal{B}} \rangle$, with $\mathcal{F}_{\mathcal{B}}$ a prime bifilter on \mathcal{B} . Then for every \neg_t -Kleene-Fitting valuation v :*

$$v(\varphi) \in \mathcal{F} \text{ if and only if } \text{pr}_1(v(\varphi)) \in \mathcal{F}_{\mathcal{B}}$$

Proof. Immediate from Lemma 6.4.2. □

Lemma 6.5.2. *Let v be a \neg_t -Kleene-Fitting valuation on a logical trilattice $\langle \mathcal{A} \odot \mathcal{B}, A \times \mathcal{F}_{\mathcal{B}} \rangle$ with $\mathcal{F}_{\mathcal{B}}$ a prime bifilter on \mathcal{B} . Then $\text{pr}_1 \circ v$ is a Kleene-Fitting valuation on the logical bilattice $\langle \mathcal{B}, \mathcal{F}_{\mathcal{B}} \rangle$.*

Proof. We prove that $\text{pr}_1 \circ v$ is in fact a Kleene-Fitting valuation on $\langle \mathcal{B}, \mathcal{F}_{\mathcal{B}} \rangle$ by induction on complexity of formulae. As a basis step, we note that $\text{pr}_1 \circ v$ maps atoms to elements of \mathcal{B} , as required.

In the case of a formula $\dot{\neg} \psi$, let $v(\psi) = \langle a, b \rangle$. Then:

$$\text{pr}_1(\neg_t \langle a, b \rangle) = \text{pr}_1(\langle \neg_{\mathcal{A}} a, \neg_{\mathcal{B}} b \rangle) = \neg_{\mathcal{B}}(\text{pr}_1(\langle a, b \rangle))$$

In other words, $(\text{pr}_1 \circ v)(\dot{\neg} \psi) = \neg_{\mathcal{B}}((\text{pr}_1 \circ v)(\psi))$.

In the case of conjunction, let $\langle a, b \rangle$ and $\langle a', b' \rangle$ be the values of $v(\psi)$ and $v(\xi)$, respectively. Then $v(\psi \dot{\wedge} \xi) = \langle a, b \rangle \Delta_t \langle a', b' \rangle$, whence:

$$\text{pr}_1(\langle a, b \rangle \Delta_t \langle a', b' \rangle) = \text{pr}_1(\langle a \Delta^A a', b \Delta^B b' \rangle) = \text{pr}_1(\langle a, b \rangle) \Delta^B \text{pr}_1(\langle a', b' \rangle)$$

This entails that $(\text{pr}_1 \circ v)(\psi \wedge \xi) = ((\text{pr}_1 \circ v)(\psi)) \Delta^B ((\text{pr}_1 \circ v)(\xi))$.

The case of disjunction can be inferred from the cases of negation and conjunction. Hence, the valuation $\text{pr}_1 \circ v$ maps formulae φ to appropriate values, *i.e.*, $\text{pr}_1 \circ v$ is a Kleene-Fitting valuation. \square

These lemmas entail a fundamental property of \neg_t -Kleene-Fitting valuations.

Observation 6.5.1. *If v_0 and v_1 are \neg_t -Kleene-Fitting valuations on logical trilattices $\langle \mathcal{A}_0 \odot \mathcal{B}_0, A_0 \times \mathcal{F}_0 \rangle$ and $\langle \mathcal{A}_1 \odot \mathcal{B}_1, A_1 \times \mathcal{F}_1 \rangle$, then if $v_0 \simeq_t v_1$, for all formulae $\varphi \in \mathcal{L}$, $v_0(\varphi) \simeq_t v_1(\varphi)$.*

Proof. By Lemma 6.5.1, $v_i(\psi) \in A_i \times \mathcal{F}_i$ stands or falls with the claim that $\text{pr}_1(v_i(\psi)) \in \mathcal{F}_i$ for each $i \in \{0, 1\}$. Moreover, by Lemma 6.5.2, $\text{pr}_1 \circ v_0$ and $\text{pr}_1 \circ v_1$ are Kleene-Fitting valuations on the logical bilattices $\langle \mathcal{B}_0, \mathcal{F}_0 \rangle$ and $\langle \mathcal{B}_1, \mathcal{F}_1 \rangle$, respectively. As a consequence, we may infer that for any formula φ , $v_0(\varphi) \simeq_t v_1(\varphi)$ if and only if $(\text{pr}_1 \circ v_0)(\varphi) \simeq (\text{pr}_1 \circ v_1)(\varphi)$.

Because this holds *a fortiori* when φ is an atom p , the hypothesis that $v_0 \simeq_t v_1$ thus entails that $\text{pr}_1 \circ v_0 \simeq \text{pr}_1 \circ v_1$. By applying Observation 6.2.8, we may infer that for an arbitrary φ , $(\text{pr}_1 \circ v_0)(\varphi) \simeq (\text{pr}_1 \circ v_1)(\varphi)$. But by our earlier observation, this entails that $v_0(\varphi) \simeq_t v_1(\varphi)$ and because φ was selected arbitrarily, this holds for all formulae φ . \square

Definition 6.5.6. *Recall the definition of the partition $\mathcal{T}_x^{\langle \mathcal{B}, \mathcal{F} \rangle}$ from Definition 6.2.7 and let $\langle \mathcal{A} \odot \mathcal{B}, A \times \mathcal{F}_B \rangle$ be a logical trilattice. Then the function $g_{\langle \mathcal{A} \odot \mathcal{B}, A \times \mathcal{F}_B \rangle} : A \times B \rightarrow \text{FOUR}_2 \times \text{FOUR}_2$ is defined so that:*

$$g_{\langle \mathcal{A} \odot \mathcal{B}, A \times \mathcal{F}_B \rangle}(x) = \langle \top, \text{ny} \cdot \text{pr}_1(x) \in \mathcal{T}_x^{\langle \mathcal{B}, \mathcal{F}_B \rangle} \rangle$$

Lemma 6.5.3. *If v is a \neg_t -Kleene-Fitting valuation on $\langle \mathcal{A} \odot \mathcal{B}, A \times \mathcal{F}_B \rangle$ with $\langle \mathcal{B}, \mathcal{F}_B \rangle$ a logical bilattice, then the valuation $g_{\langle \mathcal{A} \odot \mathcal{B}, A \times \mathcal{F}_B \rangle} \circ v$ is a valuation on $\langle \text{SIXTEEN}_3, \text{FOUR}_2 \times \{\top, \mathbf{t}\} \rangle$ such that $v \simeq_t g_{\langle \mathcal{A} \odot \mathcal{B}, A \times \mathcal{F}_B \rangle} \circ v$.*

Proof. By construction of $g_{\langle \mathcal{A} \odot \mathcal{B}, A \times \mathcal{F}_B \rangle}$, we can be assured that for all atoms p , $v(p) \simeq_t (g_{\langle \mathcal{A} \odot \mathcal{B}, A \times \mathcal{F}_B \rangle} \circ v)(p)$. Hence, by Observation 6.5.1, $v \simeq_t g_{\langle \mathcal{A} \odot \mathcal{B}, A \times \mathcal{F}_B \rangle} \circ v$. \square

Observation 6.5.2. *Consider a logical trilattice $\langle \mathcal{A} \odot \mathcal{B}, \mathcal{F} \rangle$ and a set of formulae $\Gamma \cup \{\varphi\} \subseteq \mathcal{L}$. Then we have the following:*

$$\Gamma \models_{\text{KF}[\neg_t]}^{\langle \mathcal{A} \odot \mathcal{B}, A \times \mathcal{F}_B \rangle} \varphi \text{ if and only if } \Gamma \models_{\text{KF}[\neg_t]}^{\langle \text{SLXTEEN}_3, \text{FOUR}_2 \times \{\top, \mathbf{t}\} \rangle} \varphi$$

Proof. If $\Gamma \not\models_{\text{KF}[\neg_t]}^{\langle \mathcal{A} \odot \mathcal{B}, A \times \mathcal{F}_B \rangle} \varphi$ and v is a \neg_t -Kleene-Fitting valuation witnessing the failure of this inference, then $g_{\langle \mathcal{A} \odot \mathcal{B}, A \times \mathcal{F}_B \rangle} \circ v$ is a valuation on $\langle \text{SLXTEEN}_3, \text{FOUR}_2 \times \{\top, \mathbf{t}\} \rangle$ such that for all $\varphi \in \mathcal{L}$, $v(\varphi) \simeq_t (g_{\langle \mathcal{A} \odot \mathcal{B}, A \times \mathcal{F}_B \rangle} \circ v)(\varphi)$. Hence, the \neg_t -Kleene-Fitting valuation $g_{\langle \mathcal{A} \odot \mathcal{B}, A \times \mathcal{F}_B \rangle} \circ v$ witnesses that $\Gamma \not\models_{\text{KF}[\neg_t]}^{\langle \text{SLXTEEN}_3, \text{FOUR}_2 \times \{\top, \mathbf{t}\} \rangle} \varphi$.

On the other hand, because SLXTEEN_3 is the smallest non-degenerate trilattice, the elements of FOUR_2 can be identified with the top and bottom elements of both \mathcal{A} and \mathcal{B} . Hence, any valuation on $\langle \text{SLXTEEN}_3, \text{FOUR}_2 \times \{\top, \mathbf{t}\} \rangle$ witnessing that $\Gamma \not\models_{\text{KF}[\neg_t]}^{\langle \text{SLXTEEN}_3, \text{FOUR}_2 \times \{\top, \mathbf{t}\} \rangle} \varphi$ is *a fortiori* a valuation on $\langle \mathcal{A} \odot \mathcal{B}, A \times \mathcal{F}_B \rangle$ that serves as a countermodel to the inference $\Gamma \models_{\text{KF}[\neg_t]}^{\langle \mathcal{A} \odot \mathcal{B}, A \times \mathcal{F}_B \rangle} \varphi$. \square

Lemma 6.5.4. *For all sets of formulae $\Gamma \cup \{\varphi\}$, we have the following:*

$$\Gamma \models_{\text{KF}[\neg_t]}^{\langle \text{SLXTEEN}_3, \text{FOUR}_2 \times \{\top, \mathbf{t}\} \rangle} \varphi \text{ if and only if } \Gamma \models_{\text{KF}}^{\langle \text{FOUR}_2, \{\top, \mathbf{t}\} \rangle} \varphi.$$

Proof. For left-to-right, suppose that $\Gamma \not\models_{\text{KF}[\neg_t]}^{\langle \text{SLXTEEN}_3, \text{FOUR}_2 \times \{\top, \mathbf{t}\} \rangle} \varphi$ and let v be a \neg_t -Kleene-Fitting valuation witnessing the failure of the inference. Then by Lemmas 6.5.1 and 6.5.2, $\text{pr}_1 \circ v$ is a Kleene-Fitting valuation on $\langle \text{FOUR}_2, \{\top, \mathbf{t}\} \rangle$ such that $(\text{pr}_1 \circ v)[\Gamma] \subseteq \{\top, \mathbf{t}\}$ although $(\text{pr}_1 \circ v)(\varphi) \notin \{\top, \mathbf{t}\}$. $\text{pr}_1 \circ v$ thus witnesses the fact that $\Gamma \not\models_{\text{KF}}^{\langle \text{FOUR}_2, \{\top, \mathbf{t}\} \rangle} \varphi$.

Conversely, if $\Gamma \not\models_{\text{KF}}^{\langle \text{FOUR}_2, \{\top, \mathbf{t}\} \rangle} \varphi$ and v is a Kleene-Fitting valuation witnessing this fact, then $v^* : x \mapsto \langle v(x), v(x) \rangle$ is clearly a \neg_t -Kleene-Fitting valuation. By appealing to Lemma 6.5.1, from $v[\Gamma] \subseteq \{\top, \mathbf{t}\}$ we can infer that $v^*[\Gamma] \subseteq \text{FOUR}_2 \times \{\top, \mathbf{t}\}$ and from $v(\varphi) \notin \{\top, \mathbf{t}\}$,

we infer that $v^*(\varphi) \notin FOUR_2 \times \{\top, \mathbf{t}\}$. But this is just to say that v^* witnesses that $\Gamma \not\vdash_{\mathbf{KF}[\neg_t]}^{\langle SL\mathcal{X}T\mathcal{E}\mathcal{E}\mathcal{N}_3, FOUR_2 \times \{\top, \mathbf{t}\} \rangle} \varphi$. \square

Observation 6.5.3. *Let $\langle \mathcal{T}, \mathcal{F} \rangle$ be a logical trilattice with a t -inversion where \mathcal{T} is interlaced. Then for all sets of formulae $\Gamma \cup \{\varphi\}$:*

$$\Gamma \vDash_{\mathbf{KF}[\neg_t]}^{\langle \mathcal{T}, \mathcal{F} \rangle} \varphi \text{ if and only if } \Gamma \vDash_{\mathbf{S}_{\mathbf{fde}}} \varphi$$

Proof. Suppose that $\Gamma \vDash_{\mathbf{KF}[\neg_t]}^{\langle \mathcal{T}, \mathcal{F} \rangle} \varphi$ and let v be a \neg_t -Kleene-Fitting valuation on $\langle \mathcal{T}, \mathcal{F} \rangle$ witnessing this fact. By Theorem 6.4.1, the trilattice \mathcal{T} is isomorphic to a product trilattice $A \odot B$ and by Observation 6.5.1, \mathcal{F} may be represented by the prime trifilter $A \times \mathcal{F}_B$. Hence, we infer equivalence with the proposition that $\Gamma \vDash_{\mathbf{KF}[\neg_t]}^{\langle A \odot B, A \times \mathcal{F}_B \rangle} \varphi$ where $\mathcal{F} = A \times \mathcal{F}_B$. By Lemma 6.5.1, this holds if and only if there exists an analogous \neg_t -Kleene-Fitting valuation on $\langle SL\mathcal{X}T\mathcal{E}\mathcal{E}\mathcal{N}_3, FOUR_2 \times \{\top, \mathbf{t}\} \rangle$ attesting to the proposition $\Gamma \vDash_{\mathbf{KF}[\neg_t]}^{\langle SL\mathcal{X}T\mathcal{E}\mathcal{E}\mathcal{N}_3, FOUR_2 \times \{\top, \mathbf{t}\} \rangle} \varphi$. Lemma 6.5.4 shows the equivalence between this proposition and $\Gamma \vDash_{\mathbf{KF}}^{\langle FOUR_2, \{\top, \mathbf{t}\} \rangle} \varphi$. Observation 6.2.10 ensures that this is equivalent to the claim that $\Gamma \vDash_{\mathbf{S}_{\mathbf{fde}}} \varphi$. \square

We thus observe that—given the most direct and natural generalization of cut-down operations to the case of trilattices—the interpretation of $\mathbf{S}_{\mathbf{fde}}$ as the logic of cut-down operations on bilattices lifts to the case of interlaced trilattices whenever negation is interpreted as t -inversion.

6.5.2 Interlude: Analytic Containment and $\mathbf{S}_{\mathbf{fde}}$

From a certain perspective, the relationship between the logics $\mathbf{S}_{\mathbf{fde}}$ and \mathbf{AC} might be expected to mirror that between bilattices and trilattices.

On the one hand, we have observed that Rivieccio’s representation theorem for interlaced trilattices of (163) proves that all interlaced trilattices are isomorphic to the product of two

bilattices. For example, for a generalization of the Fitting-Ginsberg product \odot , the trilattice $\mathcal{SIXTEEN}_3$ can be represented as the product trilattice $\mathcal{FOUR}_2 \odot \mathcal{FOUR}_2$.

On the other hand, whereas Chapter 5 described a Belnap-Dunn-like interpretation of AC as two systems of positive Σ_0 running in parallel (*i.e.*, calculating independent truth and falsity values), semantics for AC could just as easily have been provided by two systems of \mathbf{S}_{fde} . In this sense, the resulting sixteen-valued semantics for AC can be viewed as a *product* of the matrix for \mathbf{S}_{fde} with itself, with negation toggling between the two.

Lemma 6.5.5. *The positive fragments of Σ_0 and \mathbf{S}_{fde} coincide.*

Proof. Let \sim be the equivalence relation on $\mathcal{V}_{\mathbf{S}_{\text{fde}}}$ induced by the partition $\{\{\mathbf{t}, \mathbf{b}\}, \{\mathbf{u}\}, \{\mathbf{f}\}\}$. Then if we use the notation $f[x]$ to denote the image of x under f and the notation $[x]_{\sim}$ to denote the equivalence class of x under \sim , it is easy to confirm the following for all $\mathbf{v}, \mathbf{v}' \in \mathcal{V}_{\mathbf{S}_{\text{fde}}}$:

- $f_{\mathbf{S}_{\text{fde}}}^{\wedge} [[\mathbf{v}]_{\sim} \times [\mathbf{v}']_{\sim}] = [f_{\mathbf{S}_{\text{fde}}}^{\wedge}(\mathbf{v}, \mathbf{v}')]_{\sim}$
- $f_{\mathbf{S}_{\text{fde}}}^{\vee} [[\mathbf{v}]_{\sim} \times [\mathbf{v}']_{\sim}] = [f_{\mathbf{S}_{\text{fde}}}^{\vee}(\mathbf{v}, \mathbf{v}')]_{\sim}$

entailing that \sim is also a congruence relation. This also entails that we have the following truth tables for the images of equivalence classes of values of $\mathcal{V}_{\mathbf{S}_{\text{fde}}}$ under the truth functions of \mathbf{S}_{fde} :

$f_{\mathbf{S}_{\text{fde}}}^{\wedge}$	$\{\mathbf{t}, \mathbf{b}\}$	$\{\mathbf{u}\}$	$\{\mathbf{f}\}$	$f_{\mathbf{S}_{\text{fde}}}^{\vee}$	$\{\mathbf{t}, \mathbf{b}\}$	$\{\mathbf{u}\}$	$\{\mathbf{f}\}$
$\{\mathbf{t}, \mathbf{b}\}$	$\{\mathbf{t}, \mathbf{b}\}$	$\{\mathbf{u}\}$	$\{\mathbf{f}\}$	$\{\mathbf{t}, \mathbf{b}\}$	$\{\mathbf{t}, \mathbf{b}\}$	$\{\mathbf{u}\}$	$\{\mathbf{t}, \mathbf{b}\}$
$\{\mathbf{u}\}$	$\{\mathbf{u}\}$	$\{\mathbf{u}\}$	$\{\mathbf{u}\}$	$\{\mathbf{u}\}$	$\{\mathbf{u}\}$	$\{\mathbf{u}\}$	$\{\mathbf{u}\}$
$\{\mathbf{f}\}$	$\{\mathbf{f}\}$	$\{\mathbf{u}\}$	$\{\mathbf{f}\}$	$\{\mathbf{f}\}$	$\{\mathbf{t}, \mathbf{b}\}$	$\{\mathbf{u}\}$	$\{\mathbf{f}\}$

By appealing to the fact that both $\mathcal{V}_{\Sigma_0} \subseteq \mathcal{V}_{\mathbf{S}_{\text{fde}}}$ and $\mathcal{D}_{\Sigma_0} \subseteq \mathcal{D}_{\mathbf{S}_{\text{fde}}}$ and that there is a clear analogy between the above truth tables and those for conjunction and disjunction in Definition 2.2.4, it is easy to confirm that the function $h : \mathbf{v} \mapsto [\mathbf{v}]_{\sim}$ is an isomorphism between the positive matrix of Σ_0 and the quotient of the positive matrix of \mathbf{S}_{fde} under \sim .

□

Definition 6.5.7. *The relation $\vDash_{AC'}$ is the consequence relation induced by the matrix $\langle \mathcal{V}_{S_{fde}} \times \mathcal{D}_{S_{fde}} \times \mathcal{V}_{S_{fde}}, f_{AC'}^{\dot{\leftarrow}}, f_{AC'}^{\hat{\leftarrow}}, f_{AC'}^{\check{\leftarrow}} \rangle$ where:*

- $f_{AC'}^{\dot{\leftarrow}}(\langle \mathbf{v}_0, \mathbf{v}_1 \rangle) = \langle \mathbf{v}_1, \mathbf{v}_0 \rangle$
- $f_{AC'}^{\hat{\leftarrow}}(\langle \mathbf{v}_0, \mathbf{v}_1 \rangle, \langle \mathbf{v}'_0, \mathbf{v}'_1 \rangle) = \langle f_{S_{fde}}^{\hat{\leftarrow}}(\mathbf{v}_0, \mathbf{v}'_0), f_{S_{fde}}^{\check{\leftarrow}}(\mathbf{v}_1, \mathbf{v}'_1) \rangle$
- $f_{AC'}^{\check{\leftarrow}}(\langle \mathbf{v}_0, \mathbf{v}_1 \rangle, \langle \mathbf{v}'_0, \mathbf{v}'_1 \rangle) = \langle f_{S_{fde}}^{\check{\leftarrow}}(\mathbf{v}_0, \mathbf{v}'_0), f_{S_{fde}}^{\hat{\leftarrow}}(\mathbf{v}_1, \mathbf{v}'_1) \rangle$

AC' valuations and AC' validity are defined in the standard fashion.

Because the functions $f_{S_{fde}}^{\hat{\leftarrow}}$ and $f_{S_{fde}}^{\check{\leftarrow}}$ are unable to distinguish between the values \mathbf{t} and \mathbf{b} in positive S_{fde} , $\mathfrak{M}_{AC'}$ provides a correct characterization of Angell's AC as well.

Lemma 6.5.6. $\Gamma \vDash_{AC'} \varphi$ iff $\Gamma \vDash_{AC} \varphi$

Proof. Left-to-right is immediate. Suppose that $\Gamma \not\vDash_{AC} \varphi$ and that v is an AC valuation witnessing this fact. Then because $\mathcal{V}_{AC} \subseteq \mathcal{V}_{AC'}$, v is also an AC' valuation, whence $\Gamma \not\vDash_{AC'} \varphi$.

Right-to-left follows by invoking a trivial induction on complexity of formulae demonstrating that any AC' valuation has a corresponding AC valuation by mapping both \mathbf{t} and \mathbf{b} to \mathbf{t} . Any AC' countermodel to an inference $\Gamma \vDash_{AC'} \varphi$ entails the existence of an AC countermodel to $\Gamma \vDash_{AC} \varphi$.

□

This suggests that with respect to the generalization of cut-down operation on trilattices in Definitions 6.4.6 and 6.4.7, whenever negation is identified with tf -inversion, the account of S_{fde} on bilattices can be employed to provide a natural and robust correspondence between AC and cut down operations on interlaced trilattices.

6.5.3 AC on Trilattices

Now, granted the foregoing considerations on AC, we will show its equivalence to the logic of cut-down operations on trilattices in which negation is interpreted as a tf -inversion. Naturally, the modification of Kleene-Fitting valuations may be defined as follows:

Definition 6.5.8. *A \neg_{tf} -Kleene-Fitting valuation on a trilattice \mathcal{T} with t - and f -inversions is a function $v : \mathcal{L} \rightarrow T$ such that:*

- $v(\dot{\neg} \varphi) = \neg_{tf}(v(\varphi))$
- $v(\varphi \dot{\wedge} \psi) = v(\varphi) \Delta_t v(\psi)$
- $v(\varphi \dot{\vee} \psi) = v(\varphi) \nabla_t v(\psi)$

Definition 6.5.9. *An inference from Γ to φ is \neg_{tf} -KF valid on a logical trilattice $\langle \mathcal{T}, \mathcal{F} \rangle$ —written $\Gamma \vDash_{\text{KF}[\neg_{tf}]}^{\langle \mathcal{T}, \mathcal{F} \rangle} \varphi$ —if for all \neg_{tf} -Kleene-Fitting valuations v , if $v[\Gamma] \subseteq \mathcal{F}$ then $v(\varphi) \in \mathcal{F}$.*

For an interlaced trilattice \mathcal{T} with t - and f -inversions, the inversions \neg_t and \neg_f always commute. With an eye to the representation theorems, that \neg_t and \neg_f commute ensures that not only is every interlaced trilattice \mathcal{T} isomorphic to a product trilattice $\mathcal{A} \odot \mathcal{B}$ but that \mathcal{A} is isomorphic to \mathcal{B} . Hence, we will consider product trilattices $\mathcal{A} \odot \mathcal{A}$ in the following pages before applying Rivieccio's representation theorems (163) to extend the following observations to *all* interlaced trilattices with inversions \neg_t and \neg_f .

Again, we proceed by showing a correspondence between logical trilattices of the form $\langle \mathcal{A} \odot \mathcal{A}, \mathcal{F} \rangle$ and $\langle \text{FOUR}_2 \odot \text{FOUR}_2, \text{FOUR}_2 \times \{\top, \mathbf{t}\} \rangle$ before demonstrating a correspondence between the latter logical trilattice and AC. An essential ingredient in this correspondence is a final notion of similarity.

Definition 6.5.10. *Consider two logical trilattices $\langle \mathcal{A}_0 \odot \mathcal{A}_0, \mathcal{A}_0 \times \mathcal{F}_0 \rangle$ and $\langle \mathcal{A}_1 \odot \mathcal{A}_1, \mathcal{A}_1 \times \mathcal{F}_1 \rangle$ where \mathcal{F}_0 and \mathcal{F}_1 are prime bifilters on \mathcal{A}_0 and \mathcal{A}_1 , respectively. Then two elements $\langle a, b \rangle \in \mathcal{A}_0 \times \mathcal{A}_0$ and $\langle a', b' \rangle \in \mathcal{A}_1 \times \mathcal{A}_1$ are \neg_{tf} -similar—written $\langle a, b \rangle \simeq_{tf} \langle a', b' \rangle$ —if:*

- $\langle a, b \rangle \simeq_t \langle a', b' \rangle$, and
- $\neg_{tf} \langle a, b \rangle \simeq_t \neg_{tf} \langle a', b' \rangle$

Observation 6.5.4. For two logical trilattices $\langle \mathcal{A}_0 \odot \mathcal{A}_0, A_0 \times \mathcal{F}_0 \rangle$ and $\langle \mathcal{A}_1 \odot \mathcal{A}_1, A_1 \times \mathcal{F}_1 \rangle$, for all elements $\langle a, b \rangle \in A_0 \times A_0$ and $\langle a', b' \rangle \in A_1 \times A_1$,

$$\langle a, b \rangle \simeq_{tf} \langle a', b' \rangle \text{ if and only if } \begin{cases} b \simeq b', \text{ and} \\ a \simeq a' \end{cases}$$

where similarity simpliciter (i.e., \simeq) is considered with respect to logical bilattices $\langle \mathcal{A}_0, \mathcal{F}_0 \rangle$ and $\langle \mathcal{A}_1, \mathcal{F}_1 \rangle$.

Proof. An immediate consequence of Lemma 6.5.1 is that

$$\langle a, b \rangle \simeq_{tf} \langle a', b' \rangle \text{ holds if and only if } b \simeq b'.$$

Moreover, if we note that the claim that $\neg_{tf} \langle a, b \rangle \simeq_t \neg_{tf} \langle a', b' \rangle$ is equivalent to $\langle \neg b, \neg a \rangle \simeq_{tf} \langle \neg b', \neg a' \rangle$, Lemma 6.5.1 entails that this is equivalent to the statement that $\neg a \simeq \neg a'$, i.e., $a \simeq a'$. \square

As before, we again extend a notion of similarity to valuations on trilattices, although in this case, we consider \neg_{tf} -Kleene-Fitting valuations.

Definition 6.5.11. We say that two \neg_{tf} -Kleene-Fitting valuations v_0 and v_1 are \neg_{tf} -similar if for all atoms p :

$$v_0(p) \simeq_{tf} v_1(p)$$

And we prove a fundamental principle concerning \neg_{tf} -similar valuations.

Observation 6.5.5. Where v_0 and v_1 are \neg_{tf} -Kleene-Fitting valuations on logical trilattices $\langle \mathcal{A}_0 \odot \mathcal{A}_0, A_0 \times \mathcal{F}_0 \rangle$ and $\langle \mathcal{A}_1 \odot \mathcal{A}_1, A_1 \times \mathcal{F}_1 \rangle$ such that $v_0 \simeq_{tf} v_1$, $v_0(\varphi) \simeq_{tf} v_1(\varphi)$ for all formulae $\varphi \in \mathcal{L}$.

Proof. Suppose that v_0 and v_1 are \neg_{tf} -similar. Then we prove the observation by induction on complexity of formulae.

As induction hypothesis for two formulae $\varphi, \psi \in \mathcal{L}$, let $v_0(\varphi) = \langle a_0, b_0 \rangle$, $v_0(\psi) = \langle a_1, b_1 \rangle$, $v_1(\varphi) = \langle a'_0, b'_0 \rangle$, and $v_1(\psi) = \langle a'_1, b'_1 \rangle$ and assume that $v_0(\varphi) \simeq_{tf} v_1(\varphi)$ and $v_0(\psi) \simeq_{tf} v_1(\psi)$. More explicitly, by Observation 6.5.4, this entails that $a_0 \simeq a'_0$, $a_1 \simeq a'_1$, $b_0 \simeq b'_0$, and $b_1 \simeq b'_1$ all hold.

In the case of negation, involutivity of \neg_t ensures that the result holds. In particular, that $a_0 \simeq a'_0$ and $b_0 \simeq b'_0$ entails that $\neg a_0 \simeq \neg a'_0$ and $\neg b_0 \simeq \neg b'_0$, entailing that $\langle \neg b_0, \neg a_0 \rangle \simeq_{tf} \langle \neg b'_0, \neg a'_0 \rangle$, *i.e.*, $v_0(\dot{\neg} \varphi) \simeq_{tf} v_1(\dot{\neg} \varphi)$.

In the case of conjunction and disjunction, note that $v_0(\varphi \dot{\wedge} \psi) = \langle a_0 \Delta a_1, b_0 \Delta b_1 \rangle$ and $v_1(\varphi \dot{\wedge} \psi) = \langle a'_0 \Delta a'_1, b'_0 \Delta b'_1 \rangle$. By Observation 6.5.4, the matter of determining \neg_{tf} -similarity between $v_0(\varphi \dot{\wedge} \psi)$ and $v_1(\varphi \dot{\wedge} \psi)$ reduces to the matter of determining whether $a_0 \Delta a_1 \simeq a'_0 \Delta a'_1$ and $b_0 \Delta b_1 \simeq b'_0 \Delta b'_1$. Likewise, whether $v_0(\varphi \dot{\vee} \psi) \simeq_{tf} v_1(\varphi \dot{\vee} \psi)$ stands or falls alongside the matter of whether both $a_0 \Delta a_1 \simeq a'_0 \Delta a'_1$ and $b_0 \nabla b_1 \simeq b'_0 \nabla b'_1$ hold.

The details of Observation 6.2.8 ensure that if $a_0 \simeq a'_0$ and $a_1 \simeq a'_1$ both hold, then also $a_0 \Delta a_1 \simeq a'_0 \Delta a'_1$ and $a_0 \nabla a_1 \simeq a'_0 \nabla a'_1$ (and *mutatis mutandis* when $b_0 \simeq b'_0$ and $b_1 \simeq b'_1$). Hence, the induction hypothesis entails that $v_0(\varphi \dot{\wedge} \psi) \simeq_{tf} v_1(\varphi \dot{\wedge} \psi)$ and $v_0(\varphi \dot{\vee} \psi) \simeq_{tf} v_1(\varphi \dot{\vee} \psi)$. \square

Definition 6.5.12. Let $g'_{\langle \mathcal{A} \odot \mathcal{A}, \mathcal{A} \times \mathcal{F} \rangle} : A \times A \rightarrow FOUR_2 \times FOUR_2$ be defined so that:

$$g'_{\langle \mathcal{A} \odot \mathcal{A}, \mathcal{A} \times \mathcal{F} \rangle}(a, b) = \langle \neg(\iota x.a \in \mathcal{T}_x^{\langle \mathcal{A}, \mathcal{F} \rangle}), \iota y.b \in \mathcal{T}_y^{\langle \mathcal{A}, \mathcal{F} \rangle} \rangle.$$

Lemma 6.5.7. If v is a \neg_{tf} -Kleene-Fitting valuation on $\langle \mathcal{A} \odot \mathcal{A}, \mathcal{A} \times \mathcal{F} \rangle$ where $\langle \mathcal{A}, \mathcal{F} \rangle$ is a logical bilattice, then the function $g'_{\langle \mathcal{A} \odot \mathcal{A}, \mathcal{A} \times \mathcal{F} \rangle} \circ v$ is a \neg_{tf} -Kleene-Fitting valuation on $\langle SIXTEEN_3, FOUR_2 \times \{\top, \mathbf{t}\} \rangle$ such that $v \simeq_{tf} g'_{\langle \mathcal{A} \odot \mathcal{A}, \mathcal{A} \times \mathcal{F} \rangle} \circ v$.

Proof. The construction of $g'_{\langle \mathcal{A} \odot \mathcal{A}, \mathcal{A} \times \mathcal{F} \rangle}$ guarantees that $(g'_{\langle \mathcal{A} \odot \mathcal{A}, \mathcal{A} \times \mathcal{F} \rangle} \circ v)(p) \simeq_{tf} v(p)$ for each atom p , entailing that $g'_{\langle \mathcal{A} \odot \mathcal{A}, \mathcal{A} \times \mathcal{F} \rangle} \circ v \simeq_{tf} v$. \square

The sum of these observations swiftly yields the corollary that $\mathcal{SLXTEEN}_3$ retains its fundamental role in the theory of trilattices when negation is interpreted by \neg_{tf} .

The primary theorem will be proven by appealing to a sequence of equivalences described in the following observations:

Observation 6.5.6. *For a logical trilattice $\langle \mathcal{A} \odot \mathcal{A}, A \times \mathcal{F} \rangle$ and set of formulae $\Gamma \cup \{\varphi\}$, we have the following equivalence:*

$$\Gamma \models_{\text{KF}[\neg_{tf}]}^{\langle \mathcal{A} \odot \mathcal{A}, A \times \mathcal{F} \rangle} \varphi \text{ if and only if } \Gamma \models_{\text{KF}[\neg_{tf}]}^{\langle \mathcal{SLXTEEN}_3, \text{FOUR}_2 \times \{\top, \mathbf{t}\} \rangle} \varphi.$$

Proof. For right-to-left, suppose that $\Gamma \not\models_{\text{KF}[\neg_{tf}]}^{\langle \mathcal{A} \odot \mathcal{A}, A \times \mathcal{F} \rangle} \varphi$ and let v be a \neg_{tf} -Kleene-Fitting valuation such that $v[\Gamma] \subseteq A \times \mathcal{F}$ although $v(\varphi) \notin A \times \mathcal{F}$. Then by Lemma 6.5.7, we may infer that $(g'_{\langle \mathcal{A} \odot \mathcal{A}, A \times \mathcal{F} \rangle} \circ v)(\psi) \simeq_{tf} v(\psi)$ for each $\psi \in \Gamma \cup \{\varphi\}$, entailing that $(g'_{\langle \mathcal{A} \odot \mathcal{A}, A \times \mathcal{F} \rangle} \circ v)$ witnesses that $\Gamma \not\models_{\text{KF}[\neg_{tf}]}^{\langle \mathcal{SLXTEEN}_3, \text{FOUR}_2 \times \{\top, \mathbf{t}\} \rangle} \varphi$.

For left-to-right, we can without loss of generality assume that $\text{FOUR}_2 \subseteq A$ and that $\{\top, \mathbf{t}\} \subseteq \mathcal{F}$. Hence, a \neg_{tf} -Kleene-Fitting valuation v on $\mathcal{SLXTEEN}_3$ is *a fortiori* a valuation on $\mathcal{A} \odot \mathcal{A}$. Thus, whenever v serves as a countermodel to an inference $\Gamma \models_{\text{KF}[\neg_{tf}]}^{\langle \mathcal{SLXTEEN}_3, \text{FOUR}_2 \times \{\top, \mathbf{t}\} \rangle} \varphi$, v also serves as a countermodel to the inference $\Gamma \models_{\text{KF}[\neg_{tf}]}^{\langle \mathcal{A} \odot \mathcal{A}, A \times \mathcal{F} \rangle} \varphi$. \square

Observation 6.5.7. *For all sets of formulae $\Gamma \cup \{\varphi\}$, we have the following:*

$$\Gamma \models_{\text{KF}[\neg_{tf}]}^{\langle \mathcal{SLXTEEN}_3, \text{FOUR}_2 \times \{\top, \mathbf{t}\} \rangle} \varphi \text{ if and only if } \Gamma \models_{\text{AC}} \varphi.$$

Proof. Recall the bijection h^* between FOUR_2 and $\mathcal{V}_{\text{Sfde}}$ from the proof of Observation 6.2.2 and define the map $g^* : \text{FOUR}_2 \times \text{FOUR}_2 \rightarrow \mathcal{V}_{\text{Sfde}} \times \mathcal{V}_{\text{Sfde}}$ so that:

$$g^*(x, y) = \langle h^*(y), f_{\text{Sfde}}^{\rightarrow}(h^*(x)) \rangle.$$

To begin, there are several trivial observations that we can make. For one, it is clear that g^* is bijective. It is also immediate to note that the image of $\text{FOUR}_2 \times \{\top, \mathbf{t}\}$ under g^* is precisely the set of designated values of AC' .

What remains to be shown is that g^* preserves operations between the two structures. In the case of negation, this is relatively simple, with the steps in the following justification self-explanatory. Letting $\langle a, b \rangle \in FOUR_{R_2} \times FOUR_{R_2}$, we have the following:

$$\begin{aligned}
g^*(\neg_{tf}\langle a, b \rangle) &= g^*(\langle \neg b, \neg a \rangle) \\
&= \langle h^*(\neg a), f_{\mathcal{S}_{fde}}^{\dot{\neg}}(h^*(\neg b)) \rangle \\
&= \langle f_{\mathcal{S}_{fde}}^{\dot{\neg}}(h^*(a)), f_{\mathcal{S}_{fde}}^{\dot{\neg}}(f_{\mathcal{S}_{fde}}^{\dot{\neg}}(h^*(b))) \rangle \\
&= \langle f_{\mathcal{S}_{fde}}^{\dot{\neg}}(h^*(a)), h^*(b) \rangle \\
&= f_{\mathcal{AC}'}^{\dot{\neg}}(\langle h^*(b), f_{\mathcal{S}_{fde}}^{\dot{\neg}}(h^*(a)) \rangle) \\
&= f_{\mathcal{AC}'}^{\dot{\neg}}(g^*(\langle a, b \rangle))
\end{aligned}$$

It follows that if v_0 is a \neg_{tf} -Kleene-Fitting valuation on $\mathcal{SLXTEEN}_3$ and v_1 is an \mathcal{AC}' valuation such that $g^*(v_0(\varphi)) = v_1(\varphi)$, then:

$$g^*(v_0(\dot{\neg}\varphi)) = g^*(\neg_{tf}v_0(\varphi)) = f_{\mathcal{AC}'}^{\dot{\neg}}(v_1(\varphi)) = v_1(\dot{\neg}\varphi)$$

Likewise, in the case of weak conjunction,

$$\begin{aligned}
g^*(\langle a, b \rangle \Delta_t \langle a', b' \rangle) &= g^*(\langle a \Delta a', b \Delta b' \rangle) \\
&= \langle h^*(b \Delta b'), f_{\mathcal{S}_{fde}}^{\dot{\neg}}(h^*(a \Delta a')) \rangle \\
&= \langle f_{\mathcal{S}_{fde}}^{\dot{\wedge}}(h^*(b), h^*(b')), f_{\mathcal{S}_{fde}}^{\dot{\neg}}(f_{\mathcal{S}_{fde}}^{\dot{\wedge}}(h^*(a), h^*(a'))) \rangle \\
&= \langle f_{\mathcal{S}_{fde}}^{\dot{\wedge}}(h^*(b), h^*(b')), f_{\mathcal{S}_{fde}}^{\dot{\vee}}(f_{\mathcal{S}_{fde}}^{\dot{\neg}}(h^*(a)), f_{\mathcal{S}_{fde}}^{\dot{\neg}}(h^*(a'))) \rangle \\
&= f_{\mathcal{AC}'}^{\dot{\wedge}}(\langle h^*(b), f_{\mathcal{S}_{fde}}^{\dot{\neg}}(h^*(a)) \rangle, \langle h^*(b'), f_{\mathcal{S}_{fde}}^{\dot{\neg}}(h^*(a')) \rangle) \\
&= f_{\mathcal{AC}'}^{\dot{\wedge}}(g^*(\langle a, b \rangle), g^*(\langle a', b' \rangle))
\end{aligned}$$

Now, consider \neg_{tf} -Kleene-Fitting and \mathcal{AC}' valuations v_0 and v_1 , respectively, where $g^*(v_0(\varphi)) = v_1(\varphi)$ and $g^*(v_0(\psi)) = v_1(\psi)$. Then:

$$g^*(v_0(\varphi \dot{\wedge} \psi)) = g^*(v_0(\varphi) \Delta v_0(\psi)) = f_{\mathcal{AC}'}^{\dot{\wedge}}(v_1(\varphi), v_1(\psi)) = v_1(\varphi \dot{\wedge} \psi).$$

Hence, given a \neg_{tf} -Kleene-Fitting valuation v on $\mathcal{SLXTEEN}_3$ serving to demonstrate that $\Gamma \not\models_{\text{KF}[\neg_{tf}]}^{\langle \mathcal{SLXTEEN}_3, FOUR_{R_2} \times \{\top, \dagger\} \rangle} \varphi$, the function $g^* \circ v$ is an \mathcal{AC}' valuation acting as a countermodel

to the inference $\Gamma \vDash_{AC'} \varphi$. But Lemma 6.5.6 establishes that AC' consequence is identical to AC consequence, whence $\Gamma \not\vDash_{AC} \varphi$.

Likewise, if $\Gamma \not\vDash_{AC} \varphi$ then there exists an AC' valuation such that $v[\Gamma] \subseteq \mathcal{D}_{AC'}$ and $v(\varphi) \notin \mathcal{D}_{AC'}$. But as g^* is an isomorphism, the function $(g^*)^{-1} \circ v$ will be a \neg_{tf} -Kleene-Fitting valuation establishing that $\Gamma \not\vDash_{\text{KF}[\neg_{tf}]}^{\langle SL\mathcal{X}\mathcal{T}\mathcal{E}\mathcal{E}\mathcal{N}_3, \text{FOUR}_{R_2 \times \{\top, \text{t}\}} \rangle} \varphi$.

□

Theorem 6.5.1. *Let $\langle \mathcal{T}, \mathcal{F} \rangle$ be a logical trilattice with inversions \neg_t and \neg_f where \mathcal{T} is interlaced. Then for all sets of formulae $\Gamma \cup \{\varphi\} \subseteq \mathcal{L}$,*

$$\Gamma \vDash_{\text{KF}[\neg_{tf}]}^{\langle \mathcal{T}, \mathcal{F} \rangle} \varphi \text{ if and only if } \Gamma \vDash_{AC} \varphi$$

Proof. By Rivieccio's Theorem 6.4.2 and Lemma 6.4.2, $\langle \mathcal{T}, \mathcal{F} \rangle$ is isomorphic to a logical trilattice $\langle \mathcal{A} \odot \mathcal{A}, \mathcal{A} \times \mathcal{F} \rangle$. We may then appeal to Observations 6.5.6 and 6.5.7 to prove equivalence between consequence with respect to \neg_{tf} -Kleene-Fitting valuations on $\langle \mathcal{T}, \mathcal{F} \rangle$ and consequence in AC . □

Hence, whenever negation is identified with the inversion \neg_{tf} , the logic of cut down operations on interlaced trilattices is captured by Angell's AC .

6.6 Future Directions

There are two promising directions in which the foregoing work on cut-downs can be taken. Obviously, the results of Section 6.5 are limited insofar as the correspondences described therein hold only for *interlaced* trilattices. Although interlacing is a very natural property, it is obviously desirable to improve these results to hold for *all* logical trilattices.

A further limitation lies in the fact that the results in Section 6.3 are limited insofar as the observations apply only to the bilattice $\mathcal{NIN}\mathcal{E}_2$. Of course, there are numerous possible generalizations of Damásio and Pereira's operation of not to bilattices in general.

The question of how to generalize **not** and how the generalized operations relate to **AC** in general is worth pursuing.

In Chapter 5, we had considered Shramko and Wansing’s appeal to $\mathcal{SLXTEEN}_3$ as a representation of the logic of *networks* of Belnap computers in (175). If trilattices indeed constitute a natural model for such Shramko-Wansing networks, Angell’s **AC** emerges naturally in both the context of Belnap computers and networks of such computers. From an interpretative standpoint, then, it is plausible there is a corresponding interpretation of **AC** as the logic of faulty Shramko-Wansing networks, *i.e.*, networks of Belnap computers in which catastrophic errors may occur.

Finally, we have seen a host of other many-valued logics qualifying as ‘Parry.’ Whether bilattice semantics can be given for these systems is worth investigating. For example, given the interpretation of the Daniels-Priest logic $\mathbf{S}_{\text{fde}}^*$ as the logic of faulty Belnap computers in Chapter 5, one might anticipate that it would have been *this* system—rather than the Deutsch-Oller system \mathbf{S}_{fde} —that arises in the context of cut down operations on multilattices. It is worth investigating whether $\mathbf{S}_{\text{fde}}^*$ corresponds to any salient operations on multilattices.

At this point, we have considered a number of semantical frameworks within which Angell’s **AC** can be defined. In the next chapter, we revisit the first semantics for **AC**, described by Fabrice Correia in (49).

Chapter 7

Correia Semantics Revisited

Despite a renewed interest in Angell’s logic of *analytic containment* (AC), Correia’s semantics for AC has remained largely unexamined. This chapter describes a reasonable approach to Correia semantics by means of a correspondence with a nine-valued semantics for AC. The present inquiry employs this correspondence to provide characterizations of a number of propositional logics intermediate between AC and classical logic. In particular, we examine Correia’s purported characterization of classical logic with respect to his semantics, showing the condition Correia cites in fact characterizes the ‘logic of paradox’ LP and provide a correct characterization. Finally, we consider some remarks on related matters, such as the applicability of the present correspondence to the analysis of the system AC* and an intriguing relationship between Correia’s models and articular models for first-degree entailment.

7.1 Introduction

In (9) and (11), Richard Angell introduced the systems AC and AC* corresponding to a notion of *analytic containment* in which entailment is characterized as the containment of one proposition within another. Although Correia provided the first semantical account of

AC in (49), the semantics was not accompanied by any intuitive interpretation. Although many of the more recent interpretations have come equipped with corresponding semantics for AC, the object of study in this discussion is Correia's semantics of (49).

Although Correia describes the semantics of (49) as 'unusual,' the framework still appears to be authentically semantic in nature, that is, at first blush, the models are not merely a clever trick to transform syntax into semantics. Importantly, Correia's first semantics is not specific merely to AC, but, as Correia shows, provides a framework within which other deductive systems may be characterized. As an ill-understood semantical framework that captures the behavior of multiple deductive systems, Correia's semantics deserves deeper investigation; such an investigation has so far been missing.

In the present study, the correspondence between the nine-valued, truth functional semantics described in Chapter 5 and Correia's models is examined anew. This correspondence yields not only a simple avenue towards further characterizations of deductive systems in terms of Correia's models but insight into these properties and why they emerge in Correia semantics.

7.2 Analytic Containment and Correia Semantics

In this section, we will first examine the proof-theoretical account of analytic containment before proceeding to examine two semantical approaches: the account of Correia models introduced in (49) and the many-valued account introduced in (74). Further semantics have appeared in recent years but will not be reproduced here; the reader is referred to (50), (87), or (115) for accounts of these alternative approaches to AC.

7.2.1 Semantical Preliminaries

We have described Correia's semantics for AC in Section 5.3.1 but are now interested not only in how this semantics characterizes AC, but the conditions under which other deductive systems may be captured. To this end, we will have to consider a more general notion of validity in which only restricted classes of Correia models are considered.

Definition 7.2.1. *We say that a formula $A \rightarrow B$ is valid with respect to a class of Correia models \mathbf{X} if for all $\mathfrak{v} \in \mathbf{X}$ such that $\emptyset \models_{\mathfrak{v}} A$, $\emptyset \models_{\mathfrak{v}} B$.*

Definition 7.2.2. *A first-degree logic L is characterized by a set \mathbf{X} of Correia models if*

$$A \rightarrow B \text{ is a theorem of } L \text{ iff } A \rightarrow B \text{ is valid with respect to } \mathbf{X}.$$

Given the correspondence between the many-valued semantics for AC and vocabulary closed Correia models, it will aid us to represent extensions of AC in a similar, bilateral manner. Hence, we will provide bilateral semantics for a host of systems as restrictions on the matrix \mathfrak{M}_{AC} . For example, we have considered two presentations of E_{fde} : The unilateral account in Definition 3.1.17 and the bilateral account in Definition 5.2.1. In the latter case, the set of bilateral truth values $\mathcal{V}_{E_{fde}}^*$ is a subset of \mathcal{V}_{AC} . Hence, the logical matrix of Definition 5.2.1 can be thought of as a *restriction* of the matrix \mathfrak{M}_{AC} of Definition 5.2.3.

Formally, we define the restriction of a logical matrix as follows:

Definition 7.2.3. *With respect to a logical matrix $\mathfrak{M} = \langle \mathcal{V}, \mathcal{D}, f^{\dot{\cdot}}, f^{\check{\cdot}}, f^{\wedge} \rangle$, suppose that there exists a set $\mathcal{U} \subseteq \mathcal{V}$ such that \mathcal{U} is closed under $f^{\dot{\cdot}}$, $f^{\check{\cdot}}$, and f^{\wedge} . Then the restriction of \mathfrak{M} to the set \mathcal{U} is the matrix*

$$\mathfrak{M} \upharpoonright_{\mathcal{U}} = \langle \mathcal{U}, \mathcal{D} \cap \mathcal{U}, f^{\dot{\cdot}} \upharpoonright_{\mathcal{U}}, f^{\check{\cdot}} \upharpoonright_{(\mathcal{U} \times \mathcal{U})}, f^{\wedge} \upharpoonright_{(\mathcal{U} \times \mathcal{U})} \rangle.$$

Recall the Bochvar-Kleene logic Σ_0 from Definition 2.2.4. Eventually, we will reexamine Σ_0 , although its semantics will be formulated as a restriction of AC rather than the system from

which AC is built. As we will have cause to return to Σ_0 in the sequel, it is fitting to let this second presentation of Σ_0 illustrate the restriction of the matrix \mathfrak{M}_{AC} .

Observation 7.2.1. *Let $\mathcal{V}_{\Sigma_0}^* = \{\langle t, f \rangle, \langle f, t \rangle, \langle u, u \rangle\}$. Then*

$$\mathfrak{M}_{\Sigma_0} \cong \mathfrak{M}_{AC} \upharpoonright_{\mathcal{V}_{\Sigma_0}^*}$$

Proof. Let pr_0 and pr_1 be the projection operators projecting ordered pairs to their first and second elements, respectively. Simple calculation confirms that pr_0 is an isomorphism, that is, $\text{pr}_0(f_{AC}^{\dot{\leftarrow}}(\langle \mathbf{v}, \mathbf{v}' \rangle)) = f_{AC}^{\dot{\leftarrow}} \upharpoonright_{\mathcal{V}_{\Sigma_0}^*}(\text{pr}_0(\langle \mathbf{v}, \mathbf{v}' \rangle))$ and *mutatis mutandis* for conjunction and disjunction. \square

7.2.2 Correlating the Two Semantics

In Chapter 5, completeness of the nine-valued semantics was proven indirectly by means of a construction showing that if $A \rightarrow B$ is a valid inference by the lights of the nine-valued semantics, it is valid with respect to vocabulary closed Correia models as well. This construction, however, provides a useful platform from which we may characterize other notions of entailment in terms of Correia's models. This section introduces the construction and describes how it serves to interpret Correia's models.

Before reviewing the construction of Chapter 5, it will be helpful to review and introduce some properties of vocabulary closed Correia models. For example, we characterize the class of vocabulary closed Correia models in a fashion alternative to that of Definition 5.3.7:

Theorem 7.2.1. *A Correia model \mathbf{v} is vocabulary closed iff*

$$\mathbf{v} = \{\langle \Gamma, \Delta \rangle \mid \exists \langle \Gamma', \Delta' \rangle \in \mathfrak{G}(\mathbf{v}) \text{ s.t. } \langle \Gamma', \Delta' \rangle \preceq \langle \Gamma, \Delta \rangle \preceq \langle \Gamma_v^*, \Delta_v^* \rangle\}.$$

Proof. Immediate from Definition 5.3.7 and Lemma 5.3.6. \square

Hence, that \mathbf{v} is vocabulary closed is to say \mathbf{v} is determined precisely by its set of generators and its positive and negative vocabularies. This entails that when \mathbf{v} is vocabulary closed, all the information in \mathbf{v} can be recovered from $\mathfrak{G}(\mathbf{v})$ and $\langle \Gamma_{\mathbf{v}}^*, \Delta_{\mathbf{v}}^* \rangle$.

The set $\mathfrak{G}(\mathbf{v})$ is essential in the correspondence between Correia models and the nine-valued semantics. In this section, we will describe elements of the correspondence necessary to the present study. Now, Definition 5.3.14 provided us a truth-preserving method of translating Correia models into AC valuations that preserves truth. If we want to study further correspondences, however, it will be necessary to have a technique to translate AC valuations into Correia models whose theories are identical. This Correia model will be called a *Correia counterpart*:

Definition 7.2.4. *Let v be an AC valuation. Then the Correia counterpart of v is the unique vocabulary closed Correia model $\mathbf{c}(v)$ where:*

- $\langle \Gamma_{\mathbf{c}(v)}^*, \Delta_{\mathbf{c}(v)}^* \rangle = \langle \{p \mid \text{pr}_1(v(p)) \neq \mathbf{u}\}, \{p \mid \text{pr}_0(v(p)) \neq \mathbf{u}\} \rangle$
- $\langle \emptyset, \{p\} \rangle \in \mathbf{c}(v)$ iff $v(p) \in \mathcal{D}_{\text{AC}}$
- $\langle \{p\}, \emptyset \rangle \in \mathbf{c}(v)$ iff $v(\dot{\neg} p) \in \mathcal{D}_{\text{AC}}$

Theorem 7.2.2. $\emptyset \models_{\mathbf{c}(v)} A$ iff $v(A) \in \mathcal{D}_{\text{AC}}$.

Proof. It can be confirmed that $\mathfrak{F}(\mathbf{c}(v))$ is a singleton. Then $\emptyset \models_{\mathbf{c}(v)} A$ holds iff $\emptyset \Vdash_{\mathfrak{F}(\mathbf{c}(v))} A$ holds. But by Lemma 5.3.13, this is equivalent to saying that $v(A) \in \mathcal{D}_{\text{AC}}$. \square

7.2.3 A General Characterization Lemma

While characterizing different deductive systems by classes of Correia models, we employ a similar scheme of proof for each case. Rather than rehearse a virtually identical proof several times over, we will prove a lemma to which we may appeal when necessary.

Lemma 7.2.1 (Characterization Lemma). *Let L be a first-degree logic characterized by a matrix \mathfrak{M}_L such that \mathfrak{M}_L a restriction of \mathfrak{M}_{AC} and let Φ be a property of some vocabulary closed Correia models. Moreover, let the following two conditions hold:*

- *whenever \mathfrak{v} has property Φ then each $v_C \in \mathfrak{F}(\mathfrak{v})$ is an \mathfrak{M}_L valuation*
- *whenever v is an \mathfrak{M}_L valuation then $c(v)$ has property Φ*

Then L is characterized by the class of vocabulary closed models with property Φ .

Proof. Suppose that L is such a restriction of AC and that the two conditions hold. Then to prove that L is characterized by the class of vocabulary closed models satisfying property Φ is to prove that $A \rightarrow B$ is a theorem of L iff for all vocabulary closed Correia models \mathfrak{v} with property Φ , whenever $\emptyset \models_{\mathfrak{v}} A$, also $\emptyset \models_{\mathfrak{v}} B$.

For left-to-right, we prove the contrapositive. Suppose that there exists a vocabulary closed Correia model satisfying Φ such that $\emptyset \models_{\mathfrak{v}} A$ but $\emptyset \not\models_{\mathfrak{v}} B$. Then by Lemma 5.3.13, there exists a $v_C \in \mathfrak{F}(\mathfrak{v})$ such that $v_C(A) \in \mathcal{D}_{AC}$ but $v_C(B) \notin \mathcal{D}_{AC}$. By hypothesis, however, v_C is an L valuation and—as a restriction of AC —this entails that $v_C(A) \in \mathcal{D}_L$ but $v_C(B) \notin \mathcal{D}_L$. Hence, v_C is an L valuation witnessing the failure of $A \rightarrow B$ in L .

For right-to-left, we again prove the contrapositive. Let $A \rightarrow B$ fail to be a theorem of L and let v be an L valuation witnessing this fact. Then as L is by hypothesis a restriction of AC , v is trivially an AC valuation. Now consider $c(v)$. By Theorem 7.2.2, $\emptyset \models_{c(v)} A$ although $\emptyset \not\models_{c(v)} B$. But $c(v)$ by hypothesis has property Φ , whence we infer the existence of a vocabulary closed model with property Φ at which A is true but B is not true. \square

7.3 Correia Models and Other Propositional Logics

AC admits many equivalent presentations, one in which we are concerned with the validity of formulae $A \rightarrow B$ from $\mathcal{L}_{\text{fdef}}$ (e.g., the presentation in (49) or (87)) and the other in

which we are concerned with validity of an inference $\Gamma \vDash_{\text{AC}} B$ for $\Gamma \subseteq \mathcal{L}_{\text{zdf}}$ and $B \in \mathcal{L}_{\text{zdf}}$. Similarly, many propositional logics described in terms of a consequence relation also admit a formulation as a first-degree deductive system.

The contributions of Correia's (49) go beyond a characterization of AC in terms of his models; he also purports to characterize both the Belnap-Dunn logic \mathbf{E}_{fde} and the classical logic CL itself in terms of classes of his models.

In this section, we employ the interpretation of Correia models as sets of truth functions in order to characterize a number of deductive systems intermediate between AC and CL. Initially, we will examine Correia's characterization of the Belnap-Dunn logic of first-degree entailment \mathbf{E}_{fde} to make clear the utility and methodology of interpreting Correia models as collections of truth functions. Then, we will proceed to characterize some other first-degree logics in terms of Correia models. Finally, we will examine Correia's characterization of classical logic, showing it to be incorrect and providing a correct characterization of classical logic in the framework of (49).

7.3.1 First-Degree Entailment

Within the many-valued framework, the bilateral semantics for the logic \mathbf{E}_{fde} of Definition 5.2.1 can be viewed as a restriction of the nine-valued AC semantics in which the set of truth values are restricted to those corresponding to *truth*, *falsity*, *both true and false*, and *neither true nor false*.

Formally, this identity is expressed by the following observation:

Observation 7.3.1. $\mathfrak{M}_{\mathbf{E}_{\text{fde}}}^* = \mathfrak{M}_{\text{AC}} \upharpoonright \mathcal{V}_{\mathbf{E}_{\text{fde}}}^*$

Note that $\mathcal{V}_{\mathbf{E}_{\text{fde}}}^*$ is closed under the truth functions of AC; this will be the case for every restriction of AC considered in the sequel.

From a proof-theoretic perspective, as verified in (49), \mathbf{E}_{fde} can be obtained from AC by

adding the axiom $A \rightarrow A \dot{\vee} B$. In (49), Correia also provides a characterization of \mathbf{E}_{fde} with respect to Correia models satisfying the following condition:

Definition 7.3.1 (Condition TE). *For all finite sets of atoms Γ, Γ', Δ , and Δ' if $\langle \Gamma, \Delta \rangle \in \mathbf{v}$ then $\langle \Gamma \cup \Gamma', \Delta \cup \Delta' \rangle \in \mathbf{v}$*

To analyze Correia's result and provide similar characterizations to other deductive systems, we introduce a property equivalent to Condition TE.

Definition 7.3.2. *The language closure of a Correia model \mathbf{v} —symbolized $\llbracket \mathbf{v} \rrbracket$ —is the smallest Correia model \mathbf{v}' extending \mathbf{v} such that*

- *for all Correia pairs $\langle \Gamma, \Delta \rangle$, if there exists a $\langle \Gamma', \Delta' \rangle \in \mathbf{v}$ such that $\langle \Gamma', \Delta' \rangle \preceq \langle \Gamma, \Delta \rangle$, then $\langle \Gamma, \Delta \rangle \in \mathbf{v}'$*

I.e., the set $\{\langle \Gamma, \Delta \rangle \mid \exists \langle \Gamma', \Delta' \rangle \in \mathbf{v} \text{ s.t. } \langle \Gamma', \Delta' \rangle \preceq \langle \Gamma, \Delta \rangle \preceq \langle \mathbf{At}, \mathbf{At} \rangle\}$. We say that a Correia model \mathbf{v} is language closed if $\mathbf{v} = \llbracket \mathbf{v} \rrbracket$.

It is clear that these are equivalent conditions.

Observation 7.3.2. *\mathbf{v} is language closed iff \mathbf{v} enjoys Condition TE.*

In order to demonstrate the utility Lemma 7.2.1, we will prove Correia's result by means of the following lemmas.

Lemma 7.3.1. *If \mathbf{v} is language closed then for all $v_C \in \mathfrak{F}(\mathbf{v})$, v_C is an \mathbf{E}_{fde} valuation.*

Proof. Suppose that \mathbf{v} is a language closed Correia model. Then for all $p \in \mathbf{At}$, $p \in \Delta_{\mathbf{v}}^*$ and $p \in \Gamma_{\mathbf{v}}^*$. Hence, for any $C \in \prod(\mathfrak{G}(\mathbf{v})^\tau)$, we observe that both $\text{pr}_0(v_C(p)) \neq \mathbf{u}$, and $\text{pr}_1(v_C(p)) \neq \mathbf{u}$. Hence, the range of v_C is necessarily a subset of $\{\langle \mathbf{t}, \mathbf{f} \rangle, \langle \mathbf{f}, \mathbf{t} \rangle, \langle \mathbf{t}, \mathbf{t} \rangle, \langle \mathbf{f}, \mathbf{f} \rangle\}$, i.e., the range of v_C is a subset of $\mathcal{V}_{\mathbf{E}_{\text{fde}}}^*$. But this is just to say that v_C is a bilateral \mathbf{E}_{fde} valuation. \square

Lemma 7.3.2. *If v is a bilateral \mathbf{E}_{fde} valuation, then $\mathbf{c}(v)$ is language closed.*

Proof. Let v be a bilateral \mathbf{E}_{fde} valuation; for no atomic formula p is either $\text{pr}_0(v(p)) = \mathbf{u}$ or $\text{pr}_1(v(p)) = \mathbf{u}$. Now, as neither coordinate of the value of any atom p is \mathbf{u} , $\Gamma_{\mathbf{c}(v)}^* = \Delta_{\mathbf{c}(v)}^* = \mathbf{At}$. As $\mathbf{c}(v)$ is by construction vocabulary closed so that all atomic formulae appear in both its positive and negative vocabularies, it follows that $\mathbf{c}(v)$ is language closed. \square

With the assistance of Lemma 7.2.1, Lemmas 7.3.1 and 7.3.2 yield the theorem immediately.

Theorem 7.3.1. *\mathbf{E}_{fde} is characterized by the class of language closed Correia models.*

By following this general strategy, we are able to provide natural characterizations of numerous deductive systems in terms of Correia semantics.

First, we will examine ‘analytic’ extensions of \mathbf{AC} —those sharing a strong relevance property to be described in the sequel—before characterizing a few non-‘analytic’ extensions. Finally, we will turn our attention to the proper characterization of classical logic.

7.3.2 ‘Analytic’ Extensions

We have noted that \mathbf{AC} is ‘analytic’ in the sense employed by Parry, *i.e.*, that \mathbf{AC} enjoys the Proscriptive Principle. We have already encountered other first-degree logics that are ‘analytic’ in this sense which may be characterized in a bilateral fashion as restrictions of $\mathfrak{M}_{\mathbf{AC}}$. Two such systems that admit an analysis in terms of Correia models are $\mathbf{S}_{\text{fde}}^*$ described in (55) and \mathbf{S}_{fde} described in (58)—the first-degree fragments of Charles Daniels’ ‘story semantics’ of (54) and Harry Deutsch’s logic \mathbf{S} of (59).

We will thus provide bilateral semantics for these two systems as restrictions of $\mathfrak{M}_{\mathbf{AC}}$:

Definition 7.3.3. *A bilateral semantics is given for the first-degree formulation of $\mathbf{S}_{\text{fde}}^*$ by the matrix $\mathfrak{M}_{\mathbf{S}_{\text{fde}}^*} = \mathfrak{M}_{\mathbf{AC}} \upharpoonright_{\mathcal{V}_{\mathbf{S}_{\text{fde}}^*}^*}$ where*

$$\mathcal{V}_{\mathbf{S}_{\text{fde}}^*}^* = \{\langle \mathbf{t}, \mathbf{t} \rangle, \langle \mathbf{t}, \mathbf{f} \rangle, \langle \mathbf{f}, \mathbf{t} \rangle, \langle \mathbf{f}, \mathbf{f} \rangle, \langle \mathbf{u}, \mathbf{u} \rangle\}$$

Definition 7.3.4. A bilateral semantics is given for the first-degree formulation of S_{fde} by the matrix $\mathfrak{M}_{S_{\text{fde}}} = \mathfrak{M}_{\text{AC}} \upharpoonright_{\mathcal{V}_{S_{\text{fde}}}^*}$ where

$$\mathcal{V}_{S_{\text{fde}}}^* = \{\langle \mathbf{t}, \mathbf{t} \rangle, \langle \mathbf{t}, \mathbf{f} \rangle, \langle \mathbf{f}, \mathbf{t} \rangle, \langle \mathbf{u}, \mathbf{u} \rangle\}$$

Note that we are employing the decoration of \star to indicate that the set of truth values considered is bilateral.

The distinction between these systems and AC may be illustrated by examining the theorems that hold in the stronger logics. For example, the formula $A \rightarrow A \dot{\vee} \dot{\neg} A$ fails in AC, as the fact that $v(A) \in \mathcal{D}_{\text{AC}}$ is not sufficient to guarantee that $\text{pr}_1(v(A)) \neq \mathbf{u}$; on the ‘nonsense’ reading of the truth value \mathbf{u} (as in (31)), this is to say that the *positive content* of a proposition may be meaningful while its *negative content* is not. However, simple calculation confirms that this formula is in fact a theorem of S_{fde}^* , as the meaningfulness of a proposition and its negation stand or fall together.

On the interpretation of, e.g., (23) and (24), S_{fde} results from S_{fde}^* by eliminating the possibility of a proposition’s being neither true nor false by fiat. Hence, the mere mention of a proposition B entails that *tertium non datur* holds of B ; this is captured by a restricted excluded middle, witnessed by the validity of the formula $A \dot{\vee} B \rightarrow B \dot{\vee} \dot{\neg} B$ in S_{fde} .

Let us proceed to characterize these systems with respect to Correia semantics. First we will examine properties corresponding to S_{fde}^* .

Definition 7.3.5. A Correia model \mathbf{v} is unsigned if $\Gamma_{\mathbf{v}}^* = \Delta_{\mathbf{v}}^*$.

Lemma 7.3.3. If \mathbf{v} is an unsigned and vocabulary closed Correia model then for all $v_C \in \mathfrak{F}(\mathbf{v})$, v_C is a bilateral S_{fde}^* valuation.

Proof. Let \mathbf{v} be an unsigned and vocabulary closed valuation. Then for each $v_C \in \mathfrak{F}(\mathbf{v})$, v_C is an AC valuation by definition. However, for an atomic formula p , as $\Gamma_{\mathbf{v}}^* = \Delta_{\mathbf{v}}^*$, we observe that

$$\text{pr}_0(v_C(p)) = \mathbf{u} \text{ iff } p \notin \Gamma_{\mathbf{v}}^* \text{ iff } p \notin \Delta_{\mathbf{v}}^* \text{ iff } \text{pr}_1(v_C(p)) = \mathbf{u}.$$

Hence, the first coordinate of a truth value $v_C(A)$ is \mathbf{u} iff its second coordinate is \mathbf{u} . This strikes $\langle \mathbf{t}, \mathbf{u} \rangle$, $\langle \mathbf{f}, \mathbf{u} \rangle$, $\langle \mathbf{u}, \mathbf{t} \rangle$, and $\langle \mathbf{u}, \mathbf{f} \rangle$ as possible values, effectively restricting the set of truth values to $\mathcal{V}_{\mathbf{S}_{\text{fde}}^*}^*$. As this set is closed under the truth functions of AC, this entails that each such v_C is an $\mathbf{S}_{\text{fde}}^*$ valuation. \square

Lemma 7.3.4. *If v is an $\mathbf{S}_{\text{fde}}^*$ valuation then $\mathbf{c}(v)$ is an unsigned, vocabulary closed Correia model.*

Proof. If v is an $\mathbf{S}_{\text{fde}}^*$ valuation then v is a fortiori an AC valuation and $\mathbf{c}(v)$ is by construction vocabulary closed. Now, as for any $p \in \mathbf{At}$ $\text{pr}_0(v(p)) = \mathbf{u}$ iff $\text{pr}_1(v(p)) = \mathbf{u}$, this entails that $\Gamma_{\mathbf{c}(v)}^* = \Delta_{\mathbf{c}(v)}^*$. But this entails that $\mathbf{c}(v)$ is unsigned. \square

Again, Lemma 7.2.1 entails that we may infer the following theorem from Lemmas 7.3.3 and 7.3.4:

Theorem 7.3.2. *The Daniels-Priest logic $\mathbf{S}_{\text{fde}}^*$ is characterized by the class of unsigned and vocabulary closed Correia models.*

Now, let us examine the stronger property corresponding to \mathbf{S}_{fde} .

Definition 7.3.6. *A Correia model \mathbf{v} is relatively complete if for every $p \in \Gamma_{\mathbf{v}}^* \cup \Delta_{\mathbf{v}}^*$, $\langle \{p\}, \{p\} \rangle \in \mathbf{v}$.*

We can make the following observations about relatively complete Correia models.

Lemma 7.3.5. *If \mathbf{v} is relatively complete, then \mathbf{v} is unsigned.*

Proof. Clearly, that a model \mathbf{v} is relatively complete entails that \mathbf{v} is unsigned; if \mathbf{v} is relatively complete, then

$$p \in \Gamma_{\mathbf{v}}^* \text{ iff } \langle \{p\}, \{p\} \rangle \in \mathbf{v} \text{ iff } p \in \Delta_{\mathbf{v}}^*.$$

□

Lemma 7.3.6. *If \mathbf{v} is a relatively complete and vocabulary closed Correia model then for all $v_C \in \mathfrak{F}(\mathbf{v})$, v_C is a bilateral \mathbf{S}_{fde} valuation.*

Proof. Assume \mathbf{v} to be relatively complete and vocabulary closed. By Lemma 7.3.5, \mathbf{v} is also unsigned, whence for any $v_C \in \mathfrak{F}(\mathbf{v})$, the range of v_C is a subset of $\mathcal{V}_{\mathbf{S}_{\text{fde}}}^*$. However, the value $\langle \mathbf{f}, \mathbf{f} \rangle$ is likewise not admissible. As $\langle \{p\}, \{p\} \rangle \in \mathbf{v}$, every $v_C \in \mathfrak{F}(\mathbf{v})$ is such that either $\text{pr}_0(v_C(p)) = \mathbf{t}$ or $\text{pr}_1(v_C(p)) = \mathbf{t}$ whenever $p \in \Gamma_{\mathbf{v}}^* \cup \Delta_{\mathbf{v}}^*$. Hence, the set of truth values to which any atom may be mapped is $\mathcal{V}_{\mathbf{S}_{\text{fde}}}^* \setminus \{\langle \mathbf{f}, \mathbf{f} \rangle\}$. But this is just $\mathcal{V}_{\mathbf{S}_{\text{fde}}}^*$. □

Lemma 7.3.7. *If v is a bilateral \mathbf{S}_{fde} valuation then $\mathbf{c}(v)$ is a relatively complete and vocabulary closed Correia model.*

Proof. If v is a bilateral \mathbf{S}_{fde} valuation, then it is *a fortiori* an $\mathbf{S}_{\text{fde}}^*$ valuation, whence we infer that $\mathbf{c}(v)$ is unsigned and vocabulary closed. Consider an arbitrary $p \in \Gamma_{\mathbf{c}(v)}^* \cup \Delta_{\mathbf{c}(v)}^*$. As v is an \mathbf{S}_{fde} valuation such that neither coordinate of $v(p)$ is \mathbf{u} , either $v(p) \in \mathcal{D}_{\mathbf{S}_{\text{fde}}}^*$ or $v(\dot{\neg} p) \in \mathcal{D}_{\mathbf{S}_{\text{fde}}}^*$. Hence, either $\langle \{p\}, \emptyset \rangle \in \mathbf{c}(v)$ or $\langle \emptyset, \{p\} \rangle \in \mathbf{c}(v)$. But as $\Gamma_{\mathbf{c}(v)}^* = \Delta_{\mathbf{c}(v)}^*$, either option entails that $\langle \{p\}, \{p\} \rangle \in \mathbf{c}(v)$, whence we infer that $\mathbf{c}(v)$ is relatively complete. □

From Lemmas 7.2.1, 7.3.6, and 7.3.7, we infer the following:

Theorem 7.3.3. *The Deutsch-Oller logic \mathbf{S}_{fde} is characterized by the class of relatively complete and vocabulary closed Correia models.*

7.3.3 Non-‘Analytic’ Extensions

There are a number of popular and much-studied deductive systems intermediate between AC and classical logic that fail to enjoy the Proscriptive Principle. In this section, we will characterize three such systems with respect to Correia’s semantics.

Inasmuch as the truth functional semantics for **AC** is intimately related to those for Σ_0 , it is a natural question to ask whether Σ_0 itself can be given Correia semantics. We thus turn to providing properties that in fact correspond to Σ_0 .

Definition 7.3.7. A Correia model \mathbf{v} is consistent if for all $\langle \Gamma, \Delta \rangle, \langle \Gamma', \Delta' \rangle \in \mathfrak{G}(\mathbf{v})$,

$$\Delta \cap \Gamma' = \emptyset.$$

Definition 7.3.8. A vocabulary closed Correia model \mathbf{v} is relatively determinate if \mathbf{v} is consistent and relatively complete.

Lemma 7.3.8. If a vocabulary closed Correia model is relatively determinate then for each $p \in \Gamma_{\mathbf{v}}^* \cup \Delta_{\mathbf{v}}^*$, precisely one of the following holds:

a $\langle \{p\}, \emptyset \rangle \in \mathbf{v}$

b $\langle \emptyset, \{p\} \rangle \in \mathbf{v}$.

Proof. Let \mathbf{v} be vocabulary closed and relatively determinate and consider an arbitrary $p \in \Gamma_{\mathbf{v}}^* \cup \Delta_{\mathbf{v}}^*$. Then by relative completeness, $\langle \{p\}, \{p\} \rangle \in \mathbf{v}$. However, consistency of \mathbf{v} entails that $\langle \{p\}, \{p\} \rangle \notin \mathfrak{G}(\mathbf{v})$. Hence, there must be some $\langle \Gamma, \Delta \rangle \in \mathfrak{G}(\mathbf{v})$ such that $\langle \Gamma, \Delta \rangle \preceq \langle \{p\}, \{p\} \rangle$, and the only Correia pairs that can witness this are $\langle \{p\}, \emptyset \rangle$ and $\langle \emptyset, \{p\} \rangle$. Consistency again prevents both these pairs from simultaneously appearing in $\mathfrak{G}(\mathbf{v})$, whence we conclude that precisely one of these pairs is found in \mathbf{v} . \square

Lemma 7.3.9. If \mathbf{v} is vocabulary closed, unsigned, and relatively determinate, then the range of each $v_C \in \mathfrak{F}(\mathbf{v})$ is a subset of $\{\langle \mathbf{t}, \mathbf{f} \rangle, \langle \mathbf{f}, \mathbf{t} \rangle, \langle \mathbf{u}, \mathbf{u} \rangle\}$.

Proof. Let \mathbf{v} be vocabulary closed, unsigned, and relatively determinate. By definition, \mathbf{v} is also relatively complete, and by Lemma 7.3.6, this entails that each $v_C \in \mathfrak{F}(\mathbf{v})$ is a bilateral \mathcal{S}_{fde} valuation, i.e., maps each atom p to a value of $\mathcal{V}_{\mathcal{S}_{\text{fde}}}^*$. However, that \mathbf{v} is relatively

determinate entails that every such v_C cannot map formulae to the value $\langle \mathbf{t}, \mathbf{t} \rangle$, as for any $C \in \prod(\mathfrak{G}(\mathbf{v})^\tau)$, consistency entails that for no $\langle \Gamma, \Delta \rangle, \langle \Gamma', \Delta' \rangle \in \mathfrak{G}(\mathbf{v})$ will $C(\langle \Gamma, \Delta \rangle^\tau) = C(\langle \Gamma', \Delta' \rangle^\tau)$. Hence, the set of values to which v_C can map an atom p is $\mathcal{V}_{\mathbf{S}_{\text{fde}}}^* \setminus \{\langle \mathbf{t}, \mathbf{t} \rangle\}$. \square

Lemma 7.3.10. *Let v be an $\mathfrak{M}_{\text{AC}} \upharpoonright_{\mathcal{V}_{\Sigma_0}^*}$ valuation. Then $\mathbf{c}(v)$ is an unsigned and relatively determinate vocabulary closed Correia model.*

Proof. As v is trivially an \mathbf{S}_{fde} valuation, we already may infer that $\mathbf{c}(v)$ is unsigned, relatively complete, and vocabulary closed. What remains, then, is to demonstrate that $\mathbf{c}(v)$ is consistent. As $\mathbf{c}(v)$ is unsigned and relatively complete, for every $\langle \Gamma, \Delta \rangle \in \mathfrak{G}(\mathbf{c}(v))$, $\langle \Gamma, \Delta \rangle^\tau$ is a singleton. Hence, the only way that $\mathbf{c}(v)$ could violate consistency would be if both $\langle \{p\}, \emptyset \rangle \in \mathbf{c}(v)$ and $\langle \emptyset, \{p\} \rangle \in \mathbf{c}(v)$. But by Theorem 7.2.2, this would entail that both $v(p) \in \mathcal{D}_{\Sigma_0}^*$ and $v(\neg p) \in \mathcal{D}_{\Sigma_0}^*$, i.e., that $v(p) = \langle \mathbf{t}, \mathbf{t} \rangle$. But $\langle \mathbf{t}, \mathbf{t} \rangle \notin \mathcal{V}_{\Sigma_0}^*$, whence a violation of consistency is seen to be impossible. Hence, $\mathbf{c}(v)$ is unsigned, relatively determinate, and vocabulary closed. \square

As before, Lemmas 7.2.1, 7.3.9, and 7.3.10 yield the following:

Theorem 7.3.4. *The logic Σ_0 is characterized by the class of vocabulary closed Correia models that are unsigned and relatively determinate.*

Proof. Lemmas 7.2.1, 7.3.9, and 7.3.10 jointly entail that the logic characterized by the matrix $\mathfrak{M}_{\text{AC}} \upharpoonright_{\mathcal{V}_{\Sigma_0}^*}$ corresponds to unsigned and relatively determinate Correia models. By Observation 7.2.1, the Bochvar logic Σ_0 is characterized by both \mathfrak{M}_{Σ_0} and $\mathfrak{M}_{\text{AC}} \upharpoonright_{\mathcal{V}_{\Sigma_0}^*}$. Hence, we may conclude that unsigned and relatively determinate Correia models characterize Σ_0 . \square

We've discussed the strong Kleene logic in Section 3.3.1, in which unilateral many-valued semantics were given by Definition 3.3.5.

The first-degree formulation of \mathbf{K}_3 also permits analysis in terms of Correia semantics. To provide this characterization, we first consider an alternative bilateral semantics for \mathbf{K}_3 as a restriction of \mathfrak{M}_{AC} .

Definition 7.3.9. *A bilateral semantics for \mathbf{K}_3 is provided by the matrix $\mathfrak{M}_{\mathbf{K}_3}^* = \mathfrak{M}_{\text{AC}} \upharpoonright_{\mathcal{V}_{\mathbf{K}_3}^*}$, where*

$$\mathcal{V}_{\mathbf{K}_3}^* = \{\langle \mathbf{t}, \mathbf{f} \rangle, \langle \mathbf{f}, \mathbf{t} \rangle, \langle \mathbf{f}, \mathbf{f} \rangle\}.$$

The natural interpretation of the truth values of \mathbf{K}_3 is that the system permits propositions to be *true*, *false*, or *neither true nor false*.

Lemma 7.3.11. *If \mathbf{v} is a consistent and language closed Correia model then for all $v_C \in \mathfrak{F}(\mathbf{v})$, v_C is a \mathbf{K}_3 valuation.*

Proof. Suppose that \mathbf{v} is consistent and language closed. Then $\Gamma_{\mathbf{v}}^* = \Delta_{\mathbf{v}}^* = \mathbf{At}$, whence for each p and $v_C \in \mathfrak{F}(\mathbf{v})$, we can conclude that

- by language closure, both $\text{pr}_0(v_C(p)) \neq \mathbf{u}$ and $\text{pr}_1(v_C(p)) \neq \mathbf{u}$, and
- by consistency, either $\text{pr}_0(v_C(p)) \neq \mathbf{t}$ or $\text{pr}_1(v_C(p)) \neq \mathbf{t}$.

Hence, the set of truth values to which an atom may be mapped by v is $\{\langle \mathbf{t}, \mathbf{f} \rangle, \langle \mathbf{f}, \mathbf{t} \rangle, \langle \mathbf{f}, \mathbf{f} \rangle\}$, *i.e.*, $\mathcal{V}_{\mathbf{K}_3}^*$. As $\mathcal{V}_{\mathbf{K}_3}^*$ is closed under each of the AC truth functions, this entails that for arbitrary formulae A , $v_C(A) \in \mathcal{V}_{\mathbf{K}_3}^*$; in other words, v_C is a \mathbf{K}_3 valuation. \square

Lemma 7.3.12. *If v is a \mathbf{K}_3 valuation, then $\mathbf{c}(v)$ is consistent and language closed.*

Proof. Let v be a \mathbf{K}_3 valuation. As \mathbf{K}_3 is an extension of \mathbf{E}_{fde} , we already understand $\mathbf{c}(v)$ to be language closed. Hence, $\Gamma_{\mathbf{c}(v)}^* = \Delta_{\mathbf{c}(v)}^*$. Consistency of $\mathbf{c}(v)$ may be established by noting that $\langle \mathbf{t}, \mathbf{t} \rangle \notin \mathcal{V}_{\mathbf{K}_3}^*$ and following the steps in Theorem 7.3.4. \square

Lemmas 7.2.1, 7.3.11, and 7.3.12 entitle us to infer the following:

Theorem 7.3.5. *The strong Kleene logic \mathbf{K}_3 is characterized by the class of consistent and language closed Correia models.*

We have already appealed to the dual relationship between \mathbf{K}_3 and Priest's *logic of paradox* LP, presented in Definition 2.3.5, as documented in, *e.g.*, (22). This duality allows us to interpret LP in a bilateral fashion as a restriction of $\mathfrak{M}_{\mathbf{AC}}$. It is thus natural to expect Correia semantics for LP as well.

We begin by defining LP in terms of $\mathfrak{M}_{\mathbf{AC}}$.

Definition 7.3.10. *A bilateral semantics for LP is provided by the matrix $\mathfrak{M}_{\mathbf{LP}}^* = \mathfrak{M}_{\mathbf{AC}} \upharpoonright_{\mathcal{V}_{\mathbf{LP}}^*}$, where*

$$\mathcal{V}_{\mathbf{LP}}^* = \{\langle \mathbf{t}, \mathbf{f} \rangle, \langle \mathbf{f}, \mathbf{t} \rangle, \langle \mathbf{t}, \mathbf{t} \rangle\}.$$

In other words, LP can be interpreted as the restriction of AC induced by demanding that every proposition be either true or false (and perhaps both).

Lemma 7.3.13. *If \mathbf{v} is a relatively complete and language closed Correia model then for all $v_C \in \mathfrak{F}(\mathbf{v})$, v is a bilateral LP valuation.*

Proof. As before, from language closure of \mathbf{v} and completeness relative to \mathbf{At} , we may infer that

- by language closure, both $\text{pr}_0(v_C(p)) \neq \mathbf{u}$ and $\text{pr}_1(v_C(p)) \neq \mathbf{u}$, and
- by completeness relative to \mathbf{At} , either $\text{pr}_0(v_C(p)) = \mathbf{t}$ or $\text{pr}_1(v_C(p)) = \mathbf{t}$

for all $v_C \in \mathfrak{F}(\mathbf{v})$ and $p \in \mathbf{At}$. We are thereby able to infer that v_C must map each atom to $\{\langle \mathbf{t}, \mathbf{f} \rangle, \langle \mathbf{f}, \mathbf{t} \rangle, \langle \mathbf{t}, \mathbf{t} \rangle\}$. But this is $\mathcal{V}_{\mathbf{LP}}^*$ and we may conclude that each $v_C \in \mathfrak{F}(\mathbf{v})$ is a bilateral LP valuation. □

Lemma 7.3.14. *If v is a bilateral LP valuation, then $\mathfrak{c}(v)$ is a relatively complete and language closed Correia model.*

Proof. Let v be an LP valuation. By construction, $\Gamma_{\mathfrak{c}(v)}^* = \Delta_{\mathfrak{c}(v)}^* = \mathbf{At}$, whence we conclude that $\mathfrak{c}(v)$ is language closed. As for all atoms p , either $v(p) \in \mathcal{D}_{\text{LP}}^*$ or $v(\dot{\neg}p) \in \mathcal{D}_{\text{LP}}^*$, either $\langle \{p\}, \emptyset \rangle \in \mathfrak{c}(v)$ or $\langle \emptyset, \{p\} \rangle \in \mathfrak{c}(v)$. But each entails that $\langle \{p\}, \{p\} \rangle \in \mathfrak{c}(v)$. As p was selected arbitrarily, this holds for all atoms, whence $\mathfrak{c}(v)$ is complete relative to \mathbf{At} . \square

Lemmas 7.2.1, 7.3.13, and 7.3.14 secure for us the characterization of LP:

Theorem 7.3.6. *The logic of paradox LP corresponds to the class of relatively complete and language closed Correia models.*

This permits an immediate corollary characterizing the first-degree fragment of the logic RM, *i.e.*, R with the Mingle axiom. We have observed in Definition 3.3.9 that RM_{fde} may be characterized by the union of unilateral LP valuations and \mathbf{K}_3 valuations. This obviously remains true when the LP and \mathbf{K}_3 valuations are treated as restrictions of AC valuations.

Corollary 7.3.1. *The logic RM_{fde} is characterized by the class of language closed Correia models that are either consistent or relatively complete.*

Proof. Immediate from Definition 3.3.9 and Theorems 7.3.5 and 7.3.6. \square

At this stage, we have characterized a number of deductive systems in terms of Correia models. Anticipating the correct characterization of classical logic CL in the next section, we thus arrive at the picture in Figure 7.1.

7.3.4 Correia's Characterization of Classical Logic

We now turn to the question of the characterization of classical logic CL with respect to Correia models. In (49), to yield classical consequence, Correia offers the condition:

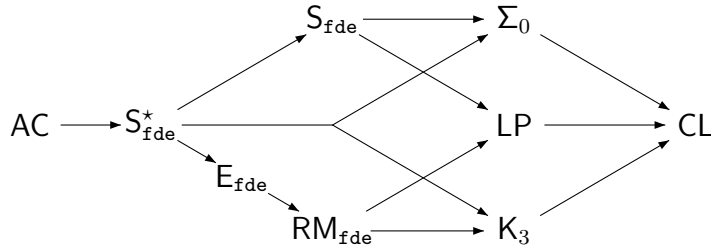

Figure 7.1: First-Degree Systems Intermediate Between AC and CL

Definition 7.3.11 (Condition PC). *For all finite sets of atoms Γ , $\langle \Gamma, \Gamma \rangle \in \mathbf{v}$.*

With this definition, Correia asserts the following:

Assertion 7.3.1 (Correia). *Classical propositional logic is characterized by Correia models enjoying both Conditions TE and PC.*

We will proceed to show that Correia’s position, however, is incorrect. While classical logic is *complete* with respect to such models, it is not *sound*.

Observation 7.3.3. *The conjunction of Conditions TE and PC does not correspond to CL inference.*

Proof. We provide a countermodel. Let \mathbf{w} denote the set

$$\{\langle \{p_0\}, \emptyset \rangle, \langle \emptyset, \{p_0\} \rangle\} \cup \{\langle \{q\}, \{q\} \rangle \mid q \in \mathbf{At}\}.$$

Now consider the Correia model $\llbracket \mathbf{w} \rrbracket$, the vocabulary closure of \mathbf{w} .

By construction, $\llbracket \mathbf{w} \rrbracket$ satisfies Conditions TE and PC. However, although $\emptyset \vDash_{\llbracket \mathbf{w} \rrbracket} p_0 \dot{\wedge} \dot{\neg} p_0$, for no $q \neq p_0$ does $\emptyset \vDash_{\llbracket \mathbf{w} \rrbracket} q$. Hence, $\llbracket \mathbf{w} \rrbracket$ witnesses that $p_0 \dot{\wedge} \dot{\neg} p_0 \rightarrow q$ fails, although this inference is classically valid. \square

In (49), Correia shows that the addition of axiom $A \rightarrow A \dot{\vee} B$ to AC provides an axiomatization of \mathbf{E}_{fde} and that this system is characterized by models satisfying Condition TE. Correia

next demonstrates that the addition of the axiom $A \rightarrow B \dot{\vee} \dot{\wedge} B$ to this axiomatization of \mathbf{E}_{fde} is sufficient to provide an account of classical logic \mathbf{CL} . The fact that the inclusion of $A \rightarrow B \dot{\vee} \dot{\wedge} B$ to his axiomatization of \mathbf{E}_{fde} yields classical logic and the fact that \mathbf{E}_{fde} is sound with respect to models satisfying Condition TE jointly suggest a very natural strategy to approach to the soundness of \mathbf{CL} . To show \mathbf{CL} to be sound with respect to models satisfying Conditions TE and PC, merely prove that $A \rightarrow B \dot{\vee} \dot{\wedge} B$ holds in each model of this class.

The problem with this strategy is subtle. While all theorems of \mathbf{E}_{fde} are valid with respect to models satisfying Conditions TE and PC, the rule of inference \mathbf{AC}_7 —explicitly appearing in the axiomatization of \mathbf{E}_{fde} —fails to hold with respect to this class. As an example, consider a case in which for distinct $p_0, q \in \mathbf{At}$, both $p_0 \dot{\vee} \dot{\wedge} p_0 \rightarrow q \dot{\vee} \dot{\wedge} q$ and $q \dot{\vee} \dot{\wedge} q \rightarrow p_0 \dot{\vee} \dot{\wedge} p_0$ are valid, while $\llbracket \mathbf{w} \rrbracket$ (from Observation 7.3.3) witnesses the failure of $\dot{\wedge}(p_0 \dot{\vee} \dot{\wedge} p_0) \rightarrow \dot{\wedge}(q \dot{\vee} \dot{\wedge} q)$.

Hence, it is in the presence of \mathbf{AC}_7 that the addition of $A \rightarrow B \dot{\vee} \dot{\wedge} B$ to \mathbf{E}_{fde} generates classical logic. Without the validity of \mathbf{AC}_7 , Conditions TE and PC will correspond to a proper subsystem of \mathbf{CL} .

Now, consider the question of which deductive system is in fact characterized by the conjunction of Properties TE and PC.

Lemma 7.3.15. *A language closed Correia model \mathbf{v} enjoys Condition PC iff \mathbf{v} is relatively complete.*

Proof. Let \mathbf{v} be language closed. Then the positive and negative vocabularies of \mathbf{v} are each equal to \mathbf{At} itself. Hence, that \mathbf{v} is relatively complete is equivalent to $\langle \{p\}, \{p\} \rangle \in \mathbf{v}$ for all $p \in \mathbf{At}$. As $\{p\}$ is a finite set of atoms, Condition PC immediately entails relative completeness.

On the other hand, suppose \mathbf{v} to be relatively complete and consider a finite set of atoms Γ such that $q \in \Gamma$. Then by relative completeness, $\langle \{q\}, \{q\} \rangle \in \mathbf{v}$ and by language closure,

$\langle \Gamma, \Gamma \rangle \in \mathbf{v}$. As Γ was selected arbitrarily, \mathbf{v} satisfies Condition PC. \square

Corollary 7.3.2. *The conjunction of Conditions TE and PC characterizes the logic LP.*

This still leaves the question of how to properly characterize classical logic in terms of Correia models.

First, let us examine the counterexample from Observation 7.3.3. Clearly, from a semantical perspective, the responsible element of the counterexample is that in the corresponding set of truth functions $\mathfrak{F}(\llbracket \mathbf{w} \rrbracket)$, each assigns both p_0 and $\neg p_0$ a designated value (as both $\langle \emptyset, \{p_0\} \rangle \in \llbracket \mathbf{w} \rrbracket$ and $\langle \{p_0\}, \emptyset \rangle \in \llbracket \mathbf{w} \rrbracket$) without, *e.g.*, necessitating that q take a designated value.

In order to correctly characterize classical logic, it is essential that we preclude this from obtaining, *i.e.*, we must permit that *one and only one* of $\langle \emptyset, \{p_0\} \rangle$ and $\langle \{p_0\}, \emptyset \rangle$ appear in \mathbf{v} . Recall from Definition 7.3.8 the notion of a Correia model's being *relatively determinate*.

We observe that it is relatively determinate language closed models that correctly characterize classical logic.

Theorem 7.3.7. *Classical logic CL is characterized by the class of language closed models that are relatively determinate, i.e., are determinate relative to \mathbf{At} .*

Proof. If \mathbf{v} is both language closed and relatively determinate then the set of generators $\mathfrak{G}(\mathbf{v})$ contains precisely one of $\langle \{p\}, \emptyset \rangle$ or $\langle \emptyset, \{p\} \rangle$ for each $p \in \mathbf{At}$. Hence, the set $\mathfrak{F}(\mathbf{v})$ contains a single truth function v , the extension of which can be described by the scheme:

$$v(p) = \begin{cases} \langle \mathbf{t}, \mathbf{f} \rangle & \text{if } \langle \emptyset, \{p\} \rangle \in \mathbf{v} \\ \langle \mathbf{f}, \mathbf{t} \rangle & \text{if } \langle \{p\}, \emptyset \rangle \in \mathbf{v} \end{cases}$$

As the bilateral truth values $\langle \mathbf{t}, \mathbf{f} \rangle$ and $\langle \mathbf{f}, \mathbf{t} \rangle$ can be identified with the unilateral values \mathbf{t} and \mathbf{f} , respectively, it can be readily seen that v is essentially a classical valuation on \mathbf{At} .

Hence, there is an isomorphism between the class of relatively determinate, language closed Correia models on the one hand and classical truth functions on the other. By means of Lemma 7.2.1, then, we may confirm the theorem. \square

7.4 Conclusions and Future Research

In (49), Correia suggests two directions in which the study of AC should be taken: the study of extensions of AC in languages with formulae of arbitrary degree (*i.e.*, those in which one permits nested arrows) and the study of the interpretation of his models. The first has been tackled in Chapter 5, in which the similarity between AC and the first-degree fragment of Parry’s PAI was exploited to describe a semantics for a higher degree system of analytic containment in the style of Fine’s semantics of (81). It is hoped that in characterizing a host of systems in terms of Correia’s models, the present inquiry goes some way to addressing the second of Correia’s suggestions.

There are some very obvious questions that remain, *e.g.*, we have in this study focused only on systems that have previously appeared in the literature. However—as Figure 7.1 makes clear—there remain intermediate systems that correspond to classes of Correia models that have not been described here. For example, considering only those vocabulary closed Correia models that are consistent—without demanding that these models be unsigned—would make the axiom $A \dot{\wedge} \dot{\vdash} A \rightarrow B$ valid while permitting counterexamples to the scheme $A \rightarrow A \dot{\vee} \dot{\vdash} A$. To more fully catalog these systems is left for future research.

Of course, the analysis of one problem in formal logic commonly poses as many new questions as those it answers, and the present inquiry is little different. To close, let us consider two further and more difficult directions in which analysis of Correia semantics may be taken.

7.4.1 Extensions of AC^*

The foregoing analysis yields more than just a further semantical account of some many-valued logics. By applying the above characterizations to Correia's analysis of AC^* , these characterizations also suggest a way to enrich classical propositional logic CL with operators corresponding to, *e.g.*, LP entailment.

In (9), Angell describes a system that Correia calls AC^* , considered by both Correia in (49) and (50) and Fine in (87). To define AC^* , we will need to appeal to a richer language. This language \mathcal{L}^* will be defined as follows:

Definition 7.4.1. \mathcal{L}^* is the language defined in Backus-Naur form where $p \in \mathbf{At}$ and $B \in \mathcal{L}_{\mathbf{df}}^{\supset}$:

$$A ::= p|B|\neg A|A \wedge A|A \dot{\vee} A|A \supset A$$

Correia uses $A \leftrightarrow B$ as a shorthand for $(A \rightarrow B) \wedge (B \rightarrow A)$. AC^* may be described syntactically by the following definition:

Definition 7.4.2. The axioms for AC^* are:

- AC_1^* $A \leftrightarrow \neg \neg A$
- AC_2^* $A \rightarrow A \wedge A$
- AC_3^* $A \wedge B \rightarrow A$
- AC_4^* $A \dot{\vee} B \rightarrow B \dot{\vee} A$
- AC_5^* $A \dot{\vee} (B \dot{\vee} C) \leftrightarrow (A \dot{\vee} B) \dot{\vee} C$
- AC_6^* $A \dot{\vee} (B \wedge C) \leftrightarrow (A \dot{\vee} B) \wedge (A \dot{\vee} C)$
- AC_7^* $(A \leftrightarrow B) \supset (\neg A \rightarrow \neg B)$
- AC_8^* $(A \rightarrow B) \supset (A \dot{\vee} C \rightarrow B \dot{\vee} C)$
- AC_9^* $(A \rightarrow B) \supset ((B \rightarrow C) \supset (A \rightarrow C))$
- AC_{10}^* $(A \rightarrow B) \supset (A \supset B)$

AC^* has detachment of the material conditional as its sole rule of inference:

$$AC_{11}^* \quad \text{From } A \text{ and } A \supset B, \text{ infer } B$$

Defining Correia's semantics for AC^* requires a few intermediate definitions.

Definition 7.4.3. *Let v be a classical valuation. Then \tilde{v} is the Correia model defined by the following;*

$$\{\langle \Gamma, \Delta \cup \{p\} \rangle \mid v(p) = \langle \mathbf{t}, \mathbf{f} \rangle \text{ and } \Gamma, \Delta \in \mathbf{Lit}\} \cup \{\langle \Gamma \cup \{p\}, \Delta \rangle \mid v(p) = \langle \mathbf{f}, \mathbf{t} \rangle \text{ and } \Gamma, \Delta \in \mathbf{Lit}\}.$$

It can be established that \tilde{v} is just the Correia counterpart $\mathbf{c}(v)$ as defined in Definition 7.2.4.

Observation 7.4.1. *When v is a classical valuation, $\tilde{v} = \mathbf{c}(v)$.*

Proof. Immediate from the definitions. □

Now, rather than relying on the foregoing account of AC validity, when analyzing AC^* , Correia insists on revising the notion of semantic consequence. Hence, we must introduce a new operator $\Vdash_v \subseteq \mathcal{L}_{\mathbf{zdf}}^{\supset} \times \mathcal{L}_{\mathbf{zdf}}^{\supset}$.

Definition 7.4.4. *Let v be a Correia model. Then we say $A \Vdash_v B$ if for all $\Gamma \in \mathcal{L}_{\mathbf{zdf}}^{\supset}$, the following conditions hold:*

- if $\Gamma \Vdash_v A$ then $\Gamma \Vdash_v B$, and
- $A \Vdash_v \Gamma$ iff $A, B \Vdash_v \Gamma$.

Definition 7.4.5. *An AC^* model is a pair $\langle v, \mathbf{V} \rangle$ where v is a classical valuation and \mathbf{V} is a set of vocabulary closed Correia models such that $\mathbf{c}(v) \in \mathbf{V}$.*

Then truth in a model is given by the definition:

Definition 7.4.6. *If $\langle v, \mathbf{V} \rangle$ is an AC^* model, then truth in the model is defined recursively:*

- $\models_{\langle v, \mathbf{V} \rangle} p$ if $v(p) \in \mathcal{D}_{\text{CL}}$ for $p \in \mathbf{At}$
- $\models_{\langle v, \mathbf{V} \rangle} \neg A$ if $\not\models_{\langle v, \mathbf{V} \rangle} A$
- $\models_{\langle v, \mathbf{V} \rangle} A \dot{\vee} B$ if $\models_{\langle v, \mathbf{V} \rangle} A$ or $\models_{\langle v, \mathbf{V} \rangle} B$
- $\models_{\langle v, \mathbf{V} \rangle} A \rightarrow B$ if for all $\mathbf{v} \in \mathbf{V}$, $A \Vdash_{\mathbf{v}} B$

Clauses for conjunction and material implication can be inferred from the above in the usual fashion.

Inasmuch as AC^* permits us to talk about a species of nonclassical entailment within classical logic, the foregoing inquiry into characterizing such entailment relations with respect to Correia semantics suggests that studying extensions of AC^* could prove useful.

For example, we could proof-theoretically extend Correia's analysis of AC^* to systems such as an analogous LP^* :

Definition 7.4.7. *LP^* is the deductive system generated by AC^* by removing the axiom AC_7^* and adding the axiom*

$$\text{LP}_1^* \quad A \rightarrow B \dot{\vee} \neg B$$

Now, as validity of $A \rightarrow B$ in an AC^* model is a function of the properties of the Correia models in \mathbf{V} , it is natural to expect that one could immediately export the earlier correspondences to likewise characterize, *e.g.*, LP^* .

Curiously, as we will see, this is not the case.

Observation 7.4.2. *LP^* does not correspond to AC^* models $\langle v, \mathbf{V} \rangle$ in which each $\mathbf{v} \in \mathbf{V}$ is relatively complete and language closed.*

Proof. We provide a counterexample. Let \mathbf{x} be the set

$$\{\langle\{p_0\}, \emptyset\rangle\} \cup \{\langle\{q\}, \emptyset\rangle, \langle\emptyset, \{q\}\rangle \mid q \neq p_0\}$$

Then consider $\llbracket \mathbf{x} \rrbracket$ —the language closure of \mathbf{x} . As $p \in \Delta_{\llbracket \mathbf{x} \rrbracket}^*$, because language closure entails that $\llbracket \mathbf{x} \rrbracket$ is unsigned, we may infer that $p \in \Gamma_{\llbracket \mathbf{x} \rrbracket}^*$ as well. By construction, then, $\llbracket \mathbf{x} \rrbracket$ is relatively complete.

Now, we construct the necessary \mathbf{AC}^* model. Let v be a classical valuation; as $\mathbf{c}(v)$ is language closed and relatively determinate, it is also relatively complete. Hence, the \mathbf{AC}^* model $\langle v, \{\mathbf{c}(v), \llbracket \mathbf{x} \rrbracket\} \rangle$ is such that each member of $\{\mathbf{c}(v), \llbracket \mathbf{x} \rrbracket\}$ is language closed and relatively complete.

Now we are able to provide an instance of the axiom \mathbf{LP}_1^* , namely, $p_0 \rightarrow p_1 \dot{\vee} \dot{\neg} p_1$, that fails in $\langle v, \{\mathbf{c}(v), \llbracket \mathbf{x} \rrbracket\} \rangle$. By language closure, we infer that $\langle\{p_1\}, \{p_0, p_1\}\rangle \in \llbracket \mathbf{x} \rrbracket$. Hence, we have the following sequence of inferences:

- $p_1 \vDash_{\llbracket \mathbf{x} \rrbracket} p_0, p_1$
- $\emptyset \vDash_{\llbracket \mathbf{x} \rrbracket} p_0, p_1, \dot{\neg} p_1$
- $\emptyset \vDash_{\llbracket \mathbf{x} \rrbracket} p_0, p_1 \dot{\vee} \dot{\neg} p_1$
- $\dot{\neg} p_0 \vDash_{\llbracket \mathbf{x} \rrbracket} p_1 \dot{\vee} \dot{\neg} p_1$
- $\dot{\neg} p_0, \dot{\neg}(p_1 \dot{\vee} \dot{\neg} p_1) \vDash_{\llbracket \mathbf{x} \rrbracket} \emptyset$

However, we are unable to say that $\dot{\neg} p_0 \vDash_{\llbracket \mathbf{x} \rrbracket} \emptyset$. This would only be derivable from $\emptyset \vDash_{\llbracket \mathbf{x} \rrbracket} p_0$, which would be obtainable only if $\langle\emptyset, \{p_0\}\rangle \in \llbracket \mathbf{x} \rrbracket$. But this Correia pair was omitted by definition.

Thus, $p_0 \Vdash_{\llbracket \mathbf{x} \rrbracket} p_1 \dot{\vee} \dot{\neg} p_1$ fails and we conclude that $\not\vdash_{\langle v, \{\mathbf{c}(v), \llbracket \mathbf{x} \rrbracket\} \rangle} p_0 \rightarrow (p_1 \dot{\vee} \dot{\neg} p_1)$, *i.e.*, \mathbf{LP}_1^* is not valid in such models. \square

As a means of adding a variety of nonclassical entailment operators to classical logic, it will be a worthwhile endeavor to more fully develop extensions of \mathbf{AC}^* . Clearly the solution will

require some further work. It is hoped that the further analysis of such systems can be fully addressed in a future inquiry.

7.4.2 Clauses and Clutters

With respect to a vocabulary closed Correia model \mathbf{v} , it has been an indispensable feature that all information can be recovered from the set of its generators and its positive and negative vocabularies. Moreover, in extensions of \mathbf{E}_{fde} , the set $\mathfrak{G}(\mathbf{v})$ itself suffices. It is worth making a few remarks concerning the structure of $\mathfrak{G}(\mathbf{v})$.

First, clearly the literal projection τ defined in Definition 5.3.12 is a bijection and we may consider $\mathfrak{G}(\mathbf{v})^\tau$ without loss of generality. It is worthwhile to note that objects such as $\mathfrak{G}(\mathbf{v})^\tau$ are in fact quite common in the study of formal logic. A common treatment of formulae in *disjunctive normal form* is to take sets of sets of literals—*i.e.*, subsets of $\wp(\wp(\mathbf{Lit}))$ —as a faithful representation of a proposition and by construction for any \mathbf{v} , $\mathfrak{G}(\mathbf{v})^\tau \subset \wp(\wp(\mathbf{Lit}))$. Hence, structures such as $\mathfrak{G}(\mathbf{v})^\tau$ have appeared frequently in the literature, most notably, in the field of automated theorem proving.

Often, this representation of a proposition or formula is taken as a primitive notion. A disjunction of literals is represented as a *clause*—a set of literals—and a conjunction of such disjunctions is construed as a set of clauses. For example, putting quantifiers aside, the most basic objects—the ‘natural syntactical units’—studied in, *e.g.*, John Alan Robinson’s (164) are sentences considered as finite collection of finite sets of literals.

What seems to underscore the potential interpretative fruits of such a correlation is that containment logics like Angell’s AC have been independently discovered as arising from precisely such structures. The articular models of Ray E. Jennings and Yue Chen were described in (115) as a framework for analyzing entailment faithful to Gottfried Leibniz’s vision of the structure of a proposition. Following remarks of Leibniz, they remark that

[w]e are naturally inclined to interpret the literals as truth-sets, *i.e.*, as members of $\wp(U)$ where U is the universe in a full propositional model. Accordingly the articular representation of a sentence as a set of sets of literals under this interpretation yields a collection of collections of subsets of U , *i.e.*, a *hypergraph* on $\wp(U)$.(115, p. 105)

We will not review the details of the framework of Jennings and Chen but will rest by suggesting a close relationship between the set of generators of a Correia model and the notion of a hypergraph.

Definition 7.4.8. *A hypergraph on a set X is a set of subsets of X , i.e., a set $\mathbb{H} \subseteq \wp(\wp(X))$.*

A simple hypergraph—called a ‘clutter’ in (114)—is a particular type of hypergraph.

Definition 7.4.9. *A simple hypergraph is a hypergraph \mathbb{H} such that for all distinct $E, E' \in \mathbb{H}$, $E \not\subseteq E'$.*

The relationship of Correia semantics and simple hypergraphs is clear:

Observation 7.4.3. *For any Correia model \mathbf{v} , $\langle \mathfrak{G}(\mathbf{v}), \preceq \rangle$ is isomorphic to a simple hypergraph.*

Proof. Every element of the set $\mathfrak{G}(\mathbf{v})$ is clearly incomparable to every other with respect to \preceq . For example, when $\langle \Gamma, \Delta \rangle \in \mathfrak{G}(\mathbf{v})$, if $\langle \Gamma, \Delta \rangle \preceq \langle \Gamma', \Delta' \rangle$, then $\langle \Gamma', \Delta' \rangle \notin \mathfrak{G}(\mathbf{v})$. Hence, each element of $\mathfrak{G}(\mathbf{v})^\tau$ is incomparable to every other with respect to the subset relation. But this is to say that $\mathfrak{G}(\mathbf{v})^\tau$ is a simple hypergraph on **Lit**. \square

AC independently appears (as ‘FDAE’ for ‘first-degree analytic entailment’ in (115)) as a consequence relation arising from valuations that map literals to simple hypergraphs. This reinforces the speculation that light may be shed on the interpretation of Correia models by considering work on analyzing propositions as sets of clauses or simple hypergraphs.

Beyond the matter of interpretation, though, examining the connection between Correia's semantics and these areas of research may also assist in obtaining further formal results. Articular models are capable of capturing deductive behavior weaker than AC. Correia's models, for all their apparent idiosyncrasies, do in fact expose a limitation of presentation of AC in Definition 5.2.3, that is, that the truth functional semantics does not immediately suggest a means of modeling systems *weaker* than AC. There exist systems weaker than AC—such as the first-degree fragment of Sören Halldén's *S0*—that lack sufficient semantic analyses¹ and, as Correia demonstrates, Correia models without the requirement of vocabulary closure also correspond to a proper subsystem of AC. Hence, to investigate the proximity of Correia's models to such semantical frameworks may yield accounts of first-degree deductive systems that resist a natural analysis in the many-valued framework.

¹While *S0* (and hence *S0_{fde}*) has a semantic analysis due to Sylvan and Meyer in (167), the semantics is exceedingly artificial, as the authors freely concede.

Chapter 8

Concluding Remarks

What have we accomplished by surveying a variety of occasions—linguistic, metaphysical, computational—in which Parry’s Proscriptive Principle can be given an intuitive reading?

If anything has been accomplished, I hope that what has been shown is that systems whose behavior more or less respects Parry’s criterion are not limited by their failure to perfectly capture the notion of Kantian analyticity. Rather, we are afforded a much broader range of interpretations than Parry’s critics—*or* his sympathizers, for that matter—had previously allowed. We have surveyed numerous contexts in which this type of behavior arises: We have observed that many approaches to the linguistic notion of meaninglessness or nonsense lead to behavior very similar to the Proscriptive Principle, for example. In metaphysics, we discussed how the Parry systems of Angell’s **AC** and Correia’s **Cor** arise in Fine’s state space semantics and how this analysis can be applied to resolve some puzzling features of Restall’s truthmaker semantics. That we have examined such systems in the settings of bilattices, dynamic logic, and constructive logic suggests that researchers in artificial intelligence or the philosophy of mathematics may themselves benefit from the utility of Parry’s intuitions. And by considering catastrophic errors in computation—when a program hangs or is unable to retrieve a value—we provided semantics for several of these systems in terms

of programs.

Most of the foregoing chapters have included suggestions for future research, in which we have identified a number of investigations regrettably set aside, *e.g.*, looking into Halldén’s S_0 , developing a theory of Parry systems on logical multilattices in general, providing axiomatizations of the intensional containment logics included in Deutsch’s S . As we close, however, I would like consider future directions with a broader brush, by describing several of the limitations of this dissertation and the directions in which this work may be taken.

8.1 Refining the Notion of Content

Much of the criticism leveled against Parry’s PAI is tacitly related to the fact that the notion of content it assumes is relatively coarse-grained. In the context of Parry-type systems, we have refined this notion to some degree by the introduction of *positive* and *negative* content, but further refinements can be made. (81) contains a number of suggestions concerning how the notion of *content* or *subject-matter* can be given a more fine-grained analysis.

8.1.1 The Content of Entailments

For one, the *syncategoramatic* terms—*i.e.*, the connectives—have played no role in determining the content of a complex formula in this dissertation. Providing a more subtle reading to the connectives that takes into account the contribution of such syncategoramatic elements to a proposition’s overall content is a project that has been suggested by Fine in (81) but has not yet received an adequate investigation.

With respect to the *extensional* connectives, it is unclear that one should place too heavy an emphasis on their contribution. Undoubtedly, between an atom p and the conjunction $p \wedge p$, the latter ‘contains’ the concept of conjunction in a way that the former lacks. Despite this, when we go so far as to suggest that the propositions $p \dot{\vee} p$ and $p \dot{\wedge} p$ express

incommensurate propositions—the incommensurability between which is understood as an undesirable feature of Suszko and Bloom’s SCI of (29) and (30)—it seems that the notion of content becomes so fine-grained as to be indistinguishable from syntax. (And indeed, Suszko and Bloom’s basic SCI treats even $p \dot{\vee} q$ and $q \dot{\vee} p$ as corresponding to wholly distinct propositions.) To allow this much weight to syncategorematic terms is to lurch too far in this direction.

Despite this, the contribution that the notion of *entailment* makes to the content of a proposition in which it appears seems distinct from the contribution of the truth-functional connectives. On its face, it seems far fetched to suggest that the content of *extensional* claims about the world—conjunctions and disjunctions of simple atomic statements—includes the concept of intensional entailment. This intuition bears some resemblance to the classical is/ought problem: The assertion that some entailment or other is valid is, in a strong sense, as *normative* a claim as any of Hume’s ‘oughts,’ and the assertion that $A \rightarrow B$ just as clearly ‘expresses some new relation or affirmation’ (108, p. 469) not discoverable in mere extensional facts.

This intuition is reflected in the *Ackermann property*—and its converse—common to many relevant logics. This property—first shown to hold of Wilhelm Ackerman’s Π in (3) and (4)—is the criterion that every valid entailment of the form $A \rightarrow (B \rightarrow C)$ is such that the symbol ‘ \rightarrow ’ appears in A (or a *falsum* constant \perp). When taken up by Anderson and Belnap, the Ackermann property and its converse become something of a motto:

Entailments are *sui generis* in the following sense: only entailments entail entailments... Moreover, it is never the case that the *denial* of an entailment entails an entailment.[p. 718](5)

Parry actually identifies this criterion as a ‘proscriptive principle,’ although he is skeptical of its validity:

This... anticipates the later doubt about [the axiom $f(p) \rightarrow (p \rightarrow p)$] stimulated by the (proscriptive) principle of Ackermann and Anderson-Belnap, that only entailments entail entailments. But it still seems to me that in any case a *non-entailment* may entail an entailment. (148, p. 105)

Parry's skepticism notwithstanding, the interpretation of the Ackermann property and its converse as a thesis about analytic implication enjoys quite a bit of plausibility. The development of modifications to PAI in which this Humean-style criterion is taken into account is worthy of exploration.

A further wrinkle in considering the content of formulae including entailments appears when we make the move to *positive* and *negative* subject-matter or content. For example, when considering the conditional as a primitive, the syntax of a conditional $A \rightarrow B$ strongly suggests that the formulae A and B are employed in a 'positive' sense in the formula. This is especially clear in the Hempel case—*i.e.*, the sentence 'all ravens are black'—in which the default position seems to be that one is talking—positively—about *ravens* and *blackness*, rather than *non-ravens* and *non-blackness*. This default position was reflected in Definition 5.4.1, in which models for the Parry-like PAC described the *positive content* of a conditional $A \rightarrow B$ as the union of the positive content of A and the positive content of B .

In Definition 5.4.1 we described the *negative content* of $A \rightarrow B$ in an analogous fashion—as the union of the negative contents of both A and B . But this, I suspect, parts ways with the polarities of one's assertions when one *denies* a conditional. To *deny* $A \rightarrow B$ on many readings—such as Nelson's in (135)—is to suggest a *counterexample* in which A is true and B is false. The Nelsonian identification of $\neg(A \rightarrow B)$ and $A \wedge \neg B$ —*i.e.*, that the two have identical *meanings*—entails that the two have identical *content*, suggesting that the valence of A remains positive in the *negative content* of $A \rightarrow B$. To revise Definition 5.4.1 to incorporate this assertion in the content functions γ^+ and γ^- might appear as follows:

- $\gamma^+(A \rightarrow B) = \gamma^+(A) \cup \gamma^+(B)$
- $\gamma^-(A \rightarrow B) = \gamma^+(A) \cup \gamma^-(B)$

Such a definition appears to be entirely natural. Axiomatizing not only PAC but also its cousin determined by this alternative, Nelsonian account of the positive and negative content of an entailment is a compelling next step to take.

8.1.2 Quantification

One of the upshots of the present interpretations of first-degree, propositional Parry systems is that they provide new frameworks within which to examine the various notions in conceptivist systems. One such notion that has been thus far ill-understood in conceptivist systems is quantification and predicate extensions. In general, quantificational extensions of Parry systems have been guided by inchoate notions of ‘concepts’ and ‘content.’ Being guided by concepts from the realms of computation and linguistics has the benefit of casting such concepts in a different light.

Many of the motivating themes that we have invoked are implicitly about a first-order framework. For example, many of the motivations for the development of logics of nonsense explicitly invoked the application of predicates to objects, *e.g.*, the notion of a ‘category mistake’ presupposes such a framework. While the propositional languages we have considered are capable of modeling theses concerning, *e.g.*, meaningless statements or retrieving values for sentences, they are insufficiently expressive to represent the problematic cases themselves.

There have been a number of attempts to develop a quantification theory for conceptivist systems. For example, in (81), Fine briefly considers the matter of how to carry over Parry’s intuitions from the propositional case to the first order case and, as mentioned, Daniels’ story semantics of (54) and Loftson’s discussion in (129) and (130) provide quantification theories that are by and large harmonious with Parry’s intuitions.

Especially salient is the question of whether the content of a universal sentence $\forall xA$ contains the content of each of its substitution instances $A(x := a)$. From the perspective of (54), it seems clear that a universal formula should not be thought of as containing all ‘names’; the appearance of the line ‘Everyone was an accomplice’ (and, therefore, the tacit endorsement of its truth) in a Sherlock Holmes tale should not entail that ‘Flash Gordon was an accomplice,’ as this runs afoul of the prohibition against introducing ‘new and unwanted names.’¹ Fine himself provides a similar argument from our apparent ability to grasp universal sentences, observing that ‘in order to understand $\forall xA(x)$ I need not know (or, at least possess names for) the objects in the domain of the quantifier.’ (81, p. 178) Fine gestures towards some ways of looking at the content of a first order sentence in terms of his semilattices of concepts, but he arrives at nothing definitive.

Furthermore, the interpretation of such systems in terms of computation might also yield a natural way of extending the picture to quantified formulae. Seating the discussion in terms of computation allows us to look at the question in a different light.

Rather than being forced into the question of whether the content of a universal sentence contains all names, it may be fruitful to instead think of a formula $\forall xA$ as being evaluated by a routine for each name in the environment in parallel. Hence, if the algorithm does not halt on evaluating $\forall xA$ —and assigns it a value of 1—then for any name a recognized by the environment, the algorithm evaluating $A(x := a)$ can be run. Whether to accept or to reject the inference $\forall xA \vDash A(x := a)$ if a function of whether one allows names not recognized by the environment.

Likewise, considering the inference $A(a) \vDash \exists x(x := a)$ becomes rather straightforward, if only we interpret $\exists xA$ as being evaluated by a routine that runs on all names a and asks

¹This description of the prohibition does not necessarily presuppose cases in which, *e.g.*, all elements of some domain are assigned names (or constants). Even if the *name* ‘Flash Gordon’ is not, *e.g.*, expressible within the bounds of a Sherlock Holmes story, Daniels’ position equally suggests that the *proposition* that Flash Gordon was an accomplice is not part of the proposition expressed by the sentence ‘Everyone was an accomplice.’

whether $A(x := a)$ is true. If we take names to be governed by the environment, then the fact that $A(x := a)$ can be successfully evaluated says nothing concerning whether a routine evaluating $A(x := b)$ will terminate.

In each case, the present approach may allow us to export the duties performed by the machinery of Fine's semilattices of concepts to valuation functions themselves. The first-degree conceptivist systems described in Section 4.3.3 secure the Proscriptive Principle without such a semantical apparatus; whether this can be extended to first order or higher degree systems remains to be seen. Thoroughly applying the interpretations covered in this dissertation to higher degree and first order systems is a matter for another day. Yet it seems apparent that such approaches would recast the analysis of these formal matters and might allow for a more intuitive way to extend conceptivist intuitions to these cases.

8.2 Related Deductive Calculi

Over the course of the foregoing material, we have succeeded in drawing together a number of *a priori* disparate approaches to deduction. Much work still remains, however. There are two families of deductive systems that we have largely ignored that deserve to be identified as natural targets for further study: For one, there exist systems that are *dual* to Parry logics in that their respective accounts of entailment require that content be *introduced to*—rather than the *decomposed from*—that of the antecedent. Secondly, the constellation of extensions to and subsystems of Parry's PAI is far from mapped out.

8.2.1 Dual Systems

If it is tempting to read Parry's Proscriptive Principle as the requirement that entailments be *analytic*—so that the concepts of the consequent already appear in those of the antecedent—then it seems just as natural to consider whether an analogous principle might correspond

to something resembling Kantian *ampliativity*.

Now, such a property dual to Parry's Proscriptive Principle has appeared as the 'converse Parry property' by Kosta Došen in (63) or as a property of 'dual dependence' by Epstein in (71), according to which for any valid entailment $A \rightarrow B$ all atoms appearing in A also appear in B .

Of course, if the legitimacy of Parry's logic as a correct exegesis of Kantian *analytic* reasoning is strained, then the suitability of this *dual* property as capturing *ampliative* reasoning seems even more problematic. But we aren't beholden to a Kantian reading of this dual property, either; one of the upshots of the foregoing chapters has been the availability of many alternative readings of Parry's criterion.

Such readings are available to converse Parry systems as well. In (70), Richard Epstein remarks that his system DualD—effectively the dual system to the Dunn-Epstein system DAI—was interpreted by Douglas Walton as a 'logic of actions' in (191). On Walton's interpretation, the validity of an entailment corresponds to the successful application of an action in bringing about new information. One obvious problem is to provide analyses that similarly act as dual, 'ampliative' counterparts to the systems in the neighborhood of PAI. While Fine's semantics can be adjusted without difficulty to allow only ampliative entailments, much work remains, *e.g.*, examining axiomatizations of these dual systems and describing their properties.

Moreover, it seems that the techniques in this dissertation can be directly applied to provide interpretations for systems like DualD. For example, Chapters 2 and 5 relied heavily on the status of the Bochvar-Kleene nonsense logic Σ_0 as 'almost Parry.' Not surprisingly, Halldén's C_0 , too, can be understood in similar terms and given an analogous characterization in terms of classical validity and the containment of atoms. The feature that is cognate with the failure of Addition in Σ_0 , for example, is the failure of Conjunctive Simplification, *i.e.*, the inference from $A \wedge B$ to A . Most prominently, Roberto Ciuni in (44) and Ciuni

and Massimiliano Carrara in (45) have considered interpretations and characterizations of C_0 (referred to as ‘PWK’ for ‘paraconsistent weak Kleene’) that are harmonious with the foregoing interpretation of Σ_0 .

That such an analysis can induce converse Parry systems in the first-degree case has been confirmed by Damian Szmuc. In (187), Szmuc dualizes the techniques found in Chapter 6 to provide bilattice semantics for ‘track-down’ operations that give rise to the deductive calculi FDE_{PWK} and dAC , which are dual to S_{fde} (called ‘ FDE_{WK} ’ by Szmuc) and AC , respectively. In this setting, Fitting’s epistemic interpretation of cut-down operations on bilattices from (91) immediately yields epistemic interpretations of ‘track-down’ operations and, in turn, intensional interpretations of these converse Parry calculi.

8.2.2 Other Parry Systems

The literature contains a wider family of Parry logics than has been acknowledged in this dissertation. Some of these systems were introduced with Parry’s PAI in mind and others have been described wholly independently of Parry’s enterprise. While we have *acknowledged* a number of these systems in the foregoing pages, many have been relegated to footnotes and many systems have not been rigorously considered *qua* Parry logics. A full picture of containment logic, of course, would require that these systems—outlined in Figure 8.1—be given an analogous treatment and, because a full picture is ultimately desirable, we might consider some of the regrettable omissions in outline.

First to be mentioned is the lack of sufficient analyses for the three subsystems of PAI appearing in Figure 8.1.

Most conspicuous of the omitted subsystems is the lack of a semantical analysis of Parry’s original system AI of (143). Recall that Fine’s (81) analyzes a proper extension by including the axiom $(A \dot{\wedge} \dot{\neg} B) \rightarrow \dot{\neg}(A \rightarrow B)$. Because Parry claimed that he had endorsed this axiom as far back as 1957 and ultimately endorsed Fine’s semantics as harmonious with

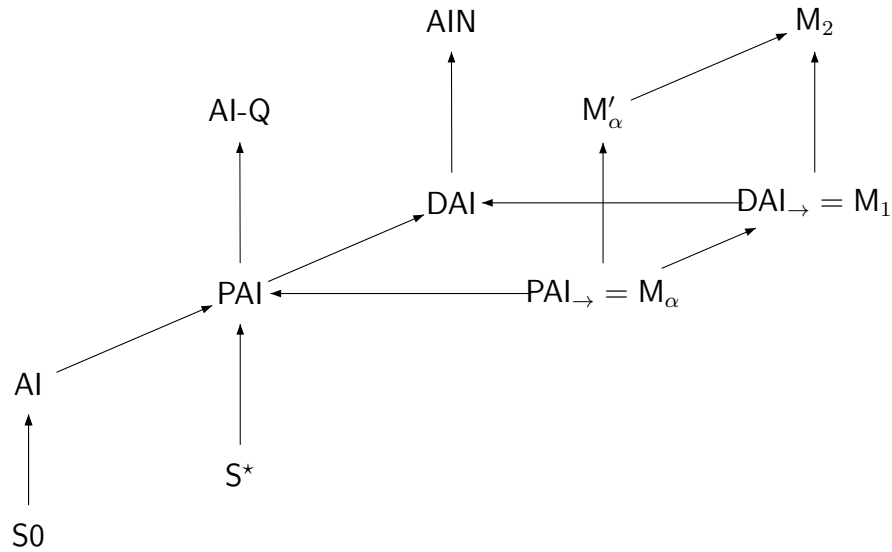

Figure 8.1: Deductive Systems in the Neighborhood of PAI

his intuitions, the discovery of a semantics for AI would presumably have little worth as a guide to Parry’s philosophy. As a formal matter, however, the lack of a semantics for AI is a regrettable deficiency of this dissertation and it is worth investigating whether AI can be given a Fine-style analysis by making subtle changes to Fine’s analysis.

A further deficiency is the lack of a Fine-style analysis of Daniels’ logic S^* . The first-degree fragment of the system has made many appearances over the course of this dissertation and the intensional system—as Daniels notes—enjoys the Proscriptive Principle. Indeed, by a brief inspection of the axiomatization found in (54), it can be confirmed that each theorem of the system is a theorem of PAI. Now, the ‘story semantics’ Daniels provides in (54) bears little resemblance to the Fine-style analysis of PAI, but it seems plausible that a correspondence between the two frameworks can be provided. Due to the similarity between Daniels’ remarks on implication and content and the foregoing Observation 5.4.3, my own suspicion is that S^* is the system $PFDE_{\varphi}$ defined semantically in Definition 5.4.4. The task of generating a

correspondence governing the relationship between S^* and $PFDE_\varphi$ —or at least an analysis thereof—is unfortunately still outstanding but is well worth picking up in the future.

The final subsystem that has been set aside is Halldén’s system **S0** described in (103). **S0** is historically notable as—arguably—the first paraconsistent system introduced, appearing in the same year as Jaśkowski’s (112). But in introducing **S0**, Halldén was not trying to codify any freestanding intuitions concerning entailment, but rather he intended to make a formal observation concerning Lewis’ logic of strict implication **S1**. In **S1**, the strict implication connective is not primitive, but is defined in terms of \diamond , so that

$$\varphi \rightarrow \psi =_{df} \neg \diamond (\varphi \wedge \neg \psi)$$

appears in its axiomatization. **S0** is defined as the deductive system determined by omitting this definition from the rules and axioms of **S1**. What Halldén shows is that by taking the implication connective as primitive and eliminating this definition, even if all the axioms of **S1** governing the behavior of the connective are retained, the resulting logic is quite different than **S1**.

S0 seems to have been nearly forgotten until being resurrected by Parry in (145)—which appears in full as (146)—in which Parry observes that the system **S0** is properly contained in **A1**. Hence, **S0** is a \rightarrow -Parry system and it would be desirable to analyze the system *qua* containment logic.

While Sylvan and Meyer provided a semantical analysis of **S0** in (167), the framework they provide is intended to provide a semantics for *every* axiomatic deductive calculus. Hence, Sylvan and Meyer’s semantics for **S0** is not motivated by any set of features particular to **S0**. Whether Halldén’s system can be given an analysis in line with Fine’s (81) is an interesting question and one worth pursuing. It seems likely, for example, by adapting the content semilattices to the case of Cresswell’s neighborhood semantics for **S1** in (52) might provide an appropriate account of **S0**.

The dissertation has also stopped short of analyzing two *extensions* of PAI in which the language is enriched by the addition of a unary necessity operator. Both systems—Loptson’s AI-Q from (130) and Urquhart’s AIN from (188)—are interesting in their own rights from both philosophical and formal perspectives and deserve to be reexamined in the future.

Loptson’s AI-Q, introduced in (130), enriches PAI by adding a modal operator whose behavior is modeled after Arthur Prior’s modal logic Q. AI-Q is interesting as its introduction is accompanied by a very detailed and reasonable philosophical argument for its legitimacy, some of which was mentioned in Chapter 3. Although the question of whether an analysis can be given along the lines of Fine’s analysis of PAI is a compelling one—and should, I think, be taken up—Loptson’s (130) provides an axiom system for AI-Q and describes a semantics with respect to which the axiom system is sound. Completeness with respect to Loptson’s semantics is not demonstrated, however, so there remain open questions about the system independent of this dissertation.

Urquhart was one of the three philosophers to contemporarily take up Parry’s system anew in the 1970s and 1980s, joining Dunn’s (65) and Fine’s (81) with his own system AIN in (188). While AI-Q adds to PAI a modality like that of Q, Urquhart enriches the *demodalized* DAI with a modality corresponding to S4.

Especially interesting is a conjecture that Urquhart makes in the concluding remarks of (188). Motivated by the Gödel-McKinsey-Tarski-style embeddings of intuitionistic logic into S4 found in (100) and (133), Urquhart conjectures that a similar translation (\Box) allows the embedding of PAI into AI. More informally, the conjecture states that A is provable in PAI if and only if A^\Box is provable in AIN. To the best of my knowledge, this conjecture has been neither proven nor refuted, and investigating Urquhart’s conjecture further appears to be a worthwhile pursuit.

In contrast to AI-Q and AIN, which *enrich* the language of PAI, we have also neglected to discuss a family of *implicational* systems in the language \mathcal{L}_\rightarrow . In (138), Marek Nowak studies

the implicational fragments PAI_{\rightarrow} and DAI_{\rightarrow} —calling them ‘ M_{α} ’ and ‘ M_1 ,’ respectively—and two extensions to these systems. The extensions themselves— M'_{α} and M_2 —are not terribly interesting as sets of theorems. The theorems of the respective systems correspond to the set of **S4** and **S5** validities that meet Parry’s criterion (what would be called ‘**S4_{PP}**’ and ‘**S5_{PP}**’ in the language of Chapter 2) and therefore are subject to Sylvan’s criticism of a ‘double-barrelled analysis’ in the worst way. Nevertheless, Nowak’s axiomatizations are intriguing—it is admittedly not obvious how one could provide a Hilbert-style account of M'_{α} and M_2 —and studying Nowak’s axiom systems in more detail may well prove instructive.

8.3 Conclusion

Clearly, the work initiated by Parry in (143) is still far from finished. We leave unexplored myriad avenues—avenues of both philosophical and formal interest—that lead from Parry’s own work to frontiers not imagined by Parry.

It is painfully obvious, when the limitations of this dissertation are surveyed, that the foregoing material makes little more than a dent in exploring the themes of Parry’s work. But I think that, at the very least, I have succeeded in demonstrating that those who have decried Parry’s work as nothing more than syntactical gimmickry were premature in their assessment. We have surveyed a very wide range of occasions in which Parry’s intuitions are relevant and the breadth of these applications reinforces a suspicion that the study of Parry’s work proves to be a rewarding exercise.

It is my hope that the thoughts contained in this dissertation—however meandering they may have been—succeed in kindling a new interest in Parry and his techniques, and that the work left unfinished in the foregoing pages will be pursued.

Bibliography

- [1] Åqvist, L. (1962). Reflections on the logic of nonsense. *Theoria*, 28(2):138–157.
- [2] Abelson, H., Sussman, G. J., and Sussman, J. (1996). *Structure and Interpretation of Computer Programs*. The MIT Press, Cambridge, MA, second edition.
- [3] Ackermann, W. (1956). Begründung einer strenger Implikation. *Journal of Symbolic Logic*, 21(2):113–128.
- [4] Ackermann, W. (1958). Über die Beziehung zwischen strikter und strenger Implikation. *Dialectica*, 12(3–4):213–222.
- [5] Anderson, A. R. and Belnap, Jr., N. D. (1961). Enthymemes. *The Journal of Philosophy*, 58(23):713–723.
- [6] Anderson, A. R. and Belnap, Jr., N. D. (1962). Tautological entailments. *Philosophical Studies*, 13(1–2):9–24.
- [7] Anderson, A. R., Belnap, Jr., N. D., Dunn, J. M., and Meyer, R. K. (1975). *Entailment: The Logic of Relevance and Necessity*, volume I. Princeton University Press, Princeton.
- [8] Angell, R. B. (1962). A propositional logic with subjunctive conditionals. *Journal of Symbolic Logic*, 27(3):327–343.
- [9] Angell, R. B. (1977). Three systems of first degree entailment. *Journal of Symbolic Logic*, 42(1):147.
- [10] Angell, R. B. (1981). Analytic truth-tables. *Journal of Symbolic Logic*, 46(3):677.
- [11] Angell, R. B. (1989). Deducibility, entailment and analytic containment. In Norman, J. and Sylvan, R., editors, *Directions in Relevant Logic, Reason and Argument*, pages 119–143. Kluwer Academic Publishers, Boston, MA.
- [12] Arieli, O. and Avron, A. (1994). Logical lattices and inconsistent data. In *Proc. 9th Annual IEEE Symposium on Logic in Computer Science*, pages 468–476, Los Alamitos, CA. IEEE Computer Society.

- [13] Arieli, O. and Avron, A. (1996). Reasoning with logical bilattices. *Journal of Logic, Language, and Information*, 5(1):25–63.
- [14] Arieli, O. and Avron, A. (1998). The logical role of the four-valued bilattice. In *Proc. 30th Annual IEEE Symposium on Logic in Computer Science*, pages 118–126, Los Alamitos, CA. IEEE Computer Society.
- [15] Aristotle (1938). *The Categories, On Interpretation, and Prior Analytics*. William Heinemann, Ltd., London. Translated by H. P. Cook and H. Tredennick.
- [16] Armstrong, D. M. (1989). *A Combinatorial Theory of Possibility*. Cambridge Studies in Philosophy. Cambridge University Press, New York.
- [17] Armstrong, D. M. (2004). *Truth and Truthmakers*. Cambridge Studies in Philosophy. Cambridge University Press, New York.
- [18] Avron, A. and Konikowska, B. (2009). Proof systems for reasoning about computation errors. *Studia Logica*, 91(2):273–293.
- [19] Ayer, A. J., editor (1959). *Logical Positivism*. The Free Press, New York.
- [20] Barwise, J. and Perry, J. (1981). Semantic innocence and uncompromising situations. *Midwest Studies in Philosophy*, 6(1):387–404.
- [21] Barwise, J. and Perry, J. (1983). *Situations and Attitudes*. MIT Press, Cambridge, MA.
- [22] Beall, J. C. (2011). Multiple-conclusion LP and default classicality. *Review of Symbolic Logic*, 4(2):326–336.
- [23] Belnap, Jr., N. D. (1977a). How a computer should think. In Ryle, G., editor, *Contemporary Aspects of Philosophy*, pages 30–56. Oriel Press, Stockfield.
- [24] Belnap, Jr., N. D. (1977b). A useful four-valued logic. In Dunn, J. M. and Epstein, G., editors, *Modern Uses of Multiple-valued Logic*, pages 8–37. Reidel, Dordrecht.
- [25] Belnap, Jr., N. D. (1989). Conjunctive containment. In Norman, J. and Sylvan, R., editors, *Directions in Relevant Logic, Reason and Argument*, pages 145–156. Kluwer Academic Publishers, Boston, MA.
- [26] Bigelow, J. (1988). *The Reality of Numbers*. Oxford University Press, Oxford.
- [27] Bilat, A. (2015a). Non-Fregean logics of analytic equivalence I. *Bulletin of the Section of Logic*, 44(1–2):53–68.
- [28] Bilat, A. (2015b). Non-Fregean logics of analytic equivalence II. *Bulletin of the Section of Logic*, 44(1–2):69–80.

- [29] Bloom, S. L. and Suszko, R. (1971). Semantics for the sentential calculus with identity. *Studia Logica*, 28:77–81.
- [30] Bloom, S. L. and Suszko, R. (1972). Investigations into the sentential calculus with identity. *Notre Dame Journal of Formal Logic*, 13(3):289–308.
- [31] Bochvar, D. A. (1938). On a three-valued logical calculus and its application to the analysis of contradictions. *Matematicheskii Sbornik*, 4(2):287–308.
- [32] Bochvar, D. A. (1981). On a three-valued logical calculus and its application to the analysis of the paradoxes of the classical extended functional calculus. *History and Philosophy of Logic*, 2(1–2):87–112. Translated by M. Bergmann.
- [33] Bolc, L. and Borowik, P. (1992). *Many-Valued Logics*. Springer, New York.
- [34] Brady, R. T. (1984). Depth relevance of some paraconsistent logics. *Studia Logica*, 43(1):63–73.
- [35] Brady, R. T. (1988). A content semantics for quantified relevant logics. I. *Studia Logica*, 47(2):111–127.
- [36] Brady, R. T. (1996). Relevant implication and the case for a weaker logic. *Journal of Philosophical Logic*, 25(2):151–183.
- [37] Brady, R. T. (2006). *Universal Logic*. CSLI Publications, Stanford.
- [38] Brady, R. T. and Routley, R. (1973). Don't care was made to care. *The Australian Journal of Philosophy*, 51(3):211–225.
- [39] Carnap, R. (1931). Überwindung der metaphysik durch logische analyse der sprache. *Erkenntnis*, 2(1):219–241. Reprinted in [19]:60–81.
- [40] Carnap, R. (1935). *The Logical Syntax of Language*. Kegan Paul, Trench, Trubner and Company, London.
- [41] Carnielli, W. and Coniglio, M. (2014). Swap structures for LFIs. *CLE e-Prints*, 14(1):1–42.
- [42] Carnielli, W., Coniglio, M. E., and Marcos, J. (2007). Logics of formal inconsistency. In Gabbay, D. and Guenther, F., editors, *Handbook of Philosophical Logic*, volume 14, pages 15–107. Springer, Netherlands.
- [43] Carnielli, W., Marcos, J., and de Amo, S. (2000). Formal inconsistency and evolutionary databases. *Logic and Logical Philosophy*, 8:115–152.
- [44] Ciuni, R. (2015). Conjunction in paraconsistent weak Kleene logic. In Arazim, P. and Dank, M., editors, *The Logica Yearbook 2014*, pages 61–76. College Publications, London.

- [45] Ciuni, R. and Carrara, M. (2016). Characterizing logical consequence in paraconsistent weak Kleene logic. In Feline, L., Paoli, F., and Rossanese, E., editors, *New Developments in Logic and the Philosophy of Science*. College Publications, London.
- [46] Cohen, P. J. (1963). The independence of the continuum hypothesis, I. *Proceedings of the National Academy of Sciences of the United States of America*, 50(6):1143–1148.
- [47] Cohen, P. J. (1964). The independence of the continuum hypothesis, II. *Proceedings of the National Academy of Sciences of the United States of America*, 51(1):105–110.
- [48] Coniglio, M. and Corbalán, M. I. (2013). Sequent calculi for the classical fragment of Bochvar and Halldén’s nonsense logics. In Kesner, D. and Viana, P., editors, *Proc. 7th Workshop on Logical and Semantic Frameworks, with Applications (LSFA 2012)*, volume 113 of *Electronic Proceedings in Theoretical Computer Science*, pages 125–136.
- [49] Correia, F. (2004). Semantics for analytic containment. *Studia Logica*, 77(1):87–104.
- [50] Correia, F. (2010). Grounding and truth functions. *Logique et Analyse*, 53(211):251–279.
- [51] Correia, F. (2016). On the logic of factual equivalence. *Review of Symbolic Logic*, 9(1):103–122.
- [52] Cresswell, M. J. (1995). S1 is not so simple. In *Modality, Morality, and Belief: Essays in Honor of Ruth Barcan Marcus*, pages 29–40. Cambridge University Press, New York.
- [53] Damásio, C. V. and Pereira, L. M. (1995). A model theory for paraconsistent logic programming. In Pinto-Ferreira, C. and Mamede, N. J., editors, *Progress in Artificial Intelligence*, volume 990, pages 377–386. Springer.
- [54] Daniels, C. (1986). A story semantics for implication. *Notre Dame Journal of Formal Logic*, 27(2):221–246.
- [55] Daniels, C. (1990a). A note on negation. *Erkenntnis*, 32(3):423–429.
- [56] Daniels, C. (1990b). The propositional objects of mental attitudes. *Journal of Philosophical Logic*, 19(3):317–342.
- [57] Dawson, E. (1968). Review: Lennart Åqvist, *Reflections on the Logic of Nonsense*; Krister Segerberg, *A Contribution to Nonsense-Logics*. *Journal of Symbolic Logic*, 33(1):134–136.
- [58] Deutsch, H. (1977). Relevant analytic entailment. *The Relevance Logic Newsletter*, 2(1):26–44.
- [59] Deutsch, H. (1979). The completeness of S. *Studia Logica*, 38(2):137–147.
- [60] Deutsch, H. (1981). *A Family of Conforming Relevant Logics*. PhD thesis, University of California Los Angeles.

- [61] Deutsch, H. (1984). Paraconsistent analytic implication. *Journal of Philosophical Logic*, 13(1):1–11.
- [62] Deutsch, H. (1985). A note on the decidability of a strong relevant logic. *Studia Logica*, 44(2):159–164.
- [63] Došen, K. (1978). A note on the law of identity and the converse Parry property. *Notre Dame Journal of Formal Logic*, 19(1):174–176.
- [64] Drange, T. (1966). *Type Crossings*. De Gruyter Mouton, The Hague.
- [65] Dunn, J. M. (1972). A modification of Parry’s analytic implication. *Notre Dame Journal of Formal Logic*, 13(2):195–205.
- [66] Dunn, J. M. (1976a). Intuitive semantics for first-degree entailments and ‘coupled trees’. *Philosophical Studies*, 29(3):149–168.
- [67] Dunn, J. M. (1976b). A Kripke-style semantics for R-Mingle using a binary accessibility relation. *Studia Logica*, 35(2):163–172.
- [68] Dunn, J. M. (2000). Partiality and its dual. *Studia Logica*, 66(1):5–40.
- [69] Epstein, R. L. (1981). Relatedness and dependence in propositional logics. *Journal of Symbolic Logic*, 46(1):202–203.
- [70] Epstein, R. L. (1987). The algebra of dependence logic. *Reports on Mathematical Logic*, 21:19–34.
- [71] Epstein, R. L. (1995). *The Semantic Foundations of Logic: Propositional Logics*. Oxford University Press, New York, 2nd edition.
- [72] Epstein, R. L. (2005). Paraconsistent logics with simple semantics. *Logique et Analyse*, 48(189–192):71–86.
- [73] Ferguson, T. M. (2014a). A computational interpretation of conceptivism. *Journal of Applied Non-Classical Logics*, 24(4):333–367.
- [74] Ferguson, T. M. (2014b). Łukasiewicz negation and many-valued extensions of constructive logics. In *Proc. 44th International Symposium on Multiple-Valued Logic (ISMVL 2014)*, pages 121–127, Los Alamitos, CA. IEEE Computer Society.
- [75] Ferguson, T. M. (2014c). Ramsey’s footnote and Priest’s connexive logics (Abstract). *Bulletin of Symbolic Logic*, 20(3):387–388.
- [76] Ferguson, T. M. (2015a). Cut-down operations on bilattices. In *Proc. 45th International Symposium on Multiple-Valued Logic (ISMVL 2015)*, pages 24–29, Los Alamitos, CA. IEEE Computer Society.

- [77] Ferguson, T. M. (2015b). Logics of nonsense and Parry systems. *Journal of Philosophical Logic*, 44(1):65–80.
- [78] Ferguson, T. M. (2016a). Correia semantics revisited. *Studia Logica*, 104(1):145–173.
- [79] Ferguson, T. M. (2016b). Faulty Belnap computers and subsystems of FDE. *Journal of Logic and Computation*, 26(5):1617–1636.
- [80] Ferguson, T. M. (2016c). Rivals to Belnap-Dunn logic on interlaced trilattices. *Studia Logica*, pages 1–26. Accepted.
- [81] Fine, K. (1986). Analytic implication. *Notre Dame Journal of Formal Logic*, 27(2):169–179.
- [82] Fine, K. (2014). Truth-maker semantics for intuitionistic logic. *Journal of Philosophical Logic*, 43(2–3):549–577.
- [83] Fine, K. (2015a). Survey of truthmaker semantics. To appear in the Blackwell Handbook to the Philosophy of Language.
- [84] Fine, K. (2015b). A theory of partial truth.
- [85] Fine, K. (2015c). A theory of truth-conditional content I: Conjunction, disjunction, and negation.
- [86] Fine, K. (2015d). Truthmaker semantics.
- [87] Fine, K. (2016). Angellic content. *Journal of Philosophical Logic*, 45(2):199–226.
- [88] Fitting, M. (1969). *Intuitionistic Logic, Model Theory, and Forcing*. North-Holland Publishing, Amsterdam.
- [89] Fitting, M. (1990). Bilattices in logic programming. In Epstein, G., editor, *Proc. 20th International Symposium on Multiple-Valued Logic (ISMVL 1990)*, pages 238–246, Los Alamitos, CA. IEEE Computer Society.
- [90] Fitting, M. (1994). Kleene’s three-valued logics and their children. *Fundamenta Informaticae*, 20(1–3):113–131.
- [91] Fitting, M. (2006). Bilattices are nice things. In Bolander, T., Hendricks, V., and Pedersen, S. A., editors, *Self-reference*, pages 53–77. CSLI Publications, Stanford.
- [92] Floridi, L. (2005). Is semantic information meaningful data? *Philosophy and Phenomenological Research*, 70(2):351–370.
- [93] Gemes, K. (1994). A new theory of content I: Basic content. *Journal of Philosophical Logic*, 23(6):595–620.

- [94] Gemes, K. (1997). A new theory of content II: Model theory and some alternatives. *Journal of Philosophical Logic*, 26(4):449–476.
- [95] Gentzen, G. (1969). Investigations into logical deduction. In Szabo, M., editor, *The Collected Papers of Gerhard Gentzen*, pages 68–131. North Holland, Amsterdam.
- [96] Ginsberg, M. (1986). Multi-valued logics. In *Proc. Fifth National Conference on Artificial Intelligence (AAAI 1986)*, pages 243–247, Los Altos. Morgan Kaufmann.
- [97] Ginsberg, M. (1988). Multivalued logics: A uniform approach to reasoning in artificial intelligence. *Computational Intelligence*, 4(3):265–316.
- [98] Girard, J.-Y. (1987). Linear logic. *Theoretical Computer Science*, 50(1):1–102.
- [99] Goddard, L. and Routley, R. (1973). *The Logic of Significance and Context*, volume 1. Halsted Press, New York.
- [100] Gödel, K. (1933). Eine Interpretation des intuitionistischen Aussagenkalküls. In *Ergebnisse eines mathematischen Kolloquiums*, volume 4, pages 39–40.
- [101] Gödel, K. (1986). On Parry’s axioms. In Feferman, S., Dawson, Jr., J. W., Kleene, S. C., Moore, G. H., Solovay, R. M., and van Heijenoort, J., editors, *Collected Works*, volume I, page 267. Oxford University Press, Oxford.
- [102] Grzegorzczuk, A. (1964). A philosophically plausible formal interpretation of intuitionistic logic. *Indagationes Mathematicae*, 26:596–601.
- [103] Halldén, S. (1948). A question concerning a logical calculus related to Lewis’ system of strict implication, which is of special interest for the study of entailment. *Theoria*, 14(3):265–269.
- [104] Halldén, S. (1949). *The Logic of Nonsense*. Lundequista Bokhandeln, Uppsala, Sweden.
- [105] Harel, D., Kozen, D., and Tiuryn, J. (2002). Dynamic logic. In Gabbay, D. and Guenther, F., editors, *Handbook of Philosophical Logic*, volume 4, pages 99–218. Kluwer Academic Publishers, London, second edition.
- [106] Hempel, C. (1950). Problems and changes in the empiricist criterion of meaning. *Revue Internationale de Philosophie*, 41(11):41–63. Reprinted in [19]: 108–129.
- [107] Hintikka, J. (1962). *Knowledge and Belief*. Texts in Philosophy. King’s College Publications.
- [108] Hume, D. (1888). *A Treatise on Human Nature*. Oxford University Press, New York.
- [109] Ishii, T. (1997). Propositional calculus with identity. Technical Report IS-RR-97-0042F, Japan Advanced Institute of Science and Technology, Nomi City, Japan.

- [110] Ishii, T. (1998). Propositional calculus with identity. *Bulletin of the Section of Logic*, 27(3):96–104.
- [111] Jackson, F. (1994). Armchair metaphysics. In Michael, M. and O’Leary-Hawthorne, J., editors, *Philosophy in Mind*, pages 23–42. Kluwer, Dordrecht.
- [112] Jaśkowski, S. (1948). Rachunek zdań dla systemów dedukcyjnych sprzecznych. *Studia Societatis Scientiarum Torunensis*, Sect. A,I(5):57–77.
- [113] Jennings, R. E. (1994). *The Genealogy of Disjunction*. Oxford University Press, Oxford.
- [114] Jennings, R. E. and Chen, Y. (2010). Articular models for first-degree paraconsistent systems. In *Proc. 9th IEEE International Conference on Cognitive Informatics (ICCI 2010)*, pages 904–907, Los Alamitos, CA. IEEE Computer Society.
- [115] Jennings, R. E., Chen, Y., and Sahasrabudhe, J. (2011). On a new idiom in the study of entailment. *Logica Universalis*, 5(1):101–113.
- [116] Johnson, F. A. (1976). A three-valued interpretation for a relevance logic. *The Relevance Logic Newsletter*, 1(3):123–128.
- [117] Johnson, F. A. (1977). A natural deduction relevance logic. *Bulletin of the Section of Logic*, 6(4):164–170.
- [118] Kant, I. (1999). *Critique of Pure Reason*. Cambridge University Press, New York. Translated by P. Guyer and A. W. Wood.
- [119] Kapsner, A. (2014). *Logics and Falsifications*. Springer, Cham.
- [120] Kielkopf, C. F. (1975). Adjunction and paradoxical derivations. *Analysis*, 35(4):127–129.
- [121] Kielkopf, C. F. (1977). *Formal Sentential Entailment*. University Press of America, Washington, D.C.
- [122] Kleene, S. C. (1952). *Introduction to Metamathematics*. North-Holland Publishing Company, Amsterdam.
- [123] Kneale, W. and Kneale, M. (1962). *The Development of Logic*. Oxford University Press, Oxford.
- [124] Kripke, S. (1965). Semantical analysis of intuitionistic logic I. In Crossley, J. and Dummett, M., editors, *Formal Systems and Recursive Functions*, pages 92–130. North-Holland Publishing, Amsterdam.
- [125] Lappin, S. (1981). *Sorts, Ontology, and Metaphor*. De Gruyter, New York.

- [126] Lewis, C. I. (1918). *A Survey of Symbolic Logic*. University of California Press, Berkeley, CA.
- [127] Lewis, C. I. and Langford, C. H. (1959). *Symbolic Logic*. Dover, New York, second edition.
- [128] Lewis, D. (1973). *Counterfactuals*. Harvard University Press, Cambridge, MA.
- [129] Loptson, P. (1980a). Logic and contingent existence. *History and Philosophy of Logic*, 1(1–2):171–185.
- [130] Loptson, P. (1980b). Q, entailment, and the Parry property. *Logique et Analyse*, 23(90–91):305–317.
- [131] McCall, S. (2012). A history of connexivity. In Gabbay, D. M., Pelletier, F. J., and Woods, J., editors, *Handbook of the History of Logic*, volume 11, pages 415–449. North-Holland, Oxford.
- [132] McCarthy, J. (1963). A basis for a mathematical theory of computation. In Braffort, P. and Hirschberg, D., editors, *Computer Programming and Formal Systems*, pages 33–70. North-Holland Publishing Company, Amsterdam.
- [133] McKinsey, J. C. C. and Tarski, A. (1948). Some theorems about the sentential calculi of Lewis and Heyting. *Journal of Symbolic Logic*, 13(1):1–15.
- [134] Mulligan, K., Simons, P., and Smith, B. (1984). Truth-makers. *Philosophy and Phenomenological Research*, 44(3):287–321.
- [135] Nelson, D. (1949). Constructible falsity. *Journal of Symbolic Logic*, 14(1):16–26.
- [136] Nelson, D. (1959). Negation and separation of concepts in constructive systems. In Heyting, A., editor, *Constructivity in Mathematics*, pages 208–225. North-Holland, Amsterdam.
- [137] Nelson, D. and Almukdad, A. (1984). Constructible falsity and inexact predicates. *Journal of Symbolic Logic*, 49(1):231–233.
- [138] Nowak, M. (2002). Two logics of analytic classical implication. *Logica Trianguli*, 6:25–40.
- [139] Nowak, M. (2008). The logics of analytic equivalence. *Bulletin of the Section of Logic*, 37(3/4):265–272.
- [140] Oller, C. A. (1999). Paraconsistency and analyticity. *Logic and Logical Philosophy*, 7:91–99.

- [141] Parks-Clifford, J. E. (1989). Literal relevance. In Norman, J. and Sylvan, R., editors, *Directions in Relevant Logic*, Reason and Argument, pages 59–76. Kluwer Academic Publishers, Boston, MA.
- [142] Parry, W. T. (1932). *Implication*. PhD thesis, Harvard University.
- [143] Parry, W. T. (1933). Ein Axiomensystem für eine neue Art von Implikation (analytische Implikation). In *Ergebnisse eines mathematischen Kolloquiums*, volume 4, pages 5–6.
- [144] Parry, W. T. (1968). The logic of C. I. Lewis. In Schilpp, P. A., editor, *The Philosophy of C. I. Lewis*, The Library of Living Philosophers, pages 115–154. Open Court, La Salle, IL.
- [145] Parry, W. T. (1972). Comparison of entailment theories. *Journal of Symbolic Logic*, 37(2):441–442.
- [146] Parry, W. T. (1976a). Comparison of entailment theories. *The Relevance Logic Newsletter*, 1(1):16–26.
- [147] Parry, W. T. (1976b). Entailment: Analytic implication vs. the entailment of Anderson and Belnap. *The Relevance Logic Newsletter*, 1(1):11–15.
- [148] Parry, W. T. (1989). Analytic implication: its history, justification, and varieties. In Norman, J. and Sylvan, R., editors, *Directions in Relevant Logic*, Reason and Argument, pages 101–118. Kluwer Academic Publishers, Boston.
- [149] Perry, J. (1986). From worlds to situations. *Journal of Philosophical Logic*, 15(1):83–107.
- [150] Piróg-Rzepecka, K. (1977). *Systemy Nonsense-Logics*. PWN, Warsaw.
- [151] Pizzi, C. and Williamson, T. (1997). Strong Boethius' thesis and consequential implication. *Journal of Philosophical Logic*, 26(5):569–588.
- [152] Pohlers, W. (2008). *Proof Theory*. Springer, Berlin.
- [153] Popper, K. (1972). *The Logic of Scientific Discovery*. Hutchinson, London, sixth edition.
- [154] Priest, G. (1979). The logic of paradox. *Journal of Philosophical Logic*, 8(1):219–241.
- [155] Priest, G. (1999). Negation as cancellation and connexive logic. *Topoi*, 18(2):141–148.
- [156] Priest, G. (2010). The logic of the catuskoti. *Comparative Philosophy*, 1(2):24–54.
- [157] Reichenbach, H. (1944). Bertrand Russell's logic. In Schilpp, P., editor, *The Philosophy of Bertrand Russell*, pages 21–54. Northwestern University Press, Chicago.

- [158] Rescher, N. (1964). *Hypothetical Reasoning*. Studies in Logic and the Foundations of Mathematics. North-Holland Publishing Company, Amsterdam.
- [159] Restall, G. (1996). Truthmakers, entailment and necessity. *Australasian Journal of Philosophy*, 74(2):331–340.
- [160] Restall, G. (2000a). *An Introduction to Substructural Logics*. Routledge, New York.
- [161] Restall, G. (2000b). Modelling truthmaking. *Logique et Analyse*, 43(169–170):211–230.
- [162] Restall, G. (2009). Truthmakers, entailment and necessity 2008. In Lowe, E. J. and Rami, A., editors, *Truth and Truth-Making*, pages 98–101. Acumen, Stocksfield.
- [163] Riviuccio, U. (2013). Representation of interlaced trilattices. *Journal of Applied Logic*, 11(2):174–189.
- [164] Robinson, J. A. (1965). A machine-oriented logic based on the resolution principle. *Journal of the ACM*, 12(1):23–41.
- [165] Rosenberg, J. F. (1972). Russell on negative facts. *Noûs*, 6(1):27–40.
- [166] Routley, R. (1982). *Relevant Logics and their Rivals*, volume 1. Ridgeview Publishing, Atascadero, CA.
- [167] Routley, R. and Meyer, R. K. (1976). Every sentential logic has a two-valued worlds semantics. *Logique et Analyse*, 19(74–76):345–365.
- [168] Routley, R. and Routley, V. (1972). The semantics of first degree entailment. *Noûs*, 6(4):335–359.
- [169] Russell, B. (1918). The philosophy of logical atomism. *The Monist*, 4(1):495–527.
- [170] Russell, B. (1920). *Introduction to Mathematical Philosophy*. George Allen and Unwin, London, second edition.
- [171] Ryle, G. (1949). *The Concept of Mind*. Hutchinson’s University Library, London.
- [172] Segerberg, K. (1965). A contribution to nonsense-logics. *Theoria*, 31(3):199–217.
- [173] Shramko, Y. (2016). Truth, falsehood, information, and beyond: The American plan generalized. In Bimbó, K., editor, *J. Michael Dunn on Information Based Logics*, volume 8 of *Outstanding Contributions to Logic*, pages 191–212. Springer, Dordrecht.
- [174] Shramko, Y., Dunn, J. M., and Takenaka, T. (2001). The trilattice of constructive truth values. *Journal of Logic and Computation*, 11(1):761–788.
- [175] Shramko, Y. and Wansing, H. (2005). Some useful 16-valued logics: How a computer network should think. *Journal of Philosophical Logic*, 35(2):121–153.

- [176] Sider, T. (2005). Another look at Armstrong's combinatorialism. *Noûs*, 39(4):679–695.
- [177] Smiley, T. (1960). Sense without denotation. *Analysis*, 20(6):125–135.
- [178] Smullyan, R. and Fitting, M. (1996). *Set Theory and the Continuum Problem*. Oxford University Press, New York.
- [179] Sørensen, M. and Urzyczyn, P. (2006). *Lectures on the Curry-Howard Isomorphism*. Studies in Logic and the Foundations of Mathematics. North-Holland Publishing Company, New York.
- [180] Stalnaker, R. (1986). Possible worlds and situations. *Journal of Philosophical Logic*, 15(1):109–123.
- [181] Strawson, P. F. (1952). *Introduction to Logical Theory*. John Wiley and Sons, New York.
- [182] Suszko, R. (1968). Ontology in the *Tractatus* of L. Wittgenstein. *Notre Dame Journal of Formal Logic*, 9(1):7–33.
- [183] Sylvan, R. (1988a). Relevant containment logics and certain frame problems of AI. *Logique et Analyse*, 31:11–24.
- [184] Sylvan, R. (1988b). Relevant containment logics, and frame problems. In Gero, J. S. and Stanton, R., editors, *Artificial Intelligence Developments and Applications*, pages 169–181. Elsevier, New York.
- [185] Sylvan, R. (2000a). On reasoning: (possible) reason for (and also against), and relevance. In Hyde, D. and Priest, G., editors, *Sociative Logics and their Applications*, Western Philosophy Series, pages 141–174. Ashgate Publishing, Burlington, VT.
- [186] Sylvan, R. (2000b). Relevant containment logics and certain frame problems of AI. In Hyde, D. and Priest, G., editors, *Sociative Logics and their Applications*, Western Philosophy Series, pages 175–188. Ashgate Publishing, Burlington, VT.
- [187] Szmuc, D. (2016). Track-down operations on bilattices. Manuscript.
- [188] Urquhart, A. (1973). A semantical theory of analytic implication. *Journal of Philosophical Logic*, 2(2):212–219.
- [189] van Fraassen, B. C. (1969). Facts and tautological entailments. *Journal of Philosophy*, 66(15):477–487.
- [190] van Rooij, R. (2010). Conjunctive interpretation of disjunction. *Semantics and Pragmatics*, 3(11):1–28.
- [191] Walton, D. N. (1980). Conditionals in act-sequences. In Epstein, R. L., editor, *Relatedness and Dependence in Propositional Logics*. Iowa State University Logic Group.

- [192] Wansing, H. (2008). Constructive negation, implication, and co-implication. *Journal of Applied Non-Classical Logics*, 18(2–3):341–364.
- [193] Wansing, H. (2010a). Connexive logic. In Zalta, E. N., editor, *The Stanford Encyclopedia of Philosophy*. Fall 2010 edition. <http://plato.stanford.edu/archives/fall2010/entries/logic-connexive/>.
- [194] Wansing, H. (2010b). Proofs, disproofs, and their duals. In Beklemishev, L. D., Goranko, V., and Shehtman, V., editors, *Advances in Modal Logic*, volume 8, pages 483–505, London. College Publications.
- [195] Williamson, T. (1994). *Vagueness*. Routledge, New York.
- [196] Wittgenstein, L. (1922). *Tractatus Logico-Philosophicus*. Harcourt, Brace, and Co., New York. Ogden, C.K., trans.
- [197] Wójcicki, R. (1994). Semantyka sytuacyjna logiki niefregowskiej. In Pelc, J., editor, *Znaczenie i prawda: Rozprawy semiotyczne*. Wydawn. Nauk. PWN, Warsaw.
- [198] Woodruff, P. (1969). *Foundations of Three-Valued Logic*. PhD thesis, University of Pittsburgh.
- [199] Woodruff, P. (1973). On constructive nonsense logic. In *Modality, Morality, and Other Problems of Sense and Nonsense*, pages 192–205. GWK Gleerup Bokforlag, Lund.
- [200] Yablo, S. (2014). *Aboutness*. Princeton University Press, Princeton.
- [201] Zimmerman, T. E. (2000). Free choice disjunction and epistemic possibility. *Natural Language Semantics*, 8(4):255–290.
- [202] Zinov'ev, A. A. (1973). *Foundations of the Logical Theory of Scientific Knowledge (Complex Logic)*. Boston Studies in the Philosophy of Science. D. Reidel Publishing Company, Dordrecht, Holland.