

THE REAL IMPLEMENTATION OF NLMS CHANNEL EQUALIZER INTO THE SYSTEM OF SOFTWARE DEFINED RADIO

Radek MARTINEK¹, Jan ZIDEK¹

¹Department of Measurement and Control, Faculty of Electrical Engineering and Computer Science, VSB-Technical University of Ostrava, 17. listopadu 15/2172, 708 33 Ostrava, Czech Republic

martinek.radek@gmail.com, jan.zidek@vsb.cz

Abstract. *This paper deals with modern wireless transmission systems. It focusses on real implementation of NLMS channel equalizer into the system of software defined radio. The authors aimed to conduct a real measurement (BER vs. E_b/N_o) using modern modular PXI measuring apparatus. This sophisticated measuring system is built by vector-signal generator RF VSG NI PXI-5670 and vector-signal analyzer RF VSA NI PXI-5660. The results of experiments suggest that the channel equalizer with implemented NLMS algorithm has better results (balance between simplicity and performance) than conventionally most used LMS algorithm. This holds true if feasible computational complexity with respect to real time processes is assumed.*

Keywords

Channel equalizer, modular system PXI, NLMS algorithm, software defined radio.

1. Introduction

Continuous grow of data transmission using wireless networks can be observed during the year 2012. The providers of wireless transmission of data demand more effective use of the frequency band. This demand corresponds to the appearance of new wireless technologies and standards. Therefore, new systems must be developed, which would lead to minimization of influence of disturbing phenomena in the radio transmission channel [20] of modern wireless transmission systems.

This would lead to an increase of transmission speed with stress on efficiency of the frequency band use [12]. The chosen approach, software defined SDR radio [1], [10] is very suitable for development and testing of such new systems. The key role for these transmission systems plays the software, which can be flexibly changed according to user's needs. The flexibility of used

measuring apparatus is stressed in this study. Advantages of this approach in view of designing real applications are described.

The authors deal with the implementation of equalization techniques [17] in the SDR system in order to minimize the signal-to-noise ratio SNR [20] of the transmission channel and thus reduce the transmission error rate BER [18]. Several recent publications are devoted to the channel equalizers issues. However, most of them do not deal with the real implementation. Functionality of suggested methods is verified by computer simulations. Some of these algorithms cannot be used despite their very good results in simulations because they are too sensitive to inaccuracy of the computation.

The authors use the results of their own study published in [1], concur on it and extend it. In [1] the authors dealt with the implementation of LMS equalizer [2] into SDR system. The results of conducted experiments suggested that equalization with the use of LMS algorithm is [12] insufficient for modern communication systems. Researched adaptive LMS algorithm is simple and undiscerning from a mathematical point of view [1].

On the other hand, it reached smaller convergence speed in real applications and there was a larger filtration process error; this matter of fact is motivated by plenty of other publications, e.g. [2], [3], and [1]. Therefore, authors address in this paper real implementation of normalized LMS (NLMS - Normalized Least Mean Squares) equalizer [2]. This algorithm should have better results, as several recent studies suggest e.g. [1], [2], and [3].

2. Disturbances in Transmission Radio Channel

This paper focusses on the correction of influence of disturbing phenomena [18], [5] arising in transmission in the communication channel. These unwanted effects are

usually frequency (or linear) distortion (e.g. various types of signal leakage, caused by multipath wave propagation or other physical phenomena, various atmospheric or industrial disturbances, etc.). In these cases, the radio channel can be considered as linear and it is possible to compensate its linear distortion in the receiver using equalization circuits placed in the interference part or mostly behind the demodulator.

Distortion is quite a common phenomenon, which can be met in wireless communication networks. Distortion can be characterized as a set of physical phenomena which add to the primary signal another disturbing signal. Disturbance belongs to the group of phenomena degrading the signal, which is after passing through a communication channel subject to reflection and refraction. The receiver error probability depends in various applications of radar technology on the strength of the noise, statistical distribution of the signal amplitude and the input. Probability density of the amplitude of the noise added to a harmonic carrier frequency of a given amplitude is described by noise probability distribution. Character of the noise is given by the kind of the disturbance which effects the transmission channel. There are several kinds of disturbance, more details in [19], [6] and [22].

3. Methods of Adaptive Equalization

The principle of function of most adaptive equalizers is based on the principle of input digital distorted data sequence correction in the receiver, realized using a frequency adaptive filter [14]. The adaptive filter parameters (coefficients) are changed depending on the continuously changing parameters of the distorting communication channel [16], [12]. When correct function of the equalizer is reached, the data sequence at the output is identical, or very little different from the sequence at the transmitter output. For proper operation of adaptive equalizer it is necessary to know, or exactly as possible estimate the constantly changing parameters of the channel. This estimate can be done in several ways [4]. Most of them are based on the principle of periodic broadcast - defined training data sequences. The equalizer of receiver knows the structure of this data sequences. The data block of GSM is 114 bits long and it is divided into two equal 57 bits long parts. The training sequence of 26 bits is inserted between them [21]. A more detailed description of the techniques of the training input data sequences can be found in [20], [19] and [21]. Equalizer operates cyclically in two modes:

- Training Mode [1] - the transmitter broadcasts the training sequence. It inputs in a distorted shape to the adaptive filter of receiver. The parameters of the filter are set during the evaluation of training period to ideally correct the channel distortion.
- Tracking Mode [1] - a monitoring mode follows

after the finishing the training sequence. The data sequence is broadcasted and its equalized output signal should be similar to the original signal as much as possible.

Figure 1 shows the general concept of a communication system with adaptive equalizer [1]. A detailed description of the implementation of adaptive equalizer in a communication system can be found in [1], [8].

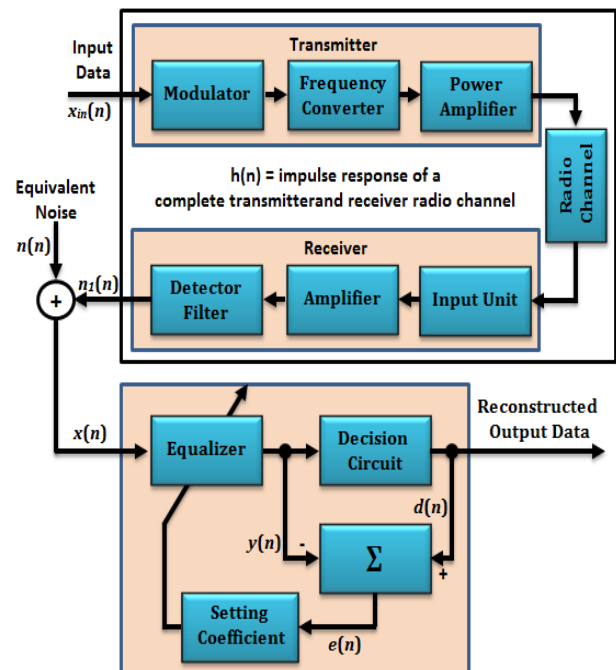

Fig. 1: General scheme of equalizer.

4. NLMS Adaptive Equalizer

Adaptive equalizer of the frequency characteristic (channel equalizer) is used in digital communication systems when dealing with the transmission of the data through a non-ideal channel. The key part of the adaptive equalizer is FIR filter (Fig. 2), which compensates channel distortion. Coefficients of the filter [13] are actualized through an adaptive algorithm; this paper focusses on NLMS algorithm.

4.1. Adaptive Filtration

Figure 2 shows the linear transversal filter, which is used in this work like the fundamental. In Fig. 2, $x(n)$ represents input vector of samples, $y(n)$ represents the adaptive filter output, $d(n)$ is the desired response, $e(n)$ represents the error signal (estimated error), w_i represents the coefficients of a vector transversal FIR filter weights and z^{-1} represents the delay.

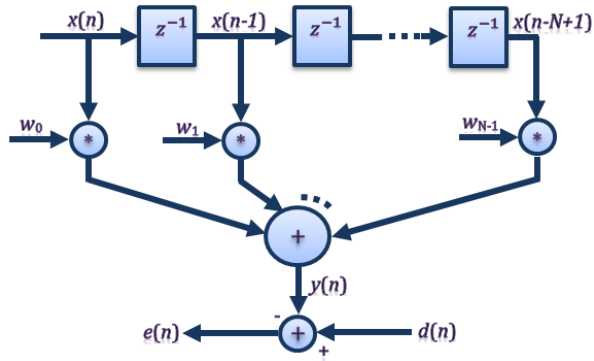

Fig. 2: Scheme of adaptive filter in detail (linear transversal filter).

In this paper, the input signal in the form of a column vector will be defined by the equation [14]:

$$\mathbf{x}(n) = [x(n) \ x(n-1) \ x(n-2) \ \dots \ x(n-N+1)]^T. \quad (1)$$

Transversal filter weights vector (represents the adaptive FIR filter coefficients) will take the form [14]:

$$\mathbf{w}(n) = [w_0(n) \ w_1(n) \ w_2(n) \ \dots \ w_{N-1}(n)]^T. \quad (2)$$

The output signal of the adaptive transversal filter can be described using the equation

$$y(n) = \sum_{i=0}^{N-1} w_i(n)x(n-i). \quad (3)$$

It is a filter of N -th order, so the extent of indexing from 0 to $N-1$ is used. It can be seen as equivalent to the scalar product of the vector impulse response and input vector, and alternatively as a weights vector of transposing the filter and input vector, see equation:

$$y(n) = \mathbf{w}(n) \cdot \mathbf{x}(n) = \mathbf{w}^T(n) \mathbf{x}(n). \quad (4)$$

The main target of the weights adaptation process is the gradual reduction of the objective function (criterial function) value of $\zeta(n)$ to its minimum. Criterial function $\zeta(n)$ depends only on the values $e(n)$ of the error function therefore it depends on the difference of desired value and actual value (It means that $\zeta(n)$ is the difference of desired output and actual output of FIR filter):

$$e(n) = d(n) - y(n). \quad (5)$$

According to experiments which were carried out, there was implemented basic representative of adaptive algorithms, called the MSE (Mean Square Error) [15] of adaptive filter (LMS algorithm). The main aim of the whole process is a gradual reduction of the objective function value $\zeta(n)$ to its minimum (the smallest value of mean square error)

$$\xi(n) = E[e^2(n)] = E[(d(n) - y(n))^2]. \quad (6)$$

4.2. Derivation of the NLMS Algorithm

To derive the NLMS algorithm we consider the standard

LMS recursion, for which we select a variable step size parameter, $\mu(n)$. This parameter is selected so that the error value, $e^+(n)$, will be minimized using the updated filter tap weights, $w(n+1)$, and the current input vector, $\mathbf{x}(n)$ [15].

$$\begin{aligned} \mathbf{w}(n+1) &= \mathbf{w}(n) + 2\mu(n)e(n)\mathbf{x}(n) \\ e^+(n) &= d(n) - \mathbf{w}^T(n+1)\mathbf{x}(n) = \\ &= (1 - 2\mu(n)\mathbf{x}^T(n)\mathbf{x}(n))e(n). \end{aligned} \quad (7)$$

Next we minimize $(e^+(n))^2$, with respect to $\mu(n)$. Using this we can then find a value for $\mu(n)$ which forces $e^+(n)$ to zero [15].

$$\mu(n) = \frac{1}{2\mathbf{x}^T(n)\mathbf{x}(n)}. \quad (8)$$

This $\mu(n)$ is then substituted into the standard LMS recursion replacing μ , resulting in the following.

$$\begin{aligned} \mathbf{w}(n+1) &= \mathbf{w}(n) + 2\mu(n)e(n)\mathbf{x}(n) = \\ &= \mathbf{w}(n) + \frac{1}{\mathbf{x}^T(n)\mathbf{x}(n)}e(n)\mathbf{x}(n). \end{aligned} \quad (9)$$

4.3. Implementation of the NLMS Algorithm

Each iteration of the NLMS algorithm requires these steps in the following order.

- 1) The output of the adaptive filter is calculated [15].

$$y(n) = \sum_{i=0}^{N-1} w_i(n)x(n-i) = \mathbf{w}^T(n)\mathbf{x}(n). \quad (10)$$

- 2) An error signal is calculated as the difference between the desired signal and the filter output.

$$e(n) = d(n) - y(n). \quad (11)$$

- 3) The step size value for the input vector is calculated.

$$\mu(n) = \frac{1}{\mathbf{x}^T(n)\mathbf{x}(n)}. \quad (12)$$

- 4) The filter tap weights are updated in preparation for the next iteration.

$$\mathbf{w}(n+1) = \mathbf{w}(n) + \mu e(n)\mathbf{x}(n). \quad (13)$$

Each iteration of the NLMS algorithm requires $3N+1$ multiplications, this is only N more than the standard LMS algorithm, this is an acceptable increase considering the gains in stability and echo attenuation achieved.

5. Real Implementation

The authors used a modular platform PXI [12] for a real implementation of NLMS adaptive equalizer. This platform applies a trend of software-based transmission systems. The authors used programming language G [12] in LabVIEW 2011, SP1 [23], [11] to build a software part of the filter. The principal scheme of the measuring apparatus is shown in Fig. 3.

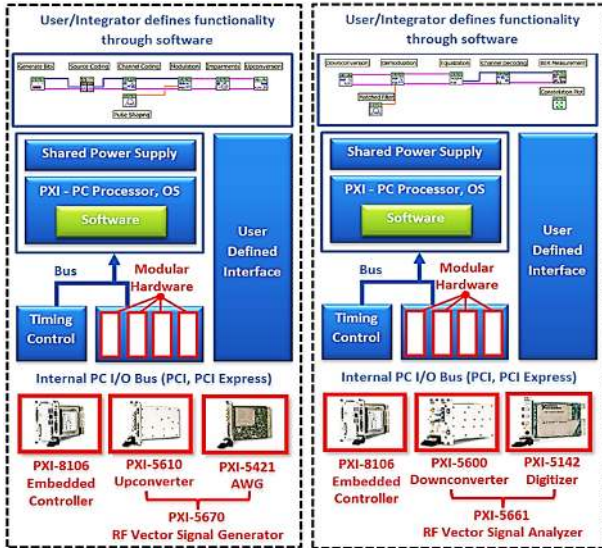

Fig. 3: Structure of used modular measuring apparatus PXI.

Particular blocks of the transmission chain were built using library functions NI LabVIEW – Toolkits for Communication [24] (Modulation Toolkit, Spectral Measurements Toolkit, Advanced Signal Analysis Toolkit, DFD Toolkit). Simplified structure of emitter and receiver blocks is shown in Fig. 4.

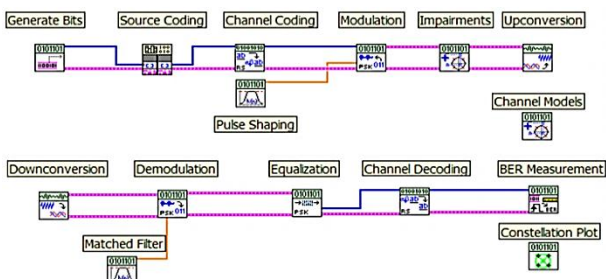

Fig. 4: Setting of particular blocks of the transmitting chain in the program structure LabVIEW 2011, SP1.

For measurement, two modular systems PXI were used: 1) RF vector signal generator NI PXI-5670 (Fig. 5) is a user-defined waveform generator, working with 16 bit resolution and sampling rate of 100 MS^{-1} (400 MS^{-1} in interleaved mode) with a depth of memory 512 MB and the real bandwidth of 20 MHz. Using digital upconverter, this module can generate a signal in the band from 250 kHz to 2,7 GHz [7]. 2) NI PXI-5660 (Fig. 6) module was used for the analysis of digitally modulated signals [24]. This module represents very compact solution (30 % of normal weight and performance of

individual devices in this class), allowing very rapid measurement of digitally modulated signals in the band from 9 kHz to 2,7 GHz. The real bandwidth 20 MHz, but with possible data rate $132 \text{ MB} \cdot \text{s}^{-1}$ using the PCI bus, this solution represents enormous progress compared to 1 MB using GPIB interface designated for connection of separated vector signal analyzers, see [8].

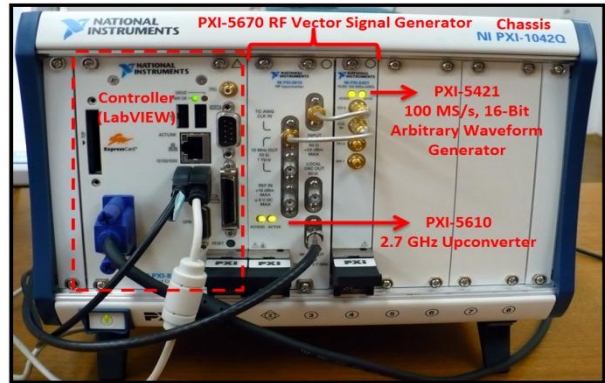

Fig. 5: Real scheme of NI PXI 5670 - Vector Signal Generator (NI PXI-5610 – RF Upconverter, NI PXI-5421 -100 MS^{-1} AWG).

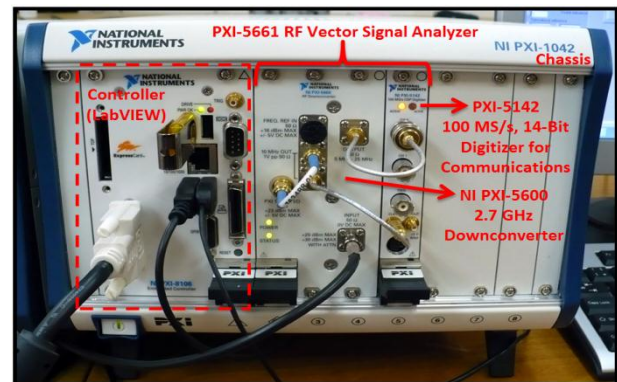

Fig. 6: Real scheme of NI PXI 5661 - Vector Signal Analyzer (NI PXI-5600 – RF Downconverter, NI PXI-5142 -100 MS^{-1} OSP Digitizer).

Connection of particular plug-in measuring modules of PXI system is shown in Fig. 7.

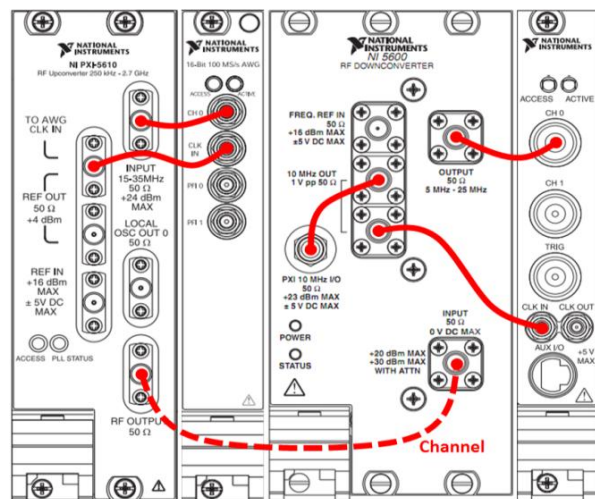

Fig. 7: Connection of PXI measuring system.

6. Experimental Results

For verification of the real features of the designed system NI PXI, a passive omnidirectional WiFi Antenna TP-LINK TL ANT2405C with 5 dBi gain – was connected to output of broadcast part of the system and the receiver was affixed with the passive panel sector WiFi Antenna Centurion Wireless Technologies with 9 dBi of gain. In the transmitter the signal was generated by the studied modulations (64 QAM, 256 QAM) on the carrier frequency 1,96 GHz, power level of 10 dBm signal with a bandwidth 3,84 MHz, Roll factor α of the root raised cosine filter 0,33 and symbol rate $2,625 \text{ MS}\cdot\text{s}^{-1}$. On the receiver side, the quality of the received signal was evaluated by the BER measurement.

The measurement was carried out in the laboratory of the size of $6\times 14 \text{ m}$, while transmitting and receiving antennas were situated in opposite corners of the laboratory. The room was equipped by the conventional office equipment.

A constellation diagram [9] of received signal without applying adaptive equalizer for 256 QAM is shown in Fig. 8. Figure 9 shows constellation diagram of received signal with NLMS adaptive equalizer applied for 256 QAM.

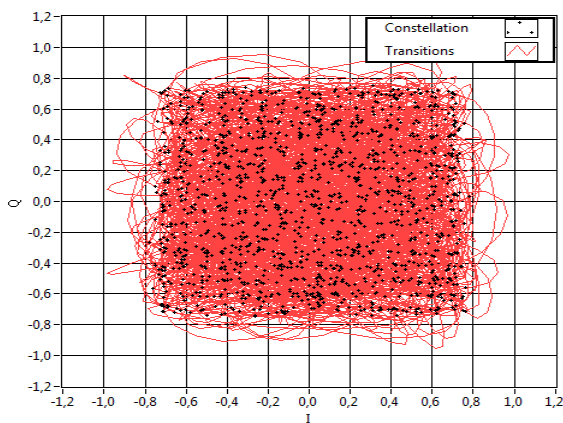

Fig. 8: Constellation diagram of received signal without equalization for 256 QAM.

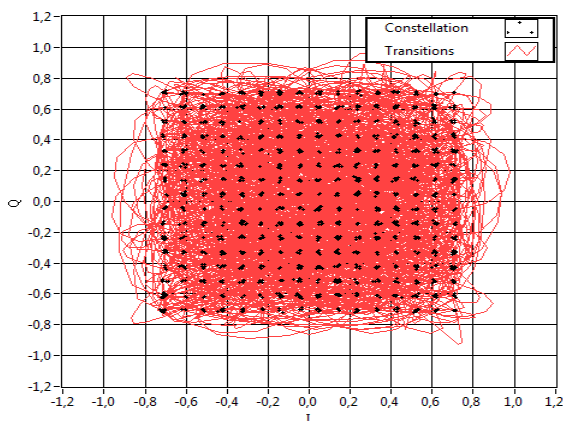

Fig. 9: Constellation diagram of received signal if NLMS adaptive equalizer is used, for 256 QAM.

In Fig. 10 eye diagram [9] of received signal without adaptive equalizer applied for 64 QAM is shown. In Fig. 11 eye diagram of received signal with NLMS adaptive equalizer for 64 QAM is shown.

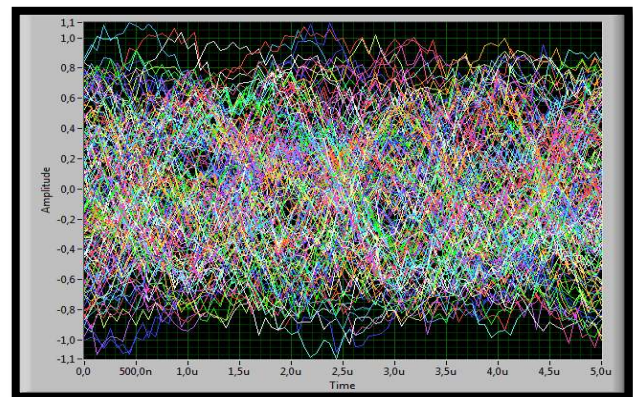

Fig. 10: Eye diagram of received signal without equalization, for 64 QAM.

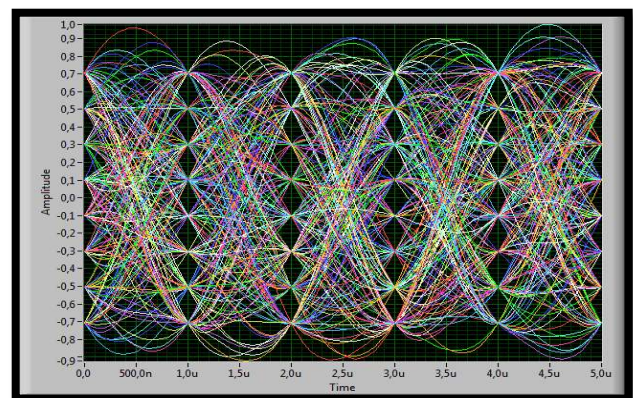

Fig. 11: Eye diagram of received signal if NLMS adaptive equalizer is used, for 64 QAM.

Effectiveness of channel equalizer is characterized by the difference between signal and noise in output, see Fig. 12. Moreover, numbers of iterations, i.e. complexity of the algorithm for achieving optimal estimate of impulse characteristic of the filter in equalizer, see Tab. 1.

Tab.1: Comparison of algorithms LMS and NLMS.

Algorithms	LMS	NLMS
Number of additions/subtractions in one iteration cycle	$M+1$	$2M+1$
Number of multiplications in one iteration cycle.	$2M$	$3M+50$
Usage of memory cells	$2M$	$2M$
Number of multiplications for: $M = n = 64$	8192	15488
Number of multiplications for: $M = n = 102$	$2 \cdot 10^6$	$3 \cdot 10^6$
Time of convergence (rounded)	400	100

Figure 12 shows that for low noise levels (i.e., E_b/N_0 large), the BER is extremely small. However, as noise increases beyond a certain threshold level, the BER rapidly becomes unacceptable.

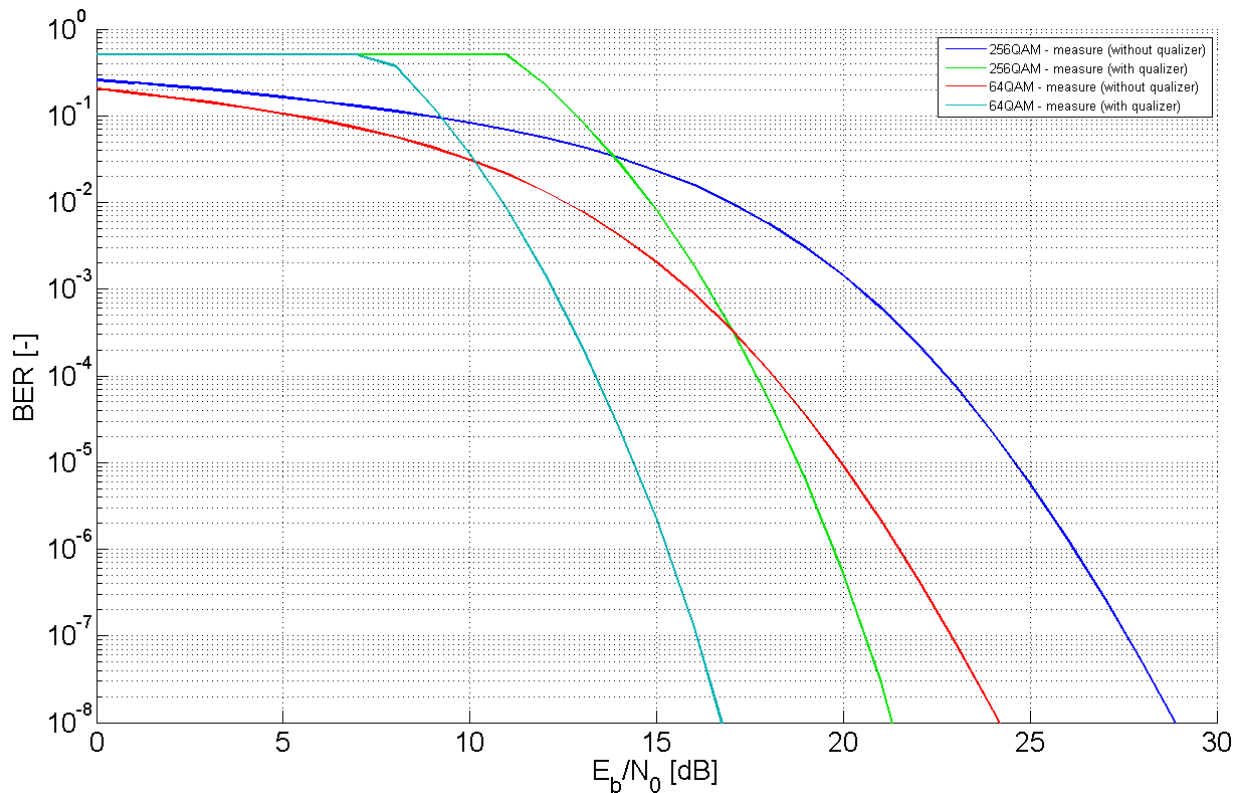

Fig. 12: Dependence of bit error rate on the difference between signal and noise for 64 QAM and 256 QAM.

7. Conclusion

In publication [1], from which this paper results, LMS adaptive equalizer was discussed. LMS algorithm is due to its simplicity the most popular adaptive algorithm. However, LMS algorithm has small convergence speed and bigger filtration process error in real applications. The results of performed experiments suggested that NLMS algorithm is slightly more complicated than LMS algorithm. It is a more robust version of LMS algorithm. It has better experimental results than LMS algorithm (balance between simplicity and performance), results for algorithm LMS, see [1], [2] and [16]. The experiments verified that NLMS algorithm is very useful in real-time applications.

Based on real measurements the authors explored possibilities of implementation of NLMS adaptive equalization into SDR systems, which are build on the hardware platform PXI and virtual instrumentation. Utilization of these modern tools appears very suitable for testing new principles in channel equalization without the necessity of constant upgrade of hardware components and cooperation customer-seller in order to modify the software.

From an economical point of view, flexibility of modular measuring systems protect investment into their purchase. Software part of these systems, which plays the key role for their functionality, can be adjusted to new information technologies. This aspect decreased financial

needs in instrumentation, which should cover new standards in the domain of information and communication systems.

Acknowledgements

This research was supported in part by The Ministry of Education, Youth and Sports of Czech Republic under the project KONTAKT II registration number LH12183.

References

- [1] MARTINEK, Radek, Jan ZIDEK, Karel TOMALA and Lukas KLEIN. Implementation of LMS Equalizer into Software-defined Radio System SDR. In: *13th International Conference on Research in Telecommunication Technologies*. Techov: VUT Brno, 2011, pp. 75-79. ISBN 978-80-214-4283-2.
- [2] PANDEY, Alkon, L. D. MALVIYA and Vineet SHARMA,. Comparative Study of LMS and NLMS Algorithms in Adaptive Equalizer. *International Journal of Engineering Research and Applications (IJERA)*. 2012, vol. 2, iss. 3, pp.1584-1587. ISSN 2248-9622.
- [3] GARHWAL, Anita and P. P. BHATTACHARYA. Performance Enhancement of WiMAX System using Adaptive Equalizer. *Journal of Emerging Trends in Computing and Information Sciences*. 2012, vol. 3, no. 4, pp. 561-565. ISSN 2079-8407.
- [4] MARTINEK, Radek and Jan ZIDEK. Use of Adaptive Filtering for Noise Reduction in Communication systems. In: *The International Conference Applied Electronics (AE)*. Pilsen: IEEE, 2010, pp. 1-6. ISBN 978-80-7043-865-7. ISSN 1803-

- 7332.
- [5] ZIEMER, R. E. and W. H. TRANTER. *Principles of Communications: Systems, Modulations and Noise*. New York: John Wiley & Sons, 2001. 5th ed. ISBN 0471-9253-7.
- [6] STAVROULAKIS, P. *Interference Analysis and Reduction for Wireless Systems*. Boston: Artech House, 2003. ISBN 1-58053-316-7.
- [7] NI PXI-5671 Specifications: RF Vector Signal Analyzer: Hardware User Manual. In: *National Instrument* [online]. 2005. Available at: http://www.ni.com/pdf/manuals/5671_UM.pdf.
- [8] NI PXI-5660 Specifications: RF Vector Signal Analyzer. In: *National Instrument* [online]. 2009. Available at: <http://www.ni.com/pdf/manuals/371320e.pdf>.
- [9] Test, Measurement, and Embedded Systems: PXI Platform. *National Instrument* [online]. 2012. Available at: <http://www.ni.com/pxi>.
- [10] BARD, John and Vincent J. KOVARIK. *Software defined radio: the software communications architecture*. Wiltshire: John Wiley and Sons, 2007. ISBN 978-0470865187.
- [11] LabVIEW System Desing Software. *National Instrument* [online]. 2012. Available at: <http://www.ni.com/labview>.
- [12] MARTINEK, Radek; Mohamed AL WOHAISHI and Jan ZIDEK. Software Based Flexible Measuring Systems for Analysis of Digitally Modulated Systems. In: *The 9th Roedunet International Conference, RoEduNet*. Sibiu: IEEE, 2010, pp. 397-402. ISBN 978-1-4244-7335-9. ISSN 2068-1038.
- [13] DINIZ, Poulou S. R. *Adaptive Filtering: Algorithms and Practical Implementation*. 3rd ed., New York: Springer, 2008. 632 p., ISBN 978-0-387-31274-3.
- [14] HAYKIN, Simon. *Adaptive Filter Theory*. New Jersey: Prentice Hall, 2001. 4th ed. ISBN 978-0130901262.
- [15] HUTSON, Michael. *Acoustic Echo using Digital Signal Processing*. Queensland, 2003. Diploma thesis. The University of Queensland. Supervisor Simon Kaplan.
- [16] ELANGOVA, K. Comparative study on the channel estimation for OFDM system using LMS, NLMS and RLS algorithms. In: *International Conference on Pattern Recognition, Informatics and Medical Engineering (PRIME)*. Salem: IEEE, 2012, pp. 359-363. ISBN 978-1-4673-1037-6. DOI: 10.1109/ICPRIME.2012.6208372.
- [17] RUPP, M. Robust Design of Adaptive Equalizers. *IEEE Transactions on Signal Processing*. 2012, vol. 60, iss. 4, pp. 1612-1626. ISSN 1053-587X. DOI: 10.1109/TSP.2011.2180717.
- [18] HE, Nan. Application of adaptive equalizer in digital microwave communication. In: *Conference On Electronics and Information Engineering (ICEIE)*. Kyoto: IEEE, 2010, V2-497-V2-500. ISBN 978-1-4244-7679-4. DOI: 10.1109/ICEIE.2010.5559759.
- [19] GU, Qizheng. *RF System Design of Transceivers for Wireless Communications*. 1st ed. New York: Springer, 2005. ISBN 978-0-387-24161-6.
- [20] MADHOW, Upamanyu. *Fundamentals of Digital Communication*. Santa Barbara: University of California, 2008. ISBN 9780521874144.
- [21] ZALUD, V. *Moderni radioelektronika*. Praha: BEN, 2000. ISBN 80-86056-47-3.
- [22] HANUS, Stanislav. *Bezdratove a mobilni komunikace*. Brno: T-Mobile CZ, 2005. 1st ed. ISBN 80-214-1833-8.
- [23] ZIDEK, J. *Graficke programovani ve vyvojevem prostredi LabVIEW*. Ostrava: VSB-TU Ostrava, 2005.
- [24] NI LabVIEW. *Modulation Toolkit Help: Software Revision Version: 4.3, Part Number: 370940H-01, 2011.*

About Authors

Radek MARTINEK was born on August 10, 1984 in Nove Mesto na Morave, Czech Republic. He received the Bc. degree in Electrical, Electronic, Communication and Control Technology from Faculty of Electrical Engineering and Communication Brno University of Technology in 2007, the Ing. degree in Communication Technology from Faculty of Electrical Engineering and Computer Science VSB–Technical University of Ostrava in 2009. He is pursuing his Ph.D. in Department of Cybernetics and Biomedical Engineering. His current research interests include digital signal processing and communication systems.

Jan ZIDEK was born in 1957 in Opava, Czech Republic. He received his master degree in Power Engineering from VSB–TU of Ostrava in 1982, finished his Ph.D. study in 1986. From 1991 until 2003 worked as Head of Department of Electrical Measurement, which was established at new Faculty of Electrical Engineering and Computer Science on VSB–TU of Ostrava. He works as vice-dean of this faculty from 2003 and is the member of Department of Measurement and Control. Main interests are graphical programming, automated test and measurement systems design, measurement in communication systems, power quality measurement. He works also as technological manager in ELCOM, Division of Virtual Instrumentation in Science and Technology Park of Ostrava.