



**STRATEGY  
RESEARCH  
PROJECT**

The views expressed in this paper are those of the author and do not necessarily reflect the views of the Department of Defense or any of its agencies. This document may not be released for open publication until it has been cleared by the appropriate military service or government agency.

**THE ROLE OF THE U.S. ARMY MEDICAL DEPARTMENT  
IN DOMESTIC DISASTER ASSISTANCE OPERATIONS -  
LESSONS LEARNED FROM HURRICANE ANDREW**

BY

**COLONEL DALE A. CARROLL**  
United States Army

**DISTRIBUTION STATEMENT A:**  
Approved for public release.  
Distribution is unlimited

19960603 257

USAWC CLASS OF 1996



**U.S. ARMY WAR COLLEGE, CARLISLE BARRACKS, PA 17013-5050**

**DTIC QUALITY INSPECTED 1**

# DISCLAIMER NOTICE

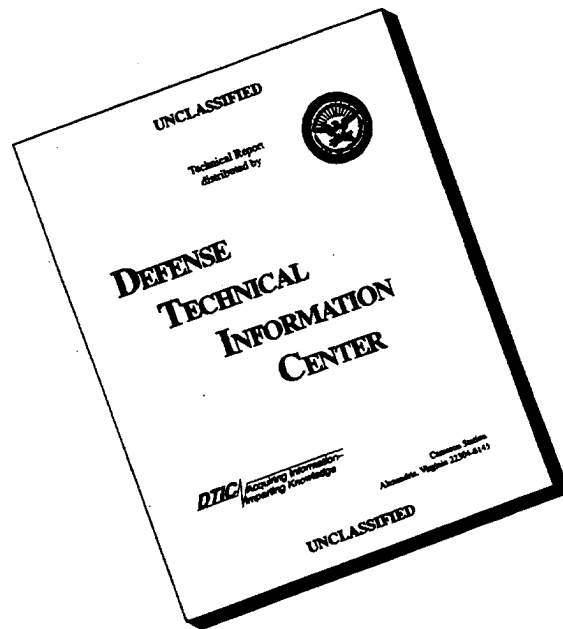

**THIS DOCUMENT IS BEST QUALITY AVAILABLE. THE COPY FURNISHED TO DTIC CONTAINED A SIGNIFICANT NUMBER OF PAGES WHICH DO NOT REPRODUCE LEGIBLY.**

UNCLASSIFIED

USAWC STRATEGY RESEARCH PROJECT

The views expressed in this paper are those of the author and do not necessarily reflect the views of the Department of Defense or any of its agencies. This document may not be released for open publication until it has been cleared by the appropriate military service or government agency.

THE ROLE OF THE U.S. ARMY MEDICAL DEPARTMENT IN DOMESTIC DISASTER ASSISTANCE OPERATIONS - LESSONS LEARNED FROM HURRICANE ANDREW

by

Colonel Dale A. Carroll  
United States Army

Colonel William Allen  
Project Advisor

DISTRIBUTION STATEMENT A: Approved for public release. Distribution is unlimited.

U.S. Army War College  
Carlisle Barracks, Pennsylvania 17013

UNCLASSIFIED

## ABSTRACT

AUTHOR: Dale A. Carroll (Col), USA

TITLE: The Role of the U.S. Army Medical Department in Domestic Disaster Assistance Operations - Lessons Learned from Hurricane Andrew

FORMAT: Strategy Research Paper

DATE: 15 APRIL 1996

PAGES: 40

CLASSIFICATION: Unclassified

Hurricane Andrew, which struck South Dade County, Florida on the morning of 24 August 1992, was the "worst natural disaster ever to hit the United States..." The capabilities of the local and state governments to respond to the disaster were quickly overwhelmed and federal assistance was requested. Due to the scope of the disaster massive Department of Defense (DOD) support was required.

This paper reviews the history of Federal disaster relief legislation and DOD's role in domestic disaster support. It reviews the Federal Response Plan with emphasis on Emergency Support Function 8 (Health and Medical). The study also addresses the Army Medical Department's role in the Hurricane Andrew operations and closes with a review of the medically related Joint Uniform Lessons Learned and the current status of actions to address those Lessons Learned.

## TABLE OF CONTENTS

	PAGE
List of Figures and Tables	v
Abbreviations	vii
Introduction	1
Federal Disaster Response - History	2
The Federal Response Plan	4
Hurricane Andrew	10
DOD Response	11
Joint Task Force Andrew	12
The AMEDD Role	16
Lessons Learned	22
Conclusion	30
Endnotes	35
Bibliography	39



## LIST OF FIGURES AND TABLES

		PAGE
Table 1	Emergency Support Assignment Matrix	6
Figure 1	Decision Sequence for Domestic Disaster Support	13
Figure 2	Joint Task Force Andrew Organization	15
Figure 3	Organization of JTFA Surgeon's Office	18
Figure 4	Organization of Army Medical Support - JTFA	19
Figure 5	Notional Joint Surgeon's Office	29
Appendix 1	Joint Uniform Lessons Learned (Medical)	33





## ABBREVIATIONS

AMEDD	Army Medical Department
AMEDD C&S	AMEDD Center and School
AO	Area of Operations
ARFOR	Army Forces
ASH, HHS/PHS	Assistant Secretary of Health, Department of Health and Human Services, Public Health Service
CINCFOR	Commander in Chief - Forces Command
CMOC	Civilian - Military Operations Center
CONUSA	Continental United States Army
CSH	Combat Support Hospital
DCO	Defense Coordinating Officer
DFO	Disaster Field Office
DMAT	Disaster Medical Assistance Teams
DOD	Department of Defense
DOMS	Directorate of Military Support
ERT	Emergency Response Team
ESF	Emergency Support Function
FCO	Federal Coordinating Officer
FEMA	Federal Emergency Management Agency
FLARNG	Florida Army National Guard
FRP	Federal Response Plan
FWD	Forward
HIV	Human Immunodeficiency Virus
HMTF	Health and Medical Task Force
JTFA	Joint Task Force Andrew
JULLS	Joint Uniform Lessons Learned
LSC	Life Support Center
MED BDE	Medical Brigade
MEDLOG	Medical Battalion (Logistics)
MSCA	Military Support to Civilian Authorities
MSU	Management Support Unit
MTF	Medical Treatment Facility
NDMS	National Disaster Medical System
NGO	Non-governmental Organizations
OASH/OEP	Office of the Assistant Secretary for Health / Office of Emergency Preparedness
PDA	Preliminary Disaster Assessment
PM	Preventive Medicine
PVO	Private Voluntary Organization
RC	Reserve Component
SPMAGTF	Special Purpose Marine Air Ground Task Force

TF	Task Force
USAF	United States Air Force
USAR	United States Army Reserve
USN	United States Navy
USPHS	United States Public Health Service
VA	Department of Veteran's Affairs

## INTRODUCTION

In the early morning hours of 24 August 1992, Hurricane Andrew swept ashore in south Dade County with landfall at Homestead, Florida. It left a path of destruction 35 miles wide as it moved slowly across the state, exiting into the Gulf of Mexico south of Naples. The devastation in south Dade County was so overwhelming that it would be several days before the true magnitude of destruction to cities such as Homestead, Florida City, and Leisure City would be known.

When it became clear that the state and local governments lacked the resources to deal with the catastrophe, the Governor of Florida requested the area be designated a federal disaster area. His request was approved by President Bush, setting in motion the federal disaster response mechanism. As the magnitude of the disaster unfolded, the President tasked the Department of Defense (DOD) and the Secretary of the Army, as the Executive Agent for military support to civilian authorities (MSCA), to provide additional direct disaster assistance in support of the disaster relief operations already underway under the direction of the Federal Emergency Management Agency (FEMA).

Over 23,000 DOD personnel assisted in disaster relief operations in South Florida over the ensuing 54 days as members of Joint Task Force Andrew (JTFA). Hurricane Andrew represented the first opportunity to exercise the new Federal Response Plan (FRP) which had been published in April of 1992 and quickly became the most massive DOD domestic disaster relief contribution to date.

The main objective of this study is to document the DOD response to Hurricane Andrew in the context of the FRP with emphasis on the Army Medical Department (AMEDD) contributions. A second objective is to determine the current status of actions taken to address

the 35 health and medical Joint Uniform Lessons Learned (JULLS) which were developed as a result of the after action review.

This paper will review the history of federal disaster relief legislation and the organization of FEMA. It will also address the FRP with emphasis on the role of DOD in domestic disaster operations and with particular emphasis on Emergency Support Function 8 (ESF 8). ESF 8 is the portion of the FRP dealing with health and medical issues. The functions of the National Disaster Medical System (NDMS) will then be reviewed followed by a discussion of the impact of Hurricane Andrew on South Florida and the activation, deployment, and employment of federal disaster assistance to South Florida. The paper will discuss the organization of the JTFA Surgeon's Office and the activities of DOD medical elements during the operation. The paper will close with a review of the JULLS medical lessons learned from Hurricane Andrew and the status of actions to address the JULLS and suggestions to enhance the medical response to domestic disaster operations.

## **FEDERAL DISASTER RESPONSE - HISTORY**

Although the federal government's role in disaster assistance spans the history of the republic, authorizations to support federal assistance were usually in the form of specific congressional actions in response to specific disasters. After World War II, Congress authorized the President to approve the use of surplus military supplies to assist states and local governments suffering disasters. The Federal Works Administrator was responsible for executing the distribution of the supplies in coordination with the military services and the states. <sup>1</sup>

Public Law 875, the Federal Disaster Act of 1950, was the first attempt at crafting comprehensive federal disaster legislation. Through P.L. 875, the President was empowered to provide assistance to States or local governments suffering disasters. The President could call upon the resources of all federal departments to provide this assistance.<sup>2</sup> P.L. 875 laid the foundation for future federal disaster relief. Current legislation clearly emphasizes federal support to local and state governments rather than federal responsibility for providing disaster relief. Today, the primary responsibility for disaster relief lies with the state and local governments. Only when the state and local governments lack the resources to provide the relief and only if requested will the federal government engage in domestic disaster relief operations.

The Disaster Relief Act of 1974 (P.L. 93-288) provided structure to the federal disaster relief program. It specified duties and responsibilities for the federal agencies involved in disaster relief and required coordination and planning between the federal and state governments.<sup>3</sup>

The Robert T. Stafford Disaster Relief and Emergency Assistance Act of 1988 (P.L. 100-707) serves as the current statutory authority for DOD assistance in domestic disaster assistance operations. The act also clarifies the use of DOD assets in a disaster scenario prior to the crisis' formal designation as a federal disaster. Federal support is determined to be required if "any act of nature or any fire, flood, or explosion which in the determination of the President results in damages of such severity and magnitude that federal aid is needed to supplement the efforts and available resources of the state and local governments."<sup>4</sup> Note that the language stipulates that federal aid will supplement local and state efforts. Since 1978 federal disaster response has been coordinated by FEMA.

FEMA is the federal agency responsible for civil defense and civil emergency planning and the coordination of federal disaster relief. It was created in 1979 to consolidate federal emergency preparedness, disaster mitigation, and response functions which were spread among several different federal departments and agencies.

FEMA seeks to enhance state and local government capabilities for responding to emergencies. Its mission is “to provide leadership and support to reduce the loss of life and property and protect our nation’s institutions from all types of hazards through a comprehensive, risk-based, all-hazards emergency management program of mitigation, preparedness, response and recovery.”<sup>5</sup> It provides federal assistance to citizens recovering from disasters and provides grants to state and local governments in preparation and training for disasters. FEMA serves as the coordinator for the 26 agencies / organizations that provide federal disaster support and provides leadership for disaster mitigation activities.<sup>6</sup> In recognition of the importance of FEMA’s role, the Director of FEMA , a Presidential appointee, was elevated to cabinet level on 26 February 1996.<sup>7</sup>

## **FEDERAL RESPONSE PLAN**

The FRP (PL 93-288, as amended) dictates the scope and provision of federal disaster response. The current FRP was released in April 1992 and is the result of dissatisfaction with federal response to Hurricane Hugo in 1989.<sup>8</sup> There were allegations after Hurricane Hugo that FEMA’s supplemental response was slow and inadequate. Assertions that “the federal government may be the **principle responder** after catastrophic events” (emphasis mine) were heard.<sup>9</sup> As noted above the federal government response to disasters had been considered

supplemental to the state and local efforts. The principle responder designation called for a re-evaluation of the federal disaster response program.

The request of the state government for disaster status must be based on its inability to provide adequate resources to respond to the disaster. FEMA and state officials usually perform the preliminary disaster assessment (PDA) jointly prior to the request for and declaration of a federal disaster. The FRP is activated after a state has obtained a presidential declaration of emergency under the Stafford Act (PL 93-208).

A federal coordinating officer (FCO) is appointed to coordinate the overall federal response to the emergency with state officials and to assist the state officials in determining the requirements for disaster relief and to coordinate with the ESFs to address the requirements. The DCO may also participate in a joint PDA if the Governor request this assistance. Depending on the type and severity of the disaster or emergency FEMA will activate some or all of the ESFs prescribed in the FRP.

Table 1 shows the 12 ESFs and the primary and supporting agencies for each. The ESFs are "responsible for assessing State-identified Federal assistance requirements and resource requests and to organize and direct appropriate response operations."<sup>10</sup>

DOD is the primary agency for ESF 4, Engineering and Public Works and a supporting agency for the other 11 ESF's. DOD support is provided in the context of The Robert T. Stafford Act (42 USC 5121-5203)<sup>11</sup> and DOD Directive 3025.1, Military Support to Civil Authorities.<sup>12</sup>

#	1	2	3	4	5	6	7	8	9	10	11	12
ESF												
ORG	TRANSPORTATION	COMMUNICATIONS	PUBLIC WORKS AND ENGINEERING	FIREFIGHTING	INFORMATION AND PLANNING	MASS CARE	RESOURCE SUPPORT	HEALTH AND MEDICAL SERVICES	URBAN SEARCH AND RESCUE	HAZARDOUS MATERIALS	FOOD	ENERGY
USDA	S	S	S	P	S	S	S	S	S	S	P	S
DOC		S	S	S	S	S	S			S		
DOD	S	S	P	S	S	S	S	S	S	S	S	S
DOEd					S							
DOE	S		S		S		S			S		P
DHHS			S		S		S	P	S	S	S	
DHUD						S						
DOI		S	S	S	S	S				S		
DOJ					S			S		S		
DOL			S				S		S	S		
DOS	S									S		S
DOT	P	S	S		S	S	S	S	S	S	S	S
TREAS					S							
VA			S			S	S	S				
AID								S	S			
ARC					S	P		S			S	
EPA			S	S	S			S	S	P	S	
FCC		S										
FEMA		S		S	P	S	S	S	S	S	S	
GSA	S	S	S		S	S	P	S	S	S		S
ICC	S											
NASA					S							
NCS		P			S		S	S				S
NRC					S					S		S
OPM							S					
TVA	S		S									S
USPS	S					S		S				

**LEGEND**

P - Primary agency responsible for management of the ESF.

S - Support agency responsible for supporting the primary agency.

ESF - Emergency support function.

ORG - Organization.

**TABLE 1**

**EMERGENCY SUPPORT ASSIGNMENT MATRIX  
( FM 100-19 )**



The FEMA regional office responsible for the geographic area of the disaster establishes a regional operations center and deploys advanced elements of an emergency response team (ERT). In some cases if there is prior warning of an impending disaster the ERT may already be on site. The ERT establishes the disaster field office (DFO) which is the focal point of federal response activities in the disaster area.

As shown in TABLE 1, the Department of Health and Human Services (DHHS) is the lead agency for ESF 8. The supporting agencies for ESF 8 are also shown in TABLE 1. DHHS's response is directed by the Assistant Secretary for Health who also heads the Public Health Service (ASH, HHS/PHS). The Office of the Assistant Secretary for Health/Office of Emergency Preparedness (OASH/OEP) is the action agent within DHHS and coordinates the establishment and provision of services under ESF 8. The functional areas of ESF 8 are shown below:

1. Assessment of health / medical needs
2. Health surveillance
3. Medical care personnel
4. Health / medical equipment and supplies
5. Patient evacuation
6. In-hospital care
7. Food / drug / medical device safety
8. Worker health / safety
9. Radiological hazards
10. Chemical hazards
11. Biological hazards
12. Mental health
13. Public health information
14. Vector control
15. Potable water / wastewater and solid waste disposal
16. Victim identification / mortuary services

The NDMS is a key component of federal disaster assistance. OASH/OEP (DHHS) is responsible for the program in peacetime. DOD assumes control of the NDMS during wartime. The program is a partnership between DHHS, the Department of Veteran Affairs, and DOD. Its purpose is to “provide emergency medical assistance to States following a catastrophic disaster or other major emergency...NDMS has two primary missions:

1. to supplement State and local medical resources during major domestic natural and man made catastrophic disasters and emergencies; and
2. to provide backup medical support to the Department of defense (DOD) and the Department of Veterans Affairs (VA) medical systems in providing care for U.S. Armed Forces personnel who become casualties during overseas conventional conflicts.”<sup>13</sup>

In the context of domestic disaster assistance operations NDMS’s primary objectives include:

1. “to provide health, medical, and related social service response to a disaster area in the form of medical response units or teams and medical supplies and equipment;
2. To evacuate patients who cannot be cared for in the affected area to designated locations elsewhere in the nation; and
3. to provide hospitalization in Federal hospitals and a voluntary network of non-Federal acute care hospitals that have agreed to accept patients in the event of a national emergency.”<sup>14</sup>

NDMS meets objective one through provision of health and medical personnel via Disaster Medical Assistance Teams (DMAT) and personnel from DOD, VA, and DHHS. The DMAT are composed of volunteers who are called to federal service when the DMAT are activated. OASH/OEP administers the DMAT program. In an emergency, the DMAT are called to federal service and deployed by an OEP Operations Support Center which is responsible for

“overall control of DMAT utilization.”<sup>15</sup> The federalization process allows the medical personnel to provide services outside of the State in which they are licensed or certified.

DMAT are generally composed of between 35-100 medical personnel. Most DMAT are designed to provide emergency medical or primary care services. Various specialty DMAT exist for special circumstances. The DMAT in the field are usually supported by a Management Support Unit (MSU) which provides logistical and administrative support. After federalization, DMAT are typically transported to disaster areas by DOD aircraft.

The second component of the NDMS in disaster operations is the casualty evacuation system. When activated the casualty evacuation system transports patients from the disaster area to other locations for medical care. This portion of the NDMS is administered through DOD. The Joint Medical Regulating Office tracks the patients and the Air Force provides the aircraft. Theoretically, the Civilian Reserve Air Fleet can be activated to supplement United States Air Force (USAF) aircraft, although the time required to activate and outfit commercial aircraft for medical evacuation would mitigate against their use except in the direst of circumstances.

The final component of NDMS is a network of acute care hospitals which have agreed to provide beds for victims. The network includes DOD and VA hospitals and volunteer civilian facilities. Over 110,000 beds are currently committed to NDMS in over 1800 participating hospitals. This number does not include the VA and DOD beds which are also available.<sup>16</sup>

## HURRICANE ANDREW

On 20 August, even as Tropical Storm Andrew meandered about the Caribbean, the first preparatory briefings were held at the FEMA Region VI headquarters to insure that FEMA was prepared should the storm increase in intensity and turn toward the coast. On 22 August a hurricane watch was issued and units of the Florida Army National Guard (FLARNG) were mobilized.<sup>17</sup>

In Washington, also on the 22nd, the Acting Assistant Secretary of Health, DHSS was briefed and the NDMS was alerted. An advanced element of a FEMA ERT arrived in Tallahassee while the advanced elements of a DMAT MSU arrived in Dade County. Ten DMAT teams from around the country were alerted for possible federal service and deployment.<sup>18</sup>

Hurricane Andrew, a category 4 hurricane, made landfall 35 miles south of Miami, Florida at 0445 hours on 24 August 1992. Sustained winds of 145 miles per hour with gusts up to 164 miles per hour were recorded. The hurricane force winds extended 45 miles from the center of the storm. A tidal surge of 19.6 feet was recorded. The storm moved west-northwest across the state at an average speed of 18 miles per hour leaving in its wake a path of destruction, the true extent of which would not be known for several days. Andrew entered the Gulf of Mexico south of Naples, Florida and continued its path across the Gulf, significantly weakening before striking the Louisiana coast.<sup>19</sup>

Hurricane Andrew was "the worst natural disaster ever to hit the United States. Andrew's nearly \$30 billion in total damages quadrupled the previous \$ 7 billion record set by Hurricane Hugo in 1989."<sup>20</sup> Andrew's toll was enormous. Thirty-two deaths were associated with the

storm. Fourteen accidental deaths were directly related to the storm while the remainder were indirectly related.<sup>21</sup> Three hundred thousand jobs were lost, 8000 businesses destroyed, and 32,000 acres of farmland were ruined.<sup>22</sup> Over 100,000 homes were destroyed or damaged with over 250,000 people left homeless or with inadequate shelter.<sup>23</sup> By any measure Hurricane Andrew was a catastrophe of major proportion.

Within hours after the storm crashed ashore, FEMA / NDMS activated the first two DMAT and requested DOD aircraft for transport. By 25 August these two teams were operational. Over the course of the next several weeks 16 DMAT and a fully functional MSU consisting of approximately 460 persons were ultimately deployed.

The chaos left in the wake of the storm hampered disaster assessment efforts. By the second day FEMA officials recognized that a massive federal response would be required but the State had not yet requested support.<sup>24</sup> In fact, the same day that FEMA officials recognized the need for substantial federal involvement, a spokesman for the Florida Army National Guard (FLARNG) stated that "Florida has not requested any support from other states or federal agencies, nor do we see the need."<sup>25</sup> The same day that the FLARNG claimed that no external assistance was needed, the Dade County Emergency Operations Director assailed the lack of assistance with the question, "Where in the hell is the cavalry? For God sake's, where are they?... We need food, we need water, we need people down here."<sup>26</sup>

## **DOD RESPONSE**

As Hurricane Andrew bore down on the coast of Florida and in accordance with the 2nd Continental US Army's (CONUSA) Military Assistance to Civil Authorities Plan, a Defense

Coordinating Officer (DCO) had already been appointed. The DCO is responsible for coordination with the FCO. In addition an Emergency Response Team from the 2nd CONUSA was transported to Tallahassee on the 23rd of August. At 1300 on 24 August, President Bush declared South Florida a Federal Disaster Area. This declaration set in motion the chain shown in Figure 1. FEMA notified Directorate of Military Support (DOMS) of the Disaster Declaration at 1530 and the Secretary of the Army issued an execute order at 1610 for DOD support.<sup>27</sup>

The Secretary directed the Commander in Chief, US Army Forces Command (CINCFOR) to function as the operating agent for DOD in providing disaster relief. At 2130 on 24 August, CINCFOR ordered the 2nd CONUSA to execute. At 1740 on the 27th of August, the President ordered increased DOD support as more complete damage assessments were concluded. CINCFOR established Joint Task Force Andrew (JTFA), under the command of LTG Ebbesen, Commander, 2nd CONUSA. General Ebbesen collocated the JTF headquarters with FEMA's DFO at the Miami International Airport.<sup>28</sup>

## **JOINT TASK FORCE ANDREW**

The mission of JTFA "was to provide humanitarian support by establishing field feeding sites, storage / distribution warehousing, cargo transfer operations, local / line haul transportation operations, and other logistical support to the local population."<sup>29</sup> The JTF commander directed immediate priority to providing feeding and water facilities to the Homestead, Florida City, and the Cutler Ridge Area. Support was to be expanded into other stricken areas as more definitive damage assessments became available. The end state of the operation was specified as "get(ing) life support systems in place and relieve(ing) initial

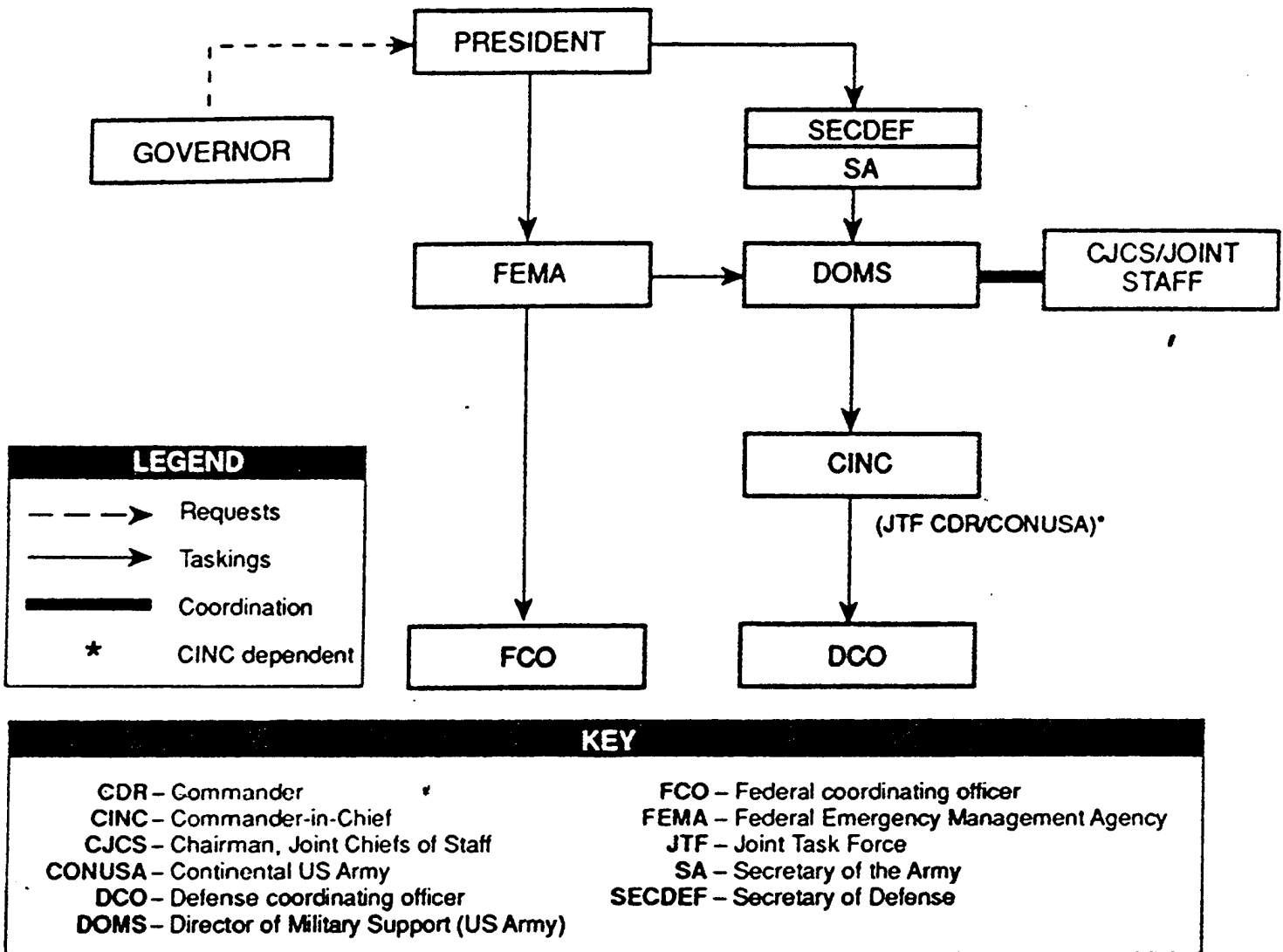

**FIGURE 1**  
**DECISION SEQUENCE for DOMESTIC DISASTER SUPPORT**  
 (FM 100-19)

hardships until non-DOD, State, and local agencies can reestablish normal operations throughout the AO (area of operations).<sup>30</sup> The concept of operations eventually reflected the currently accepted doctrinal division of domestic disaster assistance into three phases, Relief, Recovery, and Reconstitution.<sup>31</sup> The current doctrine is a direct result of the lessons learned in South Florida.

CINCFOR alerted Headquarters, XVIII Airborne Corps to prepare for deployment to provide increased support at 1300 on 27 August. Initial deployments began the same day. On 30 August, Headquarters, XVIII Airborne Corps was ordered to deploy as the Army Forces (ARFOR) element of JTFA. Task Force (TF) All American (elements of the 82nd Airborne Division) was assigned to the Cutler Ridge portion of the area of operations (AO) while TF Mountain (elements of the 10th Mountain Division) was assigned an AO which included Homestead, Florida City, and Leisure City. The Task Forces were heavily augmented with attached combat support and combat service support elements.<sup>32</sup> The influx of massive federal assistance as directed by the FRP allowed the FLARNG to redirect its focus towards law enforcement throughout the stricken area. The FLARNG, not being federalized, was not limited by Posse Comitatus restrictions. The State control of the Guard enabled the Guardsmen to be used for law enforcement. The Posse Comitatus statute prohibits the use of federal military in law enforcement roles. Figure 2 shows the organization of JTFA.<sup>33</sup>



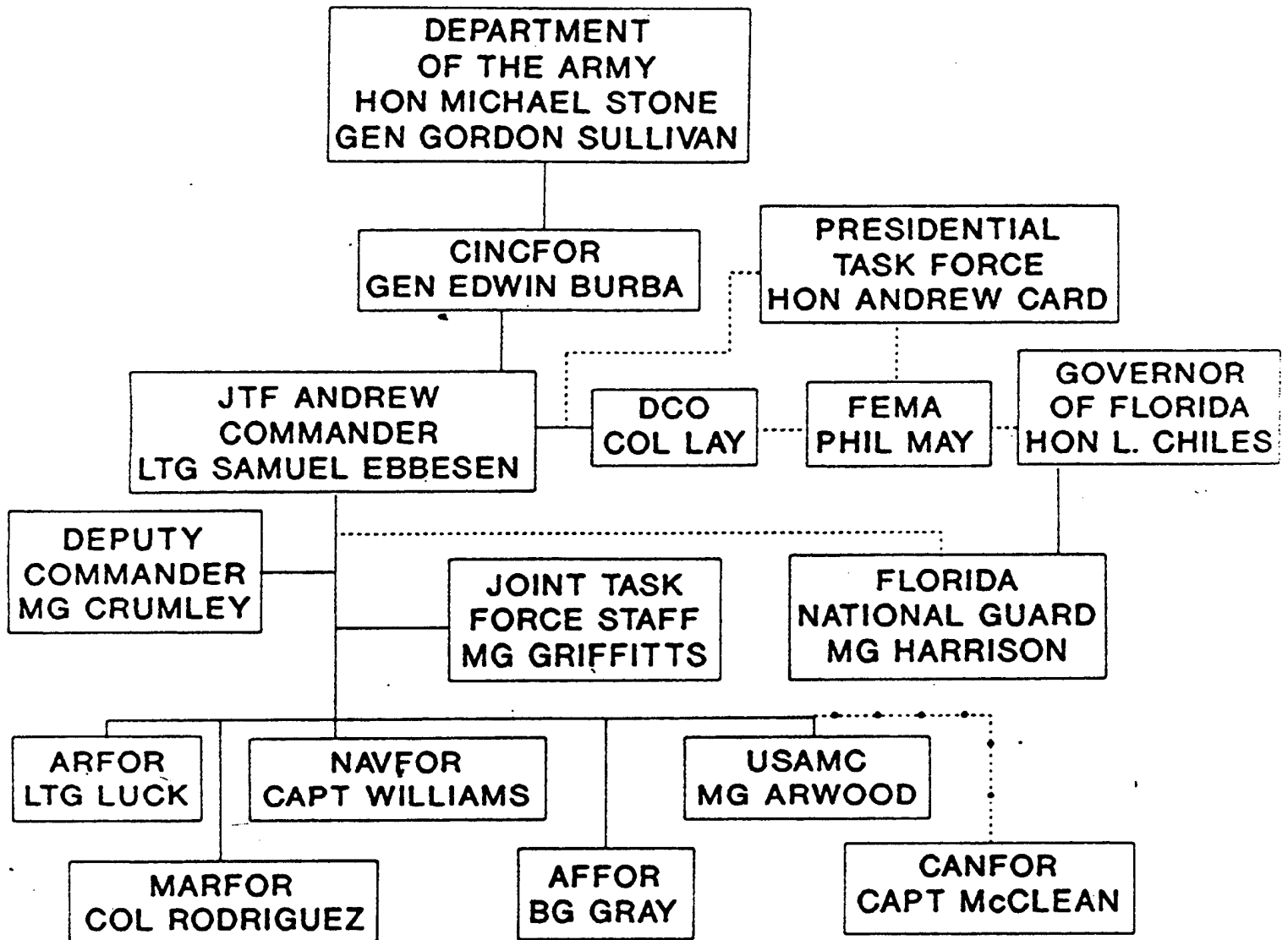

FIGURE 2

JOINT TASK FORCE ANDREW ORGANIZATION

## **The AMEDD Role**

Reserve Component (RC) medical units provided the initial military medical response to Hurricane Andrew. FLARNG medical units were the first military medical units to arrive in the AO.<sup>34</sup> The 301st Rescue Squadron of the USAF Reserve began flying medical evacuation missions on the 25th of August.<sup>35</sup>

The 44th MED BDE is one of Forces Command's major medical units. Headquarters, 44th MED BDE is located at Ft. Bragg, NC and is mission-capable of providing corps medical support. Its subordinate units are capable of providing medical care at echelons II- III, ground and air evacuation, dental, veterinary, preventive medicine, combat stress and medical logistic support. Echelon II care consists of care provided by a team of health care providers. Level III care denotes a level of care typically provided in a medical treatment facility (MTF).

Personnel from the 44th MED BDE (a health care operations officer and an environmental science officer) were part of the initial assessment team that were deployed to South Dade on August 27. The medical concept of operations and the commander's intent were based, in large measure, on the information provided by the assessment team. The Commander, 44th MED BDE, was also in contact with the federal medical relief effort coordinator who had been on the ground in Miami when the hurricane struck. This individual had been designated at the request of the President as the coordinator for all federal medical relief efforts. The federal medical relief coordinator was a United States Public Health Service Officer (USPHS), CAPT. Gray.

The preliminary disaster assessments (PDA) from CAPT Gray and his assessment team and the separate XVIII Airborne Corps assessment team indicated that there were relatively few

major trauma casualties. The major hospitals in Miami and North Dade County had weathered the storm without major damage and were able to accept trauma patients from South Dade who were transported by the Dade County Emergency Medical Services, which continued services throughout the crisis period. The medical units of the 44th MED BDE are designed primarily to provide surgical care to combat casualties. With the knowledge that major trauma care would not be required and with the implicit mission of providing direct health care to the population of the devastated area, BG Peake therefore task organized his medical units to augment their primary care capabilities.

Based on the PDA, which reported major disruption of public health and sanitation infrastructure and catastrophic damage to health care facilities in the area, BG Peake also task organized his forces to include major Preventive Medicine (PM) assets. He also recognized the requirement for augmentation of his staff with subject matter experts in fields such as health facility engineering, solid waste management, water system design, veterinary medicine, public health and mental health. He requisitioned officers from Health Services Command and attached them to the Brigade Headquarters, Forward (FWD).

The first echelon of the 44th MED BDE arrived at Opa Locka Coast Guard Air Station on 28 August. This echelon consisted of elements of the 28th Combat Support Hospital (CSH), primary care medical assets, and PM units. The JTFA Surgeon's Office was established on 29 August.<sup>36</sup> BG Peake was designated as TF Surgeon. The personnel of the 44th MED BDE Headquarters (FWD) functioned as the JTFA Surgeon's staff. Figure 3 shows the organization of the JTFA Surgeon's Office, while Figure 4 shows the organization of the Army medical assets deployed to provide health and medical support.

FIGURE 3

ORGANIZATION OF JTFA SURGEON'S OFFICE

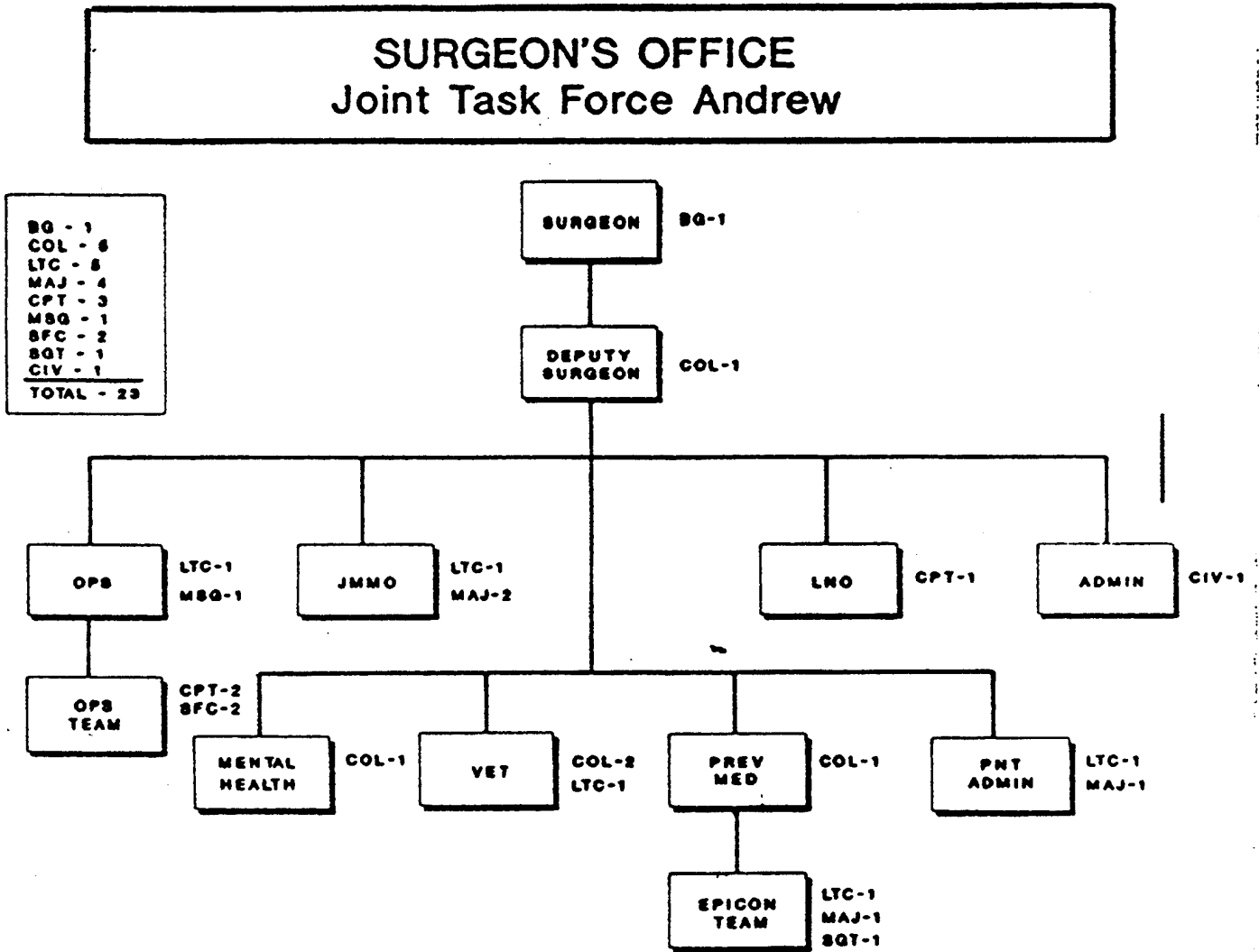
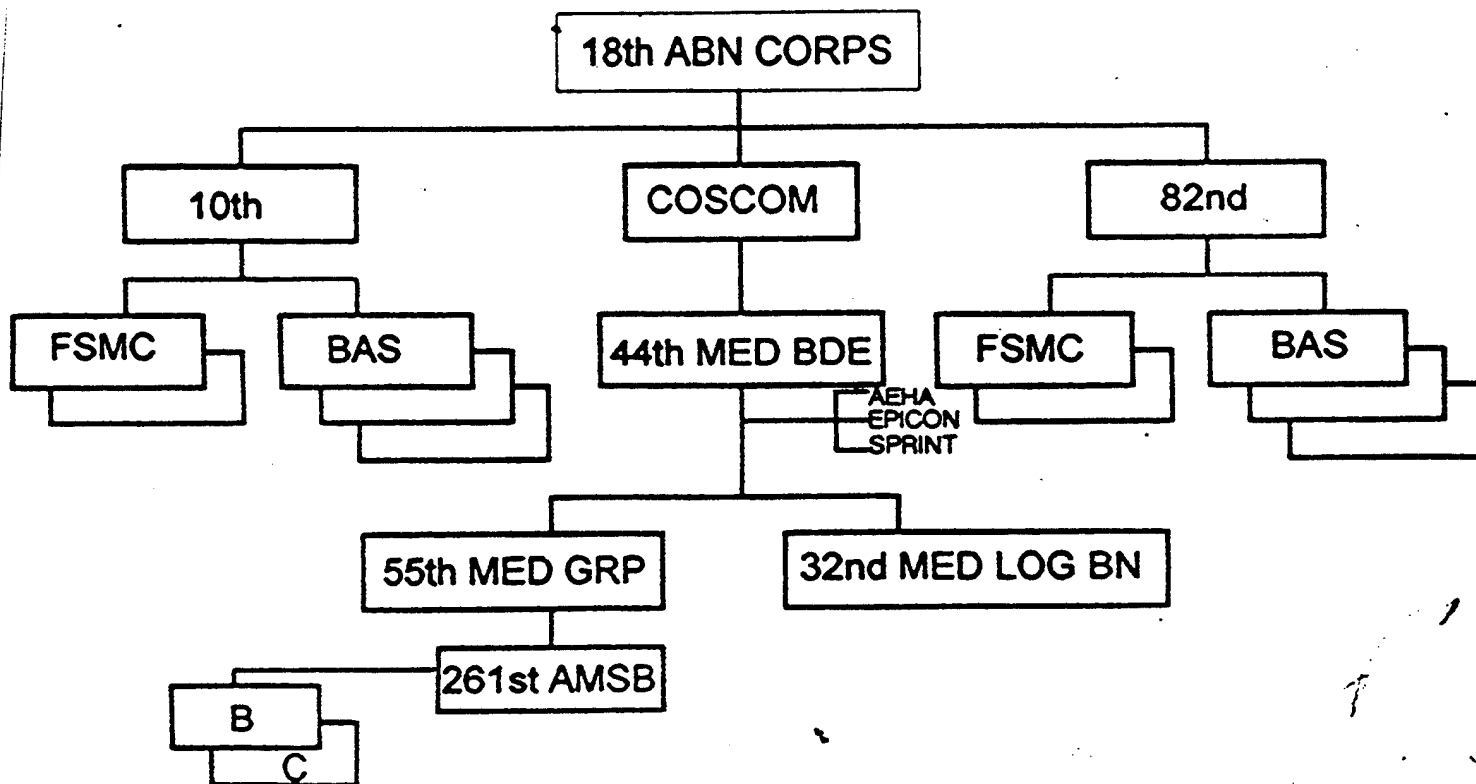

FIGURE 4

ORGANIZATION OF ARMY MEDICAL SUPPORT - JTFA



The Surgeon's office was established in the South Dade County Government Center which also housed the NDMS MSU. The collocation of the Surgeon's Office and the MSU facilitated the coordination of the two major providers of health and medical care in the disaster area. The collocation also facilitated the development of the Health and Medical Task Force (HMTF).

This HMTF was convened to coordinate the organization, prioritization, and provision of health and medical services by the numerous health care providers active in the AO. The HMTF met daily at the South Dade Government Center and was crucial to the successful employment of medical assets. Co-chaired by CAPT Gray and BG Peake, the HMTF is the medical analog of Civil-Military Operations Center (CMOC) and contributed immeasurably to unity of effort, one of the tenets of peace operations.<sup>37</sup> Membership on the HMTF included representatives from DOD; Federal non-DOD; State, City, and County; health and medical organizations such as medical and dental societies; nursing, veterinary and hospital associations; other non governmental organizations (NGO) such as the American Red Cross and the Salvation Army; and private voluntary organizations (PVO).

The original DOD medical mission was to provide health care to deployed forces. After the President's direction for increased DOD support on August, 27 and directions from the Chief of Staff, United States Army during his visit to Ft. Bragg the implicit mission of providing direct medical care to the population in the disaster area was added.<sup>38</sup> BG Peake then developed the following objectives:

to conduct "immediate relief operations to meet critical health care needs to prevent morbidity and mortality" followed by a focus on "assisting in the initial reestablishment of the devastated area's health care infrastructure in conjunction with State, county, and other Federal agencies."<sup>39</sup>

The concept of medical operations stressed "overwhelming force". Medics from TF All-American and TF Mountain provided "tail gate" medical care while division medical elements established medical treatment facilities (MTF) in the TF AO's. Corps level medical units established MTF at several of field feeding sites and life support centers (LSC). The LSC were "tent cities" erected to provide shelter to the homeless. Area medical support was also provided by two companies from the 261st Area Support Medical Battalion, 44th MED BDE, and two companies of the FLARNG.

The 28th CSH established a hospital and an emergency room adjacent to the Homestead (city) hospital. Medical personnel from the United States Marine Corps, Special Purpose Marine Air Ground Task Force (SPMAGTF) established a clinic with a small holding capacity at the largest of the LSC. Area support was provided by ground evacuation assets.

Preventive medicine units provided area support while division level PM assets focused on the division AO. Initial PM efforts focused on provision of potable water, quality of food service sanitation and general sanitation. Vector surveillance and control were secondary missions during the initial phase. Subject matter experts in disease surveillance, solid waste management, and water system design augmented the PM cell at the JTFA Surgeon's Office. United States Navy (USN) Disease Vector Control elements provided area support and USAF Reserve aircraft performed aerial mosquito spray missions. A PM / Public Health Coordination

committee was established to coordinate the activities of the numerous PM / Public Health teams from DOD, Federal Non-DOD, State, County, and local sources.

Mental health support was provided through division level mental health teams who assessed neighborhoods in order to facilitate early intervention by State mental health assets. A US Navy Special Psychiatric Rapid Intervention Team complemented Army mental health activities.

The 32nd Medical Logistics (MEDLOG) Battalion established a Class VIII (medical) supply depot in North Miami. The battalion controlled and organized the massive medical supply donations that flowed into South Dade County. The supplies were distributed with the support of FLARNG transportation assets to MTF operated by the VA, DOD, NDMS, local governments and NGO and PVO.

Dental care and veterinary support was provided in coordination with the local dental and veterinary organizations. A health facility engineer attached to the Surgeon's Office provided rapid and comprehensive assessments of many of the damaged and destroyed health care facilities throughout the area.

## **LESSONS LEARNED**

The thirty-five medical JULLS listed in the JTFA Surgeon's After Action Report Executive Summary are shown at Appendix 1.<sup>40</sup> For purposes of this research the JULLS have been divided into four categories. Category I includes those JULLS for which no evidence of significant action has been identified from this research. Category II are those JULLS for which the research indicates that actions have been completed or substantially completed. Category III



includes those JULLS which have been partially addressed and require further action. Category IV includes JULLS that can be considered informational only. This category includes those JULLS for which "the fix" was within the capacity of the 44th MED BDE to implement. It also encompasses those JULLS which basically represented a true lesson learned, e.g. "We will not make that mistake again!" or "This worked well and we should remember it next time!" I was unable to ascertain the status of JULLS 4, CTA 50-90 for the Navy Sprint Team.

#### *Category I*

JULLS 11 called for the development of doctrine to direct mental health support for domestic disasters. Discussions with the Office of the Assistant Commander for Force Integration, AMEDD Center and School (AMEDD C&S) indicates that there is currently no approved doctrine for mental health support to domestic disasters.<sup>41</sup> The Mental Health Staff Officer attached to the JTFA Surgeon's Office has published a report which covers in great detail the actions of the mental health assets in support of disaster assistance operations in South Dade County.<sup>42</sup> This publication could be utilized as a template for future mental health disaster support operations.

#### *Category II*

JULLS 1 calls for the designation of a Joint Surgeon during DSO and alludes to the importance of each component's designation of a Surgeon. *Doctrine for Health Service Support in Joint Operations*, Joint Pub 4-02, calls for the designation of a Joint Surgeon and discusses the importance of the Joint Surgeons' coordination with component Surgeons.<sup>43</sup> The importance of early deployment of PM assets for disaster and humanitarian assistance operations (JULLS

10) is also addressed in Joint Pub 4-02.<sup>44</sup> This publication also provides the framework for joint operating instructions (JULLS 18).

JULLS 13 stresses the need for coordination of veterinary support and the importance of the veterinary staff officer who was attached to the Surgeon's Office. A veterinary staff officer can readily be requisitioned and attached to the JTF Surgeon's Office if required in future operations. JULLS 14 addresses Veterinary support doctrine. The AMEDD C&S has not developed veterinary doctrine to respond to JULL 14.<sup>45</sup> However, the National Veterinary Medical Association has developed a comprehensive disaster support plan to provide veterinary support in future disasters.<sup>46</sup>

### *Category III*

JULLS 3 stresses the need for training and doctrine in disaster assistance operations. The AMEDD C&S, as noted above, has not developed a medical doctrine for disaster assistance operations nor has it instituted any disaster specific training nor has it developed a doctrine for assessing medical care delivery capabilities.<sup>47</sup> However, the 44th MED BDE has instituted internal training in these areas.

JULLS 12 addresses the need for training on FEMA and NDMS organization and operations while JULLS 16 concerns the need for training in the FRP and ESF. The 44th has addressed these concerns in its internal training. JULLS 20, appropriate taskings in accordance with the FACP., was addressed in the 44th exercises. It was also discussed in the NDMS Demobilization Debriefing held in November 1992, which was attended by representatives from all agencies which provided health and medical support.<sup>48</sup>

The medical logisticians have responded to the need to address the unique medical supply requirements for disaster operations (JULLS 17).<sup>49</sup> In my opinion, the Humanitarian Augmentation Package developed by the logisticians provides an adequate array and quantity of Class VIII supplies for domestic disaster operations. The DOD logistics role in the support of DMAT (JULLS 22) was addressed in the NDMS Demobilization Conference.<sup>50</sup>

The importance of coordination between DOD medical assets and civilian health care institutions stressed in JULLS 23 and the need for a task force for organizing and prioritizing public health reconstitution (JULLS 9) is demonstrated by the success of the HMTF described above. The link between the HMTF and the doctrinal CMOC has been noted. The Army has utilized similar DOD - NonDOD coordinating cells in other humanitarian and peacekeeping operations.

The requirements for improved joint aeromedical evacuation operations (JULLS 27) was addressed in Joint Pub 4-02.<sup>51</sup> JULLS 29 concerns the need for providing alternative MTF for DOD health care beneficiaries when their primary source of DOD health care is rendered inoperable secondary to a disaster. The new TRICARE contracts being established to complement the DOD direct care system will insure a network of health care sources for beneficiaries which can be activated during periods when DOD direct care is not available.

JULLS 32 addresses the use of FEMA communications equipment in medical command and control. Leased cellular telephones were the primary means of communication among the medical elements until the FEMA satellite communications system came on line.

Communications was discussed at the NDMS Demobilization Conference although I can find no evidence that a fix has, in fact, been made. Medical units have traditionally lacked adequate

communications capabilities. This need has been recognized and is being addressed in the medical re-engineering initiative.<sup>52</sup> The development of telemedicine capabilities within the medical units will contribute to the ability of the medical commanders, their staffs, and their providers to communicate within the AO and external to the AO.

Interagency medical reporting (JULLS 33) refers to the need for a common system of health care reporting. A common system would enhance disease and injury surveillance efforts and simplify the documentation of patient encounters. Epidemiologists from the Centers for Disease Control and Prevention and Army epidemiologists collaborated on medical surveillance during the Hurricane Andrew relief operations. Although they did not agree upon identical reporting criteria they were able to collect compatible information.<sup>53</sup> No consensus has been obtained on a standard medical reporting criteria among other Federal and non-Federal providers. The importance of standard reporting formats was discussed at the NDMS Demobilization Debriefing.<sup>54</sup>

AR 600-110, Identification, Surveillance, and Administration of Personnel Infected with the Human Immunodeficiency Virus (HIV) requires reserve personnel on active duty for longer than 30 days to have a valid HIV test within the previous 6 months.<sup>55</sup> This requirement complicated the utilization of US Army Reserve (USAR) soldiers during the disaster relief activities. JULLS 34 stresses the importance of amending this requirement or providing for HIV testing for USAR soldiers during domestic support operations. AR 600-110 has not been changed to address these concerns; however discussions are currently ongoing regarding possible changes in the HIV testing requirement for RC personnel.<sup>56</sup>

*Category IV*

The following JULLS address organization, personnel, and / or command and control issue. JULLS 5 and 6 concern the importance of health facility engineer support. The lack of a health facility engineer on the Brigade Staff was remedied by the attachment of an engineer from the Health Facility Planning Agency. The need for task organizing physician specialty staffing in disaster operations is addressed in JULLS 8. The flexibility to task organize the medical assets to be deployed is inherent in the commander's authority. The changes in the medical force structure being considered in the Medical Re-engineering Initiative will result in more flexible medical units that can be readily tailored to the operation.<sup>57</sup> JULLS 35 stresses the need for epidemiological support which was provided by the attachment of a team from the Walter Reed Army Institute of Research.

JULLS 21 (JTF Surgeon's Office Staffing and Organization); automation requirements for the Surgeon's Office (JULLS 25); and JULLS 26 (the importance of communications to the functions of the Surgeon's Office) were addressed in the JTFA Surgeon's After Action Report. A notional Surgeons' staff (Figure 5) was proposed as was necessary automation and communications equipment.<sup>58</sup>

JULLS 2 and 28 stress the importance of the Surgeon's control over the deployment of medical assets to the AO and operational control or coordination of all medical elements in the AO. JULLS 30 and 31 discuss problems that arose by virtue of the establishment of the LSC. No provisions for care of pets had been made and many persons who were not bonafide LSC residents attempted to obtain medical care at LSC MTF.

The importance of determining the long term primary care requirements of the disaster area (JULLS 15) relates to the importance of early identification of the desired end state. The importance of identifying an end state is another tenet of peace operations.<sup>59</sup> This was complicated in South Dade County due to the inadequate level of primary care in the area prior to the disaster.

JULLS 19 concerns the need for a JTFA medical report. In future operations the JTF Surgeon should insure that a standard JTFA Medical Report is utilized. The need to provide sickcall support for headquarters personnel (JULLS 24) actually addresses the need to provide sick call at the JTF Headquarters, which, in the case of JTFA, was located at the Disaster Field Office (DFO). This JULL is situation-dependent. Had the JTFA Surgeon's Office been collocated with the JTFA Headquarters and the DFO, sickcall support would have been present. A "clinic" was established at the DFO when the medical assets in the AO permitted the attachment of personnel to the DFO. JTF Surgeons should ensure that sickcall support is provided to the JTFA Headquarters element if the Surgeon's Office and the Headquarters are not collocated.

FIGURE 5

NOTIONAL TASK FORCE SURGEON'S OFFICE

**PROPOSED SURGEON'S OFFICE**  
Future Joint Task Force Operations

BG	- 1
COL	- 8
LTC	- 9
MAJ	- 9
SOM	- 1
MSG	- 1
SFC	- 2
SGT	- 8
CIV	- 1
<hr/>	
TOTAL	- 34

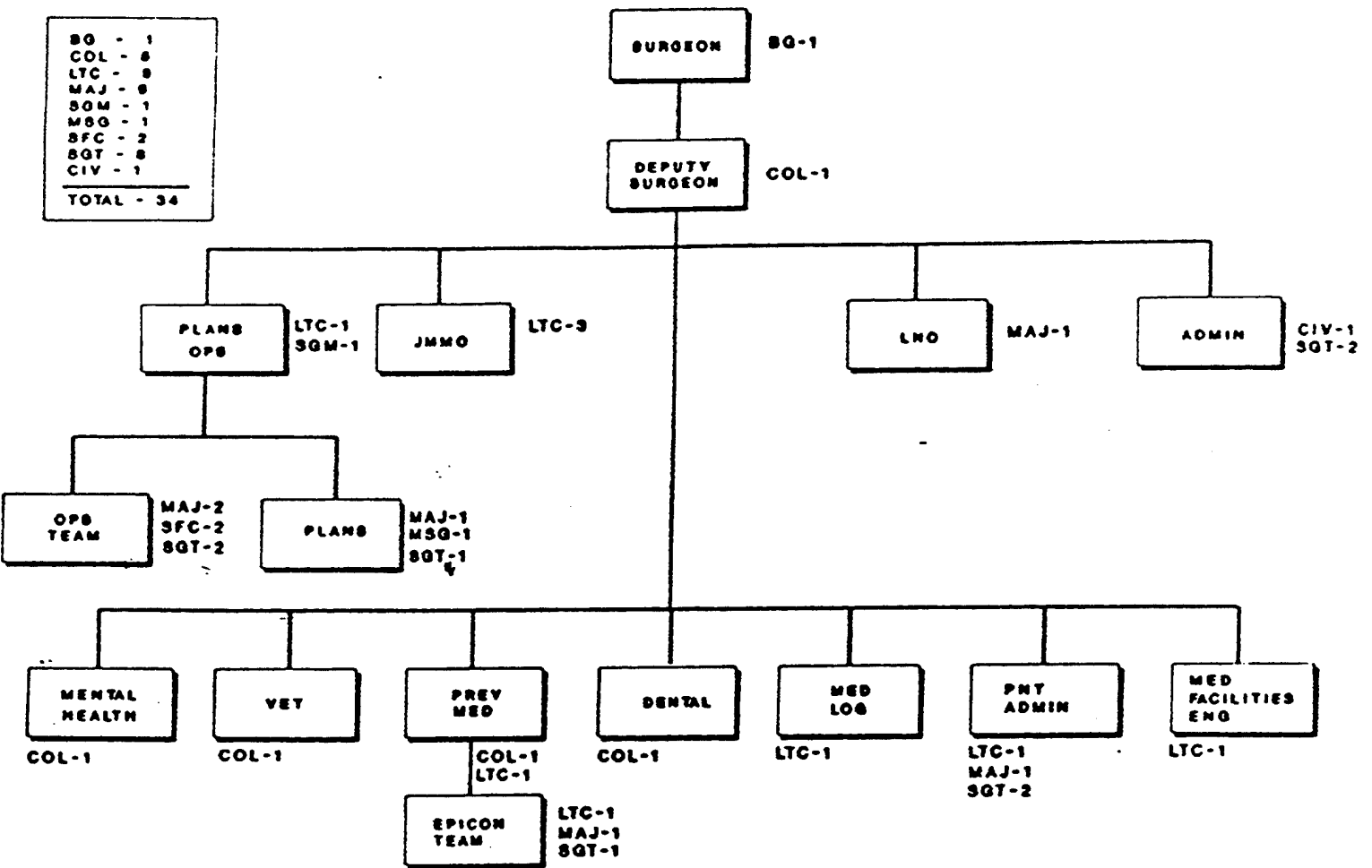

## CONCLUSION

The AMEDD's contribution to the Hurricane Andrew disaster relief operations was significant and key to the successful completion of the mission. Over 20,000 patients were treated at military MTF.<sup>60</sup> Division medics cared for many thousands more patients with minor problems. Health facilities were inspected; animals, small and large, cared for; mental health teams searched the devastated neighborhoods for persons in need of help. Tons of medical supplies were distributed. PM teams tested hundreds of water samples, performed hundreds of food service sanitation inspections, dozens of LSC inspections, hundreds of insect surveys and dozens of insect treatments. They also performed infectious disease and epidemiological surveillance.

The keys to effective AMEDD disaster response include a rapid comprehensive assessment of the disaster area; an understanding of the complexities of the FRP, with emphasis on ESF 8; coordination with other providers of health and medical services; and early determination of the desired end state. AMEDD personnel should be included in the initial disaster assessment team. The team should contain AMEDD personnel with expertise in emergency medicine, PM, facility engineering, health care operations and logistics. It is important for the team members, especially clinician team members, to remember that the "medical responsibility in catastrophe differs radically from the routine. The philosophy of care no longer centers on the individual patient. Medical resources, personnel, supplies and facilities are carefully allotted to provide the greatest good for the greatest number."<sup>61</sup>

The comprehensive assessment is followed by a prioritization of health and medical care needs. Medical assets can then be tailored to meet these needs most effectively. It must be



remembered that no two disasters are exactly alike. The health and medical care needs for an earthquake will differ significantly from that required for Hurricane Andrew. The requirements for Hurricane Andrew would have been dramatically different if the storm had made landfall 25 miles north in Miami.

Effective disaster response is a classical interagency exercise. AMEDD leaders in disaster scenarios must understand the FRP and their duties under ESF 8. The AMEDD C&S should familiarize AMEDD commanders with disaster operations during the AMEDD Pre-Command Courses. Commanders should attend or send a representative to the Department of Defense Emergency Preparedness Course or the annual NDMS conference, Delivering Health and Medical Services in Catastrophic Disasters.

The importance of coordination with local and state agencies, NGO's and PVO's, and non-DOD agencies cannot be overemphasized. The HMTF, which met daily in South Dade County, was one of the keys to the successful transition of health and medical operations to non-DOD control. Early identification of the desired end-state is crucial to successful transition. Each action must be considered in the context of its' impact on achieving the desired end-state. Although the AMEDD units in the AO may have the capability to perform a given mission does not mean that the mission should be performed by the AMEDD. The performance of the mission by non-AMEDD organizations may be critical to successful transition.

Strategy may be considered the application of ways and means to achieve specified ends. In the context of a disaster scenario strategy, the end is successful transition to local and state control. The FRP; DOD Directive 3025.1; DOD Manual 3025.1-M, Manual for Civil Emergencies; FM 100-19, Domestic Support Operations; and the soon to released

Joint Pub 3-07.7, Joint Tactics, Techniques, and Procedures for Domestic Support Operations

are the ways. The means are based on the disaster assessment which allows the commander to

tailor the medical forces to the unique requirements of each disaster operation. Training of

AMEDD commanders in disaster operations and coordination of ways and means with local and

state agencies facilitates the combination of the ways and means to achieve the desired end.

## APPENDIX 1

### JOINT UNIFORM LESSONS LEARNED (MEDICAL)

UNCLAS

#### JULLS TITLE LISTING

JULLS NO.	NICKNAME	TITLE
91749-17995 (00001)	DISASTER RELIEF	Designation of Command Surgeons
91753-53802 (00002)	DISASTER RELIEF	Preventive Medicine Task Force Augmentation - Excess Capability
91754-09155 (00003)	DISASTER RELIEF	Training Requirement for Disaster Relief Operations Doctrine
92143-45040 (00004)	DISASTER RELIEF	CTA 50-90 for Navy Sprint Teams
92144-01893 (00005)	DISASTER RELIEF	Health Facilities Assessment/Assistance
92147-09547 (00006)	DISASTER RELIEF	Requirement for Health Facilities Assessment and Assistance Team/Detachment
92151-65154 (00007)	DISASTER RELIEF	Doctrine for Assessing Medical Care Delivery Capabilities
92154-17120 (00008)	DISASTER RELIEF	Physician Specialty Requirements for Humanitarian Relief
92156-41177 (00009)	DISASTER RELIEF	Task Force For Organizing and Prioritizing Public Health Reconstitution
92160-11452 (00010)	DISASTER RELIEF	Early Deployment of PM Detachments For Humanitarian Relief
92160-56524 (00011)	DISASTER RELIEF	Doctrine for Mental Health Detachments Supporting Civilian Disasters
92161-23390 (00012)	DISASTER RELIEF	Instruction on FEMA and MDMS Organization and Operations
92161-82127 (00013)	DISASTER RELIEF	Veterinary Support Coordination
92163-77904 (00014)	DISASTER RELIEF	Veterinary Support Doctrine
92164-35900 (00015)	DISASTER RELIEF	Long-term Primary Care Requirement in Disaster Relief Operations
92164-81883 (00016)	DISASTER RELIEF	Federal Response Plan and Emergency Support Functions (Instruction)
92165-66771 (00017)	DISASTER RELIEF	Medical Supply Requirements for Disaster Relief Operations
92229-91440 (00018)	DISASTER RELIEF	Availability of Joint Operating Instructions
92230-36204 (00019)	DISASTER RELIEF	JTFA Medical Reports
92230-91074 (00020)	DISASTER RELIEF	Tasking IAW Federal Disaster Response Plan
92231-34356 (00021)	DISASTER RELIEF	JTF Surgeon Section Staffing and Organization
92233-45165 (00022)	DISASTER RELIEF	DOD Logistics Role in DMAT Support Operations
92234-12010 (00023)	DISASTER RELIEF	JTF Coordination with Civilian Healthcare Officials
92234-47189 (00024)	DISASTER RELIEF	JTF Headquarters Sickcall
92236-23226 (00025)	DISASTER RELIEF	Automation Requirements Within Staff Sections
92236-76157 (00026)	DISASTER RELIEF	Communications
92237-18280 (00027)	DISASTER RELIEF	Joint Aeromedical Evacuation Requirements/System
92238-22144 (00028)	DISASTER RELIEF	Service Component Independent Relief Efforts Within Area of Operations
92238-65161 (00029)	DISASTER RELIEF	Medical Support for Retiree Population Located Within Disaster Area
92238-93926 (00030)	DISASTER RELIEF	Temporary Pet Boarding for LSC residents
92249-55471 (00031)	DISASTER RELIEF	Medical Care Eligibility
92336-97446 (00032)	DISASTER RELIEF	FEMA Communications Systems Supporting Medical C-2
92337-56403 (00033)	DISASTER RELIEF	Intergovernmental Agency Medical Reporting
92645-29123 (00034)	DISASTER RELIEF	HIV Testing for Reservists on AD Exceeding 30 Days
92868-60463 (00035)	DISASTER RELIEF	Epidemiological Monitoring for Disease Trends.

## ENDNOTES:

1. Thomas G. Harrison, Peacetime Employment of the Military - The Army's Role in Domestic Disaster Assistance, (Carlisle Barracks, PA: U.S. Army War College, 1992), 5.
2. Ibid., 6.
3. Ibid., 7.
4. Charles S. Clark, "Disaster Response - Does the Country Need a New National Strategy?," CQ Researcher 3, no.38 (1993): 898.
5. Federal Emergency Management Agency, "FEMA's Mission."(accessed 17 March 1996) available from <http://www.fema.gov/fema/mission.html>; Internet.
6. United States General Accounting Office (GAO), Disaster Management - Recent Disasters Demonstrate the Need to Improve the Nation's Response Strategy, (GAO/T-RCED-93-4), (Washington: United States General Accounting Office, 1993), 2.
7. Natural Hazard Center, "President Raises FEMA Director to Cabinet Level Post", Disaster Research, (accessed 15 March 1996) available from [hazards@lists.colorado.edu](mailto:hazards@lists.colorado.edu).
8. GAO, 2.
9. GAO, 4.
10. The Federal Emergency Management Agency, The Federal Response Plan (FRP). (Washington: FEMA, 1992), 24.
11. Robert T Stafford Disaster Relief and Emergency Assistance Act. U.S. Code, Vol. 42, sec. 5121 (1974).
12. Department of Defense, Military Support to Civil Authorities, Department of Defense Directive 3025.1 (Washington, 15 January 1993).
13. National Disaster Medical System (NDMS), National Disaster Medical System Strategic Vision. (Washington: NDMS, 1994), II-1.
14. NDMS, II-2.
15. NDMS, II-3.
16. NDMS, II-4.

17. Dennis Steele, "Digging Out From Despair," Army, (Nov, 1992): 23.
18. Harold M Ginzburg, Robert J. Jevic, and Thomas Reutershan, "The Public Health Service's Response to Hurricane Andrew," Public Health Reports, 108, no. 2 (1993): 243.
19. Centers for Disease Control (CDC), "Preliminary Report: Medical Examiner Reports of Deaths Associated with Hurricane Andrew - Florida, August 1992", Morbidity And Mortality Weekly Report, 41, no.35 (1992): 641.
20. Clark, 891.
21. CDC, 642.
22. Clark, 902.
23. Thomas B. Arwood, " The Quartermaster and Humanitarian Support Missions," Quartermaster Professional Bulletin (Spring 1995): 5.
24. GAO, 5.
25. Judith M. Anderson, "Hurricane Andrew - Coping with Medical Wipeout," MD (November 1992): 24.
26. Ibid.,
27. Joint Task Force Andrew (JTFA), "Overview Executive Summary," Joint Task Force Andrew After Action Report, (Miami: Federal Emergency Management Office - 955, 15 October 1992), 2-3.
28. Ibid.,
29. Ibid.,
30. Ibid., 4.
31. Department of the Army. Domestic Support Operations. FM 100-19.(Washington: U.S. Department of the Army, 1 July 1993), 5-4.
32. JTFA-AAR, "Overview Executive Summary." 2.
33. JTFA-AAR, "Overview Executive Summary," Encl 1.
34. JTFA-AAR, "Florida Army & Air National Guard After Action Report Executive Summary." 3.
35. JTFA-AAR, "U.S. Air Forces After Action Report Executive Summary," 3.

36. JTFA-AAR, "Surgeon After Action Report Executive Summary," 1
37. Department of the Army, Peace Operations. FM 100-23. (Washington: U.S. Department of the Army, 30 December 1994), 16.
38. JTFA-AAR, "Overview Executive Summary," 6.
39. JTFA-AAR, "Surgeon After Action Report Executive Summary," 2.
40. JTFA-AAR, "Surgeon After Action Report Executive Summary," JULLS.
41. LTC. Melinda Deffer; Executive Officer, Assistant Commander for Force Integration, AMEDD Center and School; telephone interview by author, 18 March 1996.
42. Linton S. Holsenbeck, "Joint Task Force Andrew: The 44th Medical Brigade Mental Health Staff Officer's After Action Review," Military Medicine 159 (1994): 186-191.
43. Department of Defense, Doctrine for Health Service Support in Joint Operations. Joint Publication 4-02. (Washington: U.S. Department of Defense, 26 April 1995), I-6-7.
44. Ibid., IV-7.
45. LTC Walter D.Goolsby; DOD Veterinary Service Activity; telephone interview by author, 29 March 1996.
46. Ibid.,
47. Deffer.
48. Department of Health and Human Services, Public Health Service (DHHS/PHS), Report of Hurricane Andrew Health and Medical Response Demobilization Debriefing Conference, November 9-11,1992. January 1993. p III-88.
49. LTC. James L. Fletcher, Commander, 32d Medical Battalion (Logistics). Unit Assemblage List, Humanitarian Augmentation (DRAFT), 16 July 1994.
50. DHHS/PHS, III-2.
51. JT Pub 4-02, II-2.
52. AMEDD Center & School, Medical Re-engineering Initiative, Briefing for Commander, Forces Command, Gen.Tilelli, February 1996.
53. Lore E. Lee, et al, "Active Morbidity Surveillance after Hurricane Andrew, Florida, 1992," Journal of the American Medical Association 270 (1993): 591-594.

54. DHHS/PHS, II-9.

55. Department of the Army, Identification, Surveillance, and Administration of Personnel Infected with Human Immunodeficiency Virus (HIV), Army Regulation 600-110 (Washington: U.S. Department of the Army, 22 April 1994), 20.

56. COL. Rodney G. Day; Chief, Program Management Division, Headquarters, U.S. Army Medical Command; telephone interview by author, 29 March 1996.

57. AMEDD Center & School

58. JTFA-AAR, "Surgeon After Action Report Executive Summary," Encl 3.

59. FM 100-13, 16.

60. Lee, 591

61. Joseph F. Waeckerle, "Disaster Planning and Response." New England Journal of Medicine 320, no. 12 (1991): 815.

## BIBLIOGRAPHY

1. AMEDD Center & School. Medical Re-engineering Initiative. Briefing for Commander, Forces Command, Gen. Tilleli, February 1996.
2. Anderson, Judith. "Hurricane Andrew - Coping with Medical Wipeout." MD (November 1992): 23-34.
3. Arwood, Thomas B. "The Quartermaster and Humanitarian Support Missions." Quartermaster Professional Bulletin (Spring 1995): 5-7.
4. Centers for Disease Control. "Preliminary Report: Medical Examiner Reports of Deaths Associated with Hurricane Andrew - Florida, August 1992." Morbidity and Mortality Weekly Report 41, no.35 (1992): 641-644.
5. Clark, Charles S. "Disaster Response - Does the Country Need a New National Strategy?" CO Researcher 3, no.38 (1993): 889-911.
6. Day, Rodney G., Chief, Program Management Division, Headquarters, U.S. Army Medical Command; telephone interview by author, 29 March 1996.
7. Defer, Melinda, Executive Officer, Assistant Commander for Force Integration, AMEDD Center & School; telephone interview by author, 18 March 1996.
8. Fletcher, James L., Commander 32d Medical Battalion (Logistics). Unit Assemblage List, Humanitarian Augmentation (Draft), 16 July 1994.
9. Ginzburg, Harold M; Jevic, Robert J; and Reutershan, Thomas. "The Public Health Service's Response to Hurricane Andrew." Public Health Reports 108, no.2 (1993): 241-244.
10. Goolsby, Walter D., DOD Veterinary Service Activity; telephone interview by author, 29 March, 1996.
11. Harrison, Thomas G. Peacetime Employment of the Military - The Army's Role in Domestic Disaster Assistance. Carlisle Barracks, PA: U.S. Army War College, 1992.
12. Holsenbeck, Linton S. "Joint Task Force Andrew: 44th Medical Brigade Mental Health Staff Officer's After Action Review." Military Medicine 159 (1994): 186-191.
13. Joint Task Force Andrew. Joint Task Force Andrew After Action Report. Miami, Federal Emergency Management Office - 955, 1992.



14. Lee Lore E. et al. "Active Morbidity Surveillance after Hurricane Andrew, Florida, 1992." Journal of the American Medical Association. 270, (1993): 591-594.
15. Natural Hazard Center, "President Raises FEMA Director to Cabinet Level Post." Disaster Research. hazards@lists.colorado.edu (15 March 1996).
16. Robert T. Stafford Disaster Relief and Emergency Assistance Act. U.S. Code, Vol. 42, sec 5121 (1974).
17. Steele, Dennis. "Digging Out From Despair." Army , (Nov 1992): 22-25.
18. U.S. Department of the Army. Domestic Support Operations. FM 100-19. Washington: U.S. Department of the Army, 1 July 1993.
19. U.S. Department of the Army. Peace Operations. FM 100-23. Washington: U.S. Department of the Army, 30 December 1994.
19. U.S. Department of the Army. Identification, Surveillance, and Administration of Personnel Infected with the Human Immunodeficiency Virus (HIV). Army Regulation 600-110. Washington: U.S. Department of the Army, 22 April 1994.
20. U.S. Department of Defense. Doctrine for Health Service Support in Joint Operations. Joint Publication 4-02. Washington: U.S. Department of Defense, 26 April 1995.
21. U.S. Department of Defense. Military Support to Civil Authorities. Department of Defense Directive. Washington: U.S. Department of Defense, 15 January 1993.
22. U.S. Department of Health and Human Services, Public Health Service. Report of Hurricane Andrew Health and Medical Response Demobilization Debriefing Conference, November 9-11, 1992. Washington: U.S. Department of Health and Human Services, January 1993.
23. U.S. Department of Health and Human Services, Public Health Service, Office of Emergency Preparedness / National Disaster Medical System. National Disaster Medical System Strategic Vision. Washington: U.S. Department of Health and Human Services, 1994.
24. U.S. Federal Emergency Management Agency. The Federal Response Plan. Washington: U.S. Federal Emergency Management Agency, 1992.
25. U.S. Federal Emergency Management Agency. "FEMA's Mission." <http://www.fema.gov/fema/mission.html>, accessed 17 March 1996.

26. U.S. General Accounting Office. Disaster Management - Recent Disasters Demonstrate the Need to Improve the Nation's Response Strategy. (GAO/T-RCED-93-4). Washington: U.S. General Accounting Office, 1993.
27. Waeckerle, Joseph F. "Disaster Planning and Response." New England Journal of Medicine. 320, no. 12 (1991): 815-821.