

Presented at the 1998 ASHRAE Winter Meeting, January 17-21, 1998, San Francisco, CA, and published in the proceedings.

The Significance of Bolts in the Thermal Performance of Curtain-Wall Frames for Glazed Facades

Brent Griffith, Elizabeth Finlayson, Mehrangiz Yazdanian, and Dariush Arasteh

August 1997

The Significance of Bolts in the Thermal Performance of Curtain-Wall Frames for Glazed Facades

Brent Griffith, Elizabeth Finlayson, Mehrangiz Yazdanian, and Dariush Arasteh

Abstract

Curtain walls are assemblies of glazings and metal frames that commonly form the exterior glass facades of commercial buildings. Evaluating the thermal performance of the bolts that hold curtain wall glazings in place is necessary to accurately rate the overall thermal performance of curtain walls. Using laboratory tests and computer simulations, we assessed the thermal performance of several different configurations of bolts and glazings. Curtain-wall samples were tested at an infrared thermography laboratory. Experimental results were compared to two-dimensional simulations approximating the thermal effect of the bolts using the "parallel path" and the "isothermal planes" calculation methods. We conclude that stainless steel bolts minimally affect curtain-wall thermal performance (approximately 18%) when spaced at least 230 mm apart, which is the industry standard. Performance is increasingly compromised when there is less than 230 mm between bolts or when steel bolts are used. We also show that the isothermal planes method of approximating curtain wall thermal performance can be used with 2-D heat transfer software typical of that used in the window industry to give conservative results for the thermal bridging effect caused by bolts.

Introduction

Exterior glass facades known as curtain walls are commonly used in commercial buildings. Curtain walls use aluminum framing systems to secure dual-layer insulating glazing units. Screw-thread fasteners or bolts clamp the glazings between the aluminum frames. The bolts can serve as pathways for heat to flow from the warm side to the cold side of the curtain wall.

Efforts are under way to establish procedures for rating the thermal performance of curtain walls. As part of these efforts, this paper reports on experiments and computer simulations studying the effects of bolts on the thermal performance of aluminum curtain walls. Small vertical specimens of a curtain-wall frame with different fasteners and glazing configurations were subjected to steady-state infrared (IR) thermography tests under standard American Society of Heating, Refrigeration, and Air Conditioning Engineers (ASHRAE) design conditions for winter heating. IR thermography testing provides detailed and accurate warm-side surface temperatures (Türler 1997, Griffith 1995). Simulations used a two-dimensional, finite-element program to solve for heat flows. Experimental results were compared to simulation results to try to develop a means of modeling curtain walls with a two-dimensional program. Comparisons between experimental and simulation results are based on surface temperatures because of the difficulty in measuring frame heat flow rates accurately.

Methodology

Test Specimens

Samples of the vertical components of an aluminum curtain-wall frame were obtained from a manufacturer. The frame cross sections are shown below (Figures 1-4) as they were modeled by computer simulation.

Several different combinations of bolts and glazings were studied. Nylon bolts, 6.4 mm in size and spaced at the industry standard distance of 229 mm apart, were tested to establish a baseline case that would be as close as possible to using no bolts at all. Although nylon is far too flimsy for use in actual applications, its low conductivity allowed us to approximate a "no-bolt" configuration while still holding the curtain-wall assembly together during the IR thermography experiments.

Tests were also performed using the industry's standard fasteners: 6.4 mm, self-tapping stainless steel bolts. These were tested at several distances ranging from 76 to 457 mm apart to determine the effect of bolt spacing on thermal performance. The cold side of the curtain-wall frame had predrilled holes approximately 76 mm apart for the bolts. The bolts self-drill through a rubber gasket and then bite into an aluminum channel in the central rib of the warm-side curtain-wall frame, screwing in until they cannot penetrate further.

Highly conductive 7.9 mm steel bolts were also tested with 229 mm spacing between them. The curtain-wall frame's aluminum channel was tapped with threads to accept both the steel and nylon bolts.

Test specimens were constructed with "pseudo" custom built glazings (IGs) rather than real ones to eliminate the variation in edge performance associated with convection inside the gap of a real glazing. These pseudo glazings substitute foam for air in an insulating glass unit. This configuration approximates the thermal bridging of an aluminum spacer without the complicating performance of a glazing cavity. Figures 1 and 2 show the edge configurations of these pseudo IGs. Figure 3 shows the pseudo IG in the no-bolt configuration.

Simple sheets of extruded polystyrene foam board were also tested in place of glazing; the polystyrene sheets eliminate the glazing spacer in order to separate the thermal bridging effect from the bridging effect of the bolts. Two orientations of "foam glazings" were used to determine the effect of the air cavity that exists parallel to the central rib of the curtain wall's frame system (Figure 4). In one orientation, the foam glazing is in a standard position with an air gap between glazing and bolt, and, in the other orientation, the foam glazing is butted directly against the bolt with no air gap.

Table 1 shows the various curtain-wall specimen configurations that were measured and/or simulated.

TABLE 1. Test Specimen Descriptions

Fastener Type Material-Nominal Size	Bolt Spacing (nominal mm)	Glazing	Glazing Position
Nylon-6.4 mm	229	Pseudo IG	Standard
Stainless-6.4 mm	457	Pseudo IG	Standard
Stainless-6.4 mm	305	Pseudo IG	Standard
Stainless-6.4 mm	229	Pseudo IG	Standard
Stainless-6.4 mm	152	Pseudo IG	Standard
Stainless-6.4 mm	76	Pseudo IG	Standard
Steel-7.9 mm	229	Pseudo IG	Standard
Stainless-6.4 mm	229	Foam	Standard
Stainless-6.4 mm	229	Foam	Butted

Experiments

A special assembly was constructed so the curtain-wall samples could be tested at the author's Infrared Thermography Laboratory (IRLab). Figure 5 shows how the test specimens were mounted. The frame components tested were about one meter long. The mounting created adiabatic edges at the ends of these lengths.

Two environmental chambers created heat flow through the specimen as in hot-box testing for winter heating conditions. The warm chamber was a thermography chamber designed for an unobstructed view of the specimens, so it did not employ a typical hot-box baffle. The chambers and related instrumentation are described in Türler 1997.

A cold-side chamber moved air in a plenum up the back of the specimen; velocity was about 3.2 m/s at middle of the specimen's main face during the measurements. On the warm side, air was slowly circulated through a subfloor where temperature conditioning occurred. An air sink below the specimen removed cooled air. The air sink opening was 47 mm wide, and the air velocity was typically 0.6 m/s.

Specimen surface temperatures were measured along the surface halfway up the specimen face. The surface temperature was determined by averaging the temperature over a 44 mm square using a 20 x 20 point grid. The averaging technique is detailed in the literature (Türler 1997). Temperature measurements on the interior surface of the curtain-wall assembly did not vary as a function of distance from the bolt. In other words, the aluminum was thick enough to spread the bolt's thermal bridging effect over the entire surface. Detailed discussion of the IR thermography and external referencing technique developed for this purpose are presented elsewhere (Griffith 1995, Griffith 1996, and Türler 1997). An infrared thermal imager provided noninvasive temperature measurements of frame sections. An external reference emitter technique was used to improve accuracy of the measurements. Thermocouples (type T, special limits, 30GA) were also mounted on the specimen's cold side.

Environmental conditions are summarized concisely as air temperatures and mean surface heat-transfer coefficients or film coefficients. Air temperatures were held to within +/- 0.1 °C of the

-17.8°C and 21.1°C set points on the cold and warm sides, respectively. Chamber settings could be varied to provide some control over air flow and film coefficients. Settings were selected based on the results of separate experiments that used a calibrated transfer standard (CTS) specimen to measure film coefficients directly.¹ The curtain wall and the CTS have different thermal performances, so they also have different film coefficients. Because overall heat flow through the curtain-wall frame was not metered, no reasonable method of estimating the "as tested" film coefficients is available at the time of this writing. The estimated absolute accuracy of the temperature values is +/- 0.5°C; the estimated relative accuracy between measurements is +/-0.1°C.

Computer Modeling

Simulation results for the curtain wall samples were generated using an in-house beta version of the computer program THERM 2.0. THERM (Finlayson 1996) is a two-dimensional effective conductivity heat transfer analysis program. It is typical of 2-D heat transfer programs used in North America, Europe, New Zealand, and Australia to quantify the thermal performance of fenestration products for comparative purposes. THERM uses a finite-element method to solve two-dimensional conduction and radiation heat-transfer problems for arbitrarily shaped geometries. Although THERM 2.0 can model air flow in frame cavities using local film coefficients and includes a radiation view factor algorithm, the industry standard methods for modeling convection and radiation at the boundary and within frame cavities (NFRC 1997) were used in this analysis.

Table 2 lists the materials properties and Table 3 lists the boundary conditions used to create the heat-transfer model of the two-dimensional curtain wall cross section. The thermal bridging effect caused by the bolts is three-dimensional. THERM cannot model this effect directly, so approximate methods developed to model discontinuous highly conductive members in wall constructions are also used. For this problem, there are two applicable engineering methods for approximating the bolt's three-dimensional effects: the "parallel path" method and the "isothermal planes" method. The experimental results are expected to fall between these two results (ASHRAE, 1993). Although 3-D models exist that are capable of modeling the bolt effect directly, it is desirable to determine how well standard industry 2-D procedures model this problem. These 2-D effective conductivity procedures cannot capture in detail all of the complexities of the analysis, such as air motion in the cavities and contact resistance on a microscopic level; however such procedures may be adequate for product evaluation.

¹ The CTS film coefficients were adjusted to be within five percent of the desired 7.9 W/m²K on the warm side and 10% of 29 W/m²K on the cold side. The CTS used here was constructed from 25.4 mm thick expanded polystyrene foam board sandwiched between 4.7mm glass sheets. The 900 mm square CTS had a total thickness of 35 mm and was mounted flush on the warm side in a 39.4 mm thick surround panel made of XEPS. Eighteen pairs of thermocouples located at each internal surface provided heat flow and temperature data so the total film coefficients, which are mean values for the entire specimen, could be determined. Bulk air temperature values are averages for the warm and cold sides, respectively, and were derived from direct contact measurements using 100 ohm platinum resistance thermometers.

TABLE 2. Material Properties Used in Computer Simulations

Material	k Thermal Conductivity W/mK
Foam (XEPS)	0.028
Aluminum	160
Glass	1.0
Silicone Sealant	0.36
Neoprene Gasket	0.19
“No-bolt” model	0.21
Stainless Steel	14.3
Steel	48

TABLE 3. Boundary Conditions Used in Computer Simulations

	Temperature (C)	Total Surface Film Coefficient (W/m²K)
Warm Side	21.1	8.3
Cold side	-17.8	29.0

To use both the parallel and the isothermal planes methods it is necessary to understand how to most accurately represent the bolt in the thermal model. Figure 6 shows a base model of a bolt from which several issues were studied. These included (1) the characteristic dimension of a 6.4 mm bolt with a 12.7 mm head, (2) the importance of modeling the 0.2 mm air gap between the bolt and the predrilled bolt hole, and (3) the importance of modeling the screw threads. The results of these sensitivity studies show that the 12.7 mm bolt, compared to a fictitious 6.4 mm bolt head, creates a fin effect and thus the characteristic dimension should be assumed to be 12.7 mm. Secondly, the 0.2 mm air gap must be included since it acts as a thermal break. Finally, the threads of the bolt do not need to be modeled exactly, since modeling the bolt as being in continuous contact with the aluminum only results in a 0.5% increase in heat flow.

The parallel method requires two THERM runs, one for the no-bolt geometry, shown for the pseudo-IG configuration in Figure 3, and one for the bolt geometry, shown for the same configuration in Figure 2. To determine the correct model for the no-bolt geometry, we first considered the thermal effect of the predrilled holes on three-inch centers. These holes result in a change in U-value of a maximum of four percent for the butted foam configuration and a minimum of one percent for the pseudo-IG case. Thus, the effect of the predrilled holes in the no-bolt case was determined to be negligible. U-values were obtained for the bolt (U_b) and no-bolt (U_n) geometries for each of the glazing configurations, using the material properties and

boundary conditions from Table 2 and Table 3. These U-values were then area weighted using percentages based on the 12.7 mm bolt effective dimension and the nominal bolt spacing to determine the U-value based on the parallel method (U_p):

$$U_p = F_b \cdot U_b + F_n \cdot U_n$$

Where,

F_b = fraction bolt = 12.7/Nominal bolt spacing in mm,

F_n = fraction no-bolt = 1- F_b .

The isothermal planes method requires only one THERM run. Before this run can be made however, the effective conductivity of the materials comprising the “bolt-space” in the no-bolt case must be determined. The actual materials that make up the “bolt space” in the no-bolt case are two air spaces, a section of aluminum, and a section of neoprene rubber. This effective conductivity was calculated as the inverse of the sum of the resistances, divided by the total length of the bolt. When this effective conductivity (0.211 W/m-K) was used in a “bolt” model for the conductivity of the entire bolt, the U-value results matched the results of the no-bolt case.

The isothermal planes method uses an area-weighted average of the bolt conductivity (k_b) and the no-bolt conductivity (k_n) to determine an effective conductivity (K_{eff}):

$$K_{eff} = F_b \cdot k_b + F_n \cdot k_n.$$

The value for the effective conductivity is then used with the bolt geometry to obtain U-values and average temperatures.

Discussion

Table 4 shows the average temperatures and U-values found using the parallel path and isothermal plane methods. The average temperatures for the parallel method were obtained from effective bolt conductivity values which matched the parallel method’s area weighted U-values to two decimal places. For most cases, the parallel method over-predicts the experimentally determined average temperature results and thus can be considered to under-predict the effect of the bolt on frame U-factors. Average temperatures and U-values are obtained directly with the isothermal planes method. These results consistently under-predict the experimentally determined average temperature and can be considered to over-predict the frame U-value.

TABLE 4. Average Temperature and U-Values From Experiments and Parallel Path and Isothermal Planes Calculation Methods

Specimen	Bolt Spacing (mm)	Warm Side Average Temperature (°C)			Frame U-Factor (W/m ² K)	
		Experimental (+/- 0.5 °C)	Parallel Method	Isothermal Planes Method	Parallel Method	Isothermal Planes Method
PSEUDO IG UNIT						
No Bolt			11.5	11.5	2.17	2.17
Nylon Bolt	229	12.4	11.5	11.5	2.17	2.17
Stainless	457	11.0	11.3	10.5	2.21	2.39
Stainless	305	10.8	11.2	10.1	2.24	2.48
Stainless	229	10.7	11.1	9.8	2.26	2.55
Stainless	152	10.5	10.9	9.2	2.30	2.68
Stainless	76	9.4	10.3	7.9	2.43	2.95
Steel	229	8.8	11.1	7.7	2.27	3.00
FOAM GLAZING						
Stainless	229	13.9	13.5	11.6	1.65	2.11
FOAM BUTT						
Stainless	229	14.9	14.1	12.0	1.56	2.03

Although no systematic attempt was made to define the simulation uncertainty, note that a 5-10% uncertainty in the final frame U-value would correlate to a 0.5–1.0°C uncertainty in the warm-side surface temperature (for the sample that has a 10°C ΔT between the warm-side surface temperature and the air temperature). This in addition to the experimental uncertainty results in an expectation of agreement between simulation and experiment within 1.0-1.5°C. For the pseudo IG units, there is good agreement between experiment and simulation, with the isothermal plane method yielding consistently conservative results. For the two cases without the metal spacer the parallel path method yields better agreement. It is recommended (ASHRAE, 1993) that the isothermal plane results be used if there is a layer of high lateral conductivity and

the parallel path results should be used if there is no such layer. Replacing the spacer in the pseudo-IG with pure foam removes an important highly conductive layer and perhaps explains why the parallel path method gives better results in these cases. In all cases the isothermal planes method yields conservative results and those results will be considered in this discussion.

Table 4 shows that stainless steel bolts spaced 230 mm (the industry standard) or more apart cause a small increase (18%) in heat loss of a curtain wall. Differences in heat loss for 229, 305, and 457 mm on-center spacing are minimal. However, once the distance between bolts is less than 230 mm, heat loss increases substantially as the distance between the bolts decreases.

The 6.4 mm stainless steel bolts showed less heat loss during experiments than the larger steel bolt that was tested. For the same spacing between bolts, the large steel bolts resulted in an increase of frame heat loss of frame U-value that was 18% higher than the value found with the standard stainless steel bolts. The parallel method is not able to capture this trend even though the conductivity of the steel bolt is more than three times that of the stainless steel bolt.

Conclusions

This study of heat flow through curtain-wall frames shows that:

1. Thermal bridging through bolts affects the thermal performance of curtain-wall frames, but the effect is not extremely detrimental for standard materials and spacing (for stainless steel bolts spaced 229 mm apart, frame U-values increase by about 18%).
2. The intermittent contact between bolt threads and frame housing does not seem to affect thermal performance. There is sufficient area of unrestricted heat flow that the bolt shaft can be modeled as if it is in continuous contact with the frame. The bolt head in contact with the aluminum extrusion acts as a fin, however, and thus must be considered in the analysis. The size of the bolt head rather than the bolt shaft governs the bolt's effect. The air gap between the predrilled bolt hole and the bolt significantly reduces the bolt's thermal effect. Although the isothermal planes method only requires one THERM run, the determination of the correct effective conductivities may require additional calculations.
3. Stainless steel bolts offer better thermal performance in curtain walls than do steel bolts. The parallel method of calculating thermal performance cannot capture this difference, but the series method can.
4. The isothermal planes method of approximating three-dimensional effects with 2-D heat transfer tools typical of those in use by the window industry gives conservative results for the effects of curtain-wall bolts and can be used if true three-dimensional simulation methods are not available or cost-effective.

Acknowledgments

The authors greatly appreciate the assistance of Nan Wishner in writing this paper and of Paul LaBerge and Chad Goudy for technical help with this effort. The authors gratefully acknowledge the materials provided by Kawneer for this study. This work was supported by the Assistant Secretary for Energy Efficiency and Renewable Energy, Office of Building Technology, State and Community Programs, Office of Building Systems of the U.S. Department of Energy under Contract No. DE-AC03-76SF00098.

References

ASHRAE. 1993. 1993 ASHRAE Handbook of Fundamentals, Atlanta: American Society of Heating, Refrigerating, and Air-Conditioning Engineers, Inc.

Finlayson, E. U.; D. Arasteh; C. Huizenga; D. Curcija; M. Beall; and R. Mitchell. 1996. THERM 1.0: Program description. LBL Report 37371, Lawrence Berkeley National Laboratory, Berkeley, CA.

Griffith, B.T.; D. Türlér; and D. Arasteh. 1996. Surface temperatures of insulated glazing units: infrared thermography laboratory measurements. ASHRAE Transactions Vol. 102 Part 2.

Griffith, B.T.; F. Beck; D. Arasteh; and D. Türlér. 1995. Issues associated with the use of infrared thermography for experimental testing of insulated systems. Proceedings of the Thermal Performance of the Exterior Envelopes of Buildings VI Conference, Atlanta, GA: American Society of Heating, Refrigerating and Air-Conditioning Engineers.

National Fenestration Rating Council. 1997. Simulation Manual. Silver Spring, MD.

Türlér, D.; B. Griffith; and D. Arasteh. 1997. Laboratory procedures for using infrared thermography to validate heat transfer models. Insulation Materials: Testing and Applications, Third Volume ASTM STP 1320. R. S. Graves and R. R. Zarr, Eds., Philadelphia, PA: American Society for Testing and Materials.

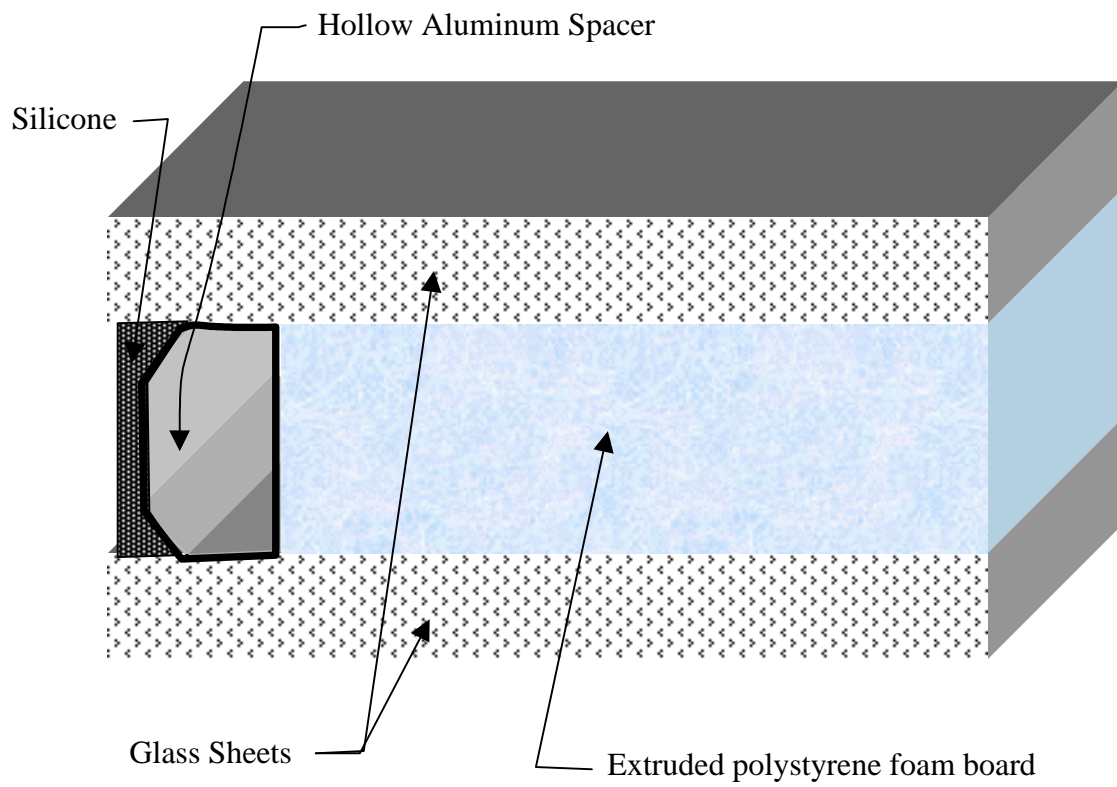

Figure 1. Pseudo Insulated Glazing

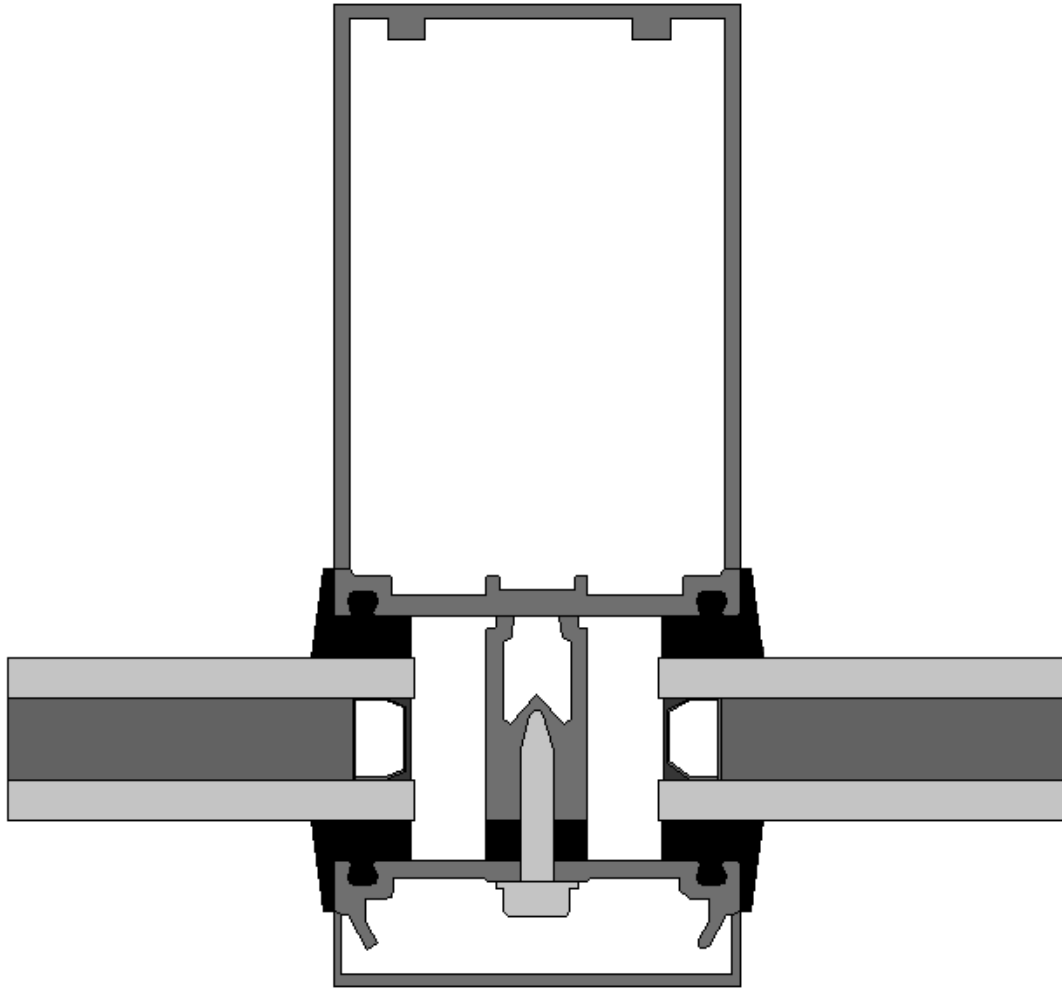

Figure 2. Frame cross section with fastener, shown with Pseudo IG.

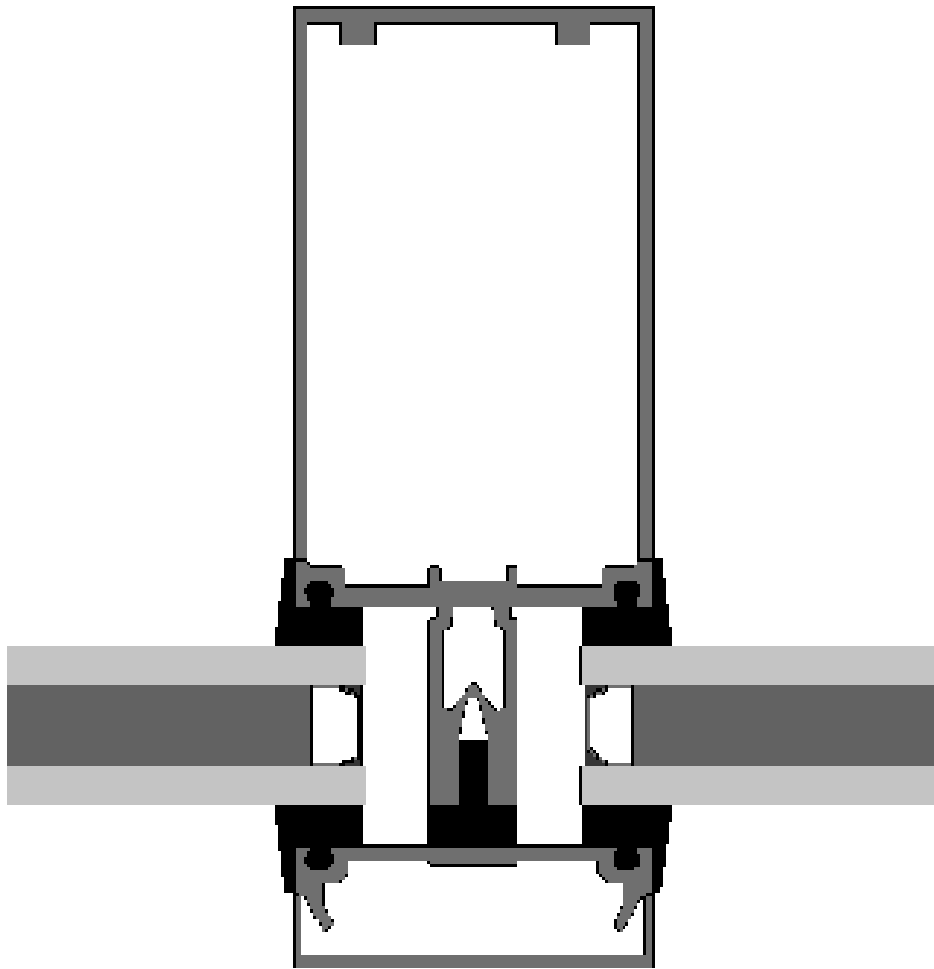

Figure 3. Frame cross section without fastener, shown with Pseudo IG.

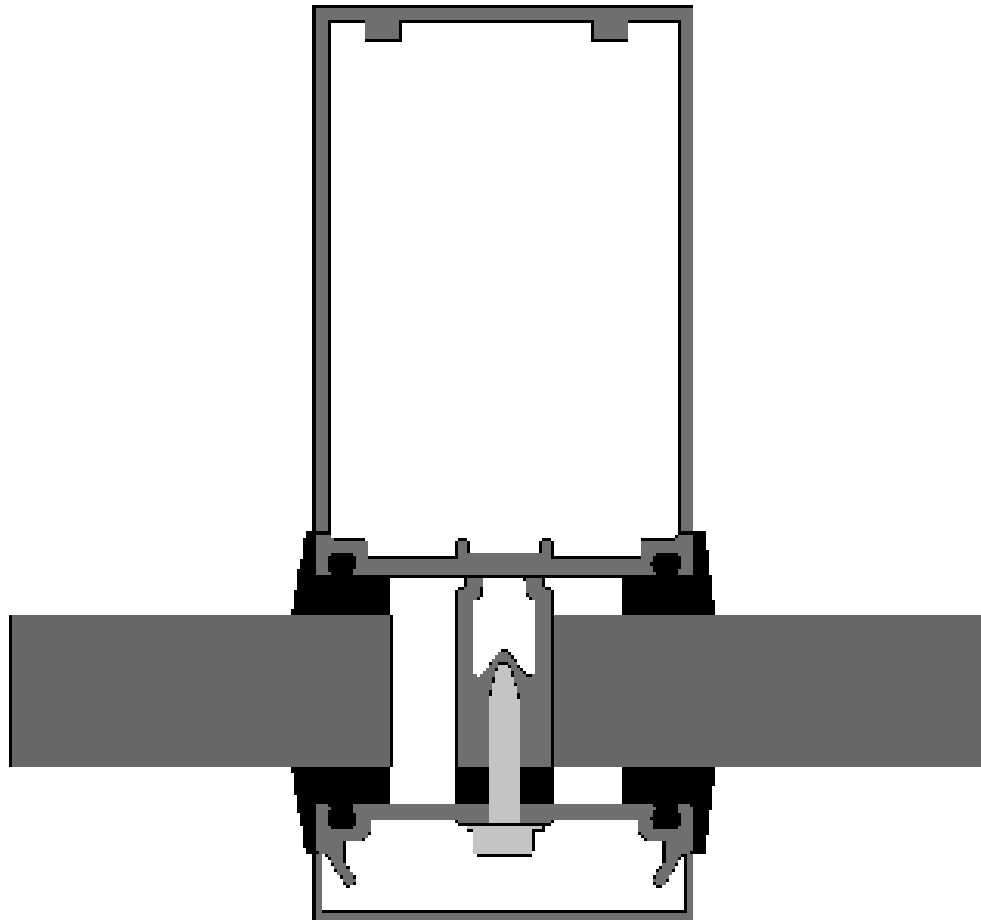

Figure 4. Frame cross section with fastener showing with foam glazing in standard position and in butted position.

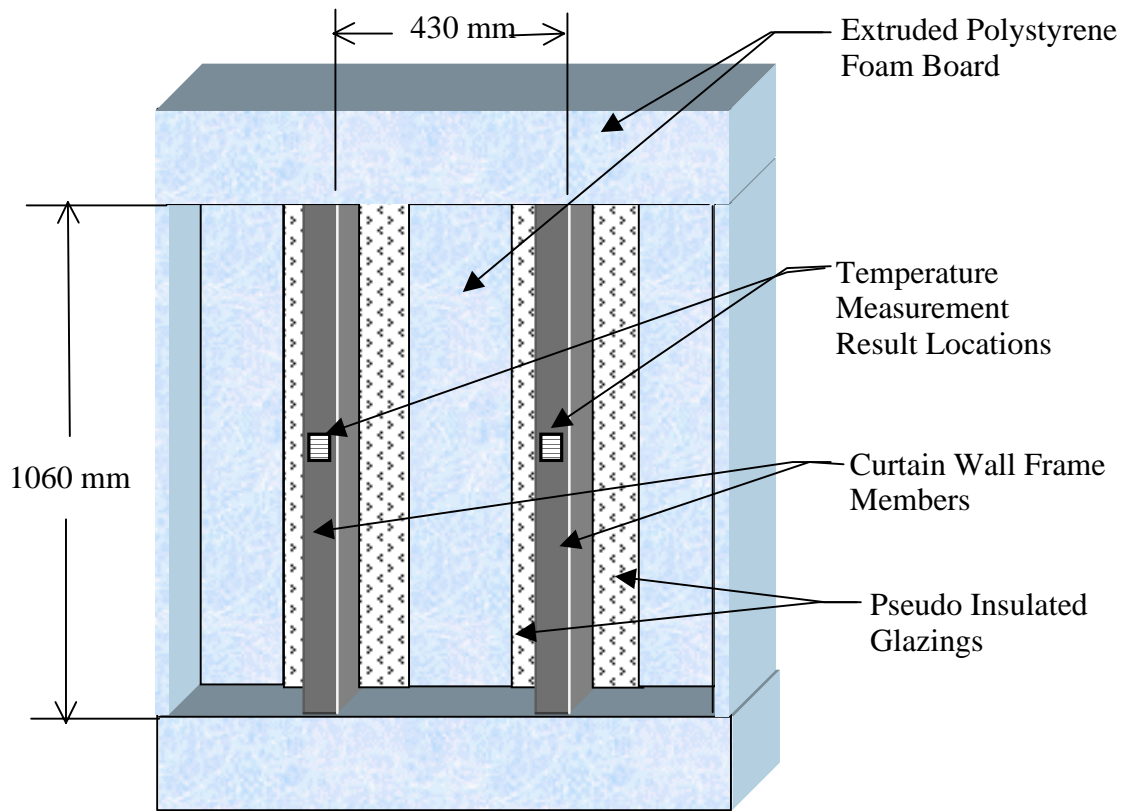
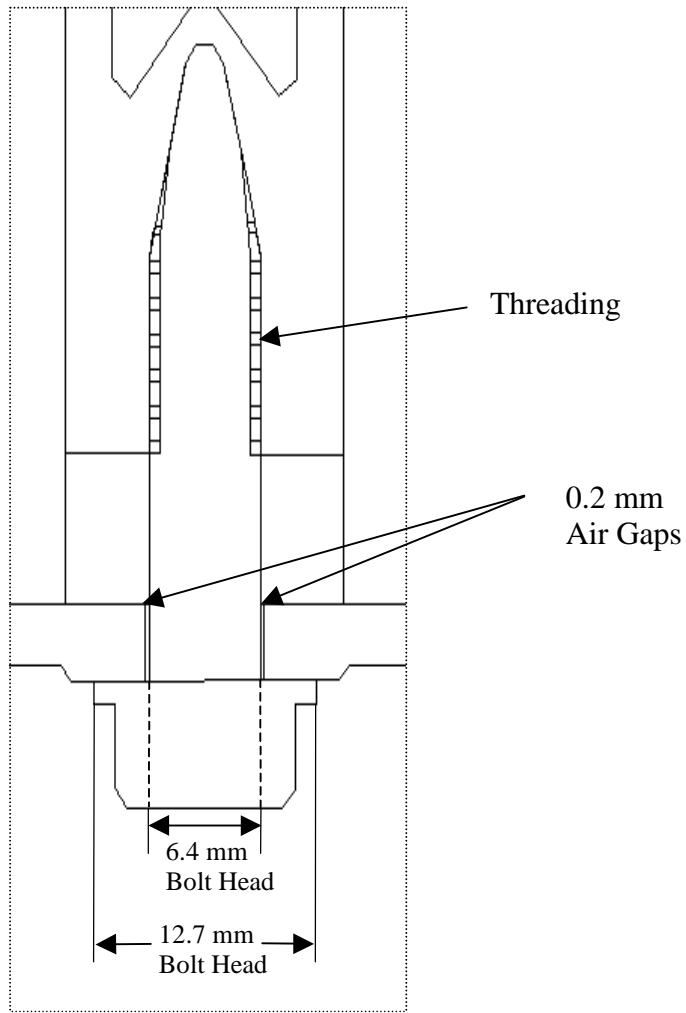

Figure 5. Warm side view of specimen mounting configuration for thermal tests.



Case		Frame U-Value (W/m ² K)
Air Space Between Bolt and Aluminum (mm)	Bolt Head Dimension (mm)	
None	12.7	3.81
0.2	12.7	3.69
None	6.4	3.77
0.2	6.4	3.05
0.2	12.7	3.67

Figure 6. Details of bolt model used for determining the effective dimension for the bolt.