

The Speaker's Linearization Problem [and Discussion]

W. J. M. Levelt, R. B. Le Page and H. C. Longuet-Higgins

Phil. Trans. R. Soc. Lond. B 1981 **295**, 305-315

doi: 10.1098/rstb.1981.0142

Rapid response

[Respond to this article](#)

<http://rstb.royalsocietypublishing.org/letters/submit/royptb;295/1077/305>

Email alerting service

Receive free email alerts when new articles cite this article - sign up in the box at the top right-hand corner of the article or click [here](#)

To subscribe to *Phil. Trans. R. Soc. Lond. B* go to: <http://rstb.royalsocietypublishing.org/subscriptions>

The speaker's linearization problem

BY W. J. M. LEVELT

Max-Planck-Institut für Psycholinguistik, Berg en Dalseweg 79, NL-6522 BC, Nijmegen, The Netherlands

The process of speaking is traditionally regarded as a mapping of thoughts (intentions, feelings, etc.) onto language. One requirement that this mapping has to meet is that the units of information to be expressed be strictly ordered. The channel of speech largely prohibits the simultaneous expression of multiple propositions: the speaker has a linearization problem – that is, a linear order has to be determined over any knowledge structure to be formulated. This may be relatively simple if the informational structure has itself an intrinsic linear arrangement, as often occurs with event structures, but it requires special procedures if the structure is more complex, as is often the case in two- or three-dimensional spatial patterns. How, for instance, does a speaker proceed in describing his home, or the layout of his town?

Two powerful constraints on linearization derive, on the one hand, from 'mutual knowledge' and, on the other, from working memory limitations. Mutual knowledge may play a role in that the listener can be expected to derive different implicatures from different orderings (compare 'she married and became pregnant' with 'she became pregnant and married'). Mutual knowledge determinants of linearization are essentially pragmatic and cultural, and dependent on the content of discourse. Working memory limitations affect linearization in that a speaker's linearization strategy will minimize memory load during the process of formulating. A multidimensional structure is broken up in such a way that the number of 'return addresses' to be kept in memory will be minimized. This is attained by maximizing the connectivity of the discourse, and by backtracking to stored addresses in a first-in-last-out fashion. These memory determinants of linearization are presumably biological, and independent of the domain of discourse.

An important question is whether the linearization requirement is enforced by the oral modality of speech or whether it is a deeper modality-independent property of language use.

INTRODUCTION

Whenever a speaker wants to express anything more than the most simple assertions, requests, commands, etc., he or she has to solve what I shall call the *linearization problem*: the speaker will have to decide on what to say first, what to say next, and so on. Though the linearization problem has been the subject of pedagogical and philosophical treatises from pre-Aristotelian times until the nineteenth century, the issue is curiously absent from present-day psycholinguistic literature.

The sixteenth-century humanist philosopher Pierre de la Ramée explains the linearization problem by giving the example of a teacher who plans to give a course in grammar (Ramus 1546, p. 83):

Let us suppose that all the rules, definitions, and divisions of grammar have been ascertained, that all the examples used in grammar have been found, and that all these things have been

[91]

truly and correctly 'judged'. Let us suppose that all these prescriptions are written out, each on a separate little ticket, and all of these thoroughly mixed in an urn, as for a game of *blanque*. Now I ask what part of dialectic would teach me how to put together all these mixed-up precepts and to reduce them to order.

Ramus makes a careful distinction between this ordering and two other aspects of the generation of discourse. The first one is the retrieval and judgement of the things to be expressed. Ramus puts it this way:

There is no need here of dialectical invention to discover the precepts, for all have been found and all the parts tested and judged. There is no need here of syllogism, because what is true here is already understood.

In other words, for Ramus arrangement follows, or at least presupposes, retrieval and judgement. The other aspects to be distinguished from ordering is the choice of linguistic means to express such an ordered string of thoughts. Here, Ramus breaks with the traditional treatment of linearization. From the classical era onwards, arrangement is discussed in rhetoric texts in the chapter on *dispositio*.[†] But rhetoric has to do with *oratio*, the faculty of speech, whereas Ramus repeatedly stresses that arrangement and judgement are independent of the faculty of speech, and are solely a matter of the faculty of thought, or *ratio* (see Nuchelmans 1980, p. 17). The linearization problem, therefore, should not be treated as a problem of language, but as a problem of thought, and Ramus consequently handles it, just as he does syllogism, as part of dialectic rather than of rhetoric.

As far as this goes, I am a Ramist: in studying the speaker's generation of discourse one should carefully distinguish between the selection of information to be expressed, the ordering of this information for expression, and the linguistic formulation of the information. A discussion of the speaker's linearization problem should, more specifically, avoid stating the issue in terms of the ordering of clauses, sentences, utterances, or other linguistic units. The entities should be units in a language of thought, which are, admittedly, even harder to define than units of a natural language (see Fodor 1975). In the eventual terminology used by Ramus, these units were *arguments* – roughly equivalent to concepts – and *axioms*, which are arguments combined into statements.

Making this strict separation between thought and language does not, of course, entail a denial of their interaction. The grammar of a language may put certain boundary conditions on the order in which thoughts can be expressed, and the order of expression decided on will in turn limit the choice of appropriate grammatical forms. None the less, the two systems may differ substantially in their main principles of organization.

What are the principles underlying the speaker's linearization in discourse? As I remarked above, there is virtually nothing in the psycholinguistic literature relating to this issue, in spite of the fact that it should figure centrally in any theory of the speaker. In the following I shall sketch some main principles of linearization as I see them. They are partly speculative, but in large part also based on empirical research. I shall begin with the speculative part, which concerns principles that are related to the content of discourse. I shall then turn to the more empirically based part, which deals with principles that derive from process requirements in

[†] See for instance, the Latin text on rhetoric, which is traditionally, but erroneously, attributed to Marcus Tullius (Cicero) (*ca.* 85 B.C.). Kempen & van Wijk (1981) were the first to relate this text to the linearization problem.

the generation of discourse. A final section will comment on the relation between linearization and the oral modality of speech.

CONTENT-RELATED PRINCIPLES

The art of rhetoric has been developed to effectively influence or persuade the audience. Every main aspect of this art, be it invention, elocution or pronunciation, is dedicated to this goal. Linearization, too, serves the main purpose of evoking certain inferences in the mind of the listener. Order is one determinant of implicature, as Lyons (1977), Gazdar (1979, 1980) and others have shown. An example from Kempson (1975) suffices to illustrate this. If the context is not too far-fetched, the following piece of discourse sounds distinctly odd:

(1) The Lone Ranger rode off into the sunset. He mounted his horse.

Order of mention apparently implicates order of events, and the way to put things should therefore be the other way round:

(2) The Lone Ranger mounted his horse. He rode off into the sunset.

The old principle in rhetoric corresponding to this is known as *ordo naturalis*.† Natural order is, so to speak, the unmarked form of linearization. All other orders, the so-called artificial orders, are designed to create special attentional or aesthetic effects. A psycholinguistic consideration of linearization can most profitably start out with the unmarked case.

Three questions have to be asked. The first is: what makes natural order so effective for speaker and listener? The second one is how to define natural order for different domains of discourse. And the third issue is: what will happen if a domain does not allow for a unique natural order? Let us consider these issues in turn.

The principle of natural order may have two related, but still different, psychological sources. Both are extensively discussed in Osgood's recent book (1980), which includes a very interesting chapter on naturalness. A first source is the organization of the speaker's own – prelinguistic – experience. An event structure, for instance, is in our culture quite likely memorized in such a way that consecutive events are more closely associated than non-consecutive events. Retrieving this information for expression will be relatively easy if each just-retrieved event can function as a retrieval cue for the next event. Experimental evidence for this conjecture can be found in Mandler & Johnson (1977). I shall return to this use of connectivity in the next section on process-related principles. The other source of natural order is conversational. If the speaker intends the listener to derive certain implicatures from the order in which things are said, he should base his speech on mutual knowledge. There is general knowledge in our culture that causes precede effects, that means are sought before ends are achieved, that planning precedes execution, etc. By using the unmarked order the speaker can make sure that the listener will correctly apply such knowledge, and come up with the intended implicature. There are, moreover, stereotypical orders of events in our culture, such as paying after eating in restaurants (see Schank & Abelson 1977), stereotypical spatial arrangements (see Linde & Labov (1975) on apartment arrangements and their descriptions, and Ullmer-Ehrich (1979) and Ullmer-Ehrich & Koster (1980) on living room arrangements and descriptions), and other stereotypical arrangements that a speaker can assume to be knowledge shared with the listener. By following such arrangements in the order of expression, the speaker facilitates the listener's comprehension.

† Though they are often confused, natural order theories of *dispositio* should be distinguished from natural order theories of grammar. The latter concern word order in sentences. For a discussion of these, see Levelt (1967).

Here the speaker's and the listener's interests are likely to coincide: if the speaker's retrieval process is, in part, governed by what is stereotypic in the culture, the listener will be able to use the same stereotype to encode and store the information. The short answer, therefore, to the question of what makes natural order so natural is that it allows for easy retrieval on the part of the speaker and for easy inference on the part of the listener, given shared general or more specific knowledge in the speech community. At the same time, the culture dependency of natural order cannot be stressed enough. Becker (1980), for instance, shows that the Aristotelian temporal-causal sequencing is no basis for linearization in Javanese Wayang, but rather something he calls 'coincidence', which is a deep motive for action in the culture.

The second question, of how natural order relates to different domains of discourse, will never be answered exhaustively: there are as many natural orders as there are things to talk about, and one should be careful to avoid the morasses of content analysis. One more general observation can, however, be made: if the structure to be expressed is itself linearly arranged, the unmarked or natural way is to follow that order. For event structures the rule is to follow the order of events, as we have seen. For linear spatial structures it is to follow the spatial connectivity. This is especially apparent in the giving of route directions, which has been studied by Klein (1979, 1981) and others in our institute (see also Munro 1977; Wunderlich & Reinelt 1981). The task of giving someone a route direction requires, first, the retrieval of the shortest route through some more-dimensional representation and, secondly, the expression of this shortest route. The latter is always performed by following the route's linear connectivity, though this is by no means the only logical possibility. Sometimes structures are partly organized in terms of subordination, and the linearization follows the route from superordinated to subordinated items. This is, for instance, so with a computer program designed by Collins *et al.* (1975) that teaches geography. The authors claim that this superordination to subordination arrangement of topics implemented in the program had been observed in natural tutorial sessions. It sounds like a late echo of the genus-species orderings propagated in rhetoric texts across the ages.

The third question is what will happen if the domain of discourse has no linear arrangement, and thus cannot directly map onto a unique order of expression. This may occasionally be so for event structures, as when events have a simultaneous arrangement. It is the normal case for two- or more-dimensional spatial structures, and for many other domains of discourse. The only empirical evidence about what happens in such cases concerns the description of multidimensional spatial structures. Since the appearance of Linde & Labov's (1975) seminal paper on apartment descriptions, much attention has been devoted, especially at our institute, to how people express and formulate spatial information (Klein 1979, 1981; Ullmer-Ehrich & Koster 1980; Levelt 1979, 1981). One major result of these studies is this: the dominant strategy for linearizing a spatial structure is by projecting an event structure onto it. Speakers tend to make a mental tour through space, either a body tour (e.g. in apartment descriptions or route directions), or what we have called a gaze tour (in living room or network descriptions). As a result, spatial links become expressed by temporal connectives ('and then'), with abundant use of verbs of motion and the like. The natural order rule for event structures is thus extended to spatial structures, which become only 'indirectly' described via the event structures defined over them. It is not fully clear why speakers resort to these tour solutions. One advantage of the strategy is surely that speaker and hearer share substantial knowledge about the touring of cities and apartments, and a temporal description easily invites the intended inferences about

the spatial layout. Still, though the temporal solution is guaranteed to be linear, it is by no means unique. Mutual knowledge will be one determinant of the tour's path; processing requirements will be another. Let us now turn to these process-related principles of linearization.

PROCESS-RELATED PRINCIPLES

The orderly expression of complex information requires a system of book-keeping on the part of the speaker. It is, first, necessary to keep track of what has been said and what is still to be expressed. This may be a simple matter for linear structures, but it requires special memory

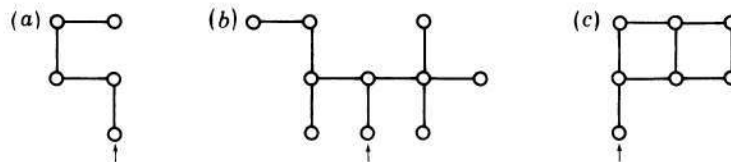

FIGURE 1. Examples of linear (*a*), hierarchical (*b*) and loop (*c*) structures to be described by subjects. Nodes are differently coloured in the test patterns.

devices for more complex information, as I shall show in a moment. Secondly, a cooperative speaker will bear in mind the needs of the listener, who has to try to reconstruct the complex structure from the linearly ordered discourse. The complexity of the demands made on the listener will, among other things, be affected by the speaker's use of modal, anaphoric and deictic expressions, which signal how the formulated information is to be resynthesized. It will also be affected by the speaker's choice of particular orders of expression.

In the following I shall argue that these book-keeping requirements impose restrictions on the linearization process that are of a quite general nature: they are independent of the information content, and are in that respect quite different from content-related principles of linearization discussed earlier.

I shall, however, try to explain these process-related principles of linearization with the help of the very restricted domain of discourse that we have used to study them. The discourse is about spatial, grid-like networks, as in figure 1, consisting of differently coloured nodes, connected by horizontal or vertical arcs. The patterns could have a linear structure, as in figure 1*a*, a hierarchical structure involving multiply branching nodes, as in figure 1*b*, or an even more complex loop-structure as in figure 1*c*. We showed such patterns to subjects and asked them to describe the figure in such a way as to enable the next subject to correctly draw it on the basis of the tape-recorded description. We instructed the speakers to start the description at the node marked by the arrow.

How would a speaker organize his book-keeping when describing such patterns? Notice that book-keeping is necessary here in spite of the fact that the patterns are visually present during the task: the speaker should remember which parts of the pattern he has already described, and in some cases which nodes he will have to return to at later stages of the description. I constructed two linearization models that for each pattern in the domain would yield as output a linear sequence over all nodes and arcs of the pattern. The models would thus predict the subject's order of expressions of the different parts of the pattern.

It suffices for the present discussion to examine one of these models only. The model consists

of two parts, one non-deterministic and one probabilistic. The non-deterministic part is a so-called augmented transition network (a.t.n.). It is given in figure 2. The precise working of this a.t.n. has been described elsewhere (Levelt 1981*b*). What mainly concerns us here is the general principles on which its construction is based, since these are the process-restrictions that we claim to be general and content-independent.

A first major principle is the *maximization of connectivity*. For the present patterns the principle implies that, whenever possible, the next node to be described has an arc-connection to the last node mentioned. Or, in other words, the connectivity principle says that a complex information

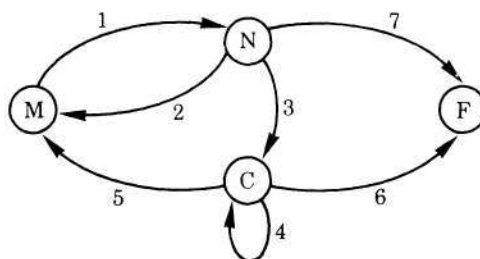

FIGURE 2. Linearization model for network descriptions.

| <i>transition</i> | <i>condition</i> | <i>action</i> |
|-------------------|------------------------------------|---|
| 1 | network entrance | make entry statement; reduce valency of entrance node by 1 |
| | other than network entrance | enter loop if recognized at transition (2); select and describe move, reduce val. of node left and of node entered by 1 |
| 2 | node val. = 1 | describe node |
| | node is loop entrance and val. > 1 | describe node |
| 3 | node val. > 1 | describe node |
| 4 | node val. > 1 | seek M/F |
| 5 | node val. = 1 | — |
| 6 | node val. = 0 | stop |
| 7 | node val. = 0 | describe node, stop |

structure is linearized as much as possible without ‘lifting the pencil’: new concepts should, wherever possible, be introduced by virtue of their communicatively relevant relations to the most recent concept expressed.

In various experiments with patterns of the sort exemplified here (Levelt 1981*a, b*) we have gathered almost 4000 descriptions. Violations of the connectivity principle are quite rare: they never occur for patterns that are themselves linear, as in figure 1*a*; their only noticeable occurrence is where there are loops, as in figure 1*c*, but even there they are relatively infrequent. Connectivity is also a desirable property for the listener, because the new information can be linked to the most recent items, which will normally still be available in working memory.

It is, of course, not always possible for the speaker to introduce new items in a connected way without repeating old ones. If the pattern is hierarchical, as in figure 1*b*, the a.t.n. chooses one or the other exit arc of the choice node in a non-deterministic way; when it comes to the end of the branch it jumps back to the choice node to describe the other branch. This return jump violates the connectivity principle. The only way to preserve connectivity would be to retrace all the old items and to return step-by-step to the choice node. This is exactly the way

that returns are dealt with in the other a.t.n. model, which is not discussed here. The principled issue is this: when choice items are returned to by way of a jump, i.e. in disconnected way, as with the a.t.n. of figure 2, how does the speaker keep track of the returns to be made? If choice items are embedded, as in figure 1*b*, i.e. if the speaker reaches a new choice node before having returned to the earlier one, how is he going to schedule his returns? Does he return to the former one first, or the latter?

The second major principle says that *returns to choice items are made in first-in-last-out fashion*. The a.t.n. of figure 2 is equipped with a push-down stack where return addresses are stored one on top of the other, as they come in. Coming to the end of a linear branch, control jumps back to the top item on store. This is recursively done till the stack is empty. Another way of expressing the principle is to say that it minimizes the size of return jumps. This second process-principle seems to be quite robust as well. We found less than 3% violations in 297 descriptions of patterns involving embedded, and multiply embedded, choice nodes. It is likely, but not yet empirically demonstrated, that this way of ordering return moves is also advantageous to the listener; the corresponding a.t.n. model that we have made for the listener shows the same push-down property.

Maximization of connectivity, and first-in-last-out return to choice items, are the main principles on which the non-deterministic part of the linearization model is based. Together, they give linearization the 'depth-first' character that is so typical for human problem-solving (Newell & Simon 1972). Let us now turn to the probabilistic part. The model so far was non-deterministic in that it did not specify the order of choice at a choice item: that is, which branch will come first in the speaker's linear order, which one he will take after return, etc. The probabilistic part of the model predicts a speaker's tendencies or preferences in this respect. Again, the model's details are based on a principle of quite general character, which should be applicable to any complex domain of discourse.

The third major principle says that a speaker will tend to order his choices at a multiply branching item in such a way as to *minimize the load of memorizing return addresses*. This principle can best be exemplified by splitting it up in two parts, the first part to do with the *duration* of memory load, the second with *size* of load.

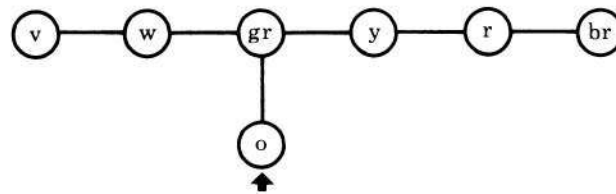

FIGURE 3. Pattern for testing minimization of duration of memory load. (Colours have been replaced by initials of colour names.)

Figure 3 exemplifies the case of minimization of duration. When arriving at the green choice node, the speaker can choose either to take the left branch first, or to begin with the right branch. In both cases he will later have to return to the green choice node to describe the other branch. But there is a difference: if the longer right branch is described first, the speaker will have to keep in mind the return address longer than if the shorter left branch is described first. It was therefore predicted that in this and similar cases there would be a higher probability for the

speaker to order choices from shorter to longer branches. In the experiments we found a clear confirmation of these prediction (Levelt 1981*b*).

Minimization of size of load can be illustrated with the pattern in figure 4. Here again there is a choice at the green node, but now the number of elements to be described is the same to the left and the right. The two branches differ, however, in that the right one contains another choice node. If the speaker were to describe this right branch first, then at some moment he would not only have to keep the first green choice node in mind as a return address, but also the second yellow node. This will not be so if the left branch is described first, since after having returned to the green choice node this can be released from memory, and there will thus be no moment where the speaker will have to keep track of two different nodes to return to. For

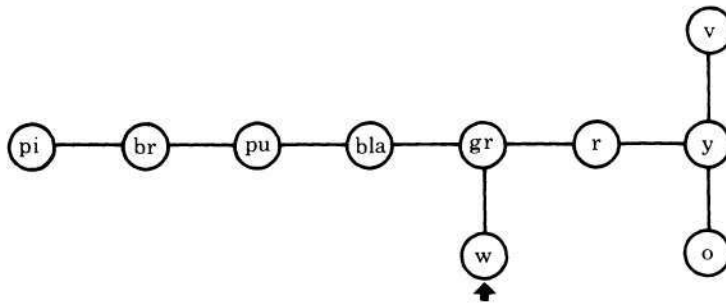

FIGURE 4. Pattern for testing minimization of size of memory load.

this and similar patterns we thus predicted a higher probability of describing simpler before more complex branches. This, again, was clearly confirmed in the experiments.

Note that these minimization strategies can be advantageous to the listener as well. If the listener is aware of the speaker's intention to return to an item at a later point in the discourse, then also the listener will try and keep track of these return addresses. This awareness on the part of the listener may be the result of more or less explicit cues in the speaker's wording, ranging from explicit mention ('we will return to this crossing point') to the use of more implicit modal expressions ('here you may go right'). If the listener can guess that a return will be made, the speaker's load minimizing strategies will also reduce effort for the listener.

To summarize the process-related principles, our conjecture is, first, that the speaker will be maximally connective when introducing new items of information, secondly, that he will return to choice items in inverse order, and finally, that he will order his paths from a choice item in such a way as to minimize keeping track of return addresses. It is interesting to observe that the combination of these principles is formally equivalent to what is known as Yngve's depth hypotheses (Yngve 1961). Yngve predicted maximization of right-branchingness for syntactic structures given the speaker's processing restrictions. Similarly, the present theory of linearization predicts maximization of right-branchingness for discourse structures, at least in so far as discourse is affected by processing restrictions. The arguments that Miller & Chomsky (1963) formulated against Yngve's theory, namely that the listener's processing requirements would favour left-brachingness, do not hold for the linearization theory: as we have pointed out, each of the principles may be advantageous for the listener as well. The empirical issue for a general theory of linearization is therefore to show a predominance of right-brachingness for discourse structures. We have shown this to hold for the present domain of spatial patterns, but we have no more than anecdotal evidence to this effect for other domains of discourse.

LINEARIZATION AND THE ORAL MODALITY OF LANGUAGE

What is the origin of the speaker's linearization problem? There is an obvious and rather trivial answer to this question. It is that the requirement to linearize is due to the oral modality of language: our vocal apparatus is not equipped for the simultaneous expression of complex information. Even if one agrees that some simultaneity of expression can be observed in coarticulation within and between syllables, or more clearly in the parallel expression of segmental and suprasegmental information, one would also have to admit that it is impossible to utter two or more sentences at the same time.

Still, there is reason to suppose that the linearization requirement is modality-independent, having more to do with our limited abilities in dealing with propositional information than with the technical restrictions of our vocal apparatus. There are two reasons worth mentioning: the first is that even if the speaker could miraculously speak with two voices simultaneously, the listener would be quite unable to cope with it. A long and impressive tradition of experimentation by Broadbent and his associates (see Broadbent 1971) has left no doubt that listeners have great difficulty in dealing with simultaneously spoken sentences. This occurs even when the utterances are dichotically presented, one to the left and one to the right ear. The argument that such speakers do not exist, and that listeners have thus no experience with this situation, is invalid: it is quite normal and quite frequent to be confronted with the simultaneous speech of several speakers. But the way in which humans deal with this 'cocktail party' situation is to attend selectively to only one speaker at any one moment.

The second reason is an even more compelling one. There are natural languages that do not make use of the oral-auditory modality, and which could, technically, allow for simultaneity of utterances. These are the native sign languages of the deaf. In American Sign Language (A.S.L.), and probably in all sign language, a sign can be made by either hand; there is free alternation. Therefore, nothing would prevent simultaneous signing with both hands. I have, in fact, observed various instances of simultaneous signing. In most cases the one hand holds a static classifier while the other hand signs the focal information, which entertains some relation to this classifier. The first hand therefore has an anaphoric function, not unlike the deictic function of a pointing gesture when we say 'there is the book'. In one case I observed the use of a common noun by one hand and the simultaneous utterance of a relative clause by the other hand. So some simultaneity can be observed in the use of A.S.L., but at the same time there is no doubt that it is ungrammatical in A.S.L. to sign two complete sentence tokens simultaneously (see Levelt (1980) for further discussion of these issues). We do not know whether the native A.S.L. observer would be able to comprehend simultaneous utterances; these experiments have never been done. But though the visual system seems to be designed for parallel processing, one should not expect positive results. The situation will probably be no better than for simultaneous reading tasks. There, we know it is sometimes possible to register single words in parallel (Willows & MacKinnon 1973), but there is no indication of simultaneous processing of sentence-type units.

With these remarks I shall return to the Ramist position that I endorsed in the Introduction. The issue of linearization has to be dealt with in the realm of *ratio*, the faculty of thought, not in the realm of *oratio*, the faculty of speech (for further experimental evidence relating to this distinction, see Levelt & Maassen (1981)). The requirement to linearize is an attentional one that applies equally well to the use of languages that do not involve speech as to any thought

process involving propositional information, such as doing arithmetic, playing chess, or planning a lecture on the speaker's linearization problem.

I am grateful to Else Barth, Gerard Kempen, William Marslen-Wilson and Gabriel Nuchelmans for discussions and comments in connection with this paper.

REFERENCES (Levelt)

- Becker, A. L. 1980 Text-building, epistemology, and aesthetics in Javanese shadow theatre. In *The imagination of reality* (ed. A. Becker & A. Yengoyan). Norwood: Ablex.
- Broadbent, D. E. 1977 *Decision and stress*. London: Academic Press.
- Collins, A., Warnock, E. H. & Passafiume, J. J. 1975 Analysis and synthesis of tutorial dialogues. In *The psychology of learning and motivation* (ed. G. H. Bower), vol. 9. New York: Academic Press.
- Fodor, J. A. 1975 *The language of thought*. Hassocks: Harvester Press.
- Gazdar, G. 1979 *Pragmatics*. London: Academic Press.
- Gazdar, G. 1980 Pragmatic constraints on linguistic production. In *Language production* (ed. B. Butterworth). London: Academic Press.
- Kempen, G. & van Wijk, C. 1981 Leren formuleren. *Tijdschr. Taalbeheers.* 3, 32–44.
- Kempton, R. M. 1975 *Presupposition and the delimitation of semantics*. Cambridge University Press.
- Klein, W. 1979 Wegauskünfte. *Z. LitWiss. Ling.* 9, 9–57.
- Klein, W. 1981 Some aspects of route directions. In *Speech, place, and action. Studies in deixis and related topics* (ed. R. J. Jarvella & W. Klein). Chichester: Wiley.
- Levelt, W. J. M. 1967 *Over het waarnemen van zinnen*. Groningen: Wolters.
- Levelt, W. J. M. 1980 On-line processing constraints on the properties of signed and spoken language. In *Signed and spoken language: biological constraints on linguistic form* (ed. U. Bellugi & M. Studdert-Kennedy). Weinheim: Chemie.
- Levelt, W. J. M. 1981a Cognitive styles in the use of spatial direction terms. In *Speech, place, and action. Studies in deixis and related topics* (ed. R. J. Jarvella & W. Klein). Chichester: Wiley.
- Levelt, W. J. M. 1981b Linearization in describing spatial networks. In *Processes, beliefs, and questions* (ed. S. Peters & E. Saarinen). Dordrecht: D. Reidel.
- Levelt, W. J. M. & Maassen, B. 1981 Lexical search and order of mention in sentence production. In *Crossing the boundaries in linguistics. Studies presented to Manfred Bierwisch* (ed. W. Klein & W. J. M. Levelt). Dordrecht: D. Reidel.
- Linde, C. & Labov, W. 1975 Spatial networks as a site for the study of language and thought. *Language* 51, 929–939.
- Lyons, J. 1977 *Semantics*, vol. 2. Cambridge University Press.
- Mandler, J. M. & Johnson, N. S. 1977 Remembrance of things parsed: story structure and recall. *Cogn. Psychol.* 9, 111–151.
- Miller, G. A. & Chomsky, N. 1963 Finitary models of language users. In *Handbook of mathematical psychology* (ed. R. D. Luce, R. R. Bush & E. Galanter), vol 2: New York: Wiley.
- Munro, A. 1977 Speech act understanding. Ph.D. dissertation, University of California, San Diego.
- Newell, A. & Simon, H. A. 1972 *Human problem solving*. Englewood Cliffs, N.J.: Prentice Hall.
- Nuchelmans, G. 1980 *Late-scholastic and humanist theories of the proposition*. Amsterdam: North-Holland.
- Ong, W. J. 1974 *Ramus, method, and the decay of dialogue*. New York: Octagon.
- Osgood, C. E. 1980 *Lectures on language performance*. New York: Springer.
- Ramus, P. 1546 *Dialectici commentarii tres auctore Audomaro Talaeo editi* (translation by W. J. Ong (1974)), pp. 83–84.
- Schank, R. & Abelson, R. 1977 *Scripts, plans, goals and understanding*. Hillsdale: Erlbaum.
- Tullius, M. ca. 85 B.C. *Ad Herennium* (translated and edited by H. Caplan (1954)). Cambridge, Massachusetts: Harvard University Press.
- Ullmer-Ehrich, V. 1979 Wohnraumbeschreibungen. *Z. LitWiss. Ling.* 9, 58–83.
- Ullmer-Ehrich, V. & Koster, C. 1981 Discourse organization and sentence form. The structure of static arrangement descriptions. Unpublished, Max-Planck-Institut für Psycholinguistik, Nijmegen.
- Willows, D. M. & MacKinnon, G. E. 1973 Selective reading: attention to the 'unattended' lines. *Can. J. Psychol.* 27, 292–304.
- Wunderlich, D. & Reinelt, R. 1981 How to get there from here. In *Speech, place, and action. Studies in deixis and related topics* (ed. R. J. Jarvella & W. Klein). Chichester: Wiley.
- Yngve, V. H. 1961 The depth hypothesis. In *Structure of language and its mathematical aspect. (Proc. 12th Symposium in Applied Mathematics)* (ed. R. Jacobson). Providence, R.I.: American Mathematical Society.

Discussion

R. B. LE PAGE (*Department of Language, University of York, U.K.*). I was interested in this paper since it seemed that it might offer some insight into the processes of pidginization with which I am concerned. Linguistic simplification is often cited as one of the universal processes that take place in a contact situation leading to the formation of a pidgin. The trouble is that there is no overall measure of linguistic complexity, so that simplification of one kind often leads to greater complexity of another. Is it not strange that all the subjects in this experiment arrived at the same kind of resultant of the varying possibilities for simplicity? Suppose that I described figure 4 by likening it to a map of the Central London Underground line, with access say from Adlwyck to Green in the west–east sequence Pink, Brown, Purple, Black, Green, Red, Yellow, and a north–south spur from the eastern Yellow. For a member of my culture this use of a cultural stereotype – a map – would make recognition very easy, even though it might to others seem more complex than the linear sequences used by Professor Levelt's subjects.

W. J. M. LEVELT. In my paper I specified two kinds of determinants of linearization: those having to do with mutual knowledge about the topic of discourse, and those related to the economy of 'book-keeping', or working memory. Professor Le Page's example belongs to the first kind: in London a speaker may assume common knowledge of Underground trajectory maps, and use the stereotype to encode the pattern. Such knowledge cannot be assumed in Nijmegen, where the experiment was run. Still, Professor Le Page touches upon two important questions to which my present findings provide no definite answers. The first is how speakers in a particular culture decide on a stereotypical way of expressing the information: the very uniform ways of description that appear not only in our experiments but also in Linde & Labov's and in other studies show that there must exist very strict criteria in a given speech community for selecting or rejecting a basis for description. In the pidgin situation the boundaries of mutual knowledge are very restricted, and I would suspect that a speaker would be particularly careful not to cross them, i.e. that his criteria would be very conservative. The second question is what happens if the use of a particular stereotype would lead to violations of connectivity, or other book-keeping principles, as in the Underground example. The empirical basis of my experiments is too limited to answer this question, but we have observed cases where speakers try to preserve both, so for instance by saying 'This is like a big T', and then resorting to a fully connected description.

H. C. LONGUET-HIGGINS, F.R.S. (*Laboratory of Experimental Psychology, University of Sussex, U.K.*). In inviting his subjects to describe the spatial layout of the graphs, Professor Levelt instructed them to begin at the node marked with an arrow. Might this not have predisposed them to giving a description based on a quasi-temporal exploration of the graph?

W. J. M. LEVELT. It was essential, for the experimental testing of our models, to fixate the starting node. This may indeed have induced a temporal way of description in our subjects. Still, many subjects did give non-temporal structural information in spite of the arrow, but even then they almost always kept to the predicted order of mention. It should, furthermore, be observed that very similar touring strategies occurred in Linde & Labov's study of apartment descriptions, in which no starting point was indicated to the informant.