

The Specific Heats, C_{σ} , and C_V , of Compressed and Liquefied Methane*

B. A. Younglove**

Institute for Basic Standards, National Bureau of Standards, Boulder, Colorado 80302

(January 30, 1974)

The specific heats, C_{σ} , of saturated liquid methane have been measured at 66 temperatures in the temperature range 95–187 K. The specific heats at constant volume, C_V , have been measured at 20 densities ranging from 0.8 to 2.8 times the critical density, at temperatures between 91 and 300 K, and at pressures to 330 bar (at 280 PVT states in all). The uncertainty of most of the measurements is estimated to be less than 0.5 percent, except near the critical point. These measurements were performed primarily to provide input data for accurate thermodynamic properties data calculations for liquid methane. They are believed to be the most comprehensive specific heat measurements available for pure compressed gaseous and liquid methane.

Key words: Constant volume; heat capacity; liquid; saturated liquid; specific heat; methane.

1. Introduction

For the calculation of fluid thermodynamic properties such as internal energy, enthalpy, entropy, and velocity of sound, at temperatures less than the critical point, one needs either the latent heat of vaporization or specific heat along a path traversing the temperatures of interest. Heat capacity measurements are much easier than latent heat measurements and the specific heat measurements are not restricted to the liquid-vapor curve but can be made covering temperatures and densities in the single phase fluid region as well.

For methane, specific heat of the saturated liquid, C_{σ} , was measured from 95 to 187 K, and specific heat at constant volume, C_V , was measured on 20 isochores with densities ranging from 8 mol/l to 28 mol/l, temperatures from 90 to 300 K, and pressures to 330 bar [1].¹

2. Apparatus

The specific heats were obtained using a constant volume adiabatic calorimeter, as described previously by Goodwin [2]. Basically, it consists of a thin spherical stainless-steel sample holder bearing a heater and platinum resistance thermometer and enclosed in an adiabatic shield. The calorimeter and cryostat are shown in figure 1. The refrigerant was liquid nitrogen.

*This work was carried out at the National Bureau of Standards under the sponsorship of The American Gas Association.

**Present address: Cryogenics Division, National Bureau of Standards, Boulder, CO 80302.

¹ Figures in brackets indicate the literature references at the end of this paper.

The versatility of this instrument is demonstrated in that it has been used with very minor modifications for the C_V and C_{σ} measurements of hydrogen [3, 4], oxygen [5, 6], fluorine [7, 8], and in this work on methane. These measurements cover temperatures from 14 to 300 K and pressures to 330 bar.

The thermometer was calibrated by the NBS Temperature Section. Temperatures are on the IPTS-68 scale. The temperature of the adiabatic shield and guard ring are controlled to the sample temperature with difference thermocouples and automatic power regulation. Heat exchange to the sample holder is considered negligible.

The sample used was 99.99 percent methane. Impurities as analyzed by the supplier in ppm were $\text{CO}_2 < 10$; O_2 , 4; N_2 , 12. A molecular sieve in an ice bath served to ensure removal of water vapor present in the sample.

3. Procedure

In essence, the specific heat C_V is calculated from the measured parameters as follows. The total heat capacity is determined as the ratio of the heat input ΔQ to the temperature increase ΔT brought about by applying a very stable power source to a resistor attached to the calorimeter sample holder, for an elapsed time Δt . The heat capacity of the empty sample holder C_0 is then subtracted off. It, of course, was previously measured in exactly the same way except with the sample space pumped to a vacuum. The difference of these two quantities is the heat capacity of the methane sample. The specific heat is

TABLE 1. Specific heat of saturated liquid methane, C_{σ} or C_{SAT} ; specific heat at constant volume of saturated liquid calculated, C_V ; specific heat of the two phase (liquid-vapor) system, C_2 ; heat capacity of the calorimeter (empty) C_0 , and heat capacity of the calorimeter (full) $\Delta Q/\Delta T$ or DQ/DT , with temperature, pressure, density, and temperature increment, DT

ID	Temp K	Press bar	Dens mol/l	DT K	DQ/DT J/K	C_0 J/K	C_2 J/mol · K	C_V J/mol · K	C_{sat} J/mol · K
201	95.402	0.209	27.755	3.657	133.482	46.671	54.418	34.274	54.240
401	95.846	.219	27.718	5.799	139.159	46.881	54.252	34.103	54.131
202	99.021	.311	27.450	3.574	135.870	48.348	54.864	34.169	54.647
302	101.651	.409	27.224	6.638	141.300	49.520	55.058	34.016	54.877
402	101.961	.422	27.198	6.420	143.111	49.656	54.943	33.883	54.790
203	102.574	.448	27.145	3.524	137.905	49.923	55.152	33.898	54.896
204	106.891	.673	26.767	5.110	140.924	51.750	55.899	33.941	55.602
303	108.219	.758	26.649	6.495	145.302	52.293	55.794	33.710	55.583
403	108.800	.797	26.597	7.236	146.902	52.528	55.483	33.349	55.315
205	112.604	1.097	26.254	6.273	144.013	54.022	56.410	33.478	56.075
304	115.165	1.343	26.019	7.386	149.404	54.988	56.638	33.391	56.434
206	119.117	1.802	25.649	6.702	147.576	56.412	57.144	33.041	56.810
305	122.474	2.278	25.327	7.194	153.257	57.561	57.404	32.862	57.287
405	123.367	2.419	25.240	7.498	154.829	57.858	57.008	32.389	56.996
207	125.766	2.830	25.005	6.568	151.006	58.636	57.899	32.534	57.645
406	130.765	3.852	24.500	7.297	158.819	60.171	57.992	32.000	58.245
208	132.274	4.209	24.343	6.430	154.477	60.612	58.834	32.162	58.774
1001	132.751	4.326	24.293	5.117	122.552	60.750	62.894	32.148	58.879
902	135.455	5.038	24.007	4.538	137.072	61.512	60.813	31.499	58.930
1002	137.805	5.723	23.752	4.973	125.195	62.151	64.157	31.650	59.729
903	139.970	6.412	23.513	4.476	139.223	62.720	61.570	30.986	59.698
801	144.305	7.971	23.017	4.019	141.250	63.808	62.323	30.460	60.560
904	144.401	8.009	23.005	4.386	141.728	63.831	62.689	30.797	60.929
802	148.500	9.725	22.514	4.371	143.789	64.800	63.565	30.407	62.033
905	148.881	9.896	22.467	4.316	143.807	64.888	63.509	30.230	62.005
1003	150.824	10.807	22.224	4.332	133.134	65.326	68.994	31.449	64.014
803	152.809	11.798	21.969	4.247	146.566	65.763	65.022	30.468	63.898
906	153.157	11.978	21.924	4.229	146.775	65.838	65.129	30.459	64.048
1004	155.542	13.267	21.606	4.941	135.238	66.345	70.092	30.518	65.246
804	157.043	14.128	21.401	4.180	148.588	66.657	65.926	29.932	65.435
907	157.355	14.312	21.358	4.167	148.747	66.721	66.001	29.899	65.569
1005	159.127	15.388	21.107	4.035	137.307	67.080	71.446	30.244	66.905
805	161.181	16.707	20.808	4.095	151.123	67.486	67.294	29.823	67.733
908	161.483	16.908	20.763	4.088	151.284	67.545	67.375	29.793	67.898
1006	163.136	18.036	20.512	3.982	138.917	67.864	72.280	29.161	68.379
1402	163.782	18.492	20.412	5.441	153.354	67.987	68.702	30.257	69.936
806	165.249	19.556	20.179	4.036	153.713	68.263	68.749	29.746	70.534
1407	165.128	19.467	20.199	5.131	154.144	68.240	69.132	30.171	70.865
909	165.548	19.779	20.131	4.043	153.880	68.318	68.838	29.719	70.745
1007	166.549	20.536	19.967	2.738	141.994	68.503	74.756	29.907	71.756
807	169.253	22.687	19.505	3.963	156.273	68.991	70.216	29.609	73.960
910	169.565	22.945	19.450	3.949	156.656	69.047	70.480	29.743	74.411
1220	170.157	23.440	19.344	7.335	138.896	69.151	79.614	29.404	74.696
1008	170.197	23.474	19.336	4.297	144.726	69.159	76.862	30.033	75.369
1408	170.251	23.520	19.327	5.020	157.666	69.168	71.213	30.181	75.575
1403	171.097	24.243	19.172	5.271	158.018	69.316	71.376	29.980	76.320
808	173.180	26.094	18.773	3.890	159.054	69.675	71.898	29.577	78.540
911	173.480	26.369	18.714	3.873	159.572	69.727	72.273	29.813	79.194
701	173.505	26.392	18.709	5.002	141.928	69.731	81.284	29.262	78.678
1216	174.032	26.880	18.603	7.180	141.932	69.820	82.310	29.445	79.623
1009	174.429	27.252	18.522	4.167	148.478	69.887	79.930	30.556	81.334
1409	175.228	28.012	18.355	4.900	161.213	70.021	73.374	30.069	82.128
1404	176.295	29.051	18.125	5.118	162.367	70.198	74.158	30.312	84.253
809	177.029	29.782	17.961	3.811	162.720	70.318	74.323	30.097	85.466
1221	177.420	30.177	17.872	6.968	146.364	70.382	86.720	31.201	87.382
702	177.902	30.670	17.760	3.799	145.938	70.461	84.967	29.552	86.790
1010	178.557	31.349	17.603	4.090	151.355	70.567	82.156	29.861	88.641
1200	180.613	33.553	17.078	5.694	148.814	70.895	88.923	30.420	95.067
1217	181.034	34.018	16.963	6.825	149.125	70.961	89.202	30.254	96.349
703	181.645	34.702	16.790	3.688	150.564	71.057	89.496	30.451	98.844
1011	182.572	35.759	16.516	3.940	156.745	71.201	86.983	31.025	103.442
1222	184.222	37.703	15.976	6.616	154.219	71.454	94.445	31.451	113.330
704	185.271	38.982	15.588	3.549	156.464	71.613	95.503	31.421	121.769
1201	186.127	40.050	15.236	5.329	158.456	71.742	98.948	32.509	132.153
1012	187.577	41.915	14.530	6.026	151.278	71.957	80.630	16.306	141.359
1218	187.633	41.988	14.499	6.358	160.079	71.965	100.540	30.050	156.489

obtained by dividing the heat capacity by the amount of methane, N .

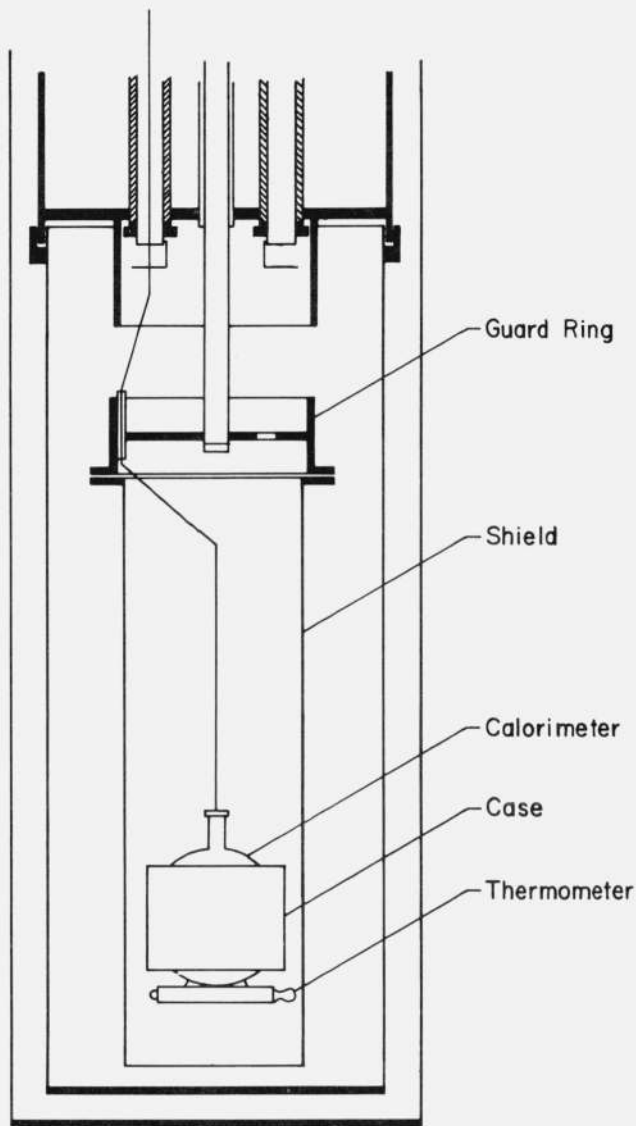

FIGURE 1. Calorimeter and cryostat.

Actually, several corrections are made to the above. Since the sample holder is a thin stainless steel sphere (~ 0.16 mm wall thickness and 5 cm diam), it stretches as the pressure increases. This allows work to be done by the methane due to the increase of the sample volume. This correction [4, 5, 6], developed by Walker [9], ranges from 0.5 to 5 percent of the resulting C_V value. However, it can be made accurately.

Of the three variables, pressure, temperature, and density, only temperature is measured during the measurement of an isochore. The pressure and temperature are measured at filling and the density calculated from the PVT surface [10]. The amount of methane, N , is calculated from the volume $V(T, P)$ as previously determined [3, 5]. The density for each C_V measurement is calculated from the filling density

after correcting for sample holder expansion and the amount compressed into the filling capillary [6].

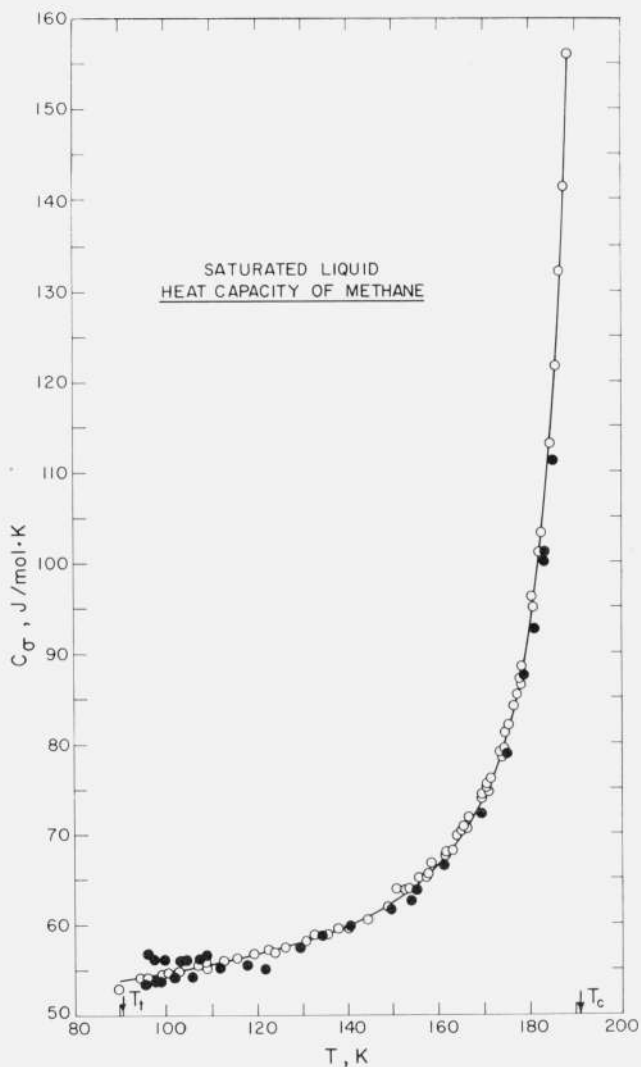

FIGURE 2. Specific heat of the saturated liquid for methane, this work, \circ , the measurements of Wiebe and Breevort \bullet [12].

In the case of the C_σ measurement, the two phase heat capacity (liquid and gas) is first determined as the difference of the total heat capacity (DQ/DT , column 6 of table 1) and the empty heat capacity (C_0 , column 7) and the result divided by the total amount of sample (C_2 , column 8). Then the effects of the latent heat of vaporization and heat absorbed by the vapor are subtracted [3, 5, 7] to give C_σ (column 10). This type of correction is derived by Hoge [11].

The temperature increment, resulting from a constant power input over a time Δt , is evaluated at the middle of the heating interval by extrapolating the temperature drift rates evaluated just before heating and after an equilibrating time has elapsed (about 20 min). Care was taken to reduce the effects of noise on drift rate by taking many (10 to 20) measurements of time and temperature.

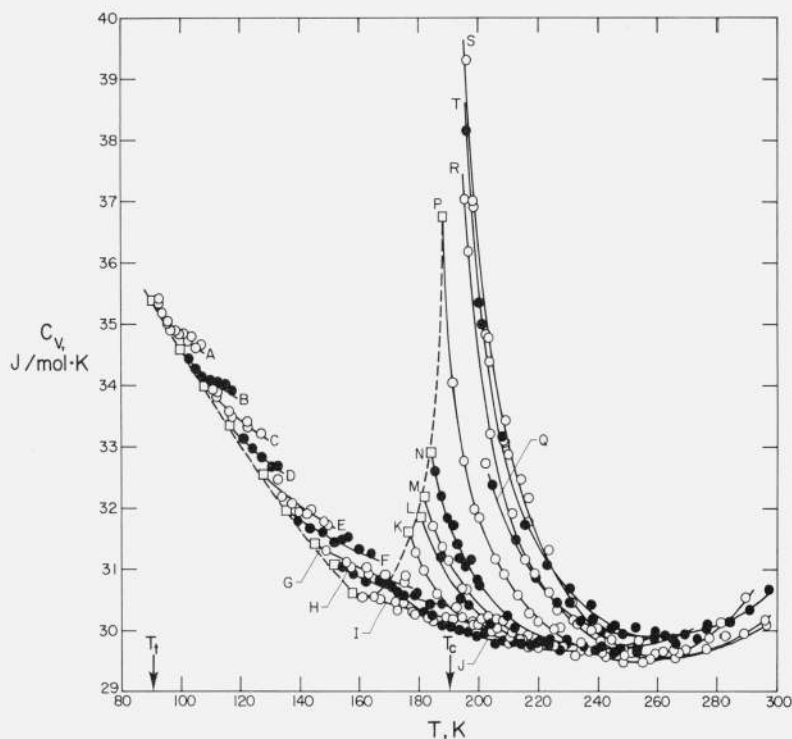

FIGURE 3. Specific heat at constant volume of methane on isochores versus temperature.

Open and closed circles on alternate isochores are for clarity.

A—28.0 mol/l,	B—27.4 mol/l	C—26.7 mol/l
D—25.8	E—24.7	F—24.0
G—23.0	H—22.1	I—21.3
J—19.5	K—18.0	L—17.0
M—16.7	N—16.0	P—14.4
Q—13.1	R—13.1	S—11.8
T—7.9		

4. Results

The specific heat of the saturated liquid was measured for 66 temperatures. The lowest was 95 K (triple point, 90.68 K) and the highest 187 K (see fig. 2 and table 1). The estimated uncertainty in the measured value of C_σ is about 0.5 percent generally but increasing to about 5 percent within a few Kelvin of the critical point. The data of Weibe and Breevort [12] are shown for comparison as the closed circles. Their measurements agree remarkably well with the new data, considering the state of the art at that time.

Figure 3 and table 2 show C_V as a function of temperature for the various isochores. The dashed line is the locus of C_V for saturated liquid as extrapolated from the C_V measurements. The uncertainties in C_V are the same as for C_σ . Densities Q, R, S, and T have uncertainties as large as 5 percent near critical temperature, indicated as T_c on figure 3. Density T is 22 percent less than critical density.

Figure 4 shows C_V at saturation. The circles are values extrapolated from the C_V data and the triangles are computed from C_σ data by adding the term $T \left(\frac{\partial P}{\partial T} \right)_v \frac{dV}{dT}$. These derivatives, evaluated analytically from a representation of the PVT surface [2], introduce the scatter and the lowering of the values from the extrapolated values which have essentially the same accuracy as the measured C_V values.

Comparison was made with the C_p data of Jones et al. [17] on their 2000 lb/in² (136.7 bar) by interpolation of the C_V data and adding the PVT contribution. Figure 5 shows the close agreement of the two sets of data. The other curve is calculated from spectroscopic heat capacities together with the PVT term above critical temperature, (T_c). Below the critical temperature, latent heats must also be used. The discontinuity is, of course, at T_c .

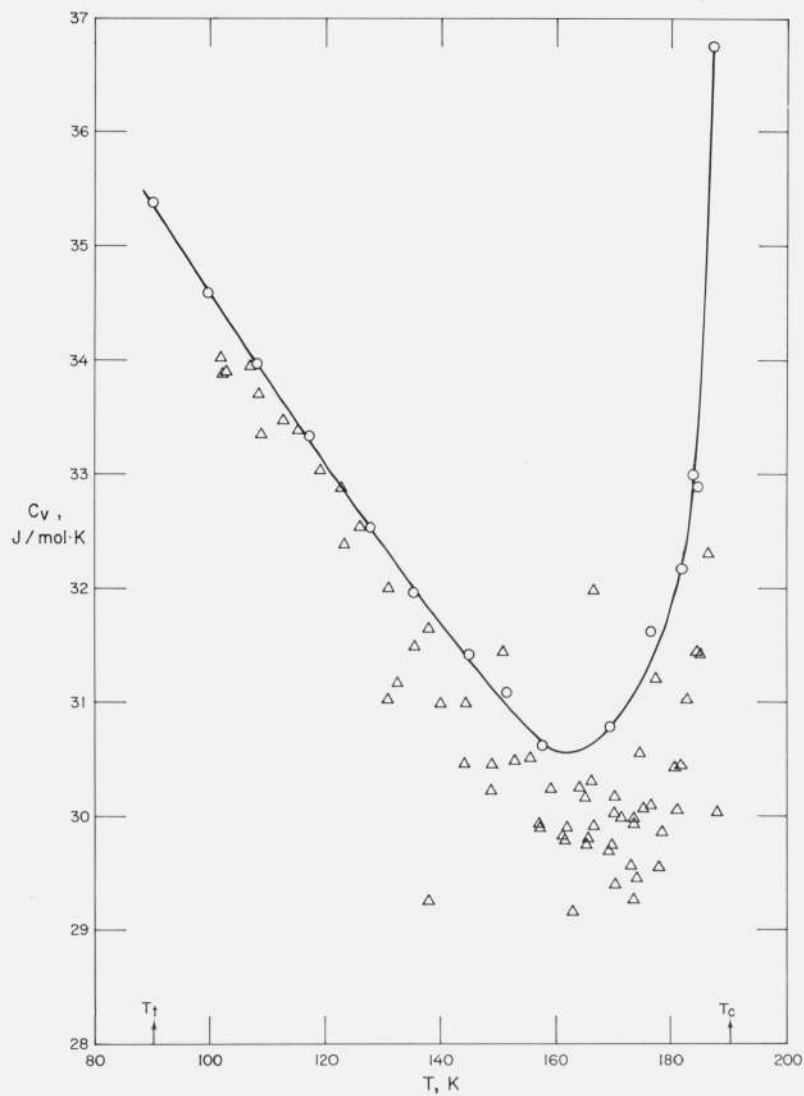

FIGURE 4. C_v of liquid methane evaluated at the liquid-gas boundary.

Extrapolation of C_v (O), calculation from C_p using PVT surface (Δ).

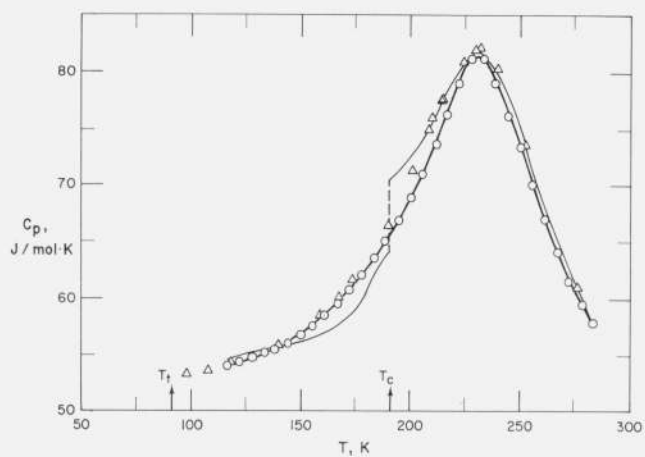

FIGURE 5. Comparison of methane C_p from Jones, et al. (—O—); to C_p calculated from C_v data, this work (Δ), and to C_p calculated from PVT data (—).

TABLE 2. Specific heat at constant volume, C_v , of methane; heat correction for calorimeter expansion C_1 , heat capacity of empty calorimeter, C_0 , total heat capacity of calorimeter (full) $\Delta Q/\Delta T$ or DQ/DT , with temperature, pressure, density, and temperature increment, DT

ID	Temp K	Press bar	Den mol/l	DT K	DQ/DT J/K	C_0 J/K	C_1 J/mol · K	C_v J/mol · K
2209	200.342	56.917	7.991	7.542	94.477	73.734	0.166	35.351
2203	201.339	58.027	7.991	5.459	94.406	73.865	.167	35.004
2210	207.854	65.217	7.988	7.559	94.152	74.691	.170	33.153
2204	208.168	65.562	7.988	7.419	94.184	74.729	.170	33.141
2211	215.402	73.451	7.984	7.554	94.227	75.593	.175	31.732
2212	222.937	81.598	7.980	7.511	94.677	76.439	.182	31.046
2205	222.993	81.658	7.980	7.361	94.691	76.445	.182	31.059
2206	230.373	89.583	7.977	7.387	95.264	77.226	.189	30.698
2213	230.453	89.668	7.977	7.484	95.130	77.234	.189	30.455
2207	237.534	97.229	7.973	7.324	95.819	77.940	.195	30.419
2214	238.128	97.862	7.973	7.382	95.748	77.998	.196	30.198
2208	244.733	104.881	7.970	7.292	96.283	78.619	.202	30.045
2215	245.476	105.669	7.969	7.369	96.374	78.687	.203	30.084
2216	252.815	113.433	7.966	7.332	97.017	79.335	.210	30.067
2218	266.349	127.671	7.959	7.246	97.960	80.436	.222	29.785
1505	195.780	53.853	10.176	6.728	102.498	73.123	.185	39.325
1523	198.095	57.310	10.175	5.257	101.084	73.436	.189	36.999
1521	198.426	57.804	10.174	5.284	101.071	73.480	.189	36.921
1506	202.601	64.048	10.171	6.923	100.060	74.028	.194	34.818
1502	203.142	64.857	10.171	6.470	106.980	74.098	.195	44.032
1524	203.375	65.206	10.171	5.301	100.142	74.128	.196	34.793
1522	203.731	65.739	10.171	5.320	99.881	74.173	.197	34.382
1525	208.704	73.193	10.167	5.334	99.538	74.795	.203	33.078
1523	209.057	73.722	10.167	5.326	99.856	74.838	.204	33.447
1507	209.526	74.426	10.166	6.942	99.491	74.895	.203	32.879
1503	209.853	74.915	10.166	6.955	99.636	74.935	.204	33.020
1526	214.044	81.206	10.164	5.346	99.736	75.434	.211	32.476
1508	216.467	84.845	10.161	6.956	99.479	75.715	.213	31.750
1504	216.813	85.365	10.161	6.945	99.842	75.755	.214	32.185
1509	223.396	95.256	10.157	6.923	99.937	76.489	.223	31.318
1510	230.790	106.373	10.151	6.920	100.066	77.268	.233	30.432
1511	237.756	116.844	10.147	6.901	100.443	77.962	.242	29.998
1512	244.636	127.181	10.142	6.864	100.993	78.610	.251	29.857
1513	251.488	137.466	10.137	6.819	101.457	79.221	.261	29.650
1514	259.403	149.331	10.131	6.782	102.116	79.886	.271	29.632
1515	266.154	159.433	10.126	6.725	102.604	80.421	.280	29.560
1517	282.516	183.843	10.114	6.617	104.067	81.599	.301	29.922
1518	289.146	193.696	10.110	6.625	104.538	82.032	.310	29.964
1519	295.822	203.596	10.105	6.556	105.109	82.444	.319	30.170
219	195.627	55.318	11.838	9.621	105.430	73.102	.204	37.165
223	196.581	57.055	11.839	7.285	104.709	73.232	.209	36.177
224	203.924	70.601	11.832	7.393	103.134	74.198	.226	33.223
225	211.370	84.550	11.826	7.394	102.930	75.118	.242	31.908
205	215.626	92.584	11.822	8.023	102.779	75.618	.250	31.148
226	218.787	98.572	11.819	7.411	102.950	75.979	.256	30.922
206	223.653	107.819	11.815	8.022	103.224	76.517	.265	30.609
227	226.191	112.653	11.813	7.374	103.274	76.789	.270	30.347
207	231.675	123.117	11.808	7.947	103.685	77.359	0.279	30.155
228	233.566	126.729	11.806	7.338	103.858	77.549	.283	30.130
208	239.625	138.319	11.801	7.906	104.383	78.141	.293	30.043
229	204.923	140.803	11.800	7.311	104.171	78.264	.296	29.653
209	248.734	155.761	11.792	7.882	104.855	78.979	.309	29.604
210	257.453	172.459	11.784	9.556	105.552	79.726	.323	29.534
211	266.957	190.643	11.775	9.438	106.408	80.482	.339	29.632
212	276.534	208.934	11.766	9.341	107.186	81.187	.355	29.702
214	296.364	246.647	11.748	9.271	108.845	82.476	.388	30.098
301	204.751	77.746	13.088	7.244	105.556	74.303	.264	32.393
302	212.016	93.924	13.080	7.229	105.596	75.195	.282	31.485
303	219.265	110.242	13.073	7.214	105.859	76.033	.299	30.868
304	226.524	126.697	13.065	7.179	106.293	76.824	.315	30.478
305	234.072	143.881	13.057	7.166	106.784	77.600	.331	30.165
306	241.245	160.256	13.050	7.146	107.321	78.295	.347	29.985
307	248.387	176.580	13.042	7.078	107.969	78.948	.362	29.965
309	262.566	208.987	13.026	7.007	109.144	80.140	.391	29.918
310	276.780	241.398	13.011	6.874	110.608	81.204	.419	30.309
313	276.944	241.772	13.010	6.908	110.434	81.216	.419	30.114

TABLE 2. Specific heat at constant volume, C_v , of methane; heat correction for calorimeter expansion Cl, heat capacity of empty calorimeter, C_0 , total heat capacity of calorimeter (full) $\Delta Q/\Delta T$ or DQ/DT , with temperature, pressure, density, and temperature increment, DT —Continued

ID	Temp K	Press bar	Den mol/l	DT K	DQ/DT J/K	C_0 J/K	Cl J/mol · K	C_v J/mol · K
314	283.783	257.318	13.003	6.854	110.947	81.684	.433	30.147
311	290.591	272.756	12.995	6.847	111.617	82.124	.446	30.375
312	297.427	288.216	12.987	6.788	112.344	82.540	.460	30.687
501	191.539	52.228	14.388	7.056	108.595	72.531	.268	34.042
528	195.039	61.226	14.383	8.352	107.756	73.021	.281	32.765
502	198.638	70.602	14.379	7.127	107.453	73.509	.295	32.000
520	200.323	75.028	14.377	8.432	107.534	73.732	.299	31.860
503	205.816	89.577	14.371	7.131	107.532	74.437	.315	31.171
521	208.733	97.366	14.366	8.358	107.655	74.799	.321	30.940
504	212.954	108.696	14.362	7.102	107.804	75.306	.334	30.585
522	217.103	119.884	14.356	8.319	107.990	75.788	.347	30.292
505	220.066	127.901	14.353	7.075	108.187	76.123	.356	30.152
523	225.394	142.360	14.346	8.245	108.656	76.704	.369	30.032
506	227.167	147.180	14.344	7.039	108.887	76.892	.375	30.067
524	234.287	166.574	14.334	8.234	109.380	77.621	.392	29.826
507	234.417	166.928	14.335	6.969	109.372	77.634	.393	29.805
508	241.372	185.902	14.326	6.927	109.898	78.307	.411	29.647
525	242.493	188.962	14.324	8.159	109.939	78.412	.412	29.585
509	248.293	204.791	14.317	6.910	110.378	78.940	.428	29.485
510	255.197	223.622	14.308	6.870	111.009	79.538	.445	29.500
511	262.143	242.543	14.299	6.820	111.759	80.107	.461	29.656
514	265.537	251.779	14.294	7.970	112.059	80.373	.468	29.681
512	269.538	262.650	14.289	7.971	112.383	80.678	.478	29.689
515	273.495	273.386	14.284	7.928	112.890	80.969	.487	29.885
513	277.494	284.223	14.278	7.914	113.176	81.255	.497	29.877
516	281.439	294.892	14.273	7.875	113.651	81.527	.506	30.061
517	289.349	316.229	14.262	7.793	114.710	82.045	.524	30.557
701	187.947	51.088	16.104	7.172	110.110	72.012	0.350	32.038
707	188.669	53.498	16.103	6.957	110.164	72.118	.353	31.990
721	191.577	63.245	16.098	6.895	110.072	72.537	.367	31.543
702	195.118	75.188	16.093	7.178	110.019	73.032	.378	31.066
708	195.637	76.943	16.092	6.947	110.062	73.103	.380	31.040
720	199.140	88.833	16.087	6.859	110.111	73.576	.390	30.670
703	202.277	99.525	16.082	7.135	110.530	73.987	.397	30.670
709	202.632	100.738	16.082	6.943	110.308	74.032	.399	30.441
704	209.408	123.943	16.071	7.112	110.909	74.881	.426	30.204
710	209.569	124.495	16.071	6.933	110.994	74.901	.427	30.258
711	216.494	148.306	16.060	6.873	111.429	75.718	.450	29.911
705	216.509	148.360	16.060	7.078	111.388	75.720	.450	29.875
712	223.352	171.937	16.049	6.816	112.095	76.484	.472	29.805
706	223.900	173.825	16.048	7.007	112.128	76.544	.473	29.780
713	230.437	196.359	16.038	6.824	112.675	77.232	.494	29.639
714	237.251	219.833	16.027	6.791	113.485	77.913	.515	29.729
715	244.048	243.213	16.016	6.758	113.994	78.556	.536	29.594
716	250.777	266.302	16.005	6.660	114.660	79.159	.557	29.627
717	257.424	289.044	15.994	6.627	115.322	79.724	.577	29.689
718	264.035	311.587	15.983	6.571	116.177	80.256	.597	29.944
719	270.623	333.970	15.972	6.544	116.590	80.759	.616	29.849
1601	185.501	42.477	16.038	2.172	110.226	71.648	.337	32.608
1602	187.587	49.323	16.035	2.006	110.069	71.959	.348	32.198
1603	189.591	55.934	16.032	2.009	109.944	72.252	.358	31.832
1604	191.595	62.582	16.029	2.004	110.119	72.539	.361	31.732
1618	192.871	66.824	16.024	6.135	109.928	72.719	.367	31.410
1605	193.605	69.272	16.026	2.010	109.753	72.822	.377	31.163
1606	195.615	75.989	16.023	2.012	109.895	73.100	.383	31.041
1607	197.622	82.719	16.020	2.003	110.311	73.373	.389	31.157
1608	199.628	89.464	16.017	2.005	110.203	73.640	.396	30.831
1619	200.031	90.821	16.011	8.252	110.152	73.693	.391	30.746
1620	209.230	121.946	15.996	10.164	110.765	74.859	.419	30.246
1609	217.884	151.399	15.986	6.097	111.290	75.877	.452	29.793
1611	223.224	169.616	15.977	6.069	111.946	76.470	.469	29.830
1610	223.903	171.930	15.976	6.052	112.026	76.544	.471	29.834
1622	229.421	190.764	15.964	10.032	112.633	77.128	.484	29.842
1612	229.453	190.871	15.967	6.063	112.588	77.131	.488	29.795
1623	239.424	224.878	15.948	9.937	113.475	78.122	.515	29.681
1613	241.503	231.959	15.948	5.956	113.763	78.319	.525	29.748
1614	247.521	252.433	15.939	5.898	114.298	78.871	.544	29.715

TABLE 2. Specific heat at constant volume, C_V , of methane; heat correction for calorimeter expansion C1, heat capacity of empty calorimeter, C_0 , total heat capacity of calorimeter (full) $\Delta Q/\Delta T$ or DQ/DT , with temperature, pressure, density, and temperature increment, DT —Continued

ID	Temp K	Press bar	Den mol/l	DT K	DQ/DT J/K	C_0 J/K	C1 J/mol · K	C_V J/mol · K
1615	253.443	272.535	15.929	5.912	114.868	79.389	.562	29.742
1616	259.333	292.473	15.919	5.842	115.529	79.880	.579	29.869
1617	265.198	312.270	15.910	5.849	116.001	80.347	.597	29.856
1309	184.764	45.449	16.723	5.354	110.741	71.537	0.381	31.721
1301	187.826	56.698	16.717	6.932	110.769	71.994	.394	31.357
1310	190.103	65.099	16.714	5.347	110.862	72.326	.406	31.150
1302	194.733	82.255	16.706	6.892	110.968	72.979	.423	30.685
1311	195.445	84.904	16.706	5.344	111.063	73.077	.427	30.679
1303	201.094	105.956	16.696	5.855	111.252	73.833	.446	30.196
1323	202.937	112.841	16.693	6.031	111.551	74.072	.453	30.239
1312	206.062	124.532	16.688	5.287	111.919	74.468	.465	30.204
1304	206.122	124.756	16.689	4.249	111.707	74.475	.466	30.023
1324	208.680	134.336	16.683	5.477	112.228	74.792	.473	30.184
1305	210.401	140.788	16.681	4.330	112.079	75.001	.481	29.882
1313	211.348	144.339	16.679	5.286	112.322	75.115	.483	29.987
1325	214.143	154.818	16.674	5.464	112.494	75.446	.492	29.847
1306	215.024	158.123	16.673	4.934	112.592	75.549	.496	29.840
1314	216.658	164.252	16.670	5.219	112.889	75.737	.501	29.924
1326	219.582	175.218	16.665	5.433	112.992	76.069	.511	29.727
1327	225.003	195.545	16.655	5.423	113.635	76.662	.530	29.749
1317	232.337	223.009	16.643	5.178	114.228	77.426	.555	29.585
1318	237.657	242.891	16.633	5.448	114.856	77.952	.572	29.651
1319	243.097	263.174	16.624	5.401	115.579	78.468	.590	29.802
1320	248.519	283.339	16.614	5.387	115.951	78.960	.608	29.686
1321	253.921	303.370	16.604	5.359	116.619	79.430	.626	29.831
1322	259.304	323.264	16.595	5.339	117.189	79.878	.644	29.913
411	187.325	58.469	17.007	8.019	111.229	71.920	.416	31.221
401	193.924	83.993	16.997	6.900	111.328	72.867	.443	30.513
406	196.587	94.337	16.992	7.437	111.563	73.233	.452	30.399
413	203.953	123.025	16.978	7.970	112.216	74.202	.478	30.119
414	211.988	154.390	16.964	7.898	113.134	75.192	.507	30.033
415	219.901	185.282	16.950	7.850	113.769	76.104	.535	29.782
416	227.768	215.952	16.936	7.807	114.550	76.955	.562	29.698
417	235.598	246.397	16.922	7.735	115.435	77.751	.590	29.743
418	245.293	283.931	16.904	7.650	116.261	78.670	.623	29.635
419	252.926	313.338	16.890	7.598	117.007	79.345	.649	29.667
1801	178.581	37.972	18.086	3.069	112.484	70.571	.469	31.280
1802	181.649	51.836	18.080	3.085	112.625	71.057	.496	30.991
1803	186.224	72.545	18.068	6.089	112.813	71.756	.503	30.598
1804	192.299	100.083	18.056	6.060	113.438	72.639	.530	30.377
1805	198.354	127.540	18.044	6.039	113.922	73.471	.554	30.090
1806	204.379	154.828	18.032	6.010	114.564	74.256	.578	29.958
1807	210.370	181.915	18.019	5.964	115.132	74.998	.602	29.803
1808	216.641	210.187	18.006	5.923	115.821	75.735	.627	29.741
1809	222.620	237.053	17.994	5.886	116.615	76.404	.651	29.812
1810	228.488	263.318	17.982	5.854	117.179	77.031	.674	29.742
1811	234.304	289.242	17.970	5.825	117.723	77.623	.697	29.683
1812	240.990	318.901	17.955	5.797	118.614	78.271	.723	29.841
1709	172.603	40.302	19.500	6.087	114.035	69.577	0.596	30.637
1710	178.550	73.409	19.486	6.101	114.965	70.566	.608	30.586
1701	181.613	90.419	19.479	6.082	115.092	71.052	.636	30.306
1711	184.637	107.182	19.472	6.065	115.515	71.517	.650	30.262
1702	187.628	123.725	19.465	6.054	115.740	71.965	.663	30.094
1712	190.680	140.564	19.457	6.039	116.187	72.408	.676	30.082
1703	193.640	156.857	19.450	6.008	116.537	72.827	.690	30.021
1713	196.693	173.622	19.443	5.997	116.917	73.247	.704	29.980
1704	199.616	189.630	19.435	5.980	117.239	73.639	.717	29.918
1714	202.661	206.260	19.428	5.946	117.740	74.036	.731	29.976
1705	205.568	222.086	19.421	5.941	117.875	74.406	.745	29.798
1715	208.615	238.633	19.413	5.927	118.353	74.784	.759	29.854
1706	211.480	254.140	19.406	5.895	118.705	75.131	.772	29.844
1716	214.522	270.555	19.398	5.886	118.998	75.490	.787	29.783
1707	217.573	286.970	19.391	5.857	119.326	75.842	.801	29.752
1717	220.387	302.058	19.384	5.842	119.782	76.158	.814	29.837
1708	223.411	318.216	19.376	5.818	120.066	76.491	.829	29.789

TABLE 2. Specific heat at constant volume, C_v , of methane; heat correction for calorimeter expansion Cl, heat capacity of empty calorimeter, C_0 , total heat capacity of calorimeter (full) $\Delta Q/\Delta T$ or DQ/DT , with temperature, pressure, density, and temperature increment, DT —Continued

ID	Temp K	Press bar	Den mol/l	DT K	DQ/DT J/K	C_0 J/K	Cl J/mol · K	C_v J/mol · K
807	161.140	39.441	21.313	5.723	116.134	67.478	.746	30.544
801	165.189	68.515	21.299	6.791	116.981	68.251	.772	30.565
808	166.828	80.226	21.296	5.647	117.232	68.554	.798	30.507
802	171.921	116.429	21.279	6.676	118.171	69.459	.833	30.495
809	172.488	120.439	21.279	5.633	118.018	69.557	.831	30.336
810	178.091	159.906	21.262	5.566	118.950	70.491	.859	30.307
803	178.582	163.345	21.258	6.640	118.980	70.571	.859	30.275
811	183.640	198.640	21.244	5.532	119.742	71.365	.890	30.224
804	185.182	209.346	21.238	6.587	119.938	71.600	.896	30.193
812	189.153	236.787	21.227	5.487	120.631	72.188	.921	30.236
805	191.734	254.532	21.218	6.521	120.927	72.559	.933	30.175
813	194.626	274.322	21.210	5.456	121.445	72.964	.953	30.229
806	198.229	298.849	21.197	6.467	121.824	73.454	.971	30.139
814	200.078	311.376	21.193	5.439	122.044	73.700	.985	30.109
2109	153.984	30.846	22.126	4.385	117.420	66.016	.818	31.040
2101	157.876	62.103	22.113	4.327	118.099	66.827	.845	30.931
2102	162.200	96.526	22.098	4.314	118.875	67.684	.927	30.800
2103	166.497	130.432	22.083	4.273	119.755	68.493	.940	30.832
2104	170.767	163.847	22.069	4.251	120.349	69.259	.951	30.716
2105	175.011	196.789	22.054	4.233	120.874	69.985	.976	30.567
2106	179.314	229.914	22.040	4.211	121.698	70.688	1.003	30.615
2107	183.514	261.982	22.025	4.186	122.103	71.346	1.029	30.432
2108	187.701	293.689	22.011	4.164	122.834	71.976	1.056	30.468
1406	148.828	44.459	22.933	6.789	118.758	64.875	0.899	31.314
1407	155.536	104.131	22.907	6.633	120.057	66.344	1.015	31.098
1402	155.969	107.942	22.906	6.629	120.154	66.435	1.017	31.100
1401	156.936	116.449	22.900	7.882	120.264	66.635	1.020	31.042
1408	162.130	161.805	22.883	6.560	121.193	67.671	1.042	30.958
1403	162.555	165.498	22.881	6.564	121.222	67.753	1.043	30.925
1409	168.648	217.963	22.858	6.496	122.400	68.883	1.075	30.923
1404	169.076	221.618	22.856	6.499	122.320	68.960	1.078	30.826
1410	175.122	272.905	22.834	6.458	123.385	70.003	1.120	30.798
1405	175.530	276.347	22.832	6.440	123.626	70.071	1.123	30.898
2001	139.073	45.399	24.008	4.195	119.866	62.486	0.988	31.796
2002	143.270	88.569	23.990	4.184	120.961	63.554	1.146	31.655
2003	147.448	130.924	23.972	4.155	121.919	64.557	1.165	31.612
2004	151.599	172.491	23.954	4.133	122.597	65.498	1.191	31.437
2005	155.908	215.104	23.935	4.091	123.742	66.422	1.205	31.550
2006	160.011	255.209	23.917	4.084	124.120	67.256	1.236	31.258
2007	164.072	294.445	23.900	4.052	124.977	68.042	1.268	31.267
901	130.508	34.766	24.785	2.255	121.056	60.095	1.097	32.662
909	131.693	48.379	24.772	5.484	121.045	60.443	1.106	32.454
904	132.694	59.842	24.767	5.557	121.433	60.734	1.136	32.479
902	134.136	76.278	24.761	4.991	121.346	61.144	1.174	32.166
910	137.159	110.410	24.746	5.421	122.150	61.977	1.245	32.080
903	139.337	134.756	24.735	5.473	122.514	62.555	1.258	31.949
911	142.547	170.300	24.720	5.356	123.309	63.375	1.283	31.911
906	143.713	183.112	24.715	5.439	123.701	63.663	1.287	31.964
912	147.886	228.554	24.695	5.336	124.401	64.659	1.303	31.785
907	149.124	241.915	24.689	5.389	124.607	64.943	1.313	31.732
913	153.185	285.371	24.670	5.287	125.563	65.844	1.348	31.728
908	154.473	299.029	24.664	5.310	126.059	66.120	1.359	31.839
1201	121.160	64.484	25.872	3.070	122.005	57.118	1.274	33.145
1202	124.223	104.694	25.855	3.048	122.909	58.138	1.400	32.958
1203	127.262	144.001	25.838	3.035	123.532	59.107	1.420	32.757
1204	130.274	182.414	25.822	3.013	124.390	60.025	1.455	32.691
1101	110.867	44.963	26.655	5.194	121.731	53.349	1.309	33.910
1106	111.917	60.514	26.649	5.165	121.991	53.758	1.354	33.789
1103	111.855	59.603	26.649	5.215	121.835	53.734	1.351	33.724
1102	116.030	120.523	26.624	5.136	123.377	55.306	1.503	33.557
1107	117.051	135.181	26.618	5.109	123.607	55.677	1.510	33.478
1104	122.089	206.386	26.588	5.057	125.308	57.432	1.546	33.415
1108	122.094	206.453	26.588	5.051	125.107	57.434	1.546	33.311

TABLE 2. Specific heat at constant volume, C_v , of methane; heat correction for calorimeter expansion Cl, heat capacity of empty calorimeter, C_0 , total heat capacity of calorimeter (full) $\Delta Q/\Delta T$ or DQ/DT , with temperature, pressure, density, and temperature increment, DT —Continued

ID	Temp K	Press bar	Den mol/l	DT K	DQ/DT J/K	C_0 J/K	Cl J/mol·K	C_v J/mol·K
1109	127.100	275.451	26.559	4.981	126.527	59.056	1.574	33.180
1105	127.123	275.769	26.558	5.028	126.592	59.064	1.574	33.210
1004	102.424	48.414	27.388	5.069	121.472	49.858	1.475	34.428
1001	105.029	90.948	27.371	5.078	122.552	50.974	1.619	34.267
1005	107.466	129.912	27.355	5.035	123.275	51.986	1.613	34.129
1002	110.058	170.735	27.338	4.981	124.205	53.030	1.637	34.049
1006	112.446	207.806	27.322	4.941	125.126	53.962	1.646	34.035
1003	115.142	249.013	27.305	4.914	126.082	54.979	1.652	33.999
1007	117.361	282.491	27.290	4.903	126.695	55.789	1.673	33.879
1912	92.592	40.274	28.164	3.061	120.491	45.311	1.351	35.326
1901	92.609	40.540	28.164	2.871	120.603	45.319	1.313	35.415
1907	93.793	62.384	28.155	2.873	121.008	45.899	1.458	35.186
1902	95.465	92.859	28.143	2.842	122.072	46.701	1.769	35.003
1913	95.634	95.885	28.141	3.022	122.178	46.780	1.765	35.020
1908	96.675	114.525	28.134	2.824	122.424	47.269	1.769	34.898
1903	98.301	143.313	28.122	2.807	123.144	48.020	1.740	34.913
1909	99.505	164.435	28.114	2.821	123.531	48.566	1.745	34.830
1904	101.123	192.506	28.102	2.793	124.316	49.288	1.768	34.839
1910	102.319	213.085	28.093	2.791	124.573	49.812	1.767	34.710
1905	103.902	240.032	28.082	2.749	125.401	50.495	1.755	34.793
1911	105.104	260.314	28.074	2.766	125.538	51.005	1.766	34.600
1906	106.655	286.252	28.063	2.751	126.307	51.653	1.781	34.644

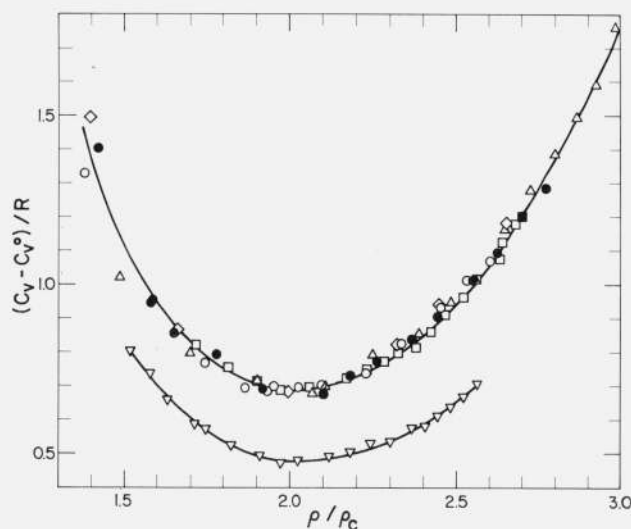

FIGURE 6. Reduced specific heats versus reduced density for CH_4 (●), F_2 (◇), O_2 (Δ), Kr (□), Ar (○), and Ne (▽).

Comparison of C_v methane extrapolated to saturation to several other liquids: F_2 [8], O_2 [6], Kr [13], Ar [14], and Ne [15] is shown in figure 6. The density is reduced by the critical density. The spectroscopic heat capacity, C_v^0 is subtracted in each case. Molar specific heats are independent of reducing parameters [16]. All of the data except that for Ne correlate quite well. Presumably this departure of Ne is a result of its being more of a quantum fluid. H_2 and He also depart markedly from this grouping as shown by Diller [16].

I would like to acknowledge the support of the American Gas Association. R. D. Goodwin's data of the PVT of methane were essential and his computer programs calculating the various functions and derivatives were of great help. I thank D. E. Diller for his numerous contributions. The data shown in figure 6 are from his work.

5. References

- [1] The S. I. (international system) unit of pressure is the Pascal (1 Pa = 1 N/m²). The bar is 10⁵ Pa, also 1 atm = 1.01325 × 10⁵ Pa, 1 lb/in² = 6894.757 Pa, 1 dyne/cm² = 10⁻¹ Pa. Also one mole methane = 16.0430 g, based on the ¹²C scale and the natural isotopic abundance averages: see Remy, H., Chem. Berichte **101**, 1 (1968).
- [2] Goodwin, R. D., J. Res. Nat. Bur. Stand. (U.S.) **65C**, (Eng. and Instr.), No. 4, 231-243 (Oct.-Dec. 1961).
- [3] Younglove, B. A. and Diller, D. E., Cryogenics **2**, 1 (1962).
- [4] Younglove, B. A. and Diller, D. E., Cryogenics **6**, 1 (1962).
- [5] Goodwin, R. D. and Weber, L. A., J. Res. Nat. Bur. Stand. (U.S.), **73A**, (Phys. and Chem.), No. 1, 1-13 (Jan.-Feb. 1969).
- [6] Goodwin, R. D. and Weber, L. A., J. Res. Nat. Bur. Stand. (U.S.), **73A**, (Phys. and Chem.), No. 1, 15-24 (Jan.-Feb. 1969).
- [7] Goodwin, R. D. and Prydz, R., J. Res. Nat. Bur. Stand. (U.S.), **74A**, (Phys. and Chem.), No. 4, 499-505 (July-Aug. 1970).
- [8] Prydz, R. and Goodwin, R. D., J. Res. Nat. Bur. Stand. (U.S.), **74A**, (Phys. and Chem.), No. 5, 661-665 (Sept.-Oct. 1970).
- [9] Walker, P. A., Dissertation (University of London, 1956).
- [10] Goodwin, R. D. and Prydz, R., J. Res. Nat. Bur. Stand. (U.S.), **76A**, (Phys. and Chem.), No. 2, 81-101 (Mar.-Apr. 1972).
- [11] Hoge, H. J., J. Res. Nat. Bur. Stand. (U.S.), **36**, 111 (1946).
- [12] Weibe, R. and Breevort, M. J., J. Am. Chem. Soc. **52**, 622 (1930).
- [13] Gladun, C. and Menzel, F., Cryogenics **10**, 210 (1970).
- [14] Gladun, C., Cryogenics **11**, 205 (1971).
- [15] Gladun, C., Cryogenics **7**, 78 (1967).
- [16] Diller, D. E., Cryogenics **11**, 166 (1971).
- [17] Jones, M. L., Jr., Mage, D. T., Faulkner, R. C., Jr., and Katz, D. L., Chem. Eng. Progress Symposium Series **59**, 52 (1960).

(Paper 78A3-820)