

THE SYNTACTIC FORMS

OF PREDICATION

by

Susan Deborah Rothstein

B.A. (Hons) University of Oxford

(1979)

Submitted to the Department of
Linguistics and Philosophy
in Partial Fulfillment of the
Requirements of the
Degree of

DOCTOR OF PHILOSOPHY

at the

MASSACHUSETTS INSTITUTE OF TECHNOLOGY

September 1983

© Susan Deborah Rothstein 1983

Signature of Author _____

Department of Linguistics and Philosophy
July 20, 1983

Certified by _____

Thesis Supervisor

Accepted by _____

Department Chairman

Archives
MASSACHUSETTS INSTITUTE
OF TECHNOLOGY

JAN 14 '84

LIBRARIES

THE SYNTACTIC FORMS

OF PREDICATION

by

SUSAN DEBORAH ROTHSTEIN

Submitted to the Department of Linguistics and Philosophy
on July 20, 1983 in partial fulfillment of the
requirements for the Degree of Doctor of Philosophy in
Linguistics

ABSTRACT

In this dissertation I propose a rule of predicate-linking, which accounts for the distribution of non-argument maximal projections. These XPs are considered predicates, and are treated as one-place syntactic functions, requiring completion, or saturation. This saturation is achieved by linking each predicative XP to an argument XP, its syntactic subject. "Subject" is always defined relative to a particular XP, and not as "subject of an S". The predicate-linking rule, which is a condition on well-formedness at S-structure, defines the syntactic conditions under which such linking takes place. There are two major advantages of representing S-structure in terms of syntactically defined subjects and predicates. In the first place, it allows us to account for constraints on phrase-structure not subsumed under X-bar theory. In particular, the phrase-structure rule $S \rightarrow NP\ INFL\ VP$ becomes redundant, and the occurrence of both small clause and main clause predicates is accounted for by the same principle. The predicate-linking rule should be seen as complementary to the theta-criterion; the latter is a constraint on the distribution of argument XPs, whilst the former is a constraint on the distribution of non-argument, or predicative XPs. In the second place, this representation makes available a simple algorithm which maps from S-structure, via LF, to the semantic component, using syntactic information to build a semantic representation in which semantic subject-predicate relations are encoded. Chapters III and IV of this dissertation discuss how it is ensured that a semantically appropriate argument is the subject of a particular XP. We see that there are general lexical principles which dictate that certain thematic arguments will always be interpreted as the subject of the maximal projections of the lexical heads which select them. We also see how the interaction between the lexicon and the syntactic and semantic components accounts for the asymmetries between subjects and objects. Chapter IV argues that the movement of arguments (i.e. cases where the trace left by Move- α is A-bound) and the insertion of pleonastics are syntactic mechanisms which have the effect of providing subjects for predicates which are not assigned one by lexical principles. Chapter V distinguishes between two forms

of syntactic predicates: primary, or clausal predicates, and secondary predicates, or small clauses. Chapter VI analyzes the structural properties of NPs and S's, and suggests why, unlike the other maximal projections, these XPs which may be predicative, may also be, and in most cases are, theta-marked arguments.

Thesis Supervisor: Dr. James Higginbotham

Title : Associate Professor of Linguistics and Philosophy

"אם ה' לא יבנה בית, שוא עמלו בוניו בו...."

"If the Lord will not build a house, his builders
work on it in vain..." (Psalms 127.1)

To my parents

Vivien and Michael
Rothstein

with love and many thanks

ACKNOWLEDGEMENTS

I should like to thank my advisor, Professor James Higginbotham, for all his help and advice during the preparation of this dissertation. I should also like to thank the other members of my committee who were generous in their time and criticism. I am indebted to Maggie Carracino, both for typing two drafts of the manuscript, and also for much, less tangible help. Diana Archangeli, Kyle Johnson, Margaret Magnus, Malka Rappaport and Lisa Travis all took care of the proofreading. Many people discussed various ideas and problems in the thesis with me, and I am grateful to them all for their time and interest. I thank my friends, who put up with me while all this was going on, and who kept me provided with food, drink, common sense and music. Finally, I thank my family: my brothers, Shimon and Joseph, and my parents, Michael and Vivien Rothstein, who were constantly encouraging from a long way away.

TABLE OF CONTENTS

	Page
I. Introductory Chapter	
1.1 Historical context	9
1.2 Theoretical context	15
1.3 Outline of the dissertation	15
Footnotes to Chapter I	18
II. The Definition of "Predicate"	
2.0 Introduction	19
2.1 Predicates as functions	21
2.2 The rule of predicate-linking	26
2.3 Some immediate questions	30
2.4 The paradigm cases of linking	32
Footnotes to Chapter II	44
III. "Syntactic Subjects" and "Semantic Subjects"	
3.0 Introduction	45
3.1 Deriving a semantic representation	45
3.2 Thematic relations	
3.2.1 The role of the lexicon	54
3.2.2 The syntactic representation of theta-marking	55
3.3 Lexically determined subjects	62
3.4 Subject and object asymmetries	74
Footnotes to Chapter III	87
IV. Syntactic Processes Which Result in the Satisfaction of the Predicate-Linking Rule	
4.0 Introduction	89
4.1 Move- α	
4.1.1 Move- α and move-NP	90
4.1.2 When the rule is required	91
4.2 Pleonastics	
4.2.1 Argument-less heads	95
4.2.2 Impersonal passives	100
4.3 Cosuperscripting	
4.3.1 Pro-drop languages	104
4.3.2 The connection between pleonastic insertion in English and Italian	109

4.4	The role of case	
4.4.1	Burzio's generalization	113
4.4.2	Quirky-case in Russian and Icelandic	118
4.4.3	Case assignment in Basque	124
4.5	The Extended Projection Principle	129
4.6	Raising-to-subject	
4.6.1	The problem with <u>seem</u>	133
4.6.2	The simple copula BE	136
4.6.3	Raising verbs as copulas	140
	Footnotes to Chapter IV	144
V.	Primary and Secondary Predication	
5.0	The two forms of predication	147
5.1	Secondary predication	
5.1.1	Syntactic properties of secondary predicates	147
5.1.2	Semantic conditions on secondary predicates	150
5.2	Primary predication	155
5.3	Formulating the definitions	160
5.4	Consequences of the definitions	167
5.5	Revising the theta-criterion	169
	Footnotes to Chapter V	173
VI.	The Structure of Arguments	
6.0	Introduction	176
6.1	NPs	
6.1.1	NPs as restricted quantifiers	178
6.1.2	Predicative and argument NPs	182
6.1.3	APs	187
6.2	S's	
6.2.0	The structure of S's	189
6.2.1	<u>Wh-</u> in COMP	190
6.2.2	COMP and tense	191
6.2.3	INFL and quantification over events	195
6.3	PPs as predicates	196
	Footnotes to Chapter VI	200
	Bibliography	202

CHAPTER I

1.1 A fundamental question which has exercised linguists especially over the last 25 or so years is how we know when a string of words constitutes a syntactically well-formed sentence of a particular language. An attempt at developing a grammar of a language, L, is an attempt to describe rules which will separate the syntactically well-formed sequences from the ill-formed ones. Chomsky (1957) develops a model for a transformational grammar. This proposes that the syntactic rules of a grammar are basically of two types, the phrase structure rules and the transformational rules. Phrase structure rules are rewrite rules which can be understood as recursive definitions defining a set of syntactically well-formed strings for a language. The basic symbol to be defined is S, (or sentence) which is rewritten

(1) S \rightarrow NP INFL VP

and then NP and VP are themselves defined, for example

(2) VP \rightarrow V (NP) (NP) (PP)*

where VP is rewritten as a verb followed optionally by no more than two NPs and an indefinite number of PPs. V is a terminal symbol, and thus cannot be rewritten, except as a lexical item of the category V, e.g., hit, run, etc. Non-terminal categories are rewritten

until there are no non-terminal constituents remaining. The transformational rules allow specific permutations of the output of the phrase structure component, relating by transformations pairs of sentences like

- (3) a. John fed the baby.
 b. The baby was fed by John.

The principle of transformations was the first major simplification of the phrase structure component. Because some structures can be formed by permuting the base structures, the work of the phrase structure grammar was simplified; a whole set of structures need not be generated by the rules. The advantage of this is twofold. In the first place there are many different syntactically well-formed sequences of English and it is a major empirical task to develop a rewrite system which generates all of them. The effect of transformations is to allow the system to generate only a basic set and to allow rules of permutation to generate the other structures. In the second place, the phrase structure grammar is basically descriptive. It describes by recursive definition which structures are well-formed but it gives no explanations of why this is so. Transformational rules are an attempt to make certain generalizations as to the types of syntactic permutations which are available, and as such make a step towards explanation.

The movement towards the simplification of the phrase structure component is one which has continued. However, transformational rules

did not have the desired results. It was seen that the generalizations made by transformational rules were also basically descriptive, and did not have explanatory force. Furthermore, in order for the rules to work, they had to be so complex, and to have such power that it was not possible even to make insightful generalizations as to what rules were possible rules of a language. The next step was a change of focus, in an attempt to deal with this problem. Transformational rules were simplified eventually to a single rule, move-category, or move- α . The phrase structure component (much simplified also) and the transformational component were no longer required to generate all and only well-formed strings of a language. Instead they may over-generate, and a modular system of constraints rules out the unacceptable sequences. These constraints include principles of case-assignment, locality conditions on movement, conditions on distribution of argument NPs, etc.

The goals of generative grammarians thus include the following: (1) to develop a grammar which will describe (i.e., generate) the well-formed sentences of a language and (2) in the process to simplify and develop the existing model of the grammar so that it does not merely describe, but also explains why all and only the well-formed syntactic strings are well-formed. It is hoped that the general explanations developed under (2) will not be language specific, but that we can identify various universal properties of natural languages which will also constitute part of an explanation of the cross-linguistic processes of child language-acquisition. These general principles will form part of a Universal Grammar (UG). It is hypothesized that as well as identifying general principles, we will also

be able to identify various parameters at which languages must make a choice between two options, for example, Rule R applies/does not apply in this language. Thus by isolating a limited number of parameters at each of which an independent choice must be made, we will be able to account for the differences between languages and explain how a few general principles such as the generalized transformation move- α can apply in a wide variety of languages, but with such different effects. The general principle which we will be discussing in this dissertation is that predicates must have subjects, and we will discuss various parameters at which languages make different choices, resulting in different rules for the realization of subjects in each language.

Work on the simplification of the phrase structure component took a great leap forward in 1977 with the publication of "A Theory of X-bar Syntax" by Ray Jackendoff. The basic principle of X-bar syntax is that rewrite rules need not be category-specific (for example (2) refers only to VPs) but can be stated in category-neutral terms. Rewrite rules are to be stated in terms of XPs, e.g.,

- (4) a. $XP \rightarrow \dots X' \dots$
 b. $X' \rightarrow \dots X \dots$

VP, NP, AP and PP, all have basically the structure defined in (4a). They are each projections of a constituent of the same category. The lower-level constituent itself is always a projection of a

lexical head of the same category. VP (or V'') is thus a projection of V' and V' a projection of V. A maximal projection is defined in the theory as the constituent which appears only on the left, and never on the right of the arrow in the set of rewrite rules in (4). Stowell (1981) attempts to refine Jackendoff's system even further, by suggesting that properties of phrase-structure rules can be predicted from other principles of the grammar, notably rules governing case-assignment.

X-bar theory is concerned with the internal structure of maximal projections. The problem which I discuss in this dissertation concerns not the internal structure of these constituents, but how they may be concatenated in a sequence of a language. This involves a discussion of the one remaining phrase structure rule which is not immediately brought under X-bar theory; and that is rule (1) which states that clauses must consist of a subject and verbal predicate.

Maximal projections can be divided into two types, argument XPs and non-argument XPs. The distribution of argument XPs is governed by a rule proposed in Chomsky (1981). This states that all argument XPs must be arguments of (=assigned a theta-role by) some lexical item and it is set out in the theta-criterion, clause (2). The claim of this dissertation is that there is a complementary rule which governs the distribution of non-argument XPs. These XPs are to be understood as syntactic predicates, i.e., open functions, and their distribution is governed by a rule stating that every syntactic predicate must be closed by being linked to an appropriate

syntactic argument, to be called its formal subject. This rule is called the predicate-linking rule and it is a condition of well-formedness on syntactic strings.

The advantages of this rule are several. In the first place, it accounts for the distribution of predicative XPs, which is its primary purpose. In this analysis both clausal and secondary predicates are accounted for by the same rule. In (5)

- (5) a. Mary saw John
 b. Mary ate carrots raw.

both the clausal predicate saw John and the non-clausal raw are linked to subjects. "Subject" is defined as subject of a predicate, and the effects of the phrase structure rule (1) are subsumed as a special case of predicate-linking. (1) states that clauses have subjects; the predicate-linking rule states that inflected (or main clause) predicates have subjects, along with all other predicates. An S is redefined as a particular type of (clausal) predication relation.¹ A second advantage of representing the syntactic string in terms of syntactic predicates and subjects is that it makes a mapping from the syntactic to the semantic representation very straightforward. Subject-predicate relations are among the relations to be represented in the semantic interpretation of a syntactic string. While a representation of syntactic (or formal) subjects and predicates is not isomorphic to the semantic representation, the algorithm mapping between them is simple.

1.2 The model of the grammar in which I am working is basically that of Chomsky (1981, 1982). It is set out diagrammatically in (6):

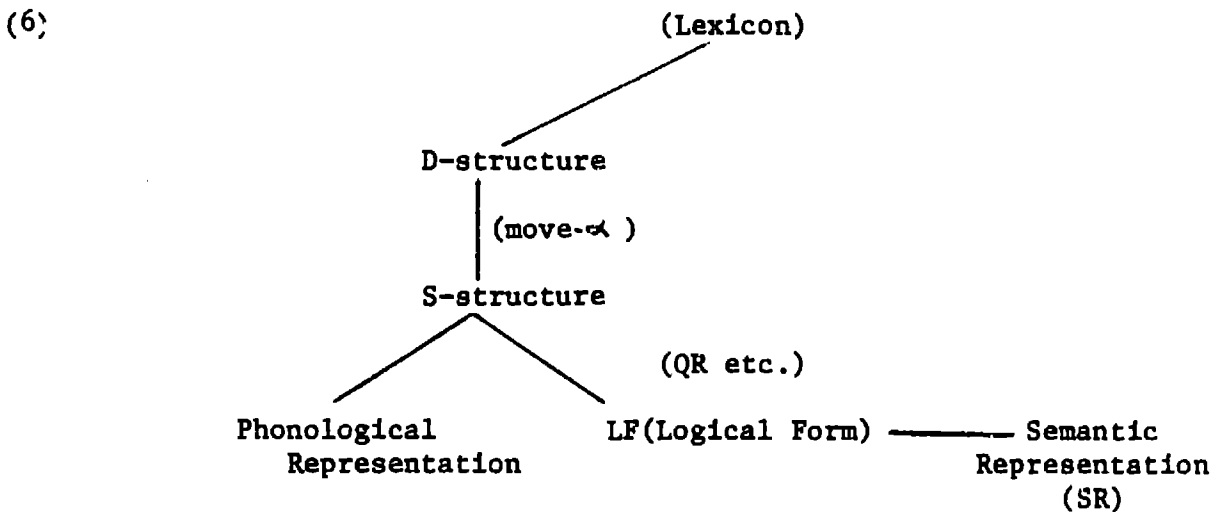

D-structure is the level at which underlying grammatical relations are represented. S-structure is the level at which surface grammatical relations are represented, but with D-structure relations encoded by means of traces. Move- α , the single transformational rule, maps between the two levels. S-structure is the input to the Phonological Representation and to LF, a syntactic representation at which quantifiers are assigned scope, and certain syntactic ambiguities are disambiguated. It is also the level at which thematic relations are checked. LF is the input to the semantic representation (SR).

1.3 The structure of this dissertation is as follows. In Chapter II I shall define the syntactic relation of predication, and the terms predicate and subject, and I will formulate the rule of predicate-

linking, a condition on well-formedness at S-structure, and show how this accounts for the core of well-formed syntactic configurations. In Chapter III, I discuss the relation between the syntactic and semantic notions of predication and propose an algorithm for a partial mapping between LF and SR. I then discuss the simplest method of satisfying the predicate-linking rule. When the head selects a thematic argument which, because of its semantic nature, is automatically "external," i.e. syntactically realized outside the maximal projection of the head, this argument will be the syntactic subject of that maximal projection. The predicate will then have its subject available at D-structure. Certain properties of such D-structure external arguments are discussed including the fact that there are semantic and syntactic asymmetries between external and internal arguments (subject and object). It is argued that all arguments are selected by a lexical head, and these asymmetries are due to S-structure and semantic rules of interpretation and not to asymmetries between the arguments within lexical representations. Chapter IV discusses what happens when a head does not have a lexically determined external argument, but has no arguments or only internal arguments. At D-structure the maximal projection of the head has no external argument to be linked to. In order that the S-structure be well-formed an external syntactic argument must be provided, and this occurs in one of two ways. In the first place, an argument of the head is moved by $\text{move-}\alpha$ to the external position. It is suggested that all cases of arguments being promoted to subject position are instances of $\text{move-}\alpha$ applying to ensure that an empty

subject position be filled, so that the predicate-linking rule may be satisfied. If this transformation does not take place, a pleonastic may be inserted at S-structure to satisfy the requirement that there be a formal subject. The conditions under which this may occur vary from language to language. Chapter V discusses the differences between clausal (or primary) predication and secondary predication and S is defined as an instance of primary predication. Chapter VI suggests an analysis of those constituents which may be arguments -- i.e., NP, S' and S, explaining why they do not require linking to a formal subject.

FOOTNOTES

- (1) Note that this is a different view from that developed by Stowell (1981, to appear) who argues that there are "subjects across categories". NP, AP, VP and PP as well as S immediately dominate subject positions. "Subject" is thus understood as the specifier of X". It is defined by the rule

(i) $X'' \rightarrow \text{SUBJ } X' \text{ Modifier}$

which is itself an instantiation of the generalized phrase structure rule

(ii) $X'' \rightarrow \text{SPECIFIER } X' \text{ Modifier}$

This differs crucially from our analysis in that for Stowell, the subject of a category is within the maximal projection of that category, whereas for us, the subject of an XP must be external to the XP. It also follows from our definition of the subject-predicate relation, and from the definition of S as an instance of clausal predication (the precise definition will be given in Chapter V) that S is not a projection of any category. This contrasts with e.g., Jackendoff (1979), Marantz (1980), who propose that S is the maximal projection of V.

CHAPTER II

In this chapter we will argue that a correct analysis of phrase structure configurations at S-structure is in terms of syntactically defined subjects and predicates. A predicate is an open one-place syntactic function requiring saturation, or closure by an argument. The syntactic unit which may be a predicate is a maximal projection (XP). All maximal projections are one-place functions which require closure, but an XP is a predicate only when it is closed by a syntactically external argument, i.e., an argument which is not c-commanded by the head of the XP. When an XP is closed by an external argument it is a predicate of or predicated of that argument. The argument is subject of the XP. APs, VPs and PPs must always be predicated of an argument. NP and S' may be predicated of an argument, but they may be closed internally without involving any mechanism external to the XP. The paradigm case of predication is the simple declarative sentence, where the VP is predicated of an NP, (called [NP, S], the first NP of the sentence) for example [[John]_{NP} [saw Mary]_{VP}] where the VP is predicated of the [NP, S] John.

NP and S', when they are internally closed have the status of arguments, and as such their distribution is restricted by the theta-criterion, which applies to all, and only to, arguments. A subject of a predicate must be an argument, but not all arguments are subjects -- for example Mary in the sentence just given. We will discuss in Chapter VI what it is about the structure of S' and NP which allows them to be internally closed, and thus to be arguments as well as predicates.

The internal structure of each type of maximal projection is restricted by the principles of X-bar theory interacting with the lexical properties of the individual lexical heads. The problem which we will consider here is that of defining where predicative XPs can occur. The distribution of XPs which are not predicative is governed by the principles of theta-theory (clause 2 of the theta-criterion), which state that arguments can appear only in theta-marked positions, and that only one argument can occur in each theta-marked position. Other principles indicate for configurational languages what structural positions these arguments can have. For example, it has been suggested (Stowell 1981) that in English case-assignment is only to adjacent NPs. The distribution of predicative NPs has to be accounted for separately. An XP which is a predicate of something by definition has to have an external argument to be a predicate of. A given configuration will be an acceptable S-structure for a sentence of a language L only if all the non-argument XPs have been properly saturated by external arguments. The question which must be answered is under what conditions can an XP which is allowed, or required to be predicated of something, be predicated of a given argument, and thus be interpreted as a saturated, closed, function. The conditions which are syntactically defined, will be set out in section 2.2. when we describe the rule of predicate-linking which acts as a syntactic condition on acceptability for S-structure -- analogous to the way in which the theta-criterion is a condition on acceptability at LF. This rule will account for not only the distribution of "main clause"

predicative XPs which combine with NPs to form Ss (instances of what we will call primary predication) but also for the distribution of the "small clause" XPs, or secondary predicates. It is an argument in favor of the predicate-linking rule, that it can account for the structural properties of both types of clauses in a single rule. Before we go on to discuss this, we will examine more closely the definition of predicate.

2.1 The relations "subject-of X" and "predicate of Y" are syntactic relations defined at S-structure. An XP which is predicated of an argument is termed a predicate, and an XP which has something predicated of it is the subject of that predicate and is termed a subject. Predicate and subject, too, then are syntactic terms, denoting syntactic constituents. If X is a predicate of Y then Y is the subject of X, and Y saturates the function denoted by the XP.

The term predicate is used from the semantic point of view as in Frege. According to Frege,¹ a grammatical predicate is a particular type of function expression denoting a function and it has certain properties common to all such expressions. A function, in the Fregean sense, is open, incomplete, or unsaturated; in order that it be closed, completed, or saturated the empty place must be filled by an argument. In a simple arithmetic function-expression, the empty place is marked by a variable and the argument which will complete the function is denoted by the name of a number. Thus in

(1) $3x^2$

the variable x marks the place where the name of a number will be inserted to complete the expression. Frege points out that the expression has two parts: the "sign of the argument", and the "expression of the function". The distinction is important because the two parts are dissimilar; the argument is "complete in itself" whereas the function is not, and requires saturation by an argument. In

(2) Berlin is a capital city.

the predicate is a capital city takes a name, in this case Berlin, to saturate it and make it a complete expression.

The syntactic predicate which we are concerned with is similar, but not identical, to Frege's grammatical predicate. Syntactic predicates too are incomplete expressions requiring the name of an argument to complete them. In a simple sentence

(3) John saw Mary.

the VP predicate saw Mary is an incomplete expression which requires an argument John to complete it. However, a syntactic predicate differs from "grammatical predicate" in that syntactic predicates are always monadic (i.e. one-place) functions, whereas for Frege, grammatical predicates may be polyadic. In

(4) Berlin is the capital of Germany.

the predicate is the capital of Germany is a one-place predicate while is the capital of is a two-place predicate requiring the name of a city and the name of a country for saturation. The counterpart of this type of predicate in the government-binding framework is the lexical head, which take arguments; the number and nature of which are specified by theta-roles, or thematic roles assigned by the head. For example, the verbal head see assigns an agent and a patient theta-role, and can be considered as a two-place function requiring saturation by two arguments of the appropriate thematic type. Thus whenever see is used, as in (3) above, it is a necessary condition for its acceptability that see is saturated by an agent and patient argument. Within the government-binding theory, the representation of a sentence in terms of heads and arguments is part of its LF representation, and the condition that all lexical heads must be saturated by the appropriate thematic arguments is part of the theta-criterion, a condition on LF. Knowing the number and type of theta-roles that a head assigns is a matter of lexical knowledge. The thematic properties of lexical heads are idiosyncratic, and have to be learned as part of the process of learning "how to use the word". Lexical heads are thought of as entered in a mental lexicon, and with each entry is the particular information one needs in order to use the word. Thus a (partial) lexical entry for give might look like this:

(5) give_{V(dative)}: agent patient goal

indicating that the verbal head give assigns three theta-roles and thus requires three arguments, that of agent, patient and goal. The information that it is a dative verb tells us that these arguments may be represented in one of two ways: either with a direct object and a prepositional object as in John gave the book to Mary, or with two NPs marked with objective case, as in John gave Mary the book.

In contrast to this, the structure of the syntactic predicate is determined only by the rules of syntax and has no connection with any semantic or idiosyncratic properties of the head. A maximal projection is a one-place function whose structural properties are determined by purely formal rules of syntax. However, it requires saturation by an argument in exactly the same way as grammatical predicates -- or lexical heads -- do. We have said that the theta-criterion is a condition on LF which says, in part, that all lexical functions must be saturated. The constraint on predicate-linking is an analogous condition on S-structure saying that all syntactic functions must be saturated. VP, AP, and PP require saturation by an external syntactic argument, which they are predicated of, and NP and S'², while they are allowed in some circumstances to be predicated of subjects, need not be saturated in this way. They can be closed internally, without involving anything external to the maximal projection itself, in which case, as we said above, they are arguments.

Examples of each of the four lexical categories (NP, AP, PP and VP) acting as predicates are given in (6).

- (6) a. John [gave Mary the book]_{VP}
 b. Bill [eats carrots [raw]_{AP}]_{VP}
 c. He [drinks tea [with sugar]_{PP}]_{VP}
 d. She [thinks him [a fool]_{NP}]_{VP}

In each of these examples in (6) the maximal VP is a syntactic predicate of the [NP, S]. In addition, in (b)-(d) the VP contains maximal projections of each of the other lexical categories, the AP raw, the PP with sugar, and the NP a fool, each of which are themselves predicated of an NP also within the VP. It is important to notice that the XP and its subject may, but do not always, form a constituent. The VP and its NP subject always form a constituent, and we will argue below that the NP predicate and its subject in (6d) also form a constituent. These are the instances of what we called primary predication. The AP and PP predicates in (6b) and (6c), though they must have structural subjects, do not form constituents with these subjects. These predicates are termed secondary predicates or "small clauses", and the relation between them and their subjects we will call secondary predication. The subjects of the secondary predicates in these examples are arguments of the verbs which govern them. This will turn out to be a defining characteristic of secondary predication -- the subject of a secondary predicate must be assigned a theta-role by another lexical head. Thus carrots is the patient argument of eats and tea the patient argument of drinks. By contrast, him is not an argument of thinks, rather the whole constituent him a fool is the argument of the

verb in (6d). This sketch of an analysis of secondary predication will be developed in Chapter V.

We can represent, formally, the predicate structure of XPs using Quine's notation (introduced in Elementary Logic and Methods of Logic, eds. 1-3). He uses a circled numeral or ① to indicate the places in a predicate expression where a free variable, or name, must be inserted to form a sentence from the predicate expression. Bearing in mind that -- as the examples of secondary predication show -- not all completed predicate expressions are sentential, we can nonetheless represent maximal projections as predicate-schemata with circled numerals indicating the argument position. Thus the examples of predicate XPs in (6) will be represented as

- (7) a. ① give Mary the book
 b. ① raw
 c. ① with sugar
 d. ① a fool.

Because the structure of all syntactic predicates is determined by the same formal rules, no syntactic predicate will have more than one empty argument position to be filled.

2.2 The rule of predicate-linking

The syntactic rule of predication, or predicate-linking³ defines the conditions under which an XP may be predicated of a given argument. It is stated in (8):

- (8) Rule of Predicate-linking (for English)
- a. Every non-theta-marked XP must be linked at S-structure to an argument which it immediately c-commands and which immediately c-commands it.
 - b. Linking is from right to left (i.e., a subject precedes its predicate).

We can therefore define the relationship X is a predicate of Y, or X is predicated of Y, in the following way:

- (9) X is predicated of Y (is a predicate of Y) if and only if X is linked to Y under (8).

and conversely:

- (10) X is the subject of Y if and only if Y is linked to X under (8).

(8) is divided into two clauses because each clause is of a different status in U.G. It is hypothesized that clause (a) may be universal, whereas (b) is language specific and may have no status in U.G., but instead it may follow independently from the language-specific properties. It is clear that there is a directionality constraint in English, but this may follow from other facts, such as its being a head-final language at the level of X" expansion. At the other extreme, in Walpiri there is evidence that (8a) holds, which we would expect if it is a principle of UG, but there is no directionality constraint. This is to be expected in a non-configurational

language, and will follow from whatever factors allow Walpiri its (virtually) free word-order.

The predication relationship is an assymmetric one. Configurations like (11), where two XPs are each linked to the other, are impossible.



"Regressive" linking as in (12) is also impossible:

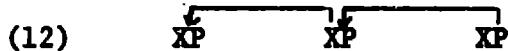

(11) is of course ruled out in English by the directionality clause (b), but a deeper claim is at stake; (11) and (12) are both ruled out by the properties of the predication relation. (8a) states that an XP must be linked to an argument, which is defined in the theory as a closed, i.e., non-predicative, XP. We can state the following principle, derived from (8a) and the definition of argument:

(13) If X is predicated of Y, then Y is not predicated of anything.

(11) and (12) both follow from this.

A further asymmetry between subject and object follows from the structural properties of XPs. As we showed above, an XP must take only one argument, which is to say it can be predicated of only one subject. A subject has no such structural restrictions, and may be the subject of more than one predicate, for example:

(14) John wrecked the car drunk

where John is the subject of wrecked the car and drunk. We shall see in Chapter V that there may be semantic restrictions on subjects taking multiple predicates, but if the structural constraint of mutual c-command is met then a subject may be subject of more than one predicate.

The status of the relation of predication in a theory of language acquisition is important. I shall argue in the next chapter that it is possible to interpret a subset of syntactically defined predicates of subjects as denoting expressions which are semantic predicates of those subjects. However, the syntactic relation is not defined in terms of semantic notions, nor is it taken to be a syntactic primitive. Rather, the relation predicate-of is definable syntactically, making crucial use of the concept of c-command. This is a concept which is central to various syntactic relations, including anaphoric relations and instances of coreference. Government, too, is a particular restricted form of the c-command relation -- c-command by a lexical head. Thus a child can grasp the relation of predication by applying the previously given configurational

concept of c-command to structures which are presented to him for interpretation.

2.3 The remainder of this chapter shows that (8) accounts for the basic predication relations in English. Before going on to this, we will mention briefly where the limits of (8) lie. As we have already remarked, NP and S', when they are in theta-marked positions, are not predicated of anything. As (8)-(12) indicate, it is necessary that some XPs are capable of being internally closed, and do not therefore require linking. If this were not the case, it would be impossible to avoid some form of the circularity of (11), where a predicate XP was itself linked to a predicate XP, violating (13). It is logically possible for a language to avoid this circularity by linking all XPs to pleonastics, but I know of no instances of this. The distribution of pleonastics is highly restricted, as we see in Chapter IV.

The condition that theta-marked XPs do not have to be linked has several interesting extensions. We have instances of a restricted class of PPs -- locative PPs -- appearing in what seems to be subject position, e.g. (16).

(15) In the armchair is a comfortable place to sit.

In English this construction is marginal, but Torrego (to appear) argues that the use of locative PP "subjects" in Spanish and Catalan, though restricted, is much more widespread than in English. In

English these PPs appear only with copulas and with raising verbs (which we shall argue later to be a special type of copula. Where a non-copula verb is used, the PP is understood as topicalized, e.g. (16):

(16) In the armchair sits my grandmother.

It is possible to analyze (15) as an instance of topicalization analagous to (16) or as Higginbotham (personal communication) suggests, (15) may be a reduced form of (17):

(17) [the place which is] in the armchair is a comfortable place to sit.

so that the constituent in [NP, S] position is in fact underlyingly a nominal. It remains to be seen whether the Spanish and Catalan cases can also be analyzed as analagous to (17).

Another extension of the condition that theta-marked XPs are not linked involves some APs. Prenominal APs such as blue, tall, old, as in the blue balloon, the tall man, the old house, are not linked to XPs at all. We shall argue in Chapter VI that this is because they are semantically and structurally part of the NP which immediately dominates them and so "share" in its theta-role. They therefore appear at S-structure as theta-marked and therefore are not subject to (8).

We shall also discuss in Chapter VI the structure of PPs which appear not to be linked to anything, for example:

- (18) a. It rained for three hours
 b. He buttered the bread with a carving knife
 c. She flew the spaceship to the Evening Star

An extension of (8) allows linking in certain circumstances to INFL, and in the examples in (18) the PPs are linked in this way.

2.4 The paradigm cases of linking are as follows:

- (19) a. NP ~ VP

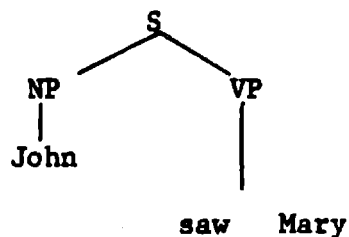

- b. NP ~ NP

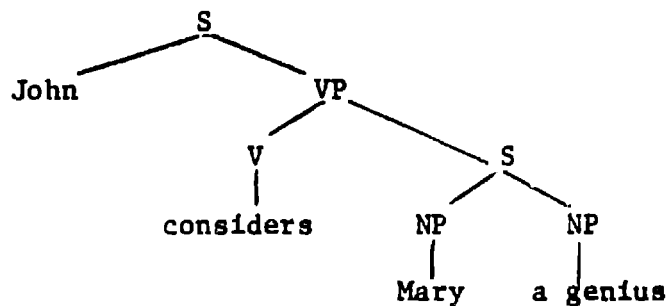

c. NP ~ AP

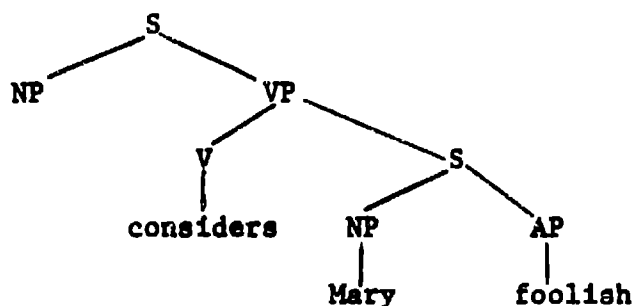

d. NP ~ PP

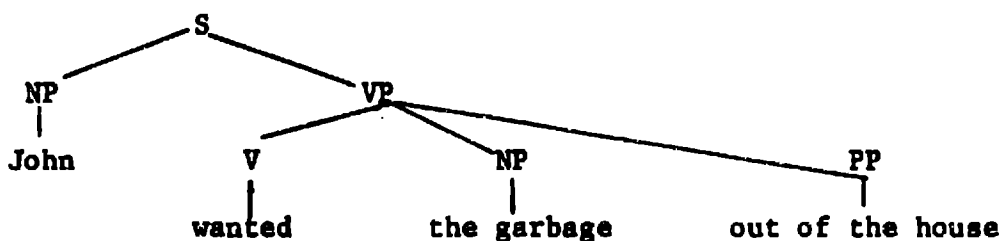

In each of these sentences, to begin with, the VP is linked to [NP, S] -- a structural term denoting the first NP in the sentence. (Note that in all these cases the NP which the predicate is linked to is interpreted as its "semantic" subject. How and why this is will be discussed in Chapter III.) NP and VP c-command each other; they are syntactic sisters. In examples (b-d) there are instances of the other categories linked by (8) to NP subjects and in each case NP and XP c-command each other. Early attempts (e.g., Reinhart 1976) to formulate the relation of c-command made reference to branching nodes and α was said to dominate β if and only if the first branching node dominating α also dominated β . Here we follow Aoun and Sportiche (1982) in assuming that the proper expression of the relation of c-command refers not to branching nodes

but to maximal projections; α c-commands β in the following circumstances:

(20) Definition of the c-command relation

α c-commands β if and only if every maximal projection dominating α also dominates β .

Mutual c-command, i.e. α c-commands β and β c-commands α means that α and β share all maximal projections, i.e. there is no maximal projection dominating α which does not also dominate β and there is no maximal projection dominating β which does not also dominate α . It is clear that the relation of mutual c-command holds between subjects and predicates in examples (19a-d). In fact, these subjects and predicates would c-command each other whether "c-command" was defined in terms of branching nodes or maximal projections. In each of the above examples the first branching node dominating each subject and predicate is a maximal projection. However, there are examples of predicate-linking where, according to the Aoun-Sportiche definition, subject and predicate c-command each other but where according to earlier definitions they would not do so. These examples show that the relevant configurational relation between subjects and predicates is that of being dominated by all the same maximal projections. Aoun and Sportiche have independent justification for arguing that the relation of c-command is to be defined as they suggest -- the theoretical reason is that maximal projection is already defined within the theory whereas branching-node as a theoretical term is needed nowhere in the syntax other

than in the definition of c-command. The examples cited here (21-22) are further support for the claim that the relation defined by Aoun and Sportiche is the relevant one.

The cases we are concerned with involve predicates which form a subset of the "small clauses." Here I am going to give certain arguments for a particular structural representation; a full discussion of this analysis of small clauses including its repercussions for the theta-criterion follows in Chapter V.

We have sentences like

- (21) a. John painted the car red
 b. Bill ate carrots raw
 c. Tom met Mary drunk

The suggested representations for (21a-b) are given in (22):

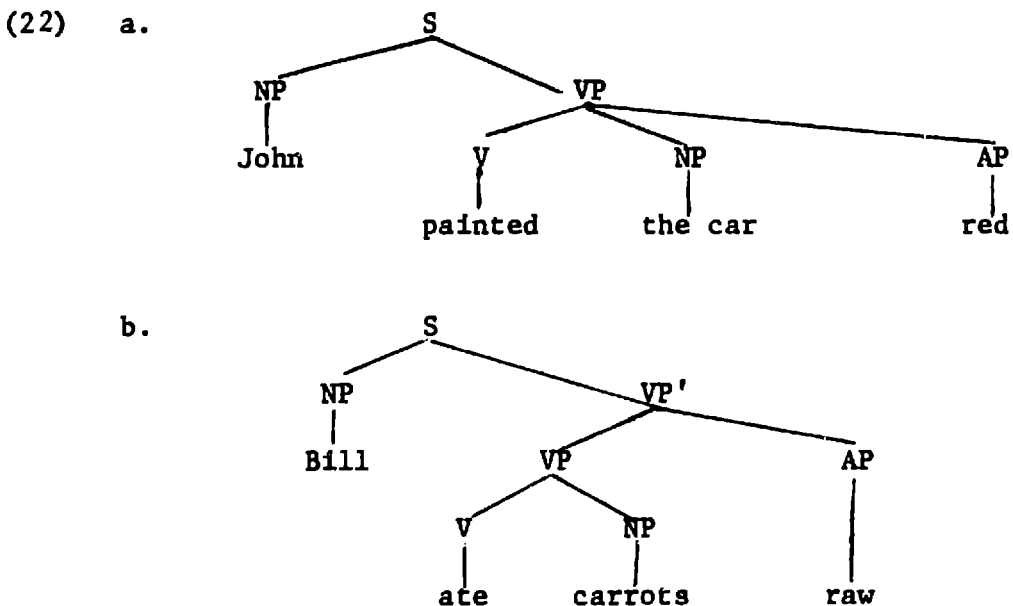

The two sentences are both examples of an AP predicated of an NP within the VP (i.e. what we have called secondary predicates) but they have different structural representations because they are of different semantic types. With each type is correlated certain properties and restrictions. I shall argue in Chapter V that restrictions on these predicates hold at all three levels of the grammar -- S-structure, LF and the semantic representation, with the restriction at S-structure being the rule of predicate-linking, -- but here it will suffice to state the reasons for representing the structures as in (22).

Much work has been done in distinguishing the various types of predicates (e.g. Halliday (1967), Levin and Simpson (1981), Simpson (1982)). The (a) example has been termed an instance of a resultative predicate; the predicate red is predicated of the direct object of the verb, here the house, and describes the result of the action described by the verb, the effect that this action has on what is denoted by the direct-object. In (21a) the action denoted by the verb is that of painting, and it has an effect on the thing denoted by the object NP; it turns it red. There is clearly a close connection between the verb and the predicate because of the meaning of the predicate; only when the verbal head of a VP denotes a change of state can a resultative predicate be predicated of the verb's direct object. It is the verb which dictates whether or not a resultative predicate is possible; we can see it as one of the verb's lexical properties that it allows for an optional resultative predicate.

This close relation between verb and predicate is expressed by representing (21a) as in (22a), with the resultative predicate hung from the VP as an immediate sister of V, and governed by it. Resultative predicates, like thematic arguments of a verb, are selected by the semantic nature of the verb and are represented at S-structure as immediate sisters of the verb. (Note, by the way, that it is not only the verbal heads which take predicates -- as we will discuss in Chapter V -- other lexical heads such as nominals have these properties. For example:

(23) The painting of the house red surprised us.

A further indication of the close relation between verb and resultative predicate comes from Icelandic, where resultative predicates occur with the same semantic restrictions as in English. In Icelandic a predicate of this type may be compounded with the verb.

(24) Eg hvít-~~þroði~~ fötín

I white washed the clothes

"I washed the clothes till they were white."

Only resultative predicates can be compounded in this way. Non-resultatives -- e.g. the Icelandic equivalents to (21b-c) -- can never appear in this form. The adjectival predicate appearing in the VP of (21b) has been termed a depictive predicate, and it describes the state of the thing denoted by the direct object of the verb (the [NP, VP]) at the time when the action denoted by the verb is

occurring. Thus raw in (21b) denotes a state which is predicated of the object denoted by the [NP, VP] -- i.e., the carrots, at the time when they are being eaten. A paraphrase of (2 b) might be

(25) Bill ate the carrots when they were raw.

This paraphrase is important because when the verb denotes not a single action but a habitual one, the depictive predicate can be interpreted as a conditional.

- (26) a. Bill eats carrots raw.
b. Bill eats carrots when they are raw.

The ambiguity of the paraphrase between "Bill eats carrots which are raw", and "Bill eats carrots only when they are raw" highlights this. The semantic properties of depictive predicates are complex -- they will be discussed in more detail in Chapter V. What it is important to note here is that there is no close connection between the verb and the depictive predicates which we saw to exist between verb and resultative predicate. In the case of depictives the semantic role of the predicate differs depending on the aspect of the verb -- as contrasts between (21a) and (26a) show. Contrasts like

- (27) a. John ate the meat raw/*tasty
b. John ate the meat salted/*salty

indicate that only certain types of states can be predicated of the object denoted by the [NP, VP] and that the restrictions do not seem to result from the semantic properties of the verb. This contrasts with the data on resultatives where a certain type of verb allows the possibility of a predicate interpreted as a resultative and the constraints on what the predicate can be are the constraints of the real world. The anomaly of

- (28) John painted the house scorched (where scorched is a resultative predicated of the house)

is due to the real-world fact that scorched is not a result of painting. Real-world facts don't account for the ungrammatical examples in (27) -- there is nothing in the world which makes it possible to eat meat when it is raw or salted but impossible when it is tasty or salty. The structural representation in (27a) is supposed to encode the close connection between verb and resultative predicates and the similarity between predicate and nominal arguments of the head, both of which are selected, obligatorily or optionally, by the verb. Conversely, the structural representation of (21b) given in (22b) encodes the fact that depictive predicates are not closely related to the head of the VP. That depictives are attached to the VP node in this way makes certain predictions about occurrences and co-occurrences of predicates. To start with, only one resultative can appear in a sentence

- (29) *John washed the clothes clean white

whereas more than one depictive can appear in a sentence:

(30) They eat meat raw, tender. (from Simpson 1982)

This we will assign a structure as in (31):

(31)

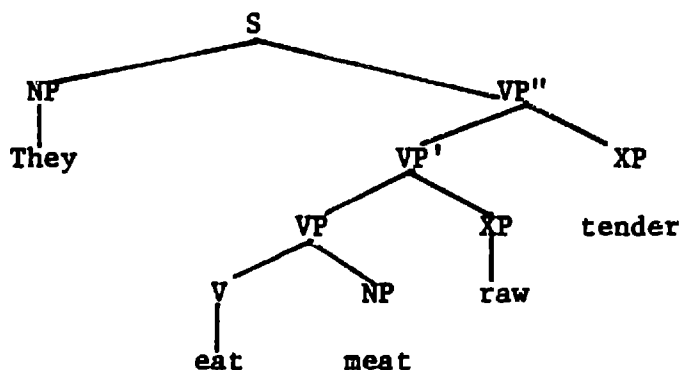

The 'double-stacking' captures the fact that each XP is a condition on the whole of the VP preceding it. An XP hung from VP is a condition on VP^{n-1} so that the paraphrase of (30) should be

(32) They eat meat when the meat is raw when the raw meat is tender.

Our analysis also predicts that when resultatives and depictives co-occur in a sentence the resultative must precede the depictive.

This is borne out:

- (33) a. We hammered the metal flat hot
 b. *We hammered the metal hot flat.

In presenting this analysis of predicates and in arguing that a predicate has to be linked to an NP which it c-commands and which c-commands it, we are making a particular claim about the nature of maximal projections -- namely that in (22b) and (31) it is not the VP but the VP' and the VP'' respectively which are the maximal projections of the V. This implies that a maximal projection of a category is defined relative to a particular tree; it is not possible to state out of context that V'' is a maximal projection of V. VP'' is the maximal projection of V in (31); VP' is the maximal projection of V in (22a), and VP is the maximal projection of V in (19). (21c), rewritten here as (34) is ambiguous:

(34) John met Mary drunk.

drunk can be linked to, and predicated of, either John or Mary. Depending on which interpretation is chosen a particular structure will be assigned:

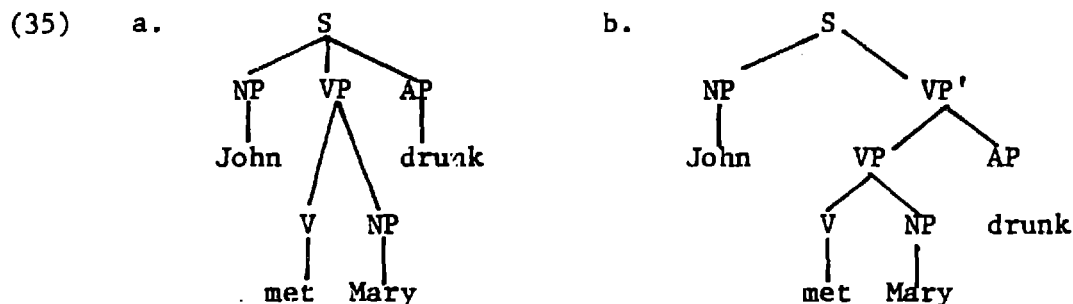

In (35a) drunk must be linked to John because that is the only NP available for linking to under the predicate-linking rule;

similarly in (35b) there is no subject for drunk other than Mary, so this is the linking which must take place. This makes predictions about the order in which multiple predicates may occur: the XP predicated of [NP, S] will always be the rightmost: in (36)

- (36) a. John eats meat raw drunk
 b. [John [eats meat raw]_{VP}, [drunk]_{AP}]_S.

the structure must be as in (36b) where raw is within the VP and drunk is a syntactic sister of the [NP, S] and the VP'. Note that the semantics, also, predict that drunk is not part of the VP. Whilst depictives which are part of the VP state 'conditions' on the rest of the VP, as argued in (26b), drunk does not function in this way. The paraphrase of (36a) should read

- (37) John eats meat when the meat is raw, when John is drunk.

If predicates predicated of [NP, S] are hung directly from the VP, this implies that predicates selected for by the verb cannot be predicated of the [NP, S]. Thus we predict that resultatives can never be predicated of [NP, S] and this is borne out

- (38) *John painted the carts tired. (i.e., until he was tired).

A possible problem for this analysis was suggested to me by Ken Safir. In

(39) Drunk, it's hard PRO to drive

the AP, drunk, has as its semantic subject the NP, PRO: this must be its structural subject too, and there is no other NP it can be linked to, though PRO does not c-command drunk. One suggestion is that drunk has its own PRO subject.

(40) PRO drunk, it's hard to drive.

There are several theoretical reasons for not allowing predicates to have their own PRO subjects which we will discuss in section 5.5. But here, it seems that there is an analysis of (40) which avoids these problems, which is that drunk is a topicalized AP moved from its underlying position to the right of the VP; thus the S-structure of (40) is actually

(41) [Drunk]_{AP₁} [it's hard [PRO [to drive]_{VP} [t]_{AP₁}]] .

Here the PRO and the trace of drunk c-command each other, and drunk and its trace are, of course, co-indexed by move- α . This implies that a straightforward emendation of rule (8a) is required.

(42) An X not in a (potential) theta-position, or a trace it is co-indexed with must be linked at S-structure to an argument which it c-commands and which c-commands it.

FOOTNOTES

- (1) Function and Concept: 1891.
- (2) S' is considered to be a projection of COMP. The relation between COMP and INFL is discussed in Chapter VI.
- (3) The rule is termed predicate-linking rather than simply predication, in order to distinguish terminologically between predication at the semantic level and at the syntactic level. An XP which is a predicate of a given argument is linked to that argument at S-structure. Some, but not all, syntactic predicates are predicated, at the semantic level, of the items they are linked to at S-structure.
- (4) In the general case (8) has to account for the fact that every non-theta-marked XP has to be linked to a syntactic argument. The only exception, of course, is that pleonastics, which are by definition non-theta-marked, are still not linked. However, in the strictest sense, an XP is a projection of some X, and therefore, a pleonastic, not being a projection of anything, but rather a formal "place-holder", is not subject to (8).

CHAPTER III

3.0 The predicate-linking rule introduced in the previous chapter expresses the fact that every predicate must have an external syntactic argument. The structural restrictions on syntactic arguments follow, as we have seen, from certain general conditions: a predicate can be linked only to something which does not itself require linking, i.e. to something which is internally closed. This means that linking is to NPs and S's and in some cases maybe to locative PPs also.¹ We now have to ask what other restrictions there may be. The answer lies in the interaction of syntactic rules with theta-theory, and it is to this topic that Chapters III and IV are devoted.

3.1 The topic involves a larger issue: that of the interaction of the syntactic and semantic components. The subject-predicate relations defined by the predicate-linking rule are strictly syntactic in nature, but there are also semantic notions of predication and of subjecthood. We presume that these semantic subject-predicate relations are represented in a level of semantic representation (SR), and that in the mapping from S-structure to SR the semantic component must use syntactic information to determine which are the subject and predicate in the semantic sense. (In order to distinguish between the different uses of the terms we will refer to the subject and predicate defined at S-structure as the formal

subject and predicate, i.e. the words used in the syntax. Subject and predicate in the semantic sense, i.e., the denotations of the words, we will call the notional subject and predicate.) As we indicated in Chapter I, an advantage of representing S-structure in terms of formal predicates and subjects is precisely this: that it makes available a simple mapping from the syntax to a semantic representation in which subject-predicate relations are made explicit. Before discussing what form this mapping is likely to have, we should look more closely at the semantic notion of predication.

We will consider subject and predicate, as represented in the semantic component, in the Aristotelian sense. Aristotle presents the terms subject and predicate in De Interpretatione², paragraphs 4 and 5 and goes on to make explicit use of these concepts in the Prior Analytics. He defines a predicate as an expression which is a sign of something said of something else, i.e., "something predicable of or present in some other thing" (paragraph 4) and goes on to use the three definitions as co-extensive. Something is predicable of something else if and only if it can be said of that thing and if and only if it is present in that thing. The "thing" which it is said of or predicated of is the subject. The only refinement required is that of allowing negative predicates such as "is not healthy" and "is not ill", which are the signs of "the absence of something in the subject." A subject and its predicate together form a proposition. A proposition is a type of sentence -- i.e., a "significant portion of speech, some parts of which have independent meaning," and which differs from other sentences because it has a truth-value; it must

be either true or false. A simple proposition is either a simple affirmation or a simple denial: it either asserts or denies that what is expressed by the predicate Y is present in the denotation of the subject-expression X. However, it is important to note that in Aristotelian terms, the concatenation of subject and predicate is not sufficient to constitute a proposition P. P must always contain a tense-marker, or as Aristotle puts it, "A verb or the tense of a verb." A proposition is "a statement, with meaning, as to the presence of something in a subject, or its absence, in the present, past, or future, according to the divisions of time."

What comes out of this is that basic semantic notions are that of proposition, predicate and subject. Sentences to which truth or falsity can be ascribed have a basic structure in which something is said about something else. Predicate describes the expression used to signify the "something said about" and subject describes the expression denoting the "something else." There is only one subject in a proposition, though of course it can be a complex subject, e.g., Socrates and Callias as in "Socrates and Callias are healthy." This definition of predicate is thus, essentially, semantic and contrasts with the Fregean grammatical predicate which denotes a polyadic function which takes n arguments to form a sentential expression.

Given this account of semantic primitives, subject and predicate relations must be fundamental in a semantic representation. In the model of grammar with which we are working, the syntax, and more precisely, the LF representation, provide the information out

of which the semantic component builds a semantic representation. Semantic subject-predicate relations must thus be encoded in the syntax. The S-structure representation given by the predicate-linking rule encodes such semantic information, and the mapping between S-structure and the SR via LF is straightforward. Semantic predicates are encoded in maximal projections which must be linked to syntactic arguments. Notional subjects are encoded in formal subjects, the syntactic arguments which the XPs are linked to and which saturate or complete them. Thus the simple sentence Birds fly will have an S-structure representation as in (1):

(1) [[Birds]_{NP} [fly]_{VP}]_S ..

The VP denotes the semantic predicate "fly" and the NP to which the VP is syntactically linked denotes the notional subject of this predicate, the species bird.

The simplest possible algorithm for mapping between syntax and semantics would be "An XP linked by the predicate-linking rule to an argument A, is interpreted by the semantic component as predicated of the denotation of A." However, this will give the right results only if the S-structure, in terms of syntactic subjects and predicates, is isomorphic to the semantic representation of notional subjects and predicates, and this is not the case. Although all notional predicates can be correlated with XPs and their respective notional subjects correlated with the arguments that the appropriate XP is linked to, the converse does not hold. Not all XPs linked to

syntactic arguments to satisfy the predicate-linking rule correlate with predicates and subjects in SR. To give a simple example, in

(2) It snows.

the VP snows is linked to a pleonastic at S-structure to satisfy the predicate-linking rule and is thus the formal subject of the VP. However it bears no semantic relation to snows and there is no subject-predicate structure in the SR of (2).

However, as we have already mentioned in the model of grammar we are working with, mapping from syntax to semantics is mediated by LF. If we want to use an algorithm like the one stated immediately above, it is LF and the SR which must be isomorphic in the relevant respects. It is the case, as I shall argue throughout this dissertation, that the simplest possible algorithm does give the right results and that LF and SR are indeed isomorphic in the relevant respects. Predicate-linking takes place at S-structure, and the proper linking of all XPs is a condition on well-formedness at S-structure. The mapping between S-structure and LF is also as simple as possible (i.e., the rules alter the structure as little as possible). Thus all syntactic subjects and predicates linked at S-structure will be so linked at LF unless the rules mapping onto LF from S-structure have "broken" the linkings. If LF and SR are to be isomorphic with respect to subject-predicate relations then the following must hold:

- (3) All predicate-linkings at S-structure which are not to be interpreted as semantic predications at SR must be "broken" by the mapping from S-structure to LF.

The algorithm which maps from LF to the semantic representation may now be stated very simply:

- (4) If X is the formal subject of Y at LF, then X is interpreted as the notional subject of Y at SR.

Given that it is analytic within the theory that if X is the subject of Y then Y is predicated of X it follows from (4) that if Y is predicated of X at LF then Y is interpreted as predicated (semantically) of X at SR.

A point to be clarified about the relation of predication at SR involves PPs such as to Mary in

- (5) John gave the book to Mary.

Here, according to the predicate-linking rule, the PP must be linked, and the NP it must be linked to is the book. (In Chapter VI we will discuss another option for the linking of PPs, that they can be linked to INFL.) If to Mary is linked to the book then according to (4) the PP is interpreted semantically as a predicate of the NP.

It might be suggested that this semantic predication relation differs from the predication in, e.g., John eats carrots raw, where carrots is both the formal and notional subject of raw, and raw

is understood as a property in some sense ascribed to carrots. It is difficult to understand to Mary as a simple property ascribed to the book. Rather the locative preposition to names a two-place semantic relation indicating location, in (5) the second place in the relation is filled by Mary, while the first place is filled by the formal subject of the PP. Semantically, what is being predicated of the NP subject is the change of location, being "to Mary."

We can distinguish between the two "varieties" of predicates straightforwardly. The AP raw assigns a theta-role to its formal subject while the PP does not do so. We can describe the relation between the PP predicate and NP subject in (5) in the following rule of interpretation:

- (6) If X is the formal subject of Y at LF, and the head of Y denotes an n-place relation, then at SR, X is interpreted as being the first argument in the relation denoted by the head of Y.

In the case of (2) above, it snows cannot have a subject-predicate structure in SR because pleonastics are non-theta-marked syntactic "dummies" which are ignored at LF. (2) has a semantically operative representation (7):

- (7) $[[\text{snows}]_{\text{VP}}]_{\text{S}}$

and as the VP is not syntactically linked at LF, it' cannot, according to (4) be interpreted as a semantic predicate. We will discuss the

question of pleonastics, as well as more complex instances of "link-breaking" in Chapter IV.

The predicate-linking rule, then, has as its output a syntactic representation which directly encodes the semantic primitives of subject and predicate. The other basic semantic notion which is introduced in the Aristotelian framework is that of proposition, which intuitively we can correlate with the syntactic "S". The syntactic definition expressed by the phrase structure rule (8)

(8) S \rightarrow NP INFL VP

reflects directly Aristotle's claim that a proposition consists of a subject, predicate and tense. (8) states that an S consists of a syntactic, verbal predicate, linked to a subject, with a syntactic tense marker. Later we will argue that (8) is not the best way to state the definition of S; for the moment it suffices to point out the following. A proposition can be defined in terms of a semantic (i.e., notional) subject and predicate and the syntactic correlate of a proposition, the S, can be defined in terms of the syntactic correlates, a formal subject and predicate. Although (8) is not the best way to define the S, it does capture the intuition -- which Aristotle also makes explicit -- that an S is more than just a subject and predicate; something else -- hypothesized to be tense -- must be present as well. The converse of this is also true. There

are instances of syntactic predication where the XP and its NP subject do not form an S; and where the notional subject and predicate denoted by the syntactic correlates do not form a simple proposition. These, of course, are the secondary predicates mentioned in 2.2, such as

(9) John ate the meat raw.

The distinction between primary and secondary predication and the relation between instances of predication and propositions will be discussed at greater length in Chapter V.

One further point must be made before we go on to discuss the interaction of the predicate-linking rule with theta-theory. We have argued in this section that there is a set of basic semantic notions which includes subject, predicate and proposition, and a set of formal syntactic concepts which correlate with them. The structure of an S reflects the structure of the proposition. However, this is not to make a claim that either syntactic or semantic notions are conceptually prior. There is no "directionality" implied in the model, and no presumption as to which level of representation is more fundamental in language acquisition. It is possible that the semantic concepts of subject and predicate -- "picking something out and saying something about it," -- may be conceptually prior and that the syntactic constraints reflect the semantic structure. However, it is equally plausible that the structural relation of predication is conceptually prior, and the semantic structure is

a reflection of this. As we have seen, it is clear that each can be defined independently of the other.

3.2 Given this account of the interaction of the syntax and semantics, the following questions arise. With respect to the syntax we must ask what, in each instance, is an appropriate argument for the XP to link itself to? We have seen that the argument must be closed -- i.e., either an S' or an NP -- and it is clear from empirical observation that in the overwhelming majority of cases the subject argument is an NP. In fact, if we follow Koster's 1979 account of S' subject sentences, then we can say simply that all subjects are NP. We will discuss the question of S' subjects later, and concentrate for the moment on NP subjects. The predicate-linking rule gives a structural criterion for an NP being an appropriate subject -- the relation of mutual c-command must hold between it and its predicate, but this is not all that must be said. To begin with, we noted that in some circumstances pleonastics may operate as subjects, but not in all cases. (Compare the acceptable (2) to the unacceptable "it drives the car" (where it is not the neuter correlate of he and she.)) An account must explain where pleonastics can occur and why. Secondly, and this involves the semantic representation too, the subject NP has to be thematically appropriate for the XP, whether to avoid simple cases of semantic anomaly like "John injured the rock" where injure takes an animate object, or cases like "the rock hit John" or "Sincerity admires John" where in each case the thematic roles have been permuted so that the NP we would expect to find in subject position has changed places with

the NP we expect to find in object position. The answers to questions of this type lie in theta-theory, and this is what we will examine in the rest of this chapter.

3.2.1 The principles of theta-theory can be stated very simply. The chief principle is that a lexical head is a function which may require certain arguments of particular semantic types in order to be completed. The lexical head is considered as assigning theta-roles or thematic roles, and the information as to the number and type of theta-roles that a given lexical head assigns is part of the information associated with it in the lexicon. For example, the information associated with the head give is that it assigns agent, patient and goal theta-roles, i.e., that the lexical head takes three NPs which will be interpreted as having agent, patient or goal relations to the action described by the verb. Theta-theory is thus responsible for conveying two types of information about a lexical head; firstly how many thematic arguments are required for the head to be completed and secondly what type of argument is required in each case for semantic compatibility. If the wrong number of thematic arguments are supplied the sentence is either elliptical as in (10), where there are argument positions which are

(10) John gave .

not filled, or plainly ungrammatical as in (11)

(11) *John gave Mary Bill the book.

where there is one argument which is uninterpretable because it has no theta-role and is thus not related thematically to any lexical head. When the lexical meaning of an argument is not compatible with the thematic role it receives, then the sentence is semantically anomalous, as for example in (12):

(12) #Sincerity admires John. (where # indicates semantic anomaly).

Here admires may be considered as assigning a theta-role "experiencer" or "+animate" to its first argument and sincerity is not an NP which is compatible with this role. Presumably semantic/thematic compatibility is checked by the semantic component, where information about lexical meaning is available. This explains why sentences like (12), or the famous "Colorless green ideas sleep furiously" are syntactically well-formed but semantically anomalous -- the sentences satisfy syntactic conditions on acceptability, but not conditions which operate at the level of semantic interpretation. Whether or not the correct number of arguments are present for the lexical function to be satisfied is a syntactic matter, as shown by the fact that (11) and (12) are at worst, uninterpretable and at best, in the case of (11) elliptical. The axiom of theta-theory which guarantees that sentences with these problems are marked as unacceptable by the grammar is the theta-criterion:

(13) Theta-criterion (Chomsky 1981)

- (i) Every obligatory theta-role must be assigned to one and only one argument,
- (ii) Every argument must be assigned one and only one theta-role.

We will have reason to modify (13) in Chapter V, following Schein (1982), as it appears that the second clause is too strong and should not contain a biconditional, but (13) is the axiom argued for in Chomsky (1981) and (1982). (13) holds at LF, where theta-role assignment is represented. If we look at the relation between a lexical head and its theta-marked arguments as the relation between a function and its arguments then (13) can be understood intuitively as the condition that every function must be completed and every argument must be an argument of some function. We will return to this at the end of Chapter IV.

In English the preferred method of satisfying the predicate-linking rule is by linking to a lexical NP, assigned a theta-role by the head of the XP. It is used only when the lexical head does not assign any theta-roles; as is the case with snow and rain.³ When the NP-subject is a lexical argument of the head, then there are two ways in which it can be "assigned" to that position. In the first case, it can be assigned to that position in D-structure, its D-structure position being decided by general principles governing how thematic relations are syntactically realized. It is a matter of lexical knowledge that a lexical head has certain theta-roles to assign

but in addition to this knowledge there must be some syntactic relation between the head and the NP encoding syntactically that one is an argument of the other. The three methods available for encoding this information are direct-case marking by the head, case-marking via a preposition and predicate-linking. In

(14) John gave the book to Mary,

the thematic relation between the book and the verbal head is encoded by direct case assignment, the relation between Mary and the head is through case-assignment via a preposition, and the relation between John and gave is indicated by the fact that John is the syntactic subject of the VP. There seem to be general principles governing how particular types of theta-roles are realized. In English, the NP bearing the agent role will always, in an active verb, be assigned to the syntactic external argument position, and be related to the head via predication. The NP bearing patient role will be realized in a position where it can be assigned objective case -- i.e., internal to the VP, and adjacent to the V. The syntactic relations dictated by the general principles of syntactically encoding theta-marking are represented at D-structure. When these general principles ensure that a lexical head has an argument in the NP-subject position so that the maximal projection of the head can be linked into it, then the predicate-linking rule is satisfied in the simplest possible way. The D-structure representation will then be identical (in the relevant respects) to the S-structure

representation, as is the case with (14). This is the first method of deciding which argument a lexical head is predicated of.

However, it may turn out that the general principles assign no thematic argument to the external syntactic argument position. This may be for one of two reasons. Firstly, the lexical head may just not have any thematic arguments of the appropriate type. For example, the so-called "unaccusative" verbs or "ergative" verbs (Burzio 1981, L. Levin 1983) are generally analyzed as taking only one argument, a "theme", which should be assigned to the [NP VP] position. These verbs include arrive and come, for example, and the D-structure of a sentence like John arrived is hypothesized to be

(15) [[arrived John]_{VP}]_S

with an unlinkable VP.

The second instance of a D-structure where there are unlinkable XPs occurs where the thematic argument assigned by general principles to the external syntactic argument position has been detached by a lexical rule. This happens in passive constructions where a lexical rule "delinks" the agent, giving a paradigm D-structure representation as in (16).

(16) [[was given the book to Mary]_{VP}]_S

Here again the VP cannot be linked because nothing is available for it to be linked to.

In these instances the grammar has methods of ensuring that there is a thematic NP available at S-structure for linking. In English, the mechanism is Move-NP. In both (15) and (16) the [NP VP] is moved outside the VP, so that the VP can be linked to it at S-structure -- and so that the theme can be interpreted in the SR as the notional subject. Another device which some languages use instead of the Move-NP mechanism is that of inserting a pleonastic element in the [NP, S] position, which operates as the formal subject and which is co-indexed (cosuperscripted) in Chomsky (1981)) with an internal argument. The formal linking at S-structure is thus to a pleonastic, but because the pleonastic is cosuperscripted with the internal argument, and represented as such at LF, the structurally internal argument can be interpreted as the notional subject. English permits this in a very restricted number of cases where there is inserted in the [NP, S] position. These can be cosuperscripted only with an indefinite NP, and then only with verbs of a particular semantic type:

- (17) there $\left\{ \begin{array}{l} \text{was} \\ \text{stood} \\ \text{appeared} \end{array} \right.$ a man in the garden

In French, there are similar restrictions on the type of NP that can be used in this construction, but the mechanism can be used in a wider variety of circumstances, e.g., with a passive verb.

- (18) il a été mangé trois gâteaux.

In Italian and Spanish the vocabulary of pleonastics includes the empty pronominal pro which appears in [NP, S] position and which is cosuperscripted with a postverbal NP, either one which is underlyingly [NP, VP] or one which has been adjoined to the VP through rightward move- α .⁴

Pleonastics which are not cosuperscripted with post verbal NPs occur only when the lexical head has no thematic arguments at all, so that there is nothing to cosuperscript with. The pleonastic must be inserted so that "degenerate" monadic VPs like snow can be linked to satisfy the predicate-linking rule, but these "free" pleonastics, unlike the cosuperscripted ones, are not represented at LF; the degenerate VPs are not interpretable as predicates of a subject in the semantic component, and presumably a sentence like (2) forms some sort of "degenerate proposition" in the semantic sense.⁵

In summary, general lexical principles will, in the simple case, indicate which NP is to be syntactically external to the maximal projection of the lexical head. When this external argument position is not filled this way, mechanisms such as move- α or cosuperscripting are employed to ensure that the predicate-linking rule can be satisfied. In the degenerate case where neither of these mechanisms will work, a pleonastic is inserted simply to satisfy the S-structure requirement, because no thematic NP is available to fill this position. In the remainder of this chapter we will take a closer look at the way theta-marking properties are

represented in the lexicon, and at how the syntactic encoding of theta-relations takes place. In Chapter IV we will examine the mapping from D-structure to S-structure -- that is, how move- and the cosuperscripting mechanisms work.

3.3 In this section we will look more closely at how theta-roles are assigned and at how the relations between a head and its thematic arguments are represented at S-structure. Lexical heads are presumed to be listed in a lexicon, together with pertinent grammatical information. Part of this information is how many thematic arguments a head takes -- i.e., how many theta-roles it assigns -- and what type of theta-roles these are; agent, patient, goal, etc. These thematic arguments are realized as syntactic arguments of X° at S-structure. As far as the syntactic realizations are concerned, an argument of a head is either external or internal. An external argument is outside the maximal projection of the head, and thus is not c-commanded by it. An internal argument is within the maximal projection of the head and is c-commanded by it.

There are various ways in which an NP argument can be syntactically encoded in English. An internal argument can be in the [NP, VP] position -- i.e., the NP right-adjacent to the V° . Here the NP will be case-marked by the verb. Internal arguments can be objects of prepositions, in which case they are case-marked by the preposition, and it is the PP which is a sister to and is governed by the X° . There are also ditransitive verbs, where two NP arguments are both governed by the V° , and both receive case directly from

the verb.⁶ External arguments are always related to the XP via predication, which is to say the external argument of a head is the NP to which the maximal projection of the head is linked. This must be the case because XPs are always monadic functions, and thus can have only one external argument. They must all be linked to satisfy the predicate-linking rule. Therefore in order that this rule be satisfied the external argument must be in the position where it can serve as subject of the XP.

These three syntactic characteristics, i.e. receiving objective case from a verb, being the object of a preposition selected by a lexical head, and being the NP that an XP is predicated of, are the three syntactic indications of the fact that a thematic relation exists between the NP and the lexical head. The question which is of interest here is which type of thematic argument is realized by which method. If we assume the simplest possible theory, then a lexical head should be entered in the lexicon with an unordered list of arguments, and then general principles will determine how each type of argument is to be realized syntactically. Studies, such as those of Gruber (1965), Jackendoff (1972, 1975, 1976), Perlmutter (1978) and Marantz (1981) indicate that this is what seems to occur. Gruber and Jackendoff point out that an agent argument is always assigned to the external argument position, while the theme is always the [NP, VP]. Perlmutter claims that when a verb only has one thematic argument it is possible to use general semantic principles to predict whether that argument will be underlyingly external or internal. Verbs which have only an external argument

-- ergatives or "intransitive" in Burzio's (1981) terminology --
 have a D-structure representation (19):

(19) [NP [V]_{VP}]_S

Unaccusative verbs, which Burzio calls "unergative", have a single argument which by general principles is assigned to [NP, VP] position, with a D-structure representation as in (20):

(20) [[V NP]_{VP}]_S

Perlmutter does not in his 1978 article state the semantic principle involved, but he does suggest certain general deciding factors. For example, unergatives describe "willed or voluntary acts" and therefore assign agent theta-roles to their single arguments. These verbs include "work", "play", "speak", "talk", "grin", "frown", "enjoy", "swim", "run", "whisper", etc. They also describe certain involuntary bodily processes such as "cough", "sneeze", "hiccup", "belch", "burp", "vomit", where the theta-role assigned is not agent but what he terms "inalienable possessor." Unaccusatives include those verbs assigning the sole theta-role of patient, such as "burn", "fill", "drop", "sink"; verbs of existence and happening and aspectuals like "begin", "stop", "start", "cease". This class includes those verbs generally termed "inchoative", single argument verbs with transitive counterparts, where the surface-subject of the inchoative is the surface-object of the transitive verb, for

example those shown in (21):

- (21) John closed the door / The door closed
 Mary broke the vase / The vase broke.

Marantz (1981) makes the more general argument that the claims made by Jackendoff and by Perlmutter all follow from the same facts about the interaction of syntax and the lexicon. He argues that there is a parameter in universal grammar at which languages differ. Either they follow the pattern in English, where the agent or agent-like argument is external to the XP, and the patient or theme is internal, or the converse is true. The first type of language is the familiar nominative-accusative type, and the second is what Marantz calls "true ergative" languages. The languages of the world are overwhelmingly nominative-accusative ; so far there is clear evidence of only two true ergative languages, Dyirbal and Greenland Eskimo, analyses of which are presented in Marantz (1981, to appear).

The particular details of these various claims are not important -- what is essential here is not how the generalizations are characterized, but that there is evidence that such generalizations can be made. Such generalizations are part of what we learn when we learn a language. This means that given a sentence in which a particular lexical item is used, and given that knowing a lexical item is knowing what arguments it can take, there are sufficient general principles to determine what theta-role each syntactic argument must be assigned.

It is necessary to know exactly what arguments a lexical head requires because the syntactic configuration in which an argument appears at S-structure is not sufficient information to tell what its thematic role is. It is not possible to know what thematic role an [NP VP] with objective case has, without information about the lexical properties of the head. In the first place there is no one-to-one correspondence between position and theta-role.

Some NPs with objective case are patients, such as the object of the verb hit, others are not, for example the [NP, VP]s in John weighs 10 lbs., The book cost \$5, The twins resemble each other. Thus it is necessary to know what are the theta-roles that a head may assign, before deciding on a particular mapping between lexicon and syntax. In some cases other information is required, such as the configurational properties of the S. For example to interpret (22)

- (22) a. John gave the book to Mary
 b. John gave Mary the book.

it is necessary to know that give may assign objective case twice, in which case [NP₂VP] is assigned the patient role and [NP,VP] the goal or "dative" argument. Because of the alternation between the (a) and (b) forms, there is no general principle that the [NP VP] of give is interpreted as patient. (There is, however, a general principle of dativization which describes the relation between (22a) and (22b) as a particular instance of a more general rule

which states that verbs with thematic structure like that of give have these alternate forms available.

Another instance of objective case marking failing to indicate underlying grammatical relations is the objective case assigned by Exceptional Case Marking (ECM) verbs like believe. These verbs take an S' as argument, but exceptionally they assign objective case to the [NP S] of the S', just in case the lower clause is infinitival, as in (23):

- (23) John believed }
 thought }
 considered } her to be a genius

This is a syntactic indication of the peculiar fact that though her in (23) is thematically an argument of the VP to be a genius, and is the NP to which this VP is linked, it behaves syntactically as an argument of the matrix verb with respect to configurationally defined syntactic relations.

Yet another instance of the non-dependancy of case-marking and theta-role assignment is the assignment of case in idioms. The Case Filter as it stands states that all lexical NPs must have case; presumably NPs like the bucket in kick the bucket are no exception. However, it is a defining characteristic of idioms that the verbal heads do not specify thematic arguments, to fill the apparent syntactic argument positions, but that they demand specific lexical items, listed in the lexicon as cooccurring with the particular head, and as having fixed, non-compositional meanings.

In kick the bucket the NP has no literal meaning but together with the verb forms a single composite semantic unit meaning "to die." The whole unit -- verb plus specified lexical item -- forms a single lexical entry.

The respective thematic roles of NPs governed by prepositions are more transparent in the syntax. Prepositions are relational terms indicating relations of location on, by, near, to, etc.; relations of time -- before, after, during; relations of instrumentality -- with and through, and many others. The type of preposition thus indicates the type of thematic relation that its object will have to the verb. (There are, however, some "degenerate" PPs where the preposition doesn't indicate a relation of this type, but where the whole PP has an adjectival force. These PPs seem to assign theta-roles to the NPs they are linked to, and are interpreted semantically as predicates. Examples of such PPs are (24)

- (24) a. We thought him out of the country.
 b. They believed the cat in the garden.

These PPs must assign theta-roles to him and the cat, respectively, otherwise the NPs would be without theta-roles and the theta-criterion would be violated. Believe and think take clausal arguments, as we stated above, and theta-mark the whole clause, not the NPs that they case-mark.⁷ Thus there is no way for the NPs to be theta-marked other than by the PP.)

The syntactic realization of the thematic relation between a lexical head and its external argument is that the maximal projection of the head is predicated of the argument, i.e., that the former is linked to the latter by the predicate-linking rule. It is clear that case does not determine what the external argument of a head is. When an external argument is [NP, S] then it usually receives nominative case, but there are exceptions, e.g., the ECM examples, where the [NP, S] of the lower clause receives objective case from the matrix clause. But leaving these exceptional instances aside, there is also the fact that external arguments of secondary predicates are frequently not assigned nominative case. The subject of a secondary predicate is a thematic argument of another lexical head, and if it is an internal argument of this head, will receive case according to its position in the VP. Thus in (25)

(25) John eats them raw.

them, which is an external argument of raw, is also an internal argument of eats, and receives case from the verb, indicating this fact. That it is an external argument of raw is shown by the relation of predication holding between them and raw. Note that because the grammar allows the NP them to be an internal argument of one head and the external argument of another, it is necessary for theoretical reasons that some device other than case indicates at least one of these argument relations. If them is already case-marked by eat, it is not possible for the subject-predicate relation to be marked

by nominative case assignment. If this happens there would be a case-conflict, for the NP would be assigned two different cases by two different lexical items.

How can we test this claim that the syntactic encoding of a theta-role assignment is via predication? It is necessary to see what happens when a lexical head has a theta-role to assign, but where the only NP that the theta-role can be assigned to is not an NP it is predicated of. Such an instance occurs with NPs. The structure of an NP is (26)

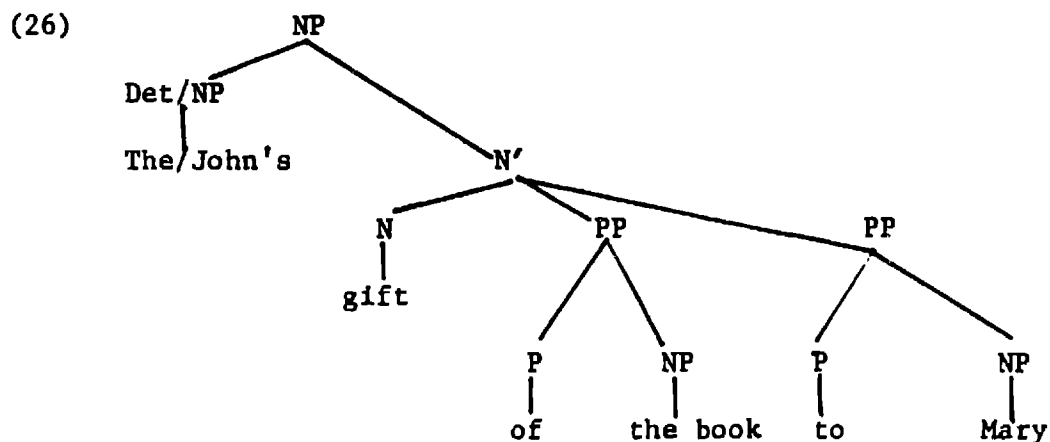

Here the head of the NP is gift which, like the verbal head give in (22), takes three thematic arguments; agent, patient and goal. Theta-role assignment must be syntactically encoded, and as nominals do not assign objective case all the arguments with the N' must be governed by a preposition. As in the VP in (22a) the goal argument is indicated by the preposition to. The patient is marked by of, a dummy preposition inserted at S-structure to assign case where the lexical head is [-V]. The agent argument has still to be

assigned, but the general rules of theta-role assignment designate agent as an external argument assigned through predication.

John, the [NP, NP] is the only NP available -- but the agent argument has to be assigned through predication. The expression "gift of the book to John" cannot assign the theta-role to anything via predication because it is not a maximal projection but an N', and thus cannot be predicated of an argument at all. As there is no predicate within the NP, there can be no subject either, for "subject" is defined as "subject of an XP". We can test the claim that John is not properly assigned a theta-role in an interesting way. We discussed earlier the fact that secondary predicates are predicates of NPs which are already arguments of another lexical head. In

- (27) a. John performed drunk,
 b. John gave the book to Mary drunk.

drunk is in each case the secondary predicate of the [NP, S] which is assigned a theta-role by performed and gave respectively. If the [NP, NP] is assigned a theta-role by the head of the NP then it too should be a possible subject for secondary predicates. If, as we have argued, the prenominal NP is not assigned a theta-role then it should not be possible for it to be the subject of a secondary predicate. This is in fact the case. Thus the following are unacceptable

- (28) a. *John's gift of the book late.
 b. *John's arrival in a hurry.
 c. *John's performance drunk.

Compare the perfectly acceptable predications within a gerundive nominal

- (29) a. John's giving the book to Mary late.
 b. John's arriving late.
 c. John's performing late.

Here the nominal has the structure [NP VP]_{NP}, i.e.,

- (30) [[John's] [performing drunk]_{VP}]_{NP}.

The [NP, NP] here is the subject of the maximal projection, and via predication, is assigned a theta-role by the head of the VP performing. It can therefore also be the subject of the secondary predicate drunk. In each of the examples in (28) the underlined XP is also supposed to be a secondary predicate of the [NP, NP], but because this NP does not receive a theta-role from another lexical head the secondary predication is impossible. The reason that the examples in (28) are interpretable, and by some people are considered marginally acceptable is that gift, arrival, and performance all have a theta-role to assign; it is just that there is no way of syntactically encoding this thematic relationship and

thus "properly" assigning the theta-role. However, it is possible to assign it "improperly" -- i.e., "match up" the [NP, NP] with the "floating" theta-role, even though there is no syntactic mechanism to encode this. Thus the John of (28c) can be understood as the agent of performance, and drunk is marginally interpretable as a secondary predicate of John because John is "improperly" assigned a theta-role in this way. Note that when the nominal head is non-derived and has no thematic arguments and thus no theta-roles to assign, there is no chance of even improper assignment of a theta-role to the prenominal NP and that NP is totally unacceptable as the subject of a secondary predicate, e.g.,

(31) *John's letter drunk.

To return to the central point: the main issue discussed here is that there are different ways of encoding syntactically the thematic relations between a head and its arguments and that there are general principles which map an argument of a specific thematic type onto a particular structural representation. The relevance of this to the general discussion of predicate-linking is that, depending on the thematic arguments which a head takes, it is possible for there to be no external argument, and therefore no NP for the predicate to be linked to. If a lexical head takes only a theme argument, and if, as in English, the theme is assigned to [NP, VP] position, then the D-structure representation will be of a predicate with no subject as in (32b):

- (32) a. John arrived
 b. $[[\text{arrived John}]_{\text{VP}}]_{\text{S}}$

If the lexical head originally assigned an external theta-role but underwent a lexical-morphological rule in the lexicon which deleted its external argument, then the D-structure representation will be analagous to (32b). For example, the relation between the active and passive forms such as John ate the cake vs. the cake was eaten, can, at least in part, be characterized by the fact that the passive construction does not have the external agent argument, which is obligatory in the active form. If general principles of theta-role assignment always have the theme realized as [NP, VP] then the D-structure of the passive sentence will be

- (33) $[[\text{was eaten the cake}]_{\text{VP}}]_{\text{S}}$

Here again the predicate is unlinkable, and if (33) is not modified in its mapping to S-structure, then the rule of predicate linking will mark the sentence as unacceptable.

In the next chapter we will discuss the rule of move-NP, and the process of pleonastic-insertion and cosuperscripting precisely as mechanisms to render structures like (32b) and (33) acceptable at S-structure.

3.4 In the previous section it was assumed that theta-roles are assigned to the D-structure external arguments by the head of the

XP predicated of it. An external argument linked to a VP is an argument of the V, the external argument of an AP is the argument of the A. This, however, is not an uncontroversial claim. Chomsky (1981) and Marantz (1981) both argue that the subject receives a theta-role from a maximal projection and not a lexical head. Thus in (34a)

- (34) a. John broke his arm.
 b. We found Bill proud of his new horse.

his arm is considered an argument of break whereas the [NP, S] must be an argument of broke his arm. Similarly in (34b) his new horse is an argument of proud, but Bill is an argument of proud of his new horse. This controversy is what I will examine in the final section of this chapter.

The claim that the external argument is not an argument of the head, but of the maximal projection of the head is an attempt to explain the asymmetry which there is between subject and object position. In the first place, the external argument, when it is an [NP, S] is not an obligatory theta-position. When, for example, the verb has passive morphology the external theta-role is not assigned. Further evidence for the asymmetry between external and internal argument positions is two-fold. First, it is claimed that the semantic nature of the XP determines the thematic role of the external argument whereas the external argument and the head can never together determine the thematic role of internal arguments.

Thus Marantz (1981) gives the following examples to indicate that object selection determines theta-role assignment to subject:

(35) (Marantz 2(35))

- a. throw a baseball
- b. throw support behind a candidate
- c. throw a boxing match (i.e. take a dive)
- d. throw a party
- e. throw a fit

- f. kill a cockroach
- g. kill a conversation
- h. kill an evening watching TV
- i. kill a bottle (i.e. empty it)
- j. kill an audience (i.e., win them)

Here the [NP, VP] does force a particular type of NP as external argument. On the other hand, in (36) the lexical subjects don't force a particular choice of semantic object:

(36) (Marantz 2(36))

- a. The policeman threw NP
- b. The boxer threw NP
- c. The social director threw NP
- d. Aardvarks throw NP
- e. Throw NP

- f. Harry killed NP
- g. Everyone is always killing NP
- h. The drunk refused to kill NP
- i. Silence can certainly kill NP
- j. Cars kill NP

This assymetry, that choice of object affects choice of subject, whereas choice of subject doesn't affect choice of objects, leads, it is argued, to the conclusion that the head alone determines the semantic nature of the object, whereas the head and internal arguments determine the semantic nature of the subject.

The second piece of evidence brought to support this assymetry comes from idioms. Marantz makes the observation that in English there are countless idioms such as kick the bucket involving V and internal argument but with a free subject. However, there are no idioms involving subject and verb with free internal arguments. If the verb selects for internal but not external arguments then this idiomatic combination of verb and object but not verb and subject is exactly what we would predict. On the other hand, if it is the VP which selects the subject, then we might expect to find VPs idiomatically combining with a fixed subject in phrasal idioms, only when the internal structure of the VP is also fixed idiomatically:

- (37) a. The shit hit the fan
 b. *The shit hit the airconditioner

Marantz suggest that there is a possible counter-example -- an idiom with fixed subject and free internal argument in the cat has got X's tongue. However, this is not a problem because the variable is not an argument of the verbal head get, but a determiner of tongue, and the fixed NP X's tongue is the fixed argument of V. It does not seem, however, that this evidence is sufficient to substantiate the claim that the choice of external argument is not projected from the lexical head, but is assigned by the head and its internal arguments together. This is not to dispute the importance or relevance of the asymmetries which Chomsky and Marantz describe, but rather to say that these facts are compatible with the theory of lexical entries presented here. More than that, the rules of syntactic analysis and semantic interpretation which were proposed earlier in this chapter and in Chapter II, explain and even predict the existence of exactly these types of asymmetries.

The analysis presented here is essentially simpler and more restrictive than the Chomsky-Marantz proposals. If it can account for all the same data, while maintaining that all lexical arguments are equally arguments of the head and without introducing new mechanisms for the assignment of external arguments, it is ipso facto to be preferred.

The fact is that the subject is a distinguished argument, and that aspects of its relationship to the head depend on the semantic properties of the maximal projection of the head. However, it is as much determined by the lexical head as the internal arguments are. In the case of throw (35a-e) the V assigns an agent role to its

external argument position and the "semantics" of throw indicate the relation which exists between agent and action. It is clear, however, that while the object is interpreted as "object of V," the subject is interpreted, both syntactically and semantically, as "subject of VP," and that in the examples in (35) the semantic content of the VP does force a specific interpretation of the agent-role. This results from the syntactic configurations in which the head and this particular argument occur, and from the semantic interpretation at SR. The syntactic encoding of the object relation is that it is assigned case by the verb so that syntactically, as well as thematically, it is an argument of the head. The [NP, S], however, is marked syntactically as being the external argument of V by the fact that the whole VP is predicated of it. Thematically it is the argument of the head, but syntactically it is the argument of the XP and semantically it is the notional subject of the predicate. The semantic asymmetries between subject and object are thus explained by the asymmetries in syntactic representation, and not by asymmetries in the lexical representation. The head determines the general nature of the external argument -- for example that throw requires an agentive subject--and the semantic component will determine what "sort" of agent this must be, depending on what property is predicated of it. The range of examples in (36) show only a few of the possibilities. Where a completely different thematic role is assigned for some sense of the verb then it seems we have a different homophonous lexical item, for example break, in John broke his arm vs. John broke the window.⁸ Not only

is this account of the assignment of arguments more restrictive, but it also allows a simpler account of the workings of the lexicon.

The lexicon, as we said above, consists (in part) of a list of lexical items. With each item comes certain information, including the number and type of thematic arguments it takes. Thus give and die, for example, will be listed as in (38)

- (38) a. give_v: agent patient goal
 b. die_v: experiencer

If the external argument is not assigned by the head, then this argument will not be listed along with the internal arguments as in (38), and the lexical entries will be as in (39):

- (39) a. give_v: patient goal
 b. die_v :

Within the lexicon it will not be possible to distinguish between die or run and other intransitives, and snow, which takes no arguments at all. The major problem with this theory of lexical entries is that lexical rules which operate in the lexicon can make no reference to the external argument because it isn't listed there. However, there are a great many lexical rules which make reference to external arguments, in fact Williams (1981) claims that lexical rules which affect argument structure always involve the subject (though some, e.g. Poser (1983) have pointed out that rules like dative movement, do refer only to internal

arguments). Passive and inchoativization, for example, both involve the deletion of the external argument. The rules will be discussed more fully in the next chapter, but as we have already mentioned, the rule relating (40a) and (40b) can be described as the addition of passive morphology and the deletion of the agent role from the list of the verb arguments.⁹

- (40) a. John ate the cake.
b. The cake was eaten.

The lexical entries for eat respectively are

- (41) a. eat_v: agent patient
b. eaten_v: agent patient

The passive rule formalizes the relation between (40a) and (40b) as a lexical redundancy rule. The rule of inchoativization works similarly. The relation between

- (42) a. John broke the window.
b. The window broke.

also involves the deletion of the agent argument, although unlike the passive rule, there is no morphological change to the verb.

The lexical entries (41a) and (41b) are

- (43) a. break_v: agent patient
 b. break_v: patient.

Whereas the D-structure of (42a) will be virtually the same as its S-structure, the D-structure of (42b) will reflect the underlying thematic relations:

- (44) [[broke the window]_{VP}]_S

and the move-NP rule will map (44) onto (45) in order to satisfy the predicate-linking rule, the trace indicating the

- (45) [[the window]_{NP} [broke t]_{VP}]_S

original theta-role assignment at D-structure.

If external arguments are not represented as arguments of the head in the lexicon, then it is difficult to maintain a statement of relations like these as lexical rules. Marantz does describe these processes as lexical rules, but he does so by making the structure of lexical entries more complex, and by introducing a level of grammatical relations into the lexicon. In his framework the lexical entry for the verb give is as in (46):

- (46) give: (patient goal): logical subject = agent

and the lexical rule of passive is stated as a rule mapping between thematic and grammatical relations in the lexicon. (46) is clearly more complex than (38): it requires a distinction to be made between predicate argument structure (the arguments in parentheses) and the external argument, and it also introduces a two-tiered system of grammatical as well as thematic structure. The simplest theory of argument assignment which we are proposing, which is that the external argument is assigned directly by the head, also allows the simpler theory of lexical representation.

Another argument in support of the claim that the external thematic argument is determined by the head, not by the maximal projection of the head, involves the discussion of (28) and (29) above. The explanation of the marginal status of (28):

- (28) a. John's gift of the book late
 b. John's arrival in a hurry
 c. John's performance drunk

is that the nominal head has an external theta-role to assign but that it cannot be properly assigned to the [NP NP] because assignment of this theta-role is via predication and there is no maximal projection of the head to predicate of the [NP, NP]. This implies that the external theta-role, which is improperly assigned to the prenominal NP in (28) and properly assigned to the [NP, NP] by the VP head in (29), is determined by the lexical head, and not by the XP. If it were only determined by the XP then there would be no

theta-role to assign even "improperly" in (29) and the examples would be as uninterpretable as (31).¹⁰

The second piece of evidence supporting the asymmetry between subject and object involved the non-existence of "object" idioms. The account of lexical representations and predicate-linking which we are developing predicts precisely these facts. The claim we have been making is that a maximal projection must be linked to an NP subject and that the preference of the grammar is that this NP is a thematic argument of the head. Pleonastics which are not cosuperscripted with a thematic argument are inserted as subjects only in the default case where there are no thematic arguments for the XP to be linked to. It is this fact which also explains the absence of object idioms. Idiom heads, like kick in kick the bucket do not assign theta-roles to their objects, but rather the V + NP form a single lexical item with a non-compositional meaning. In this instance the [NP, VP] doesn't even act as an independent syntactic argument -- hence the unacceptability of "the bucket was kicked by John." (There are idioms which do allow the [NP, VP] to act as independent syntactic, but not thematic, arguments, e.g. "advantage was taken of John".) Thus a sentence like John kicked the bucket has a simple thematic structure: the idiom VP with no internal arguments takes a single external argument. This conforms to a general principle that a VP is linked to a thematic argument when possible. If we take the putative idiomatic sentence (46)

(47) The bucket hit John.

where the bucket hit X means that "x was murdered," we have a sentence where the internal argument John is assigned a theta-role, but where the external NP is not theta-marked. This would conflict with the principle that the projection of a head which assigns theta-roles is linked to a thematic argument and not to a non-theta-marked NP. Phrasal idioms like "the shit hit the fan" will be permitted, because here the head has no theta-role to assign at all. These idioms are analogous to lexical heads like snow, which can be linked to pleonastic NPs because they have no thematic arguments to externalize at all.

We might ask why in languages which allow widely the cosuperscripting of a pleonastic subject with a thematic internal argument, it is not possible to have object idioms, where a thematic internal argument is cosuperscripted with idiomatic subject. If a language allows

(48) [[pleonastic]¹ [V NP¹]
 NP

where pleonastic and NP are coindexed and the [NP, VP] is interpreted semantically as the subject, why is it not possible to have

(49) [[the bucket¹]_{NP} [hit John¹]_{VP}]

where John and the bucket are coindexed, and John can be interpreted semantically as the subject. The answer is provided by the theory of case-marking: in (48) the cosuperscripting is possible because

the pleonastic and the [NP, VP] do not conflict in any features. In (49) however, the [NP, S], unlike the pleonastic, must be assigned case. According to Burzio, one of the reasons why cosuperscripting is required is that the pleonastic is assigned case, and by cosuperscripting can transfer it to the internal argument which, without this transference, would be caseless. However in (49) the [NP, VP] as well as the [NP, S] is assigned case, and cosuperscripting of these two NPs would result in an insoluble clash of case features.

FOOTNOTES

- (1) See Torrego (to appear) for evidence of this in Spanish and Catalan.
- (2) The Basic Works of Aristotle, ed. McKeon (Random House 1961).
- (3) We will discuss the role of there-insertion in Chapter IV.
- (4) Zagona (1982) suggests in her thesis that these constructions e.g. Sciva una lettera Giovanni are not instances of rightward move- α , but that the NP is at D-structure, post-verbal. Under this analysis, if no pleonastic pro is inserted, then leftward move- α would be necessary to satisfy the predicate-linking rule.
- (5) This means, of course, that the Aristotelian definition of a proposition as necessarily consisting of predicate, subject, and tense, has to be modified to account for these degenerate cases. The circumstances in which subjectless propositions are possible at the semantic level are extremely restricted. They occur only when the head of the predicate takes no thematic arguments at all. In English (as in many other languages) this occurs only with weather verbs.
- (6) Stowell (1981), who argues that case-assigner and NP must be adjacent, suggests that in ditransitive constructions a complex "word" is formed from the V + NP which assigns case to the [NP₂ VP].
- (7) It is interesting to note that the PPs which appear in this position tend to be those which can appear in [NP, S] positions as we discussed in 2.3, e.g.
- (i) We thought him in the garden.
- (ii) In the garden is a pleasant place to sit.
- (8) There are also instances of metaphorical usage:
- (i) John threw the news at us
- (ii) Silence killed the conversation

Here it appears that the thematic restrictions on what can be an argument have been relaxed. This is the opposite extreme from idiomatic usage. In an idiom the restrictions on what can fill the argument position are narrowed to a single lexical item. In metaphorical usage, the restrictions are weakened so that anything with the syntactic structure of an argument can fill the position. It is an interesting

line of research to investigate whether the same assymetry exists for metaphors as for idioms, i.e. that a metaphorical external argument is possible only when all the internal arguments are also metaphorical.

(9) The external argument can be reintroduced as an internal argument, governed by the preposition by.

(10) It has been suggested that the reason why

(i) John's arrival dead

is interpretable is not because of this theory of theta-role assignment, but merely by analogy with

(ii) John's arriving dead.

If this is the case, however, we would predict that

(iii) *Arrival dead

should be equally interpretable, by analogy with

(iv) Arriving deau.

However, (iii) is impossible. This is because there is neither a lexical NP nor a PRO in the (governed) [NP, NP] position to match up with the "floating" theta-role.

CHAPTER IV

4.0 We argued in Chapter III that it is a condition on well-formedness at S-structure that predicative XPs be linked to arguments, the subjects which they are predicated of. The preferred type of subject for an XP is an argument which is assigned a theta-role by the head of the XP. In some circumstances, the subject can be a pleonastic. In section 3.3 we showed that there are general principles governing the realization of theta-role assignments in the syntax. These ensure, among other things, that arguments of certain thematic types are assigned to "external" argument positions, where they automatically become the subjects of the XPs whose heads they are arguments of. The effects of these general principles are encoded in the D-structure representation.

It may happen that at D-structure, there is no argument for an NP to be linked to. This occurs when the arguments of a lexical head do not include one which, according to the general lexical principles, is assigned to the external argument position, either because, inherently, the head does not assign such a theta-role, or because that theta-role was deleted by a lexical rule. The predicate-linking rule is a condition on well-formedness at S-structure, so although there is no problem with an XP having no external argument at D-structure, this condition must be remedied in the mapping to S-structure if this latter representation is to be well-formed. In this chapter we will examine linguistic devices that ensure that predicative XPs do have subjects which they can be linked to at S-structure. The two

basic methods which we will examine are the move- α rule, and the use of pleonastics.

4.1.1 Move- α is a generalized movement rule, permitting the movement of constituents of various kinds, and constrained by general conditions on movement. These constraints are of several types; they include for example, the subjacency condition and other locality conditions indicating "how far" a constituent may be moved, and also binding conditions which detail from a different point of view, the possible relations between a moved element and the "trace" it leaves behind.

Different types of constituents may be moved by the rule. In wh-movement a question-word which is understood thematically as an argument of a head, is realized in S-structure at the beginning of the sentence, generated under the COMP node,¹

- (1) a. [He saw who]_S
 b. [[who]_{COMP} [did he see t]_S]_S

while a trace indicates the "original" location of the wh-word, that is, it indicates configurationally the relation between the wh-word and its head. Another movement rule is QR, the rule which assigns scope to quantifiers and which is part of the algorithm mapping from S-structure to LF. It is suggested (May 1977, 1982, Higginbotham, 1983b) that this rule of QR is another instantiation of the move- α rule, and that the algorithm mapping between S-structure and LF is (in this respect) a variation of the rule mapping from D-structure to S-structure.

The form of $\text{move-}\alpha$ which we are interested in is the move-NP rule -- though as we shall see, (4.4.2) move-argument is a more correct term to use since S' arguments as well as NPs are subject to it. Various aspects of this rule have been discussed in the literature (esp. Chomsky 1981, 1982) and principles governing the possibilities of instantiating the rule have been set out. For example, the rule move-NP is subject to the Empty Category Principle (ECP) which says that the trace left by an instance of move-NP must be properly governed. The trace of move-NP is considered an anaphor, so the rule is subject to opacity conditions which set out the possible configurational relations between an anaphor and its antecedent.

The aspect of move-NP which we will be concerned with here, is not the conditions on output, but the domain of application of the rule. We shall see that applications of move-NP are closely related to the necessity for satisfying the predicate-linking rule at S-structure; it is used just in case a D-structure representation has XPs which are neither arguments, nor predicates of anything.

4.1.2 There are two basic reasons why a non-argument-XP may lack an external argument at D-structure. In the first place, the head may simply not take a thematic argument which general lexical principles assign to the external position. A clear instance of this, as we mentioned in Chapter III, is the class of unaccusative verbs which have been analyzed as taking only one thematic argument, realized in [NP, VP] position at D-structure. (The most extreme case of heads with no external arguments is the set of heads which take no arguments

at all, for example weather verbs: rain and snow.) The second reason for a head having no external argument at D-structure is that a lexical rule deleted the external argument from the set assigned by the head. This is exemplified by cases of passive, where a lexical rule adds passive morphology and removes the external argument from the inventory of arguments. In Chapter III (41) we gave an example of the effects of Passivization on the lexical entry for eat.

What unaccusatives and passives have in common is that at D-structure the maximal projection of the lexical head has no subject. Examples of such representations are given in (2):

- (2)
- a. John arrived.
 - b. [arrived John]_{VP}
 - c. The cake was eaten.
 - d. [was eaten the cake]_{VP}

Because both arrive and was eaten take only D-structure objects so there is no external argument, and (2b) and (2d) contrast sharply with the unergative and active cases in (3):

- (3)
- a. John ran.
 - b. [[John]_{NP} [ran]_{VP}]_S.
 - c. John ate the cake.
 - d. [[John] [ate the cake]_{VP}]_S.

Here there is no difference between the D- and S-structure representations in the relevant respects.

It is in these instances that the rule of move-NP applies, moving the [NP, VP] to [NP, S] position so that the head will have an external argument at S-structure to be predicated of. As the (a) and (c) examples of (2) show, after movement the predicate-linking rule can be satisfied and the S-structures are perfectly well-formed. We have evidence that movement must take place between D-structure and S-structure in these cases. This evidence comes from the possibility of using resultative predicates with both unaccusatives and passives. As we showed in 2.4, resultative predicates may be predicated only of patient arguments of verbs of a specific semantic group (those describing a change of state of the object). Resultative predicates are selected by these verbs and are syntactic sisters of the head of the XP. They appear in configurations like (4):

(4)

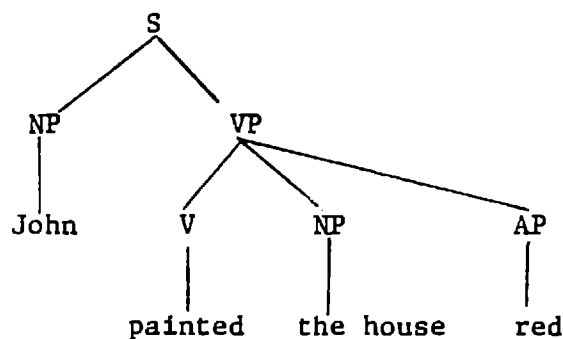

Because they are part of the VP, and because the relation between a predicate and its subject is one of mutual c-command, these resultatives can be predicated only of NPs which are also syntactic sisters of the

V°. Yet we find resultative predicates with both unaccusative and passive verbs:

- (5) a. The river froze solid.
 b. The house was painted red.

At S-structure, where the predicate-linking rule must be satisfied, the predicates solid and red do not c-command the river and the house respectively. However, the [NP, S] in both these examples have been moved from the [NP, VP] position leaving behind a trace:

- (6) a. The river_i[froze t;solid]_{VP}
 b. The house_i[was painted t;red]_{VP}

In each case the predicate and the trace of the subject do c-command each other, and the predications are acceptable (cf. 2.4). When the resultative predicate is predicated of an [NP, S] subject which is not coindexed with an [NP, VP] trace, the sentence is not well-formed:

- (7) *John ran exhausted (i.e. till he was exhausted)²

Move-NP then operates as a mechanism for ensuring that the predicate-linking rule be satisfied at S-structure when general lexical principles do not ensure a theta-marked argument in the [NP, S] position.

It is important to note that under this analysis the process of passivization is split into two parts, a lexical rule, and an instance of $\text{move-}\alpha$, while no lexical rule governs the behavior of unaccusative verbs at all. The lexical rule of passive deletes an argument and adds morphology. The movement follows automatically from the need to fulfill the condition on predicate-linking. With unaccusative verbs no lexical rule is involved. These verbs inherently lack a thematic external argument. The movement rule again allows them to satisfy the requirement that all predicative XPs have a formal subject at S-structure.

4.2.1 There are cases where an application of $\text{move-}\alpha$ will not provide an external argument for a maximal projection and the XP will remain unlinked at S-structure. This is the case with heads which assign no theta-roles at all. Move-NP cannot move an argument of the head to the external position because the head has no arguments, external or internal. In English this occurs in the case of the weather verbs, for example snow and rain. It is clear that no lexical NP can be the subject of these predicates because any lexical NP would have to be assigned a theta-role, and these heads have no theta-roles to assign. Sentences like (8) are thus impossible:

- (8) a. *Snow snows.
 b. *The clouds rained.

In these instances, where a predicate has to have a subject, but a non-lexical subject, English allows the insertion of the pleonastic it, which has no thematic content, and thus requires no theta-role. The predicate-linking rule can now be satisfied at S-structure, without the theta-criterion being violated.

The well-formed S-structure of sentences like (8) is of course (9):

(9) It rains.

Sentences like (9) occur in English only when a lexical head takes no arguments. The problem of what to do with snow can be seen as an extreme case of unaccusativity. Unaccusatives have no underlying external argument and so the internal argument is externalized by move- α . Weather verbs have no underlying external argument either -- but neither do they have any internal arguments, so the move- α solution is no help with them. The device of pleonastics is then used. In some languages -- notably German and Dutch -- an analogous problem arises with the output of lexical rules. In English, the passive rule only applies to verbs with external arguments and internal arguments, i.e. to what are called transitive verbs. Passive morphology and the concomitant deletion of the external argument does not occur with unergatives. The passive rule can apply to hit, and eat, and etc., but not to run or swim. As passive applies only to transitive verbs in English, there is always an internal argument to be moved by move- α

to the external argument position at S-structure. However, in German and Dutch passive morphology may be added to a single argument verb, and its single, external argument is deleted. This leaves the verbal head in a position identical to snow with respect to thematic arguments, i.e. with no arguments to be moved to [NP, S] position. For example, there are passive forms of verbs such as "dance," "work," "ski," and "sleep." In the active form, these are single argument verbs and in the passive form they have no arguments.³ Some examples are given from Dutch:

- (10) a. Er wordt hier door de jonge lui veel gedanst.
 "It is danced here a lot by the young people."
- b. Er wordt in deze kamer vaak geslapen.
 "It is often slept in this room."
- c. Er wordt hier veel geskied.
 "It is skied here a lot."

As with the weather verbs in English, there is no thematic argument of dance, sleep, or ski, for the VP to be predicated of, therefore the pleonastic er is inserted as a formal subject.

The analysis of (10a-c) is complicated by the fact that Dutch, like German, is what is called a V_2 language, i.e., a verbal element must be the second constituent in a sentence. These languages have been analyzed (den Besten (1978), Thiersch (1983 personal communication)) as having the basic sentential structure shown in (11):

- (11) a. V_2 (mittelfeld)
- C_1 [C_2 [NP NP V V]_S]_{S'}
- [-INFL] [+INFL]

b.

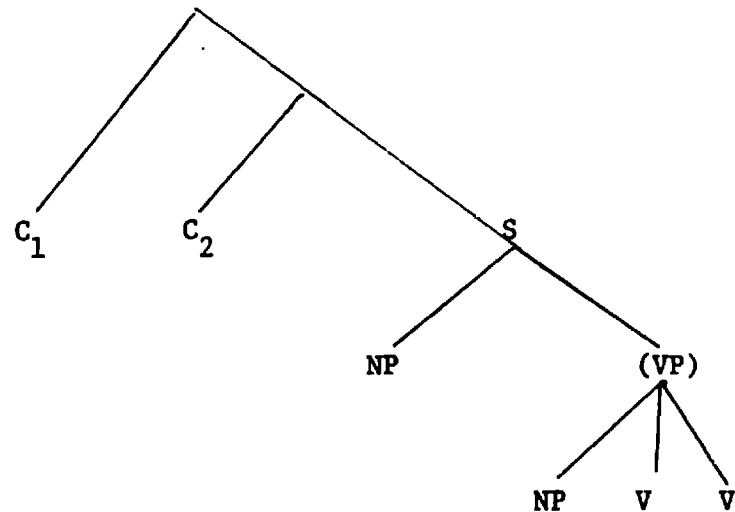

(V_2)

(mittelfeld)

The sentence consists of two constituents (C_1 , C_2) followed by an S. The S, which is traditionally termed the mittelfeld, consists of a VP (whether virtual⁴ or actual) and an [NP, S], the external argument. The VP consists of a string of nominal arguments, followed by the verbal elements, a head which may be followed by modal and auxiliary nodes. V_2 , the second constituent in the sentence, is filled by COMP in subordinate clauses, and in matrix clauses by a [+INFL] verbal element moved from S. The V_2 + S can thus be considered as forming an S'. A nominal or other [-INFL] constituent such as a locative PP,

is also moved from S to the C_1 position. (Note that if the V_2 position is analyzed as COMP so that $V_2 + S$ form an S' , then the predicate-linking rule predicts the necessity for a [-INFL] C_1 position because the S' , like all maximal projections, will have to be linked to a formal subject at S-structure. In English, in matrix sentences, there is no V_2 position; a matrix clause is not an S' , but a non-maximal S. It does not, therefore, require linking to a formal subject.) The S-structure of a simple active sentence like (12) will be as in (13)

- (12) De edelen buigen voor de konig.
 "The nobles bow before the king."

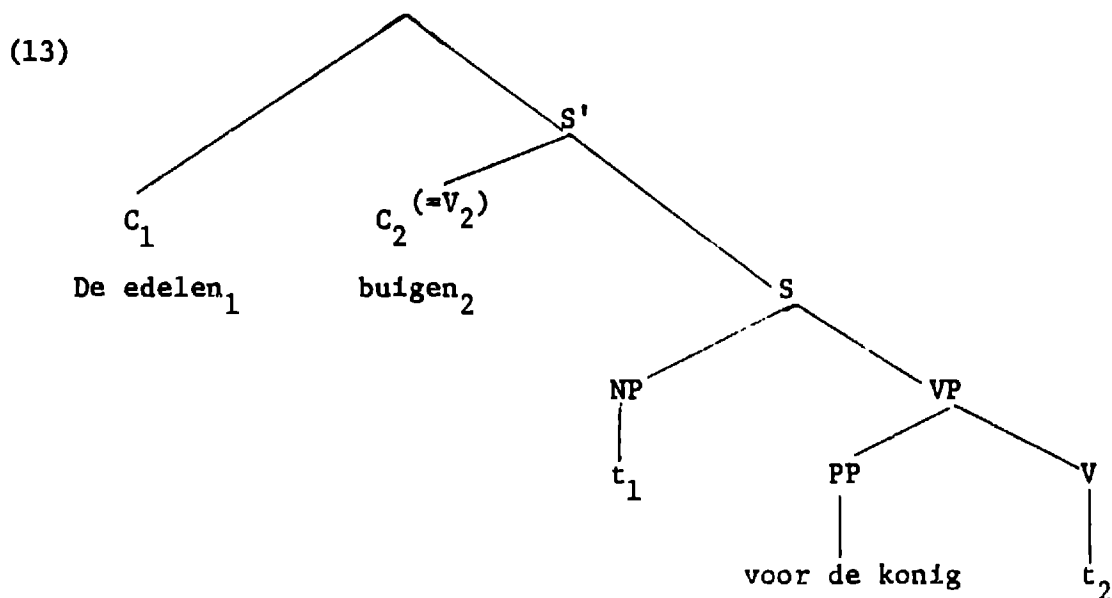

The representation of an impersonal passive like (10c) will be very similar:

(14) (=10c)

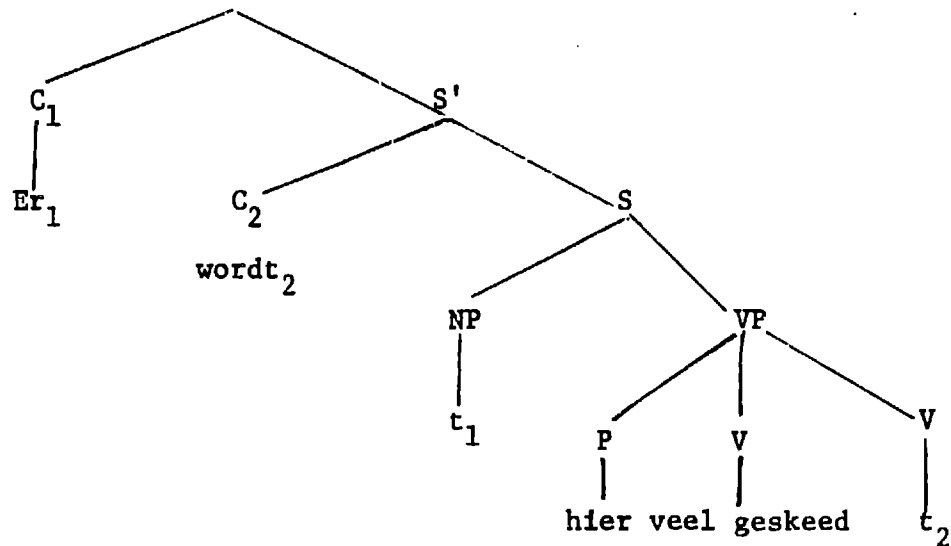

The verb ski has had passive morphology added, and its agent argument deleted. It now has no arguments. The [VP, S] hier veel geskeed wordt has no external argument, thus the pleonastic er is inserted as formal subject. Then the [+INFL] element wordt is moved to the C₂ (V₂) position, and the nominal er is moved to the C₁ position to become the formal subject of the S' as well as of the VP.⁵ Thus we can see that the pleonastic er is used here in basically the same way that it is used in English. They are both inserted at S-structure to act as formal subjects of predicates just in case the head of the predicate has no thematic argument to be predicated of. The use of pleonastics is thus a syntactic mechanism to provide a formal subject for predicates with no thematic subject.

4.2.2 It is a universal fact that it is not possible to form passives from unaccusative verbs. In English (15b) is an unacceptable attempt to passivize (15a):

- (15) a. John shaved,
 b. *It was shaved (by John).

In English this can be explained by the fact that passive applies only to verbs with both an external and internal argument, but this explanation cannot account for the cross-linguistic examples. In Dutch, German and Icelandic, where impersonal passives formed from single argument verbs are common, it is the case that there are no acceptable passives formed from unaccusatives. The examples in (10), from Dutch, and in (16) from Icelandic, are all formed from unergative verbs,

- (16) a. það var hlegid
 "it was laughed"
 b. það var synt
 "it was swum"

i.e. single argument verbs which have an external argument at D-structure, but no internal argument. The (b) examples in (17) and (18) which are "passivized" unaccusative verbs, are not well-formed:

- (17) (Icelandic)
 a. Veizlan stod lengi
 "The feast lasted a long time."

b. **bad* var lengi stadid.

"it was long lasted"

(18) (Dutch)

a. De sneeuw is van het dak afgegleden.

"The snow slid off the roof"

b. *Er werd door de sneeuw van het dak afgegleden.

"It was by the snow slid off the roof."

Perlmutter (1978) proposes that there is a universal principle, the one advancement exclusiveness law, which states basically, that in a given construction, only one internal argument can be moved to subject position. This accounts for the ungrammaticality of passivized unaccusatives in the following way. Unaccusative verbs have only an underlying deep object. This is "advanced" to subject position in an ordinary active sentence, for example, (15a), (17a) and (18a). Passivization of these forms leads to the advancement of the dummy pleonastic to subject position in the (b) examples. In these sentences there have therefore been two advancements to subject position, and the sentences are ungrammatical. Impersonal passives can be formed only from unergative verbs. Here there is a D-structure subject, and the advancement of the pleonastic to [NP, S] is the single advancement within the sentence, so the construction is well-formed.

Within the framework of the analysis presented here, the unacceptability of (15b), (17b) and (18b) falls out automatically from

the statement of the passive rule, and no stipulative law, even a universal one, has to be set out. The passive rule is a lexical rule, performing operations on lexical forms. It adds passive morphology, and deletes the argument indicated in the lexicon to be externalized (optionally adjoining it to the VP, marked with a preposition). In English it applies only to verbs with an external argument and an internal "patient" argument, such as give or eat. In Dutch it applies to any verb with an external argument, for example zwenmen, "to swim." It is thus impossible for the lexical rule of passivization to apply to unaccusative verbs because they do not have arguments which are perceived in the lexicon as being external. They do not, in fact, have external arguments, except, as a result of $\text{move-}\alpha$, at S-structure. This is because the advancement of the unaccusative verbs single argument to subject position is not a lexical rule but the result of the application of the structural rule of $\text{move-}\alpha$ at D-structure.

This is the crucial difference between Perlmutter's analysis and the one presented here. Perlmutter's framework allows, in principle, multiple advancements to subject position and therefore requires a law to rule such advancements out. We have argued that $\text{move-}\alpha$ applies to a D-structure representation of a sentence S, moving an argument of the head to [NP, S] position, so that S satisfies the predicate-linking rule. Advancement to subject position is always and only via the application of $\text{move-}\alpha$ in this way, hence it can never occur that there are two advancements to subject position in a single derivation. Once the rule has applied the first time, the

S-structure is derived, and the predicate linking rule must be satisfied. In order for a sentence like (17b) to be derived, the externalization of the internal argument which resulted in (17a) would have to be the result of a lexical rule. It is a claim of our analysis that no such lexical rules exist. A lexical rule may delete an argument marked in the lexicon as externalized, but it may not externalize an internal argument, for that is the function of the syntactic rule of move- α . It is therefore an empirical prediction of this analysis that there will be no need to promote internal arguments to subject position by lexical rules.

4.3.1 We have so far discussed the fact that when an XP does not inherently have an external argument, assigned to that position by general lexical principles, then an internal argument is moved by move- α , whenever possible, to the external position to be the formal subject of the predicate. (Note that only NPs seem to be moved by this rule: PP arguments remain internal. PPs, like all XPs, require formal subjects, and moving a PP to [NP, S] position would result in a sentence that was not well-formed, for in that position there is no argument for the PP to be a predicate of.) In English, and other Germanic languages where the mapping from D- to S-structure fails to provide a formal subject for an XP, a dummy pleonastic is inserted at S-structure. Pleonastics are thus used only as a "last resort" when no thematic argument is available to be the formal subject. In the Romance languages, in particular, the so-called "pro-drop"

languages such as Italian and Spanish, use of pleonastics is much more widespread. The vocabulary of these languages includes the null pleonastic pro which can be inserted in [NP, S] position as a formal subject in a wide variety of circumstances. The sets of circumstances which interest us here are two; firstly the lexical subject can be moved to the right and adjoined to the VP and the pleonastic pro can be inserted in its place and co-indexed (cosuperscripted) with it:

- (19) a. [Giovanni [scrive una lettera]_{VP}]_S
 b. [proⁱ [[Scrive una lettera]_{VP(nonmax)} Giovanniⁱ]_{VP(max)}]_S

"Giovanni writes a letter."

Both (19a) and (19b) are equally acceptable as the Italian equivalent of the English sentence. The pro acts as the formal subject of the VP, and the NP Giovanni, because it is cosuperscripted with the [NP, S], can be interpreted by the semantic component as the notional subject. In the second case, the pleonastic pro can be inserted, just in case move- α would have had to apply to provide a formal subject for the VP. This occurs, as in the Germanic languages, where the verbal head is a passive, or an unaccusative, e.g. (20):

- (20) a. [Molti studenti₁ [furono arrestati t₁]_{VP}]_S
 b. [proⁱ [furono arrestati molti studentiⁱ]_{VP}]_S

"Many students were arrested."

- (21) a. [Molti studenti₁ [arrivano t₁]_{VP}]_S
 b. [proⁱ [arrivano molti studentiⁱ]_{VP}]_S
 "Many students arrived."

Again, the pro acts as the formal subject, and is cosuperscripted with the internal NP which would have been moved, had move- α applied. It is clear that in these cases the cosuperscripted lexical NP is underlyingly the [NP, VP], whereas in (19) this is not the case, because of the possibilities of ne-cliticization. Ne-cliticization is possible only when the NP replaced by the clitic is an [NP, VP] at D-structure.

- (22) a. Molti studenti arrivano.
 Arrivano molti studenti.
 Ne arrivano molti.
 "Many of them arrived."
- b. Molti studenti furono arrestati.
 Furono arrestati molti studenti.
 Ne furono arrestati molti.
 "Many of them were arrested."
- c. Molti studenti telefonano.
 Telefonano molti studenti.
 *Ne telefonano molti.

Ne-cliticization is possible with an unaccusative verb, and with a passive construction, but not with an unergative verb like telephone in (22c), even if the lexical [NP, S] has been adjoined to the VP and cosuperscripted with a pro-subject. (It is important to note that the indices assigned by cosuperscripting are not the same as those assigned by coindexing under the binding theory. The binding theory is concerned with properties of coreference, whereas what is at stake here is the satisfaction of the predicate-linking rule, and the proper assignment of case to all NPs, as we will discuss below. Any analysis which collapses these two processes into a single schema for assigning indices must also take into account the different roles of each.)

The possibility of inserting a pleonastic and cosuperscripting it with a post-verbal NP is available in Italian and Spanish but not in English (except in the lexically restricted instances of there-insertion). Chomsky (1981) argues that this is due to the fact that English and Italian differ at a single (relevant) parameter, whether AGR (the nominal "agreement" element of inflection) is adjoined to the V-node in the syntactic component or the phonological component. An S-structure schema for a sentence is

(23) NP INFL (AGR) VP

but phonologically AGR is always realized morphologically as affixed to the verb. Chomsky proposes that in Italian and other pro-drop

languages, the affix-hopping rule which adjoins AGR to the verb applies optionally in the syntax, whereas in English, it must apply only post-syntactically. The parameter is stated as in (24):

(24) R (the rule of affix-hopping) may apply in the syntax.

The effects of (24) are two-fold. AGR is a governing element, so that when it applies in the syntax, the output is as in (25), and the [NP, S] position is ungoverned:

(25) [NP [V + AGR NP]

This means that a pleonastic pro, which requires to be ungoverned at S-structure, can be inserted in the [NP, S] position. In languages such as English and French, where R does not apply in the syntax, [NP, S] is governed by AGR at S-structure, and a pro pleonastic cannot be inserted. The second consequence of (24) is that when AGR is adjoined to V in the syntax, the post-verbal NP is governed by AGR and may be assigned nominative case. The system of cosuperscripting ensures that the right NP gets nominative case. AGR is cosuperscripted with the [NP, S] (i.e. pro) before movement, and the pro is cosuperscripted with a post-verbal NP. Only if all three indices agree can case be assigned to the post-verbal NP. Sentences like (19) will have an S-structure representation as in (26):

(26) [proⁱ [[[Scrive + AGRⁱ] una lettera]_{VP} Giovanniⁱ]_{VP}]]_S
max

Here pro is cosuperscripted with AGR and with Giovanni, and this NP is assigned case under government by AGR. (Note that, as we argued in 2.4, the maximal projection of the V is defined relative to a particular S. The maximal projection of V in (26) is the full VP scrive una lettera Giovanni, while if Giovanni had remained in [NP, S] position the maximal VP would have been simply scrive una lettera). If, in (26), the relevant index had been assigned to una lettera and not to Giovanni, then the sentence would not be well-formed. The NP una lettera would be assigned both nominative and objective case, and Giovanni would be assigned no case at all. Thus because of the choice which these pro-drop languages make at parameter (24), they have another option for satisfying the predicate-linking rule.

4.3.2 The question which obviously arises next is whether there is a connection between the use of pleonastics in English-type languages and in Italian-type languages. In fact, it seems that there is a connection, and that a single rule interacting with parameter (24) will account for the distribution of pleonastics in both language-types.

As we showed for Italian, the pleonastic subject is cosuperscripted both with the nominative-assigning AGR, and the nominative-marked NP. The S-structure representation is as in (27a) before AGR is moved, and as in (27b) afterwards:

- (27) a. [pleonasticⁱ AGRⁱ [V NPⁱ]_{VP}]
 b. [pleonasticⁱ [V + AGRⁱ NPⁱ]_{VP}]_S

There is a general rule which cosuperscripts [NP, S] and AGR⁶ and also a pleonastic and NP, at the stage at which pro is inserted. We will assume that the same rule of cosuperscripting applies in English. Suppose that we have a D-structure representation of The cake was eaten to which move- α does not apply. The S-structure representation will then look like (28):

(28) [AGR [was eaten the cake]_{VP}]

(28) does not satisfy the predicate-linking rule, and at S-structure it is too late for move- α to apply so the only option is to insert a pleonastic it. In order that nominative case is assigned, AGR and it

(29) [itⁱ AGRⁱ [was eaten the cakeⁱ]_{VP}]_S

are cosuperscripted. (We can assume that this cosuperscripting is part of the nominative case-assignment mechanism.) The insertion of a pleonastic is accompanied by an automatic co-superscripting with a post-verbal NP. The outcome of this is indicated in (29). However, because affix-hopping (R) does not happen in the syntax, case-assignment in English must precede move-AGR. As case is assigned only under government, AGR cannot assign case to the NP the cake, despite the matching cosuperscriptions. This accounts for the impossibility of sentences like (29) in English.

The prediction that is made by this analysis is the following: pleonastics can be inserted in English only in case they are not cosuperscripted with an NP which requires case. As a pleonastic must be cosuperscripted with an argument if there is one, they can occur where there is no post-verbal argument, as occurs with lexical heads like snow. They can also occur when the post-verbal argument does not require case, for example, when this argument is an S'. In (30)

- (30) a. That John is tired is certain.
 b. It is certain that John is tired.
 c. John is certain to be tired.

the adjective certain takes a single internal argument, the S' so that the D-structure representation of (30) is (31):

- (31) [is certain [that John is tired]]_{VP}

In (31) the VP has no subject, and (30) shows the three possible ways of providing a formal subject at S-structure. In (30a) the whole argument has been moved to the subject position and the VP is linked to it. In (30c) S' deletion has taken place and the [NP, S] of the embedded clause has been moved to act as formal subject for the whole VP.⁷ But in (30b), a pleonastic has been inserted and cosuperscripted with the internal S', and the predicate-linking rule is satisfied in exactly the same way as in (26).⁸

Note, however, that the following sentence is not acceptable:

(32) It¹ was given to Mary,¹

where it is pleonastic, and is coindexed with the goal argument, a PP, even though Mary is not dependent on AGR for case. The pleonastic cannot be coindexed with a PP, but only with an NP, or with an S', as the examples in (30) show. It seems that the cosuperscripted argument must be one which potentially could have been moved by move- α to the [NP, S] position, resulting in a well-formed representation. As a rule PPs cannot be moved to this position because they have to be linked to subjects and thus cannot be subjects of predicates themselves. An area for further investigation is whether languages which freely allow locative PPs in [NP, S] position also allow pleonastics to be co-superscripted with internal locative PP arguments.

As it stands, this analysis does not account for there-insertion in English, or the particulars of il-insertion in French. There behaves differently from it. It is lexically governed, appearing only with verbs of certain types. It must be cosuperscripted with an indefinite NP which is assigned case, and the matrix verb must agree in number with the cosuperscripted NP, as in (33)

(33) There¹ were three men¹ in the garden.

Il has similar properties to there; it is also lexically governed and is coindexed with a case-marked indefinite NP, but the matrix verb in French is always 3.p.s. as is normally the case with verbs with pleonastic subjects.

- (34) Il^i est arrive 3 garcons.ⁱ
 There arrived 3 boys,

Essentially, there and il have the same function as it and pro; they are formal, non-thematic subjects inserted at S-structure, and cosuperscripted with the argument to be interpreted as the notional subject. The differences between these pleonastics and pro and it are due to other factors. Safir (1982) suggests that there, unlike it, is able to form a "chain" with the NP that it is cosuperscripted with, and thus to transfer nominative case to that NP without its being governed by AGR. It appears that it is a particular property of these items that they can enter into such constructions.

4.4.1 We have discussed the rule of move-NP ((or move-argument) as the examples in (30) show) as a mechanism for ensuring that the predicate-linking rule is satisfied at S-structure. As we saw in 4.3, if move- α does not apply then it is in some circumstances possible to "save" the structure by inserting a pleonastic and cosuperscripting it with an argument of the head. Exactly where this is possible depends largely on whether (24) holds true in the language.

This characterization of movement, and its role in passive and unaccusative constructions differs from other analyses of these constructions within the government-binding framework. These have given characterizations of the movement rule in terms of principles of case-assignment and theta-theory, and in particular have relied heavily on "Burzio's generalization" (Burzio 1981). I shall argue here that Burzio's generalization, stated in its present form, does not hold; and that even if it is modified so that it is empirically correct, it is relevant to a discussion of movement of arguments only in some languages. A characterization of $\text{move-}\alpha$ with respect to constructions like passive and unaccusative, has to be stated in terms such as those set out in 4.1-4.3, if it is to have wide cross-linguistic relevance.

Burzio makes the observation that verbs that assign accusative case (we will call this property "A") also assign a theta-role to a D-structure external argument (i.e., have the property "T"), and conversely. Within Burzio's framework, the property T holds of a verb if it assigns a theta-role to subject position. In the context of this discussion the two definitions of "T" are interchangeable. The following biconditional expresses the generalization:

(35) - T \leftrightarrow - A.

(35) may be broken into two conditionals (36a-b), which rule out structures (37a-b) respectively.

- (36) a. - A \rightarrow - T
 b. - T \rightarrow - A

- (37) a. * [V [NP]]_{VP}
 [+θ-role] [+θ-role]
 [-Acc case]

- b. * [V [NP]]_{VP}
 [-θ-role] [+θ-role]
 [+Acc case]

(36a) states that whenever a verb does not assign accusative case it will not take a D-structure external object. This is a generalization about -A verbs, which is derivable from the theta criterion and the case filter (38)

- (38) * NP
 [+lexical]
 [-case]

If a verb is -A, but has an internal argument, then that argument must still receive case, otherwise it violates (38). There is no way for it to be case-marked, other than with nominative case, so it must be moved to [NP, S] position where it can be so case-marked. This is the position to which the external theta-role is assigned, and unless the verb is -T, movement to this position will violate the theta-criterion. If the verb is +T, then the [NP, S] position

should have been filled at D-structure, and clause (1) of the theta-criterion prevents more than one argument filling a single theta-position. (If the [NP, S] position was not filled -- i.e., if there was a degenerate D-structure, movement to [NP, S] will still be prohibited, for the theta-marked [NP, VP] would then receive a second theta-role, also ruled out by the theta-criterion.) (36a) must therefore be a property of those verbs whose internal arguments are subject to move- α , such as passives and unaccusatives. (36b) says that whenever a verb assigns no external argument, it also does not have the property of assigning accusative case. This is logically equivalent to $A \rightarrow T$, which says that every accusative-assigning verb will also assign a theta-role to its subject position. Structures like (37b) are ruled out by this, because if the accusative-marked [NP, VP] were moved to [NP, S] it would receive nominative case, and the structure would be unacceptable because the NP had received case twice.⁹

(35) thus states the properties which verbs must have if the movement rule can operate in the grammar. A case-marked NP cannot be moved to a position where it will receive case again and a theta-marked NP cannot be moved to a position where it will receive another theta-role. (35) has thus been identified as a necessary and sufficient condition on movement (Chomsky (1981) class lectures) and it has been suggested that the connection between (35) and instances of move-NP is causal. If it is true that (35) is a necessary and sufficient condition for movement then it must be the case that in every instance

where there is movement from the VP, the head of the V must have the properties of (35). This is formalized in (39):

- (39) Move-NP occurs in a derivation if and only if the NP, α , is in a position to which accusative case is not assigned and there is an $[e]_{NP}$ to which a θ -role has not been assigned.

(39) allows for a characterization of passive in terms of case-assignment. The crucial properties of passive are held to be (1) that a passive verb does not assign a theta-role to its subject and (2) that passive morphology "absorbs" accusative case. Movement in passive is then accounted for by the facts that a passive verb is -T and -A and that (39) holds true.

The point I shall make in this section is the following. Even if (35) and (39) hold true, it is not clear that the best characterization of constructions like passive is in terms of case-assignment and theta-role assignment. It is logically possible that a characterization be given in terms of some other property P. I suggest that there is such a property, which is the condition that the predicate-linking rule be satisfied.

There is empirical evidence in support of this thesis. Firstly, there are instances, where (35) does not hold true. Magnus (1983) discusses examples of this from Norwegian. I shall present counter examples, specifically to (36b), from Russian, Icelandic and Basque. Secondly, if we weaken (35) so as to take account of these examples, it will still be the case that (39) is not valid -- and that there

is evidence that move-NP applies to an NP which does receive case from the verb which governs it. It can, however, be argued that move-NP applies when and only when the predicate-linking rule must be satisfied. The absence of a formal subject for a VP at S-structure is a necessary and sufficient condition for the application of move- α to the [NP, VP].

4.4.2 There are instances in both Russian and Icelandic of verbs which contradict (35) and (39). Pesetsky (1982) presents two classes of Russian verbs which are -T and +A, violating (36b). The first examples are verbs describing "natural disasters" which have a transitive +T, +A form, as in (40), but also an impersonal -T, +A form as in (41):

(40) Voda zalila ulitsu.
 water-NOM flooded-PF the street-ACC
 "The water flooded the street".

(41) a. Ulitsu zalilo vodoj.
 street-ACC flooded-PN water-INST
 "The street was flooded with water."

b. Izbu zaneslo snegom.
 hut-ACC cover-PN snow-INST
 "The hut was covered with snow."

These impersonal verbs take no overt NP with nominative case, and are always third person, neuter, singular in form. They are clearly -T, and we have evidence that the accusative NP is still the underlying D-object assigned case by the verb. These accusative NPs can appear marked with the genitive of negation, a property of D-objects alone:

- (42) a. Ni odnoj ulitsy ne zalilo vodoj.
 not one-GEN street-GEN neg. flood-PN water-INST
 "Not one street was flooded with water"
- b. Ni odnoj izby ne zaneslo snegom
 not one-GEN hut-GEN neg. cover-PN snow-INST
 "Not one hut was covered with snow."

The second group of -T, +A verbs includes those expressing physiological states. These take one NP argument, the structural subject which is assigned accusative case, but which can also appear marked with the genitive of negation, indicating its underlying D-object status

- (43) a. Menja mutilo.
 I-ACC feel sick-PN
 "I feel sick"

b. Ni odnoj debushki ne mutilo.

Not one-GEN girl-GEN neg. felt sick-PN

"Not one girl felt sick."

In Icelandic (Levin, L. 1981, Andrews, 1982) there are widespread examples of what has been called "quirky" case. Verbs case-mark their objects with non-accusative case, and these quirky case-marked NPs then appear as S-structure subjects of unaccusative and passive verbs. Examples of unaccusative verbs are given in (44) and of passive in (45) and (46):

(44) a. Mig (A) kelur (acc. subject).

I am getting frost-bitten/am freezing.

b. Mér (D) líkar þeir bílar (dative subject).

I like these cars.

c. Verkajanna (G) gaetir ekki (genitive subject).

The pains are not noticeable.

(45) a. Jón kastadi steini-DAT.

John threw a stone.

b. Steini-DAT var kastad.

The stone was thrown.

- (46) a. *Þu* beiddist *mín*-GEN.
 you awaited me , .
- b. *Mín*-GEN var beidd,
 I was awaited ,

In (45) and (46) we have clear examples of a verb specifying the case it assigns its D-object, and that NP continuing to receive the specified case from the verb even when it is not in [NP, VP] position. These verbs are not +A, in one sense, because it is not accusative case which they assign, but they are -T, +case assigners. It does not seem plausible to say that movement of an NP in the (b) examples is in order that they be case-marked, because in the first place they are assigned case by the verb, and in the second place, if they moved to [NP, S] to be assigned case by INFL, we would expect them to receive nominative case. The same argument holds in (44). These verbs are semantically unaccusative and are analyzed as taking one internal argument. They also show syntactic properties of unaccusativity in that they are always 3-neuter-singular in form. It is presumed that case assigned by INFL will always be nominative, so the analysis proposed for (44) is that the S-structure subject is an internal argument of the verb, case-marked, under government, by the verb. Unaccusative verbs, like the passive verbs in (45) and (46), violate (36b) in that they are -T, but do assign case to their direct objects. They thus also violate (39a) in that we have instances of move-NP where Burzio's generalization does not hold.

It is clear that there are many instances of move-NP in Icelandic where Burzio's generalization does hold, and where patterns of case-assignment are those familiar from English. Many instances of passive are like (47):

(47) a. Þjofurinn-NOM raendi bankann-ACC.

The thief robbed the bank.

b. Bankinn-NOM var raendur.

The bank was robbed.

It is only when the case assigned is "quirky" that the generalization does not hold. L. Levin (1981) suggests that quirky case is in fact lexical, and that verbs assigning such case are lexically marked to do so. It seems that (35) as a statement about the properties of verbs holds true, but with respect to structural and not lexical case. This being so, the connection between (35) and move-NP cannot be upheld because as we have seen, NPs assigned lexical case are frequently subject to move-NP, despite the fact that they are case-marked in their D-object position. All examples of movement, however, share an important property: they involve movement to subject position just in case the VP would otherwise lack a subject at S-structure. Both lexically and structurally case-marked NPs can be moved to [NP, S] position in order that the predicate-linking rule be satisfied.

It is consistent with this analysis that NPs may be moved as "far" as the locality conditions allows, and that when this happens

lexical case is preserved under movement, although structural case is assigned after movement and reflects S-structure configurational positions. Case-marking with structural case in (48) is the same as in the analagous English constructions:

(48) a. Þeir tálja { ad María (N) hafi skrifað ritgerðina.
 { María (ACC) hafa skrifað ritgerðina.

"They believe { that Mary has written her thesis."
 { Mary to have written her thesis."

b. María (N) er talin hafa skrifað ritgerðina.
 Mary is believed to have written her thesis.

In (49), the case-marking is lexical, and thus reflects D-structure configurational relations.

(49) a. Verkajanna (GEN) gaeti ekki.

"The pains are not noticeable."

b. Hann telur verkajanna (GEN) ekki gaeta.

"He believes the pains not to be noticeable."

c. Verkajanna (GEN) er talið ekki gaeta.

"The pains are believed not to be noticeable."

4.4.3 It has been suggested that the generalization that all case is structurally assigned is one that we wish to maintain, along with Burzio's generalization. If all case is structurally assigned, a more complex analysis of quirky case-marking must be presented. It is possible to argue that passive, in Icelandic, as well as in English, involves case-absorption, and movement to subject in these constructions, as well as in unaccusative verbs is because the [NP, VP] requires case. The fact that if an [NP, S] in a passive sentence is assigned quirky case, it is always the same case as that assigned to the [NP, VP] of the corresponding active form, is accounted for in terms of theta-chains. If a verb assigns quirky case it is thought of as requiring that it governs either an NP assigned that case, or a trace which is part of a theta-chain headed by an NP assigned that case. Thus in (45b), repeated here,

- (45) b. Steini-DAT_i var kastad t_i.
 "The stone was thrown."

the passive form kastad cannot assign dative case to its argument. However, it does govern a trace which is part of a chain headed by a dative-marked NP. The passive form var kastad is thus -T, -A as Burzio's generalization requires.

This analysis seems inferior to the one presented above on grounds of simplicity. However, in addition, there are other problems which an account in terms of government and theta-chains does not deal with.

In the first place, it does not explain how quirky case is assigned to the [NP, S] in, e.g. (45). If dative case is assigned to the [NP, S] position then we lose the principle that it is nominative case which INFL assigns. A more difficult problem is that there are languages where case is unequivocally lexical, and the alternative analysis presented for Icelandic cannot be made to work. Such a language is Basque. Basque has traditionally been analyzed as an ergative language in respect of case-marking. There is an ergative case NORK assigned to the subject of transitive verbs, and an absolutive NOR case assigned to the object of transitive verbs and the subject of single argument verbs. The auxiliary in transitive verbs is always UKAN, and it is marked for person, number and gender of both subject and object. In other cases the auxiliary is IZAN, and this is marked only with a NOR-marker indicating person, number and gender of its single argument. B. Levin (1982, 1983) has argued that Basque, while showing ergative case-marking, is in fact a nominative-accusative language. NOR is the equivalent of nominative case in English, and NORK the equivalent of accusative case. She argues that case-assignment reflects D-structure grammatical relations, and that NORK is assigned to the subject of intransitive verbs because this NP is thematically an internal argument, and D-object. This is claiming that all single argument verbs in Basque are unaccusative or passive. Levin argues that this claim is justified. Single argument verbs are semantically of the type classified by Perlmutter (1978) as unaccusative. Unergative verbs, which in English have a single external argument, in Basque take one of two forms.

They may be expressed by a V-NP pair, where the V is always the transitive verb egin "to make" and the NP may vary. Thus the unergative verb "to laugh" is barre egin, "laugh make", "to work" is lan egin, "work make", "to build" (a house) is extea egin "house make" and so on. The second option, which occurs with intransitive forms of transitive verbs like eat, is to maintain an object NOR marker on the verb, while deleting the object. Thus

(50) a. Jonek sagarra jaten du.

John-NORK apple-NOR eat 3s-NOR-UKAN-3s-NORK

"John ate the apple."

b. Jonek jaten du.

John-NORK eat 3s-NOR-UKAN-3s-NORK

"John ate."

The claim that Levin makes is that case reflects D-structure, and thus cannot be structural and assigned at S-structure. If case is not structural, it must be lexically assigned: external arguments are assigned NORK case as well as theta-roles, by their heads, and internal arguments are similarly assigned NOR case. Thus we have active-passive pairs like (51), where the internal argument has been

(51) a. Gizonak extea egiten du.

Man-NORK house-NOR make 3s-NOR-UKAN-3s-NORK

"The man is building the house."

b. Extea egiten da.

House-NOR make 3s-NOR-IZAN

"The house is being built."

assigned NOR case, and maintains it, even when it becomes the external argument at S-structure. (Note that Basque is a non-configurational language, so that move-NP has to be understood as "assume GF" (grammatical function) rather than in terms of movement). Given this analysis of passive, it is clear that move-NP cannot be explained in Basque in terms of Burzio's generalization. The D-object in (51b) becomes the subject, not because it requires case, but because the VP requires a subject at S-structure.

One might try to argue that in Basque case-assignment is not lexical but structural. NOR is then assigned to the [NP, VP] under government by the verb, and to the [NP, S] by the auxiliary IZAN, while NORK is assigned to [NP, S] by the auxiliary UKAN. The problems with this are twofold. In the first place, the generalization that case reflects D-structure grammatical relations is completely unexplained and becomes accidental. The second problem is not conceptual but empirical. Case assignment cannot be structural because it takes place within infinitivals, where there is no auxiliary to assign it.¹⁰ Infinitival clauses in Basque are always nominalized. The only way of saying "I want John to leave" is "I want John's leaving." Arguments of infinitival heads assign NOR and NORK case in the same way that inflected verbal heads do. The single argument of an unaccusative is assigned NOR case:

- (52) Jon joatea ona da.
 John-NOR go-NOMIN good 3s NORK-IZAN
 "The going of John is good."
 = "For John to go is good."

When the infinitival takes two arguments, NOR and NORK case is assigned again within the nominalized clause where there is no INFL node to assign case.

- (53) Mikelek eginkaria irakurtrea nahi dut.
 Mike-NORK newspaper-NOR read-NOMIN-NOR want 3s-NOR-UKAN-NORK 1s.
 "I want Mike's reading the newspaper."
 = "I want Mike to read the newspaper."

Here the infinitival assigns NORK case to Mike and NOR case to news-paper, and the whole clause is nominalized and receives NOR case from want. The matrix Aux reflects that want takes two arguments, a first person singular subject, marked NORK, and the nominalized want clause marked NOR.

Seeing that we are forced to say that in Basque case assignment is lexical, and that languages must thus allow the possibility of lexical case, it seems justifiable to assume the simplest analysis of Icelandic and to say that while assignment of nominative and accusative case is structural, quirky case is in fact lexical. This means that we can maintain Burzio's generalization with respect to structural case. However, there are sufficient examples of NP-movement where

the NP already has lexical case that we cannot explain movement as a mechanism to avoid violating the case filter. The analysis of move-NP as a mechanism to avoid violating the predicate-linking rule accounts for NP movement whether case-assignment is lexical or structural.

4.5 The analysis of predicate-linking which we have presented allows us to explain the second clause of the Extended Projection Principle (EPP) of Chomsky (1982), and in addition to explain the conceptual link between its two clauses. The first clause of the EPP is the Projection Principle, which requires that the theta-criterion be met at every syntactic level. The second clause is the requirement that clauses have subjects. This second clause expresses the principle defined by the phrase structure rule (54):

(54) S \rightarrow NP INFL VP

(although (54) also takes into account gerundives, which are not obviously clausal). It is claimed that most of the information conveyed by phrase structure rules can be captured by a combination of X-bar theory, theta-theory, and principles of case-assignment (cf., Stowell 1981), but (54) remains as a stipulation in the grammar. By including (54) and the Projection Principle together as the EPP, Chomsky makes the point that the two principles are conceptually quite closely related.

The fact that clauses have subjects is explained simply by the predicate-linking rule. According to this rule, all non-argument maximal projections require syntactic subjects, and the fact that an inflected VP requires a subject is just a particular instance of the more general principle. Every case covered by (54) is thus also covered by the rule of predicate-linking (although the converse is not true. (54) does not account, e.g., for small clauses). The difference between (54) and the predicate-linking rule is that the latter defines "subject" as "subject of a (particular) predicate", and not, as in (56), as the subject of a clause. If "subject" is understood this way, then "clause" or "S" can be defined as a particular type of subject-predicate relation, and not as a definiens of a recursive definition. The predicate-linking rule is required in any case, to account for the fact that non-clausal predicates require syntactic subjects, and by subsuming (54) under this rule we can remove a stipulation from the grammar.

The second clause of the EPP, in this account, is not that "clauses must have subjects," but that "predicates must have subjects" -- i.e., the predicate-linking rule. In the discussion in Chapter II we analyzed predicates as one-place functions, and the subject of a predicate as the argument which saturates that function. We also pointed out that lexical heads are a type of lexical function, and that by assigning theta-roles, they specify what thematic arguments they need in order to be saturated. Looked at in this light, the connection between the two clauses of the EPP becomes clear. A sentence can be represented in two different ways, in terms of lexical heads (or lexical functions)

and arguments, and in terms of predicates (or syntactic functions) and subjects. The former is represented at LF, and is "checked" by the theta-criterion, the latter is the S-structure representation, checked by the predicate-linking rule. The conceptual link between the two clauses of the EPP is just this; both clauses refer to the saturation of functions. We can rewrite the EPP as in (55):

(55) **Extended Projection Principle:**

For a sentence of L to be well-formed, both syntactic and lexical functions must be appropriately saturated: i.e., the Projection Principle and the Predicate-linking rule must be satisfied.

It is a result of defining subject as "subject of a predicate" instead of "subject of a clause" that clause (or S) becomes a definable concept, and not a primitive symbol on the left-hand side of a rewrite rule. In the next chapter we will define S as a particular type of subject-predicate relation which we will term primary predication, and distinguish between this and secondary predication. A second result of this definition of subject is that we explain why NPs do not have subject positions. The determiner position in a nominal may be filled by an NP, which, as we have argued, can never be properly assigned a theta-role, but this NP is never a "subject." Furthermore, pleonastics may never appear in this position:

- (56) a. *[Its belief that S]_{NP}
 b. *[Its rain]_{NP}

According to our definition of subject as "subject of a predicate" and our definition of predicate as a (non-argument) maximal projection, there can be no subject within the NP because there is no maximal projection for it to be the subject of. The internal structure of John's belief that S is (57):

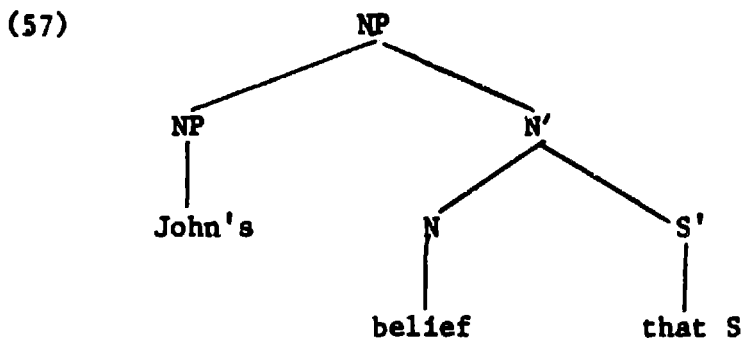

John's is the determiner of the NP, but not the subject of a predicate, for there is only an N', and not an NP, which it c-commands, and which c-commands it. Pleonastics would not be expected in this position. They are inserted by an S-structure rule (subject to conditions stated in 4.3) just in case the predicate-linking rule would otherwise be violated. The problem will not affect [NP, NP] positions, because the predicate-linking rule has no relevance within NPs.

It should be pointed out that Williams (1980, 1981) also defines the notion "subject" relative to a predicate. For him, the subject is the "external argument of a head." Despite the fact that this too defines subject relative to a predicate and not relative to a clause, his approach differs fundamentally from ours. For him, "subject" is defined in thematic terms: a particular thematic argument is

distinguished. For us, "subject" is defined in syntactic terms at S-structure, and the formal subject of a predicate can have no thematic relevance at all, for example, where it is a pleonastic. As we argued in Chapter III, it is no accident that the external thematic argument and the syntactic subject will coincide, but nonetheless, the two concepts must be kept distinct. There must be a formal subject even when there is no external thematic argument. In fact, this is exactly the point that the EPP is making.

4.6.1 So far we have discussed the move- α and cosuperscripting methods chiefly with regard to NP argument. However, as was pointed out in 4.3, S' arguments are also subject to the same processes. The examples cited earlier as (30), and repeated here as (58)

- (58) a. That John is tired is certain.
 b. It is certain that John is tired.
 c. John is certain to be tired.

all have the same D-structure representation (59),

- (59) is certain [that John $\left\{ \begin{array}{l} \text{to be} \\ \text{is} \end{array} \right.$ tired]

with the S' the sole, internal argument of the adjective certain. As (59) does not satisfy the predicate-linking rule, the structure has to be modified by one of three available methods. In the (a) sentence

the S' has been moved by move- α to the [NP, S] position. In the (c) sentence, the S' has been deleted, and the [NP, S] of the lower clause has been moved to [NP, S] position in the matrix clause. In the (b) sentence, a pleonastic has been inserted and cosuperscripted with the S', an option which is available despite the fact that move-AGR does not take place in the syntax in English, since an S' does not have to be assigned case. There are a series of circumstances in English which, on the surface, are identical to the example in (58b). These include

- (60) a. It is believed
 b. It was understood
 c. It amazed me
 d. It proved our point
 e. It was a problem
- } that John was tired.

Each of the predicates in (60) takes an internal S' argument and has D-structures analogous to (59). In (60), the method of pleonastic insertion has been used to provide a formal object at S-structure, but move- α could equally well have been used:

- (61) a. That John is tired
 b.
 c.
 d.
 e.
- } was believed,¹¹
 } was understood,
 } amazed me,
 } proved our point,
 } was a problem.

In addition, the (a) and (b) examples are S' deletion predicates, and

(62)

(62) John was believed to be tired.

John was understood to be tired.

is also acceptable.

There are, however, sentences similar in structure to (60), where the alternates in (61) are not available. These are the seem-type constructions:

(63) a. It seems that John is tired.

b. John seems to be tired.

c. *That John is tired seems.

(64) a. It appears that John is tired.

b. John appears to be tired.

c. *That John is tired appears.

We can see that seem and appear are both S' deletion verbs, and that the [NP, S] of the lower clause can be moved to the matrix subject position, but the S' itself cannot be moved, as (63c) and (64c) show. This is a problem for our analysis. It is an apparent counter-example to the claim that the preferable way of satisfying the predicate-linking rule is by externalizing an internal argument, and that

when a pleonastic *is* is inserted and cosubscripted with an argument, this argument is always one which could have been moved itself to subject position.

However, I should like to suggest that this is indeed only an apparent counter-example. The differences between the seem-type "raising" constructions, and those of (58)-(62) is the seem is not a lexical head and does not take any arguments at all. Rather, it is a form of the copula, and sentences like those in (63) all have to be analyzed as a type of copula construction. The implications of this proposed analysis are many, and a full discussion is beyond the scope of this dissertation. However, in the rest of this chapter I would like to outline the proposal a little more fully.

4.6.2 The most straightforward instances of copula construction are those using the simple "be". Examples are given in (65):

- (65) a. John is foolish/tired.
 b. John is a good cook.
 c. John is a less famous politician.
 d. John is out of his mind/in the garden.

In each of these sentences, the [NP, S] is a theta-marked argument NP, and the rest of the S is predicated of it. The be which is used in (65) is to be distinguished from the identificational or equative be (or be of identity), which takes two arguments, 'assigning each of them a theta-role, and identifying them as referring to the same object.

- (66) a. John is Mary's husband.
 b. The Evening Star is the Morning Star.
 c. The Dean is the Chairman of the Hospital Board.
 d. The noisiest ones are the freshmen.

Halliday (1967) describes several semantic tests for distinguishing between different forms of be, chief among which is the fact that the equated NPs in (66) can change places without this causing any differences in meaning (though there may be some change in focus)

- (67) a. Mary's husband is John.
 b. The Morning Star is the Evening Star.
 c. The Chairman of the Hospital Board is the Dean.
 d. The freshmen are the noisiest ones.

The examples in (67) have exactly the same structural descriptions as those in (66), whereas if a similar transposition were effected on (65) the output would be understood as topicalized constructions:

- (68) a. Foolish/tired is John.
 b. A good cook is John.
 c. A less famous politician is John.

(It is possible to read (c) as identificational, but note how much more forced this reading is than (69):

- (69) The less famous politician is John.

Clearly various factors, including that of definiteness are involved in determining when be is interpreted as identificational and when as a copula.)

The function of the copula be is very different. Itself, it assigns no theta-roles at all. In (65a) foclish, which is predicated of John, assigns the NP its theta-role. The copula does not designate arguments; the predicative adjective, nominal, or prepositional phrase does that by assigning a theta-role to its subject just as a VP does. The purpose of the copula is precisely and only to turn the predicate into an inflected predicate, just in case inflection is required by the syntax, but cannot be affixed onto the head of the XP. For the most part, INFL can be affixed onto V. Many verbal heads have a morphological "slot" for inflection and these heads can never appear in uninflected forms. (This has the consequence that, as adjunct predicates must always be uninflected, the language can never allow verbal adjuncts. This will be discussed more fully in Chap. V.) Where INFL cannot be affixed onto the verbal head, for example when the verb appears in participle form, an auxiliary copula must be used:

- (70) a. John and Mary were swimming.
 b. Bill's team has been defeated.
 c. Trois pommes ont été mangées.

The copula in (65) performs the same function. The predicates in these sentences are all "matrix" predicates and as such must be inflected. But non-verbal categories N, P, and A, cannot have INFL affixed, as verbs can, and the copula is required to express or "support" INFL. (An analogous process is "do" support. As (71) shows

- (71) a. John is tired. Is John tired?
 b. John left. Did John leave?
 c. You always leave early. Do you always leave early?

the process of question formation involves "subject-auxiliary" inversion. Where there is no copular auxiliary, but an inflected verb, (as in (b) and (c)), the inflected verb is separated into a form of do and "naked infinitive".)

The copula, then, is analyzed as an inflectional element which assigns no theta-roles, and takes no arguments. It is introduced solely to provide an inflectional element when the syntax requires it. It is a tense operator, and we may assume that at LF it is assigned scope, along with all other operators, and moved into COMP. (This is a proposal argued for in Stowell (1982).) The LF representation of (65a) would be

- (72) [is [John tired]_S]_S,

where tired is predicated directly of John, and is is assigned scope over the whole S. This implies that the correct way to look at the predicates in (65) is not as VPs but as inflected APs, NPs and PPs respectively. Note that we can also have inflected Ss, as in (73)

- (73) It is (it's) that John's tired.

(in answer to, e.g., What's the matter?). Here the S' is a predicate and, as it requires a formal subject, it is linked to the pleonastic it. The copula is is then inserted because INFL is required and the LF representation of (73) at LF is the simple assertion:

(74) Is [that John is tired].

4.6.3 Seem and other raising verbs are also to be understood as copulas, but with a somewhat different semantic force from the simple copula be. Many of the syntactic restrictions on be hold for seem also:

- (75) a. John $\left\{ \begin{array}{l} \text{is} \\ \text{seems} \end{array} \right.$ tired.
 b. John $\left\{ \begin{array}{l} \text{is} \\ \text{seems} \end{array} \right.$ a fool.
 c. It $\left\{ \begin{array}{l} \text{is} \\ \text{seems} \end{array} \right.$ that John is a fool.
 d. *That John is a fool $\left\{ \begin{array}{l} \text{is} \\ \text{seems} \end{array} \right.$.¹²

It is also the case that these copulas are all semantically related, with some kind of assertive force. The copula be is used with a predicate when that predicate is attributed unqualifiedly of its subject. "John is foolish" involves an unqualified assertion that foolish can be predicated of John. Seem has some of the same assertive force, but it is not an unequivocal assertion, but a qualified one.

"John seems foolish" is understood as "foolish can be predicated of John, uncertainly, not on good evidence." J. Austin discusses this in Sense and Sensibilia (ch. IV)¹³ and makes the point that this use of seems when we have "some, but not conclusive evidence carries with it the fact that 'seems' is compatible with 'may be' and 'may not be'." The other seem-type raising verbs, appear, turn out, look as if, all have similar semantic properties, and all share the syntactic properties described above.

This clearly explains why these lexical items appear to take no arguments. They are not, in fact, verbs, or any kind of lexical head which requires, and determines the nature of, specific thematic arguments. Rather, they are inflectional operators taking sentential scope.

The syntactic analysis of these copula constructions is analagous to that presented in 4.6.2.

- (76) a. [John [seems foolish]_{AP}]_S
 b. [John [seems a fool]_{NP}]_S
 c. [[seem [John tired
 a fool]] ;
 XP S S']

The predicates in (a) and (b) are analyzed as an inflected AP and an inflected NP respectively. While in the LF representation (c) seem has been moved by QR to COMP, and is assigned scope over the S. In (77) the analysis is basically the same:

- (77) a. [it seems [that John is a fool]_{S'}]_S
 b. [John seems [to be a fool]_S]_S

The S' in (77a) is an XP which is not an argument of any head. It therefore requires a formal subject, the pleonastic it. The copula is inserted because the predicate has to be inflected. In (77b) because of the S'-deletion properties of the operator, John can be moved from the embedded clause to the [NP, S] position to act as formal subject for the inflected S'. An interesting prediction made by analyzing copulas as operators and not as lexical heads is that, as there is no verbal form of the copula, there will be no derived nominals either. We expect that copulas will occur within gerunds:

- (78) a. John's seeming tired
 b. Mary's turning out a fool
 c. Bill's being out of his mind
- } upset us

This is to be predicted, given e.g. Reuland's 1983 analysis of gerunds as containing [+finite] inflection and AGR. If INFL is a requirement of gerundive nominals, then the adjectival nominal and prepositional heads in (78) will need an inflection marker in the same way that they would in a simple S. However, in non-gerundive nominals there is no INFL, and if a raising-"verb" is in fact a lexical realization of INFL we would not expect to find nominals derived from them. This

prediction is borne out -- there are no such nominals. We cannot use the forms seeming and turning out except in gerunds:

- (79) *The seemings
 *The turning outs

and appearing can only be used as an antonym of disappear

- (80) The constant appearing and disappearing delighted Ariel.

The only possible counter-example is appearance, as in John's appearance (the way he looked) upset us. But this is not derived from the copula either. Derived nominals all have the same argument structure as their corresponding verbal heads -- they are, after all, derived from the same lexical head. But while we have minimal pairs

- (81) a. He gave the book to the children.
 b. The gift of the book to the children.

it is impossible to use appearance with an adjective

- (82) a. John appeared tired.
 b. *John's appearance tired.

The only way (82b) can be interpreted as well formed is if appearance is understood again as the antonym of disappearance.

FOOTNOTES

- (1) In some languages, e.g. Chinese, there is no wh-movement at S-structure. However, as Huang (1980) argues, even in these languages there is wh-movement (and thus explicit scope-assignment) at LF.
- (2) Note that English has a mechanism for allowing resultatives with intransitives. An anaphor is inserted in [NP, VP] position, and becomes the subject of the resultative.
- (3) Impersonal passives may take prepositional arguments; in particular an agentive by phrase, as (10a) shows. However, these cannot be subjects for the VP. PPs like other maximal projections, have to be predicated of a subject, and as we argued in Chapter II, a subject cannot itself be predicated of its own subject. How PPs are linked to subjects is discussed in Chapter VI.
- (4) Virtual categories are discussed in Zubizarreta and Vergnaud, (1982).
- (5) It is also possible to move hier to the C_1 position, so that an alternate form of (14) is

(i) Hier wordt er veel geskeed

In some dialects of Dutch, (ii) is also acceptable

(ii) Hier_i wordt t_i veel geskeed

where the VP has been linked to the trace of hier. The analogous constructions in German are also fine

(iii) Hier_i wurde t_i den ganzen Abend getanzt.

A possible reason for the difference might be that in dialects where (ii) is not acceptable, VP must be linked to a nominal element, so er must be inserted in [NP, S] position, while S' can be linked to any [-INFL] element. In German, and the dialects of Dutch which accept (ii), VP as well as S' can be linked to hier. This may be another example of locative PPs behaving as closed arguments, which we noted in Chapter II.

- (6) Chomsky (1981) suggests that the cosuperscripting of [NP, S] and [AGR] takes place at D-structure, but there is no necessary reason why this should be the case. It is more plausible that it takes place at S-structure, firstly because cosuperscripting is to do with structural case-assignment, an S-structure phenomena, and, second, because there is no reason why there must be an [NP, S] position at D-structure. D-structure represents underlying grammatical relations, and if a verbal head does not have a D-structure subject, it is not clear why the representation must be as in (i)

(i) $[[e]_{NP} \text{ INFL VP}]_S$

It is possible that (ii) is more accurate

(ii) $[\text{INFL VP}]_S$.

- (7) It is clear there is a semantic difference between (30a-b) and (30c). In (a) and (b) the S' is the notional subject, of which certainty is predicated. In (30c) John is the notional subject, and what is predicated of this is is certain to be tired. However, this is a distinction which is to be made at SR, and which need not concern the syntax.
- (8) This predicts wrongly that the following sentences should be acceptable:

(i) *It was hoped [[PRO to go]

(ii) [[PRO to go] was hoped.

(pointed out to me by J. Higginbotham). This contrasts with the perfectly acceptable (and expected) (iii)

(iii) It was hoped that I would go.

At the moment I have no explanation for this.

- (9) (36b) and (37b) also predict the non-occurrence of structures like (i)

(i) It hurts him.

(where (i) is interpreted as "he hurst") where hurts is -T, but +A. Note, however, that (i) is ruled out independently by the constraints on pleonastic insertion and cosuperscription, discussed in 4.3. These constraints enforce, a cosuperscripting between [NP, S] (the pleonastic), AGR, and [NP VP], and entail that there be no clash in case-features among the co-superscripted elements. In (i) AGR and an accusative NP are cosuperscripted, and thus the sentence would be ruled out.

- (10) I thank Esmerlda Martin-Callijo-Menandise for this data.
- (11) It is clear that with some S' deletion verbs these constructions are dubious:
- i. It was thought that S.
 - ii. ?That S was thought.

But (ii) is not ill-formed -- the contrast between it and (63c) is apparent. Presumably some semantic considerations affect the acceptability of (ii).

- (12) Be, like seems, also has the property of deleting S' nodes which it governs. Cf. (Stowell (1978)). There are constructions analogous to (63b), e.g.,

- i. John is to be married.

but these have a specialized semantic force.

- (13) Sense and Sensibilia, J. L. Austin. ed. G.J. Warnock, OUP 1962.

CHAPTER V

5.0 Two types of predication relations are subsumed under the predicate-linking rule. These are the relations of primary and secondary predication. Primary predicates correspond roughly to what are called, on an intuitive level, "clausal predicates," while secondary predicates have been termed "small clauses." (Williams 1976, 1980, 1981, 1982; Schein 1982, etc.) Although both types are subject to the same syntactic conditions on well-formedness, each is characterized by certain particular syntactic properties. In this chapter, I describe some of these properties, and on the basis of this description define the notions in (1):

- (1) a. X is a primary predicate of Y under conditions $Z_1 \dots Z_n$
 b. X is a secondary predicate of Y under conditions $Z'_1 \dots Z'_n$

These conditions are all stated on LF. In addition, a further distinction can be made between the two types, since there are various semantic conditions on secondary predication which hold at SR, whilst primary predication is not subject to these.

5.1.1 The class of secondary predicates defines the syntactic class of adjuncts. Adjunct XPs are never theta-marked and are therefore never arguments and always require to be predicated of a subject. Adjuncts can be adjectival, prepositional or nominal, as the examples in (2) show:

- (2)
- a. John eats carrots raw.
 - b. They painted the house red.
 - c. He sprayed his new car a brilliant shade of green.
 - d. We elected John president.
 - e. We found Bill at last in the library.
 - f. We eat strawberries with cream and sugar.

(2a) we discussed briefly in Chapter II, terming it a depictive, while (2b)-(2d) are all instances of resultatives. It appears, however, that there are no verbal adjuncts.

- (3)
- a. *We like John run.
 - b. *We found Mary be in the library.

This systematic gap can be explained in the following way. As the examples in (2) show, adjunct predicates are always uninflected. Prepositional, adjectival and nominal heads are not morphologically inflected and therefore there is no problem with their being used as adjuncts. Verbs, unlike these other categories, have a morphological "slot" for inflection, and require an inflectional affix of some kind in order to be morphologically well-formed. A verb therefore cannot appear in adjunct position because in order to be well-formed morphologically it must be [+INFL], in which case, as an inflected predicate, it is ill-formed as an adjunct. Evidence as to the morphological difference between verbal and other types of heads, as we discussed in 4.5, comes

from the fact that when non-verbal heads require to be inflected, inflection can never be affixed onto the head itself but must be realized autonomously as the copula be. Thus we have

- (4) a. The carrots are raw.
 b. John is a fool.
 c. The best way to eat strawberries is with sugar and cream.

Note that the participle forms of the verbs also require a copula:

- (5) a. John is sleeping.
 b. The water is boiling.

We can hypothesize that this is because the -ing suffix here is not inflectional, but a purely "neutral" or formal suffix, which nonetheless completes the head (see Fabb (1982) for a full analysis of these forms). If this is the case, then we predict that these non-inflected verbal forms should be able to appear in adjunct position, and this is in fact true:

- (6) a. We found John at last, sleeping in the library.
 b. She likes to drink tea, boiling hot.¹

5.1.2 The characteristic which all these adjunct predicates share is that they are predicated of an argument which is theta-marked by another lexical head. In all of the examples in (2), the subject of the adjunct was the [NP, VP] of the matrix verb; carrots is assigned a "patient" argument by eat; as well as a theta-role by raw; the house is the object of painted and subject of (a brilliant shade of) red, etc.

In (2) all the subjects of adjuncts were within the VP, and thus internal arguments of the matrix verb, but it is of course possible to predicate adjuncts of the external argument of the verb:

(7) John wrecked the car, drunk.

Here, as we showed in 2.4, drunk must be an immediate daughter of the S node, because the subject and predicate must be in the relation of mutual c-command for the predication to be well-formed.

The well-formed adjunct predicates which satisfy both these structural and thematic conditions come in two varieties: those which are selected for by the verb, and those which are "free." We discussed, also in 2.4, the differences between resultative and depictive predicates and instances of each of these two varieties. Resultative predicates were permitted only with verbs which describe a change of state occurring to the patient argument. The predicate describes the state which the verb causes, and predicates this of the object. Here, we can see that it is the verb itself which "allows" or selects for a predicate of this type. These predicates are not of course

theta-marked, for they are not arguments. They are also not categorially specified. Usually a resultative is adjectival, but this need not be the case. There are nominal and prepositional resultative predicates.

- (8) a. We elected John president².
 b. He drank himself into a stupor.
 c. He painted the car a brilliant red.

This implies that within the lexicon, selectional demands are for semantically appropriate predicates, and are stated in category-neutral terms.

The second group of predicates, the "free" variety, is typified by the depictives. These appear with any kind of matrix predicate, but there are general semantic restrictions on how the predicate is to be interpreted. As was suggested earlier, a depictive describes the state of its subject at the time defined by the tense of the main predicate. Thus in (9):

- (9) Bill ate the carrots raw.

raw describes the state of the carrots at the time denoted by the tense of the verb eat. (9) might be paraphrased roughly as (10a), and more precisely as (10b):

- (10) a. Bill ate the carrots when they were raw
 b. [$\exists t: t$ a past time] Bill ate the carrots at t and the
 carrots were raw at t .

The formal paraphrase of such predicates is often more complex, especially when the main predicate describes a habit or disposition of its subject rather than a simple event. Thus

- (11) Bill eats carrots raw.

cannot be represented as simply as (10b) with reference to a particular point in time. The representation of (11) will depend on the tense representation given to the "habitual" present. Formally, the clauses of (11) are conjoined open sentences, an argument-place of each being filled by the object carrots, in a manner paraphrasable by (12):

- (12) Carrots are things x such that Bill eats x when (only
 when, provided that) x is raw.

The small-clause construction of (11) is thus seen to be semantically distinct from the relative construction of (13):

- (13) Bill eats carrots which are raw.

since the latter carries no conditional force.³

Depictive predications are distinguished by the specific semantic conditions which hold of subject and predicate. We have to distinguish between minimal pairs such as

- (14) a. John ate the peanuts salted/*salty.
 b. John ate the meat raw/burnt/*tasty.
 c. I met Mary drunk/in high spirits/*tall/*stupid.
 d. We eat carrots raw/*orange.

There seem to be two distinct conditions on these predicates. The attribute described by the predicate must be at the same time an intrinsic property of the subject, and a transitory one. Thus in (14a), salted is an acceptable predicate of peanuts, because it describes an intrinsic property of the subject itself, albeit a temporary property -- they do not grow salted. Salty, however, describes not a property of its subject, but rather the relation between the peanuts and John, (he finds them salty). A similar analysis accounts for (14b). This emphasis on the intrinsic nature of the property also accounts for minimal pairs like (15),

- (15) a. *We ate the meat fragrant.
 b. ?We ate the meat fragrant with herbs.

where the extra information in (15b) allows us to understand how fragrance can be an intrinsic property of meat. The examples in

(14c) and (14d) indicate that only temporary, intrinsic properties can be predicated in this way. Drunk and sick are both acceptable by this criterion, while stupid, tall and orange are not. Note that in the right context, i.e., when they can be interpreted as temporary, transitory properties, these are acceptable predicates, as (16) shows:

- (16) a. The rabbit met Alice tall.
 b. We don't eat tomatoes green, but we'll eat them red.

A third semantic constraint is stated in thematic terms: the subject of a depictive predicate must be an agent or patient, in particular NPs marked goal cannot take depictive predicates:

- (17) a. John gave Mary the book {drunk.
 {unread.
 b. *The nurse gave John the medicine sick.

In (17a) unread is predicated of the patient NP the book, but drunk can only be predicated of John. Despite the fact that configurational restrictions are met, Mary is the goal NP and cannot be subject of drunk. (17b) is anomalous for the same reason; John is the goal NP, therefore the only available subject is the nurse, and in the context of the sentence it is possible, but odd, to predicate sick of this NP. The same thematic restrictions hold within nominals; in (18) it is impossible to predicate sick

- (18) John's gift of the dog to Mary sick.

of Mary, and its subject must be the dog.

In summary, we have seen that secondary predicates must meet conditions on well-formedness at each level of the grammar. At S-structure they are constrained by the predicate-linking rule, at LF, where theta-relations are represented, they are constrained to be predicated of arguments theta-marked by another lexical head, and in addition, at SR they must meet specific semantic conditions. Before characterizing formally the relation of secondary predication, we will consider the characteristics of primary predicates.

5.2 Intuitively, primary predicates are "main clause" predicates. We can define instances of primary predication quite simply by saying that acceptable instances of predication which do not involve secondary predicates, do involve primary predicates. However, it is possible to give a more precise characterization of the properties of primary predicates. They occur in the following environments:

- (19) i. matrix sentences: [NP INFL XP]_S
- ii. dominated immediately by S': [[COMP] [S]]_S,
- e.g. a. [That [John is late]_S]_S, is disturbing.
- b. John persuaded him $\left\{ \begin{array}{l} [\emptyset \text{ [PRO to leave] }]_{S'} \\ [\text{that [he should leave] }]_{S'} \end{array} \right.$
- iii. perception and causative verb complements: [NP V [NP VP]_S]_S,
- e.g. a. I saw [John leave]_S.
- b. I made [John leave]_S.

iv. objects of S' deletion verbs: $[V [NP V (INFL) XP]_S]_{VP}$

e.g. I considered John (to be) a fool.

v. gerunds: $[[NPs [VP]_{NP}]_S]_{NP}$ ⁴

e.g. We disliked John's leaving.

All these examples of predication share certain features which distinguish them from adjunct predicates. The subject (if it is not a pleonastic) is, of course, theta-marked by the head of the XP predicated of it, but unlike subjects of adjuncts, this NP can never be the internal argument of any other lexical head. Williams (1982) defines the notion "argument complex" as "a head, its arguments and its arguments' arguments and etc." and in this language, we can say that each subject and predicate in (19) form an autonomous argument complex. This, of course, distinguishes them from the secondary predicate discussed above, which are constrained to choose as subjects, NPs assigned theta-roles from another source. It is clear in (i), (ii) and (v) that the subject is not the internal argument of another lexical head. Such theta-roles are assigned under government. In (i) there is nothing which governs the [NP, S], apart from INFL which does not assign theta-roles. In (ii) and (v) the [NP, S] is dominated not only by S, but by S' and NP respectively, and both these nodes are absolute barriers to government. The lexical heads persuade and dislike are "on the other side" of the barrier, and are therefore not able to assign a theta-role. However, the S' and the NP which each dominate the [NP, S] are governed by persuade and dislike, and are assigned a

theta-role by them. With (iii) and (iv) it is less obvious that subject and predicate form an autonomous unit because the [NP, S] is governed and case-marked by the matrix V. Perception verbs and causatives subcategorize for a "bare S," while consider and believe type verbs can delete the S' node which they govern leaving only an S between the matrix verb and the lower [NP, S] and [VP, S]. As S is not a maximal projection of any category, and thus is not a barrier to government, the matrix V governs, case-marks and is in a position to assign a theta-role to the NP adjacent to it. If it did so, then the instances of predication in (iii) and (iv) would be interpreted as adjunct predicates. There is evidence, at all levels of grammar (S-structure, LF and SR), that this is not the case. The syntactic evidence comes from the distribution of pleonastics. Adjunct predicates require their subjects to be theta-marked by another lexical head, and therefore they cannot be predicated of pleonastics, which by definition are not theta-marked. Yet the predicates in (iii) and (iv) can all have formal, pleonastic subjects, thus indicating that they are not adjuncts.

- (20) a. John watched it snow for hours.
 b. The witch doctor made it rain with magic.
 c. We believe it to have rained non-stop for 40 days.
 d. We consider it possible that it will snow.

The second piece of evidence comes from the assignment of theta-roles. Theta-roles are assigned to arguments, which are closed constituents. It is this which makes them denotative. In (iii) and (iv) the matrix verbs do assign a theta-role to an internal argument, but this argument is the whole S, and not the [NP, S] itself. We assume that the whole S is an argument of the verb because of minimal contrasts like the following:

- (21) a. We consider that John is foolish.
 b. { John to be foolish.
 c. { John foolish.

In (21a) it is clear that the S' is a closed, theta-marked argument of consider, and that John cannot receive a theta-role from anything other than is foolish. In (21b) where S' deletion has taken place, John functions in certain structural respects as the syntactic argument of consider, but the semantic interpretation of (21b) is the same as that of (21a), and the argument-assigning properties of consider are held to be the same in both instances. (21c) receives a similar semantic interpretation; and in all three instances consider is understood as taking a single, propositional argument. In the case of (22)

- (22) We saw Mary arrive.

there is no semantically equivalent S' complement ("We saw that Mary

arrived" has a very different range of possible interpretations, but evidence that Mary arrive is a thematic constituent comes from the close similarity between (22) and (23):

(23) We saw Mary's arrival.

Here the theta-marked argument of see is the NP Mary's arrival, and, as NP is an absolute barrier to government, Mary cannot be theta-marked or case-marked by see. The NP object in (23), and the S argument in (22) both denote a single item, the event of Mary's arriving, as Higginbotham (1981) argues. He further suggests that at some level of representation, (LF or SR), the S as well as the NP should be represented as a nominal differing only in the fact that the complement in (23) is definite, whereas in (22) it is indefinite. A similar analysis of the complement structure of causative verbs is proposed.⁵

The third reason to suppose that these predicates are not secondary predicates is that the semantic restrictions on adjuncts do not hold. Compare the examples in (24) with those of (14):

- (24) a. I consider John tall/stupid/a genius.
 b. We found the meat tasty/salty.

Here the non-temporary properties (24a) and the intrinsic properties (24b) can equally well be predicated of these subjects. It is true

that (25) is unacceptable, but Higginbotham (1981) argues that

(25) I saw John foolish/a fool.

this is because perception verb complements must denote events, not states; verbs which do not denote events are not permitted here either:

(26) *I saw John own a house/be tall.

When, in context, such complements can be understood as denoting events, they are acceptable:

- (27) a. I made John tall (by giving him a potion).
 b. I made John own a house (by leaving him one as a legacy).

Note that see does also take simple NP objects, as in "I saw John." These NP objects may of course be subjects of secondary predicates subject to the usual restrictions, hence we have the examples in (28):

(28) I saw John *tall/happy.

5.3 Given that the instances of predication in (19) can be shown not to have the properties of adjuncts it remains to state clearly how the distinction between the two types can be formalized. Adjuncts,

we saw, do not form constituents with their subjects, and thus a secondary predicate and its subject can never be a (theta-marked) argument. Adjunct predicates are never inflected, and there are semantic restrictions relating predicate and subject. Non-adjunct predicates do form constituents with their subjects, these constituents have a denotative function, and can refer to propositions, events, facts and so on. There were certain semantic constraints on these non-adjunct predicates, especially on the perception verb complements, but these were different from the constraints on depictives. The latter restricted the denotation of the XP alone -- it had to refer to a specific type of property, while the constraints on (19iii) involved the constituent as a whole -- the S had to denote a semantically appropriate object to the matrix verb, i.e., an event.

In stating a formal definition of the distinction between primary and secondary predication we do not want to make reference to these semantic differences, but rather to draw the distinction at either S-structure or LF. At S-structure, all predicates are subject to the same structural conditions, but they do meet different conditions at LF. We can formalize definitions of both primary and secondary predication, and state as a general condition on predication relations at LF that each instance of predication must meet the requirements of one or the other definitions. The essential property of secondary predicates is as in (29):

- (29) X is a secondary predicate of Y if and only if Y is an NP theta-marked by a lexical head other than X.

It is not possible to define primary predication as merely the converse of (29), i.e., the subject of a primary predicate is never an argument of another lexical head, because of examples like (30),

(30) John wrecked the car drunk.

where John is the subject of drunk as well as wrecked the car. In any case, as we have seen, primary and secondary predication are essentially different syntactically and semantically, and it is preferable to define each in terms of its properties, rather than defining one type in this way, and the second type as being "not the first." We can state the defining properties of an instance of primary predication as in (31):

(31) X is a primary predicate of Y if and only if X and Y form a constituent which is either theta-marked or [+INFL]

Despite the fact that primary and secondary predicates are not defined in terms of the same properties, the relationship between (29) and (31) can be stated clearly. The predicate-linking rule, a structural condition, is a necessary but not sufficient condition for an acceptable instance of predication. (32) is not, in

(32) *John foolish.

English, an acceptable predicate.⁶ (32) requires INFL to fulfil

the conditions set out in (31) to make it an acceptable sentence. Predicates do not require to be inflected in one of two cases. Firstly, a predicate and its subject can form a referential constituent, analogous semantically to a matrix S, which is a theta-marked argument of another lexical head, and is thus governed by an inflected head.⁷ An example of this is given in (33), where

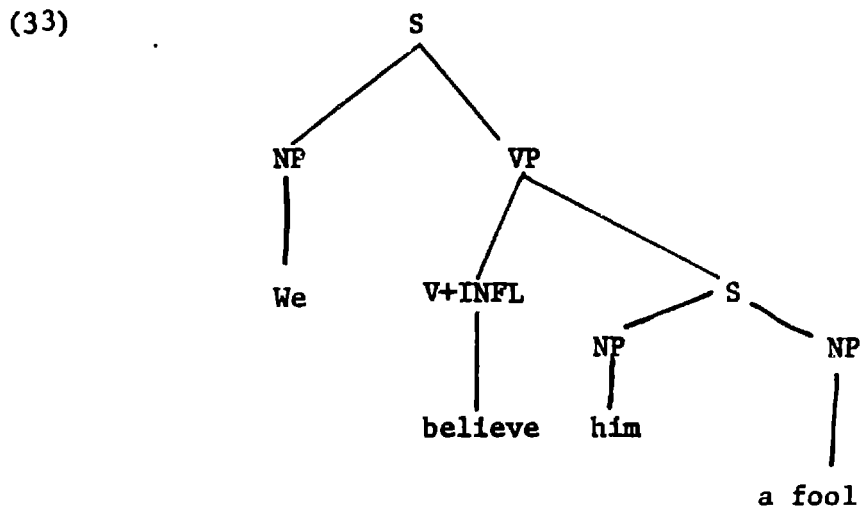

the S is an argument of believe (thus satisfying (31)), and so to speak "shares" in its INFL. In the second case, where the predicate is an adjunct, it must be predicated of an argument of an inflected predicate, and thus "shares" in INFL in this way. cf. (34):

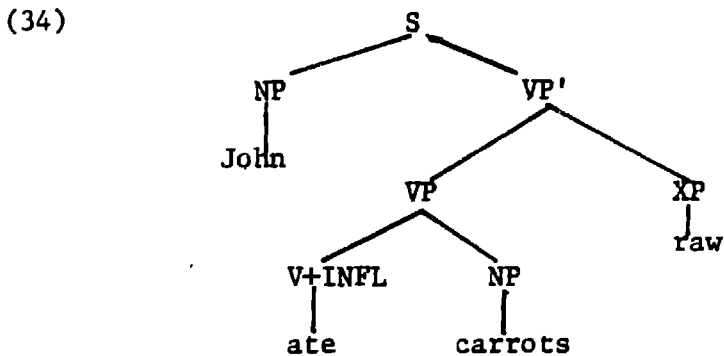

The general constraint on predication thus seems to be that any predicate must be dominated by INFL at some level. Instances of primary predication, which form referential constituents, are either arguments of an inflected head, or are directly inflected themselves. Instances of secondary predication consist of XPs predicated of an inflected head. This corresponds with the semantic distinction; that Ss are simple denotative units, while secondary predicates are "qualifications" of existing propositions.

The prediction of this analysis is that an S requires to be inflected only when it is not theta-marked, and for the most part this is the case. A matrix S can never be theta-marked, and thus is always inflected. The other type of inflected S is one immediately dominated by S' as in (35):

- (35) a. [That [John is late]_S]_{S'} is a shame
 b. John believed [that [he should go]_S]_{S'}

Here it is the S' which is the theta-marked argument, and the S itself, not an argument of an inflected head, requires inflection. We can thus explain the contrast between (36a) and (36b):

- (36) a. We believed [John happy]_S.....
 b. We persuaded Bill [[PRO happy]_S]_{S'}.

In (36a) the S is directly theta-marked by believe and thus does not require an INFL node, whereas in (36b) the S' is assigned a theta-role, and the S has neither theta-role nor inflection, and is thus an unacceptable case of predication. The inflected

(37) We persuaded Bill [[PRO to be happy]_S]_{S'},

is perfectly acceptable.

There are apparent contradictions to this generalization though. In the first case, the complement to S' deletion verbs are inflected and theta-marked:

(38) We believed [Bill to have gone]_S.

Here it is the S' complement that believes assigns a theta-role to, and the S which is immediately dominated by the S' must be inflected, in the same way as in (39).

(39) We believed [that [Bill had gone]_S]_{S'}.

A more serious problem for the claim that properties of having an INFL node and having a theta-role are in complementary distribution arises with gerunds and with perception verb complements ((19iii) and (19v)). Reuland (1983) argues that -ing is a form of INFL, and the fact that raising verbs appear in gerund forms supports this,⁸

as we discussed in 4.5. The verbal forms in perception verb complements also appear to be inflected, and this is supported by the fact that "naked infinitives" cannot be used as adjuncts. On the other hand, neither the +ing affix nor the (apparently zero) infinitival affix function as full inflectional markers; neither of them can be used in a matrix sentence (40)⁹

- (40) a. *John leave.
 b. *John leaving.

We suggest that these two affixes are not full inflectional markers and that this is why they appear to form theta-marked and inflected Ss. This correlates with the fact that perception verb and causative complements and also gerunds are distinguished from other instances of primary predication in semantic terms, and have been analyzed as denoting events rather than propositions. Furthermore, they have been described as having essentially nominal properties (Higginbotham (1981)), and this too marks them as different from the inflected Ss.

A final point to be made is that (29) and (31) alone are not quite sufficient because they do not together rule out (41):

- (41) *John foolish drunk.

According to (29) foolish and drunk are both secondary predicates of John, and thus (41) should be acceptable. It can be ruled out by

restating (29) as (42):

- (42) X is a secondary predicate of Y if and only if Y is an argument of another lexical head, and is dominated by S.

5.4 We can use the definition of primary and secondary predication given above to predict where XPs may occur.

- (43) *We eat carrots turnips raw.

is unacceptable because raw is predicated of turnips, but this NP is not theta-marked by another lexical head. Turnips raw must thus be an instance of primary predication and an uninflected S. However, if it is an uninflected S it must be theta-marked, and as there is nothing to assign it a theta-role, (43) is ruled out.

Conditions on secondary predication explain why several putative secondary predications are not well formed. We have already made reference to these, but will recap briefly. In the first place, a secondary predicate can never have a pleonastic subject

- (44) a. *It rains heavy.
b. *It snows freezing.

A secondary predicate has to have a subject theta-marked by another lexical head, and pleonastics, which are not theta-marked by anything,

are not acceptable subjects for them. (44) contrasts with (45):

(45) John arrived freezing.

where John is theta-marked by arrive, and is thus a possible subject of freezing.

We can also explain the facts about predicates within nominals. In (45b)

- (46) a. *The author of the book unread
 b. The delivery of the parcel unwrapped

the derived nominal assigns a theta-role to its object parcel, which can therefore be subject of the secondary predicate unwrapped. But the head of (46a) is a non-derived nominal which cannot assign a theta-role to its post nominal NPs. The NP the book, is therefore not theta-marked, and cannot be the subject of unread. This distinction between derived and non-derived nominals with respect to the possibility of assigning theta-roles explains the difference between (46a) and (46b). Similarly, this explains the contrast in (47):

- (47) a. *John's letter late
 b. ?John's performance drunk

In (47a) letter assigns no theta-role to the [NP, NP] and John cannot be the subject of late, whereas the derived head performance does have

a theta-role to assign and John's in (47b) can be interpreted as the subject of the secondary predicate drunk. As we argued in 3.3, the marginal status of (47b) is due to the fact that the theta-role cannot be "properly assigned" because there is no predication relation between the N' and the determiner, and the thematic relation cannot be syntactically encoded.

5.5 The analysis of secondary predicates which we have been developing violates the theta-criterion as presented in Chomsky (1981, 1982). The theta-criterion was stated in Chapter III (13), and is repeated here as (48):

- (48) i. Every obligatory theta-role must be assigned to one and only one argument
- ii. Every argument must be assigned one and only theta-role.

(48(i)) presents no problems. It says in effect that a lexical head is a function with n argument places, and each of these places must be filled by one argument and no more than one argument. The second clause states that an argument can be assigned no more than one theta-role. Our analysis of secondary predication has made it a condition on secondary predicates that the subject of such a predicate is the argument of, i.e., is assigned a theta-role by another lexical head. It is therefore a condition on secondary predication that the theta-criterion be violated. The analysis of small clauses in Chomsky (1981) conforms to the biuniqueness requirement of (48(ii)). As a result

(49a) is analyzed as (49b):

- (49) a. John left Mary angry.
 b. [John [left Mary]_{VP} [PRO angry]_S]_S.

Here the adjunct angry assigns its theta-role to PRO. PRO can then be controlled by Mary or by John, depending on which interpretation of (49a) is required. There are several weaknesses in this approach to small clauses. Firstly, in order for PRO in (49b) to be ungoverned, the constituent [PRO angry] must be outside the VP. This means that the ambiguity of (49a) is not structurally represented, as they are in the analysis of small clauses presented in this dissertation. A second problem is semantic. The semantic representation of (49a) where angry is predicated of Mary interprets the sentence as a single complex predication, with left Mary angry predicated of the subject John. Where this predication is not dominated by a single VP node, the algorithm proposed in 3.2 for mapping between LF and SR no longer works. It is not the case in (49b) that the syntactic predicate directly correlates with the semantic predicate. Thirdly, we have claimed that every instance of primary predication is a referential constituent which must be either inflected, or assigned a theta-role. [PRO angry] is neither of these, and directly contradicts our analysis of the properties of Ss. Furthermore, if we analyze adjuncts as we are forced by (48(i1)), then every adjunct can be represented with a PRO subject as a constituent S in a non-theta-marked position. We are then not able to predict where such Ss can occur, and cannot rule out (43). We

lose the syntactic generalization that S constituents are either theta-marked or inflected, and we lose the semantic generalization that S is a referential constituent denoting an autonomous unit (usually a proposition, or as with (19(iii)) and (v) an event).

Schein (1982b) presents an analysis of small clauses in which he suggests weakening the theta-criterion to (50):

- (50) i. Each theta-role is assigned to one and only one argument.
 ii. Each argument bears a theta-role.

(50) allows the analysis of adjuncts presented here, but is not sufficient to rule out other, unacceptable violations of the biuniqueness condition, ruled out by (48(ii)):

- (51) a. The book_i gave t_i.
 b. We thought John_i proud t_i

In (51a) the book is the patient argument of gave, which has been moved to [NP, S] position, because the sentence was generated without an external argument. Here it is also assigned the agent role. Similarly, John in (51b) is both the subject of proud and as the trace indicates, the internal argument of the AP. It is possible to suggest that (51a) is ruled out because the NP is assigned nominative case, while the trace is assigned objective case. However, this does not account for (51b) where proud assigns no case at all. ("of"-insertion operates between an adjective or noun, and an adjacent lexical NP, and presumably

would not apply in (51b)). Clearly an addition to (50) is required. Schein himself suggest the condition is an earlier piece of work (1982a), and discusses it in footnote 16 to (1982b). He proposes

- (52) Any two theta-roles θ_1 and θ_2 cannot be assigned to the same NP if and only if the α that selects θ_1 also selects θ_2 .

which has the effect of making (51) unacceptable.¹⁰

FOOTNOTES

- (1) Note that the so-called "naked" infinitives cannot appear as adjuncts. They do appear in the complements to perception verbs and causatives:

- (i) We saw John drive away
 (ii) We made Mary leave early.

We will show in 5.2 that these complements are clausal, and thus take inflected predicates. These infinitivals then may be used where an inflected predicate can appear, but never where the predicate must be uninflected. We hypothesize that despite the term sometimes applied they are not "uninflected infinitives", whatever their precise status may be.

- (2) These are to be distinguished from the genuine ditransitive verbs which select, and theta-mark two thematic arguments, e.g.

- (i) They called him insulting names.
 (ii) He envied him his new car.

- (3) It has been suggested (Halliday 1967, Simpson 1982) that the predicate in (11) can be interpreted in one of two ways, either as a depictive or as a circumstantial or conditional. They illustrate this with

- (i) The books sell cheap

which can be interpreted as the depictive (ii) or the conditional (iii).

- (ii) The books sell at a cheap price
 (iii) The books sell only when they are cheap.

However, there are no syntactic distinctions distinguishing them in the same way that depictives and resultatives are distinguished. The differences between (13a) and (13b) and between (ii) and (iii) must be the responsibility of the semantic interpretation.

- (4) For a structural analysis of gerunds see, e.g., Chomsky (1979), Schacter (1976). The exact structure of *v* is disputed; what is clear is that (*v*) consists of an NP with a VP in place of the *N'*.

(5) Despite the fact that the complement of make

(i) I made Mary leave.

(ii) He made John build a house.

can be understood as denoting an event, more has to be said to explain the ungrammaticality of

(i) *I made Mary's arrival.

(6) In some languages, e.g., Hebrew, structures analagous to (32) are acceptable, and are usually analyzed as having a null copula.

(7) Assuming that affix-hopping in English takes place at PR, then at S-structure (33) will look like this:

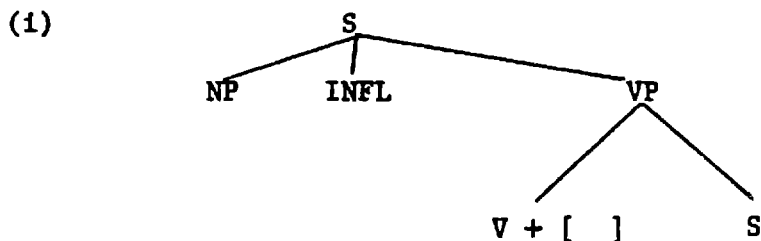

so that the S is governed by a to-be-inflected head. If we assume that INFL is in any case moved at LF to COMP, then the structure of (33) at LF will be

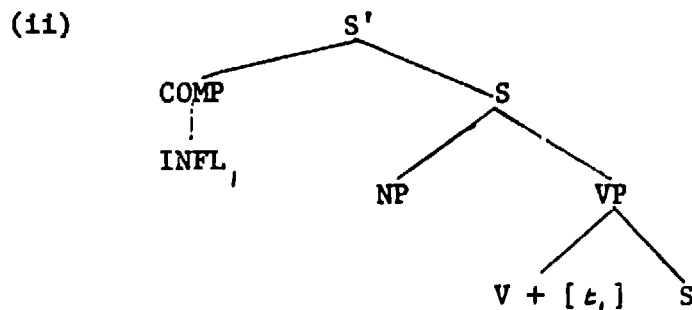

and the syntactic representation of AGR will be irrelevant. The INFL node in (ii) will bind the variable $[+INFL]$ slot in the V. (see Chapter VI).

- (8) Fabb (1982) suggest that there is both a verbal and a nominal +ing affix. While the verbal participle is used in gerunds, it is the other which occurs in the adjectival small clauses, e.g., He left the room, shouting.
- (9) The naked infinitive is acceptable if INFL is expressed by do e.g.

(i) Did John leave,

whereas it cannot occur with the copula in (ii), implying that its status is different from that of the inflectional categories.

(ii) *John is leave.

Presumably (iii) is acceptable because the +ing affix here is

(iii) John is leaving

not the verbal affix, and leaving can be interpreted as an AP.

- (10) This is basically the same to Williams (1983) version of the theta-criterion. He states

(i) In an argument complex each phrase is assigned only one theta-role.

where "argument-complex" is

(ii) ... a verb (or any other predicate) its arguments, its arguments' arguments, and so forth.

However, he puts this to a different use.

CHAPTER VI

6.0 In this chapter we will examine the characteristics of those constituents which can be theta-marked arguments of lexical heads. The constituents which can behave this way are the maximal projections NP and S', and, as we saw in the previous chapter, certain Ss. Several questions immediately arise. As the predicate-linking rule states, all maximal projections which are not theta-marked have to be predicated of a formal subject at S-structure. This raises the question of what the connection is between theta-marking (or the lack of it), and predication, and why it is that S' and NP are the only maximal projections that can be theta-marked. We must also ask what the difference is between argument and non-argument NPs and Ss, and also between theta-marked and non-theta-marked Ss.

The answers lie in the fact that theta-roles indicate the referential positions in a sentence. This is not to say that every theta-marked constituent denotes some real-world object, but rather that any theta-marked constituent must be structurally a referring expression. The structural property which makes this possible is that, unlike predicative XPs, these constituents are not open functions, depending on another constituent for completion, but are closed autonomous units. They therefore are not linked by the predicate-linking rule, but are the constituents to which other predicative XPs may be linked for closure. Such closed syntactic units appear only as arguments of lexical heads. Lexical heads can be seen as defining relations

between arguments.¹ See, for example, defines the two-place relation involving John and Mary in

(1) John saw Mary.

The theta-roles assigned by a head indicate how many arguments are involved in the relation and what the semantic role of each argument is. The theta-criterion, by specifying that each argument be assigned a theta-role, ensures that an argument can appear in a sentence only if it is involved in such a relation.

Theta-marked constituents are exempt from the predicate-linking rule because they are not dependent on external arguments for closure. They are thus also the potential subjects for predicates. This follows from axiom (13) (cf. Chapter II) which states that if X is predicated of Y, then Y may not be predicated of anything. Y must therefore be a theta-marked, internally closed constituent.

S' and NP are the only maximal projections which can be theta-marked² because they are the only XPs which can be closed without linking to an external argument. Similarly, Ss which can be theta-marked are closed, as opposed to other open forms of S, which would be unacceptable in a theta-position. The question we will discuss in this chapter is what are the structural properties of these constituents which makes it possible for them to be internally closed. The answer seems to lie, as regards to nominals, in the analysis of NPs as restricted quantifiers. With respect to S' and S, the property

of being open or closed involves factors of tense and inflection. A full study of either of these areas is beyond the scope of this dissertation. This chapter should therefore be read as the beginning of an analysis of the syntactic structure of arguments, and as making certain suggestions for further research.

6.1.1 NPs can appear either in theta-positions (2a), in which case they must be closed arguments, or in non-theta-positions (2b), in which case they must be properly linked, according to the predicate-linking rule.

- (2) a. A fool walked into the room.
 b. We considered John a fool.

If we are to follow the basic tenets of X-bar theory and assume that all NPs are XP projections of an N° head, then it will follow that predicative and argument NPs should have the same internal syntactic structure. We then have to ask how it is that NPs can sometimes be closed, and sometimes open.

The structure of NP is as in (3) (following Jackendoff (1977), Chomsky (1981), and etc.)

- (3) [Det [N']]_{NP}

where Det is a determiner -- either a, or the, or else a quantifier like some, every, many, or a full NP which receives possessive case,

e.g. John and the man in John's cat, the man's belief that S. It has been suggested (originally in Rescher (1962), and discussed later in e.g. Barwise and Cooper (1981)), that NPs are really quantifiers, and that (3) reflects their quantificational structure. Barwise and Cooper give the following structural analysis:

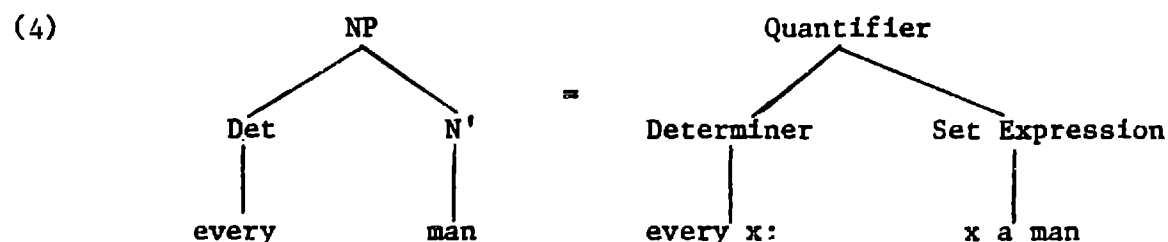

where the determiner is seen as binding a variable in the N'. Higginbotham (1983b) understands the structure of an NP in this way; NPs are thus to be seen as restricted quantifiers, with the N' analogous to an open sentence. Comparing the structures in (4) to (5),

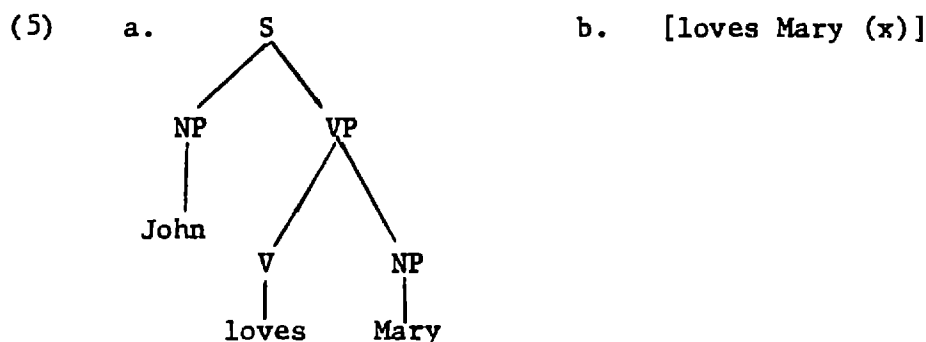

we can see immediately why VP must always be a predicate, linked to an external argument, whereas this is not the case with NPs. In (5), it is the maximal VP which immediately contains a variable.

As there is nothing to bind the variable within the maximal projection, the VP must remain open, and can only be closed by linking to an external argument. In (4), on the other hand, it is the N' which immediately dominates the variable. The determiner is thus available to bind it, and when this is the case, the NP is "internally" closed. Any determiner, and not merely an overt quantifier, can bind the variable in the N'. However, pleonastics may not appear in this position, hence (6):

(6) *its rain.

This is predicted by the analysis of pleonastic elements in Chapter IV, which said that pleonastics are inserted by an S-structure rule, when a maximal projection with no external thematic arguments requires a subject to be predicated of. It will never appear unless a full predicate is linked to it. Thus it will never be the determiner of an NP because the NP does not properly contain an XP which requires a subject,³ but only an N'. Higginbotham (1983b) proposes a different reason for the non-occurrence of pleonastics in this position. He asserts that the ordinary rule for interpreting the relation between determiner and N' in NPs like the cat is rule (7):

(7) [the x: cat(x)].

However, when the determiner has lexical content, as is the case in NPs like John's cat, an additional rule of interpretation is required.

Not only does the determiner John's bind the variable in the N', but there is a specific semantic relation between the [NP, NP] and the N'. The semantic structure assigned to such NPs is (8):

(8) [the x: cat (x) and R (John, x)]

Here, the binding properties of the determiner are represented, but in addition there is a relation R between John and the variable, to be interpreted contextually. As we discussed in Chapters III and V, the usual way of assigning a semantic relation between head and argument is by interpreting the latter as a theta-marked argument of the former. This is not available for [NP, NP] because none of the syntactic methods of encoding theta-relations can apply here and the theta-role cannot be properly assigned (cf. 3.3). The [NP, NP] cannot be assigned case by the head, neither can it be interpreted as the external argument of the head because there is no maximal projection intervening between them. Thus the need for the contextually interpreted relation. Higginbotham suggests that this semantic relation between the two positions is the reason why pleonastics cannot fill the [NP, NP]. A pleonastic is not a simple determiner, so rule (7) is not sufficient. Yet because it is a purely formal syntactic element, rule (8) cannot apply either. Pleonastics are unable to take part in a semantic relation like R. They are ignored at the levels of semantic interpretation, so that when R is interpreted it will be passed over, and R will be analyzed as an incomplete relation, lacking an argument.

In fact these two explanations are complementary. Both the impossibility of pleonastics in [NP, NP] position, and the necessity for a contextually interpreted relation between [NP, NP] and N' are the result of the same syntactic fact -- that there is no predication relation between determiner and N'. Pleonastics are inserted by a syntactic rule, only to provide a formal subject for an unlinked non-argument XP. In the same syntactic context the general rule for interpreting the semantic relation between a head and its external argument applies. The general rule involves interpreting R, the semantic relation between head and subject, with reference to the theta-role assigned to the subject by the head. c.f. (9).

(9) $R(\text{NP}, x) \rightarrow$ NP is subject of the maximal projection of x, and
NP is assigned a thematic role by x.

It is only when (9) does not apply that the relation between the NP and the lexical head must be interpreted contextually. This will occur in exactly those places where the rule of pleonastic insertion will not apply either.

6.1.2 Not all NPs act as theta-marked arguments. NPs may appear as primary predicates:

(10) We considered John a fool.

as predicates selected by lexical heads (nominal or verbal):

- (11) a. We painted the house a brilliant shade of red.
 b. The house was painted a brilliant shade of red.
 c. The painting of the house a brilliant red upset us.

and as free adjuncts:

- (12) a. John left school, a good-for-nothing dropout.
 b. Mary, a dancer, joined the Royal Ballet.

The underlined NPs in these sentences are clearly not theta-marked arguments, but are predicative XPs linked to a formal subject in the appropriate syntactic context. It seems that in these cases the determiner which binds the variable in the N' does not close the NP, but leaves it as an open function which can be predicated of a subject. However, while all the NPs in (10) - (12) are acceptable as predicates, the examples in (12) are not:

- (13) a. *We consider the boys several/many idiots.
 b. *The boys, several fools, failed the exam.
 c. *They believed the men a few soldiers.

Whatever factor allows the NPs in (10) - (12) to be predicates does not permit the same for the underlined NPs in (13).

A possible explanation for these facts is the following. The determiners in (12) are all quantifiers: several, many, a few. These

quantifiers bind the variables in the N', and close the NPs of which they are determiners. Those quantificational NPs (which are subject at LF to the rule of quantifier-raising) are always closed, and thus are never predicates. They require no external argument to close them, and the constructions in (13) are ill-formed because NPs with the structure of arguments are being used as predicates (and, in addition, lack theta-roles, thus violating the theta-criterion). Other determiners have a much weaker quantificational force, and although they do bind the N' variable so that it is not "free in NP", they do not close the NP. The determiner, a, of a fool in (10), works in this way. It binds the variable in the N' within the NP, but it does not close the NP. The representation of a fool is

(14) [(x) a fool]_{NP}

analogous to the VP representation in (5b). However, the determiner a may close an NP and allow it to be an argument. We have examples like (16) as well as (15):

- (15) a. We consider him a good doctor.
 b. John, a good doctor, came round to help.

- (16) a. A good doctor joined the clinic.
 b. Finally we found a good doctor.

It appears that what happens with a is the converse of what happens in the case of the true quantifiers. In (13) the true quantifiers prevented the NPs from being anything other than arguments. In (15), where there is a formal subject available, and where the NP is in a non-theta position, the NP is interpreted as a predicate. But where the predicative interpretation is not available, a can bind the variable in the N' and the NP can be understood as an argument.

The determiner the also allows its NPs to be predicates or arguments, but it has a stronger quantificational force than a. (Note that it is sometimes assigned scope by the move-quantifier rule (QR) at LF, while a is never subject to this rule.) It is therefore much less easily interpretable in predicative position than a.⁴ The possibility of interpreting the x as a predicate depends in part on contextual features -- including the lexical material covered by x. Thus in (17)

- (17) a. ??We consider John the man.
 b. ?We consider John the best man.
 c. We consider John the best man for the job.

the (a) sentence is difficult to interpret. As the N' contains more and more evaluative material, the easier it is to interpret the NP as predicative. For some reason, an NP is easier to interpret predicatively if it is a comparative or superlative. For example

- (18) a. We consider John { ?the good doctor
 b. } the better doctor
 c. } the best doctor

These distinctions between the possibilities of interpreting various NPs as closed or open show up clearly when the matrix verb is ambiguous. The verb find has two complement structures. Either it is analogous to consider, and takes an S complement, to which it assigns the theta-role "proposition." An example of this would be "We found [the book boring]_S", with the AP boring predicated of the [NP, S] the book. On the other hand, find may assign two theta-roles, a patient and a benefactive, and it can have an [_NP PP] or an [_NP NP] complement structure. Examples of this are "We found the book for John," and "We found John the book." In the examples in (19) the underlined NPs force a particular reading of find, by their internal structure.

- (19) a. We found them many good doctors.
 b. We found them the good doctors.
 c. We found them good doctors.

In (19a) the NP many good doctors cannot be understood as a predicate because it is closed. It can only be an argument, which means that, if the sentence is to be well-formed, find must be interpreted as assigning theta-roles to both them and many good doctors. And indeed,

(19a) has only the reading "We found many good doctors for them." The predicative reading "We found them to be many good doctors" is unacceptable. In (19b), the has a weaker quantificational force than many and the two readings "We found the good doctors for them," and "We found them to be the good doctors" are both available. However, the first reading, where the good doctors is interpreted as an argument, is still preferred. In (19c), there is a null determiner which is the plural form of a. It is not a quantifier, and closes NPs only when there is no subject for the NP to be predicated of. Strictly speaking, the NP "good doctors" can be interpreted as a predicate or an argument, and both readings of (19c) are available. However, the predicative reading "We found them to be good doctors" is the most easily available, which is what we would predict.

6.1.3 A problem mentioned briefly in Chapter II involves prenominal APs such as tall in the tall man. It would seem likely that these adjectives, like other maximal projections, are functions which require linking, but there is no NP in the correct syntactic position for them to be linked to. The structure which these phrases are to be assigned is given in (20):

(20) a. [the[[strange]_{AP} [man of la Mancha]_{N'}]_{N''}]_{NP}

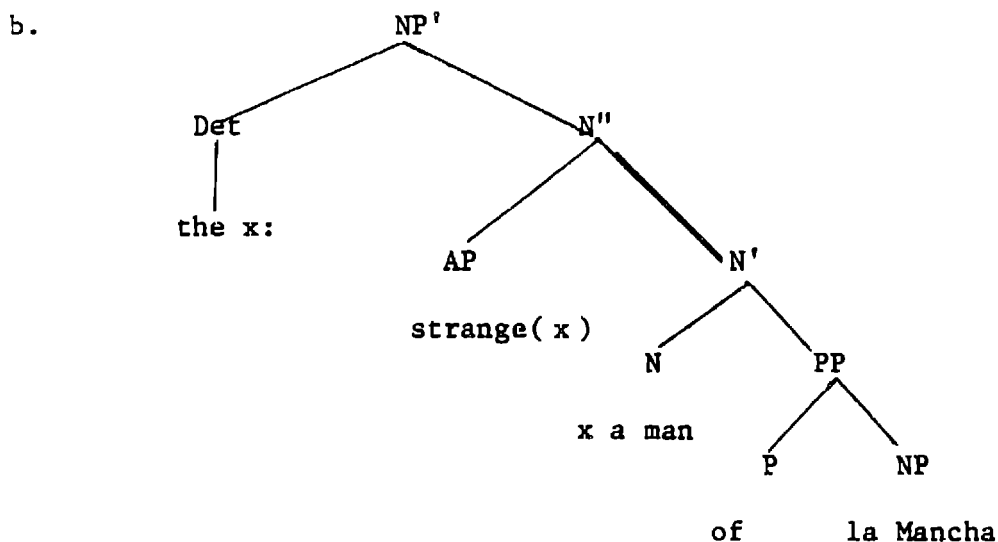

The determiner in (20) is in a position to bind the variable in the AP as well as that in the N'. The AP is thus saturated, though not by the predicate-linking rule. As it is bound within the NP it is already closed. The predicate-linking rule is blind to it because it is part of the NP, and it simply has no empty slot to fill with an argument. Semantically it is interpreted not as an autonomous predicate with its own subject, but as part of the complex "open sentence" x a strange man of la Mancha. Note that in English only prenominal NPs can be bound in this way. This may be because in (20) the AP is not part of the N' but sister to it, and both can thus be bound by the determiner. In, e.g., the man tall, the structure would be

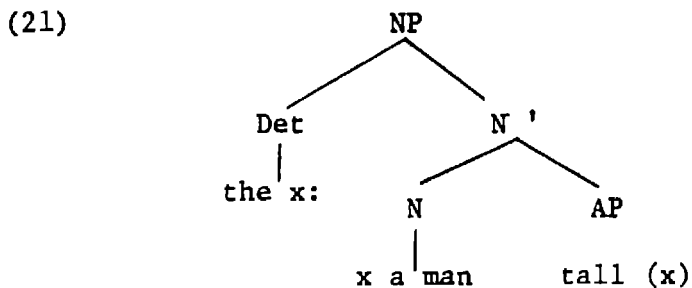

Here the AP is within the N' and cannot be linked either to the determiner or to any NP within the N'.⁵ Post-nominal APs are acceptable only when there is an NP within the N' which the AP can be predicated of, e.g., the delivery of the parcel unwrapped, where unwrapped is predicated of the book. Presumably in languages which allow post-nominal APs to be bound by the determiner, e.g., the French le crayon bleu, a structure like (22) is available:

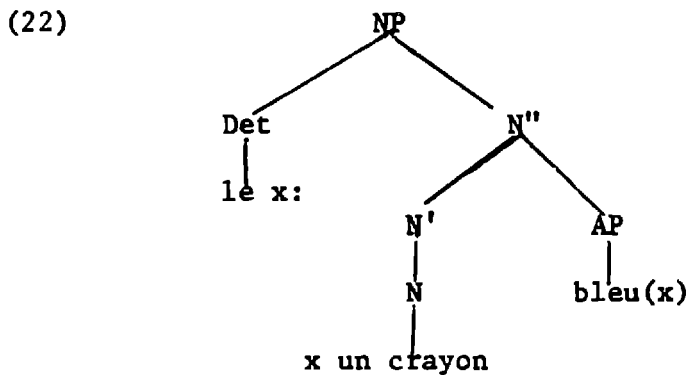

6.2.0 The second type of XP which can be either an argument or a predicate is the S'. We have examples of S's in both these positions:

- (23)
- a. We told John [that he should leave]_{S'}.
 - b. We told John [because we wanted him to leave]_{S'}.
 - c. We know [who had won the race]_{S'}.
 - d. We wanted to meet the man [who had won the race]_{S'}.

In (23a) and (23c) the S' is a theta-marked argument of the matrix verb. In (23b) and (23d) the S' is not theta-marked, but is linked

by the predicate-linking rule. (In (23b) there is no NP for the S' to be linked to. In 6.3 I shall suggest that, like certain PPs, the S' can be linked to INFL.) I shall argue in this section that the paradigms in (23) are explained by the fact that S' has a structure analogous to that of NPs, with a "determiner" binding a variable. The "determiner" position in S' is COMP, but the analysis of S' is complicated by the fact that COMP is "doubly-filled", dominating a wh-node and an INFL node (cf. J. Levin (1983)), and that furthermore INFL seems to involve both tense, and a nominal element. We will first look at wh-sentences, and then go on to discuss tense and INFL.

6.2.1 The wh-element in COMP works very similarly to the determiner in NP. It has some properties of a quantifier -- e.g., it is assigned scope by QR at LF, and it must bind a variable within the S governed by COMP. This variable may be either a trace, as in (24a), or a resumptive pronoun, in (24b) (from Hebrew).

- (24) a. The man₁[whom [I saw t₁]_S]_S,
 b. ha-ish₁[se-[ra'iti oto]_S]_S,
 The man that saw-I him
 "The man whom I saw."

The wh-element shares another property with determiners. When it binds the variable in S within the S', it may either close the S', in which case the XP is an argument (23c), or it acts as a "gate", allowing the S' to be predicated of an NP in the appropriate

syntactic position ((23d), (24)). In (25)

(25) I recognized [the man [who₁ we met t₁ yesterday]_{S'}]_{NP}

the wh-word who binds the trace within the S', but instead of its closing the S', the whole XP is left open and predicated of the NP the man. The structure of the sentence is as in (26):

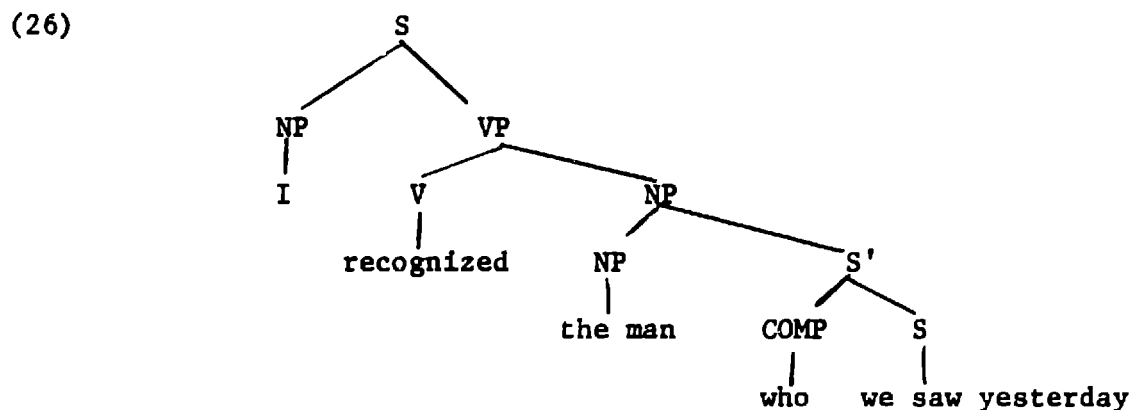

6.2.2 Clearly this is not all which must be said about the structure of Ss. In the first place there are Ss which are closed which have no wh-element; for example (27):

- (27) a. We persuaded John [(that) he should leave]_S,
 b. [That he should leave] is obvious.

In the second place there are sentences which are closed as far as wh-words are concerned, but which are not arguments. These are the matrix sentences like (28):

(28) [who₁[did he see t₁]_S]_{S'}

Not only is (28) not an argument (there is nothing for it to be an argument of), but it is not possible for clauses which are marked [+tense] to appear in argument position.

- (29) a. *We persuaded John he leaves⁶
 b. *He leaves is obvious.

This relates back to the point made in Chapter V that theta-marked Ss are those Ss which are not inflected. Let us rephrase this as the claim that Ss which are [+tense] are not theta-marked, and conversely, clauses which are theta-marked are [-tense].

(We follow Stowell (1982) in analyzing infinitivals like "We believed John to be a genius" as having "unrealized tense".⁷ Given these facts about the distribution of S clauses we hypothesize that it is having the feature [+tense] which makes a clause open, and that this is why tensed clauses are not permitted to be theta-marked, i.e., to appear in argument position. We may think of tense as quantifying over time. The (partial) semantic representation of a sentence like (30a) is as in (30b):

- (30) a. John saw Mary.
 b. [∃t: t a time] John saw Mary at t and t is PAST.

Stowell (1982) suggests that tense is represented at LF in COMP. In 4.5 we discussed this in reference to the LF representations of copula sentences. The LF representation of (30) is hypothesized to be (31):

(31) [PAST [John saw Mary]]_{S'}

with tense represented as an operator assigned scope.

If inflected Ss are open sentences, then the relation between a non-argument S and an argument S' is that S' is a closed S. We hypothesize that complementizers which are not +wh-, are in fact [+tense] and are capable of binding the tense-operator in S, and closing the clause. (Thiersch p.c. and den Besten (1978) both argue that complementizers and verbs share a +inflectional element. Evidence for this is that only these two constituents may fill the V₂ place in a sentence, cf. 4.2.). In (32)

(32) We knew that John saw Mary.

the tense-operator in the embedded clause is bound by that, and the whole clause is closed and can be the thematic argument of knew. The semantic correlation of this distinction between open Ss and closed Ss is that while (31) is understood as referring to an event in "real time", the S' in (32) denotes a proposition, and the semantic paraphrase of (32) is roughly "We knew the fact that John saw Mary."

Several facts are explained by this analysis. In the first place we can explain why Ss which are not tensed do appear in argument positions. The embedded Ss in (33)

- (33) a. We consider [John a fool]_S .
 b. We saw [John stroke the dog]_S.
 c. [John's stroking the dog]_S delighted us.

are all [-tense] and are therefore closed, and can be theta-marked arguments of the heads.⁸ Given the close relation between COMP and tense, it is to be predicted that tense-less Ss are also COMP-less. The primary function of COMP is connected with tense, and COMP can be considered a projection of tense. This prediction is borne out -- all the Ss in (33) are COMP-less and wh-movement within the lower clause is impossible.

- (34) a. *We consider [what₁[John t₁]_S]_S, (cf we consider John what?)
 b. *We saw [what₁[John stroke t₁]_S]_S,
 c. *[What₁[John's stroking t₁]_S]_S, delighted us.

We can also explain a third fact pointed out in Stowell (1982). He suggests that infinitivals are unrealized with respect to tense in S' embedded clauses like (35):

- (35) We persuaded John [[PRO to go]_S]_S,

However in (36) where the matrix verb deletes S' the tense of the embedded clause is determined by the matrix verb. The tense of the embedded clause is future in (35a), and past in (36b):

- (36) a. I expect [John to win the race]_S .
 b. I considered [John to be the smartest]_S .

This follows from the fact that in (35) the embedded clause has its own COMP, by which the tense variable is bound. In (36) there is no lower COMP, as a result of S' deletion, and the tense of the embedded S has to be bound by the tense-operator of the higher clause.

6.2.3 We have suggested that Ss like those in (33b) and (33c) are [-tense]. However, they still appear to be inflected (cf. the discussion in 5.2). If we separate the notions of tense and inflection we are left asking what exactly INFL is. One suggestion is that INFL is an argument of a verbal head. Davidson (1966) in the "Logical Form of Action Sentences" suggests that in all action sentences (at least indicative ones) there is a quantification over events. He argues that in (37) kick

- (37) John kicked Bill.

is not a two-place predicate but a three-place relation between John, Bill and an event, and it should have a semantic representation as in (38):

(38) $[\exists x: x \text{ an event}] \text{ kicked (John, Bill, } x.)$

If kick is such a three-place predicate then it is plausible to think of the event quantifier as residing in the non-tensed INFL. A full semantic representation of (37) will make explicit quantification over time as well as over events: e.g.,

(39) $[\exists x: x \text{ an event}] [\exists t: t \text{ a time}] \text{ kick (John, Bill, } x) \text{ and}$

$R (x ,t) \text{ and } t \text{ is past}$

where R denotes the relation " x took place at t ".

This analysis allows us to explain the occurrence of inflected non-tensed verbal forms such as the gerund, and the naked infinitive. These forms allow no quantification over time, but do still maintain quantification over events. This is why the S complements of

- (40) a. I saw John leave.
b. I saw John leaving.

are understood as nominals and not as tensed propositions.

6.3 This analysis of inflection as an argument allows us to solve an outstanding problem involving these locative, temporal and manner PPs which require to be linked to formal subjects but which do not appear to be linked to anything at S -structure, cf the examples in (41):

- (41) a. It snowed for three hours.
 b. He screamed in a wild fury.
 c. She ate with a fork and knife.

None of the PPs in (41) have any NP to be linked to. In (41b) and (41c) there is no [NP VP] to act as subject, and in (41a) where the PP is hung from S, the [NP S] is a pleonastic which is not a possible subject of a secondary predicate. Yet, as these PPs are not theta-marked, they must be predicated of something. A solution is suggested by Davidson's analysis of the logical structure of sentences which are analogous to (41). He proposed (43) as a semantic representation of (42):

(42) I flew my spaceship to the Evening Star.

(43) [$\exists x$: x an event] flew (I, my spaceship, x) and
 To (the Evening Star, x).

The locative PP in (42) is being predicated of the event, which is an argument of the head as much as the NPs I and my spaceship. The syntactic correlate of (43) is an analysis of the PP, to the Evening Star, as a predicate of INFL. It is thus able to meet the requirements of the predicate-linking rule.

We may ask why PPs and no other lexical categories can be predicated of INFL. The answer lies in the fact that the secondary predicates, AP and NP, assign theta-roles to their subjects

and the NPs they are predicated of have to be lexical and thus capable of being assigned theta-roles. PP, as we discussed in 3.1, does not assign a theta-role to its subject but designates its external argument as a particular argument of the relation denoted by the head of the PP. Thus in (43), the event is the second argument in the two-place, locative relation defined by the preposition To.

We predict that other XPs which do not assign theta-roles to their subjects can also be predicated of INFL. The only XP which satisfies this criterion is S', and the prediction is borne out. S' can be linked to INFL to satisfy the predicate-linking rule. e.g.

(44) We ran [because we were late]_{S'}.

which has a semantic representation

(45) $[\exists x: x \text{ an event}] \text{ Ran (We, } x) \text{ and Because (x, 'we were late')}$.

One final point must be made. Davidson discusses only quantification over events. Yet INFL is present in non-action verbs like

- (46) a. John owns a house.
b. John's owning a house delighted his parents.

It also occurs with predicate adjectives and predicate nominals, e.g.

- (47) a. John is foolish.
b. John is a genius.

It seems that we must allow INFL to quantify over states as well as actions, in order to account for the variety of structures available in natural language.

FOOTNOTES

- (1) Except, of course, for the predicates like snow which have no notional subject, and presumably constitute degenerate propositions at SR.
- (2) We mentioned briefly in Chapter II that in some languages (and possibly even English) locative PPs should be analyzed as arguments, and therefore closed. A PP has the internal structure of (i)

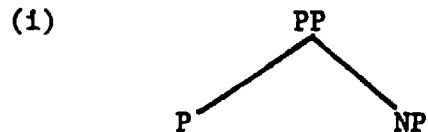

The preposition is interpreted as defining a relation (locative, temporal, etc.) between the NP it governs, and the NP that the whole PP is linked to. Presumably, in the restricted cases where a PP is an argument, it has been reduced to a one-place relation, and is not linked. There must be strict semantic restrictions on where this reduction can take place -- indicated by the fact that only locative PPs seem to undergo this process.

- (3) Pleonastics are marginally acceptable to some people in gerunds (and totally unacceptable to others) e.g., its raining yesterday upset us. A possible explanation is that a gerund has the structure

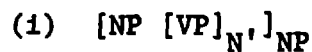

where the verbal head has been "de-verbalized" (possibly by the addition of the +nominal affix -ing). Although the VP can be predicated of the NP because it is a maximal projection, the rule of pleonastic insertion sees only the N' and, blind to the VP it immediately dominates, does not insert a pleonastic.

- (4) Note that in (i)

(i) That is the man

the identificational be is being used, and both the man and That are assigned theta-roles.

- (5) Note that a structural constraint analogous to the c-command condition is involved here. C-command defined in terms of maximal projections clearly is not involved within NPs. However in (20) (and also (23)), where the AP is bound by the determiner the first branching node dominating the one also dominates the other. This is not the case in (21).
- (6) This is possible only when there is a deleted complementizer
- (1) We persuaded John (that) he leaves at dawn.
- (7) Cf. the explanation in Chapter V for the theta-marked infinitival complements of S' deletion verbs.
- (8) Non-inflected Ss, like the object of consider in
- (i) We consider John a genius,
- do not appear in subject position.
- (ii) *[John a fool] is obvious
- (ii) is ruled out by the case filter, as there is no way for John to be assigned case. This predicts that the following structures should be acceptable, as John can receive case from consider.
- (iii) We consider [[John a fool]_S drunk]_S .
- (iv) We consider [[John a fool]_S obvious]_S.
- (iii) is uninterpretable with the S subject (although OK with a fool the primary predicate, and drunk the secondary predicate of John This is because drunk does not assign the theta-role proposition to its subject position, but requires a [+animate] NP subject. (iv) should be marginally acceptable in the sense of "we consider that John is a fool is obvious." It is clearly more acceptable than (iii) and its marginal status may well be due to processing difficulties.

BIBLIOGRAPHY

- Andrews, Avery. (1982) "The Representation of Case in Modern Icelandic" in J. Bresnan, ed., The Mental Representation of Grammatical Relations, MIT Press, Cambridge, Mass.
- Aoun, J. and D. Sportiche. (1982) "On the Formal Theory of Government" ms, MIT and UQAM.
- Aristotle. Collected Works, ed. R. McKeon, Random House 1941.
- Austin, John L. (1962) Sense and Sensibilia, ed. G.J. Warnock O.U.P.
- Barwise, John and R. Cooper. (1981) "Generalized Quantifiers and Natural Language," Linguistics and Philosophy 4, p. 159-219.
- Bresnan, Joan, ed. (1982) The Mental Representation of Grammatical Relations, MIT Press, Cambridge, Mass.
- Burzio, Luigi. (1981) Intransitive Verbs and Italian Auxiliaries, PhD Dissertation, MIT.
- Chomsky, Noam. (1957) Syntactic Structures, Mouton, The Hague.
- Chomsky, Noam. (1970) Remarks on Nominalization, in Jacobs and Rosenbaum, eds.
- Chomsky, Noam. (1981) Lectures on Government and Binding, Foris, Dordrecht.
- Chomsky, Noam. (1982) Some Concepts and Consequences of the Theory of Government and Binding, MIT Press, Cambridge, Mass.
- Davidson, D. (1967) "The Logical Form of Action Sentences," in Essays on Actions and Events (1980) O.U.P.
- den Besten, H. (1978) "Auxiliary Deletions and the Interplay Between Local Deletive Rules and Filters" paper presented to the 1978 GLOW Colloquium.
- Fabb, N. (1982) "How to Do Things with Verbs," MIT ms.
- Frege, G. (1891) "Function and Concept" in ed. Geach, P. and M. Black Translations from the Philosophical Writings of Gottlob Frege 1952.
- Gruber, J. (1965) Studies in Lexical Relations, PhD dissertation, MIT. also Indiana University Linguistics Club.
- Halliday, M.A. K. (1967) "Notes on Transitivity and Theme in English Part I." Journal of Linguistics 3, p. 37-81.
- Higginbotham, James. (1983a) "The Logic of Perceptual Reports," J. of Philosophy LXXX 2.

- Higginbotham, James. (1983b) "LF, Binding and Nominals," LI 14/3.
- Huang, C.T.J. (1982) Logical Relations in Chinese and the Theory of Grammar, PhD dissertation, MIT.
- Jackendoff, Ray. (1972) Semantic Interpretation in Generative Grammar MIT Press, Cambridge, Mass.
- Jackendoff, Ray. (1975) "Morphological and Semantic Regularities in the Lexicon," Language 51/3.
- Jackendoff, Ray. (1976) "Towards an Explanatory Semantic Representation" LI 8/1, p. 88-150.
- Jackendoff, Ray. (1977) X' Syntax: A Study of Phrase Structure, MIT Press, Cambridge, Mass.
- Jacobs, R. and P. Rosenbaum, eds. (1970) Readings in English Transformational Grammar, Blaisdell, Waltham, Mass.
- * Levin, Beth (to appear) "Unaccusative Verbs in Basque," NELS 13.
- Levin, Beth. (1983) On the Nature of Ergativity, PhD dissertation, MIT.
- Levin, Juliette. (1983) "Government Relations and the Structure of INFL," MIT ms.
- Levin, Lori S. (1981) "Lexical Representation of Quirky Case in Icelandic," MIT ms.
- Levin, Lori, S. (1983) Operations on Lexical Forms, PhD dissertation, MIT.
- Levin, Lori S. and Jane Simpson. (1981) "Quirky Case and the Structure of Icelandic Lexical Entries," CLS 17, p. 185-195.
- Marantz, Alec. (1980) "English S is the Maximal Projection of V," paper presented to 1980 NELS conference.
- Marantz, Alec. (1981) On the Nature of Grammatical Relations, PhD dissertation, MIT. To appear, MIT Press, Cambridge, Mass.
- Marantz, Alec and Timothy Stowell, eds. (1982) MIT Working Papers in Linguistics, Vol. 4.
- May, R. (1977) The Grammar of Quantification, PhD dissertation, MIT.

- May, R. (1982) "Logical Form as a Level of Linguistic Representation" ms. Columbia University.
- Perlmutter, David. (1978) "Impersonal Passives and the Unaccusative Hypothesis," in J. Jaeger et. al., eds. BLS 4, p. 157-189.
- Pesetsky, David. (1982) Paths and Categories, PhD dissertation, MIT.
- Quine, W.V. (1941) Elementary Logic, Boston, Ginn.
- Quine, W.V. (1959) Methods of Logic, Holt, New York.
- Rescher, N. (1962) "Plurality Quantification" abstract, Journal of Symbolic Logic 27, 373-374.
- Reuland, E. (1983) "Governing -ing," LI 14/1.
- Safir, K. (1982) Syntactic Chains and the Definiteness Effect, PhD dissertation, MIT.
- Schachter, P. (1976) "A non-Transformational Account of Gerundive Nominals in English," LI 7/2.
- Schein, Barry. (1982a) "Non-finite Clauses in Russian," in Marantz and Stowell, eds., MIT Working Papers in Linguistics, Vol. 4.
- Schein, Barry. (1982b) "Small Clauses and Predication," ms. MIT.
- Simpson, Jane. (1982) "Secondary Predicates in English, Icelandic and Finnish," ms. MIT.
- Stowell, Timothy. (1978) "What Was There Before There Was There," in D. Farkas, et. al. eds., CLS 14.
- Stowell, Timothy. (1981) Origins of Phrase Structure, PhD dissertation, MIT.
- Stowell, Timothy. (1982) "The Tense of Infinitives," LI 13/4.
- Stowell, Timothy. (to appear) "Subjects Across Categories," in Linguistic Review.
- Thiersch, C. (to appear)
- Torrego, E. (to appear) "Determinerless NPs", MIT ms.
- Williams, Edwin. (1975) "Small Clauses in English," in J. Kimball, ed. Syntax and Semantics, Vol. IV, Academic Press, NY.
- Williams, Edwin. (1980) "Predication," LI 11/1.

- Williams, Edwin. (1981) "Argument Structure and Morphology,"
Linguistic Review, 1/1.
- Williams, Edwin. (1982) "Small Clauses," ms. University of Massa-
chusetts, Amherst.
- Zagona, Karen. (1982) Government and Proper Government of Verbal
Projections, PhD dissertation, U. of Washington.
- Zubizarreta, Maria-Luisa and Jean-Roger Vergnaud. (1982) "On Virtual
Categories," in Marantz and Stowell, eds., MIT Working Papers
in Linguistics, Vol. 4.
- *Koster, J. (1978) "Why Subject Sentences Don't Exist", in S.J.
Keyser, ed., Recent Transformational Studies in European
Languages, MIT Press, Cambridge, Mass.