

Research Article

The Time-Fractional Coupled-Korteweg-de-Vries Equations

Abdon Atangana¹ and Aydin Secer²

¹ *Institute for Groundwater Studies, Faculty of Natural and Agricultural Sciences,
University of the Free State, Bloemfontein 9300, South Africa*

² *Department of Mathematical Engineering, Yildiz Technical University, Davutpasa, 34210 Istanbul, Turkey*

Correspondence should be addressed to Aydin Secer; asecer@yildiz.edu.tr

Received 5 January 2013; Accepted 7 February 2013

Academic Editor: Mustafa Bayram

Copyright © 2013 A. Atangana and A. Secer. This is an open access article distributed under the Creative Commons Attribution License, which permits unrestricted use, distribution, and reproduction in any medium, provided the original work is properly cited.

We put into practice a relatively new analytical technique, the homotopy decomposition method, for solving the nonlinear fractional coupled-Korteweg-de-Vries equations. Numerical solutions are given, and some properties exhibit reasonable dependence on the fractional-order derivatives' values. The fractional derivatives are described in the Caputo sense. The reliability of HDM and the reduction in computations give HDM a wider applicability. In addition, the calculations involved in HDM are very simple and straightforward. It is demonstrated that HDM is a powerful and efficient tool for FPDEs. It was also demonstrated that HDM is more efficient than the adomian decomposition method (ADM), variational iteration method (VIM), homotopy analysis method (HAM), and homotopy perturbation method (HPM).

1. Introduction

Fractional calculus has been used to model physical and engineering processes, which are found to be best described by fractional differential equations. It is worth nothing that the standard mathematical models of integer-order derivatives, including nonlinear models, do not work adequately in many cases. In the recent years, fractional calculus has played a very important role in various fields such as mechanics, electricity, chemistry, biology, economics, notably control theory, signal image processing, and groundwater problems. In the past several decades, the investigation of travelling-wave solutions for nonlinear equations has played an important role in the study of nonlinear physical phenomena. In [1], homotopy analysis method is applied to obtain approximate analytical solution of the modified Kuramoto-Sivashinsky equation. In addition to that an excellent literature of this can be found in [2–11]. Analytical solutions of these equations are usually not available. Since only limited classes of equations are solved by analytical means, numerical solution of these nonlinear partial differential equations is of practical importance.

In this paper, we extend the application of the homotopy decomposition method (HDM) in order to derive analytical

approximate solutions to nonlinear time-fractional coupled-KDV equations. This coupled system is used to describe iterations of water waves proposed by Hirota and Satsuma [12]. The HDM was recently applied to solve the fractional modified Kawahara equation, fractional model of HIV infection of CD4+T cells, the attractor fractional one-dimensional Keller-Segel equations, the fractional Jaulent-Miodek and Whitham-Broer-Kaup equations, the fractional Riccati differential equation, fractional nonlinear predator-prey population, and the fractional nonlinear system predator-prey population. The relatively new technique that approached the HDM is a promising analytical technique to solve nonlinear fractional partial and ordinary differential equations. The fractional systems of partial differential equations under investigation here are given as

$$\begin{aligned} \frac{\partial^\alpha u(x,t)}{\partial t^\alpha} + 6au(x,t)u_x(x,t) - 2bv(x,t)v_x(x,t) \\ + au_{x,x,x}(x,t) = 0, \quad 0 < \alpha \leq 1, \\ \frac{\partial^\beta v(x,t)}{\partial t^\beta} + 3bu(x,t)v_x(x,t) \\ + bv_{x,x,x}(x,t) = 0, \quad 0 < \beta \leq 1. \end{aligned} \quad (1)$$

Subject to the initial conditions

$$\begin{aligned}
 u(x, 0) &= \frac{\lambda}{a} \left(\operatorname{sech} \left(\frac{1}{2} \sqrt{\frac{\lambda}{a}} x \right) \right)^2, \\
 v(x, 0) &= \frac{\lambda}{\sqrt{2a}} \left(\operatorname{sech} \left(\frac{1}{2} \sqrt{\frac{\lambda}{a}} x \right) \right)^2.
 \end{aligned}
 \tag{2}$$

The remaining of this paper is structured as follows: in Section 2 we present a brief history of the fractional derivative order and their properties. We present the basic ideal of the homotopy decomposition method for solving high-order nonlinear fractional partial differential equations. We present the application of the HDM for system fractional nonlinear differential equations (1) and numerical results in Section 4. The conclusions are then given in Section 5.

2. Fractional Derivative Order

2.1. Brief History. In the literature, one can find several definitions of fractional derivatives. The most common used are the Riemann-Liouville and the Caputo derivatives. For Caputo we have

$${}_0^C D_x^\alpha (f(x)) = \frac{1}{\Gamma(n-\alpha)} \int_0^x (x-t)^{n-\alpha-1} \frac{d^n f(t)}{dt^n} dt. \tag{3}$$

For the case of Riemann-Liouville we have the following definition:

$$D_x^\alpha (f(x)) = \frac{1}{\Gamma(n-\alpha)} \frac{d^n}{dx^n} \int_0^x (x-t)^{n-\alpha-1} f(t) dt. \tag{4}$$

Each fractional derivative presents some advantages and disadvantages [13, 14]. The Riemann-Liouville derivative of a constant is not zero while Caputo's derivative of a constant is zero but demands higher conditions of regularity for differentiability: to compute the fractional derivative of a function in the Caputo sense, we must first calculate its derivative. Caputo derivatives are defined only for differentiable functions while functions that have no first-order derivative might have fractional derivatives of all orders less than one in the Riemann-Liouville sense [15, 16]. Recently, Jumarie (see [17, 18]) proposed a simple alternative definition to the Riemann-Liouville derivative:

$$D_x^\alpha (f(x)) = \frac{1}{\Gamma(n-\alpha)} \frac{d^n}{dx^n} \int_0^x (x-t)^{n-\alpha-1} \{f(t) - f(0)\} dt. \tag{5}$$

His modified Riemann-Liouville derivative seems to have advantages of both the standard Riemann-Liouville and Caputo fractional derivatives: it is defined for arbitrary continuous (nondifferentiable) functions and the fractional derivative of a constant is equal to zero. However, the Jumarie fractional derivative gives the fractional derivative of $f(x) - f(0)$ not for $f(x)$, this implies that, there is no fractional derivative for some functions that are not defined at the origin, for instance $\ln(x)$ [19].

We can point out that Caputo and Riemann-Liouville may have their disadvantages but they still remain the best definitions of the fractional derivative. Every definition must be used accordingly [19].

2.2. Properties and Definitions

Definition 1. A real function $f(x)$, $x > 0$ is said to be in the space C_μ , $\mu \in \mathbb{R}$ if there exists a real number $p > \mu$, such that $f(x) = x^p h(x)$, where $h(x) \in C[0, \infty)$, and it is said to be in space C_μ^m if $f^{(m)} \in C_\mu$, $m \in \mathbb{N}$.

Definition 2. The Riemann-Liouville fractional integral operator of order $\alpha \geq 0$, of a function $f \in C_\mu$, $\mu \geq -1$, is defined as

$$\begin{aligned}
 J^\alpha f(x) &= \frac{1}{\Gamma(\alpha)} \int_0^x (x-t)^{\alpha-1} f(t) dt, \quad \alpha > 0, x > 0, \\
 J^0 f(x) &= f(x).
 \end{aligned}
 \tag{6}$$

Properties of the operator can be found in [15, 16], and one mentions only the following:

for $f \in C_\mu$, $\mu \geq -1$, $\alpha, \beta \geq 0$, and $\gamma > -1$:

$$\begin{aligned}
 J^\alpha J^\beta f(x) &= J^{\alpha+\beta} f(x), \\
 J^\alpha J^\beta f(x) &= J^\beta J^\alpha f(x) J^\alpha x^\gamma = \frac{\Gamma(\gamma+1)}{\Gamma(\alpha+\gamma+1)} x^{\alpha+\gamma}.
 \end{aligned}
 \tag{7}$$

Lemma 3. If $m - 1 < \alpha \leq m$, $m \in \mathbb{N}$ and $f \in C_\mu^m$, $\mu \geq -1$, then

$$\begin{aligned}
 D^\alpha J^\alpha f(x) &= f(x), \\
 J^\alpha D_0^\alpha f(x) &= f(x) - \sum_{k=0}^{m-1} f^{(k)}(0^+) \frac{x^k}{k!}, \quad x > 0.
 \end{aligned}
 \tag{8}$$

Definition 4 (partial derivatives of fractional order). Assume now that $f(x)$ is a function of n variables x_i , $i = 1, \dots, n$ also of class C on $D \in \mathbb{R}_n$. As an extension of Definition 4, one defines partial derivative of order α for f with respect to x_i the function

$$a \partial_{x_i}^\alpha f = \frac{1}{\Gamma(m-\alpha)} \int_a^{x_i} (x_i-t)^{m-\alpha-1} \partial_{x_i}^m f(x_j) \Big|_{x_j=t} dt, \tag{9}$$

if it exists, where $\partial_{x_i}^m$ is the usual partial derivative of integer-order m .

3. Basic Idea of the HDM

To illustrate the basic idea of this method, we consider a general nonlinear nonhomogeneous fractional partial differential equation with initial conditions of the following form:

$$\frac{\partial^\alpha U(x, t)}{\partial t^\alpha} = L(U(x, t)) + N(U(x, t)) + f(x, t), \quad \alpha > 0. \tag{10}$$

Subject to the initial condition

$$\begin{aligned}
 D_0^{\alpha-k}U(x, 0) &= f_k(x), \quad (k = 0, \dots, n-1), \\
 D_0^{\alpha-n}U(x, 0) &= 0, \quad n = [\alpha], \\
 D_0^kU(x, 0) &= g_k(x), \quad (k = 0, \dots, n-1), \\
 D_0^nU(x, 0) &= 0, \quad n = [\alpha],
 \end{aligned}
 \tag{11}$$

where $\partial^\alpha/\partial t^\alpha$ denotes the Caputo or Riemann-Liouville fraction derivative operator, f is a known function, N is the general nonlinear fractional differential operator, and L represents a linear fractional differential operator. The method first step here is to transform the fractional partial differential equation to the fractional partial integral equation by applying the inverse operator $\partial^\alpha/\partial t^\alpha$ of both sides of (10) to obtain the following. In the case of Riemann-Liouville fractional derivative

$$\begin{aligned}
 U(x, t) &= \sum_{j=1}^{n-1} \frac{f_j(x)}{\Gamma(\alpha-j+1)} t^{\alpha-j} \\
 &+ \frac{1}{\Gamma(\alpha)} \int_0^t (t-\tau)^{\alpha-1} \left[L(U(x, \tau)) + N(U(x, \tau)) \right. \\
 &\quad \left. + f(x, \tau) \right] d\tau.
 \end{aligned}
 \tag{12}$$

In the case of Caputo fractional derivative

$$\begin{aligned}
 U(x, t) &= \sum_{j=1}^{n-1} \frac{g_j(x)}{\Gamma(\alpha-j+1)} t^j \\
 &+ \frac{1}{\Gamma(\alpha)} \int_0^t (t-\tau)^{\alpha-1} \left[L(U(x, \tau)) + N(U(x, \tau)) \right. \\
 &\quad \left. + f(x, \tau) \right] d\tau,
 \end{aligned}
 \tag{13}$$

or in general by putting

$$\sum_{j=1}^{n-1} \frac{f_j(x)}{\Gamma(\alpha-j+1)} t^{\alpha-j} = f(x, t) \quad \text{or} \quad f(x, t) = \sum_{j=1}^{n-1} \frac{g_j(x)}{\Gamma(\alpha-j+1)} t^j,
 \tag{14}$$

we obtain the following:

$$\begin{aligned}
 U(x, t) &= T(x, t) \\
 &+ \frac{1}{\Gamma(\alpha)} \int_0^t (t-\tau)^{\alpha-1} \left[L(U(x, \tau)) + N(U(x, \tau)) \right. \\
 &\quad \left. + f(x, \tau) \right] d\tau.
 \end{aligned}
 \tag{15}$$

In the homotopy decomposition method, the basic assumption is that the solutions can be written as a power series in p

$$U(x, t, p) = \sum_{n=0}^{\infty} p^n U_n(x, t),
 \tag{16a}$$

$$U(x, t) = \lim_{p \rightarrow 1} U(x, t, p),
 \tag{16b}$$

and the nonlinear term can be decomposed as

$$NU(x, t) = \sum_{n=0}^{\infty} p^n \mathcal{H}_n(U),
 \tag{17}$$

where $p \in (0, 1]$ is an embedding parameter. $\mathcal{H}_n(U)$ is the He's polynomials that can be generated by

$$\begin{aligned}
 \mathcal{H}_n(U_0, \dots, U_n) \\
 = \frac{1}{n!} \frac{\partial^n}{\partial p^n} \left[N \left(\sum_{j=0}^{\infty} p^j U_j(x, t) \right) \right], \quad n = 0, 1, 2, \dots
 \end{aligned}
 \tag{18}$$

The homotopy decomposition method is obtained by the graceful coupling of homotopy technique with the Abel integral and is given by

$$\begin{aligned}
 \sum_{n=0}^{\infty} p^n U_n(x, t) - T(x, t) \\
 = \frac{p}{\Gamma(\alpha)} \int_0^t (t-\tau)^{\alpha-1} \left[f(x, \tau) + L \left(\sum_{n=0}^{\infty} p^n U_n(x, \tau) \right) \right. \\
 \left. + N \left(\sum_{n=0}^{\infty} p^n U_n(x, \tau) \right) \right] d\tau.
 \end{aligned}
 \tag{19}$$

Comparison of the terms of same powers of p gives solutions of various orders with the first term:

$$U_0(x, t) = T(x, t).
 \tag{20}$$

3.1. Convergence of the Method and Unicity of the Solution

Theorem 5 (see [19]). *Assuming that $X \times T \subset \mathbb{R} \times \mathbb{R}^+$ is a Banach space with a well-defined norm $\|\cdot\|$, over which the series sequence of the approximate solution of (1) is defined, and the operator $G(U_n(x, t)) = U_{n+1}(x, t)$ defining the series solution of (16b) satisfies the Lipschitzian conditions that is $\|G(U_k^*) - G(U_k)\| \leq \varepsilon \|U_k^*(x, t) - U_k(x, t)\|$ for all $(x, t, k) \in X \times T \times \mathbb{N}$, then series solution obtained (16b) is unique.*

Proof. Assume that $U(x, t)$ and $U^*(x, t)$ are the series solution satisfying (1), then $U^*(x, t, p) = \sum_{n=0}^{\infty} p^n U_n^*(x, t)$ with initial guess $T(x, t)$; $U(x, t, p) = \sum_{n=0}^{\infty} p^n U_n(x, t)$ also with initial guess $T(x, t)$; therefore,

$$\|U_n^*(x, t) - U_n(x, t)\| = 0, \quad n = 0, 1, 2, \dots
 \tag{21}$$

By the recurrence for $n = 0$, $U_n^*(x, t) = U_n(x, t) = T(x, t)$, assume that for $n > k \geq 0$, $\|U_k^*(x, t) - U_k(x, t)\| = 0$. Then

$$\begin{aligned} \|U_{k+1}^*(x, t) - U_{k+1}(x, t)\| &= \|G(U_k^*) - G(U_k)\| \\ &\leq \varepsilon \|U_k^*(x, t) - U_k(x, t)\| = 0, \end{aligned} \tag{22}$$

which completes the proof. \square

3.2. Complexity of the Homotopy Decomposition Method. It is very important to test the computational complexity of a method or algorithm. Complexity of an algorithm is the study of how long a program will take to run, depending on the size of its input and long of loops made inside the code. We compute a numerical example which is solved by the homotopy decomposition method. The code has been presented with Mathematica 8 according to the following code [19].

Step 1. Set $m \leftarrow 0$.

Step 2. Calculating the recursive relation after the comparison of the terms of the same power is done.

Step 3. If $\|U_{n+1}(x, t) - U_n(x, t)\| < r$ with r the ratio of the neighbourhood of the exact solution [5] then go to Step 4, else $m \leftarrow m + 1$ and go to Step 2

Step 4. Print out

$$U(x, t) = \sum_{n=0}^{\infty} U_n(x, t), \tag{23}$$

as the approximate of the exact solution.

Lemma 6. *If the exact solution of the fractional partial differential equation (10) exists, then*

$$\|U_{n+1}(x, t) - U_n(x, t)\| < r \quad \forall (x, t) \in X \times T. \tag{24}$$

Proof. Let $(x, t) \in X \times T$, then since the exact solution exists, then we have that following:

$$\begin{aligned} &\|U_{n+1}(x, t) - U_n(x, t)\| \\ &= \|U_{n+1}(x, t) - U(x, t) + U(x, t) - U_n(x, t)\| \\ &\leq \|U_{n+1}(x, t) - U(x, t)\| + \|-U_n(x, t) + U(x, t)\| \\ &\leq \frac{r}{2} + \frac{r}{2} = r. \end{aligned} \tag{25}$$

The last inequality follows from [19]. \square

Lemma 7. *The complexity of the homotopy decomposition method is of order $O(n)$.*

Proof. The number of computations including product, addition, subtraction, and division are in Step 2

U_0 : is 0 because, it is obtained directly form the initial guess $T(x, t)$ [19].

$$\begin{aligned} U_1: &3 \\ &\vdots \\ U_n: &3. \end{aligned}$$

Now in Step 4, the total number of computations is equal to $\sum_{j=0}^n U_j(x, t) = 3n = O(n)$. \square

4. Application

In learning science, examples are useful than rules (Isaac Newton). In this section, we apply this method for solving system of fractional differential equation. Following carefully the steps involved in the HDM, we arrive at the following equations:

$$\begin{aligned} &\sum_{n=0}^{\infty} p^n u_n(x, t) \\ &= u(x, 0) \\ &\quad - \frac{p}{\Gamma(\alpha)} \int_0^t (t-\tau)^{\alpha-1} \left(6a \sum_{n=0}^{\infty} p^n u_n \left(\sum_{n=0}^{\infty} p^n u_n \right)_x \right. \\ &\quad \left. - 2b \sum_{n=0}^{\infty} p^n v_n \left(\sum_{n=0}^{\infty} p^n v_n \right)_x \right) \\ &\quad + \left(\sum_{n=0}^{\infty} p^n u_n \right)_{x,x,x}, \\ &\sum_{n=0}^{\infty} p^n v_n(x, t) \\ &= v(x, 0) \\ &\quad - \frac{p}{\Gamma(\beta)} \int_0^t (t-\tau)^{\beta-1} \left(\left(6a \sum_{n=0}^{\infty} p^n u_n \left(\sum_{n=0}^{\infty} p^n u_n \right)_x \right. \right. \\ &\quad \left. \left. + 3b \sum_{n=0}^{\infty} p^n u_n \left(\sum_{n=0}^{\infty} p^n v_n \right)_x \right) \right. \\ &\quad \left. \times b \left(\sum_{n=0}^{\infty} p^n u_n \right)_{x,x,x} \right). \end{aligned} \tag{26}$$

If we compare the terms of the same power of p we obtain the following integral equations. Note that when comparing this approach with the methodology of the homotopy perturbation method, one will obtain in this step a set of ordinary differential equations something which needs to be also solved with care, because one will need to choose an appropriate initial guest. But with the current approach, the initial guess is straightforwardly obtained as the Taylor series of the exact solution of the problem under investigation; this is one of the advantages that the approach has over the HPM [22]. On the other hand, when comparing this approach with the variational iteration method [23], one will find out that we do need the Lagrange multiplier here or the

correctional function. Also this approach provides us with a convenient way to control the convergence of approximation series without adapting h , as in the case of [24] which is a fundamental qualitative difference in analysis between HDM and other methods. Therefore, comparing the terms of the same power we obtain

$$\begin{aligned}
 p^0 : u_0(x, t) &= u(x, 0), \quad u_0(x, 0) = u(x, 0), \\
 p^0 : u_0(x, t) &= u(x, 0), \quad u_0(x, 0) = u(x, 0), \\
 p^1 : u_1(x, t) &= -\frac{1}{\Gamma(\alpha)} \\
 &\quad \times \int_0^t (t-\tau)^{\alpha-1} (6au_0(u_0)_x - 2bv_0(v_0)_x \\
 &\quad \quad + a(u_0)_{xxx}) d\tau, \\
 &\quad u_1(x, 0) = 0, \\
 p^1 : v_1(x, t) &= -\frac{1}{\Gamma(\beta)} \int_0^t (t-\tau)^{\beta-1} \\
 &\quad \times (3bu_0(v_0)_x + b(u_0)_{xxx}) d\tau, \\
 &\quad v_1(x, 0) = 0, \\
 &\quad \vdots \\
 p^n : u_n(x, t) &= -\frac{1}{\Gamma(\alpha)} \int_0^t (t-\tau)^{\alpha-1} \\
 &\quad \times \left(6a \sum_{i=0}^{n-1} u_i(u_{n-i-1})_x - 2b \sum_{i=0}^{n-1} v_i(v_{n-i-1})_x \right. \\
 &\quad \quad \left. + a(u_{n-1})_{xxx} \right) d\tau, \\
 u_n(x, t) &= 0, \\
 p^n : v_n(x, t) &= -\frac{1}{\Gamma(\alpha)} \int_0^t (t-\tau)^{\alpha-1} \\
 &\quad \times \left(3b \sum_{i=0}^{n-1} u_i(v_{n-i-1})_x + b(v_{n-1})_{xxx} \right) d\tau, \\
 v_n(x, t) &= 0.
 \end{aligned} \tag{27}$$

Integrating the above, we obtain the following series solutions:

$$\begin{aligned}
 u_0(x, t) &= \frac{\lambda}{a} \left(\operatorname{sech} \left(\frac{1}{2} \sqrt{\frac{\lambda}{a}} x \right) \right)^2, \\
 v_0(x, t) &= \frac{\lambda}{\sqrt{2a}} \left(\operatorname{sech} \left(\frac{1}{2} \sqrt{\frac{\lambda}{a}} x \right) \right)^2.
 \end{aligned} \tag{28}$$

For the sake of simplicity we put the following:

$$\begin{aligned}
 d &= \frac{\lambda}{a}, \quad d_1 = \frac{\lambda}{\sqrt{2a}}, \quad m = \frac{1}{2} \sqrt{\frac{\lambda}{a}}, \\
 u_1(x, t) &= \frac{4mt^\alpha}{\Gamma(1+\alpha)} \\
 &\quad \times (-bd_1^2 + ad(3d - 5m^2) + adm^2 \cosh(2mx)) \\
 &\quad \times (\operatorname{sech}(mx))^4 \tanh(mx), \\
 v_1(x, t) &= \frac{2bd_1mt^\beta}{\Gamma(1+\beta)} (3d - 10m^2 + 2m^2 \cosh(2mx)) \\
 &\quad \times (\operatorname{sech}(mx))^4 \tanh(mx), \\
 u_2(x, t) &= \frac{1}{\Gamma(1+\alpha)\Gamma(1+\beta)\Gamma(0.5+\alpha)\Gamma(1+\alpha+\beta)} \\
 &\quad \times (2^{1-2\alpha}m^2\sqrt{\pi}t^\alpha\Gamma(1+\beta) \\
 &\quad \times (-2b^2d_1^2t^\beta \\
 &\quad \times (-12d + 44m^2 + (9d - 38m^2) \\
 &\quad \times \cosh(2mx) + 2m^2 \cosh(4mx) \\
 &\quad \times \Gamma(1+2\alpha) + at^\alpha \\
 &\quad \times (-8(2bd_1^2(-3d + 13m^2) \\
 &\quad \quad + ad(18d^2 - 111dm^2 + 151m^4)) \\
 &\quad \quad + (4bd_1^2(-9d + 49m^2) \\
 &\quad \quad + 3ad(36d^2 - 272dm^2 + 397m^4))) \\
 &\quad \times \cosh(2mx) \\
 &\quad - 4m^2(4bd_1^2 - 15ad(d - 2m^2)) \\
 &\quad \times \cosh(4mx) + adm^4 \cosh(6xm)) \\
 &\quad \times \Gamma(1+\alpha+\beta) (\operatorname{sech}(mx))^8),
 \end{aligned}$$

$$\begin{aligned}
 v_2(x, t) &= \frac{1}{\Gamma(1 + \alpha) \Gamma(1 + \beta) \Gamma(0.5 + \alpha) \Gamma(1 + \alpha + \beta)} \\
 &\times \left(2^{1-2\beta} m^2 \sqrt{\pi} t^\beta \Gamma(1 + \alpha) (\operatorname{sech}(mx))^8 \right. \\
 &\quad \times \left(bt^\beta (-27d^2 + 411dm^2 - 1208m^4 \right. \\
 &\quad \quad + 3(6d^2 - 124dm^2 + 397m^4) \\
 &\quad \quad \times \cosh(2mx) + 3m^2(9d - 40m^2) \\
 &\quad \quad \times \cosh(4mx) + m^4 \cosh(6mx) \\
 &\quad \times \Gamma(1 + \alpha + \beta) \\
 &\quad + 12t^\alpha (-bd_1^2 + ad(3d - 5m^2) \\
 &\quad \quad \left. + adm^2 \cosh(2mx) \right) \Gamma(1 + 2\beta) \\
 &\quad \left. \times (\sinh(mx))^2 \right). \tag{29}
 \end{aligned}$$

And so on, using the package Mathematica, in the same manner, one can obtain the rest of the components. But, here, few terms were computed and the asymptotic solution is given by the following:

$$\begin{aligned}
 u(x, t) &= u_0(x, t) + u_1(x, t) + u_2(x, t) + u_3(x, t) + \dots, \\
 v(x, t) &= v_0(x, t) + v_1(x, t) + v_2(x, t) + v_3(x, t) + \dots. \tag{30}
 \end{aligned}$$

4.1. Numerical Solutions. The following figures show the graphical representation of the approximated solution of the system of the time-fractional coupled-Korteweg-de-Vries equations for $\lambda = 1, a = b = 1$.

Note that the below figure show that the coupled solution of KDV equation is not only the function of time and space but also an increasing function of the fractional order derivative, which are α and β . The approximate solution of main problem has been depicted in Figures 1, 2, 3, and 4 which is plotted in Mathematica according to different α and β values.

It is important to note that if $\alpha = \beta, a = 1,$ and $b = 3,$ the exact solution of the coupled-KDV equations is given as

$$\begin{aligned}
 u(x, 0) &= \frac{\lambda}{a} \left(\operatorname{sech} \left(\frac{1}{2} \sqrt{\frac{\lambda}{a}} x - \lambda t \right) \right)^2, \\
 v(x, 0) &= \frac{\lambda}{\sqrt{2a}} \left(\operatorname{sech} \left(\frac{1}{2} \sqrt{\frac{\lambda}{a}} x - \lambda t \right) \right)^2. \tag{31}
 \end{aligned}$$

Thus, to test the accuracy of the relatively new analytical technique, we represent in Table 1 the numerical values of the approximate and the exact solutions and the results obtained in [20].

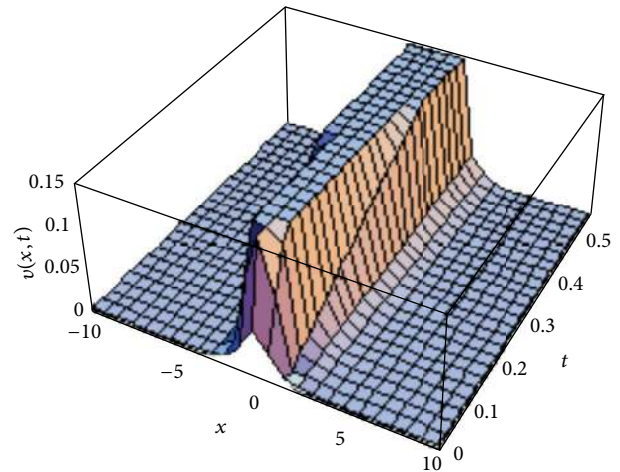

FIGURE 1: Approximate solution for $\alpha = 0.75$ and $\beta = 0.45$.

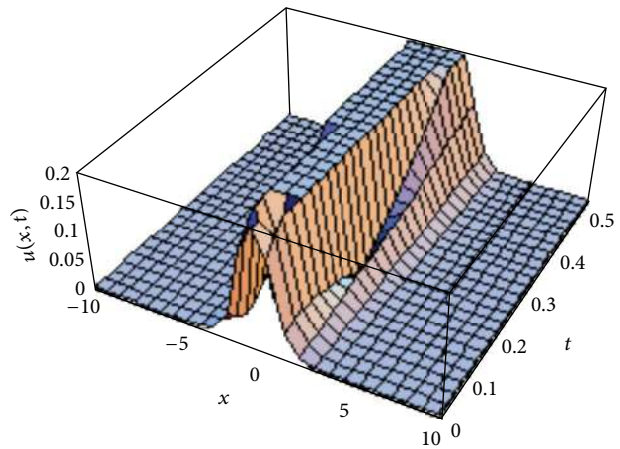

FIGURE 2: Approximate solution for $\alpha = 0.75$ and $\beta = 0.45$.

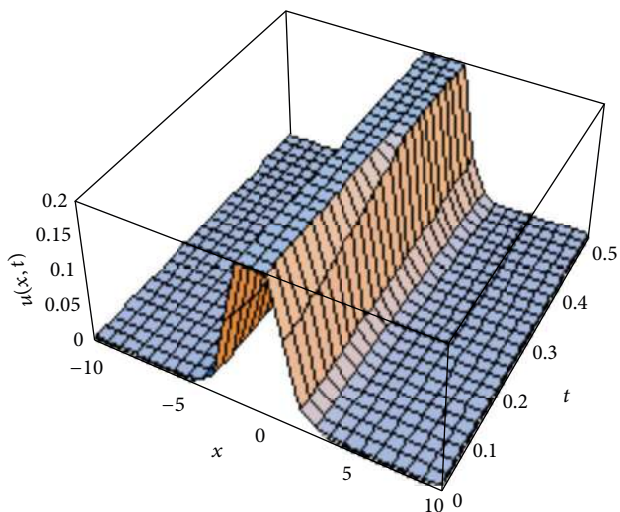

FIGURE 3: Approximate solution for $\alpha = 1$ and $\beta = 0.9$.

TABLE 1: Numerical values of the approximate, exact solutions and the results obtained in [20, 21].

x	t	$u(x, t)$ exact	$u(x, t)$ approximate	[20]	Error for [20]	Error approx
-10	0.1	0.000164305	0.000164334	0.000164384	2.99039×10^{-8}	2.95039×10^{-8}
	0.2	0.00014867	0.000148901	0.000148991	2.33335×10^{-7}	2.30335×10^{-7}
-5	0.1	0.0240923	0.0240963	0.02409673	3.96592×10^{-6}	3.93592×10^{-6}
	0.2	0.0218248	0.0218556	0.02185586	0.0000338049	0.0000308049
5	0.1	0.0240923	0.0240963	0.02409653	3.97592×10^{-6}	3.93592×10^{-6}
	0.2	0.0218248	0.0218556	0.02185576	0.0000378049	0.0000308049
10	0.1	0.000164305	0.000164334	0.000164344	2.96039×10^{-8}	2.95039×10^{-8}
	0.2	0.00014867	0.000148901	0.000148931	2.37335×10^{-7}	2.30335×10^{-7}
x	t	$v(x, t)$ exact	$v(x, t)$ approximate	[20]	Error for [20]	Error
-10	0.1	0.000116181	0.000116202	0.000116232	2.18624×10^{-8}	2.08624×10^{-8}
	0.2	0.000105126	0.000105289	0.000105259	1.64872×10^{-7}	1.62872×10^{-7}
-5	0.1	0.170358	0.0170386	0.0170387	2.88312×10^{-6}	2.78312×10^{-6}
	0.2	0.0154325	0.0154542	0.0154552	0.0000287824	0.0000217824
5	0.1	0.170358	0.0170386	0.0170389	2.98312×10^{-6}	2.78312×10^{-6}
	0.2	0.0154325	0.0154542	0.0154562	0.0000247824	0.0000217824
10	0.1	0.000116181	0.000116202	0.000116252	2.09624×10^{-8}	2.08624×10^{-8}
	0.2	0.000105126	0.000105289	0.000105299	1.72872×10^{-7}	1.62872×10^{-7}

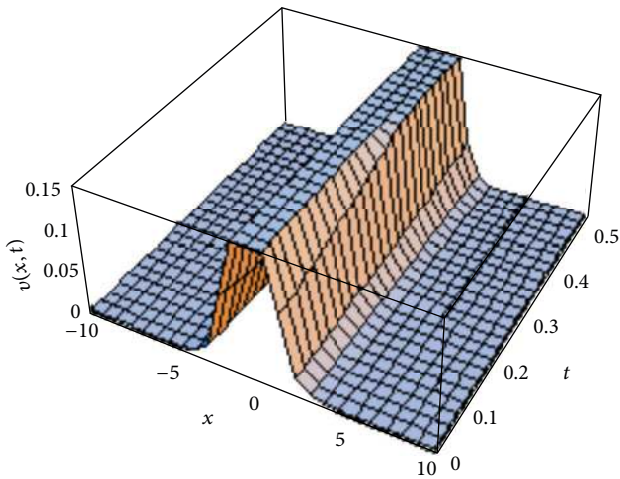

FIGURE 4: Approximate solution for $\alpha = 1$ and $\beta = 1$.

Table 1 comparison shows that the solutions obtained in this paper are more accurate than those obtained in [20].

5. Conclusions

We derived approximated solutions of nonlinear fractional-coupled KDV equations using the relatively new analytical technique, the HDM. We presented the brief history and some properties of fractional derivative concept. It is demonstrated that HDM is a powerful and efficient tool of FPDEs. In addition, the calculations involved in HDM are very simple and straightforward. Comparing the methodology HDM to HPM, ADM [25], VIM, and HAM have the advantages. Disparate the ADM, the HDM is free from the need to use the Adomian polynomials. In this method, we do not need the

Lagrange multiplier, correction functional, stationary conditions, or calculating heavy integrals, as the solutions obtained are noise free [26], which eliminate the complications that exist in the VIM. In contrast to the HAM, this method is not required to solve the functional equations in iteration since the efficiency of HAM is very much dependant on choosing auxiliary parameter. In contract to HPM, we do not need to continuously deform a difficult problem to another that is easier to solve. We can easily conclude that the homotopy decomposition method is a well-organized analytical method for solving exact and approximate solutions of nonlinear fractional partial differential equations.

References

- [1] M. Kurulay, A. Secer, and M. A. Akinlar, "A new approximate analytical solution of Kuramoto-Sivashinsky equation using homotopy analysis method," *Applied Mathematics & Information Sciences*, vol. 7, no. 1, pp. 267–271, 2013.
- [2] K. B. Oldham and J. Spanier, *The Fractional Calculus*, vol. 111 of *Mathematics in Science and Engineering*, Academic Press, New York, NY, USA, 1974.
- [3] I. Podlubny, *Fractional Differential Equations*, vol. 198 of *Mathematics in Science and Engineering*, Academic Press, San Diego, Calif, USA, 1999.
- [4] A. A. Kilbas, H. M. Srivastava, and J. J. Trujillo, *Theory and Applications of Fractional Differential Equations*, vol. 204 of *North-Holland Mathematics Studies*, Elsevier Science B.V., Amsterdam, The Netherlands, 2006.
- [5] I. Podlubny, *Fractional Differential Equations*, vol. 198 of *Mathematics in Science and Engineering*, Academic Press, San Diego, Calif, USA, 1999.
- [6] M. Caputo, "Linear models of dissipation whose Q is almost frequency independent—II," *Geophysical Journal International*, vol. 13, no. 5, pp. 529–539, 1967.

- [7] A. A. Kilbas, H. M. Srivastava, and J. J. Trujillo, *Theory and Applications of Fractional Differential Equations*, vol. 204 of *North-Holland Mathematics Studies*, Elsevier Science B.V., Amsterdam, The Netherlands, 2006.
- [8] K. S. Miller and B. Ross, *An Introduction to the Fractional Calculus and Fractional Differential Equations*, A Wiley-Interscience Publication, John Wiley & Sons, New York, NY, USA, 1993.
- [9] S. G. Samko, A. A. Kilbas, and O. I. Marichev, *Fractional Integrals and Derivatives: Theory and Applications*, Gordon and Breach Science, Yverdon, Switzerland, 1993.
- [10] G. M. Zaslavsky, *Hamiltonian Chaos and Fractional Dynamics*, Oxford University Press, Oxford, UK, 2008.
- [11] A. Atangana, "Numerical solution of space-time fractional derivative of groundwater flow equation," in *International Conference of Algebra and Applied Analysis*, pp. 1–20, June 2012.
- [12] R. Hirota and J. Satsuma, "Soliton solutions of a coupled Korteweg-de Vries equation," *Physics Letters A*, vol. 85, no. 8–9, pp. 407–408, 1981.
- [13] Z. M. Odibat and S. Momani, "Application of variational iteration method to nonlinear differential equations of fractional order," *International Journal of Nonlinear Sciences and Numerical Simulation*, vol. 7, no. 1, pp. 27–34, 2006.
- [14] K. S. Miller and B. Ross, *An Introduction to the Fractional Calculus and Fractional Differential Equations*, A Wiley-Interscience Publication, John Wiley & Sons, New York, NY, USA, 1993.
- [15] I. Podlubny, *Fractional Differential Equations*, vol. 198 of *Mathematics in Science and Engineering*, Academic Press, San Diego, Calif, USA, 1999.
- [16] S. G. Samko, A. A. Kilbas, and O. I. Marichev, *Fractional Integrals and Derivatives*, Gordon and Breach Science, Yverdon, Switzerland, 1993, translated from the 1987 Russian original.
- [17] G. Jumarie, "On the representation of fractional Brownian motion as an integral with respect to $(dt)^a$," *Applied Mathematics Letters*, vol. 18, no. 7, pp. 739–748, 2005.
- [18] G. Jumarie, "Modified Riemann-Liouville derivative and fractional Taylor series of nondifferentiable functions further results," *Computers & Mathematics with Applications*, vol. 51, no. 9–10, pp. 1367–1376, 2006.
- [19] A. Atangana and J. F. Botha, "Analytical solution of the groundwater flow equation obtained via homotopy decomposition method," *Journal of Earth Science & Climatic Change*, vol. 3, no. 2, p. 115, 2012.
- [20] M. Merdan and S. T. Mohyud-Din, "A new method for time-fractional coupled-KDV equations with modified Riemann-Liouville derivative," *Studies in Nonlinear Science*, vol. 2, no. 2, pp. 77–86, 2011.
- [21] S. A. El-Wakil, E. M. Abulwafa, M. A. Zahran, and A. A. Mahmoud, "Time-fractional KdV equation: formulation and solution using variational methods," *Nonlinear Dynamics*, vol. 65, no. 1–2, pp. 55–63, 2011.
- [22] J.-H. He, "Homotopy perturbation technique," *Computer Methods in Applied Mechanics and Engineering*, vol. 178, no. 3–4, pp. 257–262, 1999.
- [23] M. Matinfar and M. Ghanbari, "The application of the modified variational iteration method on the generalized Fisher's equation," *Journal of Applied Mathematics and Computing*, vol. 31, no. 1–2, pp. 165–175, 2008.
- [24] Y. Tan and S. Abbasbandy, "Homotopy analysis method for quadratic Riccati differential equation," *Communications in Nonlinear Science and Numerical Simulation*, vol. 13, no. 3, pp. 539–546, 2008.
- [25] J. Biazar, *Solving system of integral equations by Adomian decomposition method [Ph.D. thesis]*, Teacher Training University, Iran, 2002.
- [26] A. Atangana, "New class of boundary value problems," *Information Sciences Letters*, vol. 1, no. 2, pp. 67–76, 2012.



Hindawi

Submit your manuscripts at
<http://www.hindawi.com>

