

The why of adaptive protections in modern electrical networks

El porqué de las protecciones adaptativas en las redes eléctricas modernas

Juan M. Guardiola¹, Eduardo Gómez-Luna², Eduardo Marlés-Sáenz³, and Jorge de la Cruz⁴

ABSTRACT

Electrical networks are evolving and taking on more challenges as the inclusion of renewable energy and distributed generation units increase, specially at distribution levels. Big trends of generating electricity with alternative and renewable resources has promoted the formation of distribution networks subsystems or micro grids, capable of supplying their own electric demand and to export energy to the interconnected system, if necessary. However, the effects of these generation units into the network and into the microgrid as well are many, as harmonic distortion, voltage flickers and especially in electrical protections.

This paper provides an overview about implementation of renewable energy and distributed generation worldwide, as well as an introduction to microgrids concept and its main impacts and challenges into the electric systems. Finally, the main impacts of microgrid on protection equipments are presented at a distribution level, being adaptive protections one of the solutions to the dynamic changes of the electric system.

Keywords: Distributed generation, Distributed energy resources, Smart grids, Microgrids, Adaptive protections.

RESUMEN

Las redes eléctricas están evolucionando y asumiendo más retos conforme incrementa la inclusión de energías renovables y unidades de generación distribuida, especialmente a niveles de distribución. La gran tendencia a generar electricidad con fuentes alternas y renovables ha impulsado la formación de subsistemas de distribución o micro redes, capaces de suplir su propia demanda eléctrica y exportar energía al sistema interconectado de ser necesario. Sin embargo, los efectos de la inclusión de estas unidades de generación sobre la red eléctrica y la misma micro red son varios, como distorsión armónica, oscilaciones de tensión y sobre todo, sobre las protecciones eléctricas.

Este artículo brinda un panorama actual de la implementación de energías renovables y generación distribuida a nivel mundial, así como una introducción al concepto de micro redes y sus principales impactos y desafíos en el sistema eléctrico. Finalmente, se presentan los principales impactos de las micro redes sobre los equipos de protección a nivel de distribución, siendo las protecciones eléctricas adaptativas una de las soluciones a los cambios dinámicos del sistema eléctrico.

Palabras clave: Generación distribuida, Recursos de energía distribuidos, Redes inteligentes, Micro redes, Protecciones adaptativas.

Received: September 09th, 2018

Accepted: June 21st, 2019

Introduction

Nowadays global energy is based on fossil fuels in approximately a 79,5%, while nuclear energy and renewables contribute with 2,3% and 18,2% respectively. Within electricity generation with renewable sources without traditional biomass (10,4% of the previous 18,2%), contributions are considerably low, only 3,7% corresponds to a hydraulic source, while solar, wind and geothermal represent the 1,7%, biofuels 0,9% and the remaining 4,1% represents biomass and geothermal heat. Data estimate at the end of 2016 (Renewable Energy Policy Network for the 21st Century (REN21), 2018).

Figure 1 illustrates the global consumption based in primary energies such as oil and coal between 1965 and 2017, reaffirming the predominance of fossil fuels as the energetic foundation worldwide. The generation of electricity with renewable and alternative sources has increased gradually in

the world, for example, from 2 017 GW of the global capacity in 2016 to 2 195 GW in 2017, data that includes hydroelectric

¹Electrical Engineering Undergraduate Student, Universidad del Valle, Colombia. E-mail: juan.guardiola@correounivalle.edu.co

²Electrical Engineer, Universidad del Valle, Colombia. Ph.D. Electrical Engineering, Universidad del Valle, Colombia. Affiliation: GITICAP research group director, Potencia y Tecnologías Incorporadas S.A., Colombia. E-mail: eduardo.gomez@pti-sa.com.co.

³Electrical Engineer, Universidad del Valle, Colombia. M.Sc. Electrical Engineering, Universidad del Valle, Colombia. Affiliation: GRALTA research group, Universidad del Valle, Colombia. E-mail: eduardo.marles@correounivalle.edu.co.

⁴Electrical Engineer, Universidad Nacional de Colombia, Colombia. Affiliation: Master Student, Universidad Nacional de Colombia, Colombia. E-mail: jdel@unal.edu.co

How to cite: Guardiola, Juan M., Gómez-Luna, Eduardo, Marlés-Sáenz, Eduardo, and de la Cruz, Jorge (2019). The Why of Adaptive Protections in Modern Electrical Networks. *Ingeniería e Investigación*, 39(2), 58-68. DOI: 10.15446/ing.investig.v39n2.74786



Attribution 4.0 International (CC BY 4.0) Share - Adapt

generation, without this type of source the global increased has been from 922 GW to 1 081 GW (Renewable Energy Policy Network for the 21st Century (REN21), 2018).

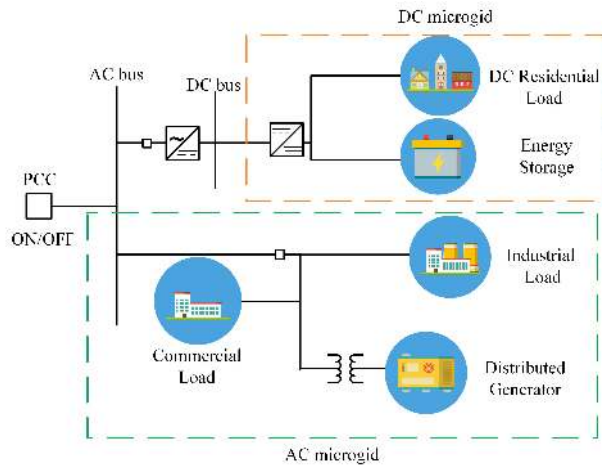

Figure 1. Shares of global primary energy consumption by fuel. Percentage.

Source: (BP, 2018)

Implementation of units based in renewable and alternative energies of low power capacity, and usually connected to a feeder, substation or near to the user, are known as “distributed generation units” (DG’s) or “distributed energy resources” (DER’s), because they are often distributed along the transmission and distribution system (Gers & Viggiano, 2016; J. P. Nascimento, Brito, & De Souza, 2016; Yang & Wang, 2015). In Colombia, for example, activities as generation of electricity can be done for supplying users own demand or near consumption centers by being connected to the local distribution system or SLD by the Spanish words (Comisión de Regulación de Energía y Gas. CREG, 2018).

The main distributed energy technologies implemented worldwide are: solar photovoltaics (PV), wind energy, small hydroelectric plants, combined heat and power (CHP), solar thermal, gas turbines and diesel generators. Distributed generation units are characterized by having synchronous or asynchronous generators, usually with rated capacities below 50 MW and voltages in the range of 240 V and 34,5 kV; also, DG’s can be inverter based generators or IBDC’s applied for PV systems, for example (Gers & Viggiano, 2016; Gönen, 2014; Horowitz & Phadke, 2014; Muda & Jena, 2017a; Singh, 2013). A review of characteristics of energy storage systems for microgrids like batteries, supercapacitors, fuel cells, superconducting magnetic energy storage and others are also discussed in (Guacaneme, Velasco, & Trujillo, 2014).

This paper is divided as follows. An introduction to the concept of microgrids and their integration into power systems is presented; the main impacts and challenges of microgrids in distribution systems; impacts of microgrids in electrical protections and finally, and introduction to the adaptive protections concept in microgrids.

Microgrids integration in electrical power systems

According to (Gupta, Varshney, Swathika, & Hemamalini, 2016), the need for an alternative power generation system presents an opportunity for the on-site energy generation, in vicinity to the place of consumption, which aims to administrate and/or control the associated loads and generation in a better way. In this way, the integration of generation units like batteries and control systems, connected to the main grid through a point of common coupling or PCC. This combination of small units or distributed generation, energy storage and control systems at distribution level, form a distribution network subsystem, also known as a microgrid (MG) (L. L. Do Nascimento & Rolim, 2013; Gupta et al., 2016; Khederzadeh, 2012; Tello-maita & Marulanda-guerra, 2017; Tummasit, Premrudeepreechacharn, & Tantichayakorn, 2016).

MG’s are low and medium voltage systems in AC, DC or both, single or three-phase, which operates connected to the main grid, usually referred to as a macrogrid; or disconnected from it (island mode). The last mode of operation can be presented due to a system disturbance in the main grid or by a controlled action. The MG is then disconnected through the PCC (see Figure 2) (Monadi, Gavrilita, Luna, Candela, & Rodriguez, 2017), (Hosseini, Abyaneh, Sadeghi, Razavi, & Nasiri, 2016). Under a MG steady state condition and connected to the main grid, both, the main grind and MG supply all the system loads by burden sharing, especially in peak demand (Kroposki et al., 2008), (Che, Khodayar, & Shahidehpour, 2014; Hosseini et al., 2016; Ustun, Ozansoy, & Zayegh, 2012). On the other side, while working on island mode, MG loads are totally supplied by the DG units and energy storage systems until the MG is reconnected to the main network, otherwise, these units must have the power capacity to maintain the generation-demand balance (L. L. Do Nascimento & Rolim, 2013), (Laaksonen, Hannu; Ishchenko, Dmitry; Oudalov, 2014).

Additionally of being a distribution level network of low or medium voltage, MG’s have different characteristics and properties according to their main feeders (Hooshyar & Iravani, 2017):

Urban MG’s: feeders are located in a populated or concentrated industrial area and generally densely loaded. Imbalance level is very low and the short circuit ratio at the PCC is approximately 25 (ratio of the short circuit capacity by the main grid to the total generation capacity of the MG). As a consequence, during it grid-connected mode, voltage and frequency are dictated by the macrogrid.

Rural MG’s: feeders are placed in low populated areas, where laterals are long from the main trunk, thus, have very low load density. MG imbalance can be significant, with high impact on voltage by the DG’s.

Off-grid MG's: are located in remote areas with no possibility of connection to the macrogrid and transmission lines due to geographical conditions. This type of MG always operates in island mode. Despite not having a PCC, they are considered a MG because they fulfill the basic requirements mentioned above and other characteristics like such as voltage regulation, voltage flickers and harmonic distortion, also met in common MG's.

At this moment, several MG's have been implemented worldwide in distribution systems, as an example, consider the MG installed in the biggest island of Finland, Hailuoto Island. A pilot medium voltage MG was installed to operate in islanding mode, which includes a portion of 20 kV overhead feeder, with a wind turbine of 0,5 MW and a diesel generator of 1,5 MW (Laaksonen, Hannu; Ishchenko, Dmitry; Oudalov, 2014). In Thailand, a 22 kV distribution feeder supplies electric power to the remote area of Mae-Sariang city, where a MG is located from the main grid in approximately 106 km. Several loads of 1 MW, 0,9 MW and 1,3 MW are supplied by a hydro generator of 1,5 MVA, a solar system of 4 MW, a diesel generator of 7,5 MVA and battery storage of 3 MW (Tummasit et al., 2016). Other case of an implementation of a MG was reported by (Mahat, Chen, Bak-Jensen, & Bak, 2011), where the distribution network is located in Aalborg, Denmark and is formed by three wind turbines of 630 kW, a CHP and three gas turbines.

In a more regional approach, in Latin America an isolated MG, Huatacondo microgrid located in Atacama Desert, Chile. The microgrid consists on a 150 kW diesel generator, 22 kW tracking solar PV systems, a 3 kW wind turbine, a 170 kWh battery and an energy management system, which minimize the operation costs by providing the set-point for the generation units. In (Palma-Behnke, Ortiz, Reyes, Jiménez-Estévez, & Garrido, 2011) a social SCADA approach was proposed to guarantee an optimal energy consumption based on the community requirements. Also in (Bonilla-Gómez, 2017) a microgrid design was proposed in the community of Santa Elena, Costa Rica. Other microgrid projects around the world are summarized and their main characteristics, such as size, type of generation unit, energy storage devices, load and control are provided in (Mina, 2017).

Design methodologies for off-grid microgrids in Colombia, and power systems optimization models considering integration of distributed energy resources are exposed by (Correa-Henao & Rojas-Zerpa, 2017; Garzón-Hidalgo & Saavedra-Montes, 2015; Meneses, 2011; Tello-maita & Marulanda-guerra, 2017)

Several MG's have been modeled through simulation software's, which is a widely used tool for power systems analysis and for the MG itself, due to its integration in distribution networks. As evidenced by (J. P. Nascimento et al., 2016), two DG's were connected to the IEEE 13-node network for a protection analysis by real-time simulation (RTS). Similarly, PSCAD (Power System Computer-Aided Design) was used to simulate transient events in a 20 kV MG with two 1,5 MVA generators at 10 km and 11 km

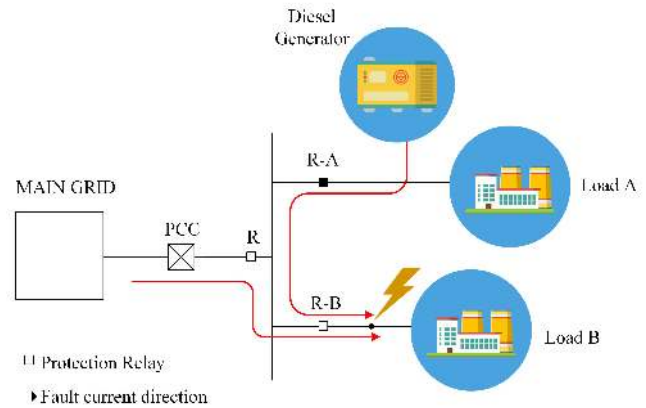

Figure 2. AC/DC microgrid with connected and island mode of operation.

Source: Authors

from the main feeder, DG's converters were simulated as well. A three-phase fault was analyzed in islanded and grid-connected mode of operation, connected to a 110 kV system (S. Voima, Laaksonen, & Kauhaniemi, 2014). Hereon, the term "fault" is going to be refers to a three-phase short circuit fault specifically.

One of the main reasons of studying MG's, besides its great application potential, is to improve its behavior, reliability and reducing impacts for both, the power system and the users. As mentioned before, MG's are formed by generation and storage units, that is why, is important to establish an adequate control system in each element in the MG. In addition, with a trend to growth in DC MG's, there is more implementation of electronic converters or VSC's (Voltage Source Converters) and other power electronic devices, which are one of the main challenges that DG's and MG's have to deal with to become a more reliable and promising distribution network subsystem. Challenges that increase with new technologies and new ways of generating electricity (Hosseini et al., 2016; Monadi et al., 2017).

MG's Impacts and challenges in distribution systems

The traditional concept of a power system and more specifically, a distribution system is conceived to have radial operation with passive nature elements, i.e., a system that is characterized for generating electricity with some high power generators and are the only sources of power in all the network to supply the loads or customers, harnessing and consuming the energy (Ishchenko, Oudalov, & Stoupis, 2012).

In accordance with this perspective, power flow is always unidirectional, from the generation units to feeders and then, the loads (Che et al., 2014). Integration of DG's at the same level as users implies a change of scheme with respect to

the conventional power flow, which becomes bidirectional. It is important to notice that power systems had not been designed to consider generation units along distribution networks (Gupta et al., 2016; Luna & Parra, 2011). As a consequence, technical changes in the network due to the DG's characteristics have been presented, as the dependency of the resource and time variable availability of the energy sources (Gers & Viggiano, 2016). Being reflected in dynamic and intense changes of the grid topology, as a way to satisfy generation-demand balance (Shih & Enriquez, 2014). It is understood by topology as the operational mode of the system (islanded mode or grid-connected mode), with different grid configurations (radial, looped, meshed or a combination) (Hosseini et al., 2016).

The benefits achieved with DG's at a distribution level are many, as technical, economic and environmental, which are not the main focus of this paper. However, reaching optimal conditions to obtain those benefits is a hard task as it strongly depends on the DG reliability, the energy source variability, size and total power capacity of the DG and being at the proper location. Also, some standard control, installation and maintenance conditions have to be met, on the contrary, the minimal operative criterion won't be achieved and the integration of the DG's will impact the electrical system negatively (Barker & De Mello, 2000).

An important aspect is the behavior of the MG in the presence of any disturbance, which depending on their impact, can be reflected in small signal stability, transient or voltage stability in the MG as well. Some of the main reasons of instability or security issues are the occurrence of frequent faults, load/generation variations, load dynamics and insufficient control schemes in the DG's as explained by (Teimourzadeh, Aminifar, & Davarpanah, 2017). If any kind of faults occurred inside the MG or in the main grid are not cleared in a short time, it is that the MG presents frequency or voltage instability and then, a blackout may take place while operating in islanding mode, being unable to supply all the loads present in the MG (Li, Li, & Zhou, 2015). Therefore, microgrid stability must be assessed in the post-contingency period, nonetheless, due to the great complexity of power systems and variety of components, high computational resources are required (Schweickardt, Manuel, & Alvarez, 2013).

Contrary with conventional networks where synchronous generators have a fundamental role and their stability can be studied from the rotor-angle, frequency and voltage point of view, MG's implement a widely number of IBDG's, being the characteristics and dynamics of the MG different with respect to conventional networks. This is why, MG's are not fully compatible with traditional analysis methods, being a case of study nowadays (Shuai et al., 2016). In this way, factors as the load dynamics, low inertia constant in generators, fault frequency and many others are the reasons of security issues in MG's (Teimourzadeh et al., 2017).

According to (Barker & De Mello, 2000; Bhise, Kankale, & Jadhao, 2017; Mozina, 2010), impacts and challenges of DG's and MG's in the electrical system can be reflected in six fundamental topics, as is described as follows:

Voltage regulation

Voltage regulation is made to maintain adequate voltage levels for the users, by using tap changers in power transformers at substations; line regulators and capacitor bank at feeders.

The criterion for voltage regulation is based on radial systems with passive elements, therefore, integration of DG's may affect stability and efficiency of such action by modifying the conventional power flow characteristics mentioned above. Nonetheless, in some cases, DG's may contribute to a continuous voltage regulation by the contribution of reactive power to the grid, improving voltage at its own and neighboring busbars. Also defined as a localized or regional control of voltage output (Arango, Carvajal, & Arango, 2011).

With aims to reduce or to determine the impacts of DG's integration, is important to consider dimensions and location of the generation unit, characteristics of the regulation element and associated transmission line. For example, by not considering the location point of the DG's, if they are located in a system with a common transformer, is possible to have a voltage increased or drop in the secondary-side of the transformer and the regulator device might not be able to detect such event if the DG is located downstream the regulator. Then, electrical devices may be damaged due to modification in the equivalent load seen by the regulator or compensator. To obtain the maximum advantages of DG's, they must be located in the proper site, to not interfere with the distribution network and to reduce their limitations about power injection (Grisales Noreña, Restrepo Cuestas, & Jaramillo Ramirez, 2017; Lepadat, Helerea, Abagiu, & Mihai, 2017; López-Lezama, Buitrago, & Villada, 2015; Narváez, López-Lezama, & Velilla, 2015).

In (Granja, de Souza, Sobrinho, & Santos, 2018), the behavior and some solutions about power quality at the PCC of a MG are described, such as control strategies for voltage imbalance due to nonlinear and unbalance loads; the use of a series-parallel converter arrange to control the voltage imbalance and current demand caused by a fault in the network, also a closed-loop strategy for power quality are mentioned as well. The authors studied the power quality at the PCC of a low voltage grid located in Colombia with a photovoltaic system at the *Universidad de Ibagué*, analyzing the system efficiency and a methodology for assessment of energy quality was proposed.

Losses

Since is wanted to take the most of DG's, this implies to reduce electrical losses at its minimum. Here the location of generation units plays a fundamental role to achieve this objective, being comparable with shunt capacitors location for reactive compensation. The difference is that DG's have the capacity of injecting both, active and reactive power to the network, in a power factor range between 0,85 and 1,00, leading and lagging if they are inverter-based generators.

Generation units with power capacities near 10% and 20% of their feeder total capacity can reduce losses notably if they are at the proper site. Considering that most of the DG's are user-owned units and not from the grid operator, there is no strict control about the DG's installation. Therefore, if feeder limits and capacities are not taken into account, thermal limits of conductors and DG's can be exceeded, increasing the system losses, even though if they are at the right location.

Voltage flicker

Voltage flicker occurs mainly during the generators start-up, fluctuations in output voltage as usually occurs with PV systems and wind energy due to its resource variations, or significant events in DG's that affects voltage at the feeders. Also, voltage flicker and power oscillation can occur due to any disturbance in the generator shaft torque and due to generation units constructive asymmetries and may vary with the variation of the load as well (Armas teyra & Alvinn, 2013).

These flickers can be mitigated by reducing voltage at the generators start-up, a more rigorous and robust synchronization of synchronous machines and implementing power inverters to control inrush currents and soft starter applications, for example.

Harmonic distortion

Harmonics are introduced by DG's, their design type and power electronic devices associated with them as power inverters, which are used to convert DC signals into AC signals at the output.

The main consequences of harmonics into the network are the high distortion levels, capacitors bank resonance and heating of electrical equipment. For these reasons, voltage and currents harmonics control requirements have to be met in accordance with the standards, IEEE 519 for example. As indicated in (IEEE, 2014), the total harmonic distortion levels (THD) allowable for some voltage ranges are defined at the measurement point.

Table 1. Voltage distortion limits - IEEE 519

Bus Voltage at PCC	Individual harmonic (%)	Total harmonic distortion THD (%)
$V \leq 1,0$ kV	5,0	8,0
$1,0$ kV $< V \leq 69$ kV	3,0	5,0
69 kV $< V \leq 161$ kV	1,5	2,5
161 kV $< V$	1,0	1,5-2

Source: (IEEE, 2014)

In (Khaledian, Vahidi, & Abedi, 2014) an experimental microgrid is simulated to study the impacts of different harmonics distortions, and a control strategy is tested in order to reduce the THD in the source and other load sides.

Generators and transformers grounding system

Generators must be applied with an associated transformer and a solid grounding arrangement compatible with the electrical system, in order to avoid voltage swells, over voltages and possible damage in electrical equipment and generation units.

Distribution systems usually uses a four-wire-multigrounded-neutral system because this configuration allows to limit the voltage rise on unfaulted phases about to 125% and 135% of the prefault conditions for single line to ground faults. On the contrary, while not having a solid grounding system, voltage can increase about to 173% of its prefault condition on the unfaulted lines for an undefine period of time, and could be dangerous if the DG in island mode of operation continues to serve a group of customers (Barker & De Mello, 2000). Also, a high-resistance grounding system can be implemented for a single DG unit, or a low-resistance system for several units connected in parallel or for auxiliary transformers, nonetheless, this configurations allow high magnitude fault currents (Torres, Marlés, & Caicedo, 2018).

To limit overvoltage's the abovementioned configurations can be applied, also different transformers arrangements or vector groups and finally, the use of the transformer saturation characteristics as described by (Barker & De Mello, 2000) and (Mozina, 2010).

Short circuit level

One of the most notable impacts over the electrical network and electrical devices is the short circuit level variation. Penetration of DG's, independently of their size or the operational mode of the MG, rises the magnitude of the fault current during a contingency.

All generation units contribute to load and short circuit current in the system (Urbina, 2015). In the case of IBDG units, fault current contributions are about 2 p.u and 3 p.u (per unit) of the nominal current, as indicated by (Muda & Jena, 2017b). Meanwhile synchronous and asynchronous generators have more considerable contributions depending on their location, size and number of units (Singh, 2013), (Coffele, Booth, & Dyśko, 2014).

Considering the fact that most MG's are DC types or may have many IBDG's, hence, have dc-link capacitor banks at their PCC or busbars. At the occurrence of a fault, the dc-link capacitor discharges causing a voltage drop at the busbar; immediately, the stored energy in the cable inductance is also discharged by the free-wheel diodes of the power inverters or VSC's, which leads the VSC to operates as an uncontrolled full-bridge rectifier because the main switches of the VSC's turn off to protect them against an overcurrent; then, the fault will be fed from the AC side of the grid. Therefore, there are three main sources for fault current during a fault in a MG besides the contributions from the elements in the AC MG that does not use converters; dc-link capacitors discharge current; cable inductance discharge through the free-wheel diodes; and the AC grid current.

To avoid affecting the VSC's and other equipments from a fault, the AC circuit breakers should operate in faster, at the same time, electrical protection should act at the moment of the dc-link capacitors discharge and then, prevent the voltage drop and fault current flow to the VSC's. Differential and communication-assisted protective methods have been proposed as a fast and reliable solution, because they more sensitive methods than overcurrent and are able to detect faults and to disconnect DG's and DER's at a proper time (Monadi et al., 2017).

Taking into account the consequences that a fault will lead in a distribution network with an integrated MG, is important to consider the impacts and functions of protective devices at the distribution level in the case of short circuit faults and the possible solutions proposed at this moment, due to the relevance of electrical equipment not only for the power system, but for the customers.

Impacts of MG's in electrical protections

As (Ramos, Bernardon, & Comassetto, 2013) reiterates, distribution networks protective devices must be effective and selective, this is, must isolate the faulted zone in a secure way and interrupting a minimum quantity of customers. All the impacts abovementioned have an impact over the electrical system and protective devices present in the MG, leading to a malfunction of electrical equipments and then, unnecessary losses of generation units and system's security and reliability (Almeida, E. Leite, H. Silva, 2014).

Nowadays, MG's have to cope with the impacts of integration of DG's in an electrical system that have not been designed for electricity generation at distribution or a customer level, that counts with unidirectional protective devices and do not consider a dynamic subsystem. According with several authors, (Almeida, E. Leite, H. Silva, 2014; Che et al., 2014; de las Casas & Boza, 2009; Hosseini et al., 2016; Urbina, 2015) the main challenges that MG's presents in conventional systems are at a protective level, some of them are as follows:

False tripping

At the occurrence of a fault at any point of the system, DG protections may act if current contribution of the unit is high enough, in spite of the faulty zone being located in another neighboring feeder, causing an unnecessary tripping of the unit even of the MG. This is also known as *sympathetic tripping* as illustrated by Figure 3, where the protective relay R-A is tripped by the DG's contribution for a fault occurred near R-B.

Blindness of protection

By connecting a DG or a DER into the network, the equivalent impedance seen from the feeder is increased and then, fault current is reduced. This affects the protective devices as relays with overcurrent characteristics because of their dependency of the system impedance, therefore, are unable to detect the fault for that they have been set for.

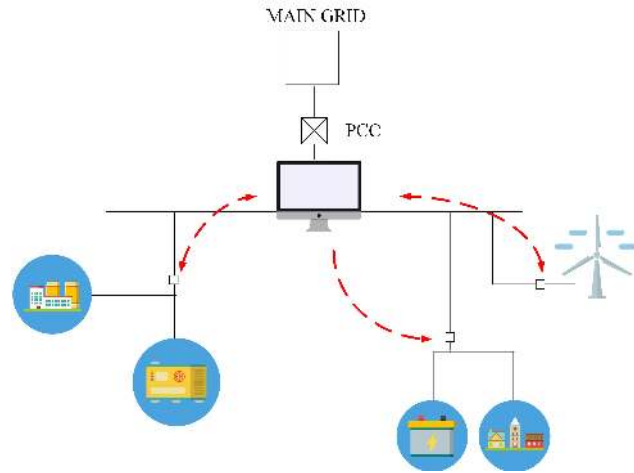

Figure 3. False tripping in a power system with an integrated MG.
Source: Authors

Unsynchronized reclosing

Synchronism of DG's with the grid has to be taken into account by the recloser, otherwise serious damages can be caused, affecting sensitive equipments connected into the grid and the DG as well.

Miscoordination

Most of distribution systems use overcurrent protective devices, such as fuses, in the case the fault current is significantly less than the equipments rated value they might not operate correctly because their filament won't melt and then, the circuit or faulty zone is not going to be isolated, leaving the fault still present in the system as the relays and reclosers won't be able to detect it either (Khederzadeh, 2012).

In addition, relay-fuse coordination is done according with the possible fault paths and in a MG, by including several DG's and different topologies possibilities, fault paths may be many (Piescirovsky & Schulz, 2017). In case of recloser-fuse coordination, by varying the fault current according with system's topologies, the recloser and fuse may not detect the anomalies presented, even operate improperly (Su, Liu, Chen, & Hu, 2014).

Many possible solutions have been proposed to maintain protective coordination in conventional distribution networks to guarantee system's reliability. Some proposals have been implementing a fly wheel as an storage system and generation units with high fault current contribution in the MG as a way to increase fault current in islanding mode for the overcurrent devices to be able to detect the fault (Che et al., 2014; L. L. Do Nascimento & Rolim, 2013; Mahat et al., 2011). At the time of changing from grid-connected mode to island mode, the relay protective scheme changes from overcurrent to distance (S. Voima et al., 2014). Implementing differential relays and voltage transformers to detect faults resistance is another alternative, nevertheless,

lots of information have to be transferred between protections devices and data concentrators, also, a complex software is needed (Ehrenberger, 2015). Is proposed by (Bhattarai, Bak-Jensen, Chaudhary, & Pillai, 2015) to disconnect all DG's and DER's once a fault have been detected in the MG to maintain protection coordination settings.

As it has been mentioned earlier, the integrations of DG's modify the system's existing conditions for protective devices. Settings and coordination can be set for a MG in islanding mode of operation, but at the moment it gets connected to the main grid these settings must be replaced for those according with the new operational characteristics of the MG, including the macrogrid and/or the effects of contingencies in the network. A fixed or static group of settings becomes a more complex decision due to the many possibilities or changes that can occur inside the MG.

Protection schemes that can operate in any situation and conditions are then required for both, grid-connected and islanding mode and with any number of DG's, DER's and storage systems during a specific time. In general, any scheme that considers a dynamic behavior without losing protective coordination and reliability. This is possible through more efficient protection devices, such as numerical relays, and more robust communication links, in order to obtain a more accurate response in the equipments present in the MG and implementations economically viable in comparison with the possible losses in a MG without the correct electrical protection. Another possible solution proposed to protect a MG integrated in a distribution network, are those protection schemes that consider the constant changes and variations mentioned above as a feedback, and with this information they adapt to every condition presented in the system.

Adaptive protections

The dynamic behavior is one of the main characteristics or consequences due to the integration of MG's. Then, to operate normally and correctly the MG has to adapt to the variable parameters and the system demands. MG's must have an *administrative system* or *control system* that allows protective devices to act and behave as they should in each branch or section of the distribution system (Sitharthan, Geethanjali, & Karpaga Senthil Pandey, 2016). Hence, these systems will be capable to protect the MG in any of their operational modes (S. Voima et al., 2014).

In this context, a possible solution for the impacts of DG and MG's in electrical distribution networks, considering the attempts to maintain coordination and the protection of the network with conventional schemes, are those protection schemes that modify their settings according with topological and significant changes on the network parameters, the implementation of *adaptive protections* is then suggested.

The concept of the adaptive protection evolved in the 1980's due to the emergence of computer based relays, which allowed to implement several protection functions more easily and to modify their operational characteristics, qualities that were not found in electromechanical and static relays (Alstom

Grid, 2011; CIGRÉ. Commitee 34, 1995; S. Voima et al., 2014). In this way, adaptive protections also makes sense under the concept of smart grids, where the grid tends to integrate the users and generators at any scale, in order to provide a more secure, economical, reliable and efficient electricity (Sampo Voima & Kauhaniemi, 2012). Then, adaptive protections can be defined as "a set of functions that allows the adjustment of their parameters according to modifications or new system requirements, making use of communication protocols" (Gómez-Luna, Candelo, Marlés, Guardiola, & de la Cruz, 2017).

Is necessary to detect the current state of the network according to the total number of connected and disconnected DG's to modify the settings of protective devices. Then some calculations have to be done to select the most accurate settings according with the protection function. Communication links are used among the different relays, generation and storage units in the MG and, as mentioned above, an *administrative system* capable to coordinate all the modifications in an efficient and correct manner in the whole distribution system with the MG. Nonetheless, this is not a task that can be achieved with any protection equipment.

The protection equipments, such as relays, must fulfill some basic characteristics, in order to be implemented in an adaptive scheme and to guarantee their correct operation. In accordance with (Khedezadeh, 2012) and (Hosseini et al., 2016), some of these requirements are:

- Being a digital or numerical relay.
- Several setting groups to be modify locally or remotely.
- Have a programmable logic and allow the interaction with the user.
- Self-testing capabilities, oscillography and sequence-of-events recordings.
- Data transfer through communicative protocols and a communicative infrastructure.

Another characteristic of adaptive protections is the way they interact with all the elements present in the network, a MG in this case; and the process in which coordination and interaction takes place, whether they are coordinated under a specialized management center or if the protection is adapted in an independent way according to the parameters it detects on its zone of operation. This protection schemes are identified as a centralized or decentralized structure and their applications is extended to both, AC and DC MG's. A centralized scheme consists on a central unit or management center that stores and analyzes all the information related to the MG. It establishes communication links and monitoring in every element, and sends control and trip signals one the network conditions have been modified (see Figure 4) (Hosseini et al., 2016; Kawano et al., 2010).

On the other hand, the decentralized scheme consists on agents (software and hardware) distributed along the equipments in the MG. These agents communicate to each

other and interact without a central or global unit, transmitting and analyzing data in a more simple and fast way, as illustrated by Figure 5. Even by dividing the electrical network into zones of operation, agents can establish a more accurate control and protection, this is another application of decentralized schemes that allows to locate and isolate faults in a more effective way (Alwala, Feliachi, & Choudhry, 2012; Brahma & Girgis, 2004; McArthur et al., 2007; Moradi, Razini, & Mahdi Hosseini, 2016).

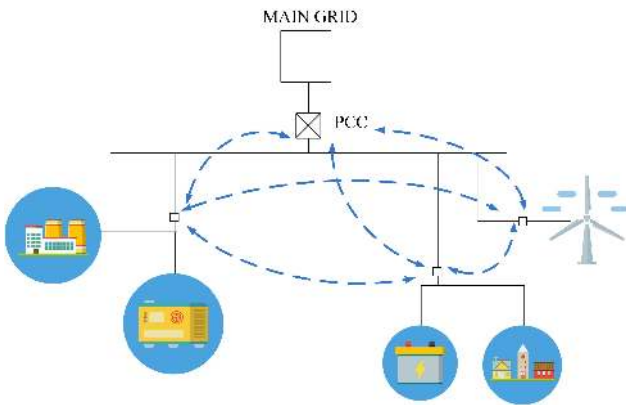

Figure 4. Decentralized adaptive scheme.
Source: Authors

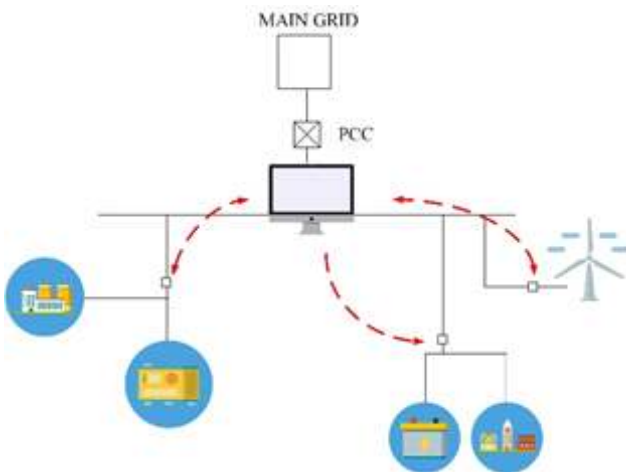

Figure 5. Centralized adaptive scheme.
Source: Authors

Benefits of adaptive protections

As has been mentioned, adaptive protections are an approach to overcome the impacts of the integration of DG's and MG's in electrical distribution networks, and to be able to get more out of the wide advantages they offer to the grid and customers by the integration of substation control and data acquisition with energy management systems. Even

though, when modern electrical networks tend to customers and generators interconnection through technology and communication links.

From both protective schemes described in the last section, is necessary to recognize the benefits and advantages they have to offer. The centralized scheme provides a complete and constant monitoring of the MG. Hence, with any change in their characteristics, the central unit will receive signals from any equipment and device and then, evaluate the networks conditions according to the operational state of every unit and if necessary, update their protective settings or control parameters. The central unit will store the new characteristics of the MG in the case that this configuration is presented again in the future. Worth noting that this scheme ensures a adequate protection coordination because no element acts or modify it parameters arbitrarily until they have been validated by the central unit or management center (Azari, Ojaghi, & Mazlumi, 2015; Hosseini et al., 2016).

In general, the decentralized scheme offers the possibility of addressing major problems by dividing it among the different agents present in the MG, where each of those have a specific function and responsibility. Their evaluation process and analysis is limited by the interaction with nearer agents, present in their zones of influence. The protection coordination and control is done only by the information that the others agents can provide. A great advantage of this scheme is the flexibility and modularity of their application, since they allow and easy incorporation and extraction of agents as the MG is extended or modified (Moradi et al., 2016). One of the agents application is the implementation of a protection coordination platform known as MAS-ProteC in another platform to simulate future power systems and manage smartgrid markets (Oliveira, Pinto, Morais, & Vale, 2012).

Conclusions

The use of alternative and renewable energy resources might be very advantageous, mainly by the fact of reducing the use of fossil fuel-based energies. However, the inclusion of energy sources or distributed generation units into the electrical system, forming distribution subsystems as microgrids, must be study and analyze carefully. The impacts over the power system must be reduced, in order to obtain the maximum advantage of these resources and to guarantee the quality of electrical service, and security for the wells and customers utilities.

Impacts of distributed generation in microgrids can be very significant since the electrical protection point of view. This is why this paper aimed to contextualize the impacts and challenges of integration of distributed generation over the protective devices, presenting one of the alternatives proposed by several researchers as adaptive protections.

Acknowledgements

The authors would like to thank to Potencia y Tecnologías Incorporadas, PTI S.A for the support during this process, the GITICAP research group from the same company, for the contributions during the development of this paper. Similarly, to thank the Universidad del Valle for the participation and support in the research project.

References

- Almeida, E. Leite, H. Silva, N. (2014). Real-time Closed-Loop Test to Adaptive Protection in a Smart-Grid Context. *13th International Conference on Development in Power System Protection 2016 (DPSP)*, (July), 1-5. DOI: 10.1049/cp.2016.0061
- Alstom Grid. (2011). *Network Protection & Automation Guide. Protective Relays, Measurement & Control*.
- Alwala, S., Feliachi, A., & Choudhry, M. A. (2012). Multi Agent System based fault location and isolation in a smart microgrid system. *Innovative Smart Grid Technologies (ISGT), 2012 IEEE PES*, 1-4. DOI: 10.1109/isgt.2012.6175813
- Arango, A., Carvajal, S., & Arango, S. (2011). Contribution of Distributed Generation to Voltage Control. *Ingeniería e Investigación*, 31(2), 153-158.
- Armas teyra, M. A., & Alvin, R. P. (2013). Oscilaciones de Potencia, Tensión y Corriente en Unidades de Generación Distribuida. *Ingeniería Energética*, XXXIV(2), 108-118. Retrieved from: <http://scielo.sld.cu/pdf/rie/v34n2/rie03213.pdf>
- Azari, M., Ojaghi, M., & Mazlumi, K. (2015). An enhanced adaptive algorithm to mitigate mis-coordination problem of the third zone of distance relays. *Journal of Applied Research and Technology*, 13(1), 87-96. DOI: 10.1016/S1665-6423(15)30007-9
- Barker, P. P., & De Mello, R. W. (2000). Determining the impact of distributed generation on power systems. I. Radial distribution systems. *Power Engineering Society Summer Meeting, 2000. IEEE*, 3(c), 1645-1656 vol. 3. DOI: 10.1109/PSS.2000.868775
- Bhattacharai, B. P., Bak-Jensen, B., Chaudhary, S., & Pillai, J. R. (2015). An adaptive overcurrent protection in smart distribution grid. In *2015 IEEE Eindhoven PowerTech, PowerTech 2015* (pp. 1-6). IEEE. DOI: 10.1109/PTC.2015. 7232310
- Bhise, D. R., Kankale, R. S., & Jadhao, S. (2017). Impact of distributed generation on protection of power system. *2017 International Conference on Innovative Mechanisms for Industry Applications (ICIMIA)*, (Icimia), 399-405. DOI: 10.1109/ICIMIA.2017.7975644
- Bonilla-Gómez, N. (2017). Propuesta de diseño de una microred en la comunidad de Santa Elena, Pérez Zeledón, basada en Whites Lane Smart Micro Grid. *Revista Tecnología En Marcha*, 30(5), 55. DOI: 10.18845/tm.v30i5.3224
- BP. (2018). *BP Statistical Review of World Energy 2018*. 67th Edition.
- Brahma, S. M., & Girgis, A. A. (2004). Development of Adaptive Protection Scheme for Distribution Systems with High Penetration of Distributed Generation. *IEEE Transactions on Power Delivery*, 19(1), 56-63. DOI: 10.1109/TPWRD.2003.820204
- Che, L., Khodayar, M. E., & Shahidehpour, M. (2014). Adaptive protection system for microgrids: Protection practices of a functional microgrid system. *IEEE Electrification Magazine*, 2(1), 66-80. DOI: 10.1109/MELE.2013.2297031
- CIGRÉ. Committee 34. (1995). *Adaptive Protections and Control. Final Report*. Paris. Coffele, F., Booth, C., & Dyśko, A. (2014). An Adaptive Overcurrent Protection Scheme for Distribution Networks. *IEEE Transactions on Power Delivery*, 30(2), 561-568. DOI: 10.1109/TPWRD. 2013.2294879
- Comisión de Regulación de Energía y Gas. CREG. (2018). Resolución 030 de 2018. Colombia.
- Correa-Henao, G. J., & Rojas-Zerpa, J. C. (2017). Marco de referencia para la planificación de generación distribuida en zonas no interconectadas. *Iteckne*, 14(1), 70-87. DOI: 10.15332/iteckne.v14i1.1632
- de las Casas, Ma. B., & Boza, Y. Y. (2009). Retos a las Protecciones Eléctricas en las Redes de Distribución con Generación Distribuida. *Revista Chilena de Ingeniería*, 17(1), 101-107.
- Do Nascimento, L. L., & Rolim, J. G. (2013). Multi-Agent system for adaptive protection in microgrids. In *2013 IEEE PES Conference on Innovative Smart Grid Technologies, ISGT LA 2013* (pp. 1-8). IEEE. DOI: 10.1109/ISGT-LA.2013.6554435
- Ehrenberger, J. (2015). Use of directional overcurrent protection scheme for distributed generation systems. In *2015 16th International Scientific Conference on Electric Power Engineering (EPE)* (pp. 325-330). IEEE. DOI: 10.1109/EPE.2015.7161082
- Garzón-Hidalgo, J. D., & Saavedra-Montes, A. J. (2015). Una metodología de diseño de micro redes para zonas no interconectadas de Colombia. *Tecnológicas*, 20(39), 15. DOI: 10.22430/22565337.687
- Gers, J. M., & Viggiano, C. (2016). Protective relay setting criteria considering DERs and distributed automation. Retrieved from: <http://ieeexplore.ieee.org.bd.univalle.edu.co/document/7795059/>
- Gómez-Luna, E., Candelo, J. E., Marlés, E., Guardiola, J. M., & de la Cruz, J. (2017). Impact of adaptive protections in electric microgrids, challenges and future trends. White paper.
- Gönen, T. (2014). *Electric Power Distribution Engineering* (3rd ed.). CRC Press.
- Granja, A., de Souza, T., Sobrinho, P., & Santos, D. (2018). Study of Power Quality at the Point of Common Coupling of a Low Voltage Grid and a Distributed Generation System of 7.8 kWp in a Tropical Region. *Energies*, 11(6), 1539. DOI: 10.3390/en11061539
- Grisales Noreña, L. F., Restrepo Cuestas, B. J., & Jaramillo Ramirez, F. E. (2017). Ubicación y dimensionamiento de generación distribuida: Una revisión. *Ciencia e Ingeniería Neogranadina*, 27(2), 157-176. DOI: 10.18359/rcin.2344

- Guacaneme, J. A., Velasco, D., & Trujillo, C. L. (2014). Revisión de las características de sistemas de almacenamiento de energía para aplicaciones en micro redes. *Información Tecnológica*, 25(2), 175-188. DOI: 10.4067/S0718-07642014000200020
- Gupta, A., Varshney, A., Swathika, O. V. G., & Hemamalini, S. (2016). Dual Simplex Algorithm Aided Adaptive Protection of Microgrid. In *Proceedings - 2015 International Conference on Computational Intelligence and Communication Networks, CICN 2015* (pp. 1505-1509). IEEE. DOI: 10.1109/CICN.2015.338
- Hooshyar, A., & Irvani, R. (2017). Microgrid Protection. *Proceedings of the IEEE*, 105(7), 1332-1353. DOI: 10.1109/JPROC.2017.2669342
- Horowitz, S. H., & Phadke, A. G. (2014). *Power System Relaying* (4th ed.). Wiley.
- Hosseini, S. A., Abyaneh, H. A., Sadeghi, S. H. H., Razavi, F., & Nasiri, A. (2016, October 1). An overview of microgrid protection methods and the factors involved. *Renewable and Sustainable Energy Reviews*. Pergamon. DOI: 10.1016/j.rser.2016.05.089
- IEEE. (2014). *519-2014 IEEE Recommended Practice and Requirements for Harmonic Control in Electric Power Systems*. Retrieved from: <http://ieeexplore.ieee.org.bd.univalle.educo/document/6826459/>
- Ishchenko, D., Oudalov, A., & Stoupis, J. (2012). Protection coordination in active distribution grids with IEC 61850. In *Proceedings of the IEEE Power Engineering Society Transmission and Distribution Conference* (pp. 1-6). IEEE. DOI: 10.1109/TDC.2012.6281478
- Kawano, F., Baber, G. P., Beaumont, P. G., Fukushima, K., Miyoshi, T., Shono, T., Umeda, S. (2010). Intelligent protection relay system for smart grid. In *10th IET International Conference on Developments in Power System Protection (DPSP 2010). Managing the Change* (pp. 13-13). IET. DOI: 10.1049/cp.2010.0211
- Khaledian, A., Vahidi, B., & Abedi, M. (2014). Harmonic distorted load control in a microgrid. *Journal of Applied Research and Technology*, 12(4), 792-802. DOI: 10.1016/S1665-6423(14)70095-1
- Khederzadeh, M. (2012). Adaptive setting of protective relays in microgrids in grid-connected and autonomous operation. *11th IET International Conference on Developments in Power Systems Protection (DPSP), Birmingham*, P14-P14. DOI: 10.1049/cp.2012.0076
- Kroposki, B., Lasseter, R., Ise, T., Morozumi, S., Papathanassiou, S., & Hatziaargyriou, N. (2008). Making microgrids work. *IEEE Power and Energy Magazine*, 6(3), 40-53. DOI: 10.1109/MPE.2008.918718
- Laaksonen, Hannu; Ishchenko, Dmitry; Oudalov, A. (2014). Adaptive protection and microgrid control design for Hailuoto Island. *IEEE Transactions on Smart Grid*, 5(3), 1486-1493. DOI: 10.1109/TSG.2013.2287672
- Lepadat, I., Helerea, E., Abagiu, S., & Mihai, C. (2017). Impact of Distributed Generation on voltage profile and power losses in a test power grid. In *2017 International Conference on Optimization of Electrical and Electronic Equipment (OPTIM) & 2017 Intl Aegean Conference on Electrical Machines and Power Electronics (ACEMP)* (pp. 128-133). IEEE. DOI: 10.1109/OPTIM.2017.7974959
- Li, F., Li, R., & Zhou, F. (2015). *Microgrid Technology and Engineering Application*. Elsevier.
- López-Lezama, J. M., Buitrago, L. F., & Villada, F. (2015). Ubicación, Dimensionamiento y Precio de Contrato Óptimo de Generación Distribuida en Sistemas de Distribución. *Informacion Tecnologica*, 26(6), 109-120. DOI: 10.4067/S0718-07642015000600013
- Luna, L., & Parra, E. (2011). Methodology for assessing the impacts of distributed generation interconnection. *Ingeniería e Investigación*, 31(2), 36-44.
- Mahat, P., Chen, Z., Bak-Jensen, B., & Bak, C. L. (2011). A simple adaptive overcurrent protection of distribution systems with distributed generation. *IEEE Transactions on Smart Grid*, 2(3), 428-437. DOI: 10.1109/TSG.2011.2149550
- McArthur, S. D. J., Davidson, E. M., Catterson, V. M., Dimeas, A. L., Hatziaargyriou, N. D., Ponci, F., & Funabashi, T. (2007). Multi-Agent Systems for Power Engineering Applications — Part I: Concepts, Approaches, and Technical Challenges. *IEEE Transactions on Power Systems*, 22(4), 1743-1752. DOI: 10.1109/TPWRS.2007.908471
- Meneses, C. P. (2011). Algorithm for Probabilistic Analysis of Distribution Systems With Distributed Generation. *Dyna*, 79-87. Retrieved from: <http://scholar.google.com/scholar?hl=en&btnG=Search&q=intitle:ALGORITHM+FOR+PROBABILISTIC+ANALYSIS+OF+DISTRIBUTION+SYSTEMS+WITH+DISTRIBUTED+GENERATION#0>
- Mina, J. D. (2017). Una propuesta de integración de arquitecturas de generación descentralizada en ambientes de micro-redes. *Entre Ciencia e Ingeniería*, 1(22), 1-3.
- Monadi, M., Gavriluta, C., Luna, A., Candela, J. I., & Rodriguez, P. (2017). Centralized protection strategy for medium voltage DC microgrids. *IEEE Transactions on Power Delivery*, 32(1), 430-440. DOI: 10.1109/TPWRD.2016.2600278
- Moradi, M. H., Razini, S., & Mahdi Hosseini, S. (2016). State of art of multiagent systems in power engineering: A review. *Renewable and Sustainable Energy Reviews*, 58, 814-824. DOI: 10.1016/j.rser.2015.12.339
- Mozina, C. (2010). Impact of green power distributed generation. *IEEE Industry Applications Magazine*, 16(4), 55-62. DOI: 10.1109/MIAS.2010.936970
- Muda, H., & Jena, P. (2017a). Real time simulation of new adaptive overcurrent technique for microgrid protection. In *2016 National Power Systems Conference, NPSC 2016* (pp. 1-6). IEEE. DOI: 10.1109/NPSC.2016.7858897
- Muda, H., & Jena, P. (2017b). Superimposed Adaptive Sequence Current Based Microgrid Protection: A New Technique. *IEEE Transactions on Power Delivery*, 8977(c), 1-1. DOI: 10.1109/TPWRD.2016.2601921

- Narváez, P. A., López-Lezama, J. M., & Velilla, E. (2015). Ubicación de generación distribuida para minimización de pérdidas usando un algoritmo genético híbrido. *Información Tecnológica*, 26(3), 123-131. DOI: 10.4067/S0718-07642015000300016
- Nascimento, J. P., Brito, N. S. D., & De Souza, B. A. (2016). An adaptive protection algorithm for distribution systems with distributed generation. In *2015 IEEE PES Innovative Smart Grid Technologies Latin America, ISGT LATAM 2015* (pp. 165-170). IEEE. DOI: 10.1109/ISGT-LA.2015.7381147
- Oliveira, P., Pinto, T., Morais, H., & Vale, Z. (2012). MASGrIP a multi-agent smart grid simulation platform. In *IEEE Power and Energy Society General Meeting* (pp. 1-8). IEEE. DOI: 10.1109/PESGM.2012.6345649
- Palma-Behnke, R., Ortiz, D., Reyes, L., Jiménez-Estévez, G., & Garrido, N. (2011). A social SCADA approach for a renewable based microgrid - The Huatacondo project. In *IEEE Power and Energy Society General Meeting*. DOI: 10.1109/PES.2011.6039749
- Piescorovsky, E. C., & Schulz, N. N. (2017). Comparison of Programmable Logic and Setting Group Methods for adaptive overcurrent protection in microgrids. *Electric Power Systems Research*, 151, 273-282. DOI: 10.1016/j.epsr.2017.05.035
- Ramos, M. J. S., Bernardon, D. P., & Comassetto, L. (2013). Analysis of coordination and selectivity of protection systems during reconfigurations of distribution energy systems in real time. In *2013 IEEE PES Conference on Innovative Smart Grid Technologies, ISGT LA 2013* (pp. 1-6). IEEE. DOI: 10.1109/ISGT-LA.2013.6554461
- Renewable Energy Policy Network for the 21st Century (REN21). (2018). *Renewables 2018 Global Status Report*. REN21.
- Schweickardt, G., Manuel, J., & Alvarez, G. (2013). On-Line Dynamic Security Assessment of a Micro-Grid Using Fuzzy Logic and Distributed Processing. *Dyna*, 31-40.
- Shih, M. Y., & Enriquez, A. C. (2014). Alternative coordination approaches for implementation in Smart Grid. In *2014 North American Power Symposium, NAPS 2014* (pp. 1-7). IEEE. DOI: 10.1109/NAPS.2014.6965368
- Shuai, Z., Sun, Y., Shen, Z. J., Tian, W., Tu, C., Li, Y., & Yin, X. (2016). Microgrid stability: Classification and a review. *Renewable and Sustainable Energy Reviews*, 58, 167-179. DOI: 10.1016/j.rser.2015.12.201
- Singh, M. (2013). Protection coordination in grid connected & islanded modes of micro-grid operations. In *2013 IEEE Innovative Smart Grid Technologies - Asia, ISGT Asia 2013* (pp. 1-6). IEEE. DOI: 10.1109/ISGT-Asia.2013.6698772
- Sitharthan, R., Geethanjali, M., & Karpaga Senthil Pandey, T. (2016). Adaptive protection scheme for smart microgrid with electronically coupled distributed generations. *Alexandria Engineering Journal*, 55(3), 2539-2550. DOI: 10.1016/j.aej.2016.06.025
- Su, C., Liu, Z., Chen, Z., & Hu, Y. (2014). An adaptive control strategy of converter based DG to maintain protection coordination in distribution system. In *IEEE PES Innovative Smart Grid Technologies Conference Europe (Vol. 2014-Janua, pp. 1-6)*. IEEE. DOI: 10.1109/ISGTEurope.2014.7028900
- Teimourzadeh, S., Aminifar, F., & Davarpanah, M. (2017). Microgrid dynamic security: Challenges, solutions and key considerations. *The Electricity Journal*, 30(4), 43-51. DOI: 10.1016/j.tej.2017.04.015
- Tello-maita, J., & Marulanda-guerra, A. (2017). Optimization models for power systems in the evolution to smart grids?: A review. *Dyna*, 84(202), 102-111. Retrieved from: <http://www.redalyc.org/articulo.optimizationmodelsforpower>
- Torres, E., Marlés, E., & Caicedo, G. (2018). *DESARROLLO DE UNA HERRAMIENTA COMPUTACIONAL PARA ESPECIFICAR TRANSFORMADORES DE PUESTA A TIERRA PARA GENERADORES DE GRAN POTENCIA*. Universidad del Valle.
- Tummasit, N., Premrudeepreechacharn, S., & Tantichayakorn, N. (2016). Adaptive overcurrent protection considering critical clearing time for a microgrid system. In *Proceedings of the 2015 IEEE Innovative Smart Grid Technologies - Asia, ISGT ASIA 2015* (pp. 1-6). IEEE. DOI: 10.1109/ISGT-Asia.2015.7387061
- Urbina, C. (2015). *ANÁLISIS DEL IMPACTO SOBRE LAS PROTECCIONES ELÉCTRICAS AL INSTALAR SISTEMAS SOLARES FOTOVOLTAICOS EN UNA RED DE DISTRIBUCIÓN CON NIVEL DE TENSIÓN 13.2 kV*. Universidad Nacional de Colombia.
- Ustun, T. S., Ozansoy, C., & Zayegh, A. (2012). Modeling of a centralized microgrid protection system and distributed energy resources according to IEC 61850-7-420. *IEEE Transactions on Power Systems*, 27(3), 1560-1567. DOI: 10.1109/TPWRS.2012.2185072
- Voima, S., & Kauhaniemi, K. (2012). Adaptivity of Protection in Smart Grids. *PAC World Conference*, (June), 25-28. Retrieved from: <http://sgemfinalreport.fi/files/P024.pdf>
- Voima, S., Laaksonen, H., & Kauhaniemi, K. (2014). Adaptive protection scheme for smart grids. *Developments in Power System Protection (DPSP 2014), 12th IET International Conference On*, 1-6. DOI: 10.1049/cp.2014.0139
- Yang, J., & Wang, Y. (2015). Review on protection issues of low-voltage distribution network with multiple power-electronic-converter-interfaced distribution energy resources. *International Conference on Renewable Power Generation (RPG 2015)*, 1-6. DOI: 10.1049/cp.2015.0327