

The WSR-88D and the WSR-88D Operational Support Facility

Timothy D. Crum*
and Ron L. Alberty
WSR-88D Operational
Support Facility,
Norman, Oklahoma

Abstract

The Weather Surveillance Radar—1988 Doppler (WSR-88D) System is the product of the Next Generation Weather Radar (NEXRAD) program, a joint effort of the U.S. Departments of Commerce, Defense, and Transportation. WSR-88D Systems meet the common needs of the three agencies and are being installed across the United States and at selected overseas sites. These systems provide Doppler capabilities, increased receiver sensitivity, and real-time display of base and derived products that will enable forecasters to improve the detection of and give greater advanced warning of severe weather events. Many nonsevere weather and hydrological applications are also expected.

WSR-88D Systems will be modified and enhanced during their operational life to meet changing requirements, technological advancements, and improved understanding of the application of these systems to real-time operations. The NEXRAD agencies established the Operational Support Facility (OSF) to provide centralized WSR-88D operator training and software, maintenance, and engineering support.

This paper provides an overview of the NEXRAD program, the WSR-88D System, and the role of the OSF in supporting the WSR-88D and its users. Examples of some of the products are also presented.

1. Introduction

a. *The NEXRAD program*

The Next Generation Weather Radar (NEXRAD) program is a joint effort of the U.S. Departments of Commerce (DOC), Defense (DOD), and Transportation (DOT) to develop, procure, deploy, and support the advanced Weather Surveillance Radar—1988 Doppler (WSR-88D) System that meets the common operational needs of the three agencies. The WSR-88D System will replace non-Doppler meteorological radars currently employed by the National Weather Service (NWS), U.S. Air Force, Naval Oceanography Command, and Federal Aviation Administration (FAA). The NEXRAD Joint System Program Office (JSPO), located in the National Oceanic and Atmospheric Administration (NOAA) System Program Office, manages the NEXRAD program for the three agencies.

The NEXRAD program's major milestones are depicted in Fig. 1. The Joint Doppler Operational Project (JDOP) was established in 1976 at the National Severe Storms Laboratory (NSSL) in Norman, Oklahoma, to investigate the real-time use of a meteorological Doppler radar to identify severe or tornadic thunderstorms (JDOP 1979). Subsequent tests during the next three years involving National Weather Service and U.S. Air Force Air Weather Service forecasters demonstrated that Doppler radar offered marked improvement for early and accurate identification of thunderstorm hazards, tornadoes, and squall lines. In concert with the JDOP activity, an interagency NEXRAD working group was organized under the Office of the Federal Coordinator for Meteorological Services and Supporting Research. This working group, which was the focus for interagency weather radar development and planning activities, produced a 1979 NEXRAD concept paper. The concept paper outlined an approach for the development, procurement, and operation of a joint (DOC, DOD, and DOT) national weather radar network. This paper recommended prompt action to establish a joint program management activity, define agency responsibilities, establish detailed program plans, and initiate requirements definition and specification preparation (NEXRAD 1980). The NEXRAD JSPO was established in 1979 to carry out the development, acquisition, and installation activities.

During JDOP, researchers developed meteorological analysis modules to support real-time meteorological needs. After the JSPO was formed, the NEXRAD Interim Operational Test Facility (IOTF), a branch of the JSPO located at the NSSL, developed NEXRAD-type displays to demonstrate and evaluate the real-time meteorological analysis modules. The IOTF assessed whether these modules were operationally acceptable in a variety of meteorological conditions (NEXRAD 1984). Another assessment of the operational utility of NEXRAD was performed in the Boston, Massachusetts, area in 1983/84 (Forsyth et al. 1985).

The U.S. Air Force Operational Test and Evaluation Center (AFOTEC) conducted two operational tests and evaluations for the NEXRAD program between 1986 and 1989. AFOTEC participants evaluated the

*U.S. Air Force, Headquarters Air Weather Service, Operating Location K, Norman, Oklahoma
©1993 American Meteorological Society

NEXRAD Milestones

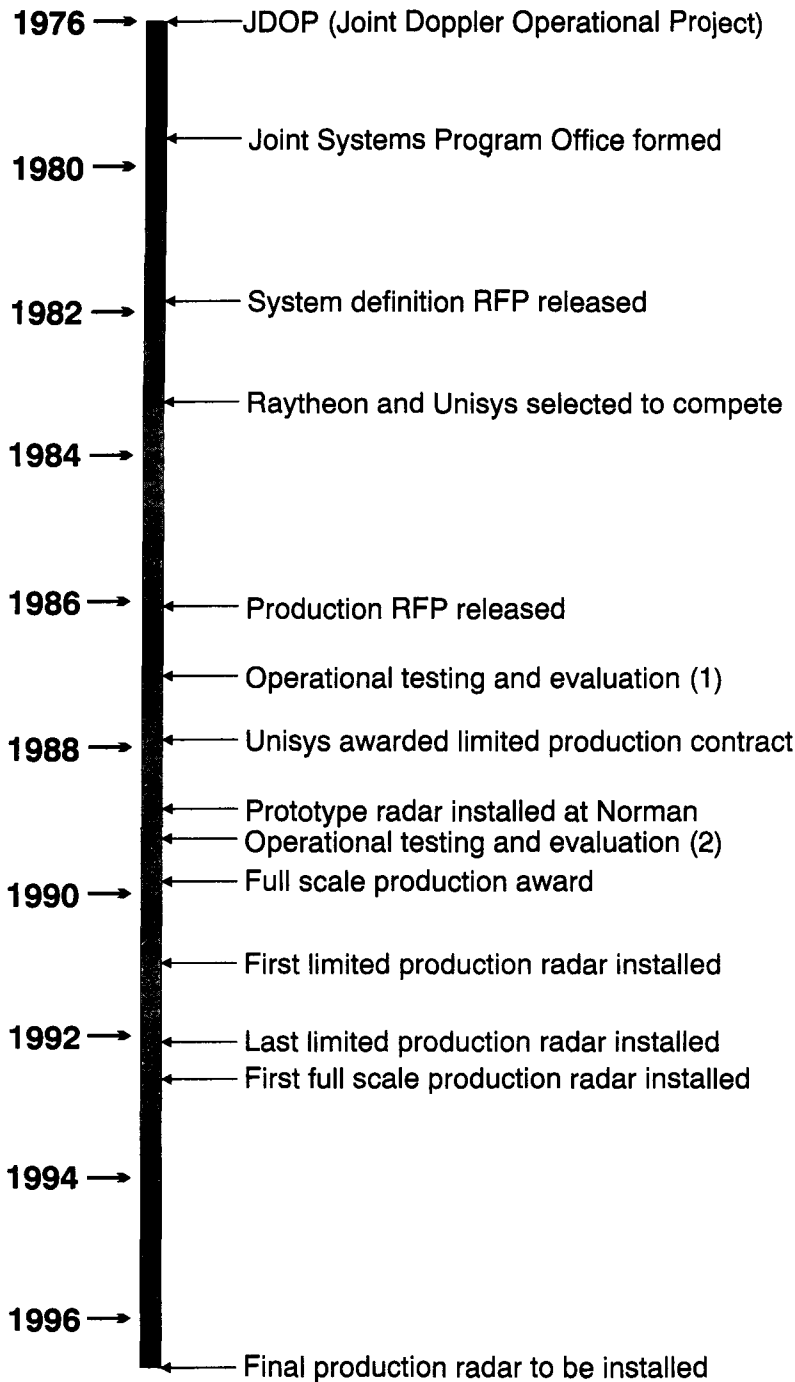

FIG. 1. NEXRAD program major milestones.

operational effectiveness and suitability of *pre-production* radars developed by the competing contractors. The results of these evaluations led to the selection of the Unisys Corporation as the NEXRAD

contractor and formed the basis for the full-scale production decision in January 1990. installed in early 1992. Installation of the full-scale production systems began during the summer of 1992. The installation and acceptance rate for the radars, initially one per month, is scheduled to accelerate to

contractor and formed the basis for the full-scale production decision in January 1990.

b. The WSR-88D System

The WSR-88D System incorporates many recent innovations in remote sensing, electronic data processing and display, and application of microscale and mesoscale meteorological knowledge. These capabilities combine to provide greatly improved guidance to the triagency users to assist their weather forecasting and warning decision-making process. WSR-88D Systems are expected to be of immense value to the nation for additional purposes, many of which are yet to be discovered.

When the first WSR-88D System was installed near Oklahoma City, Oklahoma, in the fall of 1990, a major era of modernization and associated restructuring of the United States National Weather Service began. When the last installation is completed in 1996, approximately 140 operational WSR-88D Systems (NWS and U.S. Air Force) and five systems to support supply depot and training activities will be installed in the continental United States (Fig. 2). Up to 13 WSR-88D Systems will be installed at FAA sites in Alaska, Hawaii, the Caribbean, and selected DOD bases overseas. *The Federal Meteorological Handbook No. 11, Part A, (FMH No. 11 1991a)* lists locations for these radars.

The WSR-88D network will provide nearly complete radar coverage within the contiguous United States. The network coverage at 10 000 ft above site level is nearly continuous except for areas in the western United States caused predominantly by mountainous terrain that blocks the lower-level scans. Leone et al. (1989) describe the siting criteria for the WSR-88D Systems.

The last of 10 limited production phase WSR-88D Systems was in-



FIG. 2. Location of WSR-88D Radar Data Acquisition (RDA) units in the contiguous United States when installation is completed in 1996. A site will be added in the Fort Polk, Louisiana, area.

four per month by late 1993. Each older radar will be decommissioned after the WSR-88D for its area is commissioned.

c. The WSR-88D Operational Support Facility

Under the auspices of the NEXRAD program, the WSR-88D Operational Support Facility (OSF) was established in Norman, Oklahoma, in 1988. The OSF will provide centralized radar meteorological computer software, maintenance, and engineering support for all WSR-88D Systems after their installation and acceptance. The OSF Operations Training Branch provides operator training for all NWS forecasters and a cadre of DOD operators. In addition, the OSF operates and maintains two WSR-88D Systems to assist in the OSF's life-cycle support and improvement responsibilities.

The triagency nature of the NEXRAD program will continue during the WSR-88D System's operational life. Each operating agency will maintain and operate the WSR-88D equipment under its control. The National Logistics Supply Center and National Reconditioning Center (both located in Kansas City, Missouri) provide centralized provisioning and repair support. The NWS Training Center in Kansas City, Missouri, trains NWS electronics technicians to maintain the

WSR-88D System while the DOD Training Center at Keesler AFB, Mississippi, trains DOD and DOT maintenance personnel.

2. WSR-88D System overview

WSR-88D Systems collect, process, and display high-resolution and high-accuracy reflectivity, mean radial velocity, and spectrum width (a measure of the variability of radial velocities in the sample volume) data. From these basic Doppler quantities, computer-processed algorithms generate a suite of meteorological and hydrological analysis products. When combined with the user's meteorological knowledge of storm structure and internal processes, these products provide crucial guidance for decisions that must be made by forecasters or meteorological observers. Products of these algorithms will be vital ingredients for providing short-term forecasts that are more accurate than now possible, for detecting and providing more precise warnings of threatening wind conditions, and for evaluating the potential threat of devastating floods and other phenomena.

Figure 3 depicts the three major functional compo-

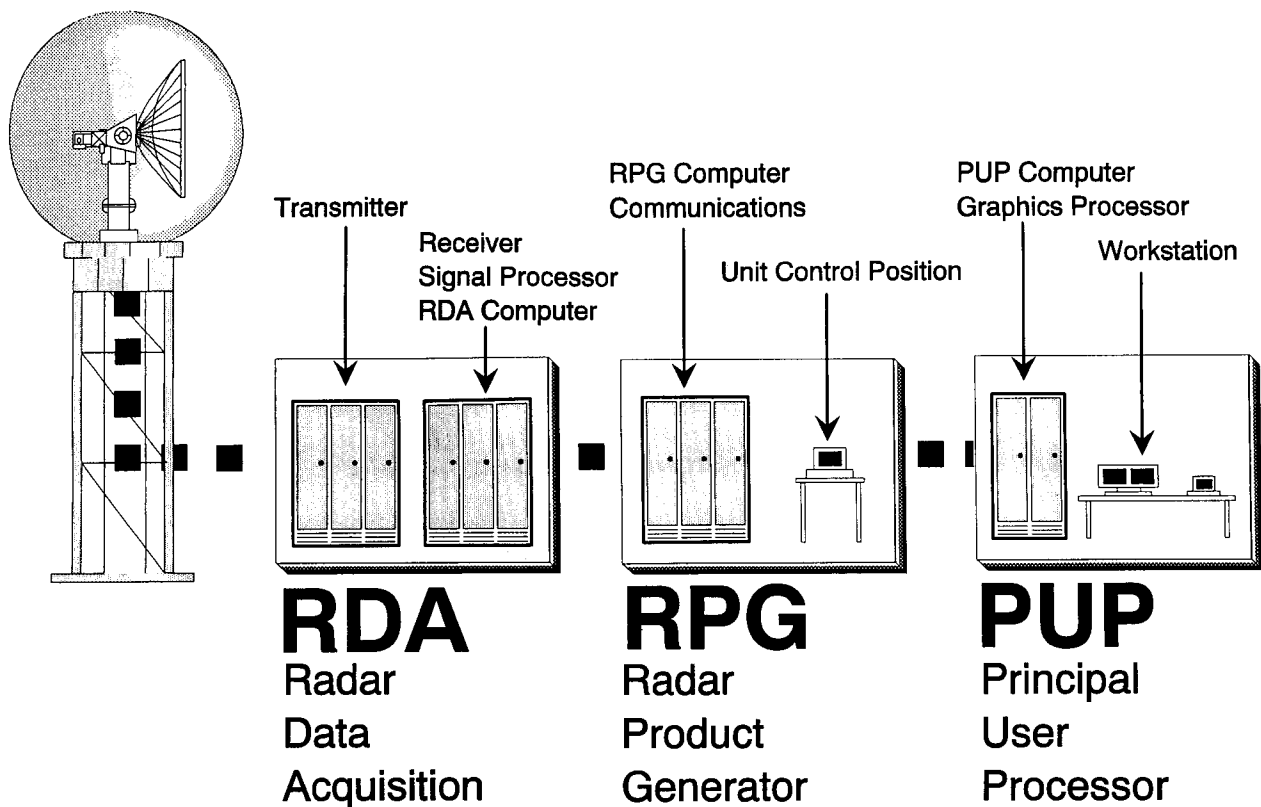

FIG. 3. The three major components of the WSR-88D System. The major subcomponents of each of the main components are also depicted. A wideband ($1.544 \text{ Mbits s}^{-1}$) communications link transmits RDA data to the Radar Product Generator (RPG). RPGs are connected to Principal User Processors (PUPs) by a narrowband (9.6 kbits s^{-1}) link (56 kbits s^{-1} for NWS collocated PUPs).

nents of a WSR-88D System: Radar Data Acquisition (RDA), Radar Product Generator (RPG), and Principal User Processor (PUP) along with the communications lines that link them. Particularly noteworthy in the system is the dominant influence of computers within each major functional component. The extraordinary amount of data that must be rapidly processed, as the radar continuously scans its environment, demands their use. The computers execute meteorological algorithms that process this stream of data. Figure 4 depicts the flow of base data from the RDA, through the algorithms executed in the RPG, to display on a PUP workstation as meteorological or hydrological products. In this paper and companion papers (Alberty et al. 1991; Klazura et al. 1992), we present a brief system synopsis of how WSR-88D Systems create products. Additional detail may be found in FMH No. 11, Part B (1990), Part C (1991b), and Part D (1992) and Heiss et al. (1990).

a. The Radar Data Acquisition unit

Radar Data Acquisition (RDA) units acquire and process Doppler weather radar data. An RDA unit

consists of the antenna, pedestal, radome, tower, klystron transmitter, receiver, minicomputer, and signal processor. The S-band ($10.0\text{--}11.1\text{-cm}$ wavelength, $2700\text{--}3000 \text{ MHz}$) klystron transmitter normally transmits with a nominal peak power output of 750 kW and a pulse width of $1.57 \mu\text{s}$ for pulse repetition frequencies between 318 and 1304 Hz or a pulse width of $4.7 \mu\text{s}$ for pulse repetition frequencies between 318 and 452 Hz . The parabolic antenna has a diameter of 8.5 m (28 ft), an antenna mainlobe one-way 3-dB beamwidth of approximately 0.95° , and a first sidelobe 27 dB below the main lobe. The transmitted signal has linear horizontal polarization.

The status and control processor in the RDA controls antenna scanning patterns, signal processing, ground clutter suppression, status monitoring, error detection, automatic calibration, and the capability to record the base data. The system provides mean radial velocity data and spectrum width data at spatial resolution of 0.25 km and a velocity resolution of 0.5 m s^{-1} . Reflectivity data have spatial resolution of 1 km and data resolution of 0.5 dB_e . These base data are output in digital form by the signal processor and

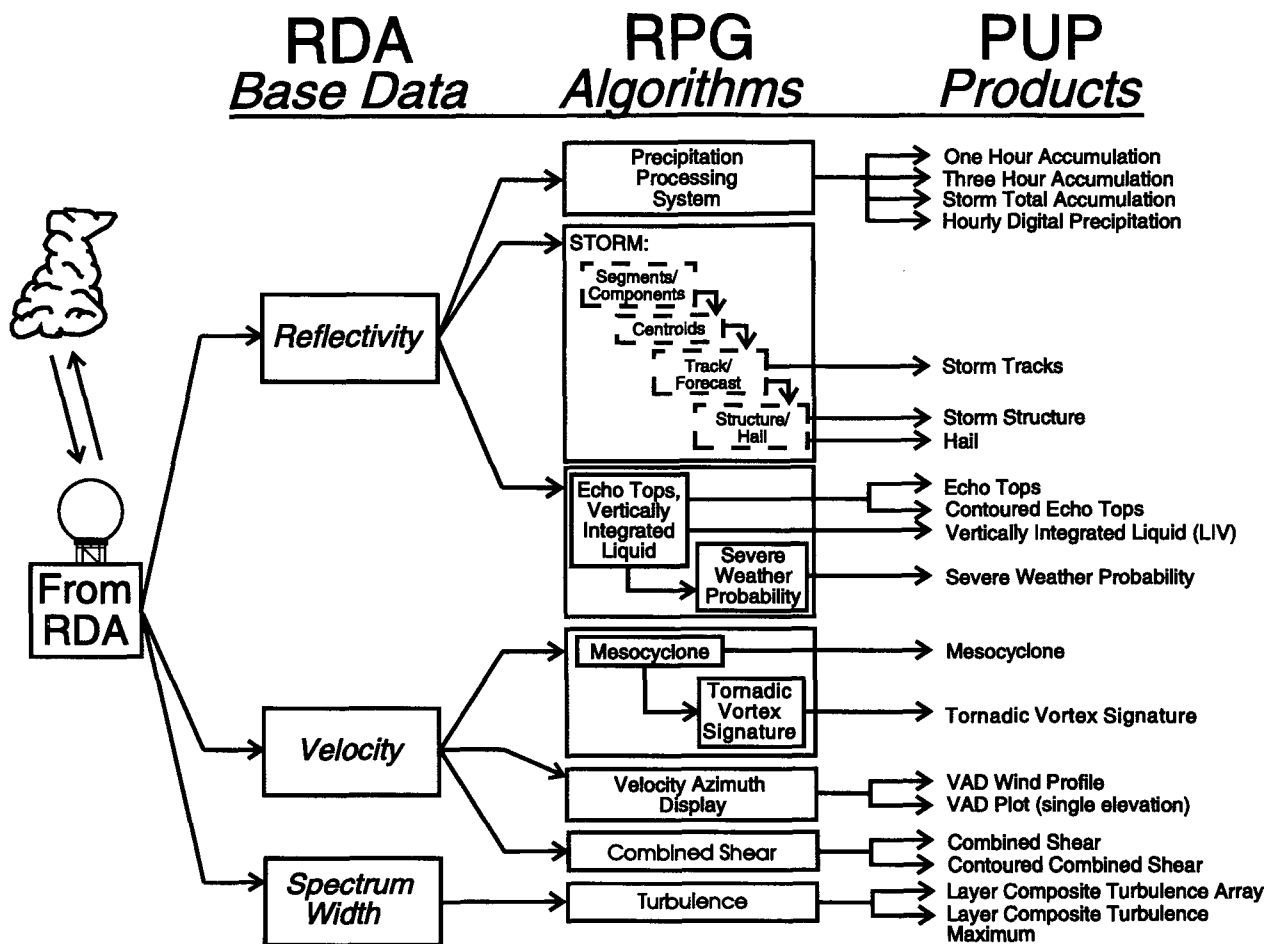

FIG. 4. The flow of WSR-88D base data from the RDA to display as a product for the operator at the PUP. The six "families" of meteorological algorithms executed in the RPG are shown.

include system status information to properly interpret the data. These data can be recorded as Level II data (Crum et al. 1993).

b. Radar Data Acquisition—Radar Product Generator connection

There are two RDA—RPG configurations: 1) collocated with the RPG at the RDA site, and 2) separate with the RPG at the forecast office and the RDA at another location, possibly many miles from the forecast office. The RDA and RPG are connected with a full duplex wideband ($1.544 \text{ Mbits s}^{-1}$) communications link. For collocated sites, the RDA and RPG are directly connected. For separated sites, a commercial T1 link or microwave line-of-sight system is used for the wideband link.

c. The Radar Product Generator

The Radar Product Generator (RPG), where most of the data processing is done, executes algorithms to convert RDA-generated base data into meteorologi-

cal and hydrological products. The RPG also provides on-line base data [two volume scans (as defined in section 3b)] and product storage (up to 6 h), velocity dealiasing, control and status monitoring of the RDA and RPG, product recording (Level III data on NWS RPGs), and product distribution. The operator controls the RPG and RDA from the RPG's application terminal—the unit control position (UCP).

d. Radar Product Generator—Principal User Processor connection

Figure 5 shows the numerous connections a WSR-88D RPG can have. As many as 31 users (expandable to 47) can be simultaneously connected to an RPG. RPGs are connected to PUPs by either dedicated or dial-in connections on 9.6 kbits s^{-1} narrowband links. At NWS sites, PUPs collocated with RPGs are connected to that RPG by a 56 kbits s^{-1} line. In the modernized NWS the 56 kbits s^{-1} connection will be to an Automated Weather Interactive Processing System (AWIPS) where that

WSR-88D Multiple Users

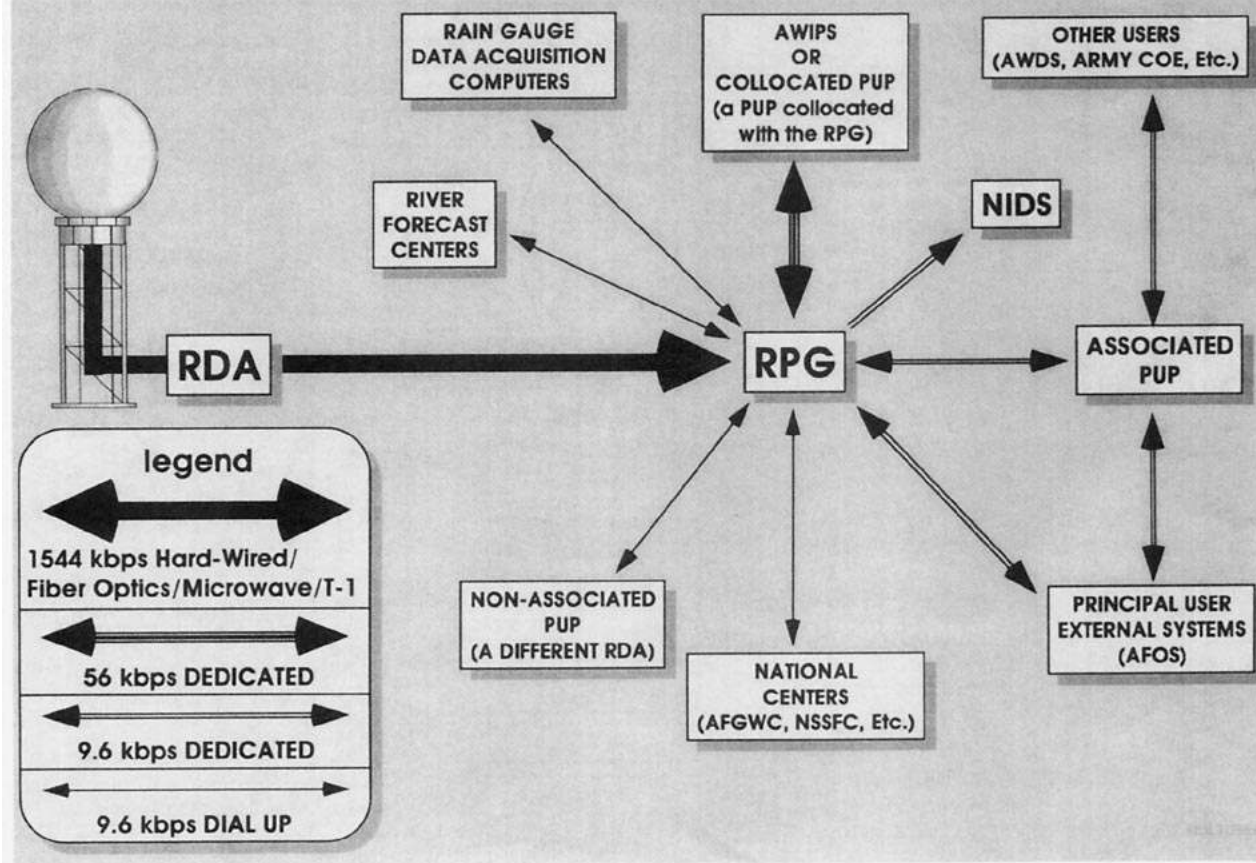

FIG. 5. WSR-88D RPG connections. Each RPG can be simultaneously connected to at least 31 users while continuously receiving data from the RDA via wideband communications.

workstation will display the WSR-88D data in the place of the PUP. PUPs will generally be associated with the nearest RDA and RPG from which they will receive PUP operator-selected products and algorithm outputs, updated every volume scan. In addition, a PUP operator can request, as a nonassociated PUP, products from any RPG via a temporary connection, although the local RPG operator controls access to the RPG. National Forecast Centers (National Meteorological Center, U.S. Air Force Global Weather Central, National Severe Storms Forecast Center, National Hurricane Center, River Forecast Centers, and Central Flow Control Facility) can connect to RPGs throughout the network of radars. Raingage data acquisition computers (external to the WSR-88D System) will transmit rain accumulation information to the nearby NWS RPG for use in updating precipitation accumulation products. Non-NEXRAD agency users can receive a predefined subset of WSR-88D products via one of

four NEXRAD Information Dissemination Service (NIDS) vendors (Baer 1991).

e. The Principal User Processor

The RPG passes products to PUPs, the workstations of the system. The host RPG will routinely send up to 20 products to an associated PUP during each volume scan. The PUP operator controls the list of products received. In addition, the PUP operator can request additional products on a "one-time" basis.

A PUP consists of a minicomputer, system console, color printer, graphics processor, workstation, and communications system. A PUP workstation (Fig. 6) has two 19-inch color graphic monitors, a graphic tablet and a puck (similar to a personal computer mouse), and an applications terminal. The PUP displays, manipulates, annotates, distributes, and locally stores products; controls and monitors the PUP system status; and records products (Level IV) the PUP

operator selects. Color graphics are used to depict up to 16 preselected quantization intervals of parameter values (reflectivity, mean radial velocity, echo-top heights, precipitation accumulation amounts, etc.).

A PUP operator uses the graphic tablet, puck, and applications terminal to select products, change parameters, and control the PUP's minicomputer. Products can be displayed and manipulated on a PUP in many ways to help the operator assimilate the large amount of information available. Examples of the display options the PUP operator has are to recenter the displays; magnify the displays by a factor of 2, 4, or 8; display four products per screen; link or unlink the cursors on the two screens; display up to 72 images in one of three time lapses; select various combinations of high-resolution map backgrounds and overlays; and define two distinct alert areas that will trigger an audible alarm if operator-selected criteria thresholds are exceeded.



FIG. 6. A WSR-88D PUP workstation. The forecaster/operator displays products on the twin 19-inch color monitors. The graphics tablet and puck are used to interact with the displays.

3. WSR-88D operations

a. Range considerations

Figure 7 illustrates the WSR-88D effective ranges of 460 km for reflectivity measurements and 230 km for velocity and spectrum width measurements. Due to beam widening and increasing height above the earth with increasing range, WSR-88D algorithms have been designed to process data appropriate for resolutions consistent with spatial scales of relevant meteorological phenomena.

b. Scan strategies

WSR-88D Systems will operate 24 hours a day. The sensitivity of the system is great enough that meteorologically useful data is received in situations ranging from clear air to severe storms. The antenna scans its environment in predefined sequences of 360° azimuthal sweeps at various elevation angles. A completed multiple elevation sequence of azimuthal sweeps is a "volume scan." Initially WSR-88D

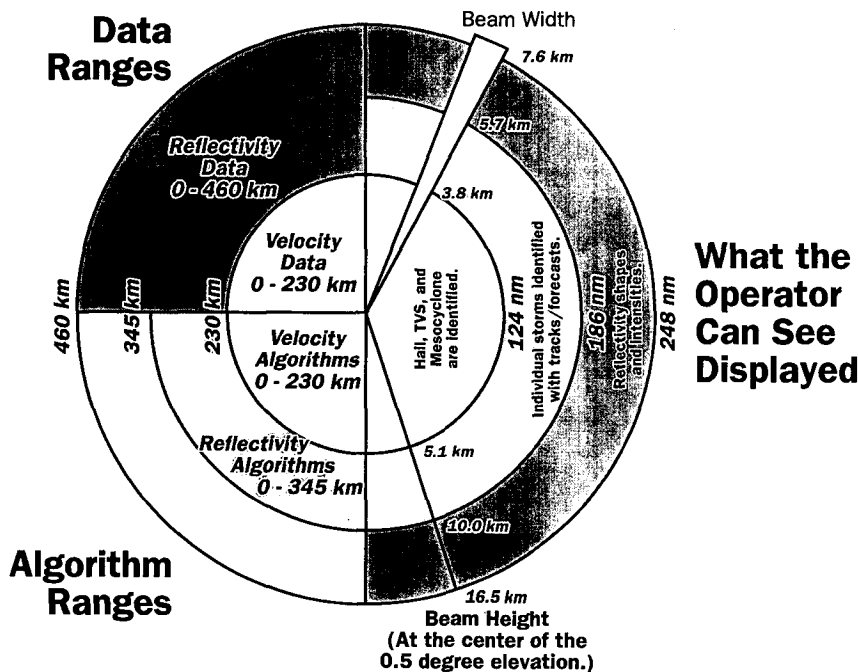

FIG. 7. Ranges at which WSR-88D data are received and meteorological algorithms are active. The entire suite of data, algorithms, and products is available out to 230 km. No velocity information is available beyond 230 km. Storms are identified, tracked, and locations forecast to the 345-km range. Between 345 km and 460 km, no algorithms are active, but reflectivity products are available. The width of the WSR-88D's 0.95° beam is depicted at various ranges along with the center of the beam height (accounting for propagation in the standard atmosphere and earth curvature) at an elevation angle of 0.5°.

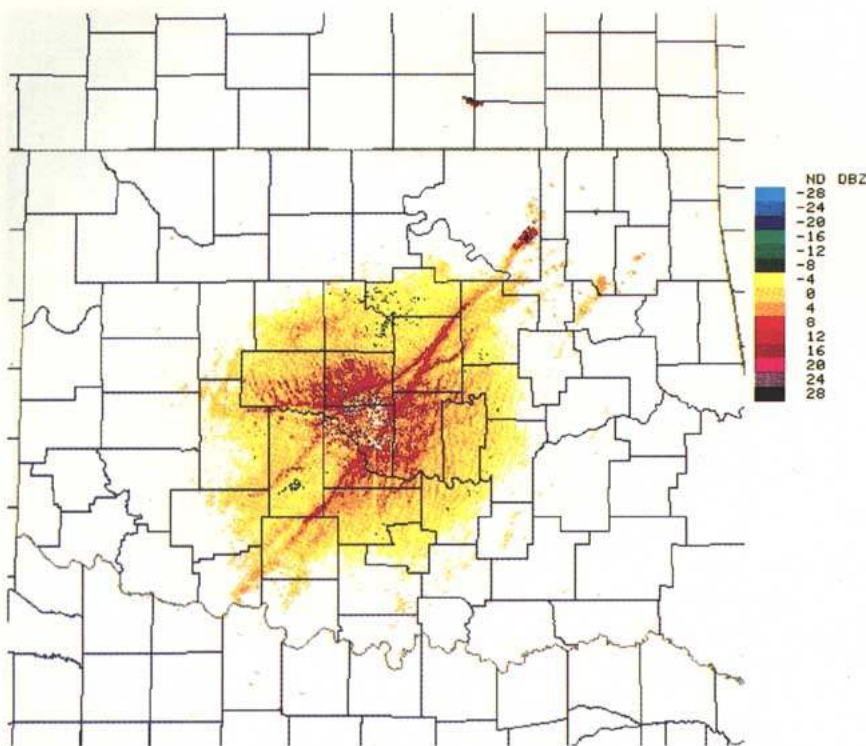

FIG. 8. Oklahoma City WSR-88D base reflectivity image at 2219 UTC on 2 July 1992 while in the clear-air scan strategy. The elevation angle is 0.5° . The color table on the right depicts the color code for the reflectivities in the image. The reflectivities displayed in the clear-air scan strategy range from -28 dBZ to more than 28 dBZ. The "line" of higher reflectivity values (red) oriented west to northeast, west and north of the radar (center of image), is a precipitation-free cold front. The southwest to northeast-oriented line of higher reflectivity values just south and east of the radar coincides with a discontinuity that developed during the day. Showers are developing northeast of the intersection of the boundaries. The other higher reflectivity values around the radar are clear-air returns and are due to refractive index gradients and particles in the lower troposphere.

are primarily for optimizing the performance of the meteorological algorithms. The parameters of the $Z-R$ relationship or shear criteria for triggering the mesocyclone algorithm are examples of these parameters.

- 2) Each WSR-88D System contains unique features that cause variations in the radar's performance. The approximately 600 engineering parameters adjust the radar's performance to meet the technical requirements. Most of these parameters are in the RDA. Parameters to define clutter filters, establish communications links, and modify range biases in some meteorological algorithms are examples of these parameters.
- 3) There are approximately 10 500 operational adaptable parameters. These parameters directly impact the performance of the system and indirectly affect the performance of the meteorological algorithms and products. Examples of the system functions affected by these parameters are product distribution control, PUP color

Systems will employ one of four volume scan strategies (determined by the operational needs of the NEXRAD agencies) that require 5 to 10 min to complete. Other scan strategies may be implemented in the future. Products are available for each individual azimuthal sweep as well as at the conclusion of each completed volume scan (some derived products use information from all or several azimuthal sweeps).

c. Adaptable parameters

The WSR-88D has parameters that optimize the system for varying geographical, climatological, and site-specific conditions and adjust the radar for different agency operational requirements. There are approximately 11 500 adaptable parameters in each WSR-88D System. The parameters can be categorized as "meteorological," "engineering," or "operational":

- 1) The approximately 400 meteorological parameters

scheme definition, and RPG product generation priority.

4. WSR-88D products

The WSR-88D System provides the operational meteorologist with state-of-the-art automation for processing Doppler weather radar data. Products are displayed in one or more of the following forms: color graphic images, graphic overlays, and alphanumeric. WSR-88D RPGs generate both base radar data products and products derived from meteorological and hydrological algorithms. There are 39 different fundamental products (appendix A) and many different combinations of products and displays available. For example, the mean radial velocities or reflectivities for each azimuthal sweep can be viewed, various products can be viewed

individually or on four-panel displays, various resolutions and ranges for reflectivity and velocity products are available, and derived products can be overlaid. The NEXRAD Algorithm Report (NEXRAD 1985) contains additional details on the meteorological algorithms. The FMH No. 11, Parts D and C, contain examples of these products. Klazura and Imy (1993) contains a table with more complete details of the products and examples of the products. Some of the WSR-88D base and derived products are described in the following subsections.

a. Reflectivity-based products

1) BASE REFLECTIVITY

Base reflectivity products generally depict a full 360° azimuthal sweep of data at a selected elevation angle (analogous to a plan position indicator display). Displays are available at 1° x 1-km resolution to a maximum range of 230 km, or at 1° x 2-km or 1° x 4-km resolution out to 460 km. The sensitivity of the WSR-88D System greatly exceeds that of the WSR-57 radar (minimum detectable signal at 50 km of approximately 13 dBZ_e for the

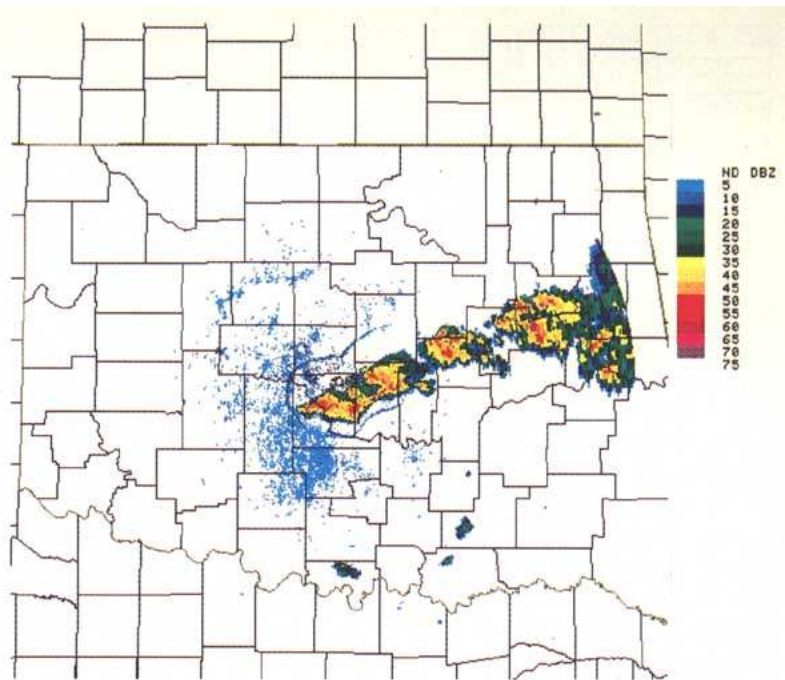

FIG. 9. The Oklahoma City WSR-88D base reflectivity at 2101 UTC on 22 June 1991 while in the precipitation scan strategy. The elevation angle is 0.5°. The reflectivities displayed range from 5 to 75 dBZ. The east–west line of convection just south of the radar (center of image) produced a downburst and gust front that can be seen as a line of enhanced reflectivity values (blue pixels) 10–30 km from the western third of the convection. The reflectivity values associated with the gust front are below the sensitivity of the WSR-57. A time lapse of base reflectivity clearly shows the movement of this gust front.

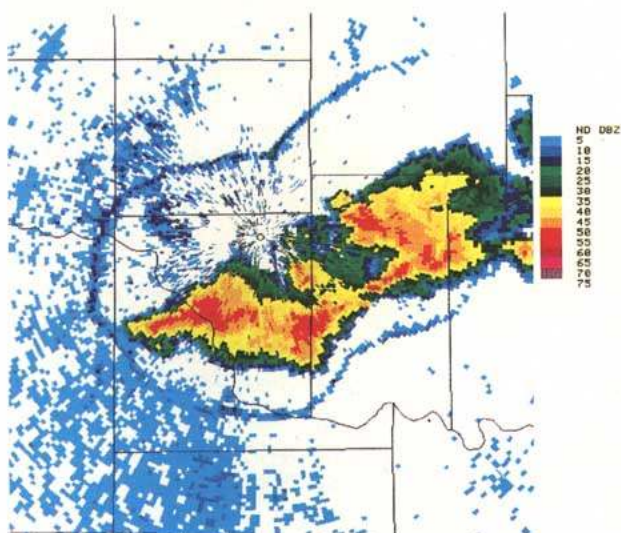

FIG. 10. As in Fig. 9, the Oklahoma City WSR-88D base reflectivity at 2101 UTC on 22 June 1991 and the elevation angle is 0.5°. This image, however, has been magnified by a factor of 4 to demonstrate the high spatial resolution and map background capability of the system. Additional map background overlays (e.g., cities, airports) can be displayed. As in Fig. 9, the gust front emanating from the region of convection is represented by the blue pixels that appear as a ring around the convection.

WSR-57 versus a reflectivity of -8 dBZ_e at 50 km for the WSR-88D). This increased sensitivity permits the display of meteorologically useful data in optically clear-air events. This increased sensitivity has already permitted operators to see and track land/sea breezes, river breezes, gust fronts, smoke plumes, birds, precipitation-free cold fronts, drylines, and other phenomena. Figure 8 demonstrates the increased sensitivity the WSR-88D offers in an optically clear-air situation. WSR-88D Systems frequently detect gust fronts created by thunderstorm downdraft outflow (Fig. 9). Coupled with the system's magnification capability, the spatial resolution of the WSR-88D is so fine that experience has demonstrated that forecasters can identify which portions of counties and cities a meteorological phenomenon will strike (Fig. 10).

2) COMPOSITE REFLECTIVITY

The composite reflectivity product depicts maximum gridded reflectivities detected within a complete volume scan. The product shows the maximum reflectivity found at any elevation projected onto a Cartesian geographical map with 1-km x 1-km resolution out to 230 km, or with 4-km x 4-km resolution out to 460 km.

STM ID	AZ	RAN	TUS	MESO	HAIL	DBZM	HGT	ULOW	STM TOP	FCST	MUMT	MW UOL
R	143	29	YES	YES	POS	61	7.6	30	41.47	257	39	16494
58	169	67	NO	YES	POS	65	13.2	87	44.53	254	33	33359
85	80	130	NO	NO	PRO	66	18.3	37	44.12	240	39	13416
76	76	93	NO	NO	PRO	57	10.7	34	29.83	242	43	2811

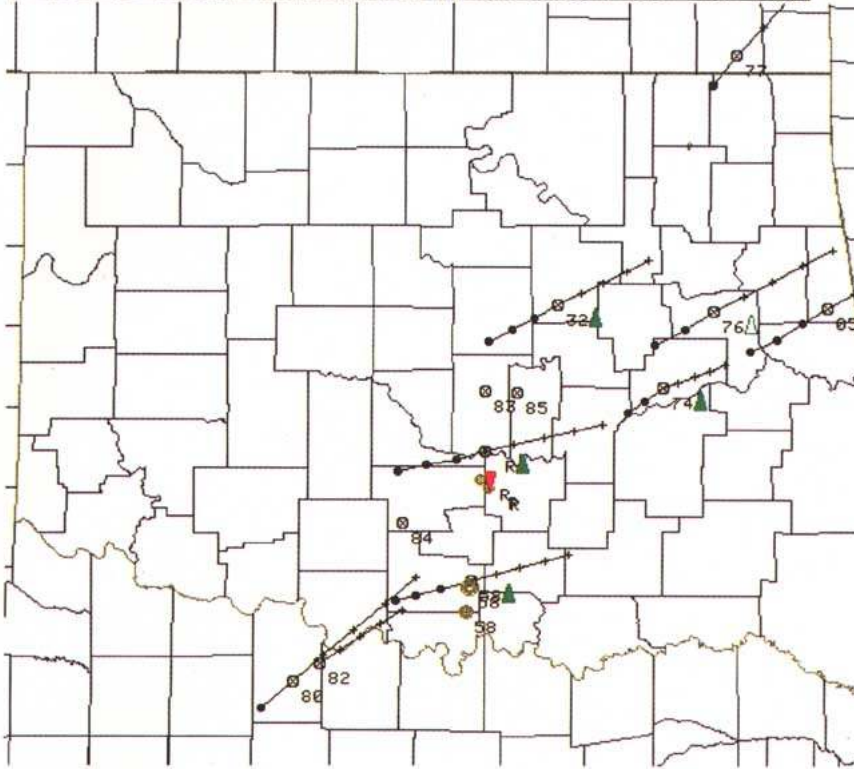

FIG. 11. An example of a WSR-88D overlay that contains some of the available products produced at 2207 UTC 21 March 1991. The base image, composite reflectivity, has been removed to enable the reader to better see the overlay. The overlay contains products of the storm series algorithm: cell identification (black circles containing an "x" with a cell identification code), the track of the past storm positions (black circles), and forecast storm positions (black crosses); the hail algorithm (green "triangle"), tornadic vortex signature algorithm (red "triangle"), and mesocyclone algorithm (yellow wreath). The attribute table at the top of the graphic provides an alphanumeric listing of information on the product overlays.

3) STORM SERIES

The storm series algorithms identify individual storms and create tracking and structural information. Tracks indicate the past movement of thunderstorm cells and project future storm paths for up to an hour (Fig. 11) at 15-min intervals.

4) HAIL INDEX

The hail index product is intended to indicate whether a storm's reflectivity structure is indicative of hail formation potential (Winston 1988). Indications of "probable" and "positive" hail-producing storms are displayed (Fig. 11) as guidance to assist the operator with identification of potentially damaging hailstorms.

5) REFLECTIVITY CROSS SECTION

The reflectivity cross-section product displays a

vertical cross section of reflectivity derived from a complete volume scan. The operator selects the beginning and ending points. This product is a major improvement on the range-height-indicator-type display because the operator is not limited to radially oriented cross sections. In addition, and most importantly, data collection on all other storms continues while this product is generated. This product is an important tool for analysis of a storm's structure and for identification of the height of maximum reflectivities, weak-echo regions, and storm tilt.

6) VERTICALLY INTEGRATED LIQUID

The vertically integrated liquid (VIL) product displays an estimate of the amount of liquid water (based on a reflectivity liquid water assumption) contained in a vertical column over each radar grid area (4 x 4 km). Large VIL values, which may imply strong updrafts, have been used to forecast severe weather events. The *severe weather probability* algorithm, a mapped display of probabilities of severe weather, is dependent on VIL-based predictors (Winston 1988).

7) WEAK-ECHO REGION

The weak-echo region product graphically displays the three-dimensional thunderstorm reflectivity structure. It is used to identify characteristics that are related to storm severity and expected cell lifetime, such as weak-echo regions, storm reflectivity cores, and storm tilt. This product displays reflectivity data for up to eight elevation angles for a user-selected region (50 km on a side) as a set of up to eight vertically stacked planes in perspective view.

8) ONE-HOUR, THREE-HOUR, AND STORM TOTAL RAINFALL ACCUMULATION

The RPG also produces precipitation products based on reflectivity. Graphical displays of one-hour, three-hour, and storm total rainfall accumulation (Fig. 12) products are available to WSR-88D users. The

WSR-88D precipitation processing software uses reflectivity data from the four lowest elevation angles of the volume scan (0.5°, 1.5°, 2.4°, and 3.4°) to create a composite "hybrid" scan that accounts for radar beam blockage due to terrain and man-made features. This hybrid scan is constructed after correcting for anomalously large reflectivity values (e.g., ground clutter, hail, bright band), isolated returns, and partial blockage of the beam. Rainfall rates and accumulations are based on a Z-R relationship that is adjustable. NWS WSR-88D Systems will be connected to raingage data acquisition computers that will provide a database of precipitation gauge reports. Where raingage data are available, these measurements are treated as calibration checks, and adjustments for the radar-based estimates (Kelsch 1989). WSR-88D digital precipitation

arrays (not displayable on PUPs) provide 1-h precipitation estimate input to NWS Forecast Office stage 2 precipitation processing (WSR-88D processing is considered stage 1 processing). The U.S. Army Corps of Engineers (COE) also use the digital precipitation arrays. The result of this processing (inclusion of additional gauge data and quality control checks) serves as input to stage 3 processing that is done at River Forecast Centers (Shedd and Smith 1991; Hudlow 1990). These outputs will assist River Forecast Center staff, flood forecasters, and water management specialists with important hydrological decisions. Stage 2 and stage 3 processing is done on computer systems external to the WSR-88D System.

b. Mean radial velocity-based products

WSR-88D Systems measure the mean radial motion of scatterers within the radar pulse volume (current operational radars do not have this capability). The system has the ability to detect the motion of precipitation particles, large cloud particles, and other scatterers. In addition, because of the system's high sensitivity, measurement of radial velocities are typically obtained even in optically clear air in the boundary layer. These frequent updates provide valuable information on short-lived, small-scale events such as tornadoes, mesocyclones, wind shear, and downbursts.

Current meteorological interpretations of radar returns rely, in part, on the characteristic shape of

precipitation-filled areas for indications of tornadic activity. These reflectivity patterns (hook echoes and appendages) frequently result in "false alarms" for indications of tornadic activity. WSR-88D Systems will have several velocity-based products that will help operators visualize the dynamic motions inside a storm.

1) MEAN RADIAL VELOCITY

Mean radial velocity products depict a full 360° azimuthal sweep of data at a selected elevation angle (Fig. 13). The radial velocity data are displayed at a 1° x 0.25-km resolution (to 60 km), 1° x 0.5-km resolution (to 115 km), or 1° x 1-km resolution (to 230 km).

2) SPECTRUM WIDTH

Spectrum width products display mean radial velocity spectrum width estimates at the same resolution as base velocity. Spectrum width data are related to the turbulence intensity as well as the mean wind shear across the beam (FMH No. 11, Part C, 1991b). This product is useful in locating boundaries such as gust fronts. Spectrum width may be a useful tool for locating mesocyclones and tornadoes when the phenomenon is smaller than the radar's beamwidth.

3) STORM RELATIVE VELOCITY

The storm relative velocity product subtracts the speed and direction of storm movement (either from user input or from motions computed by the storm tracking algorithm) from the base velocity and displays the result at 1° x 1-km resolution to 230 km, or in a user-selected 50-km x 50-km window area with a 1° x 0.25-km resolution. This product makes mesocyclone velocity signatures easier to locate. Figure 14 shows how this display depicts rotation in a thunderstorm.

4) MESOCYCLONE DETECTION

The mesocyclone detection algorithm identifies vertically correlated (and symmetrical) two-dimensional wind shear regions within a storm, commonly called "mesocyclones" (Fig. 11) (Hennington and Burgess 1981). The occurrence of mesocyclones is highly correlated with severe weather (Burgess and Lemon 1990). The *tornadic vortex signature* (TVS) algorithm, similar to the mesocyclone detection algorithm, searches for intense smaller-scale circulations embedded in the mesocyclone. The TVS algorithm is

... The four-panel severe weather analysis display ... provides, at the highest product resolution available, four separate maps of reflectivity, mean radial velocity, spectrum width, and radial shear for 50-km by 50-km areas.

designed to alert the user to areas that indicate a very high threat of tornadic circulations.

5) VELOCITY CROSS SECTION

The velocity cross-section product displays a vertical cross section of radial velocities derived from a complete volume scan. This product permits an operator to interrogate individual storms for the presence and strength of convergence or divergence patterns, which are important keys to the stages in a storm's life cycle, and examine the depth and strength of mesocyclones. Thunderstorms develop and sustain themselves through low-level (below 3 km altitude) mass convergence and upper-level (above 6 km altitude) mass divergence. Dramatic instances of these correlated patterns, which are associated with severe thunderstorms, have been detected and displayed by WSR-88D Systems (Fig. 15).

Just like the NEXRAD program, the OSF depends on the cooperation and support of the three sponsoring agencies. The five OSF branches are staffed with U.S. Air Force, Navy, DOC/NWS, and contractor personnel.

6) VELOCITY AZIMUTH DISPLAY WIND PROFILES

Velocity azimuth display wind profiles (VWP) products depict a vertical profile of wind speed and direction derived from radial velocity measurements (Fig. 16). This capability allows the user to monitor changes in the wind structure of the atmosphere with 5- to 10-min update rates. This significantly improves the current 12-h updates from rawinsondes and even the hourly updates of profilers. As an example, the VWP product has already shown the dramatic development of a low-level jet where the velocities at 1500 ft altitude increased from 30 kt to 65–70 kt in less than 3 h.

Another WSR-88D display available to PUP operators to aid their understanding of the atmosphere's structure is the four-panel *severe weather analysis* display. This display provides, at the highest product resolution available, four separate maps of reflectivity, mean radial velocity, spectrum width, and radial shear for 50-km by 50-km areas. The user can select the product center point coordinates and elevation angle or the product may be generated automatically for a specified alert criterion. The display allows the operator to see the radar moments for an area of interest, usually an intense/severe storm, on a single screen without having to page through multiple products. The PUP operator can also display other products on the other graphics screen.

The severe weather analysis display illustrates the

system's four-panel display capability that allows the operator to view multiple products on each graphics screen. This can be a very effective technique for evaluating the vertical structure of a storm. By simultaneously displaying reflectivity or velocity products at up to four different elevation angles on each screen, the operator can make direct comparisons of the low-, middle-, and high-level storm structures (Fig. 17). PUP operators can use another helpful system capability, the macrolike user function, to easily create these four-panel displays. Once defined, the user function allows the operator to press a single button to quickly perform the multiple actions that would have been required to manually produce the four-panel displays.

These, among other base and derived products, provide the WSR-88D operator with many timely forecast aids that assist in the warning and forecast decision process.

5. The WSR-88D Operational Support Facility

The OSF will be responsible for supporting the WSR-88D System during its operational life. This support includes developing, testing, and implementing changes and enhancements to the WSR-88D System.

a. OSF staffing

Just like the NEXRAD program, the OSF depends on the cooperation and support of the three sponsoring agencies. The five OSF branches (Fig. 18) are staffed with U.S. Air Force, Navy, DOC/NWS, and contractor personnel. OSF staffing began in late 1988 and was principally completed during 1993. The OSF is administratively assigned to NOAA. Guidance for the OSF and its activities are, however, provided by all three user agencies. Major program issues are approved by the triagency NEXRAD Program Council and NEXRAD Program Management Committee.

b. OSF mission

The mission of the OSF is to provide support to operational WSR-88D Systems. To meet this mission, the OSF has four principal responsibilities:

1) PROVIDE OPERATIONAL SUPPORT

The WSR-88D will significantly improve on the current ability of the weather services to collect and

interpret vital weather data. To achieve this improvement, however, the operational users will need to understand and properly use the WSR-88D System's new capabilities, interpret the information provided, incorporate the radar data into forecast/warning services, and properly maintain the system. The OSF will provide operational support in these areas through two primary means.

(i) *Field support hotline.* The principal contact operational users will have with the OSF is via the field support hotline. The hotline is staffed around the clock by both a maintenance specialist and an operations specialist. They have access to the OSF WSR-88D Systems, the capability to connect remotely for product access to any RPG, access to all WSR-88D technical documentation, and a computer database containing all solutions provided to previous hotline callers. The hotline will assist field sites on request with maintenance problems, procedural problems, software questions, and product interpretation. However, decisions concerning whether or not to issue warnings or advisories using the data remain the responsibility of the field site.

(ii) *Field maintenance assistance.* In instances where maintenance needs exceed local capabilities, the OSF will assist field sites in correcting special maintenance problems (e.g., catastrophic failure). The OSF will also assist with special on-site "depot level" maintenance.

2) CONTROL THE WSR-88D BASELINE

The OSF will control the WSR-88D System baseline to ensure smooth, efficient operations. Only approved software and hardware may be used on a WSR-88D System.

Sites may submit requests for changes to the WSR-88D baseline through their headquarters. Based on the expense and impact of the change, the request will be approved/disapproved by the OSF Configuration Control Board or the NEXRAD Program Management Committee. Once requests have been approved, the OSF will make the changes, thoroughly test them to ensure they meet the change criteria, update technical documentation, and send the new baseline to the field with implementation instructions.

The OSF will maintain the official baseline version of the WSR-88D technical documentation, technical drawings, software, adaptable parameters, operating procedures, and hardware.

3) ENHANCE THE WSR-88D SYSTEM

Throughout the operational life of the WSR-88D System, the OSF will conduct and monitor activities to enhance the system's performance. These enhancements will come from a multitude of sources—operational users, contractors, researchers, and OSF personnel. The OSF will thoroughly test all enhancements before they are implemented at operational sites.

Lessons learned from operational experience with the WSR-88D and changing requirements will lead to hardware changes. Enhancements to the WSR-88D hardware may be made to take advantage of new and increased capabilities available through advances in hardware technology.

There are approximately 430 000 lines of executable software in the baseline WSR-88D System. Software changes will be necessary to implement hardware changes, new products, new capabilities, and enhancements requested by the user agencies.

Enhancement of meteorological algorithms and products will require joint efforts involving the user agencies, the research and development community, and the OSF. The strategy for developing these enhancements is discussed in section 6.

The products the PUP user displays may require changes or new products based on new meteorological algorithms or human factor considerations. The Applications Branch will employ human factors engineering to facilitate operating the PUP more efficiently.

4) TRAIN OPERATORS

Members of the Operations Training Branch (NWS and DOD instructors) conduct a 4-week WSR-88D operations training course at the OSF. Students train on WSR-88D equipment and have limited access to the OSF WSR-88D Systems. All NWS forecasters will attend the course. Through 1994, the DOD will send students to the class. The DOD operations training course at the Keesler AFB training center begins in 1993. Mobile training teams train DOD operators in the field.

Throughout the operational life of the WSR-88D System, the OSF will conduct and monitor activities to enhance the system's performance. These enhancements will come from a multitude of sources—operational users, contractors, researchers, and OSF personnel.

6. WSR-88D meteorological algorithm enhancements

As depicted in Fig. 4, the WSR-88D System executes algorithms that use base data to produce a wide variety of meteorological and hydrological products. The algorithms in the baseline WSR-88D were developed by researchers in the 1970s and early 1980s using data from a limited number of geographic locations. A discussion of these algorithms can be found in the NEXRAD Algorithm Report (NEXRAD 1985). Enhanced and new meteorological algorithms are expected to be developed as operational experience and research lead to the improved use of the base data to provide more reliable meteorological algorithms and products. The research will be conducted by the NEXRAD agencies, groups under contract to the OSF or NEXRAD agencies, and independent researchers.

The OSF Applications Branch will conduct proof of concept testing of enhancements to existing and new meteorological algorithms and products. The branch will also serve as the focal point for meteorological algorithm and product developments, and interactions with the research and development (R&D) community. One such activity will be to assist with the transition of new or enhanced algorithms and products into the WSR-88D System.

The NEXRAD Technical Advisory Committee (TAC), an advisory body, is composed of representatives from the three user agencies and two at-large members. The TAC provides a mechanism for community-wide coordination of WSR-88D technical needs. As their principal responsibility, the TAC will do the following:

- 1) Set priorities for WSR-88D technical needs that require R&D work. The TAC will consider feasibility of the R&D required and will communicate the program's technical needs to the R&D community;
- 2) Annually distribute the technical needs priority list to R&D organizations and field users;
- 3) Evaluate the technical merit of proposed enhancements;
- 4) Provide technical advice and conduct independent technical reviews of critical issues. The TAC will

solicit technical advice from sources outside the NEXRAD program.

Development and testing of WSR-88D data acquisition/processing hardware and software enhancements will require many varied WSR-88D datasets. Such datasets will also be of great value to researchers who are working on projects independent of WSR-88D development. Two levels of WSR-88D digitized data (Levels II and III) will be collected and archived (Crum et al. 1993). Level II data—reflectivity, mean

radial velocity, spectrum width, and system status data—will provide the primary information required for development, testing, and training. These base data, collected at selected operational WSR-88D sites, will be archived at and available for distribution from the National Climatic Data Center. Level III data contain the base and derived products of the meteorological algorithms executed in the RPG. *Federal Meteorological Handbook No. 11,*

Part A, (1991a) specifies the routine product sets that will be collected on Level III at NWS sites. The National Climatic Data Center will archive and distribute these datasets.

NEXRAD agency groups, as well as those outside the program, will play a vital role in the ongoing quest to improve the WSR-88D System's capabilities to observe the mesoscale atmosphere and to transform those data into information useful to operational forecasters. The cooperation and support of the R&D community will be vital to the continued successful implementation of an ever-expanding capability of WSR-88D Systems.

NEXRAD agency groups, as well as those outside the program, will play a vital role in the ongoing quest to improve the WSR-88D System's capabilities to observe the mesoscale atmosphere and to transform those data into information useful to operational forecasters. The cooperation and support of the R&D community will be vital to the continued successful implementation of an ever-expanding capability of WSR-88D Systems.

7. Summary

WSR-88D Systems will provide a major improvement to existing weather radar detection capabilities. Principal improvements include Doppler capability, improved spatial resolution, and greater system sensitivity. The WSR-88D System will substantially enhance our capability to detect severe thunderstorms and will enable forecasters to provide more accurate warnings with longer advance notice than is now possible. In addition, WSR-88D Systems will enable

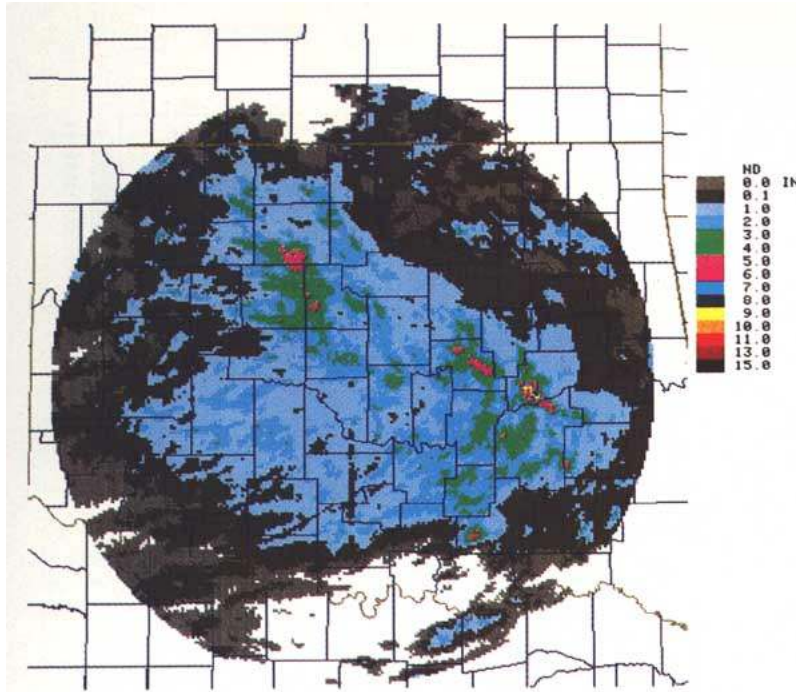

FIG. 12. The Oklahoma City WSR-88D storm total radar-estimated precipitation accumulation beginning at 2108 UTC 2 July and ending at 0051 UTC 4 July 1991. The accumulation estimates are in inches.

- Composite reflectivity contour
- Cross section—reflectivity
- Cross section—velocity
- Cross section—spectrum width
- Echo tops
- Echo-tops contour
- Hail index
- Layer composite reflectivity—average
- Layer composite reflectivity—maximum
- Layer composite turbulence—average
- Layer composite turbulence—maximum
- Mean radial velocity
- Mesocyclone
- One-hour digital precipitation array
- One-hour precipitation accumulation
- Radar coded message
- Severe weather probability
- Severe weather analysis—reflectivity
- Severe weather analysis—radial shear
- Severe weather analysis—velocity
- Severe weather analysis—spectrum width
- Spectrum width
- Storm relative mean radial velocity (map)

earlier detection and warnings of threatening wind conditions (even in optically clear air) and the potential for devastating floods. WSR-88D Systems will also provide extremely valuable information for water resource management decisions that, although perhaps less dramatic, are becoming increasingly important to our nation.

The triagency nature of the NEXRAD program will continue through the OSF's life-cycle support of the WSR-88D System. The OSF will work with the operating agencies to ensure effective operation, maintenance, and enhancement of the WSR-88D System.

Acknowledgments. The authors thank the OSF staff and many other formal and informal reviewers of this manuscript for their suggestions. Jeff Fornear developed many of the drawn figures. Jeff Manion assisted in the production of the WSR-88D imagery.

Appendix A: WSR-88D Products

- Base reflectivity
- Combined moment
- Combined shear
- Combined shear contour
- Composite reflectivity

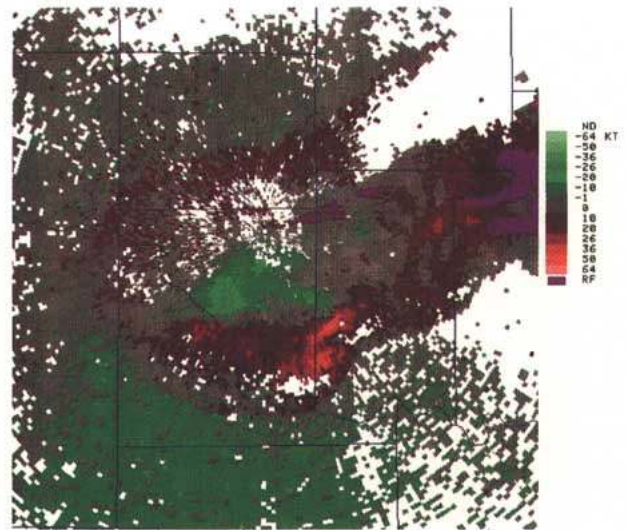

FIG. 13. The Oklahoma City WSR-88D base velocity (1-km resolution) at 2101 UTC 22 June 1991. The elevation angle is 0.5°. The color legend is on the right. The green colors indicate mean motion toward the radar (center of the image). The shades of red indicate mean motion away from the radar. Purple indicates range-folded values. This image corresponds (with a magnification factor of 4) to the base reflectivity image of the gust front in Figs. 9 and 10. Note that the radial velocities south of the radar (from the center out) are inbound, outbound, and inbound as the beam passes from northbound downdraft outflow to southbound downdraft outflow (at the thunderstorm outflow center) to southerly environmental flow. The gust front has passed to the north of the radar site as indicated by the northbound flow north of the radar site.

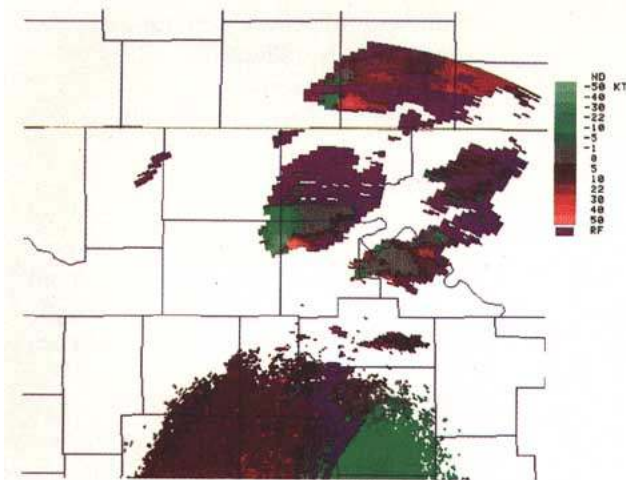

FIG. 14. The Oklahoma City WSR-88D storm relative velocity (the mean storm motion has been subtracted from all radial velocities) at 2333 UTC 26 April 1991 during a violent tornado outbreak in the central Great Plains. The elevation angle is 0.5° and the image has been magnified by a factor of 2. There are two main storms almost due north of the radar, one centered 130 km (74 n mi) north of the radar and the other 198 km (107 n mi) north of the radar. A tornado associated with the southern storm had been on the ground for about 3 min and was intensifying. The tornado was on the ground for 66 mi, reaching F4 intensity with a path width of about 1 km. A tornado associated with the northern storm had also been on the ground for about 3 min. It remained on the ground for 25 mi and reached F4 intensity. The strong radial shear (green/inbound air next to the red/outbound air) associated with both cells depict rotation (mesocyclones).

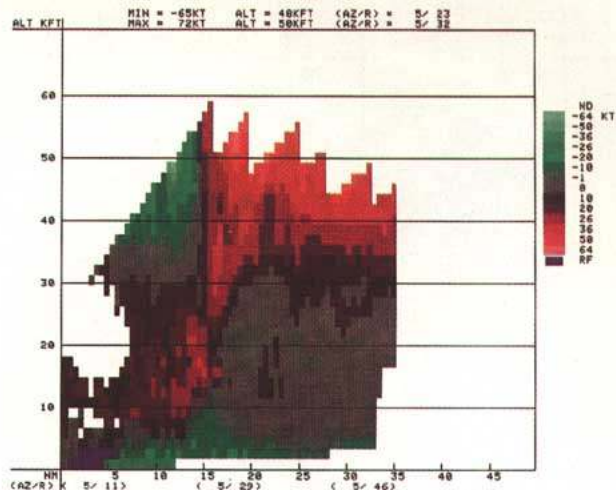

FIG. 15. The cross section of radial velocities from the Oklahoma City WSR-88D looking out the 5° radial at 2213 UTC 1 September 1989. Range from the radar (n mi) is along the x axis and height above the radar (k ft) is along the y axis. The colors are as depicted in Figs. 13 and 14. The low-level storm outflow (green color) is being overridden aloft by the flow that is feeding the updraft (red color). Note the updraft's low-level convergence pattern at approximately 24 km (13 n mi) that extends to 3 km (10 k ft). Above this point [9.1 km (30 k ft)], the imagery indicates storm-top divergence at the summit of the updraft. The "staircase" appearance of the data top inside 28 km (15 n mi) indicates the edge of the highest antenna sweep. The "staircase" appearance of the storm top beyond 28 km (15 n mi) is due to the interpolation of data from successively lower azimuthal sweeps of the antenna.

Storm relative mean radial velocity (region)
 Storm structure
 Storm track information
 Storm total precipitation accumulation
 Supplemental precipitation data
 Three-hour precipitation accumulation
 Tornadic vortex signature
 Velocity azimuth display
 Velocity azimuth display wind profile
 Vertically integrated liquid
 Weak-echo region

FAA Federal Aviation Administration
 FMH Federal Meteorological Handbook
 IOTF Interim Operational Test Facility
 JDOP Joint Doppler Operational Project
 JSPO Joint System Program Office
 kbits kilobits
 kW kilowatts
 Mbits megabits
 MHz megahertz
 NEXRAD Next Generation Weather Radar
 NIDS NEXRAD Information Dissemination Service
 NOAA National Oceanic and Atmospheric Administration
 NSSL National Severe Storms Laboratory
 NWS National Weather Service
 OSF Operational Support Facility
 PUP Principal User Processor
 RDA Radar Data Acquisition
 RPG Radar Product Generator
 rms Root-mean-square
 R&D Research and development
 STI Storm tracking information
 TAC Technical Advisory Committee

Appendix B: Acronyms

AFB Air Force Base
 AFOTEC Air Force Operational Test and Evaluation Center
 AWIPS Automated Weather Interactive Processing System
 COE U.S. Army Corps of Engineers
 DOC Department of Commerce
 DOD Department of Defense
 DOT Department of Transportation

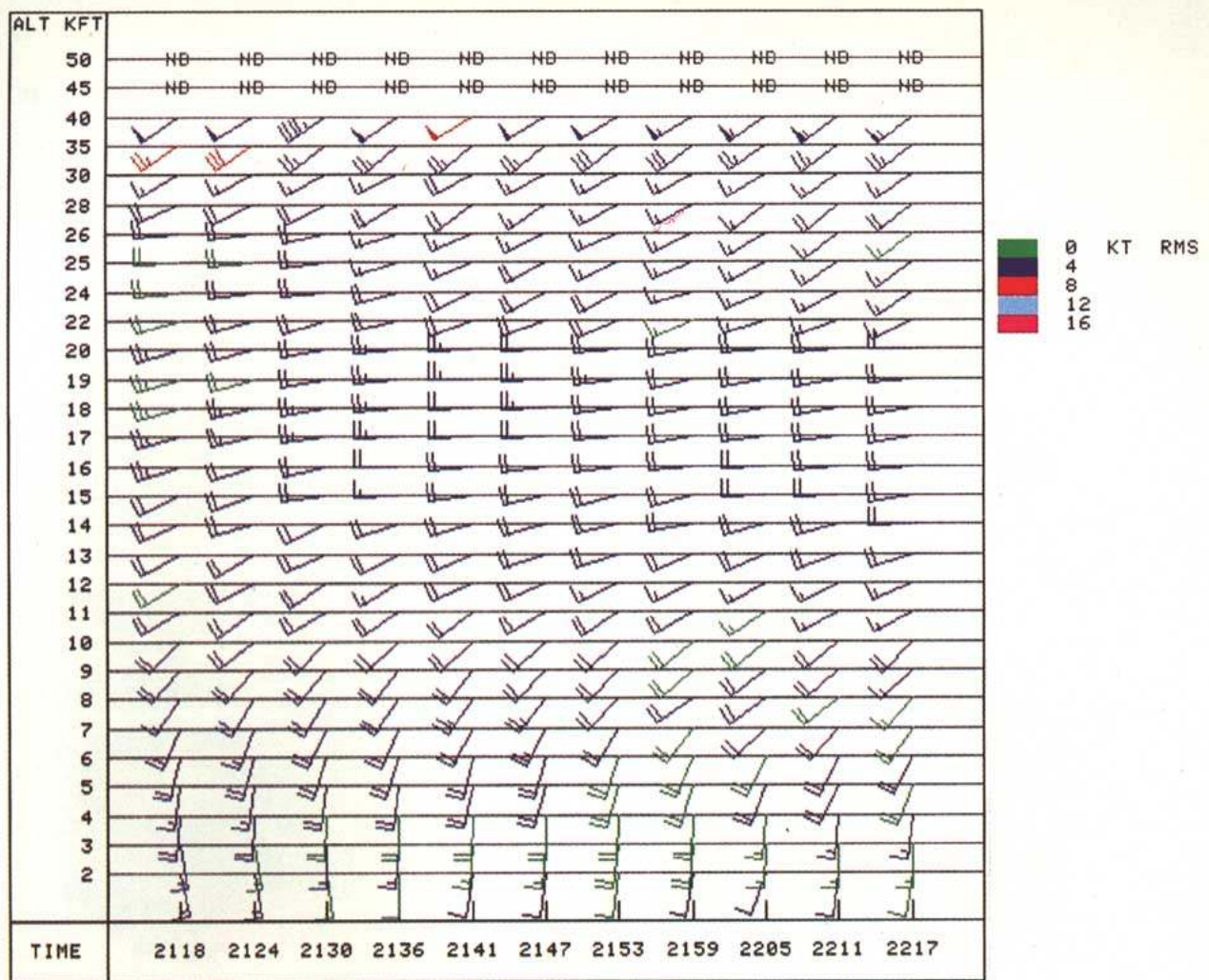

FIG. 16. The Oklahoma City WSR-88D velocity azimuth display (VAD) wind profile product from 2118 to 2217 UTC 16 April 1992. Wind barb plotting is conventional. The colors indicate rms (root-mean-square error) and are a measure of the fit of the measured velocity values to a sine wave approximation. The ND is annotated at heights where there is insufficient data.

UCP Unit control position
 UTC Universal Coordinated Time
 VAD Velocity azimuth display
 VIL Vertically integrated liquid
 VWP Velocity wind profile
 WSR-88D Weather Surveillance Radar—1988
 Doppler

References

- Alberty, R. L., T. D. Crum, and F. Toepfer, 1991: The NEXRAD program: Past, present, and future—A 1991 perspective. Preprints, *25th Intl. Conf. on Radar Meteorology*, Paris, Amer. Meteor. Soc., 1–8.
- Baer, V. E., 1991: The transition from the present radar dissemination system to the NEXRAD Information Dissemination Service (NIDS). *Bull. Amer. Meteor. Soc.*, **72**, 29–33.
- Burgess, D. W., and L. R. Lemon, 1990: Severe thunderstorm detection by radar. *Radar in Meteorology*, D. Atlas, Ed., Amer. Meteor. Soc., 619–647.
- Crum, T. D., R. L. Alberty, and D. W. Burgess, 1993: Recording, archiving, and using WSR-88D data. *Bull. Amer. Meteor. Soc.*, **74**, 645–653.
- Federal Meteorological Handbook No. 11*, 1990: Doppler radar meteorological observations, Part B, Doppler radar theory and meteorology. FCM-H11B-1990, Interim Version One. Office of the Federal Coordinator for Meteorological Services and Supporting Research, Rockville, Maryland, 228 pp.
- , 1991a: Doppler radar meteorological observations, Part A, System concepts, responsibilities, and procedures. FCM-H11A-1991, Interim Version One. Office of the Federal Coordinator for Meteorological Services and Supporting Research, Rockville, Maryland, 58 pp.
- , 1991b: Doppler radar meteorological observations, Part C, WSR-88D products and algorithms. FCM-H11C-1991, Interim Version One. Office of the Federal Coordinator for Meteorological Services and Supporting Research, Rockville, Maryland, 210 pp.

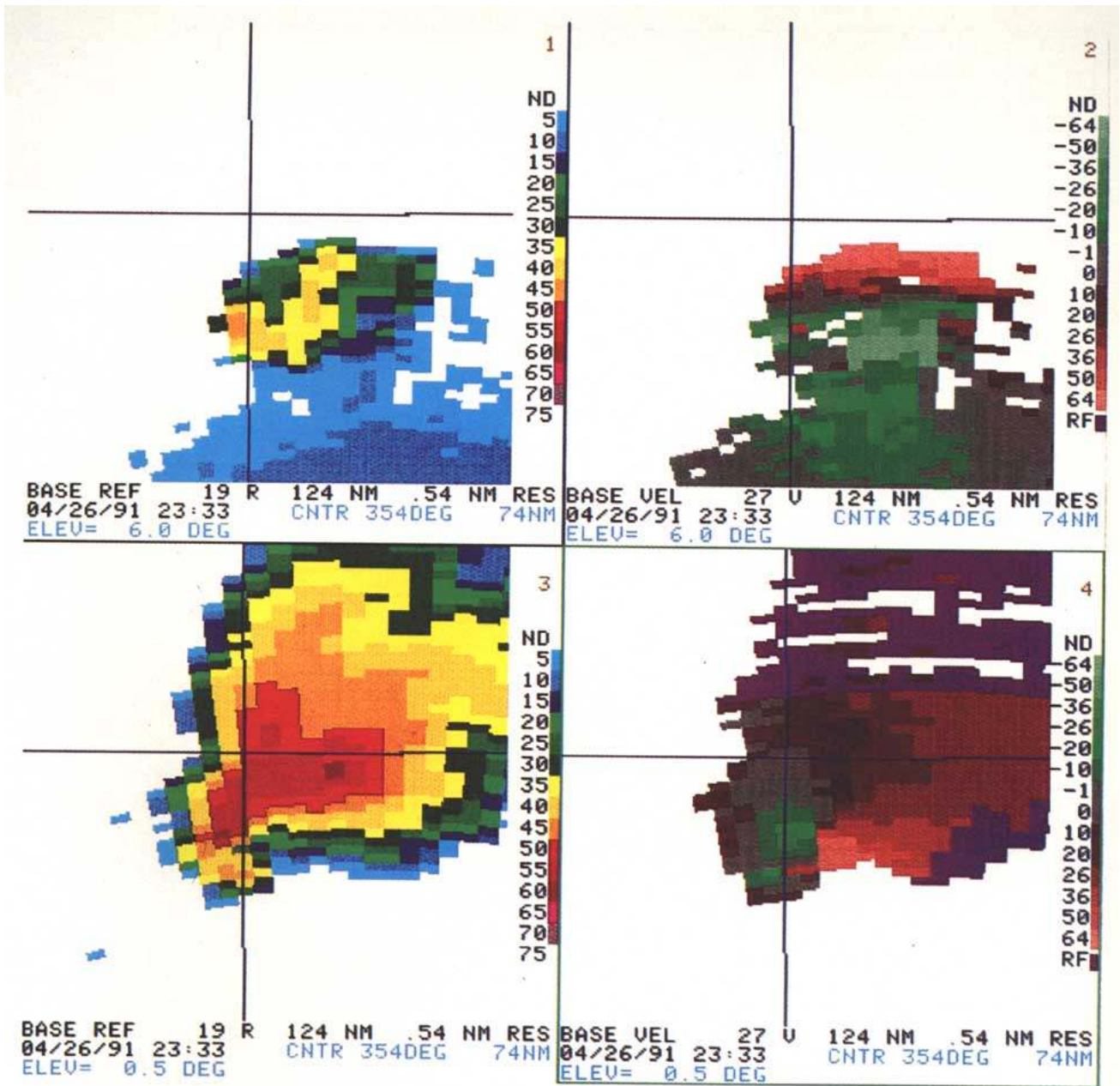

FIG. 17. A four-panel display created by a PUP operator that demonstrates the WSR-88D flexibility to display graphical products. These data from the Oklahoma City WSR-88D at 2333 UTC 26 April 1991 (same as Fig. 14) have been magnified by a factor of 8. These products show the structure of a tornadic thunderstorm associated with the large outbreak of severe weather in northern Oklahoma and southern Kansas. The four-panel display constructed here allows the PUP operator to contrast base reflectivity data (left column) with mean radial velocity data (right column) and for two elevation angles (0.5° and 6.0°). The intersecting county borders (center of image) serve as a reference point. The tilt of the storm to the south with height is evident when contrasting the location of the reflectivity data. The hook echo shape of the 0.5° reflectivity data corresponds to the region of strongest radial shear (the mesocyclone). The velocity signature at 6.0° (16.4 km/54 k ft AGL) shows the strong divergence associated with the supercell updraft. The area of reflectivities and velocities to the south of the thunderstorm core at 6.0° is due to the cirrus anvil.

—, 1992: Doppler radar meteorological observations, Part D, WSR-88D unit description and operational applications. FCM-H11D-1992, Interim Version One. Office of the Federal Coordinator for Meteorological Services and Supporting Research, Rockville, Maryland, 208 pp.

Forsyth, D. E., M. J. Istok, T. D. O'Bannon, and K. M. Glover, 1985: The Boston area NEXRAD demonstration (BAND). Air Force Geophysics Laboratory TR-85-0098. Hanscom AFB, Massachusetts, 59 pp.

Heiss, W. H., D. L. McGrew, and D. Sirmans, 1990: NEXRAD: Next

generation weather radar (WSR-88D). *Micro-wave J.*, **33**, 79–98.

Hennington, L. D., and D. W. Burgess, 1981: Automatic recognition of mesocyclones from single Doppler radar data. Preprints, *20th Conf. on Radar Meteor.*, Boston, Amer. Meteor. Soc., 704–706.

Hudlow, M. D., 1990: Modern era of rainfall estimation. Preprints, *Intl. Symp. on Remote Sensing and Water Resources*, Enschede, The Netherlands, Intl. Assoc. of Hydrogeologists, 53–63.

Joint Doppler Operational Project (JDOP), 1979: Final Report on the Joint Doppler Operational Project. NOAA Tech. Memo. ERL NSSL-86, Norman, Oklahoma, 84 pp.

Kelsch, M., 1989: An evaluation in the NEXRAD hydrology sequence for different types of convective storms in northeastern Colorado. Preprints, *24th Conf. on Radar Meteorology*, Tallahassee, Amer. Meteor. Soc., 207–215.

Klazura, G. E., and D. A. Imy, 1993: A description of the initial set of analysis products available from the NEXRAD WSR-88D System. *Bull. Amer. Meteor. Soc.*, **74**, 1293–1311.

—, T. D. Crum, and R. L. Alberty, 1992: The WSR-88D and its applicability to water resources data collection. *Managing Water Resources During Global Change*, Amer. Water Res. Assoc., 33–46.

Leone, D. A., R. M. Endlich, J. Petriceks, R. T. H. Collis, and J. R. Porter, 1989: Meteorological considerations used in planning the NEXRAD network. *Bull. Amer. Meteor. Soc.*, **70**, 4–13.

Next Generation Weather Radar (NEXRAD), 1980: Joint Program Development Plan, NEXRAD Joint System Program Office, Silver Spring, Maryland, 102 pp.

—, 1984: Results of Spring 1983 Demonstration of Prototype NEXRAD Products in an Operational Environment. NEXRAD Joint System Program Office, Silver Spring, Maryland, 109 pp.

—, 1985: Algorithm Report. NEXRAD Joint System Program Office, Silver Spring, Maryland, 738 pp.

Shedd, R. C., and J. A. Smith, 1991: Interactive precipitation processing for the modernized National Weather Service. Preprints, *Seventh International Conference on Interactive Information and Processing Systems for Meteorology, Oceanography, and Hydrology*, New Orleans, Amer. Meteor. Soc., 320–323.

Winston, H. A., 1988: A comparison of three radar-based severe-storm-detection algorithms on Colorado high plains thunderstorms. *Wea. Forecasting*, **3**, 131–140.

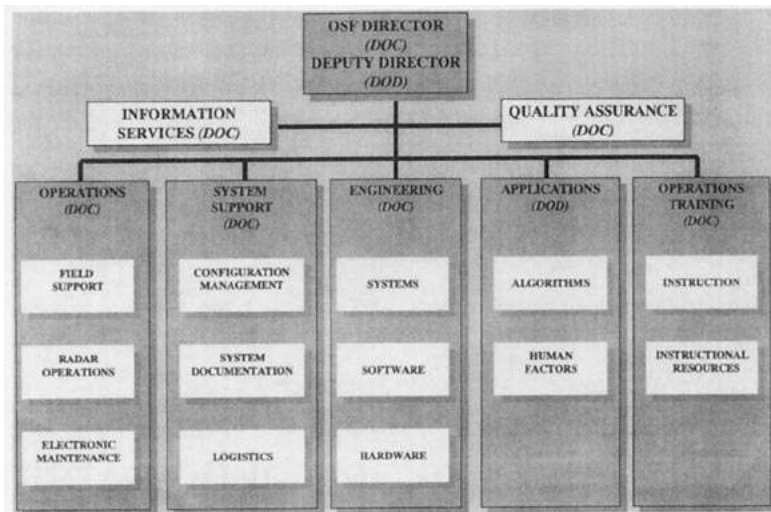
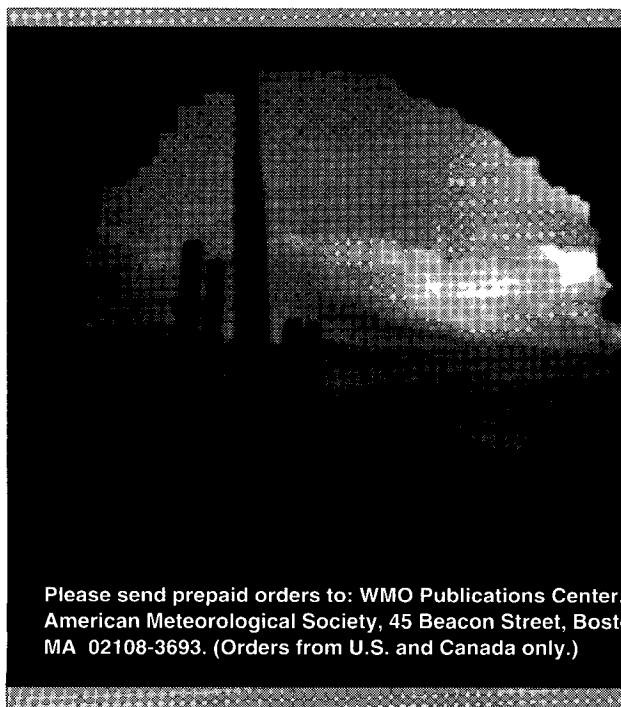

FIG. 18. The WSR-88D OSF organization. The major functions of each branch are listed along with the agency affiliation [Department of Defense (DOD) or Department of Commerce (DOC)] of each branch chief.



WMO PUBLICATIONS

● *Marine Cloud Album*

38 color pictures of cloud formations found at sea, of particular value to ships' officers, professional marine cloud observers, and yachting enthusiasts. \$25 includes shipping and handling.

● *Cloud Sheet*

Poster, 39 x 83 cm illustrating 38 different cloud formations. Attractive educational document particularly suited for the classroom, and places accessible to cloud observers, professional or amateur. \$10 includes S&H.

● *Climatic Atlases*

(Maps of mean temperature and precipitation)

Europe	182
South America	207
North and Central America	182
Asia	212

(above prices include shipping and handling)

Please send prepaid orders to: WMO Publications Center, American Meteorological Society, 45 Beacon Street, Boston, MA 02108-3693. (Orders from U.S. and Canada only.)