Thematic Relations as Links between Nominal Reference and Temporal Constitution

MANFRED KRIFKA

This paper treats the correspondence between the reference type of NPs (i.e., mass nouns, count nouns, measure constructions, plurals) and the temporal constitution of verbal predicates (i.e., activities, accomplishments). A theory will be developed that handles the well known influence of the reference type of NPs in argument positions on the temporal constitution of the verbal expressions, assuming an event semantics with lattice structures and thematic roles as primitive relations between events and objects. Some consequences for the theory of thematic roles will be discussed, and the effect of partitive case marking on the verbal aspect, as in Finnish, and of aspectual marking on the definiteness of NPs, like in Slavic, will be explained.

1 Introduction

It has been observed for some time that semantic distinctions in the nominal domain and in the verbal domain show certain resemblances to each other, namely the distinction between mass and count terms on the one hand and the distinction between “aspectual classes” or “aktionsarten” on the other.

Concerning the nominal domain, I think that one should not contrast mass nouns like *wine* to count nouns like *apple* directly, because they dif-

The theory developed in this paper represents parts of my doctoral thesis at the University of Munich (Krifka 1986). I learned a lot from my supervisors, Theo Vennemann and Godehard Link. And there are many more people who helped to clarify my ideas and their presentation: Rainer Bäuerle, David Dowty, Hana Filip, Franz Guenther, Sebastian Löbner, Jan Tore Lønning, Uwe Mönnich, Barbara Partee, Craige Roberts, Arnim von Stechow, Henk Zeevat, Barbara Zimmermann, Ede Zimmermann, and surely more. Thanks to them all.

- (3) a. John saw a zebra (for an hour)/(**in an hour*).
 b. John saw zebras (for an hour)/(**in an hour*).

This suggests that the lexical semantics of the verb plays a crucial role in the way the nominal reference type of the arguments affects the temporal constitution of the complex expression. More specifically, it seems that the *thematic role* of the argument is responsible for this effect; for example, we find it with arguments which can be described as “consumed object” as in (2), but not with arguments which can be described as “observed objects” as in (3). Therefore, a theory which explains this effect will have consequences for the theory of thematic roles.

Some historical remarks: The similarity between nominal and verbal distinctions was observed already by Leisi (1953). The effect of verbal arguments was investigated first by Verkuyl (1972) in his work on aspectual composition, who dealt with features like [+SPECIFIED QUANTITY] that are projected from the argument to the verb phrase. Another approach relying on feature projection is Platzack 1979. Dowty (1979) criticized these feature-based approaches, as they merely describe the facts and do not really explain them. Dowty himself, as well as Hoepelman (1976) and Hoepelman and Rohrer (1980), developed theories in the paradigm of model-theoretic semantics to capture the facts in a more explanatory way. See Krifka 1986 for a detailed criticism of their approaches. It seems to me that the general insight of the feature-based approach, that the arguments and the complex expression have something in common, is lost in these model-theoretic approaches. The theory presented here and in Krifka 1986, 1989 is more in the spirit of ter Meulen 1984 and Bach 1986, who tried to characterize the similarities of noun denotations and verb denotations by model-theoretic means, but they remain at a rather informal level. There is one explicit model-theoretic approach which looks similar to the one developed here, namely Hinrichs 1985. But Hinrichs’ theory crucially depends on the notion of a stage of an individual, which complicates his formalizations and has some unintuitive side effects. The theory presented here comes most closely to Dowty 1987, 1989, and Link 1987.

2 The Semantic Representation Language and Its Interpretation

In this section, I will introduce the semantic representation language and the basic facts about the model structure of its interpretations. I assume a type-theoretic language with function symbols and identity. For reasons of simplicity, it is assumed to be extensional.

To handle the semantics of cumulative and quantized reference, we must provide for the semantic operation of joining two individuals to a new individual. This means that our model structure must be of the form of a *lattice* (cf. Link 1983). Here, I can simplify Link’s approach to aspects

fer in their syntactic distribution and in their semantic type; the first can serve as an NP, whereas the second cannot. One should contrast instead expressions like *wine* and *an apple*, or *apples* and *five apples*, or *wine* and *a glass of wine*. The first element in each of those pairs has the property of referring cumulatively (cf. Quine 1960): whenever there are two entities to which *wine* applies, this predicate applies to their collection as well. The second member in each pair does not have this property: whenever there are two (different) entities to which *an apple* applies, this predicate does not apply to their collection. Let us subsume these properties under the heading of *nominal reference*. Predicates like *wine* will be called *cumulative*, and predicates like *five apples* will be called *quantized*. As for “aspectual classes” or “aktionsarten,” I would like to use another name for this concept, because these terms were originally coined for related, but quite different phenomena in the morphology of the Slavic and Germanic languages. I will call the notion we are after *temporal constitution*, which was invented as the German term “Zeitkonstitution” by François (1985) and covers a concept which was treated perhaps most prominently by Vendler (1957). I will concentrate here on what Vendler calls *activities* and *accomplishments*, which I call *atelic* and *telic* expressions, following Garey (1957). To give a preliminary definition: A verbal expression is atelic if its denotation has no set terminal point (e.g., *run*), and it is telic if it includes a terminal point (e.g., *run a mile*). This well-known semantic distinction is supported by a battery of tests (cf. Dowty 1979). For example, in ordinary, e.g., non-iterative interpretations, atelic expressions allow for durative adverbials like *for an hour*, but do not allow for time-span adverbials like *in an hour*, whereas with telic expressions the situation is reversed.

- (1) a. John ran (for an hour)/(**in an hour*).
 b. John ran a mile (**for an hour*)/(in an hour).

That nominal reference and temporal constitution are related became clear in two ways. First, the two concepts are felt to be semantically similar. For example, a quantized NP like *an apple* denotes an object with precise limits, just as *run a mile* denotes an event with precise limits. On the other hand, a cumulative NP like *wine* denotes something without clear limitation, just like what *run* denotes also has no clear limitation. Second, it was observed that the reference types of verbal arguments often determine the temporal constitution of complex verbal expressions, insofar as a quantized argument yields a telic verbal predicate, and a cumulative argument yields an atelic verbal predicate:

- (2) a. John drank wine (for an hour)/(**in an hour*).
 b. John drank a glass of wine (**for an hour*)/(in an hour).

However, we cannot observe this effect with any verbal predicate, as the following examples show:

- (T1) $\forall P[SNG(P) \rightarrow QUA(P)]$
 (T2) $\forall P[SNG(P) \rightarrow CUM(P)]$
 (T3) $\forall P[QUA(P) \rightarrow \neg SCUM(P)]$
 (T4) $\forall P[QUA(P) \rightarrow ATM(P)]$

We have to postulate some structure for events and times. First, we assume that the time lattice is atomic, that is, $ATM(\mathcal{T})$, with \mathcal{T}_a as the set of atoms (*time points*). (I leave the question open as to whether objects and events are atomic as well). Second, we assume a *temporal order* relation \leq , which is a linear order for time points. With these notions, we can define convex times, or *time intervals*. (In the following, I will use t, t' , etc., as variables for times, and e, e' , etc., as variables for events.)

- (P18) $ATM(\mathcal{T}) \wedge \forall t[\mathcal{T}_a(t) \leftrightarrow ATOM(t, \mathcal{T})]$
 (\mathcal{T}_a is the predicate of time points)
 (P19) $\forall t, t', t''[\mathcal{T}_a(t) \wedge \mathcal{T}_a(t') \wedge \mathcal{T}_a(t'') \rightarrow [t \leq t \wedge [t \leq t' \wedge t' \leq t'' \rightarrow t \leq t''] \wedge [t \leq t' \vee t' \leq t] \wedge [t \leq t' \wedge t' \leq t \rightarrow t = t'']]$
 (\leq is a linear order for time points)
 (P20) $\forall t, t'[t \leq t' \leftrightarrow \forall t'', t''''[t'' \sqsubseteq t \wedge t'''' \sqsubseteq t' \rightarrow t'' \leq t''']]$
 (extension of \leq to times in general)
 (P21) $\forall t[CONV(t) \leftrightarrow \forall t', t'', t''''[t' \sqsubseteq t \wedge t'' \sqsubseteq t \wedge t' \leq t'' \leq t'''' \rightarrow t'''' \sqsubseteq t]]$
 (convex times, or intervals)

Third, we assume a function τ from the extension of \mathcal{E} to the extension of \mathcal{T} , the *temporal trace* function; this function maps an event to its “run time,” or temporal trace. It is a homomorphism relative to the join operation:

- (P22) $\forall e, e'[\tau(e) \sqcup \tau(e') = \tau(e \sqcup e')]$

That is, the join of the temporal traces of two events equals the temporal trace of the join of these events.

3 Cumulativity and Quantization for Object and Event Predicates

In this section, we will apply the notions we have developed so far to the semantic description of certain predicate types. First, we will look at predicates on objects, and then at predicates on events.

Characterizing object predicates like *wine* versus *a glass of wine*, or *apples* versus *five apples*, is straightforward. If we represent these expressions by predicates in the semantic representation languages, we have:

- (4) a. $wine \sqsubseteq \mathcal{O} \wedge CUM(wine)$
 b. $a.glass.of.wine \sqsubseteq \mathcal{O} \wedge QUA(a.glass.of.wine)$
 c. $apples \sqsubseteq \mathcal{O} \wedge CUM(apples)$
 d. $five.apples \sqsubseteq \mathcal{O} \wedge QUA(five.apples)$

(4a) says that *wine* is a predicate on objects (note that we make no distinction between stuff and objects for reasons of simplicity), and that it is

relevant to my argument; for example, I will not distinguish between individual entities and quantities of matter. But I will extend Link’s approach to cover event predicates as well.

Assume that we have two non-overlapping sorts of entities, *objects* (characterized by a predicate \mathcal{O}), *events* (characterized by a predicate \mathcal{E}), and *times* (characterized by a predicate \mathcal{T}). The extensions of \mathcal{O} , \mathcal{E} and \mathcal{T} have the structure of a complete join semi-lattice without a bottom element. Let \sqcup be a two-place operation (join), and $\sqsubseteq, \sqsubset, \circ$ two-place relations (part, proper part, overlap). Then the following postulates must hold for admissible interpretations of the semantic representation language:

- (P1) $\forall x, y, z[(x \sqcup y = z) \rightarrow [\mathcal{O}(x) \wedge \mathcal{O}(y) \wedge \mathcal{O}(z)] \vee [\mathcal{E}(x) \wedge \mathcal{E}(y) \wedge \mathcal{E}(z)] \vee [\mathcal{T}(x) \wedge \mathcal{T}(y) \wedge \mathcal{T}(z)]]$ (restriction to $\mathcal{O}, \mathcal{E}, \mathcal{T}$)
 (P2) $\forall x, y \exists z[x \sqcup y = z]$ (completeness)
 (P3) $\forall x, y[x \sqcup y = y \sqcup x]$ (commutativity)
 (P4) $\forall x[x \sqcup x = x]$ (idempotency)
 (P5) $\forall x, y, z[x \sqcup [y \sqcup z] = [x \sqcup y] \sqcup z]$ (associativity)
 (P6) $\forall x, y[x \sqsubseteq y \leftrightarrow x \sqcup y = y]$ (part)
 (P7) $\neg \exists x \forall y[x \sqsubseteq y]$ (no \perp element)
 (P8) $\forall x, y[x \sqsubset y \leftrightarrow x \sqsubseteq y \wedge \neg x = y]$ (proper part)
 (P9) $\forall x, y[x \circ y \leftrightarrow \exists z[z \sqsubseteq x \wedge z \sqsubseteq y]]$ (overlap)

We can generalize the join operation to the fusion operation, which maps a set P to its lowest upper bound:

- (P10) $\forall x, P[[P \sqsubseteq \mathcal{O} \vee P \sqsubseteq \mathcal{E} \vee P \sqsubseteq \mathcal{T}] \rightarrow FU(P) = x]$
 $\leftrightarrow \forall y[P(y) \rightarrow y \sqsubseteq x] \wedge \forall z[\forall y[P(y) \rightarrow y \sqsubseteq z] \rightarrow x \sqsubseteq z]$ (fusion)

We now define some higher-order predicates and relations to characterize different reference types.

- (P11) $\forall P[CUM(P) \leftrightarrow \forall x, y[P(x) \wedge P(y) \rightarrow P(x \sqcup y)]]$
 (cumulative reference)
 (P12) $\forall P[SNG(P) \leftrightarrow \exists x[P(x) \wedge \forall y[P(y) \rightarrow x = y]]]$ (singular reference)
 (P13) $\forall P[SCUM(P) \leftrightarrow CUM(P) \wedge \neg SNG(P)]$
 (strictly cumulative reference)
 (P14) $\forall P[QUA(P) \leftrightarrow \forall x, y[P(x) \wedge P(y) \rightarrow \neg y \sqsubset x]]$ (quantized reference)
 (P15) $\forall P[SQUA(P) \leftrightarrow QUA(P) \wedge \forall x[P(x) \rightarrow \exists y[y \sqsubset x]]]$
 (strictly quantized reference)
 (P16) $\forall x, P[ATOM(x, P) \leftrightarrow P(x) \wedge \neg \exists y[y \sqsubset x \wedge P(y)]]$ (x is a P -atom)
 (P17) $\forall P[ATM(P) \rightarrow \forall x[P(x) \rightarrow \exists y[y \sqsubseteq x \wedge ATOM(y, P)]]]$
 (P has atomic reference)

Postulate (P17) says that if P is atomic, then every x which is P contains a P -atom. The following theorems hold, as can be easily checked:

terminal point (both events might be even identical). The difference is that an event of running might be a part of another event of running which has a later terminal point, whereas this is not possible for an event of running a mile.

We can define the notion of a telic event predicate like follows. First, let us define a function TP which maps events to the last time point in their run time. Then we can define the notion of event predicates which have a set terminal point, STP .

$$(P23) \quad \forall e, t [TP(e) = t \leftrightarrow \mathcal{I}_a(t) \wedge t \sqsubseteq \tau(e) \wedge \forall t' [t' \sqsubseteq \tau(e) \rightarrow t' \leq t]]$$

(the terminal point of an event)

$$(P24) \quad \forall P [STP(P) \leftrightarrow \forall e [P(e) \rightarrow \forall e' [P(e') \wedge e' \sqsubseteq e \rightarrow TP(e) = TP(e')]]]$$

(event predicates with set terminal point)

An STP event predicate, then, applies to events such that all subevents which fall under the predicate have the same terminal point. In a natural interpretation of *run* and *run.a.mile*, we can assume the following properties:

- (7) a. $run \subseteq \mathcal{E} \wedge \neg STP(run)$
 b. $run.a.mile \subseteq \mathcal{E} \wedge STP(run.a.mile)$

That is, *run.a.mile* is a predicate with a set terminal point, as every subevent of an event of running a mile has the same terminal point. This is different for *run*. In general, we may characterize telic predicates P as $STP(P)$, and atelic predicates P as $\neg STP(P)$.

If we defined a mapping from objects to spatial regions and define the notion of a border of regions, and hence, of objects, then we could characterize nominal predicates like *a.glass.of.wine* and *wine* similarly, as implying a set border or as not implying a set border. In this way, we could capture the similarity between expressions like ‘run’ and ‘run a mile’ with ‘wine’ and ‘a glass of wine’, respectively.

It turns out, however, that a good deal of the similarity can already be covered by the notions of cumulative and quantized predicates. The reason is that there is a relation between predicates with a set terminal point and an interesting class of cumulative event predicates. This class can be defined as follows: With the exception of singular event predicates (that refer to one event only), event predicates in natural language typically have the property that they apply to events which have different terminal points. For example, a predicate like *run*, or *run a mile*, refers to events that end at different times. Let us define the notion of *natural event predicates*, NEP , as an event predicates with that property:

$$(P25) \quad \forall P [NEP(P) \leftrightarrow P \subseteq \mathcal{E} \wedge \exists e, e' [P(e) \wedge P(e') \wedge \neg TP(e) = TP(e')]]$$

Now we can prove that cumulative natural event predicates cannot have a set terminal point:

cumulative. (4b) says that *a.glass.of.wine* is also a predicate on objects, but that this predicate is quantized. Similarly, *apples* is a cumulative object predicate, and *five.apples* is a quantized object predicate. I will not go into the semantic composition of predicates which are syntactically or morphologically complex, like *a.glass.of.wine*, *apples*, or *five.apples*; see Krifka 1986, 1989 for a treatment.

Now look at expressions like *run* and *run a mile*. In the standard treatment (5i), one-place verbal predicates are reconstructed as applying to objects, just as object predicates. For example, *run* is analyzed as applying to every object that runs. However, there are good reasons to assume that these predicates have also an argument place for events (cf. Davidson 1967), as in (5ii), or even that they are predicates on events, and that the participants are related to these events by thematic relations like Agent, Theme, etc. (cf. Parsons 1980, Carlson 1984, Bäuerle 1988), as in (5iii):

- (5) *Mary runs.*
- i. $run(Mary)$
 - ii. $run(Mary, e)$
 - iii. $run(e) \wedge AG(e, Mary)$

Obviously, if we want to model the temporal constitution of verbal expressions, we should choose either (5ii) or (5iii) as a representation format, because the temporal constitution can most easily be formulated with the help of the event argument e . Furthermore, it will turn out that the rules can be more easily formulated in the format (5iii), which factorizes a verbal predicate into an event property and the thematic information. So I will base what follows on this representation format.

How can we characterize an atelic event predicate like *run* and a telic event predicate like *run.a.mile* within our theoretical framework? We may say that the first is cumulative and the second is quantized: If we have two events of running, then they form together an event of running; and if we have an event of running a mile, then no proper part of it is an event of running a mile. So we can reconstruct atelic and telic expressions by cumulative and quantized event predicates, respectively:

- (6) a. $run \subseteq \mathcal{E} \wedge CUM(run)$
 b. $run.a.mile \subseteq \mathcal{E} \wedge QUA(run.a.mile)$

We might ask how this characterization of telic and atelic predicates relates to the traditional one, that telic predicates have a set terminal point and atelic predicates lack such a set terminal point. There is, in fact, a close relationship:

The notion of a “set terminal point” cannot be defined for bare events or “event tokens”, but only for events with respect to a certain description, event predicates, or “event types.” For consider a concrete event of running and a concrete event of running a mile; then surely both events have a

that the theta role is specified in the preposition; the NP governed by the preposition only has a dummy theta feature “empty” that is not realized in the interpretation of the determiner.

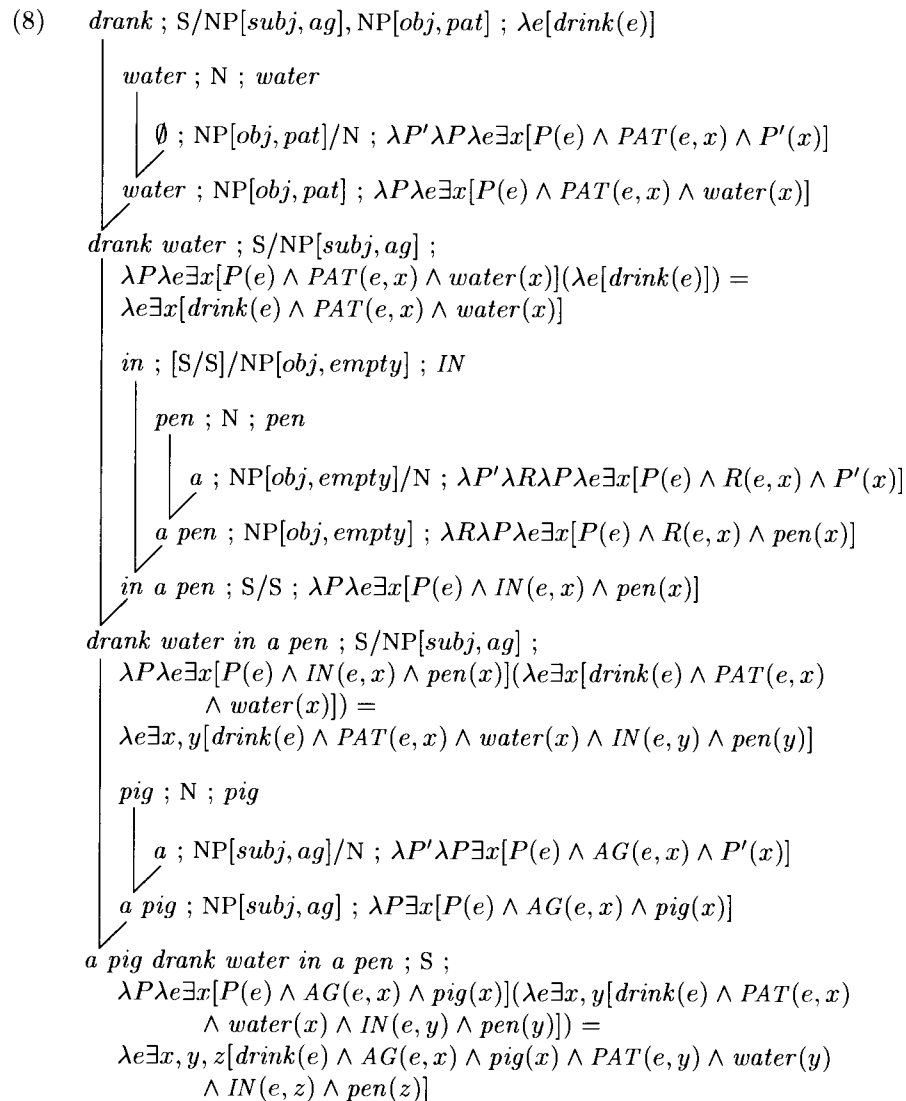

After all free variables are bound, we obtain a predicate on events without free variables, the *sentence radical* (S). This can be transformed to a sentence (S') by the application of a *sentence mood operator*, e.g., the declarative operator, which simply binds the event variable with an existential quantifier.

(T5) $\forall P[CUM(P) \wedge NEP(P) \rightarrow \neg STP(P)]$

Proof: Assume an event predicate P with $CUM(P)$ and $NEP(P)$. As P is natural, there are two events e_1, e_2 such that $P(e_1), P(e_2)$, and $\neg TP(e_1) = TP(e_2)$. Assume that $TP(e_1) \leq TP(e_2)$. As P is cumulative, it holds that $P(e_1 \sqcup e_2)$. As $\tau(e_1 \sqcup e_2) = \tau(e_1) \sqcup \tau(e_2)$, we have $\neg TP(e_1) = TP(e_1 \sqcup e_2)$. But it holds that $e_1 \sqsubseteq e_1 \sqcup e_2$. Consequently, we have $\neg STP(P)$.

This means that, under the assumption that P is cumulative, $CUM(P)$, and not singular, $\neg SNG(P)$, we can normally assume that P has no set terminal point, $\neg STP(P)$. That is, strictly cumulative event predicates can safely be taken as atelic under the traditional definition (lacking a set terminal point).

On the other hand, whenever we have a quantized event predicate P , $QUA(P)$, this will have a set terminal point, $STP(P)$. This is because when $QUA(P)$ and $P(e)$, then e has no proper part; so all parts e' of e will have the same end point, as e' and e are in fact identical. Therefore all quantized event predicates will be telic, under the traditional definition. But note that there are predicates with set terminal points that fail to be quantized. One example is ‘walk to the station’: If this predicate applies to an event e , then it will also apply to the latter half of e ; so it is not quantized.

In the following, I will view telic predicates simply as quantized event predicates, and atelic predicates as strictly cumulative event predicates.

4 A Framework for Object and Event Reference

Before we turn to a formal description of the influence of nominal arguments to verbal predicates, I will sketch the syntactic and semantic framework I am assuming by way of an example (see Krifka 1986 for a more explicit treatment).

I assume a categorial-like syntactic representation; this is, however, not essential. Verb argument places come with features such as category (like NP), case (like *subj, obj*), and theta-roles (like *ag, pat*). The expressions that fill these arguments must have the same values for these features. The value of the theta feature is interpreted semantically by corresponding thematic relations. In the derivation tree in (8), I specify the expression, its syntactic category, and its semantic interpretation. The general syntactic operation is concatenation, and the semantic operation is functional application.

A verb is interpreted as a one-place predicate of events; the syntactic argument slots have no counterpart in its semantic representation, but only in its syntactic categorization. The theta-role information, which is specified with the argument slots in syntax, is passed to the subcategorized NPs, where it is realized as a part of the semantic representation of the determiners (e.g., *pat* is realized as $PAT(e, x)$). With free adjuncts like *in a pen*, the thematic relations are specified within the adjunct. Here I assume

descriptions of w and, consequently, e . First, let w be described as *wine*, and hence e as *drink wine*. As *wine* is cumulative, it is normally the case that it can also be applied to proper parts of w , like w' . But then it should be possible to apply the predicate *drink wine* to the corresponding proper part of e , namely e' , as well. Secondly, let w be described as *a glass of wine*, and e consequently as *drink a glass of wine*. As *a glass of wine* is quantized, no proper part of w can be described as *a glass of wine*. But then no proper part of e can be described as *drink a glass of wine* either.

Technically speaking, we have to assume a *homomorphism* from objects to events which preserves the lattice structure. This should follow from the properties of the thematic relation that mediates between event and object. To characterize these properties, I assume the following notions:

$$(P26) \quad \forall R[\text{SUM}(R) \leftrightarrow \forall e, e', x, x'[R(e, x) \wedge R(e', x') \rightarrow R(e \sqcup e', x \sqcup x')]]$$

(summativity)

$$(P27) \quad \forall R[\text{UNI-O}(R) \leftrightarrow \forall e, x, x'[R(e, x) \wedge R(e, x') \rightarrow x = x']]$$

(uniqueness of objects)

$$(P28) \quad \forall R[\text{UNI-E}(R) \leftrightarrow \forall e, e', x[R(e, x) \wedge R(e', x) \rightarrow e = e']]$$

(uniqueness of events)

$$(P29) \quad \forall R[\text{MAP-O}(R) \leftrightarrow \forall e, e', x[R(e, x) \wedge e' \sqsubseteq e \rightarrow \exists x'[x' \sqsubseteq x \wedge R(e', x')]]]$$

(mapping to objects)

$$(P30) \quad \forall R[\text{MAP-E}(R) \leftrightarrow \forall e, x, x'[R(e, x) \wedge x' \sqsubseteq x \rightarrow \exists e'[e' \sqsubseteq e \wedge R(e', x')]]]$$

(mapping to events)

Summativity (that is, cumulativity for two-place relations) provides the basic connection between thematic relations and the join operation \sqcup . For example, two (distinct) events of drinking a glass of wine yield an event of drinking two glasses of wine. *Uniqueness of objects* captures the fact that an event is related to a specific object, for example, a drinking of a glass of wine is related via the patient role to this glass of wine, and to nothing else. *Uniqueness of events* says that there is only one event related to the object by the thematic relation; for example, for a specific glass of wine there can be only one drinking event. *Mapping to objects* can be exemplified by our example as follows: every part of a drinking of a glass of wine corresponds to a part of the glass of wine. And *mapping to events* says in the example at hand that every part of the glass of wine being drunk corresponds to a part of the drinking event. These are just informal characterizations of the properties of thematic relations; they will be discussed in more detail below.

The following postulate covers the notion of *iterativity*. It is a relation between an event e , an object x and a thematic relation R saying that at least one part of x is subjected to at least two different parts of e . This notion applies to, e.g., the reading of a book if at least one part of the book is read twice. It is more permissive than the usual notion of iterativity,

$$(9) \quad \begin{array}{l} \dots \\ \downarrow \\ \cdot ; S'/S ; \lambda P \exists e P(e) \\ A \text{ pig drank water in a pen. ; } S' ; \\ \exists e \exists x, y, z [\text{drink}(e) \wedge \text{AG}(e, x) \wedge \text{pig}(x) \wedge \text{PAT}(e, y) \wedge \text{water}(y) \\ \wedge \text{IN}(e, z) \wedge \text{pen}(z)] \end{array}$$

This representation of declarative sentences thus conforms to the truth scheme of Austin (1961), who assumed that a declarative sentence consists of two basic semantic constituents, namely a specification of an event type and a reference to a specific event, which is claimed to be of the specified type. Types of events I capture by event predicates, and the reference to a specific event by the existential quantifier. Surely, both reconstructions will turn out to be too simple, but they suffice for the present purpose, and the analysis to be developed hopefully can be recast in more complex representations.

5 The Impact of Arguments

In this section, which repeats part of Krifka 1989, I will show how the impact of the nominal reference of arguments on the temporal constitution of verbal predicates can be captured formally.

The basic idea is that, with certain thematic relations, the reference properties of the syntactic arguments carry over to the reference properties of the complex construction. There is a way to visualize this transfer of reference types, namely space-time diagrams. In these diagrams, space is represented by one axis, and time by the other. Objects, with their spatial extension, can be represented as lines, and events can be mapped to the time axis. Now consider e , the event of drinking a quantity of wine w (which is gradually disappearing during the drinking):

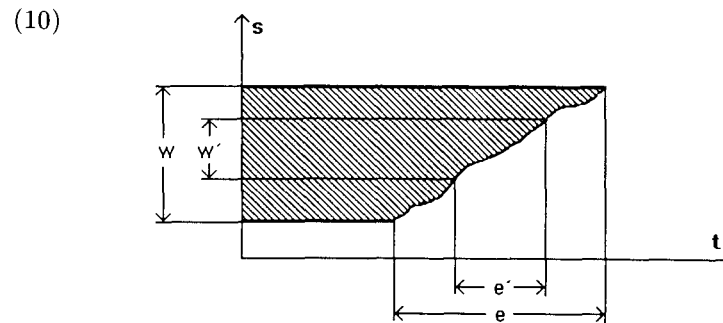

By this picture the intuitive notion that the object is subjected to the event in a gradual manner should become clear. Consider two possible

$$(T7) \quad \forall P, R, e, x [SNG(P) \wedge SUM(R) \wedge SCUM(\lambda e \exists x [P(x) \wedge R(e, x)]) \rightarrow \\ ITER(e, x, R)]$$

If we exclude the iterative interpretation and retain singular reference of δ and summativity of θ , then it follows that ϕ cannot be strictly cumulative:

$$(T8) \quad \forall P, R, e, x [SNG(P) \wedge SUM(R) \wedge \neg ITER(e, x, R) \rightarrow \\ \neg SCUM(\lambda e \exists x [P(x) \wedge R(e, x)])]$$

Hence a verbal predicate like *read the letter*, under a non-iterative and non-partitive interpretation, cannot be strictly cumulative, and hence cannot be atelic.

Sometimes the iterative interpretation is excluded in the first place, namely with *effected* or *consumed* objects, as in *write the letter* or *drink the wine*. The reason is that an object can be subjected to an event of drinking or writing a maximum of one time in its career. Therefore, uniqueness of events should be postulated for the respective thematic relations. And this excludes an iterative interpretation. Proof: Assume to the contrary that θ is unique for events, $\theta(e_0, x_0)$ and $ITER(e_0, x_0, \theta)$. Because of iterativity, it follows that there are e_1, e_2, x_1 with $e_1 \sqsubseteq e_0, e_2 \sqsubseteq e_0, \neg e_1 = e_2$ and $x_1 \sqsubseteq x_0$ for which it holds that $\theta(e_1, x_1)$ and $\theta(e_2, x_1)$. But this contradicts uniqueness of events.

$$(T9) \quad \forall R, e, x [R(e, x) \wedge UNI-E(R) \rightarrow \neg ITER(e, x, R)]$$

Let us now investigate the influence of quantized nominal predicates like *a letter*. Under which conditions can we assume that they cause the complex verbal predicate to be quantized as well? One set of conditions is that the thematic role θ must satisfy uniqueness of objects and mapping to objects, and that iterative interpretations are excluded. Proof: We assume to the contrary that δ is quantized, $\phi(e_1), \phi(e_2)$ and $e_2 \sqsubset e_1$. Then there are x_1, x_2 with $\delta(x_1), \theta(e_1, x_1)$ and $\delta(x_2), \theta(e_2, x_2)$, according to the definition of ϕ . Because $e_2 \sqsubset e_1$ and θ satisfies mapping to objects, there is an x_3 such that $x_3 \sqsubseteq x_1$ and $\theta(e_2, x_3)$. Because uniqueness of objects, it holds that $x_3 = x_2$, and therefore $x_2 \sqsubseteq x_1$. As we have $\theta(e_2, x_2), e_2 \sqsubset e_1$ and $\neg ITER(e_1, x_1, \theta)$, we can infer that $\neg x_1 = x_2$. With $x_2 \sqsubseteq x_1$, this yields $x_2 \sqsubset x_1$, but this contradicts the assumption that δ is quantized. Hence there are no e_1, e_2 as assumed above, and that means that ϕ is quantized.

$$(T10) \quad \forall P, R, e, x [QUA(P) \wedge UNI-O(R) \wedge MAP-O(R) \wedge \neg ITER(e, x, R) \\ \rightarrow QUA(\lambda e \exists x [P(x) \wedge R(e, x)])]$$

As a special case of (T10), we have the following theorem for thematic relations which satisfy uniqueness of events (e.g., effected and consumed objects), as this property excludes an iterative interpretation in the first place:

$$(T11) \quad \forall P, R [QUA(P) \wedge UNI-O(R) \wedge MAP-O(R) \wedge UNI-E(\theta) \rightarrow \\ QUA(\lambda e \exists x [P(x) \wedge R(e, x)])]$$

Even in the iterative case it holds that examples like ‘read a letter’ are atomic. The conditions for thematic relations which are relevant for this

which would claim in the example at hand that the whole book must have been read at least twice.

$$(P31) \quad \forall e, x, R [ITER(e, x, R) \leftrightarrow R(e, x) \wedge \exists e', e'', x' [e' \sqsubseteq e \wedge e'' \sqsubseteq e \\ \wedge \neg e' = e'' \wedge x' \sqsubseteq x \wedge R(e', x') \wedge R(e'', x')]] \quad (\text{iterativity})$$

Which properties must we assume for thematic relations to derive their homomorphism properties? Let us translate an expression like *read a letter* by predicates ϕ ,

$$(11) \quad \phi = \lambda e \exists x [\alpha(e) \wedge \delta(x) \wedge \theta(e, x)]$$

where α represents the verbal predicate (*read*), δ represents the nominal predicate (*a letter*), and θ represents a thematic relation (here, a specific patient relation). In the following, I will examine the effects of some properties of δ and θ on ϕ . The verbal predicate α will be considered to be cumulative throughout.

We start with the question: What are the conditions for ϕ to be cumulative? One set of conditions is: ϕ is cumulative if δ is cumulative and θ is summative (an example is *read letters*). Proof: Assume e_1, e_2 (not necessarily distinct) with $\phi(e_1), \phi(e_2)$. According to the definition of ϕ , there are two objects x_1, x_2 with $\alpha(e_1), \delta(x_1), \theta(e_1, x_1)$ and $\alpha(e_2), \delta(x_2), \theta(e_2, x_2)$. Because α and δ are cumulative, it holds that $\alpha(e_1 \sqcup e_2)$ and $\delta(x_1 \sqcup x_2)$, and because θ is summative, it holds that $\theta(e_1 \sqcup e_2, x_1 \sqcup x_2)$. Hence $\phi(e_1 \sqcup e_2)$, that is, ϕ is cumulative:

$$(T6) \quad \forall P, Q, R [CUM(P) \wedge CUM(Q) \wedge SUM(R) \rightarrow CUM(\lambda e \exists x [P(e) \wedge \\ Q(x) \wedge R(e, x)])]$$

As singular predicates (e.g., *the letter*) are cumulative as well, albeit in a somewhat pathological way, this result holds for them, too. Consider the following example, with *the letter* as a predicate with singular reference applying to the letter.

$$(12) \quad \text{read the letter} \\ \lambda e \exists x [\text{read}(e) \wedge \text{PAT}(e, x) \wedge \text{the.letter}(x)]$$

But if we want to understand *read the letter* as atelic, as in *he read the letter for an hour*, then we clearly have to assume either a partitive reading or an iterative reading. Partitive readings will be treated in Section 7. As for the iterative reading, it can be shown that if ϕ is strictly cumulative, θ is summative, and δ has singular reference, then we get an iterative interpretation.

Proof: If ϕ is strictly cumulative, then we have two distinct e_1, e_2 with $\phi(e_1), \phi(e_2)$. According to the definition of ϕ , there are two objects x_1, x_2 with $\delta(x_1), \theta(e_1, x_1)$ and $\delta(x_2), \theta(e_2, x_2)$. Because θ is summative, it holds that $\theta(e_1 \sqcup e_2, x_1 \sqcup x_2)$, and because δ has singular reference, it holds that $x_1 = x_2$. With $\theta(e_1 \sqcup e_2, x_1), \theta(e_1, x_1), \theta(e_2, x_1)$ and $\neg e_1 = e_2$, the conditions for iterativity (P31) are met, as x_1 is subjected to two different parts of the event $e_1 \sqcup e_2$, namely e_1 and e_2 . So the following theorem holds:

I think the conditions of summativity, graduality and uniqueness of events are intuitively plausible for the respective patient relations. In the next section, I will discuss the transfer properties for thematic relations in greater detail.

6 Some Consequences for the Theory of Thematic Relations

In this section, we will discuss some consequences which follow from the assumption of properties of thematic relations, as discussed in the last section.

The most general property is *summativity*, which obtains for all patient relations, and probably for all thematic relations whatsoever. This means that thematic relations are not sensitive to the “size” of the entities they relate to each other.

One thing which summativity can buy us is a simpler and intuitively more appealing treatment of *cumulative readings* than the one offered in Scha 1981. For example, if there are two events, one to be described with (14a), the other with (14b),

- (14) a. John saw three zebras.
b. Mary saw four zebras.

and if the zebras John and Mary saw do not overlap, then the sentence *John and Mary saw seven zebras* can be derived if one assumes summativity for the experiencer relation and the stimulus relation, and that the count noun relation contains extensive measure functions compatible with the object lattice, a notion introduced in Krifka 1986, 1989. *EXP* and *STI* should represent the experiencer and stimulus relation, and *zebra*(x, n) says that x and n are zebras.

$$(15) \frac{\begin{array}{l} see(e_1) \wedge EXP(e_1, John) \wedge STI(e_1, x_1) \wedge zebra(x_1, 3) \\ see(e_2) \wedge EXP(e_2, Mary) \wedge STI(e_2, x_2) \wedge zebra(x_2, 4) \\ \neg x_1 \circ x_2 \end{array}}{see(e_1 \sqcup e_2) \wedge EXP(e_1 \sqcup e_2, John \sqcup Mary) \wedge STI(e_1 \sqcup e_2, x_1 \sqcup x_2) \wedge zebra(x_1 \sqcup x_2, 7)}$$

Note that the derived sentence has rather weak truth conditions, as it remains unspecified how the zebras relate to John and Mary individually. This is as it should be, as the different possibilities are not different “readings” of the sentence. In contrast to other theories of cumulative predication, for example the one by Gillon (1987), this is a natural outcome of a very simple rule and need not be stated by a complicated rule involving quantification over partitions of sets and the like.

An objection against this treatment might be that a sentence like *John and Mary saw seven zebras* are understood as saying that they saw exactly seven zebras, a reading which is not captured by $\exists e, x[see(e) \wedge EXP(e, John \sqcup Mary) \wedge STI(e, x) \wedge zebra(x, 7)]$, as this representation allows for John and

result are that they satisfy uniqueness of objects and mapping to events. We have to assume δ not only to be quantized, but to be strictly quantized, which is not a substantial limitation. Proof: Assume an e_1 with $\phi(e_1)$, hence an x_1 with $\delta(x_1)$ and $\theta(e_1, x_1)$. Because δ is strictly quantized, x_1 contains a proper part x_2 , that is, $x_2 \sqsubset x_1$, with $\neg\delta(x_2)$. Because of mapping to events, there is an e_2 with $e_2 \sqsubseteq e_1$ and $\theta(e_2, x_2)$. Because of uniqueness of objects, x_2 is the only object with this property. Hence there is no x with $\delta(x)$ and $\theta(e_2, x)$. But then $\neg\phi(e_2)$ holds, and this means that e_1 contains a ϕ -atom, e_2 . As we made no special assumption for e_1 , it follows that ϕ is atomic.

$$(T12) \forall P, R[SQUA(P) \wedge MAP-E(R) \wedge UNI-O(R) \rightarrow ATM(\lambda e \exists x[P(x) \wedge R(e, x)])]$$

In Krifka 1986, 1989, I have shown how we can explain with the help of these results why durative adverbials like *for an hour* select for atelic verbal predicates, whereas time-span adverbials like *in an hour* select for telic predicates. The underlying reason is that durative adverbials presuppose that the verbal predicate they are applied to is strictly cumulative, and time-span adverbials presuppose that the verbal predicate they are applied to is atomic. Now, quantized verbal predicates (\approx telic predicates) are atomic and not strictly cumulative; hence their distribution with respect to those adverbials is explained. Strictly cumulative verbal predicates (\approx atelic predicates) can be combined with durative adverbials, and they can also be combined with time-span adverbials under the presupposition that they are atomic. Normally, this presupposition is not warranted, and hence the combination with time-span adverbials sounds odd.

To conclude this section, let us use the properties of thematic relations to classify the patient relations of different verbs. It is useful to introduce a new notion that says that the object is subjected to the event in a gradual manner, as visualized by the space-time diagram (10). I call this *graduality*; it comprises uniqueness of objects, mapping to objects, and mapping to events.

$$(P32) \forall P[GRAD(P) \leftrightarrow UNI-O(P) \wedge MAP-O(P) \wedge MAP-E(P)] \text{ (graduality)}$$

The criteria for the classification of thematic roles can be applied to transitive verbs. This yields at least three interesting classes; two classes can be further subdivided for independent reasons.

(13) example	summa- tivity	gradu- ality	uniqu. events	label
write a letter	×	×	×	gradual effected patient
eat an apple	×	×	×	gradual consumed patient
read a letter	×	×	–	gradual patient
touch a cat	×	–	–	affected patient
see a horse	×	–	–	stimulus

(16) John saw seven zebras in an hour.

Time-span adverbials like *in an hour* select for atomic verbal predicates (cf. Krifka 1986, 1989). The simplest way to get an atomic reading of *see seven zebras* is that in the relevant event, the zebras were seen in some temporal succession.

The fact that the object roles of verbs like *see* sometimes have the same mapping properties as the object roles of verbs like *eat* indicates that the properties we have discussed so far are not “hard-wired” in the thematic relations, but follow from other knowledge sources. Consequently, we should assume that even the object role of verbs like *eat* does not exhibit graduality as some grammatical feature, but simply because the normal way of eating enforces the graduality properties.

However, there are some problems with the mapping properties. With mapping to events, it is often the case that only a certain class of parts of the object are relevant. As an example, consider *eat the apple* and *peel the apple*; in the first case, all the parts of the apple are involved, whereas in the second case, only the surface parts are. Another example is *read the book* and *burn the book*; surely, there are parts of the book which are relevant in the second case (e.g., the cover of the book) which do not count as parts of the book in the first case. To handle these phenomena, we may assume that the verb selects specific *aspects* of an object (e.g., only its surface).

Perhaps more problematic is mapping to objects. As an example, consider *build the house*. There are surely parts of the event of building a house which cannot be mapped to parts of the house. An example is the erection of the scaffold, which is clearly part of building the house, but the scaffold is not a part of the house, and even vanishes when the house is finished. Therefore, mapping to objects does not hold in a strict sense for complex events.

This problem can be solved if we assume that predicates like *build the house* refer to events consisting of events which themselves fall under different quantized predicates. A list of such predicates may be called a *scenario*, after Link 1987. For example, the building of a house consists in raising a loan, buying a place, and so on. This can be captured by a predicate $\phi = \lambda e \exists e_1 \dots e_n [\phi_1(e_1) \wedge \dots \wedge \phi_n(e_n) \wedge e = e_1 \sqcup \dots \sqcup e_n]$, where all the ϕ_i are quantized and disjoint from each other. It can be shown that ϕ is then quantized as well. Proof: Assume to the contrary that $\phi(e_1)$, $\phi(e_2)$ and $e_1 \sqsubset e_2$; then there is at least one ϕ_i , $1 \leq i \leq n$, and e_3, e_4 such that $\phi_i(e_3)$, $\phi_i(e_4)$ and $e_3 \sqsubset e_4$, which contradicts the assumption that ϕ_i is quantized.

However, an objection to this solution may be raised, as many events lack a standard scenario (cf. Link 1987). For example, with the building of a house, there need not be an erection of a scaffold. Therefore, we have to assume that a complex event of a certain type has to be related to *some*

Mary to have seen more than seven zebras. But this problem can be handled if we assume a pragmatic rule that enforces maximally informative readings, as the sentence *x saw n zebras* is more informative than *x saw n' zebras*, if $n > n'$ (cf. Krifka 1986, 1989).

To cover collective readings, as e.g., *John and Mary (jointly) own three houses*, we need of course a different representation, which will not be developed here. And it should be clear that distributive readings can be treated in this framework as well (cf. Link 1983 for distributivity in lattice model structures).

Uniqueness of objects has been discussed by several authors. For example, it corresponds to “thematic uniqueness” in Carlson 1984 and “uniqueness of role-bearers” in Dowty 1987, and it is a requirement for the treatment of thematic relations as functions, as e.g., in Link 1987. Furthermore, Carlson suggests that thematic roles may serve to discriminate events from one another on the basis of this property and the discrimination of objects involved in the events: If θ is unique for objects, then we can infer from $\theta(e_1, x_1) \wedge \theta(e_2, x_2) \wedge \neg x_1 = x_2$ that $\neg e_1 = e_2$. But note that I do not assume uniqueness of objects for every thematic relation, as these authors seem to do. Obviously, it does not hold for the stimulus relation, as e.g., I can see a zebra and, with the same event of seeing, see the mane of the zebra as well. And it does not obtain with affected objects, as e.g., I can touch a shoulder and a person with the same event of touching.

Next, consider *mapping to events* and *mapping to objects*, the two relations which constitute the core of the construction of the homomorphism from objects to events. They seem to be sound assumptions for gradual patient relations. Take as an example the reading of a book; every part of the book corresponds to a part of the reading and vice versa. With other thematic relations, these properties normally do not obtain; for example, there is no correspondence between parts of the person that is reading and the reading event. But note that as we can have sum individuals, it is possible that mapping to events and mapping to objects (as well as uniqueness of objects) apply to other thematic relations in certain circumstances as well. As an example, consider *see seven zebras*. Even if a single experiencer is involved, this predicate can be applied to events with different temporal structures, for example to events where seven zebras are seen simultaneously, or to the sum of seven consecutive events, in each of which a single zebra was seen. Now, in the second case, it does make sense to speak of mapping to events and mapping to objects, as for every part of the complex seeing event (down to the observings of single zebras) there is a part of the sum individual of the zebras which is seen in this event. Note that in cases like this one, predicates as ‘see seven zebras’ can be understood as telic; for example, (16) can be understood to say that the seven zebras were not seen simultaneously.

- (18) a. John *snědl* rybu.
 b. John *jedl* rybu když Mary vztoupila.
- (19) a. John *ate* a fish.
 b. John *was eating* a fish (when Mary came in).
- (20) a. John aß *einen Fisch*.
 b. John aß *an einem Fisch* (als Mary hereinkam).
- (21) a. John söi *kalan*.
 b. John söi *kalaa* (kun Mary tuli sisään).

Progressivity normally is considered to be a verb-oriented category. How is it possible, then, that it is marked on an argument of the verb? The theory developed here provides an answer, because it predicts that a change of the reference type of the nominal predicate will affect the temporal constitution of the complete construction. This I want to show more precisely.

Although progressivity seems to elude a satisfying model-theoretic semantic description, it is clear since Bennett and Partee 1972 that some notion of partiality is involved in it. As a first approximation, which suffices for our purposes, we can consider a predicate like *be drinking a glass of wine* as applying to events which are parts of events to which *drink a glass of wine* applies. That is, progressivity is associated with the following operator:

$$(22) \text{ PROG} = \lambda P \lambda e' \exists e [P(e) \wedge e' \sqsubseteq e]$$

On the other hand, one can assume that partitivity can be associated with a similar operator (cf. Bach 1986). For example, the partitive of 'fish' can be analyzed as referring to parts of a fish.

$$(23) \text{ PART} = \lambda P \lambda x' \exists x [P(x) \wedge x' \sqsubseteq x]$$

Although the partitive may be analyzed like this in languages as Finnish which have a clear partitive case marking, the German case probably has to be handled differently because partitive objects like *an einem Fisch* have a rather limited distribution. They should instead be analyzed as prepositional objects governed by the verb. We have to assume a lexical restructuring rule which takes verbs like (24a) with an accusative object and a patient theta role and transforms them into verbs like (24b) with a prepositional object and a "partitive" patient relation. The partitive patient relation is related to the normal patient relation as in (24c):

- (24) a. *essen* S/NP[*nom, ag*], NP[*acc, pat*]
 b. *essen* S/NP[*nom, ag*], NP[*an-obj, part-pat*]
 c. $\forall e, x [PART-PAT(e, x) \leftrightarrow \exists x' [PAT(e, x') \wedge x' \sqsubseteq x]]$

Now, consider the following two expressions, (25a) representing a verbal progressive (English style, e.g., *be eating a fish*), and (25b) representing a nominal progressive (Finnish or German style, e.g., *an einem Fisch essen*), with α as verbal predicate (*eat*), δ as nominal predicate (*a fish*), and θ as the specific thematic relation.

scenario of quantized subpredicates which need not be exactly specified, but which at least must qualify as being quantized, and this is all we need.

Uniqueness of events, finally, characterizes those patient relations which describe the coming into being and disappearing of objects, because there can be only one such event for every object. This is another property that should not be considered as a grammatical feature, but as an external fact about the world.

Note that with many *verba efficiendi*, we find a certain ambiguity: They can be either token-oriented and type-oriented, so to speak. For example, it is possible to write the same letter more than once, if one refers to the letter type, not to the letter token. Such type-oriented verbs were called "performance verbs" by Verkuyl (1972). The approach outlined here can be extended to type reference. Types may be considered as abstract entities with a part relation that corresponds to the part relation for concrete entities we considered so far. For example, if y, y' are types and $y' \sqsubseteq y$, and if a concrete object or event x realizes the type y , then there should be an object or event x' , $x' \sqsubseteq x$, that realizes type y' . The specific patient relation of performance verbs then describes the realization of a type. Verbs like *play* and *compose* (as in *play/compose a sonata*) have patient relations relating an event to types, whereas *write* can be analyzed as either token-oriented or type-oriented. We cannot assume uniqueness of events for the type-oriented patient relation of *write* and *play*, and therefore we can understand a predicate as *write a letter* as atelic in its performance reading and under an iterative interpretation, as e.g., in (17a). On the other hand, with the patient relation of *compose*, we should assume uniqueness of events, which explains why (17b) is bad.

- (17) a. The secretary wrote this letter for three years.
 b.*Scarlatti composed this sonata for three years.

In this paper, I cannot go into the semantics of types, or kinds, and their relation to tokens; see Krifka 1986 for a more elaborate treatment.

7 Progressive and Partitive

The framework developed so far can be extended in many different directions and applied to interesting problems. Here, I will treat two topics, namely the marking of progressives in Finnish and German and an interaction between aspect and definiteness in Slavic languages.

I start with progressives. There are two ways to mark progressives in natural language. Most often, it is marked by verbal morphology, or by a periphrastic verbal construction, as in Czech or English. Sometimes, it is marked by some special prepositional or partitive case marking of an NP, as in German or Finnish (cf. Moravcsik 1978 for the meaning of different object markings in general and Heinämäki 1984 for the partitive objects in Finnish):

8 Perfective and Definiteness

Let us now look at *definiteness in Slavic*. We have seen how a nominal predicate operator can have an effect that is similar to a verbal predicate operator. As the transfer of reference properties works in both directions, we should not be surprised to find the converse case as well, that is, a verbal predicate operator affecting the meaning of a nominal predicate. We observe this most clearly in Slavic languages. The observation and data in this section are based on Wierzbicka 1968 for Polish and Filip 1985 for Czech.

As it is well known, Slavic languages mark perfective aspect (or actionsart; the difference does not matter here), whereas they do not mark definiteness of the NP. For example, the Czech NP *víno* can mean either 'wine' or 'the wine', *hruška* can mean either 'a pear' or 'the pear', and *hrušky* can mean either 'pears' or 'the pears'.

- (27) a. *uno* i. $\lambda x[\textit{wine}(x)]$
 ii. $\lambda x[x = FU(\textit{wine}) \wedge \textit{wine}(x)]$
 b. *hruška* i. $\lambda x[\textit{pear}(x, 1)]$
 ii. $\lambda x[x = FU(\lambda x \textit{pear}(x, 1)) \wedge \textit{pear}(x, 1)]$
 c. *hrušky* i. $\lambda x[\textit{pears}(x)]$
 ii. $\lambda x[x = FU(\textit{pears}) \wedge \textit{pears}(x)]$

I represent definite NPs on the basis of a predicate P as predicates applying to the fusion of all P -elements, given that the predicate P applies to the fusion. For example, *the wine* will apply to the fusion of all wine quantities (which is a wine quantity as well, as *wine* is cumulative). Similarly, *the pears* will apply to the fusion of all pears. And *the pear* will apply to one pear if there is only one; otherwise, the fusion of the objects which fall under the predicate (*a pear*) would not fall under that predicate.

According to this interpretation, *hruška* is a quantized predicate in both readings, whereas the two readings of *víno* and *hrušky* differ in their reference type: in the definite reading, they are quantized (as they have singular reference), whereas in the indefinite reading, they are cumulative.

Now consider the following examples:

- (28) a. Ota pil víno.
 'Ota drank wine/?the wine' (imperfective)
 b. Ota vypil víno.
 'Ota drank the wine/*wine' (perfective)
- (29) a. Jedl hrušku.
 'He ate a pear/?the pear' (imperfective)
 b. Snědl hrušku.
 'He ate a pear/the pear' (perfective)

- (25) a. $\phi_v = \lambda e' \exists e, x [\alpha(e) \wedge \delta(x) \wedge \theta(e, x) \wedge e' \sqsubseteq e]$
 b. $\phi_n = \lambda e \exists x, x' [\alpha(e) \wedge \delta(x) \wedge \theta(e, x') \wedge x' \sqsubseteq x]$

We assume that θ is gradual and unique for events. At least in German, the progressive marking by prepositional phrase is possible only with verbs like *drink* or *write*, marginally possible with *read*, but impossible with *see* or *pat*:

- (26) a. Hans schrieb/?las an einem Brief.
 b.*Hans sah/streichelte an einer Katze.

Furthermore, the verbal predicate α should be divisive, that is, if it applies to an event, it applies to every part of it as well. Even if this is not exactly true, we can assume it in the general case.

A final point is worth mentioning. In (25), I used the general part relation instead of the proper part relation. I think that this captures the semantics of progressivity, but pragmatically one can infer from the use of the progressive form, which is more complex than the corresponding simple form, that the proper part relation holds. Therefore, we have to show that ϕ_v is similar to ϕ_n using the proper part relation.

Proof: First I show that for all e , $\phi_v(e) \rightarrow \phi_n(e)$. Let $\phi_v(e_2)$, then there is an e_1 with $\alpha(e_1)$ and $e_2 \sqsubset e_1$, and an x_1 with $\delta(x_1)$ and $\theta(e_1, x_1)$. Because α is divisive, it holds that $\alpha(e_2)$. With mapping to objects, uniqueness for objects and uniqueness for events, there is an x_2 with $x_2 \sqsubset x_1$ and $\theta(e_2, x_2)$. But then $\phi_n(e_2)$ holds, too. Secondly I show that for all e , $\phi_n(e) \rightarrow \phi_v(e)$. To do this, we have to make an additional assumption, namely that with all nominal progressives, the whole object is eventually subjected to the event (this means ignoring the problems of the imperfective paradox). Let $\phi_n(e_2)$, then $\alpha(e_2)$ holds, and there are x_2, x_1 with $\delta(x_1)$, $\theta(e_2, x_2)$ and $x_2 \sqsubset x_1$. Now the additional assumption is that there is an e_1 with $\alpha(e_1)$ and $\theta(e_1, x_1)$. Because of mapping to events, there is an e_3 with $\theta(e_3, x_2)$ and $e_3 \sqsubseteq e_1$. Because of uniqueness of objects, x_2 is the only x for which $\theta(e_3, x)$ holds, and because of uniqueness of objects, e_3 is the only e for which $\theta(e, x_2)$ holds, hence $e_3 = e_2$ and $\neg e_2 = e_1$ (because $\neg x_1 = x_2$), and therefore $e_2 \sqsubset e_1$. But then it holds that $\phi_v(e_2)$.

By this method, it can be explained how it is that a marking on the noun can serve to mark an essentially verbal category. Note that in Finnish the partitive is used in many more cases; it serves to express the progressive even with nouns like *read* and *buy*, and it may be employed to mark irresultative verbs, as e.g., *to shoot and wound* versus *to shoot dead*. This can be explained by an analogical extension of this type of marking to conceptually similar cases. The *tertium comparationis* of this extension is that the expression with a partitive object denotes an event which is not as complete as an event denoted by the corresponding expression with an accusative object.

slight meaning differences. But quantization is at least a component of the meaning of perfectivity. There seem to be interesting variations between languages in what has been called "perfectivity." Singh (1991), for example, argues that perfectives in Hindi are not related to quantization, but to atomicity of the basic predicate.

9 Some Final Remarks

To summarize, I hope to have made it clear that a semantic representation is feasible in which the intuitive similarities between the reference type of noun phrases and the temporal constitution of verbal expressions is captured in a simple way. I have shown how the reference type of a noun phrase can affect the temporal constitution of a verbal expression and vice versa. I have discussed the properties of thematic relations that allow this transfer of reference properties. Finally, I have applied these insights to explain the marking of progressives by the case of NPs, and the effects of aspect to the definiteness of NPs.

In Krifka 1989, I have shown how the theory can be extended to cover quantification and negation. Furthermore, I have explained why durative adverbials like *for an hour* and time-span adverbials like *in an hour* select for cumulative and quantized event predicates, respectively. In Krifka 1986, I also treated the influence of locative and directional adverbials on the temporal constitution of a complex verbal expression with examples such as *walk to the school in/*for an hour* versus *walk towards the school *in/for an hour*. In Krifka (1990), I have shown how measure expressions in nominal constituents can express a measure on events. For example, the sentence '4000 ships passed through the lock last year' has a reading in which it does not imply that there are 4000 ships that passed through the lock, but that there were 4000 events of passing of a single ship. Another area of application is the semantics of the frequentative aktionsart; in many languages, it remains unspecified whether a sentence with a frequentative predicate claims that there is more than one event or more than one participant in an event, an ambiguity which can be rendered easily in our semantic representation.

References

- Austin, John. 1961. Truth. In *Philosophical Papers*, 117-133. Oxford: Oxford University Press.
- Bach, Emmon. 1986. The Algebra of Events. *Linguistics and Philosophy* 9:5-16.
- Bäuerle, Rainer. 1979. *Temporale Deixis, Temporale Frage*. Tübingen: Gunter Narr.
- Bennett, Michael, and Barbara Partee. 1972. *Toward the Logic of Tense and Aspect in English*. Bloomington: Indiana University Linguistics Club.
- Carlson, Gregory N. 1984. Thematic Roles and their Role in Semantic Interpretation. *Linguistics* 22:259-279.

- (30) a. Jedl hrušky.
'He ate pears/?the pears' (imperfective)
- b. Snědl hrušky.
'He ate the pears/*pears' (perfective)

These data can be interpreted as follows: (28) and (30) show that aspect marking can distinguish between the indefinite and the definite reading of mass nouns and bare plurals, as the perfective aspect is compatible only with the definite interpretation of the object. (29) shows that a verb in the perfective aspect may have an indefinite object if this object is quantized. Hence it is not definiteness, but quantization which is required by the perfective aspect marking.

The data can be explained as follows: Let us assume that the perfective operator has scope over the complex verbal predicate. One of its meaning components is that the predicate it applies to is quantized. That is, at least part of the meaning of the perfective can be captured by the modifier $\lambda P\lambda e[P(e) \wedge QUA(P)]$. This follows from the usual assumptions for perfectivity which says that it conveys the meaning that an event is "completed." This makes sense only for events which are quantized (or have a set terminal point), as events under a cumulative description have no set terminal point and hence cannot be said to be completed.

If we assume the normal transfer properties for the object role of verbs like *eat* and *drink*, then we see that only with a quantized object the complex verbal predicate will be quantized as well. If the perfective aspect forces a quantized interpretation of the complex verbal predicate, the complex verbal predicate will again force a quantized interpretation of the object NP. This means in the case of (28b) and (30b) the definite interpretation of the object, as this is the only quantized interpretation (note that all singular predicates are quantized). In the case of (29b), we can assume both the definite and the indefinite interpretation, as the latter one will also yield a quantized object.

In a similar way, the imperfective aspect may force a non-quantized interpretation of the verbal predicate, which consequently enforces a non-quantized interpretation of the object NP. However, this requirement seems to be much weaker.

Note that the treatment of the Slavic definiteness marking proposed here is essentially compositional, although the phenomenon itself seems not to be compositional at first sight, as the interpretation of *vino* depends on other constituents. It is simply that the unwelcome reading is excluded by general principles, just as in *rob the bank* the unwelcome readings of *bank* are excluded by the lexical meaning of *rob*.

It should be stressed here that perfectivity is not just an expression of quantization. If it were just this, we could not explain why languages typically use a variety of perfectivity markers, even for the same verb, with

- Krifka, Manfred. 1990. Four Thousand Ships Passed Through the Lock: Object-Induced Measure Functions on Events. *Linguistics and Philosophy* 13:487-520.
- Leisi, Ernst. 1953. *Der Wortinhalt. Seine Struktur im Deutschen und Englischen*. Heidelberg: Quelle und Mayer.
- Link, Godehard. 1983. The Logical Analysis of Plurals and Mass Terms: A Lattice-Theoretical Approach. In *Meaning, Use, and Interpretation of Language*, ed. Rainer Bäuerle, Christopher Schwarze, and Arnim von Stechow, 302-323. Berlin: Mouton.
- Link, Godehard. 1987. Algebraic Semantics for Event Structures. In *Proceedings of the 6th Amsterdam Colloquium*, ed. Jeroen Groenendijk, Martin Stokhof, and Frank Veltman, 243-262. University of Amsterdam. Institute for Language, Logic, and Information.
- Lønning, Jan Tore. 1987. Mass Terms and Quantification. *Linguistics and Philosophy* 10:1-52.
- Moravcsik, Edith. 1978. On the Case Marking of Objects. In *Universals of Human Languages, Vol. 4*, ed. Joseph H. Greenberg, 249-289. Stanford University Press.
- Parsons, Terence. 1980. Modifiers and Quantifiers in Natural Language. *Canadian Journal of Philosophy* (Suppl) 4:29-60.
- Platzack, Christer. 1979. *The Semantic Interpretation of Aspect and Aktionsarten: A Study of Internal Time Reference in Swedish*. Dordrecht: Foris.
- Quine, Willard V. 1960. *Word and Object*. Cambridge, Mass.: MIT Press.
- Scha, Remko. 1981. Distributive, Collective, and Cumulative Quantification. In *Formal Methods in the Study of Language, Vol. 2*, ed. Jeroen Groenendijk, Theo Janssen, and Martin Stokhof, 483-512. Amsterdam: Mathematisch Centrum.
- Singh, Mona. 1991. The Perfective Paradox, or: How to Eat a Cake and Have It, Too. In *Proceedings of the 17th Annual Meeting of the Berkeley Linguistic Society*. University of California at Berkeley.
- ter Meulen, Alice. 1984. Events, Quantities, and Individuals. In *Varieties of Formal Semantics*, ed. Frederick Landman and Frank Veltman, 259-280. Dordrecht: Foris.
- Vendler, Zeno. 1957. Verbs and Times. *Philosophical Review* 66:143-160. (Also in Vendler 1967, pp. 97-121.)
- Vendler, Zeno. 1967. *Linguistics in Philosophy*. Ithaca: Cornell University Press.
- Verkuyl, Henk J. 1972. *On the Compositional Nature of the Aspects*. Dordrecht: Reidel.
- Wierzbicka, Anna. 1967. On the Semantics of the Verbal Aspect in Polish. In *To Honor Roman Jakobson: Essays on the Occasion of his Seventieth Birthday, Vol. 2*, 2231-2249. Den Haag: Mouton.
- Davidson, David. 1967. The Logical Form of Action Sentences. In *The Logic of Decision and Action*, ed. Nicholas Rescher, 81-95. Pittsburgh: Pittsburgh University Press.
- Dowty, David. 1979. *Word Meaning and Montague Grammar*. Dordrecht: Reidel.
- Dowty, David. 1987. Events, Aspects, and NP Semantics. Paper presented at the Conference on Logic and Linguistics, July 1987, Stanford University.
- Dowty, David. 1989. On the Semantic Content of the Notion "Thematic Role". In *Properties, Types and Meaning, Vol. 2: Semantic Issues*, ed. Gennara Chierchia, Barbara Partee, and Raymond Turner. Dordrecht: Kluwer.
- Fauconnier, Gilles. 1978. Implication Reversal in a Natural Language. In *Formal Semantics and Pragmatics for Natural Language*, ed. Franz Guenther and S. J. Schmidt, 289-301. Dordrecht: Reidel.
- Filip, Hana. 1985. Der Verbalaspekt und die Aktionsarten dargelegt am Beispiel des Tschechischen. Master's thesis, Universität München.
- Fillmore, Charles. 1968. The Case for Case. In *Universals in Linguistic Theory*, ed. Emmon Bach and Robert T. Harms, 1-90. New York: Holt, Rinehart and Winston.
- François, Jean. 1985. Aktionsart, Aspekt und Zeitkonstitution. In *Handbuch der Lexikologie*, ed. Christopher Schwarze and Dieter Wunderlich, 229-249. Kronberg: Athenaeum.
- Garey, Howard B. 1957. Verbal Aspects in French. *Language* 33:91-110.
- Gillon, Brendan S. 1987. The Readings of Plural Noun Phrases in English. *Linguistics and Philosophy* 10:199-220.
- Gruber, Jeffrey S. 1976. *Lexical Structures in Syntax and Semantics*. Amsterdam: North Holland. Includes 1965 MIT PhD thesis, *Studies in Lexical Relations*; reissued by Indiana University Linguistics Club (Bloomington, 1970).
- Heinämaäki, Orvokki. 1984. Aspect in Finnish. In *Aspect Bound: A Voyage into the Realm of Germanic, Slavonic and Finno-Ugrian Aspectology*, ed. Casper de Groot and Hannu Tommola, 153-178. Dordrecht: Foris.
- Hinrichs, Erhard. 1985. *A Compositional Semantics for Aktionsarten and NP Reference in English*. Doctoral dissertation, Ohio State University.
- Hoepelman, Jakob. 1976. Mass Nouns and Aspects, or: Why We Can't Eat Gingercake in an Hour. In *Amsterdam Papers in Formal Grammar 1*, ed. Jeroen Groenendijk and Martin Stokhof, 132-154. Universiteit van Amsterdam. Centrale Interfaculteit.
- Hoepelman, Jakob, and Christian Rohrer. 1980. On the Mass-Count Distinction and the French Imparfait and Passé Simple. In *Time, Tense, and Quantifiers*, ed. Christian Rohrer. Tübingen: Niemeyer.
- Krifka, Manfred. 1986. *Nominalreferenz und Zeitkonstitution. Zur Semantik von Massentermen, Pluraltermen und Aspektklassen*. Doctoral dissertation, Universität München. Published 1989, München: Fink.
- Krifka, Manfred. 1989. Nominal Reference, Temporal Constitution and Quantification in Event Semantics. In *Semantics and Contextual Expressions*, ed. Renate Bartsch, Johan van Benthem, and Peter van Emde Boas, 75-115. Foris: Dordrecht.