

Title	Theoretical Prediction for High Quality Products and Reliable Assembly Process(Mechanics, Strength & Structure Design, INTERNATIONAL SYMPOSIUM OF JWRI 30TH ANNIVERSARY)
Author(s)	Murakawa, Hidekazu
Citation	Transactions of JWRI. 32(1) P.207-P.213
Issue Date	2003-07
Text Version	publisher
URL	<a href="http://hdl.handle.net/11094/6801">http://hdl.handle.net/11094/6801</a>
DOI	
rights	本文データはCiNiiから複製したものである
Note	

***Osaka University Knowledge Archive : OUKA***

<https://ir.library.osaka-u.ac.jp/>

Osaka University

# Theoretical Prediction for High Quality Products and Reliable Assembly Process<sup>†</sup>

MURAKAWA Hidekazu\*

## Abstract

*The mechanical behavior, such as deformation, stress and strain, is important in understanding the complex phenomena in welding as well as the physics and the metallurgy. Welding residual stress and distortion are the subjects mostly discussed as mechanical problems. Cracking during welding and the fracture of the joint under external load are also important problems. To study these problems, theoretical predictions using numerical models are effective in many cases. The potential usefulness of numerical simulations for industrial application is demonstrated through examples in this report.*

**KEY WORDS:** (Finite Element Method) (Simulation) (Hot Cracking) (Resistance Welding) (Welding Distortion) (Joint) (Interface Element)

## 1. Introduction

Joining and welding technology has two aspects. One is to join parts efficiently without defects such as blowholes, inclusions and cracks. Second is to ensure the performance of the structure as a whole throughout its lifetime under various loadings and environments. These two can be mapped on the scales of time and dimension.

In terms of the time, the melting and solidification of the metal take place. Then, by repeating the joining of parts, the structure or the product is assembled. The product is transported to the location or the site where it is expected to serve. It may deteriorate due to aging but it must withstand the loading and the environment for its full life.

With respect to the dimension, the problems are roughly divided into three scales. One is the scale of small particles, where electrons and photons play an important role in generating and transmitting energy. The energy supplied to the metal produces the weld pool which has the second scale. The solidification and the phase transformation of materials, formation of cracking and residual stress belong to this scale or even smaller. The welding distortion of the overall structure belongs to the largest scale. Thus, the problems we must tackle are spread widely both in time and space.

Before dealing with these problems, we must make

clear what engineers want to know. Engineers in the industry have many questions related to welding. Among them, the following three questions are the most fundamental and important.

- (1) How to produce a sound weld without defects, such as blowholes and cracks?
- (2) How to achieve high productivity?
- (3) How to ensure the performance of welded structures under various loadings and environments?

The answer to the above questions can be given from three or four aspects.

- (1) Choice of welding method and welding conditions
- (2) Choice of materials
- (3) Change of joint and structural design
- (4) Combination of above three

In general, decision made based on any one of the above three may have influence on the remainder. The interactions among them must be taken into account especially when the level of requirement is high. Some examples of such effort are presented in this report.

## 2. Simulation of Joining Process

### 2.1 Deformation analysis in national research project

Welding is a very complex process which involves various phenomena, such as heat generation, mass and

<sup>†</sup> Received on January 31, 2003

\* Professor

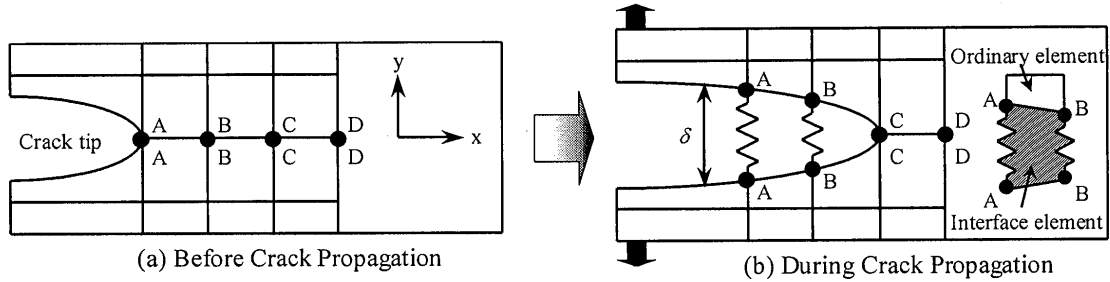

Fig.2 Representation of crack extension using interface element.

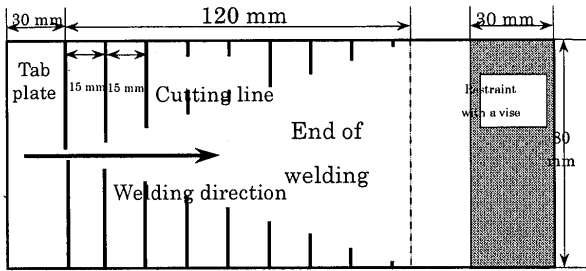

Fig.1 Houldcroft hot cracking test specimen.

heat transfer, melting and solidification, phase transformation of materials and formation of stress and distortion. Though it is complex, it is necessary to make efforts to understand it based on rational theory so that right decisions in selecting the welding conditions or the materials can be made.

As one of such efforts, a national project of "Development of Highly Efficient and Reliable Welding Technology" has been conducted jointly by several research groups including JWRI. It is supported by the New Energy and Industrial Technology Development Organization (NEDO) through the Japan Space Utilization Promotion Center (JSUP) in the program of Ministry of International Trade and Industry (MITI). The primary objective of this project is to develop theoretical models of welding in which the interaction among welding physics, metallurgy and mechanics are considered.

In most existing researches on welding mechanics, the heat input distribution and material properties are assumed as known variables and they are determined based on experiments. However, the heat input distribution has a great influence on the residual stress and the distortion produced by welding and it changes with the penetration shape. Thus, a numerical simulation method for the prediction of welding distortion considering the coupling among the welding process, the phase transformation of materials and the stress-strain fields is planned to be developed.

## 2.2 Hot cracking in arc welding

In order to evaluate the hot cracking susceptibility, Houldcroft and Trans-Varestraint tests are widely used.

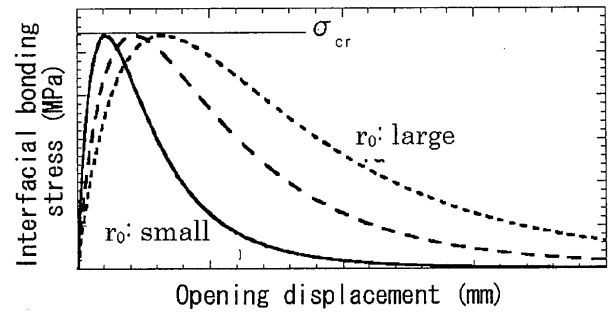

Fig.3 Temperature dependent yield stress ( $\sigma_y$ ) and critical strength ( $\sigma_{cr}$ ) of interface element.

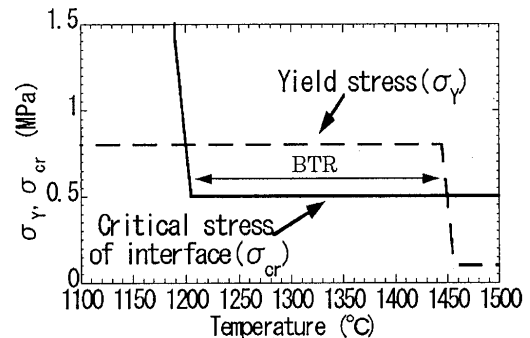

Fig.4 Stress-opening displacement curves of interface element.

Figure 1 shows a schematic illustration of Houldcroft tests. In the case of the Houldcroft test, the hot cracking susceptibility is evaluated by the crack length. Thus it is necessary to simulate all processes of crack formation, its extension and arrest. For this, a finite element method (FEM) employing temperature dependent interface elements is developed.

The interface element is basically a nonlinear spring element and it is arranged along the plane or the line where a crack is formed as shown in Fig.2. The mechanical property of the interface element is defined through an interface potential function  $\phi$ . The derivative of  $\phi$ , with respect to the opening displacement at the interface  $\delta$  gives the interfacial bonding stress  $\sigma$ . The relation between the interfacial bonding stress and the opening displacement is shown in Fig.3. When the opening displacement is small, the stress increases with the displacement and bonding is maintained. After

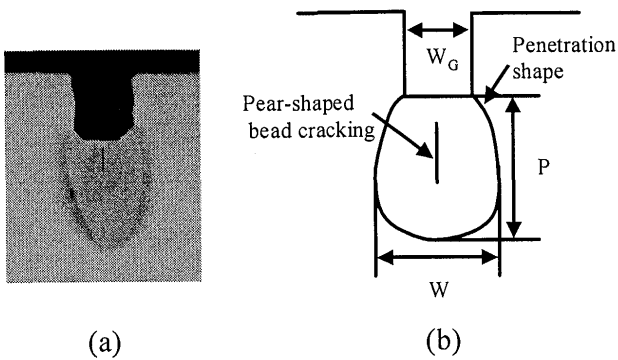

Fig.5 Pear shaped bead cracking and parameters of penetration shape.

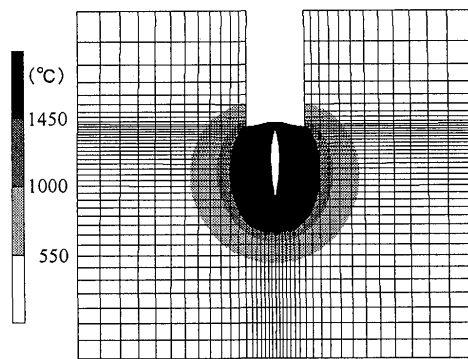

Fig.6 Simulated pear shaped bead cracking.

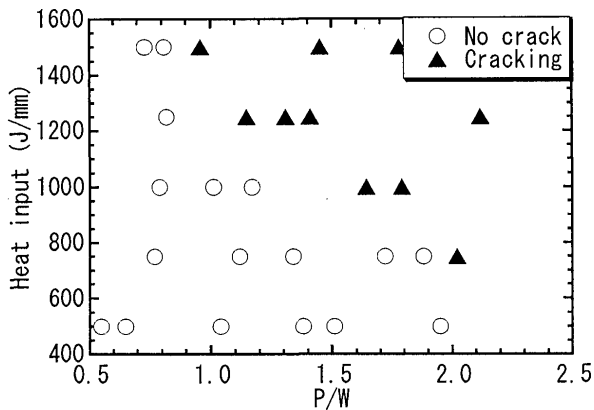
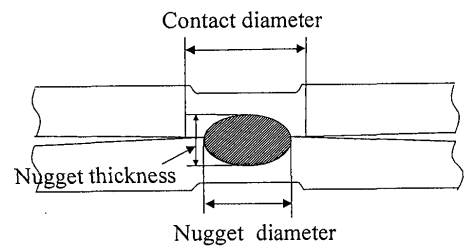

Fig.7 Influence of heat input and P/W on formation of pear shaped bead cracking.

reaching the maximum value  $\sigma_{cr}$ , the bonding stress reduces with the opening displacement. With further increase of the displacement, the bonding between the surfaces is lost or the crack is formed. By arranging such interface element as in Fig.2, all the processes from the formation of the crack to its arrest can be simulated in a natural manner. On the other hand, the brittleness temperature range (BTR) can be modelled as the temperature range in which the critical stress  $\sigma_{cr}$  exceeds the yield stress  $\sigma_Y$  as shown in Fig.4. Using this method, the Houldcroft and the Trans-Varestraint tests can be simulated.

The same method can be applied to simulate the



$$\text{Nugget diameter} \geq \text{Contact diameter}$$

Fig.8 Definition of expulsion in computation.

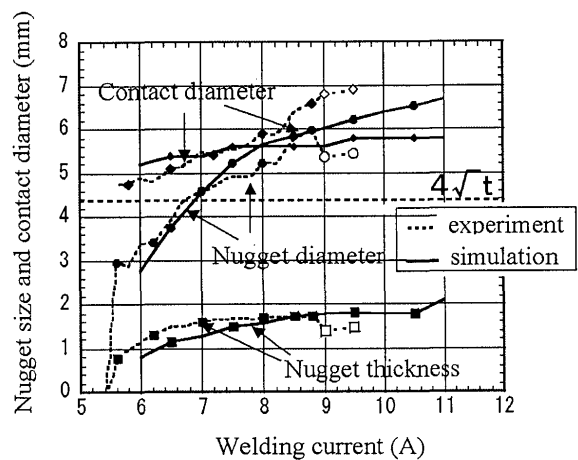

Fig.9 Time histories of nugget and contact diameters.

formation of the pear shaped bead cracking as shown in Fig.5. Figure 6 is the example of cracking simulated by FEM. Series of computations are conducted and the influence of the heat input and the aspect ratio of the penetration  $P/W$  is summarized in Fig.7. The cracking is likely to occur when both heat input and  $P/W$  are large.

### 2.3 Resistance spot and seam weldings

Compared to the arc welding, the resistance welding, such as spot welding and seam welding, are simple in terms of physics. The heat is generated through Joule heating. The heat generation is governed by the current density which is closely related to the area of contact between parts. Thus, the coupling between the deformation field and the heat generation is much stronger than in the arc welding. The complete process of the resistance welding can be simulated as a coupling problem among the electric, the thermal and the deformation fields<sup>1)</sup>. The merits of the simulation are,

- (1) Information not available from experiment can be obtained.
- (2) There are no physical limitation, such as the size, the time and the temperature.
- (3) Test under ideal conditions is possible.

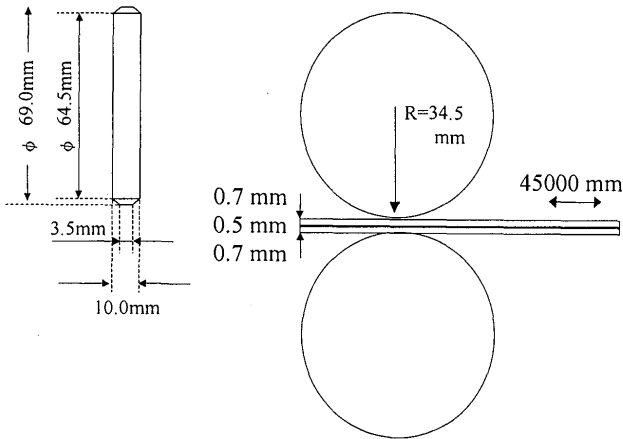

Fig.10 Seam welding model.

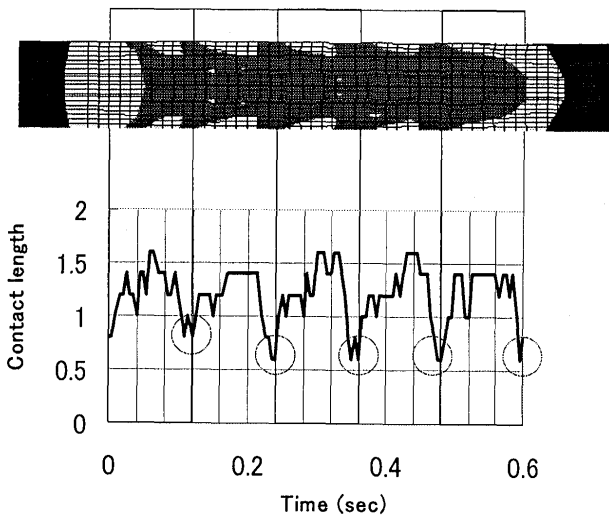

Fig.11 Relation between nugget formation and contact between electrode/work.

- (4) Cost and time can be saved.
- (5) The number of experiments can be saved.

In case of the spot welding, the goal is to produce the nugget with sufficient size and without expulsion. The expulsion occurs when the nugget diameter exceeds that of the contact area as shown in Fig.8. Since both the nugget and the contact area, which are invisible physically, can be traced precisely in simulation, the expulsion can be detected as shown in Fig.9. Similarly, Figs.10 and 11 shows the seam welding model and the relation between the nugget formation and the contact length between electrode and work<sup>2)</sup>.

### 3. Simulation for High Productivity

The distortion during welding assembly reduces not only the geometrical precision of the product but also the productivity. The influential factors of the distortion are the local deformation produced by the welding thermal cycle, the cutting error, welding sequence and the restraints or the fixtures. The contributions of these

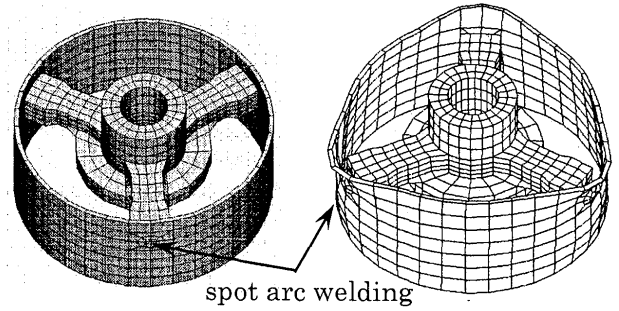

Fig.12 Welding deformation of compressor part under arc spot welding.

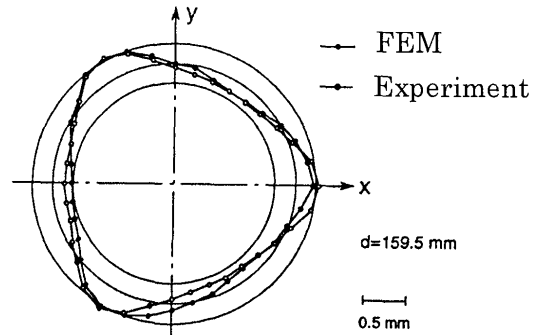

Fig.13 Comparison between FEM and experiment.

factors to the distortion are not quantitatively understood yet, especially in the case of large curved structures such as ships.

To predict the welding distortion, there are two alternative methods. One is direct simulation using Thermal-elastic-plastic FEM which can provide detailed information during the welding process. It is suitable for small and simple structures as the compressor shown in Figs.12 and 13 which are assembled by the arc spot welding<sup>3)</sup>.

The other method is the elastic FEM using the concept of the inherent strain or the inherent deformation<sup>4)</sup>. Local deformations, such as the angular distortion, the transverse shrinkage and the longitudinal shrinkage, are produced along the welding line. The magnitudes of these local deformations are governed mostly by the heat input parameter  $Q/h^2$ , where  $Q$  is the heat input and  $h$  is the thickness of plate<sup>5)</sup>. For this reason these deformations can be called as inherent deformations. Figures 14 and 15 show the relation between the angular distortion and the transverse shrinkage with the parameter  $Q/h^2$ .

In case of large plate structures, such as ships and bridges, the welding lines are fairly long. If the welding lines are long enough, the inherent deformations can be assumed to distribute uniformly and their values can be determined according to the curves given by Figs.14 and 15. These inherent deformations are given to the elements along the welding line in the form of equivalent

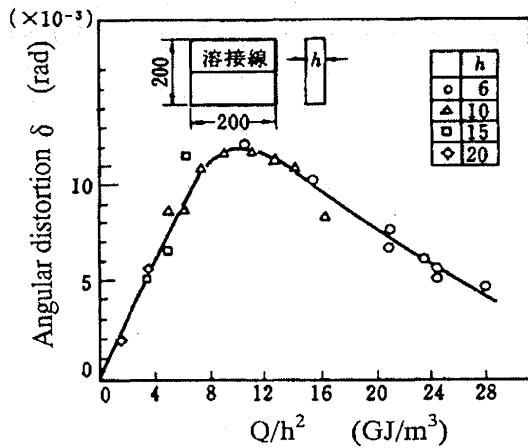

Fig.14 Relation between angular distortion and parameter  $Q/h^2$ .

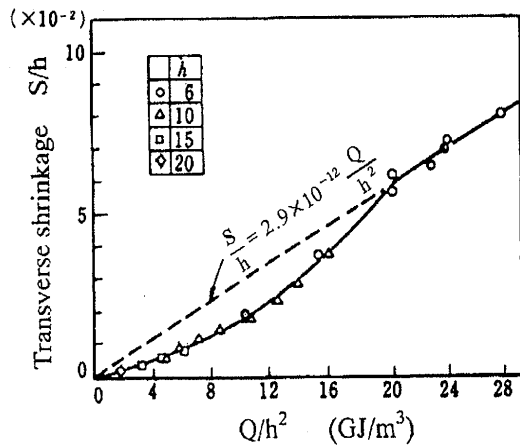

Fig.15 Relation between transverse shrinkage and parameter  $Q/h^2$ .

inherent strain (initial strain) as shown in Fig.16. The deformation of the structure due to welding is computed as an elastic deformation analysis using FEM.

However, the inherent deformation is just one of the causes for the distortion of the structure during assembly. The possible reasons for the distortion are,

- (1) cutting error
- (2) local deformation due to welding (inherent deformation)
- (3) positioning or fitting of parts
- (4) gap correction
- (5) fixture

To take into account the positioning, the gap correction and the welding sequence in addition to the local deformation due to welding, the author's research group developed an elastic FEM. In this method, the local deformation and the gap are considered using the inherent strain and the interface element, respectively<sup>6)</sup>.

The influence of gap correction on the distortion of a plate structure is investigated using the proposed FEM. The structure has an asymmetric curved shape. Three

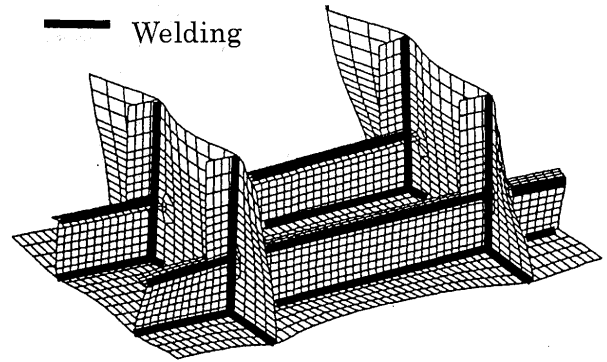

Fig.16 Prediction of welding distortion of medium size structure.

cases in Figs.17-19, namely without gap, with end gap and with center gap, are compared. As shown in Fig.20, the structure is twisted by the welding itself. When the end type gap exists between the longitudinal stiffeners and the skin plate (Case B), the twisting deformation is produced by gap correction. Then the welding deformation is superposed and the final deformation becomes bigger than in case A as shown in Fig.22. This example shows that the influence of gap cannot be ignored for the accurate prediction of distortion during assembly process.

#### 4. Prediction of Mechanical Performance of Joints

##### 4.1 Simulation of ductile fracture

Ductile fracture can start from the location where the stress or the strain is concentrated, such as the notch and the geometrical discontinuity associated with the weld joint. The same interface element proposed for the weld hot cracking can be employed to simulate the fracture problems<sup>7)</sup>. The first example is the ductile fracture of a steel plate with a center notch as shown in Fig.23. The interface elements are arranged along the path of the crack extension. Figure 24 shows the process of the crack extension computed using the interface element.

##### 4.2 Strength of bonded joint between dissimilar materials

The second example is the prediction of the strength of the joint between steel and resin. Figure 25 shows the rectangular specimen to be analyzed. The steel and the resin are directly bonded at the center. The angle of the bonding line  $\theta$  is changed from 30 to 150 degree to clarify the effect of the scarf angle on the bonding strength. The mechanical property of the interface is characterized by two parameters. One is the surface energy  $\gamma$  necessary to produce a new surface and the other is the scale parameter  $r_0$ . In the serial computations, the scale parameter  $r_0$  is systematically changed. The computed results are summarized in Fig.26. As seen

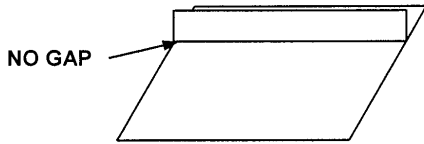

Fig.17 Gap assumed in case A.

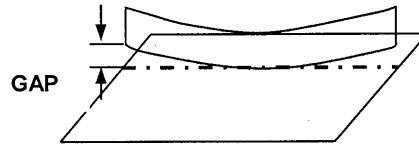

Fig.18 Gap assumed in case B.

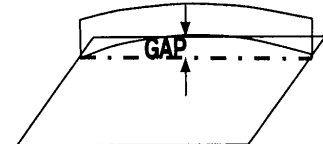

Fig.19 Gap assumed in case C.

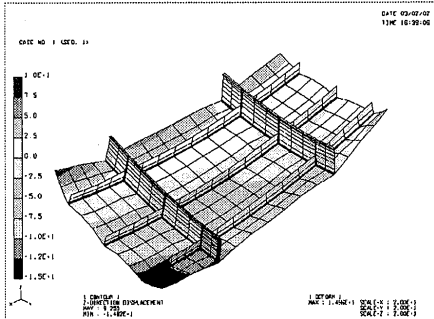

Fig.20 Welding deformation in case A.

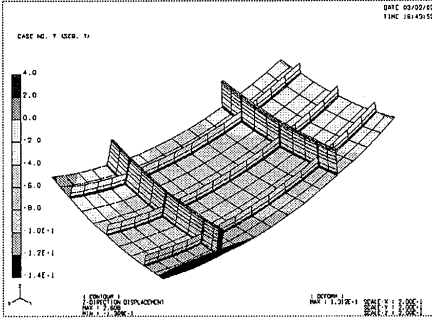

Fig.21 Deformation after gap correction in case B.

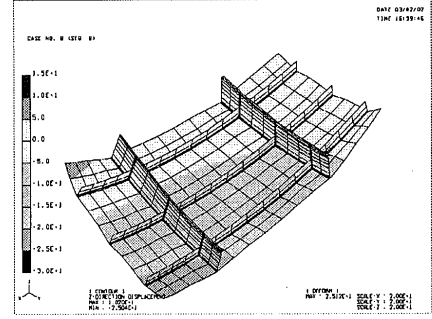

Fig.22 Final deformation of case B.

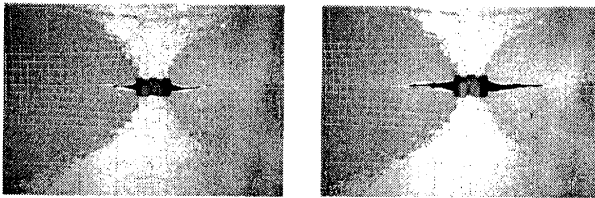

Fig.23 Crack extension process in experiment.

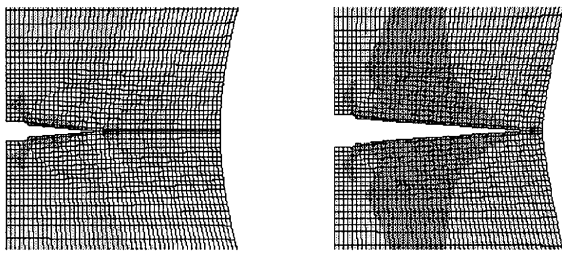

Fig.24 Crack extension process in experiment.

from the figure the strength of the joint changes with the scarf angle  $\theta$ . This is related to the order of the singularity in the stress field at the edge of the joint. The strength reaches the maximum when the scarf angle is larger than 120 degree where the singularity vanishes.

### 5. Conclusions

As demonstrated through examples, the numerical simulation of mechanical problems in welding can provide valuable information useful for solving practical problems in industry. The author believes that simulation is one of the most important tools for joining and welding solutions.

### References

1) H. Murakawa, J. Zhang and H. Minami: FEM Simulation of Spot Welding Process (Report III) -Controlling of Welding Current Using Electrode Displacement for

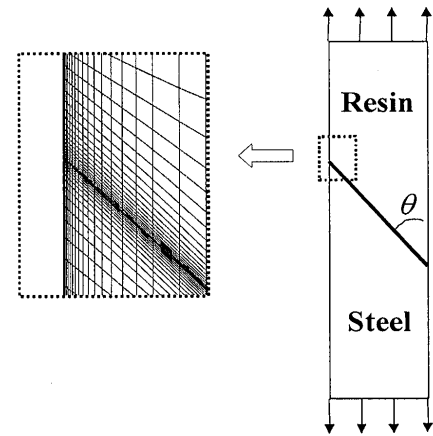

Fig.25 Steel/resin joint model.

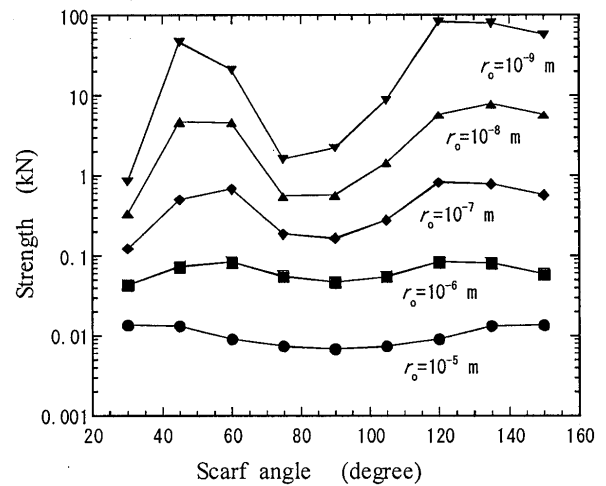

Fig.26 Influence of scarf angle on joint strength.

Formation of Large Enough Nugget without Expulsion-, Trans. JWRI, Vol. 28 (1999), No. 1, pp.41-46.

2) H. Murakawa, H. Minami and T. Kato: Finite Element Simulation of Seam Welding Process, Trans. JWRI, Vol. 30 (2001), No. 1, pp.111-117.

3) M.G. Yuan, J. Wang, H. Murakawa and Y. Ueda :

Development of Finite Element Program of Three Dimensional Thermal-Elastic-Plastic Analysis and Its Application to Assembly of Compressor by Welding, Quarterly Journal of JWS, Vol.13 (1995), No.4, 628-634 (in Japanese).

- 4) H. Murakawa, Y. Luo and Y. Ueda : Inherent Strain as an Interface between Computational Welding Mechanics and Its Industrial Application, Mathematical Modelling of Weld Phenomena 4, Ed. H. Cerjak (1998), 597-619.
- 5) K. Satoh and T. Terasaki : Effect of Welding Conditions on Welding Deformations in Welded Structural Materials,

Journal of the Japan Welding Society, Vol.45, No.4 (1976), 302-308 (in Japanese).

- 6) D. Deng, H. Serizawa and H. Murakawa: FEM Simulation of Welding Distortion in Thin Curved Structures during Assembly Considering Gap and Misalignment, Trans. JWRI, Vol. 31, (2002), No. 2, pp.219-226.
- 7) H. Murakawa and Z.Q. Wu: Computer Simulation Method for Crack Growth Using Surface Energy and its Application to Interface Stripping of Composite Material, J. Kansai Soc. N. A., No. 230 (1998), pp.247-255.