

## Thermal Diffusivity of $Mg_2SiO_4$ , $Fe_2SiO_4$ , and NaCl at High Pressures and Temperatures

HIDEYUKI FUJISAWA,<sup>1</sup> NAOYUKI FUJII,<sup>2</sup> HITOSHI MIZUTANI,<sup>2</sup>  
HIROO KANAMORI,<sup>3</sup> AND SYUN-ITI AKIMOTO

*Institute for Solid State Physics, University of Tokyo, Tokyo, Japan*

The pressure and temperature variations of thermal diffusivity of polycrystalline  $Mg_2SiO_4$  have been measured for the range 24 to 50 kb and 400° to 1300°K. Effect of the olivine-spinel phase transition on thermal diffusivity of  $Fe_2SiO_4$  was studied at 48.5 kb for the temperature range 350° to 650°K. Synthetic samples with grain size 1 to 5 microns were used. For the pressure range studied, the reciprocal of thermal diffusivity  $1/\kappa$  of  $Mg_2SiO_4$  increases almost linearly with temperature up to about 1200°K, as expected from the theory of phonon conduction, but is nearly constant above that temperature. The  $1/\kappa$  versus temperature curve of  $Fe_2SiO_4$  (olivine) is nearly straight up to 700°K, where it becomes slightly convex. The thermal diffusivity of NaCl is measured under similar conditions for comparison with Bridgman's data. The agreement is reasonably good. The pressure derivative  $\partial\kappa/\partial P$ , at  $P = 40$  kb is  $1.8 \times 10^{-4}$  cm<sup>2</sup>/sec kb (at 700°K) and  $0.8 \times 10^{-4}$  cm<sup>2</sup>/sec kb (at 1100°K) for  $Mg_2SiO_4$ , and  $4.7 \times 10^{-4}$  cm<sup>2</sup>/sec kb (at 700°K) for NaCl. This pressure dependence can be explained by the theory of phonon conduction. The thermal diffusivity of  $Fe_2SiO_4$  (spinel) is about 1.5 times that of  $Fe_2SiO_4$  (olivine) over the range 350° to 650°K. The effect of radiative heat transfer in  $Mg_2SiO_4$  is discussed. The photon mean free path is estimated to be 0.3 mm at 1400°K.

### INTRODUCTION

Knowledge of the temperature and pressure variations of thermal properties of rocks and minerals is indispensable for quantitative discussions of the earth's thermal problems. A number of investigations have been made along this line. *Bridgman* [1924] measured thermal conductivities of several rocks and glasses and determined their dependence on pressure up to 12 kb at 30° and 75°C. Recently *Hughes and Sawin* [1967] measured thermal conductivity of dielectric solids to pressures of 19 kb. Thermal conductivities were found to increase nonlinearly with pressure, although their results for dunite and eclogite showed a large scatter.

*Clark* [1941] and *Walsh and Decker* [1966] discussed the effect of porosity on thermal conductivity of rocks. The pressure effect on phonon thermal conductivity was theoretically discussed by *Lawson* [1957]. Measurements

at high temperatures have also been made on materials of geophysical interest [*Birch and Clark*, 1940a, b; *Kingery*, 1962; *Kawada*, 1964, 1966; *Kanamori et al.*, 1968]. The results were discussed in relation to composition, crystal boundary effect, porosity, and opacity. Experimental data are still insufficient, however, for establishing the variation of thermal conductivity at high pressures and temperatures. This paper presents experimental data of thermal diffusivities of  $Mg_2SiO_4$  and  $Fe_2SiO_4$ , most important minerals in the earth's mantle, at elevated pressures and temperatures. Measurements are also made on NaCl for comparison with the *Bridgman's* [1924] result.

### METHOD

The Angström method [*Carslaw and Jaeger*, 1959, p. 136] is suitable for the measurement of small samples. We modified the method to make it applicable to cylindrical samples. The sample assembly is shown schematically in Figure 1. The powdered sample is packed in a graphite tubing, which not only serves as a heating element but also generates a sinusoidal temperature wave. The ratio of the length to the radius of the sample is 6 to 8

<sup>1</sup>Now at Earthquake Research Institute, University of Tokyo.

<sup>2</sup>On leave from Geophysical Institute, University of Tokyo.

<sup>3</sup>On leave from Earthquake Research Institute, University of Tokyo.

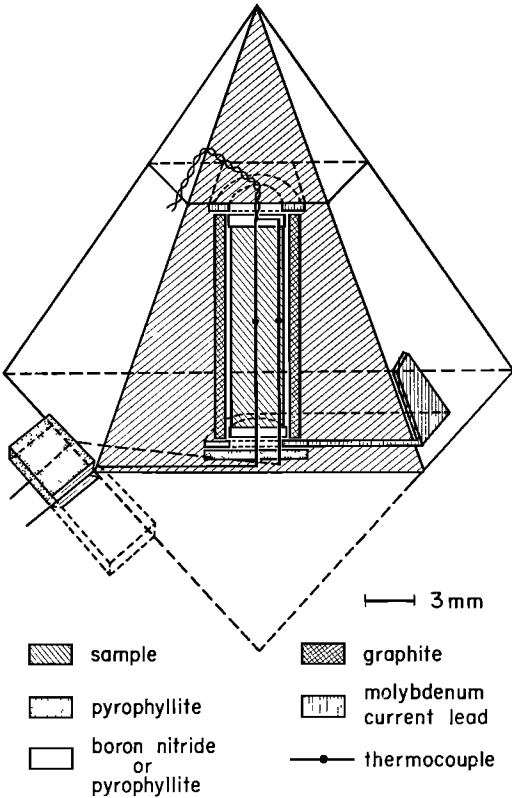

Fig. 1. Schematic diagram of sample assembly embedded in pyrophyllite tetrahedron.

so that the heat flux in the axial direction can be ignored. The time-dependent equation of heat transfer in this case can be written as

$$\frac{\partial T}{\partial t} = \kappa(\frac{\partial^2 T}{\partial r^2} + \frac{1}{r} \frac{\partial T}{\partial r}) \quad (1)$$

where  $T(r, t)$  is the temperature in the sample as a function of distance  $r$  from the axis and time  $t$  and where  $\kappa$  is the thermal diffusivity. The boundary conditions are

$$T(R, t) = b_0 + b_1 \operatorname{Re} \{ \exp(i\omega t) \} \quad (2)$$

$$\frac{\partial T(0, t)}{\partial r} = 0 \quad (3)$$

where  $\omega$  is angular frequency of the temperature wave,  $R$  is the effective radius of the sample, and  $b_0$  and  $b_1$  are constants. The solution of (1) with the boundary conditions (2) and (3) is

$$T(r, t) = b_0 + b_1 \operatorname{Re} \left[ J_0(\sqrt{-i} x) \cdot \exp(i\omega t) / J_0(\sqrt{-i} l) \right] \quad (4)$$

where

$$l = (\omega/\kappa)^{1/2} R \quad (5)$$

$$x = (\omega/\kappa)^{1/2} r$$

At  $r = 0$  and  $r = R$  we have

$$T(0, t) = b_0 + b_1 A \cos(\omega t - \alpha)$$

$$T(R, t) = b_0 + b_1 \cos \omega t$$

where

$$A = [(\operatorname{ber} l)^2 + (\operatorname{bei} l)^2]^{-1/2} \quad (6)$$

$$\alpha = \tan^{-1} (\operatorname{bei} l / \operatorname{ber} l) \quad (7)$$

Thermal diffusivity  $\kappa$  can be determined from either the amplitude ratio  $A$  or the phase lag  $\alpha$ .

#### EXPERIMENTAL DETAILS

Powder samples of  $\text{Mg}_2\text{SiO}_4$  (olivine) were synthesized by sintering an intimate mixture of  $\text{MgO}$  and anhydrous  $\text{SiO}_2$  at  $1700^\circ\text{C}$  and 1 atm for 5 hours. The preparation of an  $\text{Fe}_2\text{SiO}_4$  sample has been described in detail by Akimoto and Fujisawa [1965]. The grain size of the samples, roughly measured by a microscope, was 1 to 5 microns.

The tetrahedral-anvil-type high-pressure apparatus was used here (for detailed description see e.g. Akimoto *et al.* [1965]). A combination of 25-mm-edge tungsten carbide anvils and a 30-mm-edge pyrophyllite tetrahedron was used for  $\text{Mg}_2\text{SiO}_4$  and  $\text{NaCl}$  and 30-mm-edge anvils with a 36-mm-edge tetrahedron for  $\text{Fe}_2\text{SiO}_4$ . The pressure calibration was made at room temperature by utilizing the resistance transitions Bi I-II (26.2 kb), Tl II-III (35.4 kb), and Ba I-II (54.6 kb), according to Jeffrey *et al.* [1966].

The length and the inner diameter of the graphite heater were 10.0 and 3.5 mm for  $\text{Mg}_2\text{SiO}_4$  and  $\text{NaCl}$  and were 12.0 and 3.8 mm for  $\text{Fe}_2\text{SiO}_4$ . The sample-heater assembly was embedded at the center of the pyrophyllite tetrahedron with the axis perpendicular to one of the surfaces of the tetrahedron. Electric current was supplied to the graphite heater through 0.1-mm-thick molybdenum tabs which had a 3.0-mm-diameter hole through which thermocouple leads could be drawn (Figure 1). To generate the sinusoidal temperature wave, a stepwise variation with the period of 1 to 3 sec was superposed on the heating current.

Since higher harmonics were rapidly attenuated, the temperature wave became nearly sinusoidal when it penetrated to a 0.3-mm depth from the surface of the sample. Two chromel-alumel thermocouples, 0.2 mm in diameter, were embedded in the sample: one at the center and the other 0.3 mm from the outer surface. Two lead wires, one from each thermocouple, were connected together to one of the anvils; the other lead wires were drawn out separately through the edge of the tetrahedron and then through the gap of the anvils. No correction was made for the effect of pressure on the emf of the thermocouples.

The temperature variations detected by the thermocouples were recorded on a strip chart from which we measured the amplitude ratio  $A$  and the phase lag  $\alpha$ . Since the amplitude ratio can be measured more accurately than the phase lag, thermal diffusivities were mostly calculated from (5) and (6). In a few cases, thermal diffusivities were also calculated from the phase lag through (5) and (7) and were found to agree with the values from the amplitude ratio within 10%.

In the measurements of  $Mg_2SiO_4$ , the sample was first sintered at a pressure of about 30 kb and a temperature of about 1000°K. When the sintering was completed, the temperature was lowered, the pressure being maintained. The measurements were then taken at that pressure (about 30 kb) while the temperature was being raised to 1000°K and then lowered. After at least two runs were completed, the pressure was raised to about 50 kb, and the measurements were taken in the same way except that the temperature range was extended to about 1400°K. Thus, we measured temperature variations over the range 500° to 1000°K at two different pressures for one sample. After the measurements the sample was inspected for possible distortion. The position of the thermocouples was also checked. The effective radius  $R$  (usually 1.0 to 1.2 mm) was also measured; no correction was made for the change of the radius at high pressures.

A similar procedure was followed for  $Fe_2SiO_4$  and  $NaCl$  though at different pressures and temperatures. For  $NaCl$ , a correction was made for the change of radius due to pressure (4% at 50 kb). In the measurements on  $Fe_2SiO_4$ , we took  $Fe_2SiO_4$  (olivine) as a starting mate-

TABLE 1. Results of Thermal Diffusivity Measurements at High Pressures and Temperatures  
Data of  $Mg_2SiO_4$  are averaged and interpolated at 30 and 50 kb

Material	Pressure, kb	Thermal Diffusivity, $10^{-3}$ cm <sup>2</sup> sec <sup>-1</sup>											Error,* %		
		T = 300°K	T = 400°K	T = 500°K	T = 600°K	T = 700°K	T = 800°K	T = 900°K	T = 1000°K	T = 1100°K	T = 1200°K	T = 1300°K		T = 1400°K	
$Mg_2SiO_4$	30			19.2	16.1	14.2	12.5	11.1	10.3	9.4					±7
$Mg_2SiO_4$	50			25.0	20.8	17.8	15.6	13.7	11.9	11.0	(10.2)†				±7
$NaCl$	29				(28.4)	21.3	16.7	14.3	12.0						±5
$NaCl$	47				(44.0)	29.8	22.5	17.8	14.9	12.7	11.1	10.0	9.1		±7
$Fe_2SiO_4$ (olivine)	48.5	(16.6)	10.8	8.1	6.7	6.0	5.7	5.5							±4
$Fe_2SiO_4$ (spinel)	48.5	(23.9)	15.6	12.5	11.0	(10.2)									±5

\* The range of scatter of the data.  
† Extrapolated values are given in parentheses.

rial. The pressure was first raised to 48.5 kb. Although olivine structure is unstable below 1200°K at this pressure [e.g. *Akimoto et al.*, 1967], it remains metastable below 900°K long enough for the measurements to be made. When the measurements on the metastable  $\text{Fe}_2\text{SiO}_4$  (olivine) were completed, the temperature was set at about 1000°K and maintained for about 1 hour until the olivine-to-spinel reaction was completed. The measurements on  $\text{Fe}_2\text{SiO}_4$  (spinel) were then made. The breakdown of the olivine to spinel was confirmed by the X-ray diffraction method after the sample had been removed. No measurements could be made on  $\text{Fe}_2\text{SiO}_4$  (spinel) at temperatures above 650°K. At such temperatures, electrical conductivity of  $\text{Fe}_2\text{SiO}_4$  (spinel) became very high [Akimoto and Fujisawa, 1965]. As a result, electrical current applied to the graphite heater leaked into the sample and disturbed the measurement.

### RESULTS

Table 1 summarizes the results. The results from a number of runs for many samples are averaged, and the range of the scatter is given. Because the dimension of the sample cannot be measured accurately at high pressures, the absolute values are uncertain to  $\pm 7\%$ . However, the relative change of diffusivity with pressure was measured with the same sample and is relatively reliable.

Figure 2 shows one of the results for  $\text{Mg}_2\text{SiO}_4$ . A linear relation between the reciprocal of thermal diffusivity and temperature is evident.

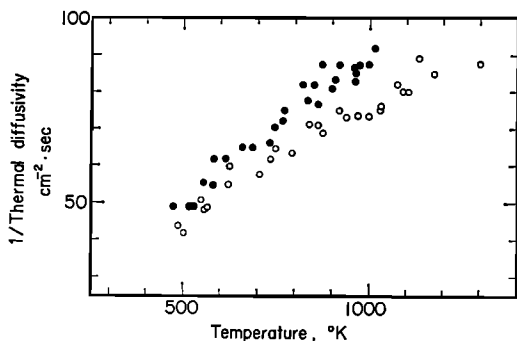

Fig. 2. The reciprocal of thermal diffusivity of  $\text{Mg}_2\text{SiO}_4$  versus temperature. Measurements at the two different pressures are made with the same sample. Solid dots,  $P = 29.5$  kb; open circles,  $P = 47.0$  kb.

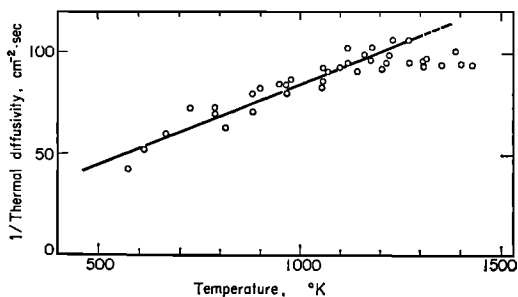

Fig. 3. The reciprocal of thermal diffusivity of  $\text{Mg}_2\text{SiO}_4$  over an extended temperature range up to 1400°K. The straight line is fitted to the data below 1200°K.  $P = 41.5$  kb.

At high temperatures, however, a slight deviation from the linearity is observed, as shown in Figure 3. The result for NaCl is shown in Figure 4, where the linear dependence on temperature is also given. Figure 5 shows the results for  $\text{Fe}_2\text{SiO}_4$ . The curves of the reciprocal of thermal diffusivity are slightly convex upward. About a 50% increase of thermal diffusivity at the olivine  $\rightarrow$  spinel transition is to be noted.

### DISCUSSION AND CONCLUSIONS

Figure 6 shows thermal diffusivities of NaCl (at 700°K) and  $\text{Mg}_2\text{SiO}_4$  (at 700° and 1100°K) as functions of pressure. In Figure 6, zero-pressure values calculated from available data on the thermal conductivity and specific heat are added for comparison with our present results. In these calculations, thermal conductivities  $K$  of NaCl [Birch and Clark, 1940a] and of

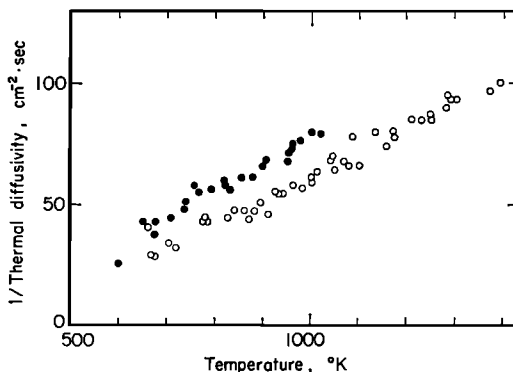

Fig. 4. The reciprocal of thermal diffusivity of NaCl versus temperature at 29.0 (solid dots) and 47.0 kb (open circles).

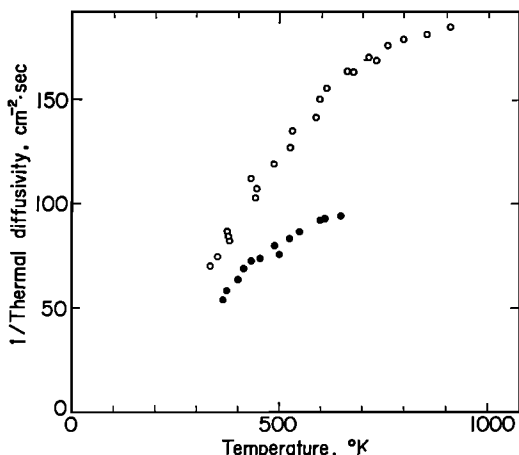

Fig. 5. The effect of olivine-spinel transition of  $Fe_2SiO_4$  on thermal diffusivity.  $P = 48.5$  kb. Open circles, olivine; solid dots, spinel.

$Mg_2SiO_4$  [Kingery *et al.*, 1954] are used; the data of specific heat,  $C$  are from Goranson [1942]:

For NaCl

$K = 0.0048$  cal/cm sec deg,  $C = 0.232$  cal/g deg (at 700°K)

For  $Mg_2SiO_4$

$K = 0.0083$  cal/cm sec deg,  $C = 0.270$  cal/g deg (at 700°K)

$K = 0.0063$  cal/cm sec deg,  $C = 0.302$  cal/g deg (at 1100°K)

Using density values ( $\rho$ ) of 2.16 g/cm<sup>3</sup> for NaCl and 3.20 g/cm<sup>3</sup> for  $Mg_2SiO_4$ , we have from the relation  $\kappa = K/C\rho$

$\kappa = 0.0096$  cm<sup>2</sup>/sec for NaCl (at 700°K)

$\kappa = 0.0096$  cm<sup>2</sup>/sec for  $Mg_2SiO_4$  (at 700°K)

$\kappa = 0.0066$  cm<sup>2</sup>/sec for  $Mg_2SiO_4$  (at 1100°K)

Figure 6 indicates a reasonable relation between the present measurements at high pressures and the values at ambient pressures. The pressure derivatives of thermal diffusivity ( $\partial\kappa/\partial P$ ) are evaluated at  $P = 40$  kb. The results are given in Table 2.

From Figure 6, we can expect a 40% increase of  $\kappa$  for NaCl because of the pressure increase from 0 to 10 kb. Bridgman has found a 36% increase of thermal conductivity of NaCl for the pressure increase from 0 to 10 kb at 30° and 75°C. From the relation  $\kappa = K/C\rho$  the corresponding increase of thermal diffusivity is estimated at 32%, when the increase of density (4% at 10 kb) is taken into account. Our result agrees reasonably well with this value.

From Debye's expression we have

$$\kappa = \frac{1}{3}\bar{l}v_m \quad (8)$$

where  $\bar{l}$  and  $v_m$  are the mean free path and the velocity of phonon. According to Dugdale and MacDonald [1955] and Lawson [1957],

$$\bar{l} = A_0B/C\rho\gamma^2T \quad (9)$$

where  $A_0$ ,  $B$ ,  $C$ ,  $\gamma$ , and  $T$  are the lattice constant, incompressibility, specific heat (per unit mass), Grüneisen's ratio, and temperature, respectively. Equations 8 and 9 can be used to interpret the present results. The values of the parameters in equations 8 and 9 are not, however, accurately known at high pressures and temperatures. We will therefore make only a crude comparison of the pressure dependence of  $\kappa$  measured here with that predicted by equations 8 and 9. Because, among the parameters in equations 8 and 9,  $v_m$  and  $B$  are presumably by far the most pressure-dependent, we have, to the first approximation,

$$\frac{\kappa}{\kappa_0} \sim \left(\frac{B}{B_0}\right) \cdot \left(\frac{v_m}{v_{m0}}\right) \sim \left[1 + \frac{P}{B_0} \left(\frac{dB}{dP}\right)_0\right] \cdot \left[1 + \frac{P}{v_{m0}} \left(\frac{dv_m}{dP}\right)_0\right] \quad (10)$$

where the subscript 0 refers to zero-pressure quantities. For  $Mg_2SiO_4$ , Schreiber and Anderson [1967] reported  $B_0 = 973.6$  kb and  $(dB/dP)_0 = 4.8$ . From their velocity data we have  $v_{m0} = 4.82$  km/sec and  $(dv_m/dP)_0 = 2.52 \times 10^{-2}$  km/sec kb. For NaCl elastic constants have been reported by Bartels and Schuele

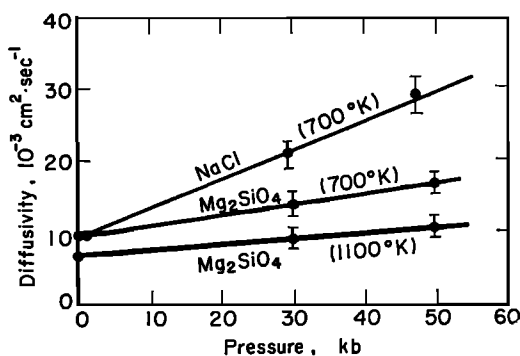

Fig. 6. Thermal diffusivities of NaCl and  $Mg_2SiO_4$  as functions of pressure. High-pressure values are plotted from Table 1, and zero-pressure values are calculated from thermal conductivity.

[1965]. From their data we have  $B_0 = 234$  kb,  $(dB/dP)_0 = 5.35$ ,  $v_{m0} = 2.7$  km/sec, and  $(dv_m/dP)_0 = 1.51 \times 10^{-2}$  km/sec kb. Figure 7 compares  $(\kappa/\kappa_0)$  of NaCl and  $Mg_2SiO_4$  measured here with  $(B/B_0) \cdot (v_m/v_{m0})$  calculated by (10). In view of the gross simplification made in equation 10 and the difference in temperature, we consider the agreement satisfactory.

The deviation from the  $1/\kappa \propto T$  relation for  $Mg_2SiO_4$  at high temperatures may be attributed to radiative heat transfer. Kanamori *et al.* [1968] found a similar behavior for the  $1/\kappa$  versus  $T$  curve for a single-crystal olivine, though at a considerably lower temperature, 700°K. It was suggested that if the photon mean free path is about 2 mm in the olivine, the behavior can be attributed to radiative heat transfer. If we apply the same argument to the present data, we can estimate the photon mean free path. From the difference between the measured value of  $1/\kappa$  and the straight line fitted to the lower temperature data (Figure 3) we estimate the radiative contribution  $K_r$  at 1400°K as 0.0017 cal/cm sec deg. Using the relation  $K_r = 16 n^2 \sigma T^3/3\epsilon$  ( $n$ , refractive index;  $\sigma$ , Stefan-Boltzmann constant;  $\epsilon$ , gray opacity) [Clark, 1957], we have the mean free path  $\epsilon^{-1} \sim 0.3$  mm. This value is one order of magnitude smaller than the value found by Kanamori *et al.* [1968]. This difference may be qualitatively explained in terms of the difference of the samples; flawless single crystals were used by Kanamori *et al.*, whereas ceramic-like polycrystals were used here. For the single crystals the mean free path is governed essentially by the intrinsic optical property of the crystal (for the optical property of the olivine, see Fukao *et al.* [1968]), whereas for the polycrystals the grain boundaries limit the mean free path. Hence, in the discussion of radiative heat transfer in minerals and rocks, the grain

TABLE 2. Pressure Derivative of Thermal Diffusivity at  $P = 40$  kb

Material	$T$ , °K	$\partial\kappa/\partial P$ , $\text{cm}^2 \text{sec}^{-1} \text{kb}^{-1}$
NaCl	700	$4.7 \times 10^{-4}$
$Mg_2SiO_4$	700	$1.8 \times 10^{-4}$
$Mg_2SiO_4$	1100	$0.8 \times 10^{-4}$

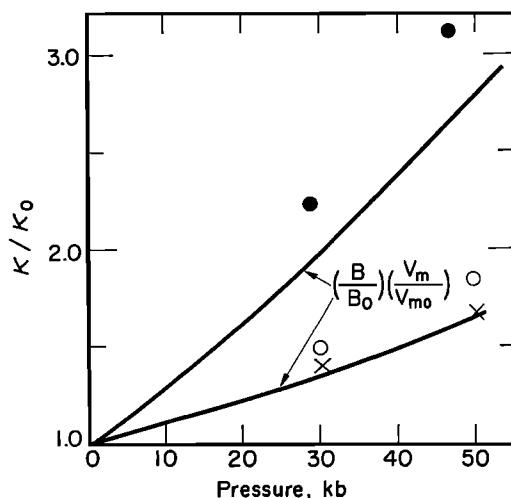

Fig. 7. Relative change of thermal diffusivity with pressure as compared with values predicted by elastic constants ( $B$ , incompressibility;  $V_m$ , phonon velocity). Solid dots, NaCl at 700°K; open circles,  $Mg_2SiO_4$  at 700°K; crosses,  $Mg_2SiO_4$  at 1100°K.

size and the intrinsic optical property are important.

*Acknowledgment.* A part of the present study was performed with the aid of the tetrahedral press of the Government Industrial Research Institute, Nagoya. We would like to thank the members of the high-pressure laboratory of the institute for their courtesy.

#### REFERENCES

- Akimoto, S., and H. Fujisawa, Demonstration of the electrical conductivity jump produced by the olivine-spinel transition, *J. Geophys. Res.*, **70**, 443-450, 1965.
- Akimoto, S., H. Fujisawa, and T. Katsura, The olivine-spinel transition in  $Fe_2SiO_4$  and  $Ni_2SiO_4$ , *J. Geophys. Res.*, **70**, 1969-1977, 1965.
- Akimoto, S., E. Komada, and I. Kushiro, Effect of pressure on the melting of olivine and spinel polymorph of  $Fe_2SiO_4$ , *J. Geophys. Res.*, **72**, 679-686, 1967.
- Bartels, R. A., and D. E. Schuele, Pressure derivatives of the elastic constants of NaCl and KCl at 295°K and 195°K, *J. Phys. Chem. Solids*, **26**, 537-549, 1965.
- Birch, F., and H. Clark, The thermal conductivity of rocks and its dependence upon temperature and composition, *Am. J. Sci.*, **238**, 529-558, 1940a.
- Birch, F., and H. Clark, The thermal conductivity of rocks and its dependence upon temperature and composition, **2**, *Am. J. Sci.*, **238**, 613-635, 1940b.

- Bridgman, P. W., Thermal conductivity and compressibility of several rocks under high pressures, *Am. J. Sci., Ser. 5*, 7, 81-102, 1924.
- Carslaw, H. S., and J. C. Jaeger, *Conduction of Heat in Solids*, 2nd ed., pp. 1-161, Oxford University Press, New York, 1959.
- Clark, H., The effects of simple compression and wetting on the thermal conductivity of rocks, *Trans. Am. Geophys. Union*, 22, 543-544, 1941.
- Clark, S. P., Radiative transfer in the earth's mantle, *Trans. Am. Geophys. Union*, 38, 931-938, 1957.
- Dugdale, J. S., and D. K. C. MacDonald, Lattice thermal conductivity, *Phys. Rev.*, 98, 1751-1752, 1955.
- Fukao, Y., H. Mizutani, and S. Uyeda, Optical absorption spectra at high temperatures and radiative thermal conductivity of olivines, *Phys. Earth Planetary Interiors*, 1, 57-62, 1968.
- Goranson, R. W., Heat capacity, heat of fusion, in *Handbook of Physical Constants*, edited by F. Birch, J. F. Schairer, and H. C. Spicer, pp. 223-242, Geological Society of America, New York, 1942.
- Hughes, D. S., and F. Sawin, Thermal conductivity of dielectric solids at high pressure, *Phys. Rev.*, 161, 861-863, 1967.
- Jeffrey, R. N., J. D. Barnett, H. B. Vanfleet, and H. T. Hall, Pressure calibration to 100 kb based on the compression of NaCl, *J. Appl. Phys.*, 37, 3172-3180, 1966.
- Kanamori, H., N. Fujii, and H. Mizutani, Thermal diffusivity measurement of rock-forming minerals from 400° to 1100°K, *J. Geophys. Res.*, 73, 595-605, 1968.
- Kawada, K., Studies of the thermal state of the earth, The 15th paper: Variation of thermal conductivity of rocks, 1, *Bull. Earthquake Res. Inst. Tokyo Univ.*, 42, 631-647, 1964.
- Kawada, K., Studies of the thermal state of the earth, The 17th paper: Variation of thermal conductivity of rocks, 2, *Bull. Earthquake Res. Inst. Tokyo Univ.*, 44, 1071-1091, 1966.
- Kingery, W. D., The thermal conductivity of ceramic dielectrics, in *Progress in Ceramic Science*, vol. 2, edited by J. E. Burke, pp. 182-235, Pergamon, New York, 1962.
- Kingery, W. D., J. Francl, R. L. Coble, and T. Vasilos, Thermal conductivity, 10, Data for several pure oxide metals corrected to zero porosity, *J. Am. Ceram. Soc.*, 37, 107-111, 1954.
- Lawson, A. W., On the high temperature heat conductivity of insulators, *J. Phys. Chem. Solids*, 3, 154-155, 1957.
- Schreiber, E., and O. L. Anderson, Pressure derivatives of the sound velocities of polycrystalline forsterite, with 6% porosity, *J. Geophys. Res.*, 72, 762-764, 1967.
- Walsh, J. B., and E. R. Decker, Effect of pressure and saturating fluid on the thermal conductivity of compact rock, *J. Geophys. Res.*, 71, 3053-3061, 1966.

(Received March 25, 1968.)