Thermal Energy Storage for Power Generation

**M. K. Drost
Z. I. Antoniak
D. R. Brown
K. Sathyanarayana**

October 1989

**Prepared for the U.S. Department of Energy
under Contract DE-AC06-76RLO 1830**

**Pacific Northwest Laboratory
Operated for the U.S. Department of Energy
by Battelle Memorial Institute**



DISCLAIMER

This program was prepared as an account of work sponsored by an agency of the United States Government. Neither the United States Government nor any agency thereof, nor Battelle Memorial Institute, nor any of their employees, makes any warranty, expressed or implied, or assumes any legal liability or responsibility for the accuracy, completeness, or usefulness of any information, apparatus, product, or process disclosed, or represents that its use would not infringe privately owned rights. Reference herein to any specific commercial product, process, or service by trade name, trademark, manufacturer, or otherwise, does not necessarily constitute or imply its endorsement, recommendation, or favoring by the United States Government of any agency thereof, or Battelle Memorial Institute. The views and opinions of authors expressed herein do not necessarily state or reflect those of the United States Government or any agency thereof.

PACIFIC NORTHWEST LABORATORY
operated by
BATTELLE MEMORIAL INSTITUTE
for the
UNITED STATES DEPARTMENT OF ENERGY
under Contract DE-AC06-76RLO 1830

Printed in the United States of America

Available to DOE and DOE contractors from the
Office of Scientific and Technical Information, P.O. Box 62, Oak Ridge, TN 37831;
prices available from (615) 576-8401. FTS 626-8401.

Available to the public from the National Technical Information Service,
U.S. Department of Commerce, 5285 Port Royal Rd., Springfield, VA 22161.

NTIS Price Codes, Microfiche A01

Printed Copy

<u>Pages</u>	<u>Price Codes</u>
001-025	A02
026-050	A03
051-075	A04
076-100	A05
101-125	A06
126-150	A07
151-175	A08
176-200	A09
201-225	A10
226-250	A11
251-275	A12
276-300	A13

THERMAL ENERGY STORAGE
FOR POWER GENERATION

M. K. Drost
Z. I. Antoniak
D. R. Brown
K. Sathyanarayana

October 1989

Prepared for
the U.S. Department of Energy
under Contract DE-AC06-76RLO 1830

Pacific Northwest Laboratory
Richland, Washington 99352



SUMMARY

Studies strongly indicate that the United States will face widespread electrical power constraints in the 1990s, with most regions of the country experiencing capacity shortages by the year 2000. In many cases, the demand for increased power will occur during intermediate and peak demand periods. Much of this demand is expected to be met by oil- and natural gas-fired Brayton cycle turbines and combined-cycle plants. While natural gas is currently plentiful and reasonably priced, the availability of an economical long-term coal-fired option for peak and intermediate load power generation will give electric power utilities an option in case either the availability or cost of natural gas should deteriorate.

A number of demand-side and system-wide storage options for intermediate and peak power capacity exist but, when new generation is unavoidable, the only mature non-petroleum option is a cycling coal-fired power plant. The Pacific Northwest Laboratory^(a) conducted a preliminary evaluation of an alternative method of using coal to generate peak and intermediate load power.

The alternative method uses a continuously operating coal-fired heater to heat molten nitrate salt, which is then stored. During peak demand periods, this heated molten salt is used as a heat source for a conventional Rankine cycle steam power plant. This allows the coal-fired salt heater to be much smaller than the size of a coal-fired boiler in a conventional cycling coal-fired power plant. The general impact of the concept is to decouple the generation of thermal energy from its conversion to electricity.

Conceptual designs were developed for a number of operating schedules. The conceptual designs had sufficient detail to allow development of capital and levelized energy cost estimates. The resulting costs were then compared to a base case consisting of a conventional cycling pulverized coal-fired power plant. The technical feasibility of molten nitrate salt thermal energy storage was investigated by conducting a literature review and contacting researchers working with the technology.

(a) Operated by Battelle Memorial Institute for the U.S. Department of Energy under Contract DE-AC06-76RLO 1830.

Costs were estimated for six power plant operating schedules. Levelized energy cost estimates were prepared for each operating schedule for one conventional and two coal/thermal energy storage plants, which represent different assumptions for plant construction periods. The evaluations show the coal/thermal energy storage plant to have a lower levelized energy cost than the corresponding cycling coal plant for all plant operating schedules evaluated. This concept looks most attractive at lower plant capacity factors (fewer operating hours) where the size of the coal-firing equipment is most strongly reduced and, hence, the benefits of incorporating thermal energy storage are the greatest. However, substantial uncertainties exist in several key inputs to the levelized energy costs.

The use of molten nitrate salt in coal-fired power plants may improve the potential for modular construction. In addition, the use of thermal energy storage with advanced coal combustion technologies, such as a coal gasification combined-cycle plant and fluidized bed combustion, improves the flexibility of these technologies by increasing their peak and intermediate load power.

While not currently used in power production, molten nitrate salt thermal energy storage has been extensively investigated as part of the U.S. Department of Energy's Solar Thermal Program. The concept has been the subject of bench-scale experimental investigations, several detailed design studies, and small-scale field demonstrations. While significant problems remain, the balance of opinion is that commercialization of molten nitrate salt thermal energy storage is technically feasible.

Recommendations are given for the areas most in need of technology development.

CONTENTS

SUMMARY	iii
1.0 INTRODUCTION	1.1
1.1 STUDY OBJECTIVES	1.1
1.2 ORGANIZATION OF REPORT	1.2
2.0 BACKGROUND	2.1
2.1 CONCEPT DESCRIPTION	2.1
2.2 RESULTS OF PREVIOUS EVALUATIONS	2.2
3.0 METHODOLOGY	3.1
3.1 SELECTION OF PLANT OPERATING SCHEDULES	3.1
3.2 CONCEPTUAL DESIGN	3.2
3.3 ECONOMIC EVALUATION	3.3
3.4 TECHNICAL FEASIBILITY	3.5
4.0 CONCEPTUAL DESIGN	4.1
4.1 COAL-FIRED SALT HEATER SUBSYSTEM	4.1
4.1.1 Molten Salt Coal-Fired Furnace Design Features	4.2
4.1.2 Analysis	4.3
4.2 SALT TRANSPORT SUBSYSTEM	4.10
4.3 SALT STORAGE SUBSYSTEM	4.10
4.3.1 Design Options	4.10
4.3.2 Proposed Design	4.11
4.4 STEAM GENERATOR SUBSYSTEM	4.12
4.4.1 Description	4.12
4.4.2 Proposed Design	4.12
4.5 BALANCE-OF-PLANT	4.14

4.6	PERFORMANCE EVALUATION	4.14
5.0	ECONOMIC EVALUATION	5.1
5.1	GROUND RULES AND ASSUMPTIONS	5.1
5.2	CAPITAL COST ESTIMATES	5.2
5.2.1	Conventional Power Plant Component Costs	5.3
5.2.2	Molten Salt Component Costs	5.9
5.3	OPERATING AND MAINTENANCE COSTS	5.12
5.3.1	Fuel Costs	5.12
5.3.2	Conventional Plant Non-Fuel Operating and Maintenance Costs	5.13
5.3.3	Molten Salt Component Non-Fuel Operating and Maintenance Costs	5.15
5.4	LEVELIZED ENERGY COST ESTIMATES	5.15
6.0	OTHER CHARACTERISTICS OF UTILITY THERMAL ENERGY STORAGE	6.1
6.1	POTENTIAL FOR MODULAR CONSTRUCTION	6.1
6.2	POTENTIAL FOR FLEXIBLE OPERATION	6.3
6.3	POTENTIAL FOR APPLICATION WITH CLEAN COAL TECHNOLOGY	6.3
6.4	MOLTEN SALT THERMAL ENERGY STORAGE TECHNOLOGY DEVELOPMENTS	6.5
6.5	SALT HANDLING ISSUES	6.6
7.0	CONCLUSIONS AND RECOMMENDATIONS	7.1
7.1	CONCLUSIONS	7.1
7.2	RESEARCH NEEDS	7.1
8.0	REFERENCES	8.1
	APPENDIX - FEASIBILITY AND TECHNICAL STATUS OF USING MOLTEN NITRATE SALT FOR ENERGY STORAGE	A.1

FIGURES

2.1c	Coal-Fired Peaking Power Plant Using Thermal Energy Storage	2.2
6.1c	Arrangement of a Modular Coal-Fired Power Plant Using Key Levelized Molten Salt Thermal Energy Storage	6.2
6.2a	Arrangement of a Coal Gasification Combined Cycle Power Plant with Molten Salt Thermal Energy Storage	6.5
A.1	Subsystem Research Experiment Flow Schematic	A.5
A.2	Subsystem Research Experiment Hot and Cold Tanks	A.6
A.4	Plant Availability	A.4
5.1	Financial Assumptions	5.1
5.2	United Engineers & Constructors Study Coal Plant Costs	5.2
5.3	Total Direct Construction Costs, 500 MWe Power Plant	5.3
5.4	Startup, Land, and Working Capital Costs	5.4
5.5	Economy-of-Scale Factor Cost Data	5.5
5.6	Direct Construction Cost Estimating Equations	5.6
5.7	Molten Salt Transport Costs	5.7
5.8	Power Plant Configurations	5.8
5.9	Levelized Energy Cost Results	5.9
5.10	Summary Cost and Performance Comparison (Conventional Coal Versus CoALTES)	5.10
A.1	Storage Tank Heat Losses	A.1

TABLES

3.1	Plant Operating Schedules	3.1
3.2	Key Levelized Energy Cost Inputs	3.4
4.1	Typical Convective Heat Transfer Coefficients for Water and Molten Salt	4.4
4.2	Steam Boiler Versus Salt Heater	4.9
4.3	Heat Exchanger Specifications	4.13
4.4	Plant Availability	4.16
5.1	Financial Assumptions	5.2
5.2	United Engineers & Constructors Study Coal Plant Costs	5.4
5.3	Total Direct Construction Costs, 500 MWe Power Plant	5.6
5.4	Startup, Land, and Working Capital Costs	5.7
5.5	Economy-of-Scale Factor Cost Data	5.8
5.6	Direct Construction Cost Estimating Equations	5.9
5.7	Molten Salt Transport Costs	5.10
5.8	Power Plant Configurations	5.16
5.9	Levelized Energy Cost Results	5.16
5.10	Summary Cost and Performance Comparison: Conventional Coal Versus Coal/TES	5.17
A.1	Storage Tank Heat Losses	A.8

THERMAL ENERGY STORAGE FOR POWER GENERATION

1.0 INTRODUCTION

Studies give increasingly strong indications that the United States will face widespread electrical power generating capacity constraints in the 1990s, with most regions of the country experiencing capacity shortages by the year 2000. In many cases, the demand for increased power will occur during intermediate and peak demand periods (United States Energy Association 1988). Much of this demand is expected to be met by oil- and natural gas-fired Brayton cycle turbines and combined-cycle plants. While natural gas is currently plentiful and reasonably priced, the availability of an economical long-term coal-fired option for peak and intermediate load power generation will give electric power utilities an option in case either the availability or cost of natural gas should deteriorate.

A number of demand-side and system-wide energy storage options for intermediate and peak capacity exist but, when new generating capacity is unavoidable, the only mature non-petroleum option currently available in the U.S. is cycling coal-fired power plants. This study was conducted by Pacific Northwest Laboratory^(a) (PNL) to make an evaluation of an alternative method of using coal to generate peak and intermediate load power. The approach, documented in this report, uses a continuously operating, coal-fired heater to heat molten nitrate salt, which is then stored. During peak demand periods, the hot salt is used as a heat source for a conventional Rankine cycle steam power plant.

1.1 STUDY OBJECTIVES

This study had the primary goal of assessing the technical and economic feasibility of using molten salt thermal energy storage (TES) in a coal-fired power plant. The specific objectives were:

- to develop a conceptual design of a pulverized coal-fired power plant using molten salt storage

(a) Operated by Battelle Memorial Institute for the U.S. Department of Energy under Contract DE-AC06-76RLO 1830.

- to develop a capital cost and levelized energy cost estimate for the conceptual design
- to determine the technical feasibility of molten salt storage
- to develop concepts for integrating molten salt storage with advanced coal combustion technologies.

1.2 ORGANIZATION OF REPORT

The background of the study is presented in Section 2 while the method of analysis is discussed in Section 3. Section 4 describes the development of the conceptual design (objective 1). Section 5 presents the capital and levelized cost estimates for the conceptual design (objective 2). Other characteristics of the concept and approaches for integrating TES with advanced coal combustion technologies are presented in Section 6 (objective 4) while conclusions are discussed in Section 7. The technical feasibility of the concept (objective 3) is discussed in the Appendix.

2.0 BACKGROUND

This study primarily focussed on evaluating applications of molten nitrate salt TES with conventional pulverized coal-firing technology. Section 2.1 presents a description of the concept while Section 2.2 discusses the results and relevance of previous investigations of the subject.

2.1 CONCEPT DESCRIPTION

Thermal energy storage can be integrated with conventional and advanced coal technologies in a number of ways. This study was focussed on using conventional pulverized coal combustion technology. Alternative arrangements, using advanced coal technologies, are briefly described in Section 6.

The concept evaluated in this study uses a pulverized coal-fired salt heater to heat molten nitrate salt from 280°C (536°F) to 566°C (1050°F). The hot molten salt is returned to a hot salt tank for storage. During peak demand periods, hot salt is withdrawn from the hot salt tank and used as a heat source for a steam generator. The molten salt is then returned to the cold molten salt storage tank. The steam generator produces steam for a conventional steam cycle. Turbine inlet steam conditions are 538°C (1000°F) and 16,500 kPa (2400 psi). The concept is shown in Figure 2.1.

The coal-fired salt heater operates continuously, charging storage. The steam generator and turbine only operate when electric power is being generated. This allows the salt heater to be much smaller than the size of a coal-fired boiler in a conventional cycling coal-fired power plant. In addition, the salt heater would not be cycled, avoiding the difficulties associated with cycling a coal-fired boiler. The general impact of the concept is to decouple (on a temporal basis) the generation of thermal energy and its conversion to electricity.

The storage medium is a mixture of sodium nitrate (60 wt%) and potassium nitrate (40 wt%). Thermal energy is stored as sensible heat in this molten salt. This salt mixture freezes at a temperature near 240°C (464°F).

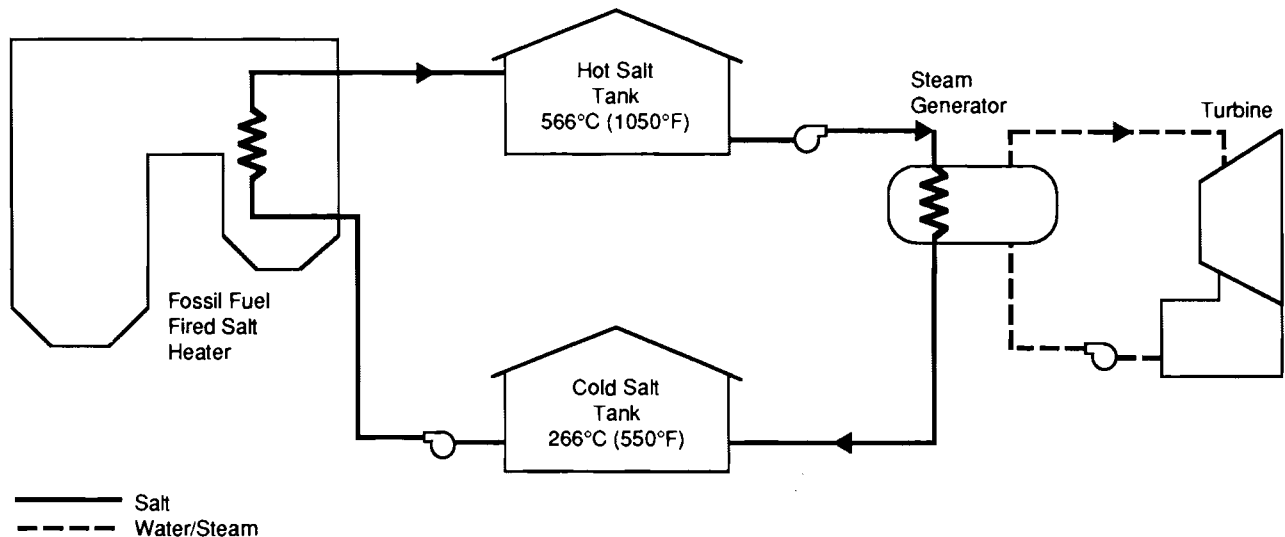

FIGURE 2.1. Coal-Fired Peaking Power Plant Using Thermal Energy Storage

Consequently precautions must be taken to ensure that the temperature of the molten salt never drops below the freezing point. The maximum salt temperature is 566°C (1050°F) and is determined by the chemical stability of the salt.

While not used to produce power commercially, nitrate salt TES was extensively investigated as part of the U.S. Department of Energy's (DOE) Solar Thermal Program. The concept was the subject of bench-scale experimental investigations, several detailed design studies, and small-scale field demonstrations. While significant problems remain, the general technical opinion of experts is that commercialization of molten nitrate salt TES is technically feasible.

2.2 RESULTS OF PREVIOUS EVALUATIONS

A series of studies on thermal energy storage for near-term utility applications was conducted by DOE, the Electric Power Research Institute (EPRI), and the National Aeronautics and Space Administration (NASA) in the late 1970s (General Electric 1979a,b,c). The results of these studies were not favorable

for thermal storage. The studies screened a large number of TES systems that could be coupled with an 800-MWe coal or a 1140-MWe light water nuclear reactor. These studies were limited to TES concepts that did not require any modifications to the coal-fired or nuclear steam generators.

Molten nitrate salt TES was included as one thermal storage option in these studies. The concept used the exhaust of the high-pressure turbine for charging storage. During peak demand periods, heat was extracted from storage and used to generate steam for a separate low-pressure turbine. The high-pressure turbine exhaust steam was at a temperature of 300°C (572°F). The maximum storage temperature was approximately 280°C (536°F). During discharge, low-pressure steam was generated at 251°C (484°F) for peak power production. The decision to use high-pressure turbine exhaust for charging storage had several negative impacts on nitrate salt TES. First, nitrate salts have a higher maximum temperature [450°C to 566°C (842°F to 1050°F) depending on the salt mixture] than other thermal storage media, such as heat transfer oils, but they often are more expensive. By operating storage at 280°C (536°F), the benefits of the molten salt were not attained; the small change in molten salt temperature between charge and discharge conditions meant that a very large molten salt inventory was required to provide the desired storage. Second, the low temperature of the steam produced during discharge resulted in low steam cycle efficiency when operating from storage. In addition, extra thermal energy had to be stored to compensate for the poor efficiency of the discharge steam cycle, further increasing the size of the storage system. The overall result was that the nitrate salt TES option had an excessively high capital cost and poor performance. These results apparently discouraged further studies of the use of molten salt TES for power generation.

In the last 10 years, significant changes have decisively altered the situation. These include:

- improved plant integration - The decision in the early studies to concentrate on TES concepts that do not modify the steam generator is understandable given the emphasis on near-term applications, but this ground rule had a serious negative impact on nitrate salt TES. Alternate methods for integrating storage have been developed that avoid the difficulties associated with using high-pressure turbine exhaust for charging storage.

The concept described in Section 2.1 uses direct heating of salt to 566°C (1050°F) in a coal-fired salt heater. During discharge, steam is generated at conditions typical of modern coal-fired power plants resulting in no performance penalty when operating from storage. Improved plant integration results in reduced capital cost due to the increased temperature difference between the hot and cold salt and superior performance due to the improved steam conditions.

- improved storage systems - The earlier studies were based on first-generation TES concepts. During the last 10 years, substantial progress was made on TES design, particularly nitrate salt systems. The DOE Solar Thermal Program funded the development and field testing of low-cost nitrate salt TES. In general, nitrate salt has proved to be economical and reliable. The concept exceeded all cost goals; current estimates predict energy-related costs of \$15/kWh (Williams et al. 1987) in 1986 dollars. The comparable cost estimate from the earlier studies is approximately \$90/kWh in 1986 dollars. The cost reduction is due to use of lower-cost nitrate salts and improved energy storage density by increasing the temperature difference between the hot and cold salt.
- advanced coal combustion technologies - A number of new coal combustion technologies are being developed, and several are near commercialization, e.g., integrated coal gasification combined-cycle power plants and fluidized bed combustion. These technologies offer new opportunities for integrating TES, which is particularly important because several advanced coal combustion technologies result in power plants that are difficult to cycle or operate at part load.

These three developments indicated that utility applications for TES should be re-evaluated and that the potential exists for TES technology to make a substantial contribution toward lowering electrical generation costs and providing new peak generation capabilities.

3.0 METHODOLOGY

The use of molten salt TES in a coal-fired power plant was evaluated by developing conceptual designs for a number of operating schedules. The conceptual designs had sufficient detail to allow development of preliminary capital and levelized energy cost estimates. The resulting costs were then compared to the costs for a base case conventional cycling pulverized coal-fired power plant. The technical feasibility of molten salt TES was investigated by conducting a literature review and contacting researchers working with the technology.

3.1 SELECTION OF PLANT OPERATING SCHEDULES

The general approach used in this study consisted of developing a conceptual design and cost estimate for the coal-fired plant with TES and comparing this data to the costs for a conventional cycling pulverized coal-fired plant operated during peak and intermediate demand periods. The comparison was made for a range of plant operating schedules. Table 3.1 summarizes the assumed operating schedules and gives several key design features of the thermal storage concept required to meet these schedules.

TABLE 3.1. Plant Operating Schedules

<u>Days of Operation per Week</u>	<u>Hours of Operation per Day</u>	<u>Approximate Capacity Factor, %</u>	<u>Approximate Size of Storage, MWht</u>	<u>Equivalent Size of Coal Firing Equipment for TES System, MWe</u>
5	8	20	6,763	167
5	12	30	7,591	250
5	16	40	6,741	330
7	6	20	5,698	125
7	9	30	7,139	188
7	12	40	7,591	250

The range of operating schedules was selected to include nominal capacity factors ranging from 20% to 40%. Two weekly operating schedules were evaluated. In the first case, the plant was assumed to operate for 5 days per week. The second case involved operation for 7 days per week with a shorter daily operating period.

In all cases, the peak plant net output was assumed to be 500 MWe for both the conventional plant and the coal-fired plant with TES. This resulted in all plant configurations having a similar steam cycle, steam turbine, and switch gear. The significant design variations occurred in the coal-handling and coal-firing equipment. As the capacity factor decreases, the size and cost of the coal-handling and coal-firing equipment in the TES option will decrease. The size and cost of the TES subsystem will increase. The size and cost of the coal-firing equipment in the conventional design will not vary with capacity factor.

3.2 CONCEPTUAL DESIGN

The main element of this study was the development of a conceptual design of a coal-fired power plant with TES. The conceptual design process served two purposes. First, the design was detailed sufficiently to allow the development of preliminary capital and levelized cost estimates. In addition, the design process identified problems that might impact the technical feasibility of the concept.

The goal of the conceptual design was to characterize the size and performance of a coal-fired power plant with TES and then compare it to a conventional cycling coal-fired power plant. In many cases, the conventional plant and the plant using TES will have similar equipment. Examples include the turbine/generator and the switchyard. Other components, such as the coal handling, flue gas desulfurization, and ash handling equipment, were assumed to have a similar design, but were downsized for the plant with TES. The design study concentrated on subsystems impacted by the addition of molten salt TES. These include the coal-fired salt heater, salt transport piping, salt storage, and salt-heated steam generators.

The approach used to characterize a subsystem depended on the subsystem and the availability of reliable design information. The approaches used for the major plant subsystems are summarized below.

- coal-fired salt heater subsystem - The coal-fired salt heater is a new component and design data were not available. The component was characterized by using data developed for molten salt heating solar central receivers and conventional coal-fired steam generators to size major heat exchanger surfaces. The coal handling equipment, combustion air handling equipment, flue gas handling equipment, pollution control equipment, and structural design were assumed to be similar to that in a conventional coal-fired power plant except for size.
- molten salt TES and steam generator subsystems - The molten salt TES and steam generator subsystems were characterized by using design information developed as part of several design studies conducted for the U.S. Department of Energy's Solar Central Receiver Program.
- power generation subsystem - The energy conversion subsystem consisted of the steam Rankine cycle, steam turbine, and generator. The energy conversion subsystem for the coal-fired power plant with TES was identical to the power generation subsystem used in a conventional cycling coal-fired power plant and was not characterized as part of this study.

The performance of the major subsystems was also characterized. In some cases, performance estimates were based on previous design studies.

3.3 ECONOMIC EVALUATION

The economic evaluation was conducted by calculating and comparing the levelized energy cost (LEC) of a conventional coal-fired power plant to a coal-fired power plant with molten salt TES. Levelized cost analysis combines initial cost, annually recurring cost, and system performance characteristics with financial parameters to produce a single figure-of-merit (the LEC) that is economically correct and can be used to compare the projected energy costs of alternative power plant concepts. The specific economic methodology employed was that defined in Brown et al. (1987). Some of the key inputs to the LEC analysis conducted for this study are identified in Table 3.2. A generalized discussion of the estimating approach follows; information regarding the specific estimating approach and economic assumptions is presented in Section 5.

TABLE 3.2. Key Levelized Energy Cost Inputs

Initial Costs	
Coal-handling equipment	Boiler
Emissions-handling equipment	Turbine/generator
Salt heater	Salt storage
Salt steam generator	Salt piping
Balance of plant	Land
Working capital	Startup
Recurring Costs	
Fixed operation and maintenance	Variable operation and maintenance
Consumables	Fuel
Design and Performance Factors	
Power generation capacity	Coal-firing capacity
Molten salt storage capacity	Annual plant availability
Annual plant heat rate	Generation schedule

Initial capital costs were first identified in the literature for a conventional 500 MWe coal-fired power plant at a relatively detailed level. For example, the turbine plant cost was distributed into costs such as those for turbine generator, condensing system, feed heating system, instrumentation and control, and other turbine plant equipment. Each individual cost element for the entire plant was divided into two element categories: variable elements (those related to the coal-firing capacity) and fixed elements (those related to the power-generation capacity). Some elements were split into both fixed and variable parts. The capacity and cost of the variable elements depend on the plant's designed power generation schedule and are lower for the coal-fired power plant with molten salt TES than for the conventional coal plant. The capacity and cost of the fixed elements are the same for both coal-fired power plants with molten salt TES and conventional coal plants.

Individual cost elements were then assigned to coal-handling, boiler, emissions-handling, power generation, and balance-of-plant (BOP) components.

Equations estimating the cost of each of these components as a function of power-generation or coal-firing capacity were derived from power plant economy-of-scale studies described in the literature.

Molten salt storage and steam generator costs were obtained from research reports on solar thermal power systems. Molten salt heater costs were scaled from conventional boiler costs based on their different heat transfer tubing designs. Finally, molten salt piping designs and cost estimates were prepared by PNL.

Estimates for fixed, variable, and consumable operation and maintenance (O&M) elements were developed in a manner similar to the initial capital costs, i.e., O&M cost elements were separated into coal-firing-related and power-generation-related parts and estimating equations for each part were developed as a function of plant power rating. Current and future coal cost estimates were derived from projections made from several energy forecasting organizations.

As mentioned above, the economic methodology employed was that defined in Brown et al. (1987). Economic assumptions for factors such as the discount rate, income tax rate, and plant life, were primarily based on assumptions specified in the Electric Power Research Institute's (EPRI) Technical Assessment Guide (1986a) for the utility industry. These assumptions are specifically identified in Section 5.

3.4 TECHNICAL FEASIBILITY

The combining of coal and salt technologies depends on the availability of technically feasible thermal storage. The technical status of nitrate salt storage was specifically investigated to determine if this approach to thermal energy storage could reasonably be expected to be commercially available in the middle to late 1990s. Nitrate salt storage has received considerable attention by the solar community because it has the potential for cost-effective storage for solar thermal power plants. This has resulted in a substantial number of studies, including an on-going technology development program at Sandia National Laboratories. The technical status of nitrate

salt storage was evaluated by reviewing the pertinent literature and contacting knowledgeable staff at other national laboratories. The results of these evaluations are presented in the Appendix.

4.0 CONCEPTUAL DESIGN

The conceptual design characterized a coal-fired power plant with TES in sufficient detail to allow the development of a meaningful cost estimate. This section presents the results of the conceptual design by subsystem. Section 4.1 describes the coal-fired salt heater. The salt transport system is described in Section 4.2. The salt storage subsystem is presented in Section 4.3, and the salt-heated steam generators are presented in Section 4.4. The balance-of-plant is described in Section 4.5 while performance calculations are presented in Section 4.6.

4.1 COAL-FIRED SALT HEATER SUBSYSTEM

The technology to produce large conventional pulverized coal-fired boilers is mature; high efficiency, good reliability in base load applications, and reasonable cost have been achieved. These attributes are the result of long-term research and development efforts and a large experience base from years of boiler use in utility applications. A coal-fired salt heater will have many features in common with a coal-fired boiler but a significant research program will be required to bring coal-fired salt heating technology to the same level of development as coal-fired steam generation.

In large conventional boilers, the coal is generally pulverized, mixed with combustion air, and blown into the furnace where the pulverized coal is combusted. The furnace walls (also called water walls) that enclose the combustion process consist of metal tubes or tubes separated by fins. In the lower radiant zone of the furnace, radiation heat transfer from the combustion process to the wall is the dominant heat transfer mechanism. The buildup of molten coal ash (slag) will reduce the heat transfer from $552,000 \text{ W/m}^2$ ($175,000 \text{ Btu/ft}^2\text{-h}$) to $158,000 \text{ W/m}^2$ ($50,000 \text{ Btu/ft}^2\text{-h}$) (Babcock and Wilcox 1978), where surface area is based on the projected surface area of the furnace walls. High-temperature flue gas leaves the radiant zone of the furnace and then passes through the convective zone where heat is transferred to heat exchanger tubes extending from the furnace walls. In this region of the boiler, both convection and radiation heat transfer are important but the

combined flue gas-side heat transfer coefficient seldom exceeds $170 \text{ W}/(\text{m}^2\text{-K})$ [$30 \text{ Btu}/(\text{ft}^2\text{-h-F})$] (Babcock and Wilcox 1978). The convective heat transfer inside the water-wall tubes is predominantly boiling heat transfer and the resistance to heat transfer can be largely ignored in furnace design (Babcock and Wilcox 1978). However, scale deposits from minerals in the boiler water can result in a significant resistance to heat transfer, and must be prevented. In the convective zones the flue gas typically is used to superheat or reheat steam. Heat transfer to steam is much less effective than to liquid water so the tube side convective heat transfer resistance must be included when the superheaters and reheaters are being analyzed.

4.1.1 Molten Salt Coal-Fired Furnace Design Features

Although the relevant molten salt thermal-hydraulic properties are not radically different from water (Martin Marietta 1984), a new furnace design is required because the molten salt does not undergo a phase change such as water/steam experiences. The molten salt remains a single-phase fluid throughout the heat transfer process. This results in good heat transfer throughout all zones of the salt heater and avoids the high pressures encountered in steam generation. Because high pressures will not exist, the tube walls can be significantly thinner. Scale buildup is not a problem with molten nitrate salt but tube corrosion and long-term salt degradation are issues that must be addressed in a realistic design.

In this study, it was assumed that a coal-fired salt heater would have many features in common with a coal-fired boiler. The coal-handling equipment, coal pulverizers, combustion air handling equipment, flue gas handling equipment, and pollution control equipment would be the same for both concepts except for size differences engendered by the continuous operation of the salt heater. The arrangement of heat transfer surfaces and the structural design of the salt heater were also assumed to be similar to the boiler. The major differences are caused by molten salt remaining a single-phase fluid throughout the heat transfer process. The salt heater does not require a separate preheater, evaporator, reheater, superheater, or ancillary equipment, such as the steam drum, moisture separator, and recirculation piping.

4.1.2 Analysis

The major differences between a coal-fired salt heater and a boiler are in the heat exchange surfaces; therefore, the analysis concentrated on characterizing the heat transfer surfaces in the coal-fired salt heater. Three analyses were conducted: a heat transfer evaluation, a pressure drop analysis, and tube stress calculations. The three sets of calculations provided the basis for selecting the furnace tubes, the distribution of heat exchange surfaces, and auxiliary equipment.

Several problems encountered in the analysis included uncertainty in salt properties and the lack of boiler design data in the open literature. While molten nitrate salt has been extensively investigated, substantial uncertainty still exists in the estimates for some important properties. The most important example is specific heat, where there are significant variations in the reported results (Carling 1983; Martin Marietta 1984; De Laquil, Kelly, and Egan 1988). The second difficulty was a lack of detailed boiler design data in the open literature. While boilers are a mature technology, the design data necessary to support the detailed design of a coal-fired salt heater was usually proprietary. To minimize these difficulties, the analysis characterized a conventional coal-fired boiler for a 500-MWe intermediate load power plant and a coal-fired salt heater that could provide the equivalent of 167 MWe if operated continuously. The comparison of the two designs highlights the advantages and disadvantages of each concept.

4.1.2.1 Heat Transfer

Typical convective heat transfer coefficients for water and molten nitrate salt are presented in Table 4.1. The values for molten salt are taken from Martin Marietta (1978) while the values for water and steam are taken from Kreith and Bohn (1986).

A review of Table 4.1 shows that, while molten nitrate salt is a good heat transfer fluid, the convective heat transfer coefficient is somewhat lower than for forced convection with water and substantially lower than for boiling

TABLE 4.1. Typical Convective Heat Transfer Coefficients for Water and Molten Salt

Fluid	Convective Heat Transfer Coefficient,	
	W/m ² -K	Btu/(h-ft ² -F)
Water, single phase	12,000	2,000
Water, boiling	60,000 to 120,000	10,000 to 20,000
Steam	300	50
Molten salt	6,000 to 9,000	1,000 to 1,500

heat transfer with water. Conversely, the convective heat transfer coefficient for molten salt is substantially greater than that presented for steam. While water has a higher convective heat transfer coefficient than molten salt, the impact on the design of a coal-fired salt heater is negligible because the resistance to heat transfer from the flue gas to water or molten salt is dominated by the external convective heat transfer coefficient between the external surface of a tube and the flue gas. Sorensen (1983) and Babcock and Wilcox (1978) report the overall heat transfer coefficient between flue gas and water as being between 50 W/m²-K [8.33 Btu/(h-ft²-F)] and 75 W/m²-K [12.5 Btu/(h-ft²-F)]. The resistance to heat transfer attributable to the convective heat transfer coefficient between an internal surface of a tube and water is less than 1% of the overall resistance. Obviously, the impact of water or molten-salt-side convective heat transfer coefficient can be ignored without loss of accuracy. This is not the case for steam because the steam-side convective heat transfer coefficient is much lower than for either water or molten salt. The major conclusion resulting from the evaluation of heat transfer coefficients is that molten salt will have heat transfer characteristics equivalent to water for convection or boiling heat transfer and will be superior to steam.

One disadvantage of molten salt is its low heat capacity. One kilogram of water will absorb approximately 2.33×10^6 J/kg (1000 Btu/lbm) as it passes through the boiler. The high heat capacity is caused by the water going through a phase change. Molten salt does not experience a phase change. This results in a substantial reduction in the heat capacity and a related

increase in the required mass flow rate for a molten salt system when compared to a similarly sized water/steam system. A study by Martin Marietta (1984) indicates that at 644 K (700°F), the specific heat of molten nitrate salt is estimated to be 1616 J/(kg-K) (0.386 Btu/lbm°F) with a density of 1849 kg/m³ (115 lbm/ft³). There is substantial variation in the reported values of specific heat for molten salt (Martin Marietta 1978, 1984; Kolb and Nikolai 1988; De Laquil, Kelly, and Egan 1988). This study used a value of 1550 J/(kg-K) (0.372 Btu/lbm°F), which was assumed to be independent of temperature.

The major conclusion is that the mass flow rate of molten salt is approximately six times greater than the mass flow rate of water for the same heat removal rate. The volume flow rate for molten salt will be approximately three times greater than that for water.

A typical boiler tube outside diameter is approximately 0.063 m (2.5 in.) (Babcock and Wilcox 1978). The wall thicknesses normally is around 0.004 m (0.17 in.). Wall thickness is determined by the pressure of the water/steam, corrosion requirements, and ease of fabrication.

Molten salt has been evaluated for use in solar central receiver systems (DOE 1988a,b). Evaluations have included the design and testing of molten salt central receivers. These activities resulted in the identification of the preferred tube design for solar applications. The recommended tube diameter was 0.038 m (1.5 in.) with a recommended tube wall thickness of 0.0017 m (0.065 in.) (Martin Marietta 1978). The molten salt would be at an approximate pressure of 1.724 MPa (250 psia), which would only require a wall thickness of 0.0006 m (0.0218 in.). The additional wall thickness is to facilitate fabrication. Given the low molten salt pressure and the high flow rates required in a coal-fired salt heater, it was concluded that tubing diameters of 0.063 m (2.48 in.) or larger should be used to minimize pressure drop. Pressure drop could probably be achieved using the same 0.0017 m (0.065 in.) wall thickness used in the smaller diameter tubing.

A molten salt solar receiver, using 0.0255-m (1.00-in.) diameter Incoloy 800 tubing was initially tested at a peak flux of 400,000 W/m² (Martin Marietta 1978). This was followed by a test of a 5 Mwt receiver, using 0.019-m

(0.75 in.) diameter tubes at the Central Receiver Test Facility. The receiver was designed for a peak flux of 0.6 Mwt/m^2 ($190,000 \text{ Btu/ft}^2\text{-h}$) (Delameter 1987; Bergan 1987). A high flux test exposed the receiver to flux levels above 1 Mwt/m^2 ($317,000 \text{ Btu/ft}^2\text{-h}$) for over 1 hour. The receiver survived the test with no damage. The second test confirmed that a conservative design peak flux for a molten salt receiver with Incoloy 800 tubes is 0.85 Mwt/m^2 ($269,000 \text{ Btu/ft}^2\text{-h}$) (Bergan 1987). Current molten salt solar central receiver designs are designed for a peak flux of approximately 0.75 Mwt/m^2 ($238,000 \text{ Btu/ft}^2\text{-h}$) using 316 stainless steel tubing (De Laquil, Kelly, and Egan 1988; DOE 1988b).

The results of the molten salt solar receiver development program suggest that the heat fluxes typically encountered in a coal-fired furnace [0.16 Mwt/m^2 ($50,700 \text{ Btu/ft}^2\text{-h}$)] can be readily accommodated in a coal-fired salt heater. A detailed design study for a coal-fired salt heater could possibly take advantage of the properties of molten salt to further improve the design but consideration of these issues was beyond the scope of this study.

4.1.2.2 Pressure Drop

Pressure drop across the salt heater is an important concern because of the threefold increase in the volumetric flow rate. It should be possible to minimize pressure drop by increasing the flow area for molten salt. The use of thin wall tubes along with closer spacing of the tubes (eliminating the "membrane bar" in coal-fired boilers) can be used to increase molten salt flow area.

Past pressure drop analyses and experiments are in good agreement and indicate that the friction factor for molten nitrate salt is comparable to water at the same Reynolds number (Martin Marietta 1984). Typically, the pumping power for molten salt necessary to overcome a fixed pressure drop at a fixed mass flow rate is only 35% of that for water. While the required mass flow rate for molten salt is a factor of 6 larger than for water, several factors can work to limit the impact on pumping power requirements. These include increased flow area and no increase in pressure drop caused by two-phase flow.

Previous solar receiver design studies and tests confirm that the pressure drop associated with using molten salt as a heat transfer fluid will be acceptable. Martin Marietta (1978) estimated the pressure drop across a 100 MWe solar central receiver using 0.0381-m (1.50-in.) diameter tubes and a fluid velocity of 3.35 m/s (1.0 ft/s) as being 1.1 MPa (160 psia). A more recent design for a 390 Mwt receiver design reported a frictional pressure drop across the receiver of 1.45 MPa (210 psia) while the measured pressure drop in a 5 Mwt receiver with 0.019-m (0.75-in.) diameter tubes was approximately 0.7 MPa (100 psia). Typical pressure drops through a conventional boiler are similar (Babcock and Wilcox 1978). For this design, it was assumed that a coal-fired salt heater would have a pressure drop approximately equal to that for a boiler. Standard calculation methods were used to determine the pump power size and power requirements.

4.1.2.3 Stress

The earliest solar thermal design studies selected Incoloy 800 as the material of choice for fabricating molten salt solar receiver tubes. Stress calculations showed that with a salt pressure of 1.72 MPa (250 psia), relatively thin wall tubing can be employed (Martin Marietta 1978). When tube diameters of 0.05 to 0.08 m (2 to 3 in.) were considered, a wall thickness of 0.0017 m (0.65 in.) was more than sufficient for containing the salt and was probably sufficient for efficient tube fabrication. These results were confirmed by testing (Martin Marietta 1984). The use of thin wall tubing is a significant advantage for molten salt. In addition to reducing the cost of the tubing, it results in increased flow area, smaller temperature difference across the tube wall, and reduced stresses. While a reasonable salt heater tube diameter was selected, the tube diameter was not optimized. Further design improvement might result from a more complete design study.

The study by Martin Marietta (1978) also suggested that stainless steel can be successfully used for solar receivers. More recent experience at the Central Receiver Test Facility has shown that type 304 stainless steel can be used for high-temperature molten salt applications (DOE 1988b; Kohl, Newcomb, and Castle 1987). Sandia National Laboratories also concluded that type 316 stainless steel is suitable for use in molten salt solar receivers and actually

showed better fatigue response than Incoloy 800 (DOE 1988b). For this study, type 304 stainless was selected for high-temperature uses and carbon steel was used for lower temperature applications.

4.1.2.4 Proposed Design

The heat transfer surfaces of a 167-MWe equivalent coal-fired salt heater and a 500-MWe coal-fired boiler were characterized and are compared on Table 4.2. The major differences between a coal-fired salt heater and coal-fired boiler are summarized below.

- Heat Transfer - Heat transfer in a molten salt heater is comparable to conventional boilers for most heat transfer surfaces and superior to conventional boilers for superheaters and reheaters.
- Wall Thickness - The low pressure experienced in the molten salt heater allows the use of thin wall tubing with savings in tube cost, reduced temperature difference across the tube walls, and reduced stresses.
- Flow Rate - The molten salt heater requires a substantially higher mass and volume flow rate than a conventional boiler. This results in an increase in pumping power.

The results of this evaluation suggest that a coal-fired salt heater is technically feasible and may have a number of advantages when compared to a conventional coal-fired boiler. The design of the coal-fired salt heater was not optimized; a more detailed evaluation may result in further improvements. The design process did identify several areas where further research is needed. These include better characterization of salt properties, such as specific heat, and further material compatibility testing to confirm that low-cost material can tolerate the severe environment encountered in a coal-fired furnace in long-term service and accommodate the required heat fluxes.

Even lacking accurate data on the above, our calculations show that a salt heater will be approximately equivalent to a steam boiler in performance and cost. Given the differences between the two designs, these conclusions appear reasonable.

TABLE 4.2. Steam Boiler Versus Salt Heater

Parameter/Heat Exchanger	500 MWe (1740 MWt) Steam Boiler	167 MWe (490 MWt) Salt Heater
Fluid	Water	Nitrate salt
Boiler/furnace ^(a)		
Tube material	S.S. 304	S.S. 304
Tube wall	9.5E-3 m (3/8 in.)	3.2E-3 m (1/8 in.)
Total surface area	4,370 m ² (47,000 ft ²)	1,750 m ² (18,800 ft ²)
Type	Finned, parallel flow	Contiguous, parallel flow
Economizer/heater ^(b)		
Tube material	SA285 Gr. A C.S.	SA285 Gr. A or similar C.S.
Tube wall	9.5E-3 m (3/8 in.)	3.2E-3 m (1/8 in.)
Total surface area	8,730 m ² (94,000 ft ²)	3,530 m ² (38,000 ft ²)
Type	Finned, counterflow	Finned, counterflow
Primary superheater/ heater ^(c)		
Tube material	S.S. 304	S.S. 304
Tube wall	9.5E-3 m (3/8 in.)	3.2E-3 m (1/8 in.)
Total surface area	8,670 m ² (93,300 ft ²)	8,015 m ² (86,300 ft ²)
Type	Plain, cross flow	Plain, cross flow
Secondary superheater ^(c)		
Tube material	S.S. 304	-
Tube wall	1.4E-2 m (9/16 in.)	-
Total surface area	8,670 m ² (93,300 ft ²)	-
Type	Plain, cross flow	-
Reheater ^(c)		
Tube material	S.S. 304	-
Tube wall	4.8E-3 m (3/16 in.)	-
Total surface area	8,670 m ² (93,300 ft ²)	-
Type	Plain, cross flow	-
Total area for all heat exchangers	39,100 m ² (422,000 ft ²)	13,300 m ² (143,000 ft ²)
Feed pump installed capacity ^(d)	14.2 MWe	2.0 MWe

- (a) This category represents heat transfer surfaces located on the furnace walls. In the case of the steam boiler, this is the boiler.
- (b) This category represents heat transfer surfaces located in the low-temperature convective passes. In the case of the steam boiler, it includes the economizer.
- (c) This category represents heat transfer surfaces located in the high-temperature convective passes. In the case of the steam boiler, it includes the primary and secondary superheater and reheater.
- (d) This includes pumping power to overcome frictional pressure drop and to pressurize water. In the case of the salt heater, pump power only included the pumping power required to overcome frictional pressure drop.

4.2 SALT TRANSPORT SUBSYSTEM

To characterize the salt transport subsystem, a conceptual layout for the nitrate salt storage tanks, hot salt piping, cold salt piping, and pumps was developed. The major components of the transport subsystem were sized and the thermal and pumping requirements were calculated. Thermal losses, which include warmup losses and trace heating, were based on recent experimental and analytical work performed for DOE's Solar Thermal Program (Kolb and Nikolai 1988; Martin Marietta 1985; De Laquil, Kelly, and Egan 1988). The design of the transport subsystem was subsequently used to develop a cost estimate for the subsystem.

4.3 SALT STORAGE SUBSYSTEM

The salt storage subsystem temporally separates the production of thermal energy in the coal-firing equipment from the production of electricity. The storage subsystem must store hot salt at 566°C (1050°F) for extended time periods without excessive thermal losses or capital cost. Material compatibility requires expensive materials (relative to carbon steel) to contain hot molten salt. The main design problems are related to minimizing the use of expensive materials in the storage vessels. Molten nitrate salt TES has been extensively investigated for solar thermal applications. Where possible, the current evaluation has relied on the results of these studies.

4.3.1 Design Options

Two design options have been proposed for the nitrate salt TES subsystem. The first option uses one tank with the hot and cold salt separated by a thermocline (Martin Marietta 1978). The second option uses separate hot and cold molten salt tanks (Martin Marietta 1985).

The thermocline system is attractive because only one tank is required. The thermocline is formed by adding or removing hot salt from the top of the tank and adding or removing cold salt from the bottom of the tank. The lower density of the hot salt keeps the hot salt in the upper region of the tank while the cold salt occupies the lower region. The narrow zone between the hot and cold regions is the thermocline.

The most recent studies suggest that the cost savings associated with a thermocline system are small because the cost of the cold tank in the two-tank system is a small fraction of the total cost. In addition, it may be difficult to maintain the thermocline because of radiation heat transfer between the hot and cold regions of the tank.

The two-tank system uses a separate hot and cold tank. This avoids difficulties associated with maintaining the thermocline. All recent studies have selected a two-tank system (Martin Marietta 1985; Ross, Roland, and Bouma 1982; Delameter 1987; DOE 1988a).

4.3.2 Proposed Design

The maximum size of a molten salt storage tank is limited in diameter by the maximum realistic tank wall thickness. Large-diameter tanks with a wall thickness exceeding 0.038 m (1.5 in.) must undergo post-weld heat treatment. Post-weld heat treatment is prohibitively expensive (Martin Marietta 1985). This limits the maximum tank diameter to approximately 25 m (82 ft). The maximum tank height is limited by the soil-bearing strength. Assuming a soil-bearing strength of 0.24 MPa (50 psia), the maximum height of the stored hot salt will be 13 m (42.6 ft). This results in a useful storage volume with a diameter of approximately 25 m (82 ft) and a height of 13 m (42.6 ft). The actual tank dimensions will be somewhat larger to accommodate an inert cover gas (Martin Marietta 1985). With a maximum storage volume of around 6000 m³ (212,000 ft³), multiple hot and cold salt tanks will be required. The hot tank design is externally insulated and uses 316 stainless steel or even less expensive 304 stainless steel for the wall material (DOE 1988a; De Laquil, Kelly, and Egan 1988). With external insulation, the integrity of a tank is unaffected by insulation failure. Nonconventional tank configurations, such as the conical tank design proposed in Kohl, Newcomb, and Castle (1987) have the potential to reduce tank costs but require additional research and demonstration.

The cold tank has dimensions similar to the hot tank. The cold tank walls are fabricated from A516 carbon steel with external insulation (DOE 1988a; De Laquil, Kelly, and Egan 1988).

Salt freeze protection may be required, although the long time span before freezing occurs in such large vessels (3 to 6 months) suggests that freeze protection may not be a critical issue (Ross, Roland, and Bouma 1982). The tanks will be enclosed in dikes to contain salt spills.

4.4 STEAM GENERATOR SUBSYSTEM

During peak demand periods, thermal energy is extracted from storage and used to produce steam for a conventional Rankine cycle steam power cycle. Steam production occurs in the steam generation subsystem, which consists of a number of heat exchangers where thermal energy is transferred from the molten salt to water or steam. DOE's Solar Thermal Program has conducted three design studies of molten salt steam generator systems for molten salt solar central receiver systems (Martin Marietta 1978; Ross, Roland, and Bouma 1982; Weber 1980) and two more recent studies (DOE 1988b; De Laquil, Kelly, and Egan 1988). These studies form the basis for the design described below.

4.4.1 Description

The steam generator subsystem consists of four separate heat exchangers: 1) a preheater where the temperature of the feedwater is raised to the saturation temperature; 2) an evaporator where steam is generated; 3) a superheater where the saturated steam is superheated; and 4) a reheater where the high-pressure turbine exhaust is heated to 538°C (1000°F). The design will be presented as if each heat exchanger were in one shell but, given their large size, multiple parallel heat exchanger trains will be used.

A recirculating steam generation arrangement is proposed. The evaporator includes a steam drum and steam separator. A mixture of water and steam enters the steam separator where the vapor phase is separated for the liquid phase and sent to the superheater. The liquid is recirculated to the evaporator.

4.4.2 Proposed Design

The heat exchangers are single-pass tubular heat exchangers with water/steam being contained within the tubes. A single-pass design was selected because of the desire to have counterflow heat exchange in the preheater,

superheater, and reheater. Internal baffling will be arranged so that molten salt flow approximates a counterflow arrangement (Martin Marietta 1978). The modifications to the internal baffling significantly reduce the salt pressure drop but adversely affect the heat exchangers (Martin Marietta 1978; Kays and London 1964). The evaporator uses a parallel-flow arrangement (Ross, Roland, and Bouma 1982).

The heat exchanger designs use long tubes with the smallest shell diameter consistent with reasonable salt pressure drop. This results in a heat exchanger design with a 15 to 20 m (49 to 66 ft) length and a shell diameter of 1 to 2 m (39 to 79 in.) (Martin Marietta 1978).

Characteristics of the four heat exchangers are presented on Table 4.3. The design specifications are based on the designs proposed by Martin Marietta (1978). The designs have been modified to reflect current design practices in reference to design margin and materials selection. Alternative designs using a U-shell design (DOE 1988a; De Laquil, Kelly, and Egan 1988) and hemispherical head arrangements (Ross, Roland, and Bouma 1982) have been proposed but would most likely be more expensive than the conventional designs selected here.

TABLE 4.3. Heat Exchanger Specifications

<u>Parameter</u>	<u>Preheater</u>	<u>Evaporator</u>	<u>Superheater</u>	<u>Reheater</u>
Heat transfer surface, m ²	21,700	21,800	3,150	4,100
Approx. shell diameter, m	1 to 1.5	1 to 1.5	1.5 to 2	1.5 to 2
Approx. tube length, m	20	20	15	15
Tube O.D., m	0.016	0.016	0.016	0.016
Tube wall thickness, m	0.00163	0.00163	0.00163	0.00163
Baffle spacing, m	0.75	0.75	0.00	0.75
Material	Carbon steel	2-1/4 Cr-1 Mo ^(a)	S.S. 304 ^(b)	S.S. 304
Number of heat exchangers required	2 to 4	2 to 4	2	2

(a) 2-1/4% chrome, 1% molybdenum

(b) S.S. = stainless steel

4.5 BALANCE-OF-PLANT

The balance-of-plant includes conventional electric power-generating equipment as well as cooling towers. The power generating equipment consists of a reheat condensing steam turbine with separate high- and low-pressure turbines. Condensate pumps, a deaerator, feed pumps, feedwater heat exchangers, and a shell-and-tube type condenser operating at 2.5 in. Hg (absolute), plus wet cooling towers, would provide the full complement of equipment necessary for a working electric power-generating facility.

4.6 PERFORMANCE EVALUATION

The performance evaluation involved two issues: the heat rate of the plant with molten salt TES as compared to a conventional cycling plant and the availability of a plant with molten salt TES relative to the conventional cycling plant.

The determination of plant heat rates involved taking a heat rate for a base load coal-fired power plant and adjusting the heat rate to account for special features associated with the conventional cycling plant and the plant with molten salt TES. The heat rate for a 500 MWe base load coal-fired power plant was taken from EPRI's Technical Assessment Guide (1986a) and was estimated to be 10,060 Btu/kWe.

In the case of the cycling coal plant, the heat rate was adjusted for increased fuel and parasitic power use during daily startups. Startup fuel use was estimated by assuming that the boiler would be started after a controlled shutdown 10 hours earlier. It was assumed that fuel oil would be used to warm-up the steam generator. Fuel consumption associated with starting the turbine was not included because both concepts involve daily cycling of the turbine. A daily startup was assumed to consume 18 m³ (4800 gal) of fuel oil and 4000 kWe of parasitic power. The heat rate for the conventional cycling plant was adjusted for these factors and the resulting annual heat rate was 10,192 Btu/kWe.

The heat rate for the plant with a molten salt TES unit involved a number of adjustments to the base load heat rate of 10,060 Btu/kWe. First, the heat

rate was adjusted for the smaller size of the coal-fired salt heater when compared to the coal-fired steam generators. Parasitic losses for the TES system include pumping power, thermal losses from the storage tanks, and trace heating power consumption. Pumping power was determined as part of the engineering design study. Thermal losses and trace heating power consumption were taken from estimates developed for DOE's Solar Thermal Program (Kolb and Nikolai 1988; Martin Marietta 1985). In addition, the parasitic power consumption of the boiler feed pump was adjusted downward to account for the lower pressure drop in the salt-heated steam generator when compared to the coal-fired salt heater. The resulting annual heat rate for the plant with a molten salt TES unit was 10,224 Btu/kWe (an efficiency of 33.4%). Given the accuracy of the study, the conclusion was that the two designs have essentially similar heat rates.

Availability is the fraction of time that a power plant is available to produce power. Historically, smaller coal-fired power plants have had a higher availability than larger plants. This observation is in agreement with the plant availabilities reported in EPRI's Technical Assessment Guide (1986a). Plant outages involve two components: planned outages and unplanned outages. A comparison of coal-fired power plants with oil-fired plants showed that coal firing added little to the planned outage rate. The major difference was in the unplanned outage rate. A review of operation and maintenance costs suggested that 80% of unplanned outages were related to coal handling, coal firing, and flue gas cleaning. This was used to allocate unplanned outages between the coal-firing equipment and the balance of the plant. The outage rate for the coal-firing equipment was then adjusted for the smaller size of the equipment. The results are summarized on Table 4.4. These results are based on the assumption that a non-cycling coal-fired salt heater will have the same unplanned outage rate as a conventional cycling coal-fired steam generator of the same size.

TABLE 4.4. Plant Availability

<u>Equivalent MWe Capacity</u>	<u>Availability</u>
333	0.743
250	0.759
188	0.770
167	0.775
125	0.783
Cycling coal power	0.712

5.0 ECONOMIC EVALUATION

This section presents detailed information regarding the cost and economic analysis of conventional coal-fired and coal-fired power plants with molten salt TES. Section 5.1 defines the specific cost estimating and economic assumptions used in the analysis. Section 5.2 discusses the specific estimating approach and initial capital cost results for conventional coal-fired power plant and molten salt system components. The specific estimating approach and cost results for fuel and other O&M costs are discussed in Section 5.3. Section 5.4 presents the results of the levelized energy cost analysis.

5.1 GROUND RULES AND ASSUMPTIONS

The economic assumptions used to calculate the levelized energy costs are listed in Table 5.1. Each of these assumptions was either taken directly or calculated from data in EPRI's Technical Assessment Guide (1986a) except for the combined federal and state income tax, price year, the first year of plant operation, the fuel inflation rate, and the construction period for coal-fired power plants with molten salt TES. Brown et al. (1987) was the reference for the combined state and federal tax rate. The first year of operation was set at the year 2000 because this was felt to be a reasonable time frame for bringing TES on-line with new power plants. A price year of 1987 was selected as a matter of convenience because the most recent data available were already estimated in 1987 dollars. The selection of the fuel price inflation rate is discussed in Section 5.3.

As noted in Table 5.1, the plant construction period for the coal-fired plant with molten salt TES might be less than for the conventional coal-fired power plant. EPRI's Technical Assessment Guide (1986a) specifies plant construction periods of 3 and 4 years, respectively, for 200 MWe and 500 MWe conventional coal-fired power plants. Similarly, Power Magazine (June 1988) indicates that 300 MWe coal-fired power plants are likely to have construction periods from 6 months to 1 year shorter than 600 MWe power plants. Coal-fired power plant construction schedules prepared by United Engineers & Constructors

TABLE 5.1. Financial Assumptions

<u>Description</u>	<u>Assumption</u>
Discount rate	10.5% (nominal)
General inflation rate	6.0%
Capital inflation rate	6.0%
O&M inflation rate	6.0%
Fuel inflation rate	7.0%
Investment tax credit	0.0%
Property tax and insurance rate	2.0%
Combined State and Federal income tax rate	39.1%
Plant economic life	30 years
Plant depreciable life	20 years
Plant construction period	
Conventional coal plant	4 years
Coal/TES plant	3 or 4 years
Price year	1987
First year of plant operation	2000

(UE&C) (1988) also indicate that the boiler is on the critical path to construction. Because the coal-firing equipment is downsized in a coal-fired plant with molten salt TES, it may have a shorter construction period, providing the construction of the molten salt components does not add to the scheduling problems. In this study, a 4-year construction period was assumed as the reference situation and a 3-year construction period was evaluated as a sensitivity case.

5.2 CAPITAL COST ESTIMATES

Capital cost estimating equations were developed for five conventional coal-fired power plant components (coal-handling, boiler, emissions-handling, power generation, and balance-of-plant), four molten salt components (coal-fired salt heater, transport, storage, and steam generator), plus startup expenses, working capital, and land. The following two subsections present the specific estimating approach and cost results for the conventional coal-fired power plant and the molten salt components.

5.2.1 Conventional Power Plant Component Costs

The general approach to characterizing the costs associated with a conventional coal-fired power plant was to first estimate costs for a plant power rating of 500 MWe and then develop individual equations for major power plant components. The cost equations estimate costs as a function of plant power rating. The reference technology is a conventional subcritical coal-fired power plant sited in the midwestern United States. The unit burns high-sulfur midwestern bituminous coal to produce steam at 16.54 MPa (2400 psia) and 538°C (1000°F) with a single reheat to 538°C (1000°F). A wet limestone flue gas desulfurization system is employed. Additional specifications for the reference plant can be found in EPRI's Technical Assessment Guide (1986a).

Relatively detailed estimates of the cost for the conventional coal-fired power plant were necessary to segregate cost elements into those that are related to coal-firing capacity and those that are related to power-generating capacity. The capacity and costs for the former will vary in the coal-fired power plant with molten salt TES, depending on the plant design power generation schedule, while the capacity and costs for the latter are fixed. Reference coal plant costs were taken from a design and cost study prepared by UE&C (1987) for the Energy Economic Data Base Program operated by Oak Ridge National Laboratory. The UE&C study was selected as the reference cost source because 1) the design conditions in the UE&C study were essentially identical to the reference conditions specified in EPRI's Technical Assessment Guide, 2) the cost estimate was presented in detail, and 3) it was an up-to-date source.

The direct capital costs estimated in the UE&C study are listed in Table 5.2. Table 5.2. also identifies the assigned capital cost account for this study and indicates whether the component is presumed to vary with the plant's coal-firing capacity (designated as "variable") or vary with the plant's power generation capacity (designated as "fixed"). Assignment to a particular PNL capital cost account and fixed or variable status was established by reviewing the specific equipment descriptions provided in the UE&C study for their capital cost accounts. The UE&C estimates are in January 1987 dollars and were adjusted upward by 1.5% to reflect price increases to mid-1987, the reference time point for this study.

TABLE 5.2. United Engineers & Constructors Study Coal Plant Costs
(January 1987 dollars)

<u>UE&C Cost Account</u>	<u>Direct Cost</u>	<u>PNL Cost Account</u>	<u>Status</u>
Yard work	12,923,780	Balance-of-plant	Fixed
Steam generator bldg.	23,138,166	Boiler	Variable
Turbine, heater, and control bldg.	14,932,247	Power generation	Fixed
Administration bldg.	3,179,826	Balance-of-plant	Fixed
Electrical switchgear bldgs.	76,044	Coal handling	Variable
Stack/reclaim transfer tower	458,065	Coal handling	Variable
Coal car thaw shed	585,246	Coal handling	Variable
Rotary car dump bldg.	739,933	Coal handling	Fixed
Coal breaker house	1,271,075	Coal handling	Variable
Coal crusher house	752,006	Coal handling	Variable
Boiler house transfer tunnel	197,484	Coal handling	Variable
Dead storage transfer tunnel	573,356	Coal handling	Variable
Waste water treatment bldg.	1,055,849	Balance-of-plant	1/2 Fixed 1/2 Variable
Locomotive repair garage	483,246	Balance-of-plant	Fixed
Material handling and service bldg.	452,943	Balance-of-plant	Variable
Misc. coal handling	4,823,955	Coal handling	2/3 Fixed 1/3 Variable
Stack structure	6,293,254	Emissions handling	Variable
Fossil steam supply	68,516,500	Boiler	Variable
Steam generating system	1,536,886	Boiler	Variable
Draft system	13,654,300	1/2 Boiler 1/2 Emissions handling	Variable
Ash and dust handling	8,501,795	Emissions handling	Variable
Fuel handling systems	29,770,332	Coal handling	Variable
Flue gas desulfurization structures	17,011,971	Emissions handling	Variable

TABLE 5.2. (contd)

<u>UE&C Cost Account</u>	<u>Direct Cost</u>	<u>PNL Cost Account</u>	<u>Status</u>
Desulfurization equip.	77,704,982	Emissions handling	Variable
Boiler inst. and control	10,365,853	Boiler	Variable
Misc. boiler plant	3,088,402	Boiler	Variable
Turbine generator	54,327,642	Power generation	Fixed
Condensing systems	9,180,755	Power generation	Fixed
Feed heating system	11,068,131	Power generation	Fixed
Other turbine plant	18,785,030	Power generation	Fixed
Turbine inst. and control	161,434	Power generation	Fixed
Misc. turbine plant	3,176,302	Power generation	Fixed
Switchgear	7,424,001	Balance-of-plant	1/3 Fix. 2/3 Variable
Station service equip.	5,914,946	Balance-of-plant	1/3 Fixed 2/3 Variable
Switchboards	1,167,062	Balance-of-plant	1/3 Fixed 2/3 Variable
Protective equipment	3,294,533	Balance-of-plant	2/3 Fixed 1/3 Variable
Electrical structures and wiring containers	11,533,871	Balance-of-plant	Fixed
Power and control wiring	9,914,173	Balance-of-plant	1/3 Fixed 2/3 Variable
Transportation and lift equipment	2,286,905	Balance-of-plant	Fixed
Air, water, and steam service systems	14,485,420	Balance-of-plant	1/2 Fixed 1/2 Variable
Communications equip.	1,528,551	Balance-of-plant	Fixed
Furnishings and fixtures	1,149,301	Balance-of-plant	Fixed
Waste water treatment	5,034,127	Balance-of-plant	1/2 Fixed 1/2 Variable
Heat rejection struc.	2,650,053	Power generation	Fixed
Heat rejection equip.	18,271,824	Power generation	Fixed
<hr/>			
Total direct construction cost	483,441,557		

Two other direct construction cost elements (switchyard and generator step-up transformer) were not included in the UE&C estimate and were estimated separately. The costs for these two elements were derived from data in EPRI-4542 (EPRI 1986b) and the EPRI Technical Assessment Guide (1986a) and were estimated to be \$11,080,000 for the switchyard and \$4,430,000 for the generator step-up transformer in mid-1987 dollars. Total direct construction costs are summarized by PNL cost account and its fixed (power generation capacity related) or variable (coal-firing capacity related) nature in Table 5.3.

Indirect construction costs, sales tax, and contingency were added to the direct construction cost to arrive at the complete "overnight" construction cost (i.e., not including interest or escalation during construction that were included in the economic methodology). Indirect construction costs were estimated at 25% of direct costs based on the ratio of indirect to direct costs presented in the UE&C study. Contingency was estimated at 15% of the sum of direct and indirect costs based on estimates presented in EPRI-4542 (EPRI 1986b). State and local sales taxes were estimated at 3% of the sum of direct and indirect costs. The national average sales tax rate is about 5% (Mahoney 1986), but only applies to direct and indirect materials and equipment (not construction labor), which were about 60% of the total UE&C estimate.

TABLE 5.3. Total Direct Construction Costs, 500 MWe Power Plant
(mid-1987 dollars)

<u>Description</u>	<u>Costs</u>	
Coal handling	\$35,809,674	variable
	\$4,013,976	fixed
Boiler	\$115,138,740	variable
Emissions handling	\$118,047,011	variable
Power generation	\$134,499,302	fixed
Balance-of-plant	\$70,008,051	fixed
	\$28,531,726	variable

Total initial capital costs were determined by adding costs for startup, working capital, and land to the construction cost. The costs for these three elements were derived from data presented in EPRI-4542 (EPRI 1986b) and the EPRI Technical Assessment Guide (1986a). The costs for these three items are summarized in Table 5.4.

Equations estimating the direct construction costs of conventional coal-fired power plants as a function of plant power rating were developed by a two-step process. The first step was to determine the economy-of-scale factor controlling relative costs at different plant power ratings for each major plant cost account (the cost accounts listed in Table 5.3). The economy-of-scale factor is defined as the exponent "B" in the following generalized equation:

$$\text{Cost} = A * (\text{Plant Power Rating})^B \tag{5.1}$$

where A and B are correlation constants.

The second step was to solve for the values of "A" in the above generalized equation that would yield the estimates shown in Table 5.3, given the economy-of-scale factors ("B" values) identified in the first step.

Economy-of-scale factors for each account were determined by analyzing existing economy-of-scale studies. Unfortunately, most of the studies identified had the following shortcomings: 1) the cost data were too highly aggregated (the cost accounts were too broad), 2) the cost accounts were not comparable to the code of accounts established for this study, 3) the focus

TABLE 5.4. Startup, Land, and Working Capital Costs
(mid-1987 dollars; 500 MWe Power Plant)

Description	Cost
Startup	\$18,250,000
Working capital	
Initial fuel and chemicals	\$4,550,000
Spare parts	0.5% of construction cost
Land	\$1,960,000

was on power plant sizes near the upper end or beyond the range of interest (125 to 500 MWe) for this study, and 4) normalization of data was often limited to the price year, ignoring factors such as changes in labor productivity and plant design requirements. However, Stevenson and Walker (1987) presented detailed cost for six different power plant capacities ranging from 250 MWe to 865 MWe. Cost data from Stevenson and Walker (1987) were combined into the PNL cost accounts and are shown in Table 5.5 for the three plant sizes of interest to this study. Regression analysis techniques were applied to the data in Table 5.5 to determine the economy-of-scale factor for each of the cost accounts. In turn, the economy-of-scale factors and costs for the reference size coal-fired power plant were used to develop the direct construction cost estimating equations shown in Table 5.6. Note that the exponent in each of the estimating equations is the economy-of-scale factor.

TABLE 5.5. Economy-of-Scale Factor Cost Data
(1986 dollars)

Cost Account	Plant Power Rating, MWe		
	250	350	500
Coal handling			
fixed	505,133	692,069	692,069
variable	11,741,234	12,400,112	15,618,202
Boiler (variable)	61,876,921	85,799,651	107,325,325
Emissions handling ^(a) (variable)	24,625,599	28,782,871	42,095,991
Power generation (fixed)	74,979,743	87,236,997	119,273,349
Balance-of-plant			
fixed	56,754,185	75,357,579	95,137,965
variable	14,288,732	17,987,282	24,651,472
Total	244,771,545	308,256,558	404,794,372

(a) Fluid gas desulfurization system is not included in estimate.

**TABLE 5.6. Direct Construction Cost Estimating Equations
(mid-1987 dollars)**

<u>Description</u>	<u>Equation</u>
Coal handling	
fixed	$248,063 \times (\text{PGC})^{0.450}$
variable	$2,760,629 \times (\text{CFC})^{0.414}$
Boiler (variable)	$850,576 \times (\text{CFC})^{0.793}$
Emissions handling (variable)	$965,255 \times (\text{CFC})^{0.776}$
Power generation (fixed)	$2,102,423 \times (\text{PGC})^{0.672}$
Balance-of-plant	
fixed	$698,157 \times (\text{PGC})^{0.744}$
variable	$217,516 \times (\text{CFC})^{0.789}$

PGC = Power generation capacity, MWe

CFC = coal-firing capacity, MWe (equivalent)

5.2.2 Molten Salt Component Costs

Molten salt components include the salt heater, salt transport subsystem, salt storage subsystem, and steam generator. This section of the report discusses the estimating approach and cost results for these components.

The coal-fired salt heater was estimated to cost from 65% to 75% of the cost of a boiler of equivalent thermal rating based primarily on the difference in their operating pressures. The boiler operates at a nominal pressure of approximately 16.54 MPa (2400 psia) while the salt heater pressure will be between 0.69 MPa (100 psia) and 1.38 MPa (200 psia). Based on an estimating rule-of-thumb from Guthrie (1974) defining the relative costs of process furnaces as a function of tube pressure, the salt heater would be about 30% less costly than the boiler. The other design differences distinguishing the boiler from the salt heater have a cost impact that is trivially small by comparison. The total heat transfer area, the mix between finned and unfinned tubing, and the mix between stainless steel and carbon steel tubing are about

the same for the boiler and the salt heater. Although the salt heater does not require a steam drum and some related steam piping, the estimated cost of these components (about 1% of the cost of the boiler) is well within the uncertainty of the cost reduction associated with pressure differential and was not specifically excluded. The resulting cost estimating equation for molten salt heaters (based on 70% of the cost of a boiler with the same thermal power rating) is

$$\$595,400 \times (\text{Coal-Firing Capacity, MWe})^{0.793}. \quad (5.2)$$

Molten salt transport costs were estimated from designs prepared by PNL for the piping system interconnecting the salt heater, salt storage subsystem, and steam generator. Design information was prepared for three different coal-firing capacities covering the range of plant configurations being investigated. Regression analysis was applied to the costs estimated at the three design points to develop a cost estimating equation as a function of coal-firing capacity. The costs estimated for the three design points and the resultant estimating equation are presented in Table 5.7. The design maturity

TABLE 5.7. Molten Salt Transport Costs
(mid-1987 dollars)

<u>Component</u>	<u>Coal-Firing Capacity</u>		
	<u>138 MWe</u>	<u>277 MWe</u>	<u>375 MWe</u>
Pipe	1,047,224	1,658,047	1,821,946
Insulation, supports	747,927	1,233,180	1,421,483
Crosses	111,302	125,800	142,119
Tees	44,728	111,013	128,730
Ells	269,204	410,306	487,443
Valves	965,956	1,339,307	1,559,686
Pumps	805,790	1,034,111	1,117,398
Subtotal	3,992,131	5,911,764	6,678,805
Total, including 30% safety factor for design maturity	5,189,770	7,685,293	8,682,447

$$\text{Molten Salt Transport Costs} = 394,630 \times (\text{Coal Firing Capacity})^{0.524}$$

factor applied to the basic estimate is a rule-of-thumb allowing for piping complexities unforeseen in a conceptual design.

Molten salt systems have been a key element of solar thermal central receiver power plant technology development for many years. Although the technology has not been deployed on a full scale, considerable analysis and pilot-plant level testing has been completed. In short, the Solar Thermal Program sponsored by the DOE has spearheaded the development and analysis of molten salt storage, molten salt steam generation, and related molten salt components. The latest developmental effort is focussed on a design study being conducted by Arizona Public Service (APS) (DOE 1988a,b), Pacific Gas and Electric (PG&E) (De Laquil, Kelly, and Egan 1988), and a number of other organizations. The information developed in the studies conducted by these organizations represents the current state-of-the-art for molten nitrate salt system designs and costs. For these reasons, the studies completed by APS and PG&E were used as the reference for developing estimating equations for molten salt storage and molten salt steam generators.

Designs and cost estimates were prepared for storage system capacities ranging from about 100 MWht to 5000 MWht in the studies mentioned above. Multiple hot and cold tanks are required at the upper end of this range, but the maximum capacity allowable in a single hot or warm tank is subject to debate. Two subcontractors to APS prepared different tank designs and reached different conclusions regarding the maximum permissible size of the hot tank. CBI Industries recommended limiting the capacity of a single hot tank to approximately 1500 MWht, while the designs prepared by Pitt-Des Moines, Inc., included a single hot tank with a capacity of 3120 MWht. A single, 3210-MWht capacity warm tank was specified by both organizations (DOE 1988b).

Storage system costs for coal-fired power plants with molten salt TES were based on maximum hot and warm tank capacities of 1500 MWht and 3200 MWht, respectively. The coal-fired plants with molten salt TES have storage capacity requirements ranging from 5700 MWht to 7600 MWht, resulting in multiple hot and warm tanks in approximately a 2:1 ratio. With little difference in individual tank sizes, the same unit cost was presumed to apply for all of the

coal-fired plants with molten salt TES storage systems. An average direct capital cost of \$11/kWh was established based on estimates prepared by CBI Industries for storage systems with two-hot tanks and one-warm tank (DOE 1988b).

A cost estimating equation for molten salt steam generators was also developed from cost data presented in the APS/PG&E studies. Steam generator costs were estimated in the APS/PG&E studies for power plants with capacities up to 400 MWe. An estimating equation was developed from cost data at the 100, 200, and 400 MWe design points and was used to predict a direct cost of \$21.5 million for a 500-MWe steam generator.

5.3 OPERATING AND MAINTENANCE COSTS

Operating and maintenance costs are defined here to include fuel, operating labor, operating materials (consumables), maintenance labor, and maintenance materials. Non-fuel O&M costs were split into fixed (constant regardless of plant power output), variable (proportional to plant power output), and consumables (also proportional to plant power output) elements for the conventional coal-fired power plant components. Aggregated non-fuel O&M costs were estimated for molten salt piping, storage, and steam generation. Molten salt heater O&M costs were assumed to be similar to a coal-fired boiler. The following three sections define the specific estimating approach and results for fuel costs, conventional plant O&M, and molten salt component O&M.

5.3.1 Fuel Costs

Current and future fuel costs were established from projections by several organizations for high-sulfur coal delivered to a utility in the Midwest from Midwestern mines. The sources consulted were published by EPRI (1986a), the Energy Information Administration (1988a), Data Resources Incorporated (1988), the Gas Research Institute (Holtberg, Woods, and Ashby 1987), and Wharton (1987). Based on a current coal price of \$1.50/million Btu in mid-1987, the rate of real (relative to general inflation) price increases predicted by the several sources ranged from 0%/yr to 2%/yr. The middle of this range, or 1% real price escalation per year, was chosen for the economic analysis. It

should be noted that, although there is considerable uncertainty in future energy prices, fluctuating coal prices would not have a significant impact on the difference between levelized energy costs for the conventional coal-fired plant and coal-fired plant with molten salt TES because the two types of plants are estimated to have similar annual heat rates.

5.3.2 Conventional Plant Non-Fuel Operating and Maintenance Costs

As noted above, conventional plant non-fuel O&M costs were divided into fixed, variable, and consumable categories. Costs were also segregated into coal-firing related and power-generation related categories to allow a distinction between O&M costs for the conventional coal-fired plant and the coal-fired plant with TES. Operation and maintenance cost data were obtained from EPRI's Technical Assessment Guide (1986a) and an Energy Information Administration (1988b) annual report on "Historical Plant Cost and Annual Production Expenses for Selected Electric Plants."

Consumables include items such as lime, limestone, water, and chemicals that are consumed in proportion to a plant's energy output. Approximately 90% of the consumables for a coal-fired power plant are related to the coal-firing equipment (EPRI 1986a). There is no economy of scale associated with consumables (EPRI 1986a). The same unit cost applies over the range of coal-firing equipment being considered in this study. Thus, the charge per kWh is not affected by the downsizing of the coal-firing equipment in the coal-fired plant with molten salt TES. EPRI's estimate for consumables in its Technical Assessment Guide (1986a) was updated to a mid-1987 value of 3.43 mills/kWh.

Variable O&M is essentially maintenance labor and material costs that are proportional to the plant energy output. Unlike consumables, the variable O&M rate does depend on plant size. Thus, it was important to segregate variable O&M costs into coal-firing related and power-generation related parts. Variable O&M cost data in EPRI's Technical Assessment Guide (1986a) were used to develop an estimating equation of total variable costs (mills/kWh) as a function of plant generating capacity. Total variable costs were split into coal-firing related and power-generation related parts based on the split in coal-firing and power-generation capital costs for the reference 500-MWe plant

and the relative maintenance costs (as a fraction of initial investment) of equipment in the more severe coal-firing environment compared to the power generation environment (EPRI 1986a). The resulting equations for variable O&M costs are shown below.

$$\begin{array}{l} \text{Coal-Firing Related} \\ \text{Variable O\&M Costs} \end{array} = 42 \times (\text{Coal-firing capacity, MWe})^{-0.489} \text{ mills/kWhe} \quad (5.3)$$

$$\begin{array}{l} \text{Power-Generation} \\ \text{Related Variable} \\ \text{O\&M Costs} \end{array} = 9.5 \times (\text{Power-generation capacity, MWe})^{-0.489} \text{ mills/kWhe} \quad (5.4)$$

Fixed O&M costs include operating labor, maintenance, and overheads. Like variable O&M, fixed O&M also shows economy-of-scale with plant power rating. The split in fixed O&M costs between coal-firing related and power-generation related parts was derived by first developing an equation predicting total fixed O&M costs as a function of plant power rating from data in EPRI's Technical Assessment Guide (1986a). Next, data from the Energy Information Administration's report on Historical Plant Cost and Annual Production Expenses (1988b) was used to determine an average overall split between coal-firing and power-generation related O&M for the sum of consumables, variable, and fixed costs. The coal-firing and power-generation related O&M costs previously defined were then subtracted from the total to solve for the coal-firing/power-generation split in fixed costs. The resulting cost estimating equations for fixed O&M costs are shown below.

$$\begin{array}{l} \text{Coal-Firing} \\ \text{Related Fixed} \\ \text{O\&M Costs} \end{array} = 346 \times (\text{Coal-firing capacity, MWe})^{-0.489} \text{ \$/kWe-yr} \quad (5.5)$$

$$\begin{array}{l} \text{Power-Generation} \\ \text{Related Fixed} \\ \text{O\&M Costs} \end{array} = 195 \times (\text{Power-generation capacity, MWe})^{-0.489} \text{ \$/kWe-yr} \quad (5.6)$$

5.3.3 Molten Salt Component Non-Fuel Operating and Maintenance Costs

Operation and maintenance costs for the molten salt piping, storage, and steam generator components were estimated separately from the conventional coal-fired power plant components. As was already noted, O&M for the salt heater was assumed to be the same as for the coal-fired boiler and is included in the fixed, variable, and consumable O&M estimates described above for the conventional coal-fired power plant components. Operation and maintenance costs for salt piping, salt storage, and steam generation were established based on data presented in the APS/PG&E study and in another solar thermal technology study conducted by PNL (Williams et al. 1987). Piping O&M was set at a flat 1.6% of piping direct capital cost (Williams et al. 1987). An equation estimating steam generation O&M as a fraction of direct capital cost and a function of capacity was developed from design point data presented in the APS/PG&E studies. The result was an O&M estimate of 2.2% of the direct capital cost or about \$475,000 per year for a plant with a capacity of 500 MWe. Finally, storage O&M was estimated to be \$0.0074/kWh per year based on estimates prepared by CBI Industries for two-hot tanks and one-cold tank (DOE 1988b).

5.4 LEVELIZED ENERGY COST ESTIMATES

Initial capital cost, annual O&M costs, and annual performance characteristics were combined with the economic methodology and assumptions to produce levelized energy cost (LEC) estimates. These estimates were prepared for the six power plant configurations and planned generating schedules identified in Table 5.8. Levelized energy cost estimates were prepared for one conventional coal-fired plant and two coal-fired power plants with molten salt TES. The LECs for the alternative coal-fired plant with molten salt TES represent different assumptions for plant construction period. The LEC results are presented in Table 5.9.

The results show the coal-fired plant with molten salt TES has an LEC lower than the corresponding conventional coal-fired plant for all of the plant configurations/generation schedules evaluated. The concept using coal-fired plants with molten salt TES looks the most attractive at lower plant capacity

TABLE 5.8. Power Plant Configurations

Generating Schedule days/week hours/day		Coal Plant		Coal/TES Plant	
		Coal-Firing Capacity, MWe	Power-Generation Capacity, MWe	Coal-Firing Capacity, MWe	Power-Generation Capacity, MWe
5	8	500	500	167	500
5	12	500	500	250	500
5	16	500	500	333	500
7	6	500	500	125	500
7	9	500	500	188	500
7	12	500	500	250	500

(a) The coal-firing capacity is the base load electric power that could be generated using the installed coal-firing equipment.

TABLE 5.9. Levelized Energy Cost Results
(mid-1987 levelized \$/kWh)

Generating Schedule days/week hours/day		Coal Plant	Coal/TES Plants	
			4-Year Construction	3-Year Construction
5	8	0.146	0.120	0.118
5	12	0.106	0.097	0.095
5	16	0.086	0.083	0.082
7	6	0.140	0.108	0.107
7	9	0.102	0.088	0.087
7	12	0.083	0.076	0.075

factors (fewer operating hours per day) where the coal-firing equipment is downsized the most and, hence, the benefit of incorporating TES is the greatest. The plant construction period does not have a strong influence on LEC over the range of uncertainty investigated (3 or 4 years).

The key factors contributing to the reduction in LEC for the coal-fired plant with molten salt TES are an increase in plant availability and a decrease in initial capital cost. Initial costs, annually recurring costs, availability, annual power output, and LEC are compared in Table 5.10 for a plant operating 5 days per week and 12 hours per day. Initial capital costs have decreased by \$45 million as reductions in coal handling, emissions handling, and balance-of-plant costs and elimination of the boiler exceed the additional costs of the salt systems. Fuel costs increase for the coal-fired plant with molten salt TES in proportion to the 7% increase in plant

TABLE 5.10. Summary Cost and Performance Comparison: Conventional Coal Versus Coal/TES

Plant Generation Schedule: 5 days/week; 12 hours/day
(all costs in millions of mid-1987 dollars, except LEC)

<u>Initial Capital</u>	<u>Conventional Coal Plant</u>	<u>Coal/TES Plant</u>
coal-firing	411	150
salt systems	-	236
power generation	202	202
balance-of-plant	149	130
other	29	28
total	791	746
<u>Annual O&M</u>		
fuel	17.0	18.1
non-fuel	19.4	19.1
total	36.4	37.2
<u>Annual Availability</u>	0.712	0.759
<u>Annual Energy Output, GWhe</u>	1111	1184
<u>Levelized Energy Cost, \$/kWh</u>	0.106	0.097

availability. Non-fuel O&M costs are greater for the coal plant because additional maintenance associated with the salt systems is less than the decrease in non-fuel O&M associated with the conventional parts of the plant. Overall, the LEC for the coal-fired plant with molten salt TES is about 8% less than the coal plant. If the coal-fired plant with molten salt TES had the same availability as the coal plant, much of its advantage would be lost as its LEC would rise to \$0.102/kWh. Plant designs associated with other plant generation schedules would show some differences. At lower capacity factors, the impact of capital cost reduction associated with reducing the size of the coal-firing equipment would become more important.

Although the levelized energy cost estimates indicate promise for the coal-fired plant with molten salt TES, the results should be used with caution. A considerable amount of uncertainty is associated with many of the key inputs to the analysis. The level of uncertainty is probably highest for plant availability. Other high-impact factors, such as the costs for the salt heater and downsized conventional coal plant equipment, also have a large level of uncertainty. Future efforts should be directed toward improving our understanding of these factors and narrowing the range of uncertainty for individual elements and the overall comparison.

6.0 OTHER CHARACTERISTICS OF UTILITY THERMAL ENERGY STORAGE

This study focused on a comparison of a coal-fired power plant using TES with a conventional cycling coal-fired power plant. The two concepts used currently available pulverized coal combustion technology and the comparison was based on the levelized cost of electricity. Possible applications of thermal energy storage in utility power generation extend beyond conventional coal combustion technologies to advanced concepts, such as fluidized bed combustion and gasification combined-cycle options. In addition, the use of thermal energy storage can have other benefits that were not captured in the cost comparison. These may include options for phased construction and operational flexibility. Finally, the development of nitrate salt TES systems continues and the possibility for additional cost reductions exists. While a detailed evaluation of these topics was beyond the scope of this study, it is still important that they be documented. In Section 6.1, the potential for phased and modular construction is considered. Section 6.2 discusses the potential for flexible operation, while Section 6.3 describes possible applications with emerging clean coal combustion technologies. Section 6.4 presents the potential for cost and performance improvements in the molten salt storage subsystem and Section 6.5 discusses the status of outstanding issues pertaining to molten salt handling.

6.1 POTENTIAL FOR MODULAR CONSTRUCTION

The use of small (200 Mwt to 400 Mwt) modular salt heaters for charging storage would allow the phased construction of a power plant with variable operating characteristics. Figure 6.1 presents a schematic arrangement of such a plant.

The modular plant arrangement would have a number of advantages including:

- higher plant availability - The plant shown in Figure 6.1 could continue to operate if an individual salt heater, steam generator, or steam turbine was out of service for maintenance. The loss of a salt heater would result in a reduced capacity factor but generating capacity would not be affected. The loss of a steam generator or steam turbine would result in reduced capacity but the capacity factor would not be decreased.

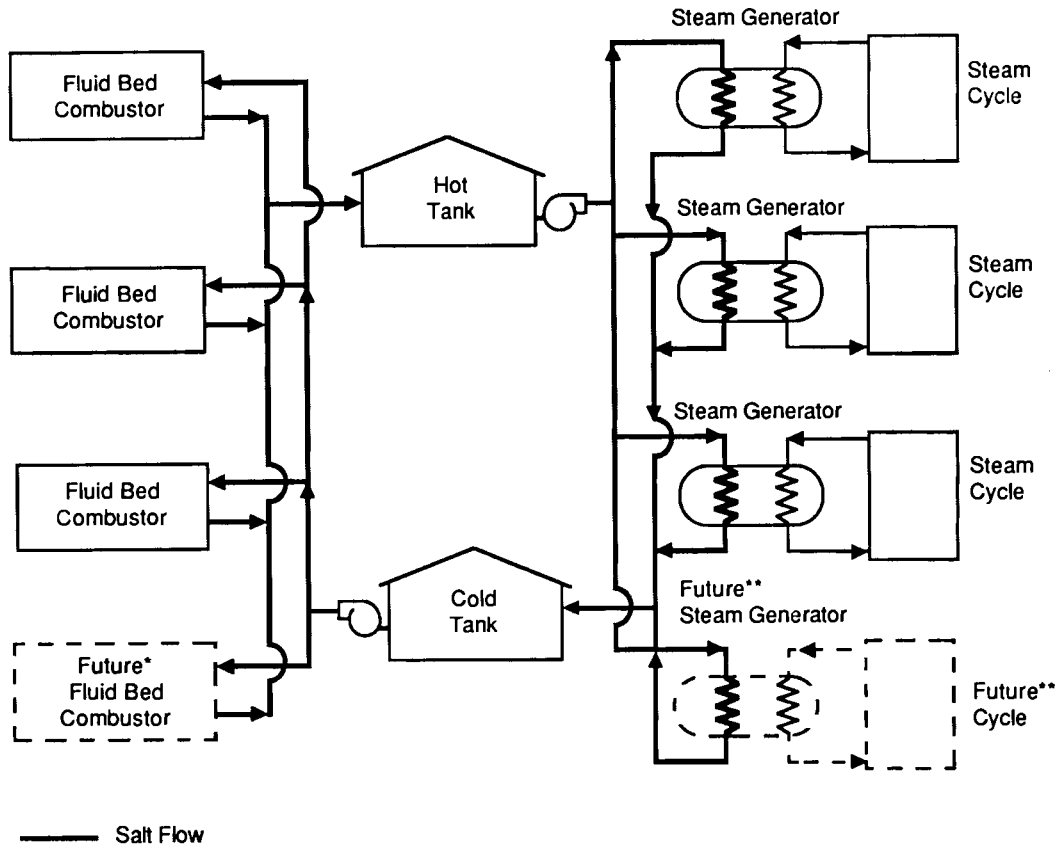

* Added if increased capacity factor is required

** Added if increased peak/intermediate load generating capacity is required

FIGURE 6.1. Arrangement of a Modular Coal-Fired Power Plant Using Molten Salt Thermal Energy Storage

- phased construction - A plant would initially consist of one or more salt heaters, steam generators, and turbines. If additional peaking capacity is required, a new turbine could be added to increase the peak capacity but decrease the capacity factor. If additional base load capacity is required, additional salt heaters could be added, increasing the capacity factor.
- enhancement of advanced coal combustion technologies - The major disadvantage of the modular approach is that the use of small coal-fired salt heaters will result in poor performance and cost when compared to larger sizes. Fluidized bed combustion systems are currently being tested in the size range of interest for the modular plant design and several fluidized bed combustion technologies currently have upper limits on the size of an individual unit (Quinto 1988). If limitations on the maximum size of a single fluidized bed combustion unit already require the use of multiple fluidized bed combustors for salt heating, the modular plant concept may be a cost-effective way to use these designs.

The modular approach allowed by the use of TES appears to have significant advantages and may allow a utility to initially install a small plant that subsequently can be expanded and modified to meet the utility's power generation needs.

6.2 POTENTIAL FOR FLEXIBLE OPERATION

The use of TES allows the continuous warming of the steam generator and turbine, keeping these components at a temperature near their operating temperature. This can permit the rapid startup of the steam turbine assuming that the power plant includes provisions to deal with silica buildup after major reductions in load. The ability to rapidly start up the plant may allow a plant with TES to meet some elements of a utility system's dynamic operating requirements.

A recent evaluation of the impact of system-wide energy storage on meeting a utility's dynamic operating requirements showed that system-wide energy storage can alleviate dynamic operating costs in a number of ways. In some cases, the dynamic operating benefits of system-wide storage can represent between 20% and 60% of the storage plant's total operating cost. A coal-fired power plant with TES does not provide system-wide storage because the TES system cannot be charged with electrical energy from the utility system but it may have several dynamic operating benefits. The benefits associated with reducing dynamic operating costs are dependent on the characteristics of the utility system and their evaluation was beyond the scope of this study. Therefore, no economic credit was taken for reductions in dynamic operating costs but future evaluations should consider the impact of a coal-fired TES plant on a utility system's dynamic operating requirements.

6.3 POTENTIAL FOR APPLICATION WITH CLEAN COAL TECHNOLOGY

Advanced coal combustion technologies, such as slagging combustors and bubbling bed and circulating fluidized bed combustion, will benefit from the development of TES for utility power generation applications. In all cases, the use of a TES system will allow the advanced coal combustion technology to meet intermediate and peak loads without having to cycle the coal combustion equipment.

The combination of a molten salt TES with fluidized bed combustion is attractive because of the modular design of many fluidized bed combustion concepts. This would allow the phased construction of a plant with variable operating characteristics as described in Section 6.1. The design evaluation discussed in Section 4 showed that the average heat transfer characteristics of molten nitrate salt are sufficiently close to those of steam, assuming the development of a successful fluidized bed combustor for salt heating.

The integration of a TES system in a gasification combined-cycle plant also offers a number of advantages. Figure 6.2 shows one possible arrangement. The TES system is charged by thermal energy from the gas turbine exhaust and waste heat from the gasifier. The TES provides thermal energy for the generation of steam for the steam turbine and for process applications. This arrangement would have several attractive features including the following:

- double the plant output at peak demand - The gasifier and gas turbines can be operated continuously, producing base load power, but the thermal energy from the gas turbine exhaust and the gasifier can be stored until peak demand periods when it would be used to generate steam for the steam power cycle. This would approximately double the plant's output for an 8-hour peak demand period.
- improve flexibility and controllability - The addition of a TES would allow the generation of process steam even during time periods when the gas turbine and steam turbine are not operating. The decoupling of steam production from power generation would probably improve the overall flexibility and controllability of the plant.
- reduce cost of salt heater - If the exhaust from the gas turbine is sufficiently clean, the molten salt can be heated in a direct-contact heat exchanger, reducing the cost of the salt heater.

The use of TES in a coal-fired power plant has been shown to be attractive for pulverized coal-firing technology, because it allows a coal-fired plant to economically produce intermediate load power. But applications using TES with advanced coal combustion technologies may be more important. The concept is attractive for applications with advanced coal combustion technologies, and may in fact be the key to using these technologies to provide economical intermediate and base load power generation.

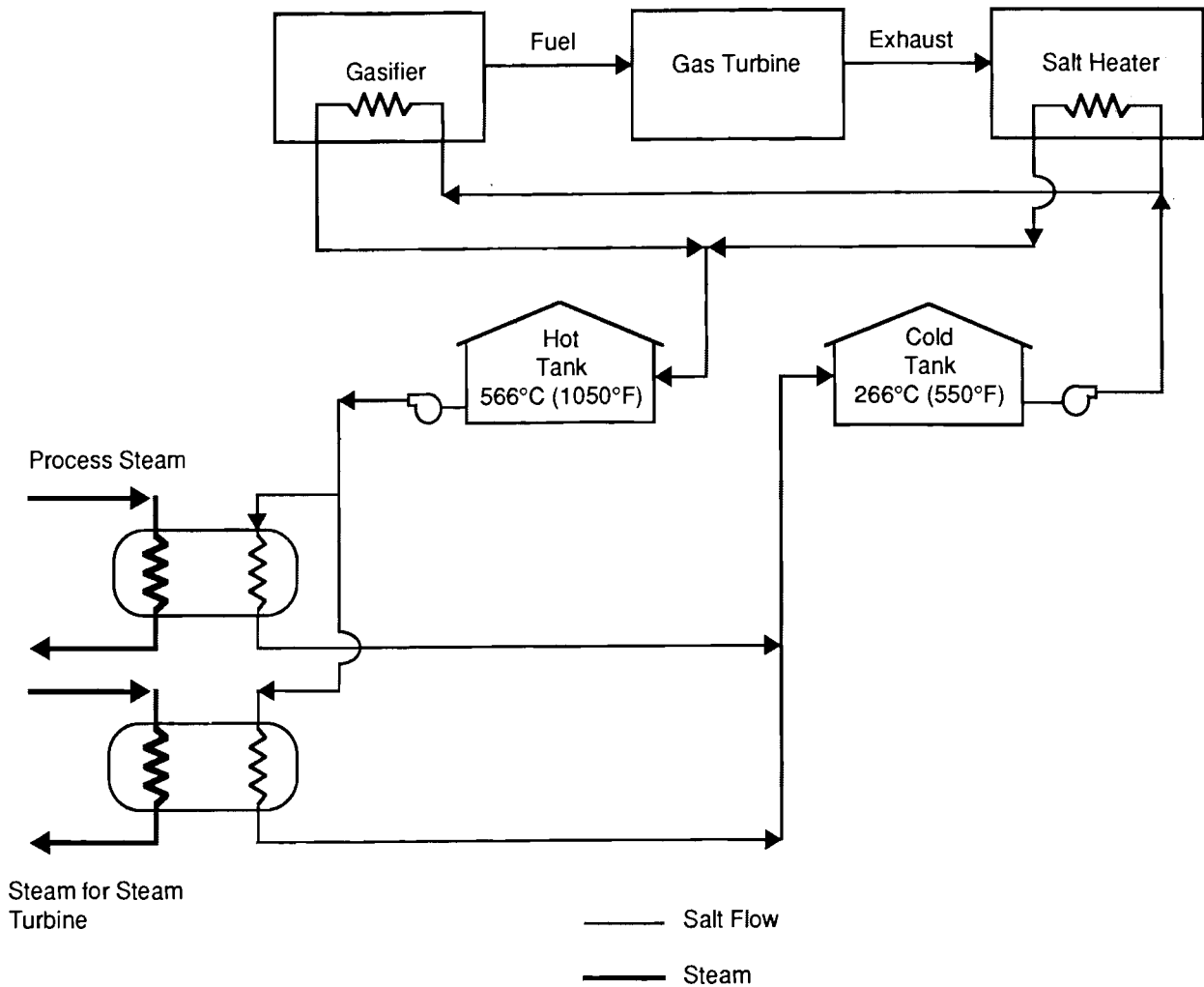

FIGURE 6.2. Arrangement of a Coal Gasification Combined-Cycle Power Plant with Molten Salt Thermal Energy Storage

6.4 MOLTEN SALT THERMAL ENERGY STORAGE TECHNOLOGY DEVELOPMENTS

Molten salt TES has the potential for substantial improvements in cost and performance. Two approaches have been proposed to improve the cost effectiveness of molten salt TES. The first approach involves innovative design of the high-temperature storage tank, while the second approach involves the investigation of alternative molten salts.

The hot salt storage tank is a major cost component and the recent molten nitrate salt TES design study conducted as part of the solar thermal utility study suggested that additional research on the design of the insulation system for the high-temperature tank was desirable (DOE 1988b). The Solar Energy Research Institute has investigated the feasibility of a conical hot salt tank and concluded that it has the potential to substantially reduce the cost of the hot salt storage tank (Kohl, Newcomb, and Castle 1987).

Alternative molten salts may be less expensive than the current nitrate salt and might have a lower freezing temperature. The lower freezing temperature reduces the need for heat tracing molten salt components and can decrease the cost of the TES subsystem by decreasing the amount of salt needed for storage. This results in a reduction in the salt inventory, the size of the storage tanks, the size of piping, and parasitic power requirements associated with moving the molten salt. Alternative molten salts have been investigated for solar applications and the results are promising, though a number of practical issues must be resolved (Bradshaw and Tyner 1988).

While the evaluation of these alternatives was beyond the scope of this study, they do offer the promise of further performance and cost improvements for molten salt TES.

6.5 SALT HANDLING ISSUES

Molten nitrate salt TES has been extensively investigated and has been the subject of several demonstrations (see Appendix). The results indicated that molten nitrate salt TES is technically feasible but problems related to freeze protection and component reliability need to be resolved.

A variety of molten salts have been considered for TES systems. The freezing points for these salts range between 185°C and 285°C (365°F to 545°F). In all cases, the salts freeze at temperatures well above ambient. This can create a problem when a component is out of service because the salt will cool and eventually freeze. During extended outages, molten salt systems can be drained from exposed components but short-term outages require heat tracing to avoid local salt freezing. While heat tracing is a well established

technology, the systems must be carefully installed to avoid component outages caused by salt freezing.

Pumps and valves associated with salt transport have also proved to be problems. Sandia National Laboratories is currently conducting a technology development program in molten salt handling and the balance of expert opinion is that the problems can be solved (DOE 1988a).

7.0 CONCLUSIONS AND RECOMMENDATIONS

The results of this study have led to a number of conclusions and suggestions for further research. Section 7.1 presents a summary of the conclusions while Section 7.2 describes research needs associated with utility TES.

7.1 CONCLUSIONS

The significant conclusions from this evaluation of TES for utility power generation are summarized below.

- Molten Nitrate Salt TES is Technically Feasible - While acknowledging that problems exist with certain aspects of salt handling, these appear to be resolvable. The overall judgement, both of this study and similar evaluations in the solar thermal area, is that molten nitrate salt TES is technically feasible and it is reasonable to assume that the technology can be successfully commercialized.
- Using TES in a Conventional Coal-Fired Power Plant Produces Lower Cost Power - The results of this study show that a coal-fired power plant with molten salt TES produces lower cost power than a conventional cycling coal plant over a range of operating schedules, but substantial uncertainties exist in several key inputs to the levelized energy costs.
- Molten Salt TES May Enhance Advanced Coal Combustion Technologies - The use of TES with advanced coal combustion technologies, such as a coal gasification combined-cycle plant and fluidized bed combustion, improves the flexibility of these technologies by letting them provide peak and intermediate load power. If technically feasible, direct-contact salt heating would be particularly attractive for applications with coal gasification combined-cycle plants.

7.2 RESEARCH NEEDS

The results of this study show that thermal energy storage has substantial promise when used in coal-fired power plants but to advance the technology additional research is needed, as described below.

- Resolve Remaining Technical Issues Associated With Molten Salt TES - The remaining technical issues associated with molten salt handling need to be resolved and demonstrated in field tests.
- Conduct a More Detailed Evaluation of Using Molten Salt With Pulverized Coal Technology - The evaluation documented in this report was a scoping study and could not address second-order issues. Before proceeding with a technology development program, a more detailed evaluation should be conducted. This evaluation should include a vendor-developed design and cost estimate for the coal-fired salt heater and should explicitly consider options for modular and phased construction.
- Evaluate the Economic and Technical Feasibility of Using Molten Salt TES with Advanced Coal Combustion Technologies - Advanced coal combustion technologies, such as coal gasification combined-cycle plants and fluidized bed combustion, should be reviewed for TES applications. Attractive applications should be identified and evaluated to determine the technical feasibility of the application, key design features, and potential costs. Direct-contact salt heating should be investigated because of its potential to dramatically reduce the cost of the salt heater.
- Conduct a Large-Scale Field Test of a Coal-Fired Salt Heater and Thermal Energy Storage - The acceptance of TES technology by the utility industry will depend on a successful large-scale field test of the concept. A meaningful technology development program must result in such a field test.

8.0 REFERENCES

- Babcock and Wilcox. 1978. Steam/Its Generation and Use. The Babcock and Wilcox Company, New York, New York.
- Bergan, N. E. 1987. "An External Molten Salt Solar Central Receiver Test." In Proceedings of the ASME-JSME-JSES Solar Energy Conference, eds. D. Y. Goswami, K. Watanabe, and H. M. Healey, pp. 474-476. American Society of Mechanical Engineers, New York, New York.
- Bradshaw, R. W., and C. E. Tyner. 1988. Chemical and Engineering Factors Affecting Solar Central Receiver Applications of Ternary Molten Salts. SAND88-8686, Sandia National Laboratories, Albuquerque, New Mexico.
- Brown, D. R., J. A. Dirks, M. K. Drost, G. E. Spanner, and T. A. Williams. 1987. An Assessment Methodology for Thermal Energy Storage Evaluation. PNL-6372, Pacific Northwest Laboratory, Richland, Washington.
- Carling, R. W. 1983. "Heat Capacities of NaNO_3 and KNO_3 from 350 to 800 K." Thermochimica Acta 60(1983):265-275.
- Data Resources, Inc. 1988. 1988 Energy Review. Data Resources, Inc., Lexington, Massachusetts.
- De Laquil III, P., B. D. Kelly, and J. C. Egan. 1988. Solar Central Receiver Technology Advancement for Electric Utility Applications. Report No. 007.2-88.2, Vols. I and II, Bechtel National Inc., San Francisco, California.
- Delameter, W. R. 1987. "The Molten Salt Electric Experiment: a Project Overview." In Proceedings of the ASME-JSME-JSES Solar Energy Conference, eds. D. Y. Goswami, K. Watanabe, and H. M. Healey, pp. 468-478. The American Society of Mechanical Engineers, New York, New York.
- DOE. 1988a. Alternate Utility Team Utility Solar Central Receiver Study. Report no. DOE/AL/38741-2, Vols. 1 and 2, U.S. Department of Energy, Washington, D.C.
- DOE. 1988b. Arizona Public Service Utility Solar Central Receiver Study. Report no. DOE/AL/37841-1, Vols. 1 and 2, U.S. Department of Energy, Washington, D.C.
- Electric Power Research Institute. 1986a. Technical Assessment Guide. EPRI P-4463-SR, Palo Alto, California.
- Electric Power Research Institute. 1986b. Capital Cost Estimates and Schedules for Coal-Fired Power Plants. EPRI P-4542, Palo Alto, California.
- Energy Information Administration. 1988a. Annual Energy Outlook 1987 With Projections to 2000. U.S. Department of Energy, Washington, D.C.

- Energy Information Administration. 1988b. Historical Plant Cost and Annual Production Expenses for Selected Electric Plants, 1986. DOE/EIA-0455 (1986), U.S. Department of Energy, Washington, D.C.
- General Electric Co. 1979a. Conceptual Design of Thermal Energy Storage Systems for Near-Term Electric Utility Applications. Volume 1: Screening of Concepts. EPRI EM-1037, Vol. 1, Electric Power Research Institute, Palo Alto, California.
- General Electric Co. 1979b. Conceptual Design of Thermal Energy Storage Systems for Near-Term Electric Utility Applications. Volume 2: Appendixes - Screening of Concepts. EPRI EM-1037, Vol. 2, Electric Power Research Institute, Palo Alto, California.
- General Electric Co. 1979c. Combined Thermal Storage and Transport for Utility Applications. EPRI EM-1175, Electric Power Research Institute, Palo Alto, California.
- Guthrie, K. M. 1974. Process Plant Estimating, Evaluation, and Control. Craftsman Book Company of America, Solana Beach, California.
- Holtberg, P. D., T. J. Woods, and A. B. Ashby. 1987. 1987 GRI Baseline Projection of U.S. Energy Supply and Demand to 2010. Gas Research Institute, Chicago, Illinois.
- Kays, W. M., and A. L. London. 1964. Compact Heat Exchangers. McGraw-Hill, New York, New York.
- Kohl, A. L., J. C. Newcomb, and W. R. Castle. 1987. Evaluation of a Conical Tank for High Temperature Molten Salt Containment. SERI/STR-231-3193, Solar Energy Research Institute, Golden, Colorado.
- Kolb, G. J., and U. Nikolai. 1988. Performance Evaluation of Molten Salt Thermal Storage Systems. SAND87-3002, Sandia National Laboratories, Albuquerque, New Mexico.
- Kreith, F., and M. S. Bohn. 1986. Principles of Heat Transfer. 4th ed. Harper and Row, New York, New York.
- Mahoney, W. D. 1986. Means Construction Cost Data 1986. R. S. Means Company, Kingstone, Massachusetts.
- Martin Marietta Corporation. 1978. Conceptual Design of Advanced Central Receiver Power System. DOE/ET/20314-1/2, National Technical Information Service, Springfield, Virginia.
- Martin Marietta Corporation. 1984. Alternate Central Receiver Power System, Phase II Volume II-Molten Salt Receiver. SAND81-8192/2, Sandia National Laboratories, Albuquerque, New Mexico.

Martin Marietta Corporation. 1985. Volume 1 - Molten Salt Thermal Energy Storage Subsystem Research Experiment. SAND80-8192, Sandia National Laboratories, Albuquerque, New Mexico.

Power. June 1988. "Utility Boilers." 132(6):43-44.

Quinto. 1988. "A Comparison of Bubbling and Circulating Fluid Bed Technology." In Repowering America, Proceedings of the XV Energy Technology Conference. Government Institute, Rockville, Maryland.

Ross, K., J. Roland, and J. Bouma. 1982. Solar 100 Conceptual Study. Southern California Edison, Los Angeles, California.

Sorensen, H. A. 1983. Energy Conversion Systems. John Wiley and Sons, New York, New York.

Stevenson, J. J., and P. H. Walker. 1987. "Power Plant Economy of Scale-Revisited." In 1987 Transactions of the American Association of Cost Engineers. American Association of Cost Engineers, Morgantown, West Virginia.

United Engineers & Constructors, Inc. 1987. Energy Economic Data Base Program Technical Reference Book. UE&C-ORNL-870615, United Engineers & Constructors, Philadelphia, Pennsylvania.

United Engineers & Constructors, Inc. 1988. Energy Economic Data Base Program Phase IX (1987) Report. UE&C-ORNL-880331, United Engineers & Constructors, Philadelphia, Pennsylvania.

United States Energy Association. 1988. U.S. Energy'88: Countdown to the Next Crisis, Second Annual Assessment of U.S. Energy Policy and Prospects. U.S. Energy Association, U.S. Member - Committee of the World Energy Conference, April 1988.

Weber, E. R. 1980. Saguaro Power Plant Solar Repowering Project. DOE/SF/10739-1, Arizona Public Service Company, Phoenix, Arizona.

Wharton Econometric Forecasting Associates. 1987. 1987 Energy Analysis Quarterly. Wharton Econometric Forecasting Associates, Bala Cynwyd, Pennsylvania.

Williams, T. A., J. A. Dirks, D. R. Brown, M. K. Drost, Z. I. Antoniak, and B. A. Ross. 1987. Characterization of Solar Thermal Concepts for Electricity Generation. Volume 1 - Analyses and Evaluation. PNL-6128, Vol. 1, Pacific Northwest Laboratory, Richland, Washington.

APPENDIX

FEASIBILITY AND TECHNICAL STATUS OF USING MOLTEN NITRATE SALT
FOR ENERGY STORAGE

APPENDIX

FEASIBILITY AND TECHNICAL STATUS OF USING MOLTEN NITRATE SALT FOR ENERGY STORAGE

A.1 INTRODUCTION

The feasibility and technical status of the nitrate salt (60% NaNO_3 , 40% KNO_3 by weight) for application in a thermal energy storage (TES) system that can be integrated into a utility power plant was examined. The literature was reviewed to determine 1) nitrate salt physical, chemical, and mechanical properties; 2) availability of technology for using the salt in TES applications; and 3) the problems encountered in previous applications of nitrate salts for TES. This review concludes that the use of the nitrate salt is both technically feasible and economical for high-temperature TES systems that can either be used in conjunction with base load conventional power plants or in industrial process heat applications.

A.2 NITRATE SALT

Molten nitrate salts have received considerable attention in the solar community because they have the potential to serve as a medium for both heat transfer and thermal energy storage (Battleson et al. 1980; Battleson 1981; Carling and Bradshaw 1986). Nitrate salts have been used for years as a high-temperature heat transfer medium in the chemical and metal industries. Typical industrial experience, plant performance, and plant history have been documented by Carling and Mar (1981). Industrial experience was limited to temperatures around 450°C (842°F). However, for either electrical power generation or high-temperature industrial process heat applications, the TES systems require higher operating temperatures [up to 600°C (1110°F)]. Nitrate salt is an excellent sensible heat storage medium because it has a high heat capacity per unit volume, low vapor pressure, and good heat transfer properties. The nitrate salt mixture has a low melting point [eutectic at 222°C (432°F)]. Its abundant availability at low cost and the minimal hazards associated with its use make it more attractive for TES application.

Sandia National Laboratories established a comprehensive research program to address the issues related to the use of molten nitrate salts at high temperatures. Sandia's research efforts included studies of physical properties, thermochemical stability, corrosion/erosion of the containment materials, mechanical behavior of metals and alloys in salt contact, and the effect of salt on component selection (Carling 1983). Chemical stability of nitrate salts was experimentally proven and supported by thermodynamic modeling to be more than adequate at temperatures up to 600°C (1110°F) (Carling and Bradshaw 1986). Higher temperatures should be avoided because decomposition and corrosion become serious.

For fabrication of the components of the system, materials such as Incoloy 800, 300 series stainless steels, and 9Cr-1Mo offer good corrosion resistance at temperatures to 600°C (1110°F) (Carling and Bradshaw 1986). Deposition of dissolved chromium due to thermal gradients does not appear to be a problem. However, corrosion allowances of up to 0.1 mm/yr must be used for 2-1/4Cr-1Mo even at 460°C (860°F). Although protective surface scale layers were generally adherent, no testing was performed under thermal cycling conditions, which represents the major deficiency in materials behavior data. The study performed for advanced solar central receiver (SCR) systems that operate at temperatures up to 600°C (1110°F), concludes that the use of molten nitrate salt is technically feasible and a very attractive candidate for TES applications (Carling and Bradshaw 1986).

A.3 THERMAL ENERGY STORAGE

Thermal energy storage is required to match the availability of energy to the time of energy demand. Several TES systems were examined by Hausz, Berkowitz, and Hare (1978).

A.3.1 Storage Tank Configuration

To advance the state-of-the-art in the high-temperature containment of molten salt, Martin Marietta Corporation (1985a) has conducted a molten salt Thermal Energy Storage Experimental Program. Two generic types of storage

tank designs were considered: a two-tank system with one tank for the hot fluid and a second for the cold fluid; and a single-tank thermocline system, where the density difference between the hot and cold fluids inhibits convective mixing and heat transfer. Thermocline storage has been proven technically feasible for lower temperature systems (Copeland and Green 1983). However, at higher temperatures, the radiant heat transfer becomes dominant because a natural thermocline of a liquid, transparent in infrared wavelength, provides no radiant transfer resistance.

The major advantage of the two-tank system over the single-tank system is that the hot and cold fluids do not come in contact or exchange heat with each other. On the other hand, two separate, equal-volume tanks are required, and the sidewalls of both tanks are subjected to frequent pressure cycles, alternating between contact and no contact with molten salt. However, the thermal cycling is not nearly as severe as in the thermocline concept. Also the cost of the cold tank is approximately one-fifth the cost of the hot tank (Martin Marietta Corporation 1985a). Therefore, the potential cost disadvantage for dual tanks is minimal, while the concept provides added flexibility.

A.3.2 Subsystem Research Experiment (SRE)

The SRE was designed, fabricated, and tested using a subscale prototype molten salt TES system (Martin Marietta Corporation 1985a) employing the dual tank concept. The SRE subscale storage tanks were designed and constructed using the same techniques that would be used for a full-scale TES system (e.g., full-size panels with welds and attachments to the rest of the tank, full-size insulation thickness, water-cooled concrete foundations). Solar heating of the salt in a commercial plant was simulated by using a fossil-fired heater; cooling of the salt associated with generating steam for the commercial plant was simulated by using an air cooler. The SRE was tested in all the operational modes employed by a full-size plant. Thus, the SRE simulated all aspects of the design, construction, and operation of the TES system for a full-scale plant, only on a smaller scale.

The SRE design (Martin Marietta Corporation 1985a) is shown schematically in Figure A.1.

- one internally and externally insulated hot tank, 7.2-m (23.6-ft) high and 3.7 m (12.3 ft) in shell diameter, with a Technigaz Incoloy 800 liner and a carbon steel shell
- one externally insulated cold tank, 3.7-m (12-ft) high and 3.7 m (12.3 ft) in shell diameter, with a carbon steel shell
- operating temperatures of 566°C (1050°F) in the hot tank and 266°C (550°F) in the cold tank
- thermal storage capacity of 6.9 MWht (2.35×10^7 Btu)
- a safety dike surrounding each tank
- one fossil-fired heater with a 3 MWt (10.4×10^6 Btu/h) salt heating capacity
- one air cooler of 5 MWt (17×10^6 Btu/h) salt heating capacity
- one hot sump with a 5.6-kW (7.5-hp) cantilever pump
- one cold sump with a 44.7-kW (60-hp) cantilever pump
- 79,400 kg (175,000 lb) of 60% sodium nitrate/40% potassium nitrate molten salt
- all necessary piping and valves, all with electrical trace heating
- a semiautomatic control system
- temperature, pressure, and fill level instrumentation at key points throughout the system.

The hot salt storage tank was the principal element of the SRE system. Figure A.2 shows the elements of the hot and cold tank design for the SRE.

The shell of the hot tank was made of carbon steel (SA516 grade 70). The thickness was sized to keep the hoop stress in the shell walls at the same safe working level as in the full-scale TES system and in conformance with all applicable codes. The internal insulation on the walls and the floor was refractory brick. A fibrous internal insulation was selected for the ceiling because it carried no pressure loads and was inexpensive.

A.5

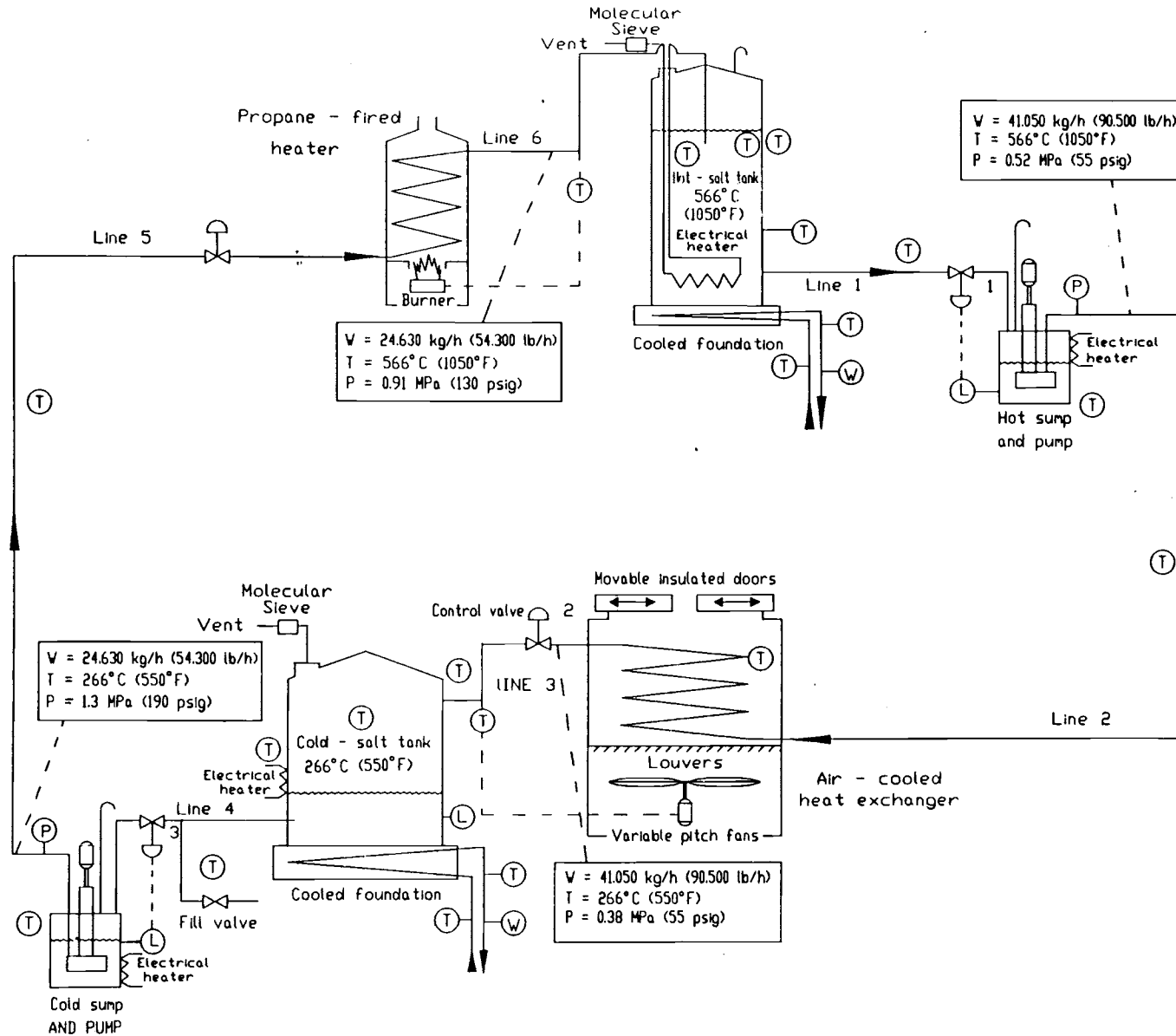
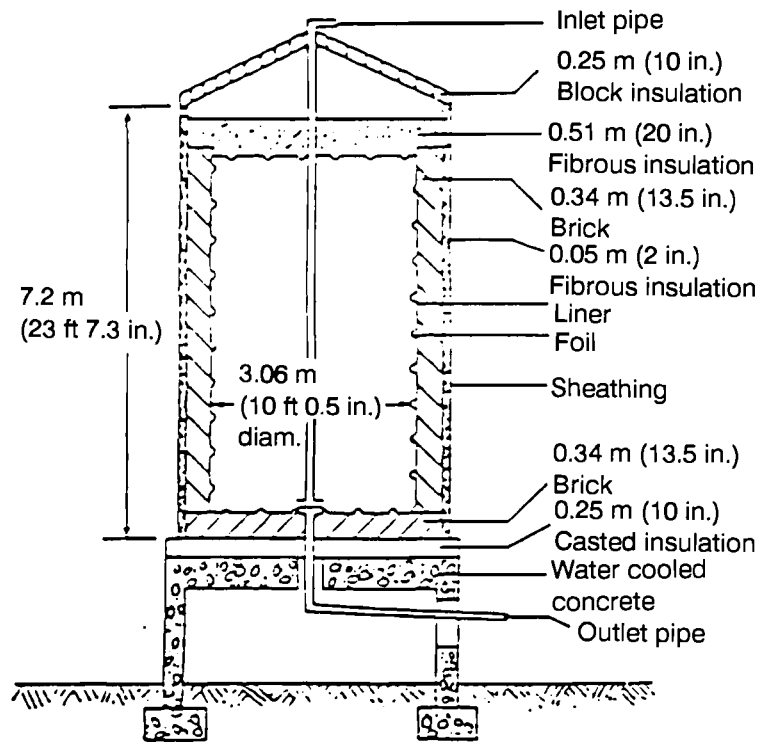
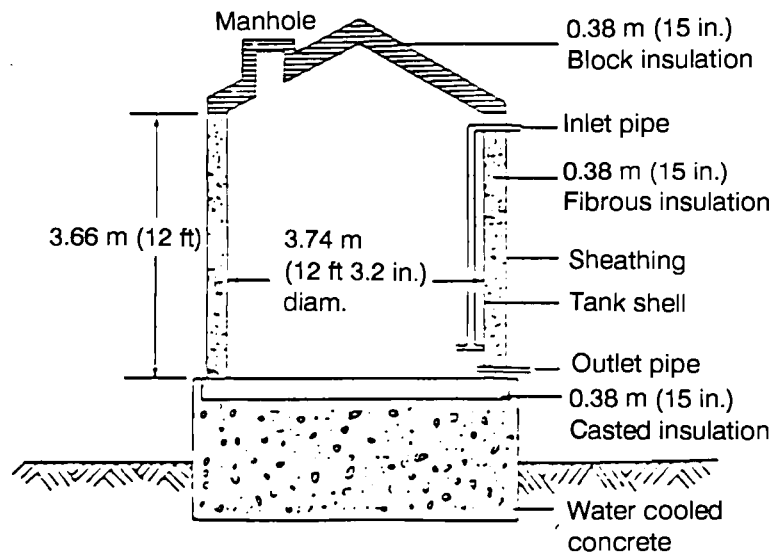

FIGURE A.1. Subsystem Research Experiment Flow Schematic



SRE Hot Tank



SRE Cold Tank

FIGURE A.2. Subsystem Research Experiment Hot and Cold Tanks (Tracey, Scott, and Goodman 1986)

External fibrous insulation was protected from the weather by aluminum sheathing. Internal and external insulation was provided to keep the bottom shell temperature the same as the sidewall shell temperature.

A.3.2.1 Subsystem Research Experiment Test Results

The operation and performance of the subscale research experiment demonstrated that a TES system using molten nitrate salt could operate efficiently, reliably, and safely in both steady-state and transient modes, representative of what would be experienced in a large power plant.

The thermal performance (actual heat loss) testing of the system included the hot tank, cold tank, cyclic test with comparison to analytical models, and thermal syphon heat transfer in lines. The thermal performance of all the support equipment (sumps, lines, air cooler) was as predicted. Support equipment was provided with heat tracing. The actual heat loss values for the hot and cold salt storage tanks are compared to the calculated heat loss values in Table A.1. The hot tank actual heat loss was within 11% of the calculated heat loss. The comparison of the cold tank actual heat loss to the calculated heat loss shows the actual heat loss to be 63% higher. This is assumed to be caused by absorption of water vapor emitted from curing of the casted insulation by the external insulation. This condition not only changed the thermal conductivity of the insulating material but also could result in a wicking heat pipe effect in the fibrous insulation, which would further degrade performance. It is believed that the casted insulation can be adequately cured before it is placed in cold tank construction. More recent testing of the SRE with dry insulation showed significantly lower heat loss from the cold tank (Kolb and Nikolai 1988).

The SRE test results have shown that the molten nitrate salt high-temperature storage using a cylindrical, internally insulated hot tank is both technically and economically feasible.

A.4 MOLTEN SALT ELECTRIC EXPERIMENT

Individual subsystems of a molten salt solar power plant have been tested since 1980. But in the molten salt electric experiment (MSEE), these subsystems were operated as part of a solar power plant. The MSEE was built and

TABLE A.1. Storage Tank Heat Losses (Tracey, Scott, and Goodman 1986)

Hot Tank	Calculated Loss		Actual Loss	
	W	Btu/h	W	Btu/h
Attic	578	1974	1155	3944
Upper ins. support ring	91	312	133	454
Penetration	88	300	88	300
Upper wall	920	3139	786	2683
Wall	13877	47363	15328	52314
Lower ring and edge	352	1200	380	1296
Foundation	1573	5367	1486	5073
Total	17479	59655	19398	66226

Actual/calculated = 1.11. The salt temperature was 508°C (947°F). Penetration losses were taken as calculated values.

Hot Tank	Calculated Loss		Actual Loss	
	W	Btu/h	W	Btu/h
Penetrations	267	910	267	910
Heaters	766	2614	766	2614
Upper ring	74	252	359	1223
Tank top	875	2986	1305	4393
Lower ring	480	1638	527	1770
Foundation	1478	5046	1529	5190
Wall	2835	9675	6400	21563
Total	6774	23121	11153	37663

Actual/calculated = 1.63. The salt temperature was 388°C (641°F). Penetration and heater losses were taken as calculated values.

tested to demonstrate the technical feasibility of the molten salt central receiver system and to provide performance information and operating experience on molten salt systems and components (Delameter and Berger 1986).

A.4.1 MSEE System

The MSEE has five major subsystems: the receiver, the thermal storage unit, the steam generator, the electric power generator, and the master controller (Martin Marietta Corporation 1985b). The solar central receiver heats

the molten salt from 310°C to 566°C (590°F to 1050°F) (Martin Marietta Corporation 1981). The salt flows up and down through 18 vertical tube passes. Each pass consists of 16 0.19-m (0.75-in.) Incoloy 800 tubes. A salt flow of 12.2 kg/s (97,000 lb/h) is required for the full-rated capacity of 5 MWt. The peak solar flux is 600 kWt/m² (190,000 Btu/ft²-h).

The thermal storage unit consisted of two large tanks: one to store "hot" salt at 566°C (1050°F) and one for the 310°C (590°F) "cold" salt (Wells and Nassopoulos 1981). Salt is pumped from the cold tank up through the receiver and down to the hot tank. Salt from the hot tank is pumped to the steam generator where superheated steam is produced to drive a turbine-generator. The thermal storage system has a capacity of about 7 MWh when fully charged, enough to supply the steam generator at rated conditions for slightly more than 2 hours.

The steam generator has a superheater, an evaporator, and a steam drum (Babcock and Wilcox 1986). Both heat exchangers use U-tubes with a U-shell design to accommodate differential thermal expansion. At design conditions, the steam generator produces 1.46 kg/s (11,600 lb/h) of steam at 510°C (950°F) and 7.6 MPa (1100 psi) and has a rating of 3.1 MWt.

The turbine generator accepts 0.98 kg/s (7800 lb/h) of steam at 504°C (940°F) and 7.24 MPa (1050 psi) and produces 750 kWe, 460 volts, three-phase alternating current. The steam condenses at 17 kPa (5-in. Hg) and 56°C (133°F) and the waste heat is rejected through dry cooling towers. The power was fed to the local distribution grid.

A.4.2 System Operational Problems

A detailed discussion of the test results was reported by McDonnell Douglas(a). Several problems were encountered during the construction and testing of the MSEE (Delameter and Berger 1986). Major problems were related to heat trace, insulation, instrumentation, pumps, and valves.

(a) McDonnell Douglas. Molten Salt Electric Experiment - Final Report. To be published by EPRI.

A.4.2.1 Heat Tracing and Insulation

In MSEE, electrical trace heaters were used to maintain the heat of components, such as valve actuators and instrumentation, and to preheat piping to avoid thermal shock at system startup. Most heat trace problems were caused by improperly designed or installed heat trace and insulation (Michaels and Mueller 1983).

The original heat trace design philosophy was to match the power density (watts per linear foot of pipe) to the heat loss through the insulation. This "passive control" design did not work. On cold and windy days the temperature of many portions of the piping fell below the freezing point of salt and salt could not be introduced for fear of it freezing. Additional insulation could not be added because the pipes would then overheat on hot days. A better approach is to overdesign the power density and regulate the electric power to the heat trace to control the pipe temperatures.

Gaps in the insulation allowed convective air flow both from the outside and along interior gaps parallel to the pipe, resulting in high heat losses. The design solution is to use soft blanket insulation around complex shapes, such as elbows and valves, and to apply rigid insulation to straight pipe sections. The emphasis of heat trace design should be on reliability rather than initial cost, as this will minimize the overall cost.

A.4.2.2 Instrumentation

The instrumentation problems related to molten salt were caused by either high temperatures, the requirement to keep the salt from freezing, or both.

Pressure transducers were used for both pressure measurements and flow measurements. Pressure transducers must be isolated from salt because of the salt's corrosive nature, but at the same time they must be able to sense pressure variations. This is accomplished with a fluid coupling through a diaphragm or bellows. Problems occurred when the fluid coupling mechanisms overheated or when the temperature was not kept above the freezing point of salt. Solid salt formed within the coupling and the diaphragms or bellows were damaged when actuated.

Another problem was encountered because in-line instrumentation must be removed periodically for recalibration to ensure accurate readings. These instruments can be removed most easily if they are held with flanges in the piping. However, molten salt has a tendency to leak through flanges, and welded joints are preferred. When the in-line instrumentation is welded in place, a routine recalibration requires the welds to be cut for removal, and rewelded for replacement. This had become a time consuming routine maintenance task.

A.4.2.3 Pumps and Valves

The use of commercially available valves and pumps for molten salt applications was a major problem. Valves for the MSEE were specified with bellows seals to prevent external leakage of salt around the actuator stem. Standard valves with packed seals were not used because a packing material that could withstand salt at temperatures of 600°C (1110°F) had not been identified. Bellows seals are commonly used in valve sizes up to 0.10 m (4 in.) for applications involving high temperatures. In spite of this design approach, several salt leaks occurred. These leaks resulted from either operational errors or from hardware that was not consistent with design specifications. Salt leakage also damaged instrumentation, heat trace cables, wiring, and insulation.

A second problem with MSEE valves was internal salt leakage through valves. Internal leakage was particularly troublesome in the isolation valves. These valve problems underscore the need for economical, reliable molten salt valves and for revised system designs that minimize the dependence on valves.

The three molten salt pumps in the MSEE operated with reasonable reliability. Many of the problems were related to two properties of nitrate salts. First the high degree of "wettability" of the liquid results in salt creeping up the impeller shaft into the seals and bearings. Second, the extreme hardness of the salt when frozen makes it very difficult to re-start cold pumps with salt frozen around the impeller shaft seal.

For hot salt applications at 566°C (1050°F), the corrosive nature of the salt dictates a "cantilever pump" design with the bearings out of the salt.

Commercial solar plant requirements will extend the capabilities of existing cantilever pumps and require either the use of multiple pumps staged in series or the use of other types such as the vertical turbine pump. The experience with MSEE salt pumps underscores the need for demonstration of existing pumps or development of new pumps for commercial plants.

A.4.2.4 Parasitic Losses

Parasitic losses for the MSEE were a major contributor to low net performance of the system. High parasitics were due to two factors. First, the MSEE is a relatively small system and thermal losses are a large percentage of the system power rating. Second, the MSEE was not designed to simulate commercial system performance. The experiment contains many inefficient components that greatly increase the parasitic losses.

The net result is that the MSEE parasitic losses were greater than the gross energy output of the system. However, there is nothing in the MSEE test results that indicates that the high efficiencies anticipated for commercial solar power plants cannot be obtained. The TES system efficiency is anticipated to be in the 98% to 99% range (Kolb and Nikolai 1988).

A.5 CONCLUSIONS

The U.S. Department of Energy's Solar Thermal Program's data base includes information on the physical and chemical properties of molten nitrate salt; the effects of the salt on construction materials and components has been established. Chemical stability of nitrate salts has been shown to be more than adequate at temperatures up to 600°C (1110°F), the range of utility and process heat applications. The major conclusion from the work of Sandia is that the use of molten nitrate salt is technically feasible for TES applications (Carl- ing and Bradshaw 1986).

Molten nitrate salt high-temperature storage using a cylindrical internally insulated hot tank is technically feasible. Subsystem research experimental work has shown that such a system can be designed and built with a high degree of confidence. The molten salt electric experiment accomplished its primary goal, the feasibility demonstration of a full central receiver system using molten nitrate salt as a primary working fluid.

Based on these analytical and experimental demonstration successes with molten nitrate salt for high-temperature energy storage applications, it can be concluded that a nitrate salt TES system is technically feasible for non-solar applications, such as in conventional utility power plants used for peak or intermediate power generation or cogeneration.

A.6 REFERENCES

Babcock and Wilcox Co. 1986. Molten Salt Electric Experiment Steam Generator Subsystem. SAND85-8181, Sandia National Laboratories, Livermore, California.

Battleson, K. W. 1981. Solar Power Tower Design Guide, Solar Thermal Central Receiver Power Systems. A Source of Electricity and/or Process Heat. SAND81-8005, Sandia National Laboratories, Livermore, California.

Battleson, K. W., et al. 1980. Solar Central Receiver Technology Evaluation. SAND80-8235, Sandia National Laboratories, Livermore, California.

Carling, R. W. 1983. "Heat Capacities of NaNO_3 and KNO_3 from 350 to 800 K." Thermochimica Acta 60:265-275.

Carling, R. W., and R. W. Bradshaw. 1986. "Review of the Characterization of Molten Nitrate Salt for Solar Central Receiver Applications." In Proceedings of the 21st Intersociety Energy Conversion Engineering Conference, Vol. 2, pp. 834-838. American Chemical Society, Washington, D.C.

Carling, R. W., and R. W. Mar. 1981. Industrial Use of Molten Nitrate/Nitrate Salts. SAND81-8020, Sandia National Laboratories, Livermore, California.

Copeland, R. J., and J. Green. 1983. "Raft Thermocline Thermal Storage." In Proceedings of the 18th Intersociety Energy Conversion Engineering Conference, Vol. 4, pp. 1801-1985. American Institute of Chemical Engineers, New York, New York.

Delameter, W. R., and N. E. Berger. 1986. Review of the Molten Salt Electric Experiment- A Solar Central Receiver Project. SAND86-8249, Sandia National Laboratories, Livermore, California.

Hausz, W., B. J. Berkowitz, and R. C. Hare. 1978. Conceptual Design of Thermal Energy Storage Systems for near Term Electric Utility Applications. Vol. 1: Screening of Concepts; Vol. 2: Appendices- Screening of Concepts. Report GE78TMP-60; Prepared for the U.S. Department of Energy, The National Aeronautics and Space Administration (NASA Report No. CR-159411), and the Electric Power Research Institute (EPRI Report EM-1037, April 1979) by General Electric Co.-TEMPO, Santa Barbara, California.

Kolb, G. J., and U. Nikolai. 1988. Performance Evaluation of Molten Salt Thermal Storage Systems. SAND87-3002, Sandia National Laboratories, Albuquerque, New Mexico.

Martin Marietta Corporation. 1981. Alternate Central Receiver Power Systems. Phase II, Vol. II: Molten Salt Receiver. MCR-81-1707, Martin Marietta Corporation, Denver, Colorado.

Martin Marietta Corporation. 1985a. Molten Salt Thermal Energy Storage Subsystem Research Experiment. SAND 80-8192, Vols. 1 and 2, Sandia National Laboratories, Livermore, California.

Martin Marietta Corporation. 1985b. Molten Salt Electric Experiment (MSEE). Phase I Report. SAND85-8175, (3 Vol.), Sandia National Laboratories, Livermore, California.

Michaels, A. I., and R. O. Mueller. 1983. Thermal Energy Storage in Molten Salt Systems For Solar Central Receivers. ANL/EES-TM-240, Argonne National Laboratory, Argonne, Illinois.

Tracey, T. R., O. L. Scott, and B. Goodman. 1986. "Economical High Temperature Sensible Heat Storage Using Molten Nitrate Salt." In Proceedings of 21st Intersociety Energy Conversion Engineering Conference, Vol. 2, pp 850-855. American Chemical Society, Washington, D.C.

Wells, P. B., and G. P. Nassopoulos. 1981. "Molten Salt Thermal Energy Storage Subsystem for Solar Thermal Central Receiver Plants." In 16th Intersociety Energy Conversion Engineering Conference Proceedings, Vol. 1, pp. 925-930. American Society of Mechanical Engineers, New York, New York.

DISTRIBUTION

No. of
Copies

No. of
Copies

OFFSITE

	U.S. Department of Energy Attn: K. Klein Office of Energy Storage & Dist. Forrestal Bldg, CE-32 5E-036 Washington, DC 20585	Lawrence Berkeley Laboratory Attn: M. Wahlig University of California Bldg. 90-2024 1 Cyclotron Road Berkeley, CA 94720
	U.S. Department of Energy Attn: E. Reimers Office of Energy Storage & Dist. Forrestal Bldg, CE-32 5E-036 Washington, DC 20585	Charles F. Meyer 1141 Cima Linda Lane Santa Barbara, CA 93108
12	DOE/Office of Scientific and Technical Information	National Aeronautics and Space Administration Asst. Adm. for Energy Programs Washington, DC 20585
	District Heating Development Co. Attn: H. Jaehne 76 W. Kellogg Blvd. St. Paul, MN 55102	New York State Energy Research & Development Agency Attn: G. Walmet Rockefeller Plaza Albany, NY 12223
	Electric Power Research Institute Attn: V. Rabl PO Box 10412 Palo Alto, CA 94303	Oak Ridge National Laboratory Attn: M. Taylor Building 9204-1, MS 8045 Y-12 Plant, Box 2009 Oak Ridge, TN 37831-8045
	Electric Power Research Institute Attn: R. Wendland PO Box 10412 Palo Alto, CA 94303	Oak Ridge National Laboratory Attn: J. Tomlinson Building 9204-1, MS 8045 Y-12 Plant, Box 2009 Oak Ridge, TN 37831-8045
	Energetics, Inc. Attn: Jon Hurwitch 9210 Route 108 Columbia, MD 21045	Office of Congressman Sid Morrison Attn: Kevin Billings, Legislative Asst. 1330 Longworth Bldg. Washington, DC 20515
	Institute of Gas Technology Attn: J. O'Sullivan 3424 S. State Chicago, IL 60612	Office of Congressman Tom Bevil 2302 Rayburn Bldg. Washington, DC 20515

No. of
Copies

Resource Efficiency, Inc.
Attn: M. Spurr
340 Daly Street
St. Paul, MN 55102

Rocket Research Company
Attn: D. D. Huxtable,
Director Energy R&D
York Center
Redmond, WA 98052

Rocket Research Company
Attn: L. B. Katter
York Center
Redmond, WA 98052

Sandia National Laboratories
Technical Library
Division 3141
Albuquerque, NM 87185

Solar Energy Research Institute
Attn: B. Gupta
1536 Cole Blvd.
Golden, CO 80401

University of Alabama
Attn: E. Brett
School of Mines and Energy
Development
Box 6282
University, AL 35486

University of Massachusetts
at Amherst
Attn: D. Breger
Dept. of Mechanical Eng.
Eng. Laboratory Bldg.
Amherst, MA 01003

University of Massachusetts
at Amherst
Attn: J. E. Sunderland
Dept. of Mechanical Eng.
Eng. Laboratory Bldg.
Amherst, MA 01003

No. of
Copies

US Army Corps of Engineers
Attn: C. W. Sohn
Construction Engineering
Research Laboratory
PO Box 4005
Champaign, IL 61820-1305

US Department of Interior
Attn: Natural Resources
Library
Serials Branch (G/E)
Washington, DC 20240

FOREIGN

Bengt Hidemark Gosta Danielson
Arkitekter SAR
Attn: A. Boysen
Jarntorget 78
S-11 29 Stockholm
Sweden

Commission of European
Communities
Attn: P. Zegers
DG XII, E3
200 Weststraat
Brussels, Belgium

DFVLR
Attn: M. Becker
Bereich Projekttragerschaften
Linder Hohe
5000 Koeln 90
West Germany

DIDIER Werke
Attn: C. Streuber
Lessingstrasse 16-18
D-6200 Wiesbaden 1
West Germany

Helsinki University of Technology
Attn: P. Lund
Otakaari 3
SF-02150 Espoo
Finland

No. of
Copies

Helsinki University of Technology
Attn: P. Vainio
Otakaari 3
SF-02150 Espoo
Finland

I.E.N.E.R.
EPF-Ecublens
Attn: B. Saugy
1015 Lausanne
Switzerland

IF Technology
Attn: A. Snijders
Fronbregstraat 1
6814 RE Arnhem
The Netherlands

Institut Fisica Universite
Attn: F. Reale
P. le Tecchio
80125 Napoli
Italy

Institut fur Kernenergetik
und Energiesystems
Attn: M. Groll
Universitat Stuttgart
Pfaffenwaldring 31
Postfach 801140
7000 Stuttgart 80
West Germany

Institut fur Kernenergetik
und Energiesystems
Attn: D. Steiner
Universitat Stuttgart
Pfaffenwaldring 31
Postfach 801140
7000 Stuttgart 80
West Germany

Institut fur Technische Physik
Attn: R. Tamme
Deutsche Luft- & Raumfahrt, e.V.
Pfaffenwaldring 38
7000 Stuttgart 80
West Germany

No. of
Copies

Institut fur Thermodynamik and
Waermetechnik
Attn: U. Gross
Universitat Stuttgart
Pfaffenwaldring 6
7000 Stuttgart 80
West Germany

KFA Julich
Projektleitung Energieforschung
Attn: F. J. Friedrich
PO Box 1913
D-5170 Julich
West Germany

KFA Julich, PLE
Attn: V. Lottner
PO Box 1913
D-5170 Julich
West Germany

KM Kjessler & Mannerstrale AB
Attn: S. Lundin
PO Box 7124
S-171 07 Solna
Sweden

Laboratory for Energetics
Attn: B. Qvale
Technical University of Denmark
DTH Building 403
DK-2800 Lyngby
Denmark

Lambrecht Industrial Consultants
Attn: J. Lambrecht
Max-Ruttgers-Str 29
D-8021 Irschenhausen
West Germany

B. Matthey
Consulting-Engineers Ltd.
CH-2205 Montezillon-Neuchatel
Switzerland

No. of
Copies

NOVEM
Attn: G. J. van Mourik
PO Box 8242
Leidseveer 35
3503 RE Utrecht
The Netherlands

Public Works Canada
Attn: E. L. Morofsky
C456 Sir Charles Tupper Bldg.
Riverside Dr. and Heron Rd.
Ottawa, Ontario
K1A 0M2 Canada

Riso National Laboratory
Attn: P. L. Christensen
DK-4000 Roskilde
Denmark

Swedish Council for Building
Research
Attn: W. Raldow
St. Goransgatan 66
S-11233 Stockholm
Sweden

Swedish Council for Building
Research
Attn: B. T. Sellberg
Sankt Goransgatan 66
S-11233 Stockholm
Sweden

Swiss Federal Energy Office
Attn: A. Fehr
CH-3003 Berne
Switzerland

Alan D. Solomon
90 Eschel Street
POB 227
Omer 84965
Israel

No. of
Copies

Universitat Stuttgart
Attn: Rudolf Giebe
Pfaffenwaldring 6
7000 Stuttgart 80
West Germany

ONSITE

DOE Richland Operations Office

D. R. Segna, A5-90

33 Pacific Northwest Laboratory

Z. I. Antoniak, K5-21
D. R. Brown, K6-61
M. K. Drost, K5-21 (5)
B. M. Johnson, K5-12
L. D. Kannberg K5-21 (15)
G. J. Posakony, K2-28
K. Sathyanarayana, H0-34
G. M. Stokes, K2-51
T. A. Williams, K6-61
Publishing Coordination
Technical Report Files (5)