

**THERMAL GASIFICATION OF DENSIFIED SEWAGE**  
**SLUDGE AND SOLID WASTE**

By

**Samuel A. Vigil and George Tchobanoglous**  
Department of Civil Engineering  
University of California, Davis

Prepared for presentation at the  
53rd Annual Water Pollution Control Federation Conference  
Thursday, October 2, 1980  
Las Vegas, Nevada

# THERMAL GASIFICATION OF DENSIFIED SEWAGE SLUDGE AND SOLID WASTE

Samuel A. Vigil and George Tchobanoglous

Department of Civil Engineering  
University of California, Davis

The disposal of sewage sludge in an economic and environmentally acceptable manner is a problem common to all communities that have municipal wastewater treatment facilities. Similarly, all communities are faced with the disposal of increasing quantities of solid waste. The co-disposal of sludge and solid waste in a common facility is a potential solution to both of these problems. The results of an experimental program to verify the feasibility of the gasification process for the co-disposal of densified sludge and source separated solid waste are presented in this paper.

## BACKGROUND

Facilities for the processing and disposal of wastewater sludges may account for up to 50 percent of the capital cost of a treatment plant. Up to 55 percent of the annual operating cost may be spent for sludge management. At present, many sludge processing alternatives are available. What must be done in the treatment of sludge is to combine one or more of these processes to meet the following goals: 1) sludge volume reduction, 2) stabilization, 3) pathogen reduction, and 4) energy efficiency.

### Conventional Approaches to Sludge Disposal

The unit operations and processes now used for sludge management can be assembled in an almost infinite variety of flowsheets. In general, two basic categories of flowsheets can be formulated: biological systems in which aerobic or anaerobic digestion is used to stabilize sludge, and thermal systems in which incineration or pyrolysis, thermal gasification, or liquefaction (PTGL) processes are used to reduce the volume and sterilize the sludge.

Biological processes have been used successfully to treat sludge for many years. The advantages of these processes are relatively simple operation, proven performance, and in the case of anaerobic digestion, the potential for energy recovery. The end product of a biological stabilization process is a wet slurry which usually must be dewatered for economic disposal. The end product of thermal processes is a dry, sterile ash or char which is a small fraction of the total influent solids. The principal disadvantage to these systems is their relatively high capital cost, and the need for external fuel (oil or natural gas). The principal differences between biological and thermal sludge processing systems are summarized in Table I.

**TABLE I. Characteristics of biological and thermal processing systems.**

Parameter	Type of System	
	Biological	Thermal
Residence time	Long (3-60 days)	Short (10sec-1 hour)
Start up time	Long (9-180 days)	Short (20min-1 hour)
Operational temperature	Low (20-35°C)	High (300-1100°C)
Operational complexity	Moderate	Low to high
Potential for automation	Moderate	Very high
Preferred feedstock	Nutritionally balanced, wet slurry	Dry
Residue	Biologically active, wet slurry	Dry, sterile ash or char

### Co-disposal of Sludge and Solid Waste

The main disadvantage to the thermal processing of sewage sludge is the need for auxiliary fossil fuel. Co-disposal of sludge and solid waste in a common system would eliminate or reduce the need for fossil fuels for the incineration of sludge, while reducing the landfill requirements for solid waste. Currently, there are no full scale co-disposal systems operating in the United States, however, several facilities are under construction or in the design stage. Co-disposal processes are of two basic types: in the first, a mass fired solid waste incinerator is used to combust dried sludge which has been mixed with unseparated municipal solid waste; in the second, a sewage sludge incinerator is modified to accept refuse derived fuel (RDF) as a substitute for the natural gas or oil normally used in such furnaces.

In addition, there are many pyrolysis, thermal gasification, and liquifaction (PTGL) processes being proposed for the conversion of biomass, sludge, and municipal, industrial, and agricultural waste into solid, gaseous, and liquid fuels. An excellent overview of many of the processes currently under development is given in Reference 1.

### Gasification as a Co-disposal Option

An alternate system for sludge disposal that could be used by both large and small communities involves the co-gasification of sludge and source separated solid waste. Such a system is shown schematically in Figure 1. The system consists of the following components: a shredder to reduce the size of waste paper and mix it with dewatered

sludge, a densification system to convert the sludge/waste paper mixture into a dense fuel cube, the gasification reactor, a gas cleanup system, and an engine-generator to convert the gas to electrical energy.

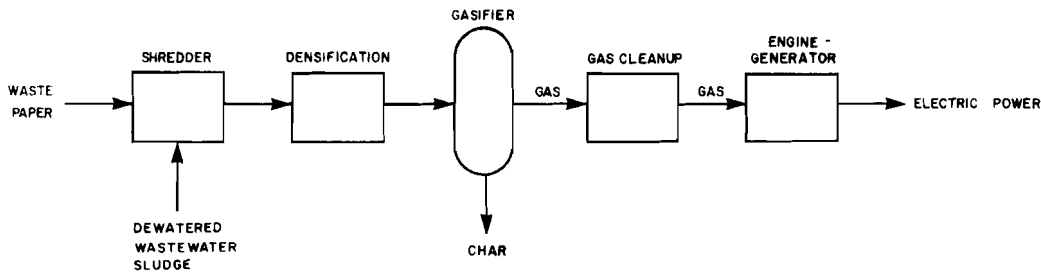

**FIGURE 1. Co-gasification system for sludge and solid waste.**

## GASIFICATION: AN OVERVIEW

Gasification is an energy efficient technique for reducing the volume of solid waste and the recovery of energy. Essentially, the process involves the partial combustion of a carbonaceous fuel to generate a combustible fuel gas rich in carbon monoxide and hydrogen. The historical development, the basic theory of operation, and the types of reactors used in the gasification process are discussed briefly below.

### Definition

Currently, there is much confusion in the literature between the terms pyrolysis and gasification. In this paper, the following definitions given by Lewis<sup>2</sup> are used.

"Pyrolysis - Thermal processing of waste in the absence of oxygen, in (a) indirectly heated retorts, and (b) furnaces that are directly heated by fuel gases from a burner firing on a stoichiometric air/fuel ratio."

"Gasification - Thermal processing of waste where a fraction of the stoichiometric oxygen required by the waste is admitted directly into the fuel bed to liberate the heat required for the endothermic gasification reactions. The volatile portion of incoming waste will be pyrolyzed by the heat of the fuel gases, and the outlet gas composition will reflect both processes."

### Historical Development

The inventor of the process is unknown, but stationary gasifiers were used in England in the early 1800's<sup>3</sup>. By the early 1900's, gasifier technology had advanced to the point where virtually any type of cellulosic residue such as rice hulls, olive pits, straw, and walnut shells could be gasified. These early gasifiers were used primarily to provide the

fuel for stationary gasoline engines. Portable gasifiers emerged in the early 1900's. They were used for ships, automobiles, trucks, and tractors. During World War II, France had over 60,000 charcoal burning cars while Sweden has about 75,000 wood burning gasifier equipped cars. With the return of relatively cheap and plentiful gasoline and diesel oil, after the end of World War II, gasifier technology was all but forgotten. However, in Sweden, research has continued into the use of wood fueled gasifiers for agriculture.

In the United States, gasification technology was, until recently, virtually ignored. In the early 1970's work was started in the United States on pyrolysis systems for energy recovery from solid wastes. Many of these pyrolysis systems for energy recovery from solid wastes are actually complex adaptations of the simple gasification process. For example, the PUROX process and the Envirotec multiple hearth pyrolysis system are in reality gasification systems.

### Reactor Types

Four basic types of reactors are used in gasification. They are: 1) vertical packed bed, 2) multiple hearth, 3) rotary kiln, and 4) fluidized bed. Most of the early gasification work in Europe was with the packed bed reactors. The other types are favored in current United States practice, with the exception of the PUROX oxygen blown gasifier (an updraft reactor). The vertical packed bed (VPBR) reactor has a number of advantages over the other types including simplicity and relatively low capital cost. However, it is more sensitive to the mechanical characteristics of the fuel. The merits and limitations of vertical packed bed gasifiers are discussed in detail in Reference.

In the VPBR gasifier fuel flow is by gravity with air and fuel moving co-currently through the reactor (see Figure 2). At steady state, four zones form in the reactor. In the hearth zone, where air is injected radially into the reactor, exothermic combustion and partial combustion reactions predominate. Heat transfers from this zone upward into the fuel mass, causing pyrolysis reactions in the distillation zone and partial drying of the fuel in the drying zone. Actual production of the fuel gas occurs in the reduction zone, where endothermic reactions predominate, forming CO and H<sub>2</sub>. The end products of the process are a carbon rich char and the low energy gas.

### Gasification Theory

A gasifier is basically an incinerator operating under reducing conditions. During the gasification process, six principal reactions occur:

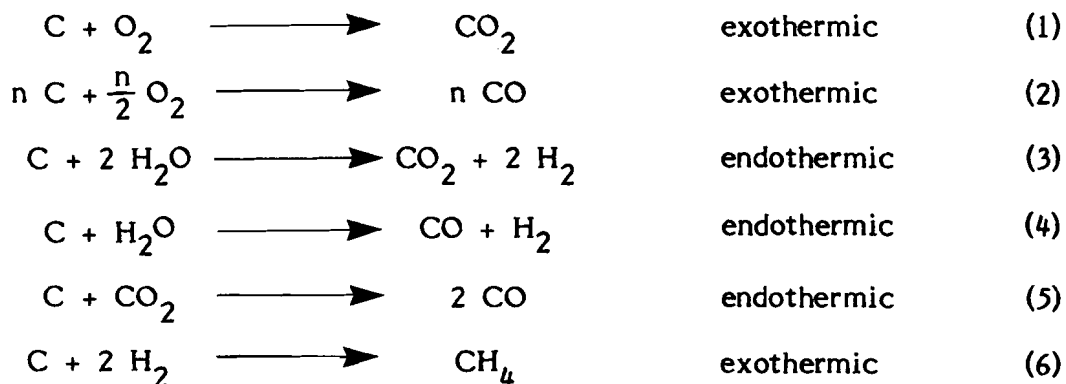

The heat to sustain the process is derived from the exothermic reactions while the combustible components of the low energy gas are primarily generated by the endothermic reactions. Although the reaction kinetics of the gasification process are quite complex and still the subject of considerable debate, the operation of air blown, downdraft gasifiers of the type used in this research is straightforward. An in-depth discussion of gasification theory and reaction kinetics may be found in References <sup>8, 9, 10</sup>.

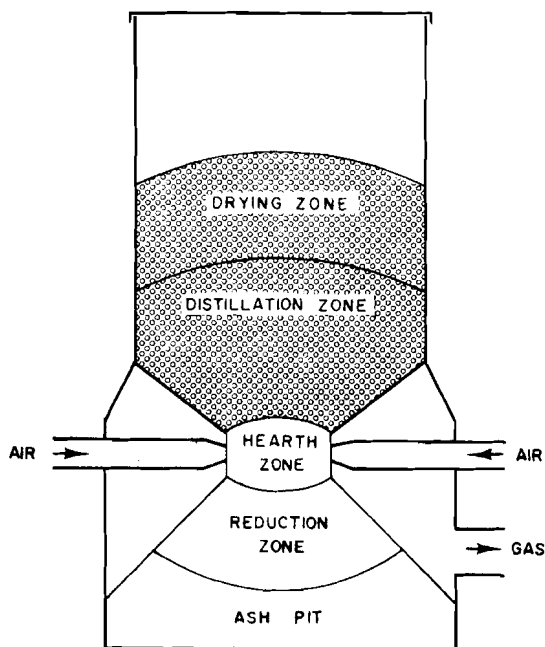

**FIGURE 2. Schematic of vertical packed bed reactor.**

**Gasification of Sludge/Solid Waste Mixtures**

Downdraft gasifiers are simple to construct and operate but they have exacting fuel requirements which include: 1) moisture content < 30 percent, 2) ash content < 10 percent, and 3) uniform fuel size. Since waste can be dried prior to gasification, excessive moisture can be overcome. However, ash content and fuel size are more difficult to handle. When the ash content is higher than 10 percent, solidified particles known as slag may form and cause operational problems. Excessive fine material in the fuel can cause mechanical bridging in the fuel hopper. A suitable fuel can be made by mixing dewatered sludge with the paper fraction of source separated solid waste, and densifying the mixture to produce a densified refuse derived fuel (d-RDF) that has low moisture content, low ash content, and uniform fuel size.

## Gas Composition

When a gasifier is operated at atmospheric pressure with air as the oxidant, the end products of the gasification process are a low energy gas (LEG) typically containing (by volume) 10% CO<sub>2</sub>, 20% CO, 15% H<sub>2</sub>, 2% CH<sub>4</sub>, with the balance being N<sub>2</sub>, and a carbon rich char. Due to the diluting effect of the nitrogen in the input air, the LEG has a energy content in the range of the 5.2 to 6.0 MJ/m<sup>3</sup>. When pure oxygen is used as the oxidant, a medium energy (MEG), with an energy content in the range of 12.9 to 13.8 MJ/m<sup>3</sup>, is produced. Because of their complexity and high capital cost, oxygen blown gasifiers have not yet been applied commercially. The simpler air blown gasifier has been used widely and is the subject of this paper. The low energy gas from a downdraft gasifier can be utilized in several ways. The simplest technique is to burn the gas with stoichiometric amounts of air in a standard boiler designed for natural gas. This requires minor modifications to the burner head to allow for more combustion air and enlargement of the gas feed pipes to account for the lower energy content of the gas ( $\approx 5.6$  MJ/m<sup>3</sup>) as compared to natural gas ( $\approx 37.3$  MJ/m<sup>3</sup>). Another approach is to cool and filter the gas and utilize it as an alternative fuel for internal combustion engines. Skov and Papworth described the operation of gasoline engine powered trucks, buses, and agricultural equipment in Europe with gas produced using portable wood fueled gasifiers. Gasifiers can also be used to operate diesel engines.

## EXPERIMENTAL APPARATUS, METHODS, AND PROCEDURES

To demonstrate the viability of the gasification process for the proposed application, a pilot scale gasifier has been operated with densified mixtures of sludge and solid waste. The experimental gasifier system, the preparation of the densified fuel, and the methods and procedures used in the collection and analysis of the data are considered briefly in this section.

### Experimental Gasification System

To demonstrate the feasibility of operating a downdraft gasifier with mixtures of sludge and solid waste, an experimental gasifier was designed and constructed. The complete system consists of three sub-systems: 1) batch fed downdraft gasifier, 2) data acquisition, and 3) solid waste shredding and densification.

**Batch Fed Gasifier** - A pilot scale batch fed downdraft gasifier was designed and constructed for the experiments reported on in this paper. The design of the gasifier was based on earlier work done by the Swedish government in the late 50's and also on more recent work by the Department of Agricultural Engineering at the University of California, Davis. As shown in Figures 3, 4, and 5, the gasifier is built in three main assemblies, fuel hopper, firebox, and ashpit. The fuel hopper is a double walled cylinder. The inner wall is in the form of a reverse taper cone to reduce the tendency for fuel bridging. The function of the double wall is to act as a condenser to remove water vapor from the fuel prior to gasification. The condensed vapor is collected in a condensate gutter and drained off after each run. The condensate gutter was patterned after those used in Swedish automotive gasifiers. Some researchers doubt the necessity for a gutter and at least one gasifier manufacturer has eliminated it from their designs. This might produce a gas with a higher moisture content but would eliminate condensate as a waste stream. The fuel hopper is mounted on the firebox with quick release bolts to allow for easy inspection after experimental runs.

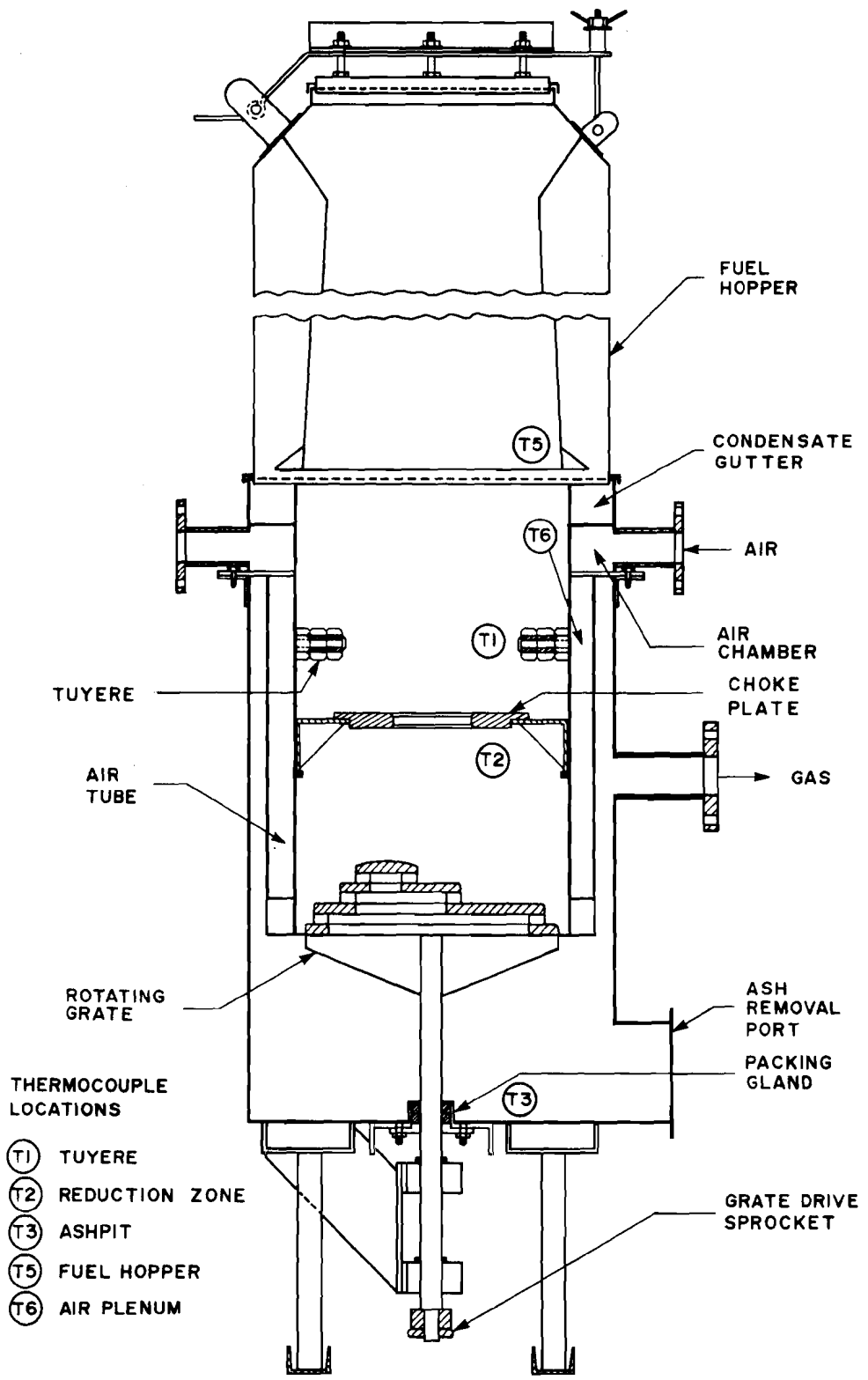
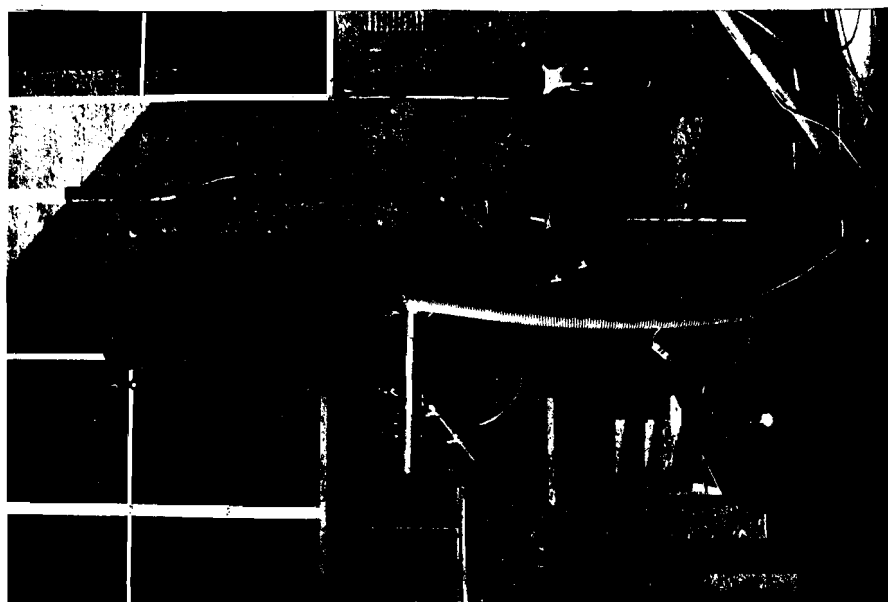

**FIGURE 3. Cross section - UCD sludge/solid waste gasifier.**





**FIGURE 5. Interior view -  
UCD sludge/solid waste gasifier.**



**FIGURE 4. Exterior view -  
UCD sludge/solid waste gasifier.**

The firebox is also a double walled cylinder. The inner cylinder is the chamber where the gasification reactions occur. The space between the double walls act as a manifold to distribute air evenly to the six tuyeres (air nozzles) which supply air for the gasification reactions. The choke plate is mounted inside the firebox on a removable ring. The choke plate acts as a large orifice plate, replacing a venturi section previously used in the earlier World War II and Swedish gasifier designs. The firebox assembly is flange mounted to the ashpit.

The ashpit is used to collect the char during an experimental run. A rotating eccentric grate is mounted in the bottom of the ashpit. The grate supports the fuel bed, and allows the passage of char and gas into the ashpit. The gas is continuously drawn off through a pipe on the side of the ashpit. The char is removed through a quick release port.

**Data Aquisition** - The data aquisition sub-system is an automated temperature measurement system. Temperatures are sensed with Type K thermocouples located as shown in Figure 3. Additionally a Type T thermocouple is used in the air inlet line, a Type K thermocouple is installed in the gas outlet pipe, and provision is made for three magnetically mounted Type K thermocouples for surface temperature measurements. The thermal emf from the thermocouples is converted to temperatures by a Digitec Model 1000 Datalogger. The channel number, temperature, and elapsed time are printed on the paper tape output of the instrument. Since it was desired to monitor two critical temperatures on a continuous basis, two additional thermocouple readout devices were installed. These units permit continuous monitoring of the fuel hopper and tuyere temperatures during operation. These temperatures are also recorded automatically by the Datalogger. A schematic of the thermocouple system and a photograph of the complete data analysis subsystem are shown in Figures 6 and 7.

**Solid Waste Shredding and Densification** - Densified fuels are required for the operation of packed bed gasifiers. The simplest type of densification system consists of a shredder followed by an agricultural type cubing machine. Originally built to produce densified animal feeds, these machines can be easily modified to produce solid waste fuel cubes. One of the first systems of this type was operated during the early 1970's in Fort Wayne, Indiana to produce a solid waste fuel for the city power plant<sup>14</sup>. A more recent application of solid waste densification was demonstrated by the Papakube Corporation of San Diego, which manufactures solid waste cubes as a boiler fuel<sup>15, 16</sup>.

Since the capacity of commercially available densification systems is relatively large (1.8 to 4.5 metric tons per hour capacity) compared to the gasifier (16 to 40 kg/hr capacity), a densification system was not built especially for this project. Rather, existing densification systems on the university campus and the pilot plant densification system operated by the Papakube Corporation, San Diego, California were utilized. Key features of the Papakube system include an integral shredder, a metering system which allows moistening the paper to the optimum moisture content, and a modified John Deere Cuber (see Figure 8).

### **Field Testing**

In addition to the gasifier temperatures that are recorded automatically by the data analysis subsystem, the following data are recorded manually during test runs.

**Air and Gas Flows** - Air and gas flows were measured using standard flange mounted orifice plates in the air inlet and the gas flare line. The orifice plates are calibrated



FIGURE 7. Data analysis sub-system for monitoring gasifier operation.

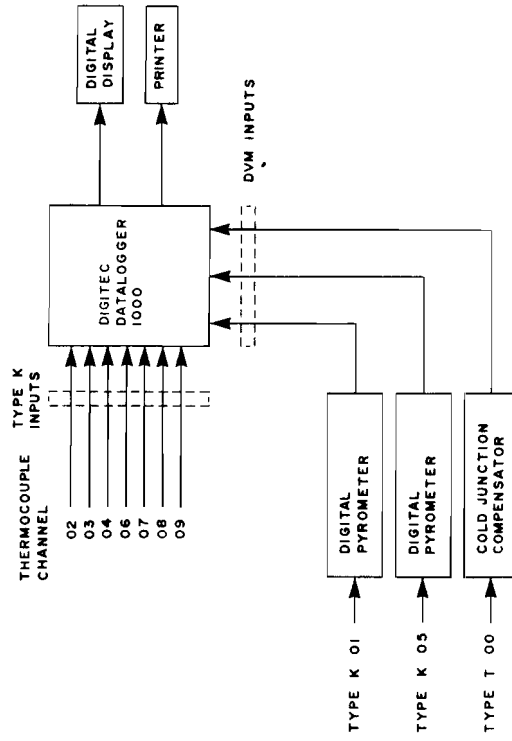

FIGURE 6. Schematic of thermocouple system used to monitor gasifier temperatures.

both before and after each run. Since the gas flare orifice was calibrated with air at ambient temperature, corrections for the temperature and average density of the low energy gas must be made.

**Weight Loss** - The entire gasifier is mounted on platform scales. The weight of the gasifier is recorded at 5 minute intervals. Since the char is accumulated in the ashpit, the weight loss during the run is a direct measure of gas generation.

**Pressure Drop** - The pressure drop across the fuel bed is measured periodically during the run. When the pressure drop exceeds 5 cm of water the grate is rotated, displacing char into the ashpit.

**Char** - Char samples were collected on the day following the run to allow the gasifier to cool. Samples for analysis were collected from the reduction zone when the gasifier is partially dissembled for inspection after each run.

**Condensate** - At the conclusion of each run condensate is drained from the gasifier, weighed, and a sample saved for later analysis.

**Slag** - To assess the potential of sludge/waste paper cubes to cause slagging, the gasifier is partially disassembled after each run, and the residual char in the firebox removed and sifted for slag agglomerations.

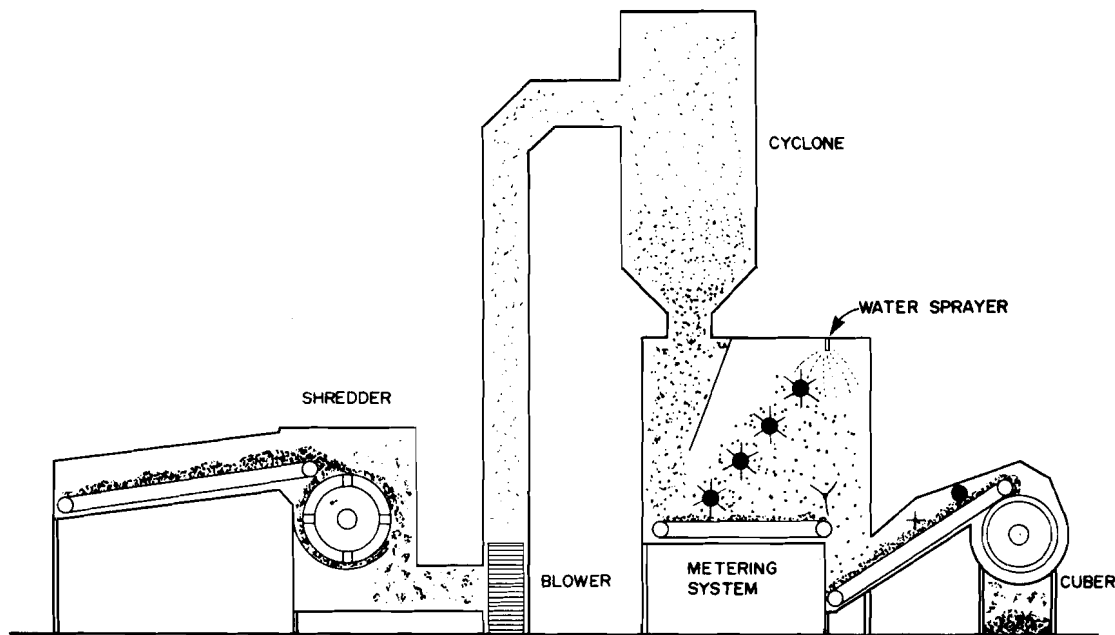

FIGURE 8. Schematic of the Papakube densification system.

## Laboratory Testing

Samples of gasifier fuels, chars, and condensate are tested. Grab samples of the low energy gas are also analyzed. The sampling techniques, apparatus, and methods used for fuel, char, and gas composition are described below and summarized in Table II.

**Fuel and Char Tests** - Proximate analyses of the fuel and char are determined according to ASTM Standard Methods. Ultimate analysis for percent C, H, N, S, and O of the fuel, char, and condensate are conducted by the Chemistry Department, University of California Berkeley campus. The energy content of the fuel and char is determined with a Parr Oxygen Bomb Calorimeter.

**Gas Sampling and Analysis** - Gas samples are collected in Tedlar gas sampling bags. The gas samples are analyzed on a Leeds and Northrup process gas analyzer system. Percent CO, CO<sub>2</sub>, O<sub>2</sub>, H<sub>2</sub>, and hydrocarbons are determined. Samples are extracted from the gas flare line with a sample train consisting of a condenser, glass fiber filter, molecular sieve column, and a diaphragm pump. The moisture content of the gas is determined with a MISCO Model 7200 Source Sampler by the condensation method as described in Reference<sup>6</sup>.

**TABLE II. Summary of data collection and analysis equipment.**

Test	Sampling Technique	Apparatus	Reference
Proximate analysis	Grab samples of fuel and char	Drying oven, muffle furnace, desiccator	ASTM D3172-73 "Standard Method for the Proximate Analysis of Coke and Coal"
Ultimate analysis	Grab samples of fuel and char	C, H, N w/ Perkin-Elmer Gas Analyzer S by Grote Combustion Method ppt w/ BaSO <sub>4</sub>	Micro-Analytical Laboratory Department of Chemistry University of California, Berkeley
Energy content	Grab samples of fuel and char	Parr Adiabatic Oxygen Bomb Calorimeter	ASTM D-2015-66 "Gross Calorific Value of a Solid Fuel by the Adiabatic Bomb Calorimeter"
Dry gas composition	Grab sample of gas	Leeds and Northrup Multi-Component Gas Analyzer (H <sub>2</sub> , CO, CO <sub>2</sub> ) Leeds & Northrup Thermo-magnetic O <sub>2</sub> Analyzer Beckman Total Hydrocarbon Analyzer Leeds & Northrup Modular Gas Sampling System	Manufacturers operational manuals. Calibration by standard gas mixtures.
Gas moisture	Grab sample of gas	Ice water impingers, MISCO Model 7200 Source Sampler	Cooper, H.B.H. Jr., and A.T. Rosano, Jr., <u>Source Testing for Air Pollution Control</u> McGraw Hill Book Co., NY (1974).
Cube physical properties	Grab sample of fuel	Laboratory balance	ASAE S269.2 "Wafers, Pellets, and Crumbles - Definitions and Methods for Determining Specific Weight, Durability and Moisture Content".

## Energy Balance Computations

In an energy balance the energy input to the gasifier is compared with the energy output. Energy inputs include: the sensible and latent heat of the air blast; and the sensible heat and heat of combustion of the fuel. Energy outputs include: the heat of combustion and sensible heat of the dry gas; the sensible and latent heat of the steam in the gas; the sensible heat and heat of combustion of the char; the sensible heat, heat of combustion, and latent heat of the condensate; and convection and radiation losses. Significant data required for mass and energy balances are summarized in Figures 9 and 10. Several simplifications that can be made to the energy balance are discussed below. Details including appropriate computer programs may be found in Reference<sup>17</sup>.

**Energy Inputs** - The sensible heat of the air blast is determined by measuring the temperature of the input air. The latent heat of the air blast is computed by measuring the relative humidity of the ambient air and solving for the absolute humidity at the temperature of the air blast. However, in energy<sup>8</sup> balances conducted on gasification tests of 30 types of agricultural residues, Jenkins<sup>8</sup> found that the sensible and latent heat of the air blast was less than 0.1 percent of the heat of combustion of the fuel. Therefore, the energy input of the air blast was ignored. The principal input of energy to the gasifier is the heat of combustion of the dry fuel. This must be reduced to account for the heat of vaporization of the combined water in the dry fuel and the free moisture of the fuel as fired.

**Energy Output, Gas** - The principal energy output of the gasifier is in the form of low energy gas. The energy in the gas is contained in three forms: chemical energy, sensible heat, and latent heat of the gas moisture. In these tests reported on in this paper, the latent heat was not considered because the gas moisture was not condensed. The chemical energy of the gas is computed by multiplying the volume fraction of each gas component, as determined by the dry gas analysis, by the saturated energy content of each component gas, and summing the total.

The sensible heat in the gas is computed by first calculating the mean specific heat at constant pressure for each gas component and then computing the sensible heat of the gas between the average gas temperature and the average gas temperature at the moisture sampler condenser.

**Energy Output, Char** - Energy also leaves the gasifier the form of the sensible and latent heat, and heat of combustion of the char. Since cool char is removed from the gasifier on the day following the run, the sensible heat is ignored. The heat of combustion of the char is determined by bomb calorimeter tests.

**Energy Output, Condensate** - The condensate is also an energy output. Since condensate is removed from the gasifier at ambient temperature, the latent and sensible<sup>18</sup> heat of the condensate are ignored. The heat of combustion determined by Jenkins<sup>18</sup>, 4.75 MJ/kg, was assumed.

**Losses** - Energy losses from the gasifier include convection and radiation from the gasifier structure. Losses are determined by balancing the net energy into the gasifier against the energy outputs. Losses may also reflect errors in determining the gas flow rate and the char generation rate.

**Efficiencies** - The efficiency of a gasifier can be defined in terms of the hot and cold gas efficiency. The hot gas efficiency is the appropriate figure to use when the sensible heat of the low energy gas can be utilized, such as in direct coupled boiler operation.

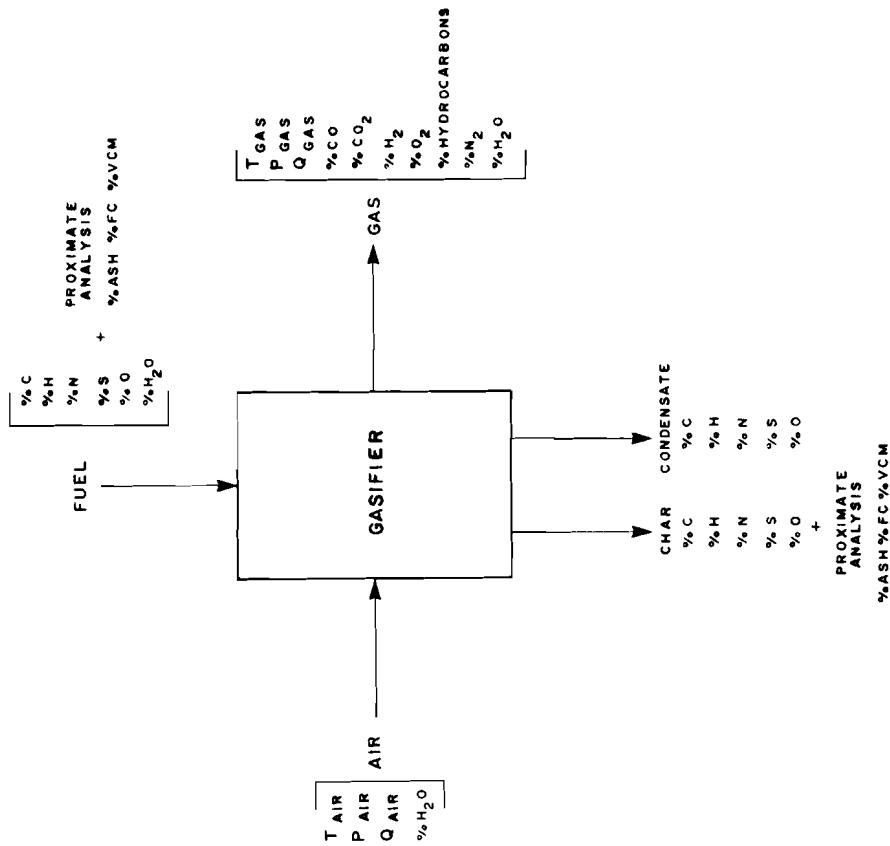
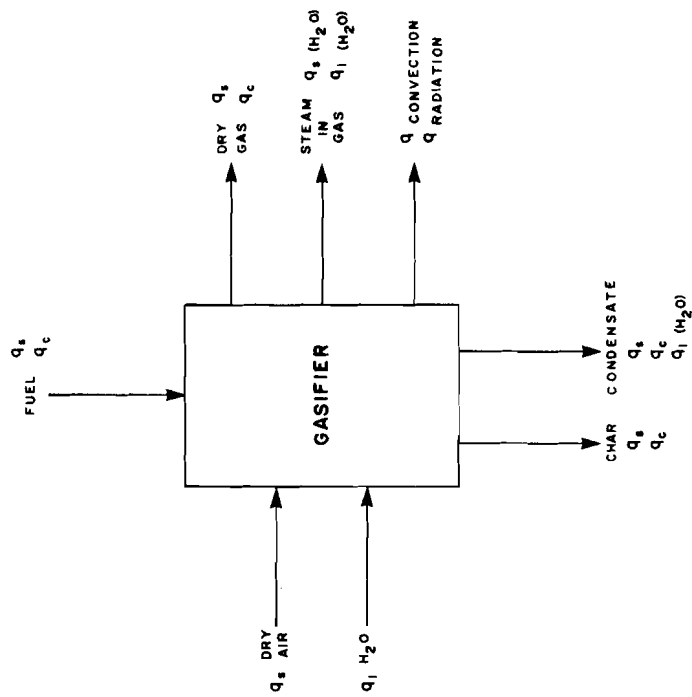

FIGURE 9. Data required for preparation of mass balance of gasifier operation.



$q_s$  = SENSIBLE HEAT  
 $q_c$  = HEAT OF COMBUSTION  
 $q_l$  = LATENT HEAT

FIGURE 10. Data required for preparation of energy balance of gasifier operation.

The cold gas efficiency represents the efficiency that could be expected when the low energy gas is used to power an internal combustion engine, which requires that the gas be cooled, thus wasting the sensible heat.

## EXPERIMENTAL RESULTS

The gasifier was operated with four different densified mixtures of sludge and solid waste. The characteristics of these fuels, operational data from the test runs, and energy balances for the runs are presented and discussed in this section. Results from gasification tests with other biomass fuels are given in References 17, 19, 20.

### Fuel Characteristics

Samples of lagoon dried, mixed primary and secondary sludge (approximately 60 percent solids) from the University's treatment plant were collected and trucked to the Papakube pilot plant in San Diego. Five batches of cubes (approximately 200 kg each) were prepared by placing preweighed dried sludge and newsprint on the conveyor belt of the densification system. The violent mixing action of the shredder, blower, and cyclone were sufficient to ensure uniform mixing of sludge particles and shredded paper (see Figure 8). Mixtures 10, 15, 20 and 25 percent sludge (by wet weight) were prepared.

**TABLE III. Summary of fuel characteristics used for gasification studies.**

Item	RUN 09	RUN 10	RUN 11	RUN 12
Fuel description	10% Sludge Cubes	15% Sludge Cubes	20% Sludge Cubes	25% Sludge Cubes
Proximate analyses				
VCM, %	83.87	75.10	74.54	73.66
FC, %	8.19	12.19	13.05	13.70
Ash, %	1.11	2.62	3.07	4.08
Moisture, %	6.83	10.09	9.34	8.56
Ultimate analyses (Dry basis)				
C, %	46.46	45.99	45.24	45.27
H, %	5.98	5.89	5.81	5.77
N, %	0.19	0.19	0.13	0.42
S, %	0.14	0.10	0.11	0.16
O, %	45.33	44.83	46.81	44.18
Residue	1.90	3.00	1.90	4.20
Energy content, MJ/kg (Dry basis, HHV)	19.04	18.88	18.93	18.49



All fuel cubes were tested for proximate analysis, ultimate analysis, and energy content. The results of these analyses are summarized in Table III. In general, the fuel cubes were all relatively high in volatile combustible matter (VCM), low in carbon content, and low in energy content (HHV) as compared to coal which has a VCM of 30 to 40 percent, a carbon content greater than 70 percent, and a HHV of about 30 MJ/kg. Both bulk and unit densities of the fuels were also measured (see Table IV). The bulk density is a significant parameter in regards to storage and transportation requirements. Densified fuels are over twice the bulk density of natural biomass fuels such as wood chips and almond shells. If truck transportation is the only criterion densified fuels exceed the optimum economic density for truck transport ( $\approx 256 \text{ kg/m}^3$ ), when a truck reaches both its volume and weight limits for over the highway transportation.

### Operational Data

An operational summary of the test series is given in Table V. All test runs were conducted at the same air flow rate,  $0.36/\text{m}^3/\text{min}$  (1 atmosphere,  $0^\circ\text{C}$ ). Thus, the flow rate of fuel through the gasifier, the efficiency, and gas quality are a function of the gasification characteristics of the fuel. The results of the gasification test series including the fuel, char, and condensate rates; air and gas flows; weight and volume reductions; and temperature profiles are discussed below.

**Fuel, Char, and Condensate Rates** - The fuel consumption rate is the primary parameter used to compare the gasification potential of fuels. It is calculated as shown:

$$\text{Fuel consumption rate} = \frac{\text{Weight loss during run} + \text{Condensate removed} + \text{Char removed} + \text{Slag removed}}{\text{Net run time}}$$

Where: Net run time = Run time - (Refueling time + Other down time)

**TABLE IV. Densities of gasifier fuels.**

Fuel	Run No.	Densification process	Bulk density, $\text{kg/m}^3$	Unit density, $\text{kg/m}^3$
10% Sludge cubes	09	Papakube	374	738
15% Sludge cubes	10	Papakube	445	932
20% Sludge cubes	11	Papakube	536	1010
25% Sludge cubes	12	Papakube	486	1014

It was originally assumed that the fuel consumption rate was inversely related to the bulk density. However, from a review of the data in Tables IV and V it can be seen that the densified fuel with the lowest consumption rate, 15 percent sludge, was among the least dense of the densified fuels. In both wood and coal gasification studies, it has been found that the surface roughness and porosity of fuels has a profound effect on the rate of gasification<sup>3, 9</sup>. Surface properties of the solid waste/sludge cubes were not investigated during this project but are currently under study. Char and condensate production rates were determined by weighing the char and condensate removed after each run. The differences between the rates for each fuel were not significant.

**Air and Gas Flows** - In addition to the gas flow measurements made with the flare stack orifice plate, gas flows were computed by mass and nitrogen balances. The gas flow was computed with the mass balance by comparing the air and fuel flow into the gasifier with the gas, char, and condensate output rates. The gas flow was computed with the nitrogen balance by comparing the nitrogen in the input airflow with the nitrogen in the low energy gas (nitrogen in the fuel, char, and condensate was assumed to be negligible).

The correlation between the gas flows determined by the orifice plate measurements and the nitrogen balances was not good. This was probably due to a heavy particulate build up which was noted on the flare stack orifice plate after each run. Therefore, gas flows were computed based on the average of the mass and nitrogen balances.

**TABLE V. Operational summary.**

Item	RUN 09	RUN 10	RUN 11	RUN 12
Fuel description	10% Sludge cubes	15% Sludge cubes	20% Sludge cubes	25% Sludge cubes
Fuel consumption rate, kg/hr	21.4	12.3	17.5	16.3
Char production rate, kg/hr	1.15	1.40	2.47	1.71
Condensate production rate, kg/hr	0.58	0.82	0.50	0.73
Net run time, min	251	407	265	262
Gas flare ignition time, min	9	31	24	44
Air input rate, m <sup>3</sup> /min (0°C, 1 atm)	0.36	0.36	0.36	0.36
Gas output rate, m <sup>3</sup> /min (0°C, 1 atm)	N/A <sup>a</sup>	N/A	0.68	0.66
Average reduction zone temperature, °C	828.8	656.4	779.8	734.7
Average gas outlet temperature, °C	193.5	149.1	197.6	180.6
Volume reduction, %	81	73	64	74
Weight reduction, %	91	80	82	83

<sup>a</sup>Not available

**Weight and Volume Reduction** - Weight reduction for sludge/solid waste cubes ranged from 91 to 83 percent for 10 to 25 percent sludge mixtures respectively. Similarly, the volume reduction ranged from 64 to 81 percent for 10 to 20 percent sludge mixtures respectively (see Table V). Greater volume and weight reductions may be possible by optimization of the gasification process.

**Temperature Profiles** - The most important temperatures from an operational viewpoint are the reduction zone and gas outlet temperatures. Average reduction zone and gas temperatures for each run are given in Table V. Temperature profiles for RUN 10, 15 percent sludge/solid waste cubes, are shown in Figures 11 and 12. Due to gas sampling problems, the run was done in two parts, with 3 hours of down time in between. The first part was 310 minutes long with 28 minutes of down time, for a net run time of 282 minutes. The second part of the run was 140 minutes long with 15 minutes of down time, for a net run of 125 minutes. The average reduction zone temperature for the first part was 636°C, and 698°C for the second part, with an overall average temperature of 656°C. The average gas temperature for the first part was 148°C, for the second part, 151°C, with an overall average of 149°C.

The reduction zone temperature was 843°C when the first part of the run was terminated. When the gasifier was restarted after 3 hours of down time, the reduction zone had cooled to 230°C. This allowed an extremely fast start-up of the gasifier compared to the initial start-up. Thus, packed bed gasifiers exhibit a heat reservoir effect similar to fluidized bed incinerators.

**Gas Analyses** - Gas samples were collected for analysis during RUNS 9 through 12. However, due to problems with the gas sampling train, analyses are only available for RUNS 11, and 12. Dry gas composition, gas moisture content, and gas energy content are summarized in Table VI. The dry gas compositions measured during RUNS 11, and 12 were within the normal range expected for air blown gasifiers. The energy content of the gas samples was within the typical range expected for low energy gas.

### **Char, Condensate, and Slag Characteristics**

Samples of char and condensate were collected after each run. The char remaining in the gasifier firebox after each run was sifted for slag agglomerations.

**Char** - Significant characteristics of the chars are summarized in Table VII. The proximate analyses indicate that the chars are low in volatile combustible matter (VCM) and high in fixed carbon (FC) in comparison to the sludge/solid waste mixtures (see Table III). In this respect the chars are similar to coals which are also low in VCM. The ash content of the chars is very high, ranging from 43 to 80 percent. This would limit their use as a fuel.

A review of the ultimate analyses of the chars shows that relative to the gasifier fuels, the chars are high in carbon content and low in oxygen. The low oxygen content is confirmed by the high energy content of chars from RUNS 09 through 12. However, when the chars were ignited in the oxygen bomb calorimeter, small metallic looking balls of slag were formed, indicative of the high ash content of the chars.

Although the chars have relatively high energy contents, their high ash content would seem to preclude their use as a gasifier fuel. Although the char could be blended into the fuel of subsequent runs, a more promising use of the chars may be to utilize them

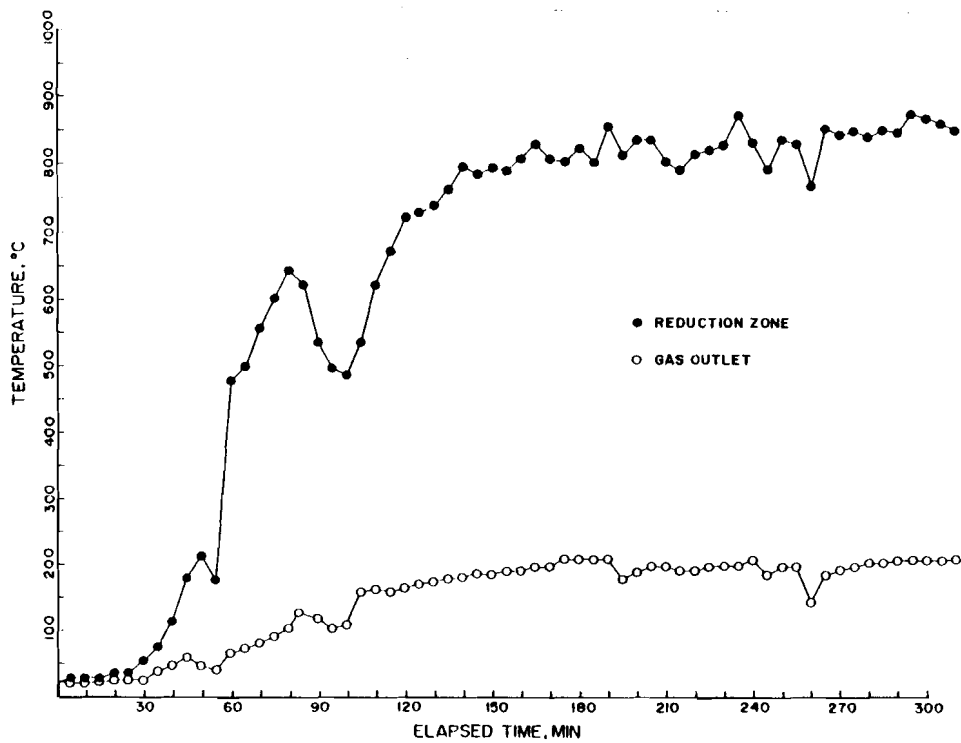

**FIGURE 11. Temperature profiles for gasifier reduction zone and low energy gas (RUN 10).**

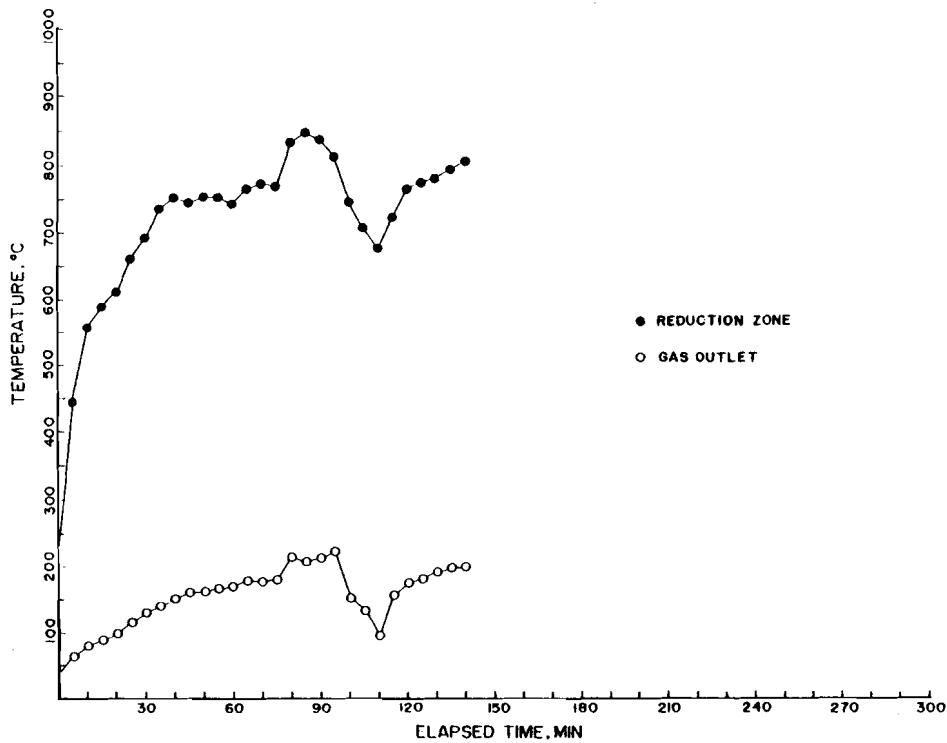

**FIGURE 12. Temperature profiles for gasifier reduction zone and low energy gas (RUN 10 continuation).**

in the polishing of wastewater treatment plant effluent as a substitute for activated carbon. This possibility is currently under investigation. Char samples from RUNS 09, 10, 11, and 12, as well as chars from agricultural residues, are being evaluated.

**TABLE VI. Composition and energy content of low energy gas.**

Item	RUN 11	RUN 12
Dry gas composition (By volume)		
CO, %	20.9	21.5
H <sub>2</sub> , %	14.5	13.7
CH <sub>4</sub> , % <sup>a</sup>	2.3	2.5
C <sub>2</sub> H <sub>6</sub> , % <sup>a</sup>	0.1	0.1
CO <sub>2</sub> , %	11.9	11.0
O <sub>2</sub> , %	0.3	0.3
N <sub>2</sub> , %	50.0	50.9
Gas moisture content (By volume), %		
	17.2	16.1
Gas energy content MJ/m <sup>3</sup> (Saturated, 0°C, 1 atm.)		
	5.02	5.08

<sup>a</sup>Measured as total hydrocarbons, CH<sub>4</sub> assumed to be 95% of THC, C<sub>2</sub>H<sub>6</sub> assumed to be 5% of THC

**Condensate** - Detailed chemical analyses of the condensate were not conducted, but ultimate analyses for the condensate are given in Table VIII. In gasification experiments with agricultural wastes, Jenkins<sup>18</sup> found that condensate is about 80 percent water. He also observed that condensate was produced mainly during start-up and shut-down. The average energy content of the condensate was found to be 4.75 MJ/kg.

**Slag** - The weight of the ash in the fuel and char, and the amount of slag recovered after each run, are summarized in Table IX. In all cases the ash recovered in the char exceeded the total ash theoretically contained in the fuel consumed during the run. This discrepancy was probably caused by sampling errors since the amount of char generated during a run is not precisely known. The slag generated in each run was approximately half the weight of the ash originally in the fuel. Individual agglomerations were sometimes quite large, exceeding ten centimeters in length. Although no operational problems were experienced with the sludge/solid waste fuels tested, run times were relatively short. Longer test runs will be needed to evaluate fully the slagging potential of sludge/solid waste mixtures.

**TABLE VII. Summary of gasifier char characteristics.**

Item	RUN 09	RUN 10	RUN 11	RUN 12
Fuel description	10% Sludge cubes	15% Sludge cubes	20% Sludge cubes	25% Sludge cubes
Proximate analyses				
VCM, %	6.50	3.39	2.60	5.60
FC, %	49.40	46.16	16.90	18.50
Ash, %	42.90	49.56	79.80	75.30
Moisture, %	1.20	0.88	0.70	0.60
Ultimate analyses (Dry basis)				
C, %	35.78	70.38	79.01	68.55
H, %	1.00	1.49	0.75	1.36
N, %	0.21	0.33	0.27	0.62
S, %	0.05	0.18	0.20	0.19
O, %	0.00	6.12	2.37	2.68
Residue	64.70	21.50	17.40	26.60
Energy content, MJ/kg (Dry basis, HHV)	22.15	24.37	27.60	24.38

<sup>a</sup>As oxides, therefore total is greater than 100%

**TABLE VIII. Summary of condensate characteristics.**

RUN	Ultimate Analyses, %				
	C	H	N	S	O
09	7.56	10.25	0.25	0.08	81.86
10	7.12	10.31	0.07	0.10	82.40
11	6.06	10.24	0.09	0.07	83.54
12	7.55	10.37	0.12	0.05	81.91

**TABLE IX. Char and slag generation.**

Item	RUN			
	09	10	11	12
<u>Fuel</u>				
Sludge content, %	10	15	20	25
Ash, %	1.1	2.6	3.1	4.1
Total fuel, kg	89.4	83.2	77.2	75.1
Total ash, kg	1.0	2.2	2.4	3.1
<u>Char</u>				
Ash, %	42.9	49.6	79.8	75.3
Total char, kg	4.8	9.5	10.9	7.5
Total ash, kg	2.1	4.7	8.7	5.6
<u>Slag</u>				
Total slag/kg	0.6	1.2	0.8	1.0
<u>Totals</u>				
Char ash + slag, kg	2.7	5.9	9.5	6.6
Char ash + slag/fuel ash, %	270	270	400	213

Several techniques exist to control slagging. The easiest solution is to limit the ash content of the sludge/solid waste cubes by controlling the ratio of sludge to solid waste. Another technique is to operate the gasifier with a steam/air blast instead of air. This will reduce temperatures in the combustion zone below the point where ash is melted. This method of temperature control is common in coal gasification. A third technique is to operate the gasifier at high temperature conditions, deliberately producing a molten slag which can be tapped and drained off during the run. This approach is used in the PUROX Process, in which a pure oxygen blast is used instead of air.

### Energy Balances - Runs 11 and 12

Energy balances for RUNS 11 and 12, computed using the approach discussed previously, are shown in Table X. Referring to Table X, energy balances are given both in energy units, MJ/hr, and percentages, assuming the fuel net energy as 100 percent. The gas chemical energy is the most significant energy output, ranging from 63 to 69 percent of the input net energy. The gas sensible heat is relatively minor, contributing about 4 percent to the energy output. The gas sensible heat could probably be increased by insulation of the ashpit and gas piping to the flare. A far more significant energy output is the char energy, which ranged from 17 to 25 percent of the input net energy. As char generation is sensitive to fuel residence time and air flow rate, char energy could be minimized by proper operation. Condensate energy is very minor varying from 0.9

**TABLE X. Energy balances.**

Item	RUN 11		RUN 12	
	MJ/hr	%	MJ/hr	%
Gross energy, dry fuel	296.49		268.08	
Latent heat, combined water	20.39		18.31	
Latent heat, fuel moisture	4.44		4.36	
Net energy, fuel	271.66	100.00	245.42	100.00
Gas chemical energy	169.59	62.43	168.78	68.77
Gas sensible heat	11.06	4.07	9.72	3.96
Char energy	69.00	25.40	41.45	16.89
Condensate energy	2.38	0.87	3.33	1.35
Energy losses	19.63	7.23	22.15	9.02
Hot gas efficiency		66.50		72.73
Cold gas efficiency		62.43		68.77
Fuel description	20% Sludge cubes		25% Sludge cubes	

to 1.4 percent of the input net energy. Energy losses ranged from 9 to 20 percent. Hot and cold gas efficiencies were 67 and 62 percent, respectively for RUN 11 and 73 and 69 percent for RUN 12.

**Comparison of Experimental Efficiencies with Efficiency Values Reported in the Literature** - The gasifier efficiencies found in this work are similar to the laboratory scale test results reported by other researchers. Williams and Goss<sup>22</sup>, in tests with the UCD agricultural waste gasifier fueled with walnut shells, reported cold gas efficiencies of 63 to 81 percent, dependent on the fuel consumption rate. Jantunen and Asplund<sup>12</sup>, using a Volvo automotive gasifier fueled with milled peat, reported cold gas efficiencies less than 60 percent. They commented that insulation of the gasifier firebox and air preheating could improve the efficiency. Cruz<sup>23</sup>, reported cold gas efficiencies in the range of 65 to 82 percent for an updraft gasifier fueled with coconut husks.

Somewhat higher efficiencies have been reported in full scale gasifiers. Mauerer and Lonick<sup>24</sup> claimed hot gas efficiencies of 88 to 92 percent for a full scale (900 kg/hr), anthracite coal fueled, Wellman-Galusha coal gasifier installed at a Pennsylvania brick kiln. Goss<sup>25</sup> reported hot gas efficiencies of 83 percent with a 300 kg/hr, continuous feed, pilot scale wood gasifier in a 531 hour extended test at the University of California, Davis Primate Center. These somewhat higher hot gas efficiencies reported for the Wellman-Galusha coal gasifier and the Davis pilot scale wood gasifier are probably more representative of what can be expected with a large scale, continuous flow, sludge/solid waste gasifier.

## **THE APPLICATION OF GASIFICATION TECHNOLOGY IN A MUNICIPAL SETTING**

The successful gasification of densified sludge/solid waste mixtures has been demonstrated in this project. Some applications of gasification technology in a municipal setting are reviewed in this section.



## The Role of Gasification in Large Municipalities

It has become more apparent in recent years that coupling together treatment of the liquid and solid waste streams of a community makes good sense from both an economic and technical viewpoint<sup>26</sup>. The relative simplicity of the gasification process lends itself to satellite operation in larger cities. For example, source separated solid waste (or sludge/solid waste mixtures) could be densified at a large central facility and trucked to satellite gasifiers in other parts of the city. Or in the case of large urban areas with several landfill sites and wastewater treatment plants, complete co-gasification systems could be located at each site.

## The Role of Gasification In Small Municipalities

The implementation of gasification in a small community setting will require several commitments on the part of the community:

1. An institutional framework for economic and management co-operation between solid waste and wastewater treatment authorities must be established.
2. A community wide source separation system for the production of a suitable gasifier fuel will be required.
3. The technical expertise to manage and operate a co-gasification system will need to be developed, preferably within the existing staff of the solid waste collection and wastewater treatment agencies.

Although a gasification system could be operated in a small community strictly with source separated solid waste and sludge, a more cost effective approach might be to incorporate the gasification system with the other waste generating activities of the city and its environs. If the gasifier system is located at the site of the city wastewater treatment plant, the low energy gas could then be used efficiently on-site to power pumps, blowers and other equipment.

Provisions could also be made for the inclusion of urban biomass. Operation of downdraft gasifiers with a wide range of agricultural wastes has already been demonstrated in previous gasification research<sup>13, 22, 27</sup>. In rural areas, agricultural wastes could be obtained at little or no cost during some seasons. These supplemental biomass fuels would increase the utilization of the system. The fate of pesticide residues in the gasification process must be defined, before this option can be considered operational.

## CONCLUSIONS AND RECOMMENDATIONS FOR FUTURE RESEARCH

Conclusions derived from this work and recommendations for future research are presented below.

### Conclusions

Based on the experimental work the following conclusions can be drawn:

1. The co-disposal of densified sludge/solid waste mixtures appears to be technically feasible.
2. The preparation of densified sludge/solid waste mixtures at a full scale pilot facility has been demonstrated.
3. A pilot scale gasifier was constructed and operated with densified mixtures of sludge and source separated solid waste. Low energy gas was produced during the tests with an energy content ranging from 5.02 to 5.08 mJ/m<sup>3</sup>, at conversion efficiencies from 67 to 73 percent.
4. Other than a lower gasification rate relative to biomass fuels, no operational problems were experienced with sludge/solid waste fuels. However, some slag formation was noted in the gasifier firebox.
5. The co-gasification of densified sludge and source separated solid waste may be a new approach to co-disposal that could be used by both large and small communities.

### Recommendations for Future Research

Although the technical feasibility of operating a packed bed gasifier with densified sludge/solid waste mixtures has been demonstrated, several key issues must be addressed in future work before the co-gasification process can be considered operational on a routine basis. They are:

1. What are the optimum conditions for gasifier operation in terms of fuel consumption, air flow, gas quality, and efficiency? These parameters must be defined to develop loading factors and specifications for the design of full scale systems.
2. What conditions cause slagging? Slag control measures such as steam or water injection, or continuous grate rotation should be investigated.
3. What is the fate of heavy metals during the gasification process?
4. What is the mass emission rate and the size distribution for particulates in the low energy gas?
5. The economics of the co-gasification process for small communities must be delineated. The effect of landfill distance, tipping fees, and operating costs of a source separation system should be included in the analysis.
6. Manufacturers of appropriate system components must be identified.

### ACKNOWLEDGMENT

The assistance of R. Ault, J. Goss, B. Jenkins, J.J. Mehlshau, N. Raubach, and C.J Redding of the Department of Agricultural Engineering, University of California, Davis is gratefully acknowledged. The technical assistance of D. Vaughn, Cal-Cube Corporation, and G. Nelson, Papakube Corporation is also gratefully appreciated. Operation of the gasifier and conduct of laboratory analyses were assisted by D.A. Bartley, D. Davis, R. Healy,

and N. Sorbo, graduate students in the Department of Civil Engineering, University of California, Davis.

This research was co-sponsored by the Department of Civil Engineering, University of California, Davis; the Municipal Environmental Research Laboratory, U.S. Environmental Protection Agency (Grant No. R-805-70-3010), Project Officer, Howard Wall; Department of Civil Engineering, University of California, Davis; and the University of California Appropriate Technology Program (Grant No. 78-2-15, 000), Director, Professor David J. Hills. Publication of this research does not signify that the contents reflect the views and policies of the U.S. Environmental Protection Agency or the University of California, nor does mention of trade names or commercial products constitute endorsement or recommendation for use.

This research was submitted in partial fulfillment of the requirements for the Doctor of Philosophy Degree in Engineering to the Graduate Division, University of California, Davis.

### AUTHORS

Samuel A. Vigil, and George Tchobanoglous are, respectively, associate development engineer, and professor in the Department of Civil Engineering at the University of California, Davis.

### REFERENCES

1. Jones, J.L., "Converting Solid Wastes and Residues to Fuel", Chemical Engineering, Jan. 2, 1978, McGraw-Hill Inc. New York, pp. 87-94 (Jan. 1978).
2. Lewis, F.M., "Thermodynamic Fundamentals for the Pyrolysis of Refuse," in Proceedings 1976 National Waste Processing Conference, Boston, May 23-26, 1976, American Society of Mechanical Engineers, New York, N.Y.(1976)
3. Skov, N.A. and M.L. Papworth, The PEGASUS Unit - Petroleum/Gasoline Substitute Systems, Pegasus Publishers, Inc., Olympia, Washington (1974).
4. Nordstrom, O., "Redogorelse for Riksnamndens for ekonomich forsvar sberedskap forskingsock fursosverksamhet pa gengasomradet rid statens maskinpravnigar 1957-1963", Chapters 1-5, Obtainable from National Swedish Testing Institute for Agricultural Machinery, Box 7035, 75007 Uppsala, Sweden, (in Swedish), (1963).
5. Fisher, T.F., M.L. Kasbohm, and J.R. Rivero, "The PUROX System," in Proceedings 1976 National Waste Processing Conference, Boston, May 23-26, 1976, American Society of Mechanical Engineers, New York, N.Y. (1976).
6. Lombana, L.A., and J.G. Campos, "Incineration Method and System," U.S. Patent No. 4,013,023 (Mar. 1977).
7. Eggen, A.C.W., and R. Kraatz, "Gasification of Solid Wastes in Fixed Beds," ASME Paper 74-WA/Pwr-10, Presented at the Winter Annual Meeting, American Society of Mechanical Engineering, New York, N.Y. (Nov. 1974).

8. Gumz, W., Gas Producers and Blast Furnaces - Theory and Methods of Calculation, John Wiley and Sons, Inc., New York, N.Y. (1950).
9. Hoffman, E.J., Coal Conversion, The Energon Co., Laramie, Wyoming (1978).
10. "A Survey of Biomass Gasification, Volume II - Principles of Gasification," Report No. SERI/TR-33-239, Solar Energy Research Institute, Golden, Colorado (1979).
11. Golodetz, D., "Look to Co-disposal - The Waste Handling Method of the Future," Water and Wastes Engineering, pp. 71-76 (Sept. 1979).
12. Jantunen, M., and D. Asplund, "Peat Gasification Experiments and the Use of Gas in a Diesel Engine," Technical Research Center of Finland, Fuel and Lubricant Research Laboratory, Espoo, Finland (1979).
13. Williams, R.O., J.R. Goss, J.J. Mehlschau, B. Jenkins, and J. Ramming, "Development of Pilot Plant Gasification Systems for the Conversion of Crop and Wood Residues to Thermal and Electrical Energy," in Solid Wastes and Residues Conversion by Advanced Thermal Processes, J.L. Jones, and S.B. Radding, Editors, ACS Symposium Series, American Chemical Society, Washington, D.C., pp. 142-162 (1978).
14. Hollander, H.I. and N.F. Cunningham, "Beneficiated Solid Waste Cubettes as Salvage Fuel for Steam Generation," in Proceedings 1972 National Incinerator Conference, New York City, June 4-7, 1972, American Society of Mechanical Engineers, New York, N.Y. (1972).
15. Nelson, G.B., "Stable Blocks Formed of Shredded Paper-Like Material," U.S. Patent No. 3,949,036 (Apr. 1976).
16. Nelson, G.B., and G.C. Nelson, "Briquetting of Organic Material for Feed and Fuel," presented before the Bi-Annual Meeting of the Institute of Briquetting and Agglomeration, San Diego (1979).
17. Vigil, S.A., "Co-gasification of Densified Sludge and Solid Waste in a Downdraft Gasifier," PhD Thesis, University of California, Davis (1980).
18. Jenkins, B.M., "Downdraft Gasification Characteristics of Major California Residue - Derived Fuels," PhD Thesis, University of California, Davis (1980).
19. Vigil, S.A., D.A. Bartley, R. Healy, and G. Tchobanoglous, "Operation of a Downdraft Gasifier Fueled With Source Separated Solid Waste," Presented at the Symposium on Thermal Conversion of Solid Wastes and Biomass, 178th American Chemical Society Annual Meeting, Washington, D.C. (Sept. 1979).
20. Vigil, S.A., G. Tchobanoglous, and E.D. Schroeder, "Application of Packed Bed Gasifiers to the Reduction of Solid Wastes and the Recovery of Energy," in Proceedings of the ASCE Environmental Engineering Division Specialty Conference, San Francisco, California, American Society of Civil Engineers, New York, N.Y., (July 1979).
21. Miles, T.R., and T.R. Miles Jr., "Densification Systems for Agricultural Residues," Presented at the Symposium on Thermal Conversion of Solid Wastes and Biomass, 178th American Chemical Society Annual Meeting, Washington, D.C. (Sept. 1979).

22. Williams, R.O., and J.R. Goss, "An Assessment of the Gasification Characteristics of Some Agricultural and Forest Industry Residues Using a Laboratory Gasifier," Resource Recovery and Conservation, 3, pp. 317-329 (1979).
23. Cruz, I.E., "Producer Gas from Agricultural Wastes - Its Production and Utilization in a Converted Oil-Fired Boiler," Resource Recovery and Conservation, 2(1976/1977), p. 241-256, Elsevier Scientific Publishing Company, Amsterdam (1977).
24. Maurer, R.E., and D. Lonick, "Firsthand Look at Coal Gasifiers," Instruments and Control Systems (Aug. 1979).
25. Goss, J.R., "Interim Report - Pilot Plant Gasification Tests," Department of Agricultural Engineering, University of California, Davis, (Jan. 1979).
26. "Co-disposal of Garbage and Sewage Sludge - A Promising Solution to Two Problems," GAO Report No. CED-79-59, U.S. General Accounting Office, Washington, D.C. (May 1979).
27. Williams, R.O., and B. Horsfield, "Generation of Low-BTU Fuel Gas From Agricultural Residues - Experiments with a Laboratory Scale Gas Producer," in Food, Fertilizer, and Agricultural Residues - Proceeding of the 1977 Cornell Agricultural Waste Management Conference, Ann Arbor Science Publishers, Inc., Ann Arbor (1977).