

3-20-91
E6006

NASA Technical Memorandum 103777

Thermal Shock of Fiber Reinforced Ceramic Matrix Composites

Andrew J. Eckel
Lewis Research Center
Cleveland, Ohio

John Z. Gyekenyesi
Cleveland State University
Cleveland, Ohio

Thomas P. Herbell and Edward R. Generazio
Lewis Research Center
Cleveland, Ohio

Prepared for the
15th Annual Conference on Composites and Advanced Ceramics
sponsored by the American Ceramic Society
Cocoa Beach, Florida, January 13-16, 1991

NASA

Trade names or manufacturers' names are used in this report for identification only. This usage does not constitute an official endorsement, either expressed or implied, by the National Aeronautics and Space Administration.

THERMAL SHOCK OF FIBER REINFORCED CERAMIC MATRIX COMPOSITES

Andrew J. Eckel
National Aeronautics and Space Administration
Lewis Research Center
Cleveland, Ohio 44135

John Z. Gyekenyesi
Cleveland State University
Cleveland, Ohio 44115

Thomas P. Herbell and Edward R. Generazio
National Aeronautics and Space Administration
Lewis Research Center
Cleveland, Ohio 44135

ABSTRACT

Monolithic silicon carbide and silicon nitride and a Nicalon fiber reinforced silicon carbide composite were subjected to severe thermal shock conditions via impingement of a hydrogen/oxygen flame. Surface heating rates of 1000 °C/sec to 2500 °C/sec were generated. The performance of the monolithic reference materials are compared and contrasted with the significantly greater thermal shock resistance of the composite. Ultrasonic and radiographic NDE techniques were used to evaluate integrity of the composite subsequent to thermal shock. Tensile tests were performed to determine the residual tensile strength and modulus. Physical property changes are discussed as a function of number and severity of thermal shock cycles.

INTRODUCTION

Continuous fiber reinforced ceramic matrix composites (FRCMCs) offer the potential for significant performance gains, reliability increases and cost savings over materials currently used in rocket engine turbopump components.¹⁻⁴ These improvements are a result of higher temperature capability, lower densities, and generally greater resistance to environmental degradation. The severe thermal transients of a rocket engine environment makes thermal shock resistance of primary concern for ceramic

and other materials. For example, the high pressure fuel turbopump (HPFTP) of a space shuttle main engine (SSME) undergoes two thermal transients within the first 2 sec of operation before rising to the steady-state value of near 870 °C (1600 °C).⁵ The time-temperature profiles of these spikes are seen in Fig. 1. Temperature excursions of these magnitudes are known to result in cracking of monolithic ceramic materials.⁶ The SSME thermal transients are also believed to contribute to the formation and/or propagation of cracks in the currently used metallic HPFTP blades.

Carpenter⁴ has shown that properly designed monolithic ceramic components have the potential to survive the steady-state operating conditions of an advanced rocket engine turbopump. However, a major concern with monolithic ceramics is their lack of toughness which can lead to a brittle catastrophic type of failure. FRCMCs exhibit significantly greater fracture toughness than monolithic ceramics. This higher toughness, which results in greater reliability, might also be expected to result in ceramic materials which have a greater resistance to thermal shock. The development of FRCMC is, however, far less mature than for monolithic ceramics. There is only a limited mechanical property database, and little or no information in the literature on the thermal shock resistance of FRCMCs.

This paper provides some preliminary data on the performance of selected FRCMC coupons subjected to thermal shock in a rocket engine test stand. The results for the FRCMCs are compared to the performance of monolithic silicon nitride (Si_3N_4) and silicon carbide (SiC) ceramics. Damage due to thermal shock was assessed by employing x-radiographic and ultrasonic techniques and tensile tests for measurement of retained modulus and strength.

To further evaluate the applicability of FRCMCs in a rocket engine turbopump environment, two FRCMC airfoil shaped components were subjected to multiple thermal shock cycles in the same test rig.

MATERIALS

The monolithic materials were all obtained commercially. Silicon carbide and silicon nitride were chosen as the baseline monolithic ceramics since these materials are relatively mature and are currently

either being used or are serious contenders for use in other high temperature heat engine applications. All of the monolithic materials were machined in rectangular configurations of approximately 3 x 12.7 x 76 mm.

The FRCMC coupon materials evaluated in this study were composites fabricated of plain woven Nicalon⁺ fibers in a 2-D laminated chemically vapor infiltrated (CVI) SiC matrix. Two geometries were used for the ceramic composite coupons. One was identical to the monolithic sample geometry given above, and one had a reduced gauge section (8.4 mm). The samples are seen in Fig. 2. Table I lists some of the physical and mechanical properties of the composites, as provided by the manufacturer. A representative cross-sectional microstructure of the composites is seen in Fig. 3.

The airfoil shaped composites were fabricated to simulate turbine blades for a rocket engine turbopump and are seen in Fig. 4. One blade (marked A in Fig. 4) was fabricated of SiC (Avco SCS-6) fibers in a hot pressed silicon nitride matrix. It was machined into the final shape and thus had exposed fibers. The second airfoil shape (B) was fabricated of woven graphite fibers reinforcing a CVI SiC matrix. The blade pair was cut into two single blades, and each was tested separately. There were no exposed fibers in the blade section of these components.

PROCEDURE

The thermal shock tests were conducted by employing a stationary 1000 lb thrust hydrogen/oxygen rocket engine mounted in a horizontal position. The details of this specific engine, its characterization and operation are as described by Brindley and Nesbitt.⁷ These authors have also shown that the thermal shock condition produced by this NASA Lewis rocket engine test rig approximates that currently experienced in the SSME turbopumps.

The rectangular coupon and tensile test specimens were positioned at the exit of the engine such that an edge of the bar was directly exposed to the rocket exhaust, as indicated in Fig. 5. The chamber

⁺ A Si-C-O fiber manufactured by Nippon Carbon Company, Tokyo, Japan.

pressure and corresponding gas pressure applied to the leading edge of the samples was approximately 100 psi. The coupons were held lightly on each end via a force applied normal to the flat side of the sample. This configuration resulted in the most severe thermal shock being applied to the center section of the sample, with the ends remaining "cold".

The thermal shock test is conducted by 1 sec pulses of the engine. A typical temperature-time profile of the engine gas temperature and the approximate temperature on the hot side of a sample, during one cycle, are shown in Fig. 6. Altering the oxygen/hydrogen ratio allows control of the thermal shock temperature (ΔT in Fig. 6) from 1000 to 2500 °C in the 1 sec test. All of the tests are filmed at 400 frames per second to facilitate review of any significant events during the tests.

All of the FRCMC test bars were examined ultrasonically and by x-radiographic techniques prior and subsequent to thermal shock. Both the FRCMC rectangular coupons and the "dog-bone" test bars were tensile tested after thermal shock tests.

The airfoil shaped components were tested by mounting them in a cantilevered fashion in the exhaust. The specimens were held such that 14.3 mm (9/16 in.) was directly in the exhaust. The components were positioned such that the gas impinged on the concave side of the turbine blade shape.

RESULTS AND DISCUSSION

Monolithic Ceramics

The results for the monolithic ceramic coupons have been reported elsewhere^{8,9} and are summarized as follows.

A total of 22 bars of 3 types of SiC (sintered alpha SiC, hot-pressed SiC and reaction bonded SiC) and 31 bars of Si₃N₄ (sintered alpha Si₃N₄, hot-pressed Si₃N₄ and reaction bonded Si₃N₄) were tested at various heat-up rates. The maximum ΔT without visible damage achieved for any of the materials was 1500 °C (2730 °F). Most of the samples failed during the cool-down portion of the thermal shock cycle. When a sample survived more than one cycle, it usually failed on ignition of a subsequent run. This would indicate that the critical crack was probably initiated during the cool-down portion of the previous

cycle. The fact that the samples failed during the cool-down portion of the cycle would indicate that failure was caused by tensile forces generated at the sample surface.

The Si_3N_4 generally lasted a greater number of cycles than the SiC. For example, the average number of cycles to failure in the thermal shock condition of ΔT equal to 1400°C (2550°F) was 3.5 for Si_3N_4 . This compares to 1.5 cycles for monolithic SiC. This result is consistent with predicted performance.⁶

Nicalon/Silicon Carbide Composites

The FRCMC samples were tested at thermal shock ΔT ranging from 1300°C (2370°F) to 2300°C (4170°F). In contrast to the monolithic materials, none of the composites failed catastrophically -- even at the most severe test conditions! The retained ultimate tensile strength of the FRCMC samples as a function of severity and number of thermal shock cycles is seen in Fig. 7. There was no significant strength variation between the rectangular coupons and the "dog-bone" tensile bars following identical thermal shock tests.

The tensile strength data shows little or no decrease in tensile strength for thermal shock ΔT 's up to 1700°C . There was also no degradation detected by x-radiographic or ultrasonic analysis. This thermal shock condition is greater than that of the current SSME turbopump.⁵ At ΔT 's equal to 1900°C the strength is seen to fall off with increasing number of thermal shock cycles. In these samples degradation was clearly visible in the form of physical erosion of the leading edge of the samples. For example, the cross-sectional area of the sample subjected to 25 cycles to 1900°C was reduced by greater than 40 percent. Despite this significant degradation, the sample still maintained 65 percent of its tensile strength. This qualitatively demonstrates both the thermal shock resistance and notch-insensitivity of this composite material.

For the samples subjected to ΔT 's of 1900°C , the decrease in ultimate tensile strength was accompanied by reduced linear elastic strain behavior. The matrix cracking stress generally decreased with increasing number of thermal shock cycles. This is a result of increasing quantity of matrix cracking.

However, due to scatter and the small number of samples subjected to these conditions, this was only a qualitative observation.

FRCMC Airfoil Components

The turbine airfoil shapes also performed well in the thermal shock tests. A SiC fiber reinforced Si_3N_4 component was subjected to 10 cycles of at least 1800 °C each. No structural damage was noted for this material, but oxidation of the fibers and matrix was observed. A graphite fiber reinforced SiC blade was subjected to more than 60 cycles of at least 1800 °C each. No visible damage was observed until after 20 cycles were completed. During the 20th cycle a small amount of chipping of the leading edge material was observed. Following this, the only further damage was minor progressive erosion of the leading edge. These qualitative results for the turbine airfoil shapes are highly significant and demonstrate the viability of applying FRCMCs in the turbopump of advanced rocket engines.

SUMMARY

This preliminary evaluation of the thermal shock resistance of FRCMCs in a rocket engine environment has demonstrated their superior capabilities relative to monolithic ceramic materials. Monolithic SiC and Si_3N_4 were observed to fail catastrophically in the simulated rocket engine turbopump environment. In contrast, FRCMC coupons showed little or no damage at similar test conditions, and only a progression of degradation at the most severe thermal shock conditions.

The composites retained their room temperature tensile strength following up to 50 one-second thermal shock cycles at a ΔT equal to 1700 °C. At a ΔT equal to 1900 °C, the retained strength decreased with increasing number of cycles.

CONCLUSION

Fiber reinforced ceramic matrix composites appear to have the thermal shock resistance necessary for application in advanced rocket engine turbopumps. Future studies will focus on composite architecture effects and actual or simulated turbopump tests under transient and steady-state conditions.

REFERENCES

1. J.W. Brockmeyer and G.D. Schnittgrund, "Ceramic Composites for Advanced Earth-to-Orbit Rocket Engine Turbines," pp. 214-227 in Proceedings of 1990 Conference on Advanced Earth-To-Orbit Propulsion Technology, NASA Marshall Space Flight Center, Huntsville, AL, May 15-18, 1990. NASA CP-3092, Vol. I.
2. D. Carper, R. Eskridge, G.M. Holloway, C. Quinn, S. Ward, G. Wu, and R. Singh, "Ceramic Composites for Advanced Earth-to-Orbit Rocket Engine Turbines," pp. 200-214 in Proceedings of 1990 Conference on Advanced Earth-To-Orbit Propulsion Technology, NASA Marshall Space Flight Center, Huntsville, AL, May 15-18, 1990. NASA CP-3092, Vol. I.
3. W.T. Chandler, "Materials for Advanced Rocket Turbopump Turbine Blades", Final Report Contract NAS3-23536, Rockwell International Report RI/RD83-207, 1983.
4. H.W. Carpenter, "Ceramic Turbine Elements," Final Report Contract NAS8-5327, Rockwell International Report RI/RD84-164, NASA CR-161989, June 1989.
5. A. Abdul-Aziz, M.T. Tong, and A. Kaufman, "Thermal-Finite-Element Analysis of Space Shuttle Main Engine Turbine Blade", NASA TM-100117, Oct. 1987.
6. W.D. Kingery, "Factors Affecting Thermal Stress Resistance of Ceramic Materials," J. Am. Ceram. Soc., 38 [1] 3-15 (1955).
7. W.J. Brindley, and J.A. Nesbitt, "Durability of Thermal Barrier Coatings in a High Heat Flux Environment" pp. 661-674 in Proceedings of 1988 Conference on Advanced Earth-To-Orbit Propulsion Technology, NASA Marshall Space Flight Center, Huntsville, AL, May 10-12, 1988. NASA CP-3012-V Vol. 1.
8. A.J. Eckel and T.P. Herbell, "Thermal Shock of Fiber Reinforced Ceramic Matrix Composites" The 13th Annual Conference on Metal Matrix, Carbon and Ceramic Matrix, J.D. Buckley, ed. NASA CP-3054, Part 1, p. 153-162, published 1990.

9. A.J. Eckel and T.P. Herbell, "Thermal Shock Stability of Selected Ceramic Composites in a Rocket Engine Environment," pp. 242-250 in Proceedings of 1990 Conference on Advanced Earth-To-Orbit Propulsion Technology, NASA Marshall Space Flight Center, Huntsville, AL, May 15-18, 1990. NASA CP-3092, Vol. 1.

TABLE I. - NICALON/SiC
COMPOSITE PHYSICAL
PROPERTIES

Nicalon fiber content	40 vol %
Porosity	10%
Density	2.5 g/cm ³
Tensile strength	200 MPa
Flexural strength	300 MPa
Tensile modulus	230 GPa
Fracture toughness	30 MPa m

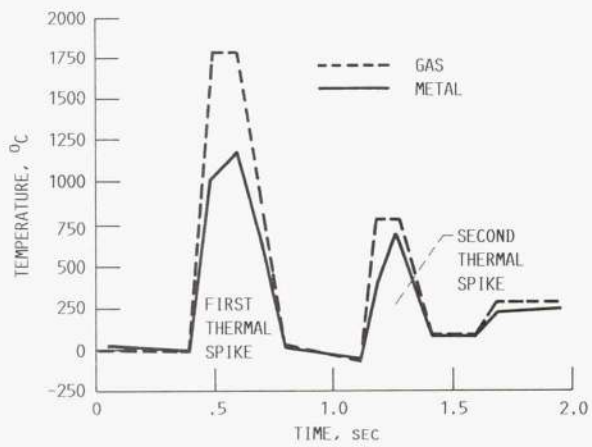

FIGURE 1. - GAS TEMPERATURE AND PREDICTED METAL TEMPERATURE ON LEADING EDGE OF FIRST STAGE TURBINE BLADE IN THE HPFTP DURING START-UP (REF. 5).

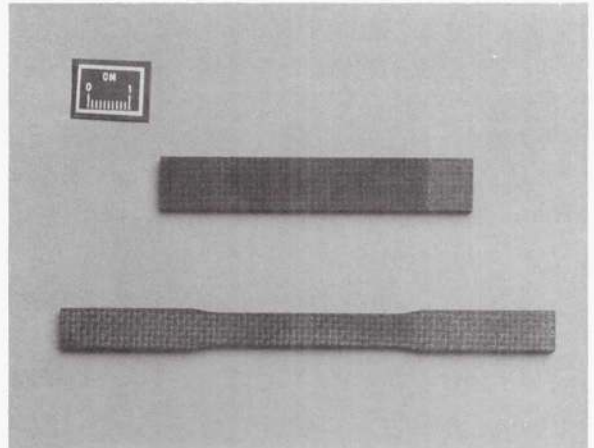

FIGURE 2. - FRCMC THERMAL SHOCK TEST COUPONS.

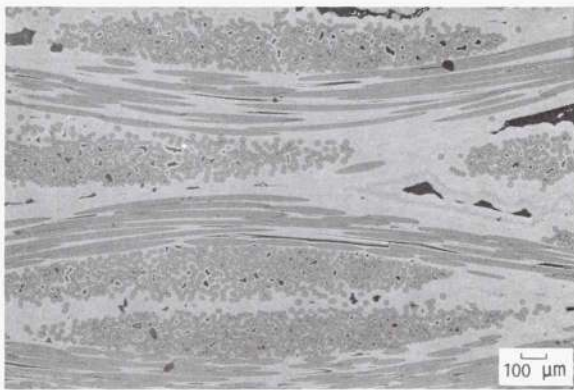

FIGURE 3. - REPRESENTATIVE MICROSTRUCTURE OF 2-D LAMINATED NICALON/SiC COMPOSITE.

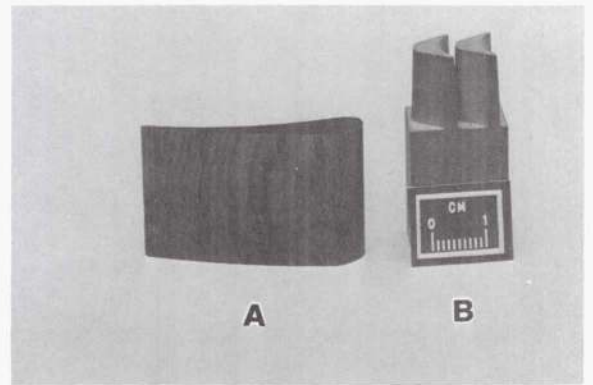

FIGURE 4. - FIBER REINFORCED CERAMIC MATRIX COMPOSITE TURBINE BLADES.

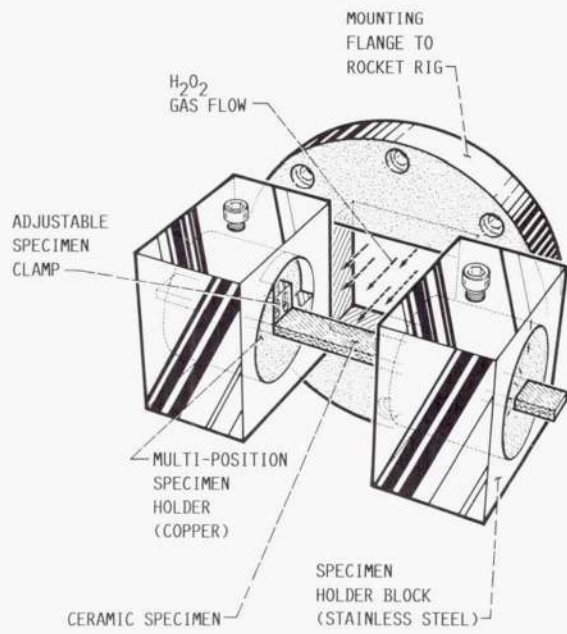

FIGURE 5. - SCHEMATIC OF ROCKET ENGINE SETUP USED FOR THERMAL SHOCK TESTING.

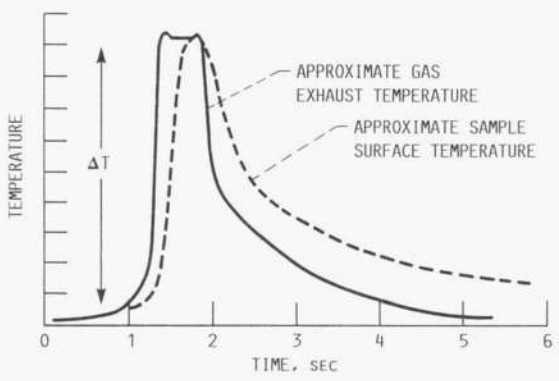

FIGURE 6. - TYPICAL TEMPERATURE-TIME PROFILE FOR ONE SECOND THERMAL SHOCK TEST.

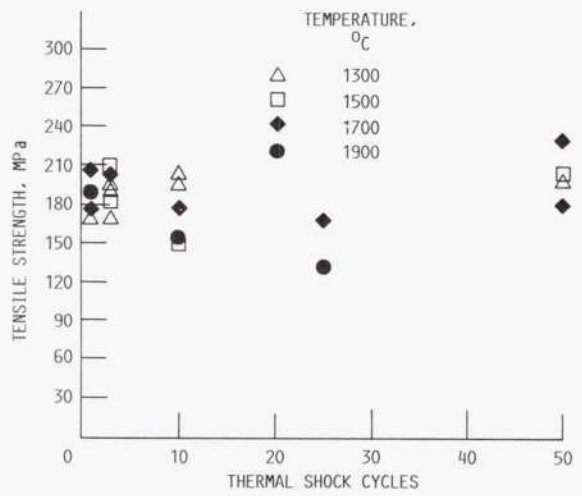

FIGURE 7. - RETAINED ROOM TEMPERATURE TENSILE STRENGTH OF NICALON/SiC CERAMIC COMPOSITES AFTER THERMAL SHOCK.



National Aeronautics and
Space Administration

Report Documentation Page

1. Report No. NASA TM-103777		2. Government Accession No.		3. Recipient's Catalog No.	
4. Title and Subtitle Thermal Shock of Fiber Reinforced Ceramic Matrix Composites				5. Report Date	
				6. Performing Organization Code	
7. Author(s) Andrew J. Eckel, John Z. Gyekenyesi, Thomas P. Herbell, and Edward R. Generazio				8. Performing Organization Report No. E-6006	
				10. Work Unit No. 590-21-11	
9. Performing Organization Name and Address National Aeronautics and Space Administration Lewis Research Center Cleveland, Ohio 44135-3191				11. Contract or Grant No.	
				13. Type of Report and Period Covered Technical Memorandum	
12. Sponsoring Agency Name and Address National Aeronautics and Space Administration Washington, D.C. 20546-0001				14. Sponsoring Agency Code	
15. Supplementary Notes Prepared for the 15th Annual Conference on Composites and Advanced Ceramics sponsored by the American Ceramic Society, Cocoa Beach, Florida, January 13-16, 1991. Andrew J. Eckel, NASA Lewis Research Center; John Z. Gyekenyesi, Cleveland State University, Cleveland, Ohio 44115; Thomas P. Herbell and Edward P. Generazio, NASA Lewis Research Center. Responsible person, Andrew J. Eckel, (216) 433-8185.					
16. Abstract Monolithic silicon carbide and silicon nitride and a Nicalon fiber reinforced silicon carbide composite were subjected to severe thermal shock conditions via impingement of a hydrogen/oxygen flame. Surface heating rates of 1000 °C/sec to 2500 °C/sec were generated. The performance of the monolithic reference materials are compared and contrasted with the significantly greater thermal shock resistance of the composite. Ultrasonic and radiographic NDE techniques were used to evaluate integrity of the composite subsequent to thermal shock. Tensile tests were performed to determine the residual tensile strength and modulus. Physical property changes are discussed as a function of number and severity of thermal shock cycles.					
17. Key Words (Suggested by Author(s)) Thermal shock, Ceramic matrix composite, Rocket engine turbopump			18. Distribution Statement Unclassified - Unlimited Subject Category 27		
19. Security Classif. (of the report) Unclassified		20. Security Classif. (of this page) Unclassified		21. No. of pages 12	22. Price* A03