

The public reporting burden for this collection of information is estimated to average 1 hour per response, including the time for reviewing instructions, searching existing data sources, gathering and maintaining the data needed, and completing and reviewing the collection of information. Send comments regarding this burden estimate or any other aspect of this collection of information, including suggestions for reducing this burden, to Washington Headquarters Services, Directorate for Information Operations and Reports, 1215 Jefferson Davis Highway, Suite 1204, Arlington VA, 22202-4302. Respondents should be aware that notwithstanding any other provision of law, no person shall be subject to any penalty for failing to comply with a collection of information if it does not display a currently valid OMB control number.
PLEASE DO NOT RETURN YOUR FORM TO THE ABOVE ADDRESS.

1. REPORT DATE (DD-MM-YYYY) 11-08-2014	2. REPORT TYPE Final Report	3. DATES COVERED (From - To) 13-Sep-2010 - 12-Mar-2014
---	--------------------------------	---

4. TITLE AND SUBTITLE Final Report: Thermo-inelastic Response of Polymeric Solids	5a. CONTRACT NUMBER W911NF-10-1-0457
	5b. GRANT NUMBER
	5c. PROGRAM ELEMENT NUMBER 611102

6. AUTHORS K. R. Rajagopal, A. R. Srinivasa	5d. PROJECT NUMBER
	5e. TASK NUMBER
	5f. WORK UNIT NUMBER

7. PERFORMING ORGANIZATION NAMES AND ADDRESSES Texas Engineering Experiment Station 400 Harvey Mitchell Parkway South Suite 300 College Station, TX 77845 -4375	8. PERFORMING ORGANIZATION REPORT NUMBER
---	--

9. SPONSORING/MONITORING AGENCY NAME(S) AND ADDRESS (ES) U.S. Army Research Office P.O. Box 12211 Research Triangle Park, NC 27709-2211	10. SPONSOR/MONITOR'S ACRONYM(S) ARO
	11. SPONSOR/MONITOR'S REPORT NUMBER(S) 56022-EG.3

12. DISTRIBUTION AVAILABILITY STATEMENT Approved for Public Release; Distribution Unlimited
--

13. SUPPLEMENTARY NOTES The views, opinions and/or findings contained in this report are those of the author(s) and should not be construed as an official Department of the Army position, policy or decision, unless so designated by other documentation.

14. ABSTRACT We the study the impact response of a large layered viscoelastic plate by subjecting it to a variety of inputs at one end of plate while the other end is fixed. The nonlinear response of the material is modeled using an implicit two network theory. A finite volume technique is used to solve the momentum equation together with a one-step explicit scheme for the time evaluation and in order to capture the wave propagation phenomena. Polymethylmethacrylate (PMMA) and Polycarbonate (PC) are used in this study. Results indicate that the stress on the wall was lowest when using a trilayer (DMMA/PC/DMMA). Such problems have relevance to several

15. SUBJECT TERMS Impact, viscoelasticity, amorphous polymers, wave propagation, implicit constitutive relations, finite volume method

16. SECURITY CLASSIFICATION OF:	17. LIMITATION OF ABSTRACT	15. NUMBER OF PAGES	19a. NAME OF RESPONSIBLE PERSON K. Rajagopal
a. REPORT UU	UU		19b. TELEPHONE NUMBER 979-862-4552
b. ABSTRACT UU			
c. THIS PAGE UU			

Report Title

Final Report: Thermo-inelastic Response of Polymeric Solids

ABSTRACT

We study the impact response of a large layered viscoelastic plate by subjecting it to a variety of inputs at one end of plate while the other end is fixed. The nonlinear response of the material is modeled using an implicit two network theory. A finite volume technique is used to solve the momentum equation together with a one-step explicit scheme for the time evaluation and in order to capture the wave propagation phenomena. Polymethylmethacrylate (PMMA) and Polycarbonate (PC) are used in this study. Results indicate that the stress on the wall was lowest when using a trilayer (PMMA/PC/PMMA). Such problems have relevance to several applications including blast protection and wave attenuation.

The parameters characterizing the model were obtained from the creep compliance data found in the literature. The reflected and the transmitted wave characteristics for the layered materials were studied using the model. The study can be viewed as a significant step in the determination the shock absorbing characteristics of composite layers made of polymeric materials and the model and the method used in this study serve as a tool for selecting better impact resistant composite bodies.

Enter List of papers submitted or published that acknowledge ARO support from the start of the project to the date of this printing. List the papers, including journal references, in the following categories:

(a) Papers published in peer-reviewed journals (N/A for none)

<u>Received</u>	<u>Paper</u>
08/11/2014	1.00 P. Alagappan, K.R. Rajagopal, A.R. Srinivasa. Wave propagation due to impact through layered polymer composites, Composite Structures, (08 2014): 1. doi: 10.1016/j.compstruct.2014.03.037
TOTAL:	1

Number of Papers published in peer-reviewed journals:

(b) Papers published in non-peer-reviewed journals (N/A for none)

<u>Received</u>	<u>Paper</u>
TOTAL:	

Number of Papers published in non peer-reviewed journals:

(c) Presentations

Challenges and opportunities in the modeling of thermo-viscoelastic materials, Society of Experimental Mechanics, Greenville, North, Carolina, June 2014 (Presented by A. R. Srinivasa).

Challenges and opportunities in the modeling of thermo-viscoelastic materials, Department of Engineering Design, Indian Institute of Technology, Madras, July 2014 (Presented by A. R. Srinivasa).

Number of Presentations: 2.00

Non Peer-Reviewed Conference Proceeding publications (other than abstracts):

Received Paper

TOTAL:

Number of Non Peer-Reviewed Conference Proceeding publications (other than abstracts):

Peer-Reviewed Conference Proceeding publications (other than abstracts):

Received Paper

TOTAL:

Number of Peer-Reviewed Conference Proceeding publications (other than abstracts):

(d) Manuscripts

Received Paper

08/11/2014 2.00 . DYNAMIC RESPONSE OF VISCOELASTIC SOLIDS DESCRIBED BY IMPLICIT CONSTITUTIVE THEORIES,
()

TOTAL: 1

Number of Manuscripts:

Books

Received Book

TOTAL:

Received Book Chapter

TOTAL:

Patents Submitted

Patents Awarded

Awards

None

Graduate Students

<u>NAME</u>	<u>PERCENT SUPPORTED</u>	<u>Discipline</u>
P. Alagappan	1.00	
FTE Equivalent:	1.00	
Total Number:	1	

Names of Post Doctorates

<u>NAME</u>	<u>PERCENT SUPPORTED</u>
FTE Equivalent:	
Total Number:	

Names of Faculty Supported

<u>NAME</u>	<u>PERCENT SUPPORTED</u>	National Academy Member
K. R. Rajagopal	0.10	No
A. R. Srinivasa	0.10	
FTE Equivalent:	0.20	
Total Number:	2	

Names of Under Graduate students supported

<u>NAME</u>	<u>PERCENT SUPPORTED</u>
FTE Equivalent:	
Total Number:	

Student Metrics

This section only applies to graduating undergraduates supported by this agreement in this reporting period

The number of undergraduates funded by this agreement who graduated during this period: 0.00

The number of undergraduates funded by this agreement who graduated during this period with a degree in science, mathematics, engineering, or technology fields:..... 0.00

The number of undergraduates funded by your agreement who graduated during this period and will continue to pursue a graduate or Ph.D. degree in science, mathematics, engineering, or technology fields:..... 0.00

Number of graduating undergraduates who achieved a 3.5 GPA to 4.0 (4.0 max scale):..... 0.00

Number of graduating undergraduates funded by a DoD funded Center of Excellence grant for Education, Research and Engineering:..... 0.00

The number of undergraduates funded by your agreement who graduated during this period and intend to work for the Department of Defense 0.00

The number of undergraduates funded by your agreement who graduated during this period and will receive scholarships or fellowships for further studies in science, mathematics, engineering or technology fields:..... 0.00

Names of Personnel receiving masters degrees

<u>NAME</u>
Total Number:

Names of personnel receiving PHDs

<u>NAME</u>
Total Number:

Names of other research staff

<u>NAME</u>	<u>PERCENT SUPPORTED</u>
FTE Equivalent:	
Total Number:	

Sub Contractors (DD882)

Inventions (DD882)

Scientific Progress

See attachment below

Technology Transfer

None.

Research Findings and Accomplishments

Alagappan Ponnalagu,

K. R. Rajagopal,

and Arun R. Srinivasa.

A. Introduction

Polymers composites are used as a protection against ballistic impact for the buildings and military vehicles. The main function of an armor is to make the impact of the projectile to cause no damage to the functionality of the structure. Initially when the armors were made this function was performed by putting a large mass on all the vulnerable regions. It works on the principle of conservation of momentum. The buildings were protected by using cheap material with high thickness. The drawback of this approach is that in order to meet higher intensity blasts more material must be used and this resulted in further increase in the weight. This results in more difficulty in the transportation of these material and reduction in the speed of the vehicles. When designing armor weight started to play a important role added to functionality. Hence the need for the use of the lightweight structures to perform the function arose. Polymer composites satisfied both the functionality and weight requirements. Nowadays these polymers are also used as coating for the building instead of the conventional thicker wall for the ballistic protection. There commercial polymers such as PAXCONTM, Dragonshield-HTTM, RhinoArmorTM which use polyurea(PU), polycarbonate(PC), polymethylmethacrylate (PMMA) etc. for the ballistic protection. For example, it can be seen from the figures 1 through 3 that spraying a coating of RhinoArmor protected the wall from the blast. From figure 4 it can be seen that Dragonshield-HT has been used as protective coating for military vehicles.

The hypothesis is that it is possible to use a two network theory to capture the essential features of a impact response of multilayered polymers and solve the resulting boundary value problem using finite volume scheme.

Traditionally in the explicit constitutive theory for the viscoelastic solids, the current stress is a functional of the strain history. As discussed by Rajagopal and Srinivasa [1] the use of this theory results in more difficulties in estimating the model parameters since it is impossible to

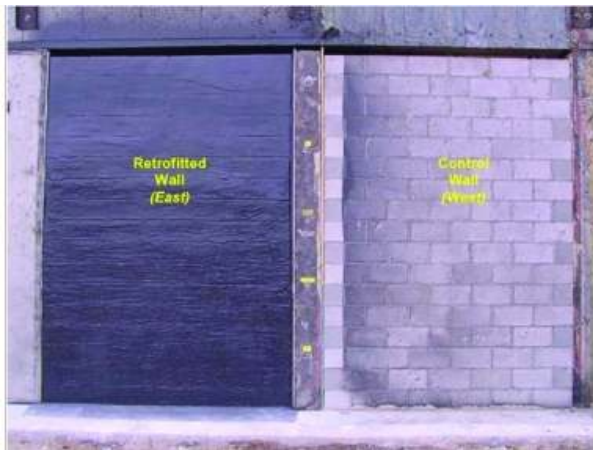

Fig. 1. Wall on the left is coated (RhinoArmor) and wall on right not coated



Fig. 2. Blast made in front of the wall

control the different components of strain and also most of the experiments are either partially or fully stress controlled. While, in the implicit constitutive theory there exists a functional relationship between the stress and strain. This representation has the following advantages

- The response functions of the model can be easily compared against experimental data and model parameters obtained.
- It results in simple ODE which is easily amenable to numerical scheme.

Hence, in this study we use a implicit constitutive theory for the mechanical response of a viscoelastic solids.

B. Advantages of using multilayered plates

Polymers such as PMMA, PC, PU etc. are layered together to improve the performance of structures which are subjected to impact loading[2, 3, 4, 5]. Many experimental and numerical studies have been carried out to study the response of polymers. For example experiments have shown that the performance of a bilayer plate under impact was improved by the presence of a polymeric material[5]. The performance depends not only upon the type of the polymeric



Fig. 3. The coated wall does not suffer any serious damage while the uncoated wall is broken completely exposing the interior.



Fig. 4. Polyurea coating to protect military vehicle

material but also upon the thicknesses and layering sequence. For example, bilayer experimental results in [2] suggests that the presence of a polymeric material on the impact side reduces the performance when compared to its presence on the other side. The presence of a compliant material between two stiff layers increases the performance by about 100% compared to the individual layers whereas a bilayer composite increases the performance by about 25% [5]. Sudden impact of these material results in the generation of waves and these waves gets attenuated, reflected and dispersed. The speed at which the wave moves depends upon the type of the material. Wave propagation through a homogenous material and layered composite are explained by considering a single wave (figures 5(a), 5(b) and 5(c)). In a homogenous material, the wave propagates in the same direction without any reflections but gets attenuated (figure 5(a)) and dispersed. In a layered composite, as the wave hits an interface 2, it partly gets reflected and partly gets transmitted. For example if we assume that the PMMA has a lower elastic modulus than PC, then the velocity of the transmitted wave is greater in PC (high elastic modulus) when compared to that of PMMA (low elastic modulus) which is represented schematically in figure 5(b) and 5(c). In order to study phenomena such as this, as well as to develop a tool that will enable us to quickly evaluate the impact resistance of different kinds

of polymers layered in a variety of ways, it is necessary to develop a physically realistic and computationally efficient model.

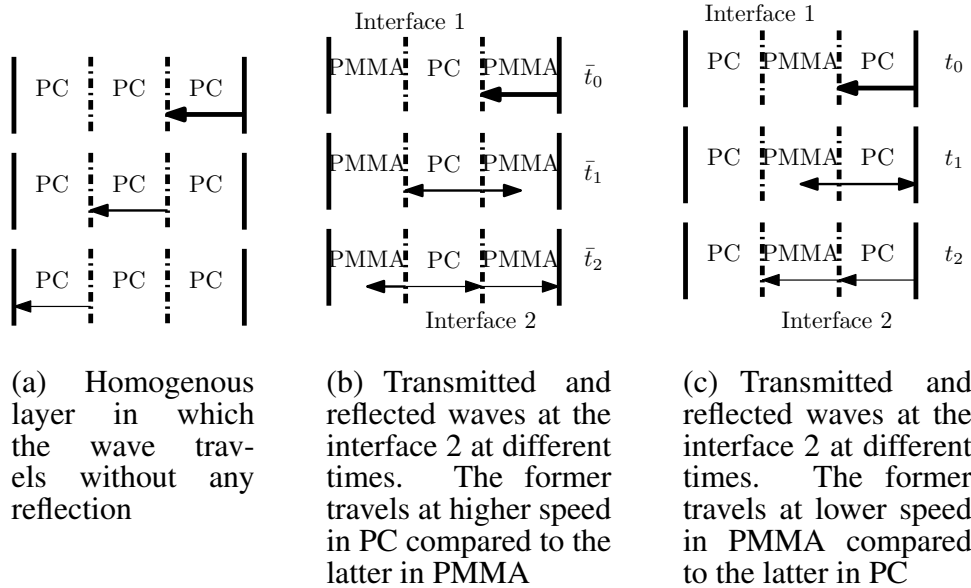

Fig. 5. Schematic representation of the propagation of a single wavefront in different material compositions. The location of the wavefront at the interfaces at three different times are shown by the arrows.

C. Numerical scheme

The Finite volume method(FVM) was used in this study to numerically solve the governing equations. In this procedure, the whole domain is divided into a finite number of non-overlapping control volumes. *For each control volume, the mass, momentum and energy balance equations are exactly met.* The constitutive equations are approximated by suitable interpolation schemes across neighbors. *With this approach, it is possible to meet local conservation of mass, energy and momentum and only the response functions are approximated.* In the finite element method(FEM) the local conservation is met only when the weighting function is independent of time or when using a discontinuous Galerkin method[6]. The finite volume method(FVM) has been very successful in computational fluid dynamics(CFD) but it has not

been extensively used like FEM in the area of solid mechanics. Studies have been carried out to predict the linear elastic behaviour of a incompressible elastic solid by using the finite volume method [7, 8]. This procedure was used to discretise the momentum balance and kinematic condition of incompressibility and hence the three dimensional small strain problem was solved using an algorithm similar to SIMPLETM[9]. The FVM was also used to calculate the stresses and displacement by Wheel [10] for the axisymmetric bodies. The stress equilibrium equations in terms displacement gradient was obtained by using the linear elastic constitutive equations and linear interpolations was used for the gradients. This procedure was also extended to solve small strain problems in linear viscoelastic solids to be used in applications involving heating or cooling of viscoelastic materials. The integral form of constitutive relation between stress and strain histories along with thermal effect was assumed and FVM was used to solve the momentum and energy balance equations[11]. Slone et al. [12] studied the dynamical structural response of linear elastic solids using three dimensional FVM and an implicit scheme for the time step. The discretisation method was similar to the previous studies. Studies discussed above used FVM to solve either linear elastic or linear viscoelastic solid problem. As discussed by the authors in the previous studies[7, 10, 11] FVM has the following advantages

- simple and efficient
- method is conservative on local and global scale
- simple to prescribe the boundary conditions

Hence in this study, we used FVM to solve the impact response of layered viscoelastic solids.

D. Modelling approach

The constitutive relations for viscoelastic materials are usually represented in two different forms – integral and differential/rate type[13]. In a typical integral model, the current value of the stress is given in terms of the integral of the history of the strain rate, with a kernel(usually called the relaxation modulus) that encodes the fading memory of the material. Simulating such a model is a challenge ([14]) because of the necessity of carrying the information about the history of the material response over time. In order to circumvent this, the relaxation moduli are usually represented as a sum of series of exponentials which is referred to as a Prony series([15, 16]). The Prony series have many parameters that are difficult to determine experimentally. In the case of non-linear integral models, the challenges are further exacerbated.

An alternative approach is the use of differential/rate type. The distinction between a differential and rate type model is based on the representation for the stress. The stress in the differential type model is defined explicitly in terms of appropriate kinematical variables and their derivatives. For the stress in rate type equations there is a relationship between the stress and its time derivatives and the kinematical variable and its time derivatives. Thus, fluids of grade n (see [17]) are referred to as differential type models while the Oldroyd-B fluid (see [18]) is referred to as a rate type model.

E. Wave Propagation

The equation of propagation of waves through a linearized elastic solid in one dimension is represented as

$$\rho \frac{\partial^2 u}{\partial t^2} = E \frac{\partial^2 u}{\partial x^2} \quad (0.1)$$

where u , ρ , E , x and t represent the displacement, density, elastic modulus, space and time domain respectively. D'Alembert solution to the above equation is of the form

$$u(x, t) = f(x - ct) + g(x + ct) \quad (0.2)$$

where c is velocity of propagation of the wave ($\sqrt{E/\rho}$). A similar approach was also used for viscoelastic solids in studies [3, 19, 20, 21, 22, 23, 24] which will be discussed.

Most of the models considered a linear viscoelastic model for describing wave propagation in the polymers because obtaining an analytical solution would be comparatively easier. Lee and Kanter [19] arrived at the solution of the wave propagation in a Maxwell fluid by comparing the governing equations of motion with the telegraphic equation which is given by

$$\frac{1}{LC} \frac{\partial^2 u}{\partial x^2} = \frac{\partial^2 u}{\partial t^2} + \left(\frac{R}{L} + \frac{G}{C} \right) \frac{\partial u}{\partial t} + \frac{GR}{LC} u \quad (0.3)$$

where u , R , L , G and C are voltage, resistance, inductance, conductance and capacitance respectively. The equations were solved using the Laplace transform technique resulting in a solution involving Bessel functions. Theocaris and Papadopoulou [20] considered the strain to be harmonic and solved the one dimensional wave equation for the displacement along the axis of the rod where the solutions involve attenuation and wave velocity parameters. The solution of the wave equation in this case involves two constants representing the direction of wave propagation i.e. one for the positive direction and the other for the negative direction. The two constants depend upon the frequency of the propagating wave. Fourier series was used to numerically calculate these constants. The impact response of polymeric materials was studied by assuming a linear viscoelastic relation for the polymeric material [21]. Musa [22] predicted the impact response by solving the governing equations of a linear viscoelastic material using Laplace transform. The scattering and dispersion of the stress waves was observed experimentally by Zhuang [23]. Experimental and numerical studies were carried out by Boteler et al. [3] to study the wave propagation in a polymer matrix composite subjected to impact. He

used the integral model and the Prony series to express the kernel was obtained from Zocher et al. [24] and used to predict the experimentally observed phenomenon of wave dispersion and attenuation. This model was able to capture the attenuation but not the dispersion.

Many models wherein a differential equation relates the strain and the stress can be obtained within the context of thermodynamics by assuming energy storage and energy dissipation mechanisms. From the point of view of one-dimensional modeling these energy storing and energy dissipation mechanisms can be viewed as elastic springs and viscous dashpots, respectively. Within the context of one dimensional nonlinear response, the combinations of linear springs and dashpots represent the energy storage and energy dissipative mechanisms, respectively[25]. In the development of three dimensional models, one dispenses with the idea of spring and dashpots but directly uses expression for the same from which the response relations can be derived (see [26, 27]). Such models are typically purely mechanical in nature and do not take into account thermomechanical phenomena. Rajagopal and Srinivasa [1, 28] have developed a three dimensional framework based on the maximisation of the rate of entropy production for thermoviscoelastic solids. The mechanical response of polymers is modelled by assuming it as a viscoelastic solid since it exhibits an instantaneous elastic response for a sudden application of load and creep behaviour when the load is held constant. The simplest model to capture the above two basic response is two network theory composed of an elastic (backbone) network coupled with a viscoelastic transient network [1, 28]. Thus the total stress σ is the sum of the partial stresses σ_1 and σ_2 in each of the networks, i.e.,

$$\sigma = \sigma_1 + \sigma_2 \tag{0.4}$$

This theory will be used in this study to capture the mechanical response of the polymer which are subjected to impact.

F. Two dimensional viscoelastic model

The one dimensional model is discussed in [29]. Let us consider a plate that is infinite in z direction and has finite dimensions of length ' l ' in x direction and thickness ' h ' in y direction. From the use of implicit constitutive framework we assume that the response of material is nonlinear even though the strains are small. The cartesian coordinate system was used in this study. The stress tensor and velocity vector at any time ' t ' are represented by $\mathbf{T}(x,y,t)$, $\mathbf{v}(x,y,t)$ respectively.

The staggered grid in two dimension is shown in figure 6 along with a sample control volume where ' \mathbf{T} ' is the stress, ' u ' and ' v ' x and y component of velocity. From conservation of linear momentum we know that

$$\rho \frac{\partial \mathbf{v}}{\partial t} = \text{div} \mathbf{T} \quad (0.5)$$

The total stress on \mathbf{T} on the network is the sum of the partial stresses $\mathbf{T}^{(1)}$ and $\mathbf{T}^{(2)}$ in each networks, i.e.,

$$\mathbf{T} = \mathbf{T}^{(1)} + \mathbf{T}^{(2)} \quad (0.6)$$

The mechanical response of network 1 is given by

$$\frac{\partial \mathbf{T}^{(1)}}{\partial t} = \mathbf{C}_{ijkl} \frac{\partial \mathbf{v}_k}{\partial \mathbf{x}_l} \quad (0.7)$$

The mechanical response of network 2 is given by

$$\frac{\partial \mathbf{T}^{(2)}}{\partial t} = \mathbf{M}_{ijkl} \frac{\partial \mathbf{v}_k}{\partial \mathbf{x}_l} - \eta(\mathbf{T}^{(2)} \cdot \mathbf{T}^{(2)}) \mathbf{T}^{(2)} \quad (0.8)$$

where \mathbf{C}_{ijkl} and \mathbf{M}_{ijkl} are fourth order elasticity tensors.

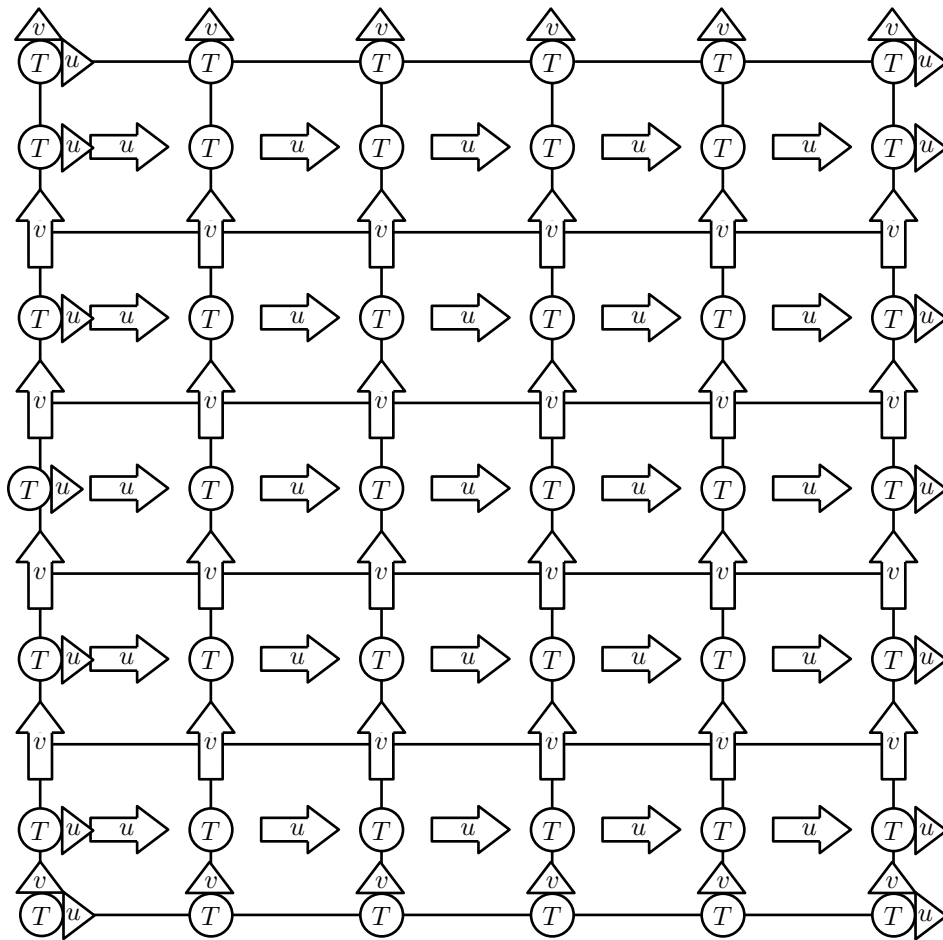

Fig. 6. Staggered grid in two dimension

G. Nondimensionalization

Before using the finite volume technique to solve the momentum and constitutive equations it is necessary to choose appropriate scales to nondimensionalize them. The main reason for the nondimensionalization is to reduce the number of independent parameters so that we could assess the factors influencing the solution. The non dimensionalized equations used here are

$$\begin{bmatrix} \frac{\partial T_{xx}^{(1)}}{\partial t} \\ \frac{\partial T_{yy}^{(1)}}{\partial t} \\ \frac{\partial T_{xy}^{(1)}}{\partial t} \end{bmatrix} = K_1 \begin{bmatrix} 1 - \nu & \nu & 0 \\ \nu & 1 - \nu & 0 \\ 0 & 0 & \frac{1-2\nu}{2} \end{bmatrix} \begin{bmatrix} \frac{\partial u}{\partial x} \\ \frac{\partial v}{\partial y} \\ \left(\frac{\partial u}{\partial y} + \frac{\partial v}{\partial x} \right) \end{bmatrix}$$

where $K_1 = \frac{E_1}{(1+\nu)(1-2\nu)}$

$$\begin{bmatrix} \frac{\partial T_{xx}^2}{\partial t} \\ \frac{\partial T_{yy}^2}{\partial t} \\ \frac{\partial T_{xy}^2}{\partial t} \end{bmatrix} = K_2 \begin{bmatrix} 1 & \nu & 0 \\ \nu & 1 & 0 \\ 0 & 0 & \frac{1-\nu}{2} \end{bmatrix} \begin{bmatrix} \frac{\partial u}{\partial x} \\ \frac{\partial v}{\partial y} \\ \frac{1}{2} \left(\frac{\partial u}{\partial y} + \frac{\partial v}{\partial x} \right) \end{bmatrix} - K_3 \begin{bmatrix} 1 - \nu & \nu & 0 \\ \nu & 1 - \nu & 0 \\ 0 & 0 & \frac{1-2\nu}{2} \end{bmatrix} \begin{bmatrix} T_{xx}^2 \\ T_{yy}^2 \\ T_{xy}^2 \end{bmatrix}$$

where $K_2 = \frac{E_2}{(1+\nu)(1-2\nu)}$ and $K_3 = \frac{E_2 \eta}{(1+\nu)(1-2\nu)} \left((T_{xx}^2)^2 + (T_{yy}^2)^2 + 2 * (T_{xy}^2)^2 \right)$

H. Solution Technique

The commonly used numerical techniques to solve the momentum equations are finite element and finite volume methods. Both involve the integration of the differential equations to obtain the weak form. The main advantage of FVM over FEM is conservation of quantities at each and every control volume. Integrating the x momentum equation over velocity control volume (see figure 7)

$$\int \frac{\partial u}{\partial t} dV^i = \int_w^e \frac{\partial T_{xx}}{\partial x} d\Omega^i + \int_S^N \frac{\partial T_{xy}}{\partial y} d\Omega^i \quad (0.9)$$

Now y momentum equation is integrated over velocity control volume

$$\int \frac{\partial v}{\partial t} dV^i = \int_W^E \frac{\partial T_{xy}}{\partial x} d\Omega^i + \int_s^n \frac{\partial T_{yy}}{\partial y} d\Omega^i \quad (0.10)$$

Similarly the constitutive equations are also integrated and the final discretised equations

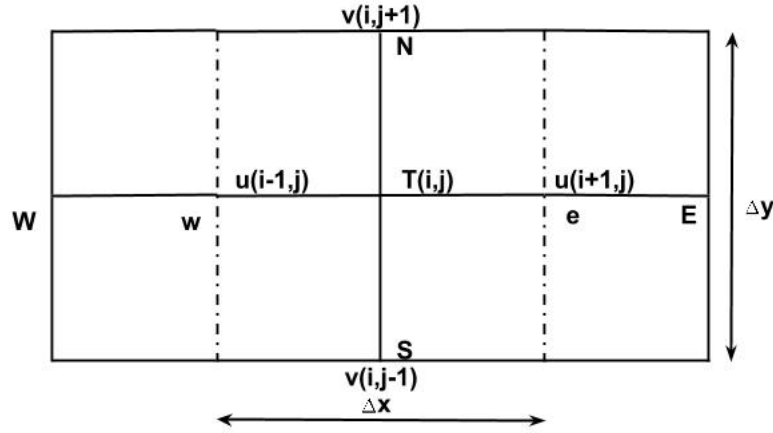

Fig. 7. Control Volume for the 2d

are

$$u^{k+1}(i, j) = u^k(i, j) + \frac{\Delta t}{\Delta x} (T_{xx}^k(i+1, j) - T_{xx}^k(i, j)) + \frac{\Delta t}{4\Delta y} (T_{xy}^k(i, j+1) + T_{xy}^k(i+1, j+1) - T_{xy}^k(i+1, j-1) - T_{xy}^k(i, j-1))$$

$$v^{k+1}(i, j) = v^k(i, j) + \frac{\Delta t}{4\Delta x} (T_{xy}^k(i+1, j) + T_{xy}^k(i+1, j+1) - T_{xy}^k(i-1, j) - T_{xy}^k(i-1, j+1)) + \frac{\Delta t}{\Delta y} (T_{yy}^k(i, j+1) - T_{yy}^k(i, j))$$

$$T_{xx}^{(1)k+1}(i, j) = T_{xx}^{(1)k}(i, j) + \alpha \Delta t \left(\left(\frac{u^k(i, j) - u^k(i-1, j)}{\Delta x} \right) + \nu \left(\frac{v^k(i, j) - v^k(i, j-1)}{\Delta y} \right) \right)$$

$$T_{yy}^{(1)k+1}(i, j) = T_{yy}^{(1)k}(i, j) + \alpha \Delta t \left(\nu \left(\frac{u^k(i, j) - u^k(i-1, j)}{\Delta x} \right) + \left(\frac{v^k(i, j) - v^k(i, j-1)}{\Delta y} \right) \right) \quad (0.11)$$

$$T_{xy}^{(1)k+1}(i, j) = T_{xy}^{(1)k}(i, j) + \alpha \Delta t \frac{1-\nu}{2} \left(\frac{1}{4\Delta y} (u^k(i-1, j+1) + u^k(i, j+1) - u^k(i-1, j-1) - u^k(i, j-1)) + (v^k(i+1, j) + v^k(i+1, j-1) - v^k(i-1, j-1) - v^k(i-1, j)) \frac{1}{4\Delta x} \right)$$

$$T_{xx}^{(2)k+1}(i, j) = T_{xx}^{(2)k}(i, j) + \beta \Delta t \left(\left(\frac{u^k(i, j) - u^k(i-1, j)}{\Delta x} \right) + \nu \left(\frac{v^k(i, j) - v^k(i, j-1)}{\Delta y} \right) \right) - \gamma \Delta t A(i, j) (T_{xx}^{(2)}(i, j) + \nu T_{xy}^{(2)}(i, j))$$

$$T_{yy}^{(2)k+1}(i, j) = T_{yy}^{(2)k}(i, j) + \beta \Delta t \left(\nu \left(\frac{u^k(i, j) - u^k(i-1, j)}{\Delta x} \right) + \left(\frac{v^k(i, j) - v^k(i, j-1)}{\Delta y} \right) \right) - \gamma \Delta t A(i, j) (\nu T_{xx}^{(2)}(i, j) + T_{xy}^{(2)}(i, j))$$

$$T_{xy}^{(2)k+1}(i, j) = T_{xy}^{(2)k}(i, j) + \beta \Delta t \frac{1-\nu}{2} \left(\frac{1}{4\Delta y} (u^k(i-1, j+1) + u^k(i, j+1) - u^k(i-1, j-1) - u^k(i, j-1)) + (v^k(i+1, j) + v^k(i+1, j-1) - v^k(i-1, j-1) - v^k(i-1, j)) \frac{1}{4\Delta x} \right) - \gamma \Delta t \frac{1-\nu}{2} T_{xy}^{(2)}(i, j) A(i, j)$$

I. Material parameters for the model

The material parameters were calculated using the experimental results obtained from the literature. PC and PU were considered for this study. PC creep compliance curves were obtained from [30]. PU creep compliance curve were obtained from [31]. Creep test data experiment for PC taken from literature was carried out at a constant pressure 46.3 MPa for a time period of 3600 s at room temperature. For PU, the experiments were performed at a constant pressure of 2.5 MPa for a time period of 560 s at a temperature of 30 C. The material parameters were calculated by minimizing the error between the experimental data and the model predicted data

using `fminsearch` function in MATLAB. The parameters obtained are shown in Table 1. The fit of experiment vs model for PC and PU are shown in Figure 8 and 9 respectively.

Table I. Material Parameters based on creep compliance data

	PC	PU
E_1	$1.7043 * 10^9 Pa$	$7.0658 * 10^7 Pa$
E_2	$3.8630 * 10^8 Pa$	$9.7342 * 10^7 Pa$
η	$6.4173 * 10^{-14}$	$6.4173 * 10^{-14}$

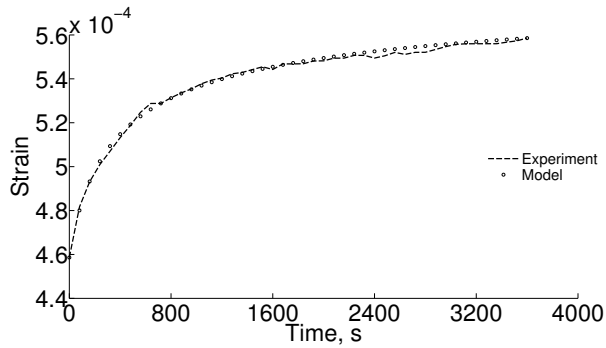

Fig. 8. Experiments on PC([30]) compared with the implicit model presented here. Notice the excellent match for the nonlinear creep compliance based on the constitutive parameters given in non-dimensionalized momentum equations.

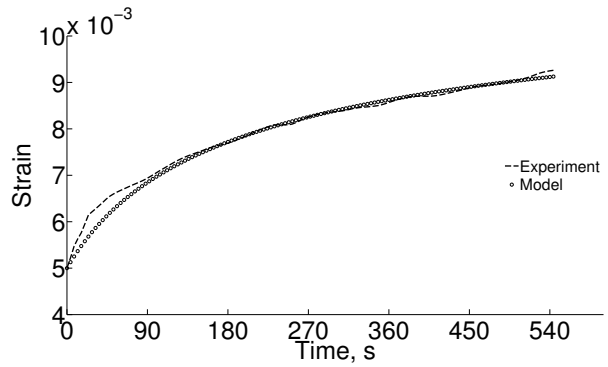

Fig. 9. Experiments on PU([32]) compared with the implicit model presented here. Notice the excellent match for the nonlinear creep compliance based on the constitutive parameters given in non-dimensionalized momentum equations.

J. Results and Discussion

In the study conducted, six different material combinations: (1) pure PC, (2) pure PU, (3) bilayer (PU/PC), (4) bilayer (PC/ PU), (5) trilayer (PC/PU/PC) and (6) trilayer (PU/PC/ PU) were considered. One face of the plate is fixed while the other face has a small regions which

is given a ramp stress in ' x ' direction with slope ' a ' for a time ' t_0 ' and is maintained constant till ' t '. All the remaining boundaries are stress free.

K. Wave Propagation

Sudden impact of a material results in the generation of waves. The speed at which these waves move depends upon the type of the material.

L. Stress Propagation

The propagation of stress at different instances of time is shown in Figures 10 through 15 through the thickness of the plate when impact is made on PC and PU. Initially the stresses are 0 throughout the thickness for all cases. The propagation is faster in PC layer when compared to that of PU since it is more compliant than PU. In case of the trilayer multiple reflections can be observed from the interfaces.

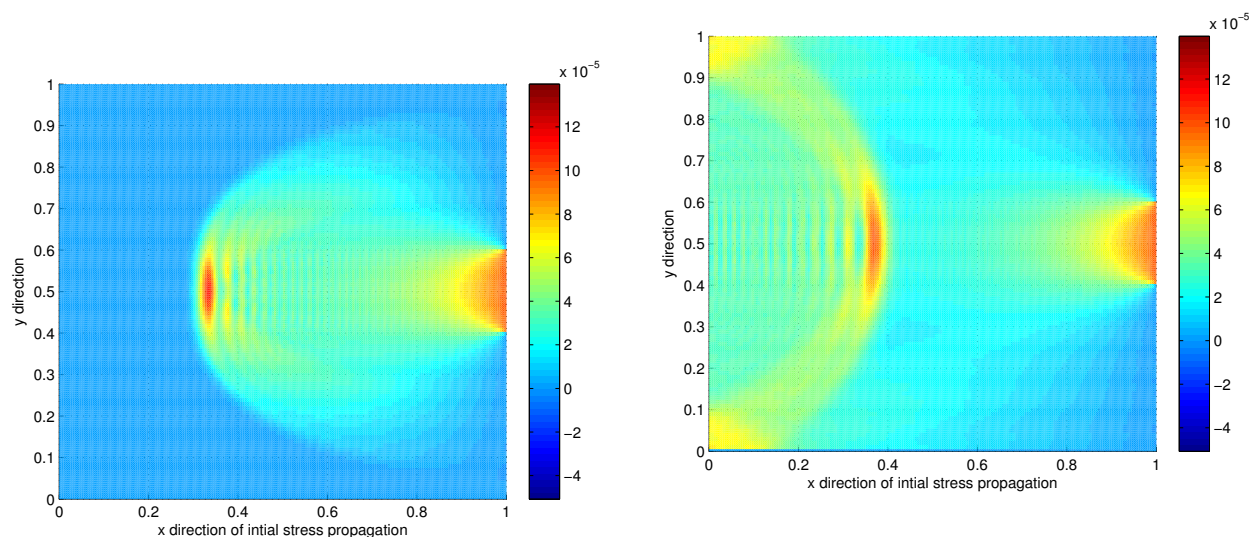

Fig. 10. Stress propagation at 20 units of time when PC is impacted. Transmission of stress through homogenous layer PC

Fig. 11. Stress propagation at 30 units of time when PC is impacted. Reflection and transmission of stress through homogenous layer PC

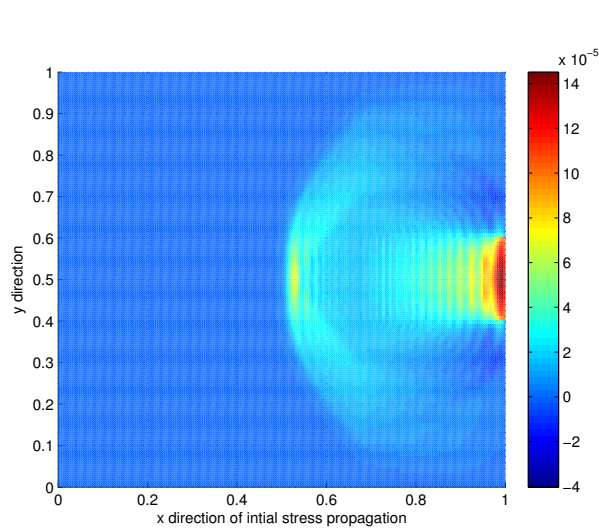

Fig. 12. Stress propagation at 20 units of time when PC is impacted. Transmission, reflection and refraction of stress through heterogenous layer PC/PU/PC

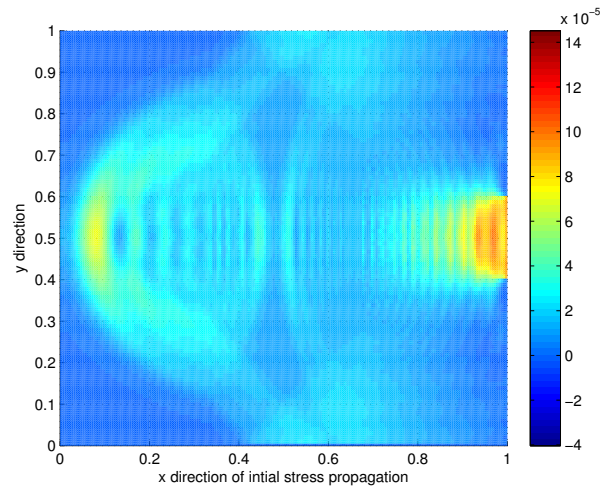

Fig. 13. Stress propagation at 30 units of time when PC is impacted. Multiple reflections refraction of stress from wall and interface through heterogenous layer PC/PU/PC

M. Stress and Kinetic energy on wall

The important application of interest with regard to the composite polymer that is used here is to reduce the impact on the wall besides which it is in contact. The peaks in Figure 16 and 17 represents the time when the impact wave reaches the wall. The damping effect on the wave can be seen from the gradual decrease in the peak response as the wave travels back and forth. The most important aspects that needs to be taken into account in the designing of polymer composites as shock absorbers is the magnitude of the stress and kinetic energy on the the wall. The above indicates that the magnitude of the stress and kinetic energys is lowest in case of the trilayer (PC/PU/PC) with regard to the six different layers that were considered.

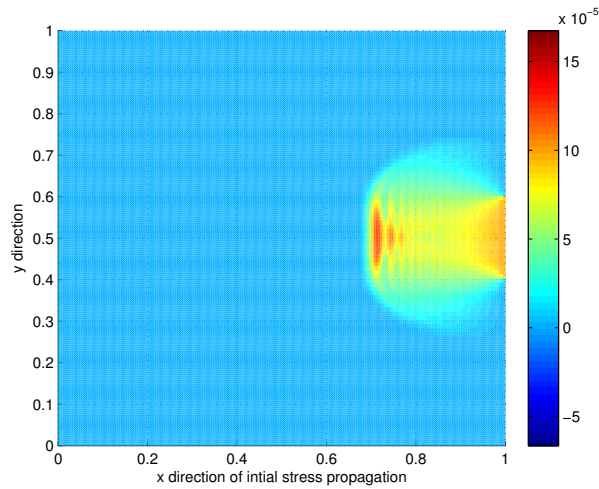

Fig. 14. Stress propagation at 20 units of time when PU is impacted. Transmission, reflection and refraction of stress through heterogenous layer PU/PC/PU

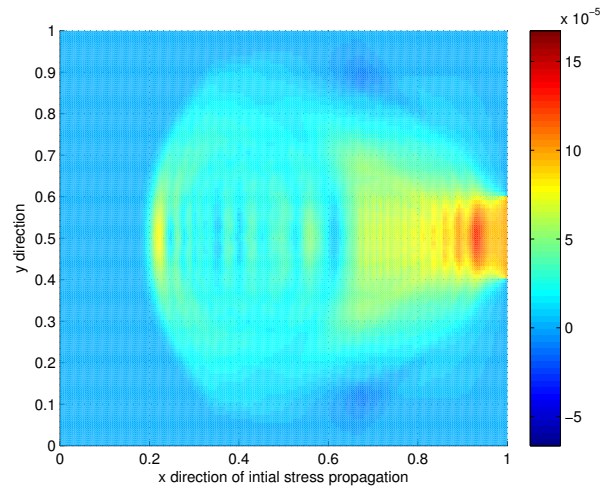

Fig. 15. Stress propagation at 30 units of time when PU is impacted. Transmission, reflection and refraction of stress through heterogenous layer PU/PC/PU

N. Conclusion

The performance of the different materials such as PC and PU under impact was studied using a nonlinear rate type model. The governing equations were solved numerically using a FVM approach. The parameters for characterizing the model were obtained from the creep compliance data found in the literature. The current one dimensional model discussed in the paper only allows for transmission and reflection of the waves. The one dimensional model discussed in the paper was able to capture the reflection phenomenon due to the interaction of the waves at the interface but fails to capture the dispersion phenomenon which the two dimensional model was able to capture. The comparison of the stress in the wall when using different combinations of PC and PU was carried out. The results show that the kinetic energy was lower on the wall when using a composite layer with the PC-PU-PC structure.

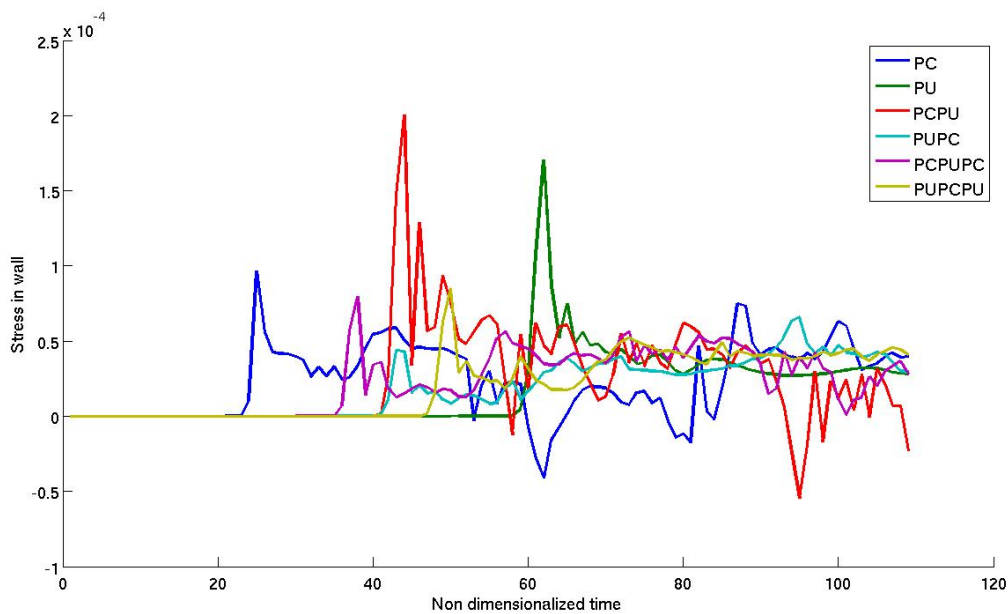

Fig. 16. Stress on wall for the different cases such as PU, PC, PU/PC, PC/PU, PC/PU/PC and PU/PC/PU

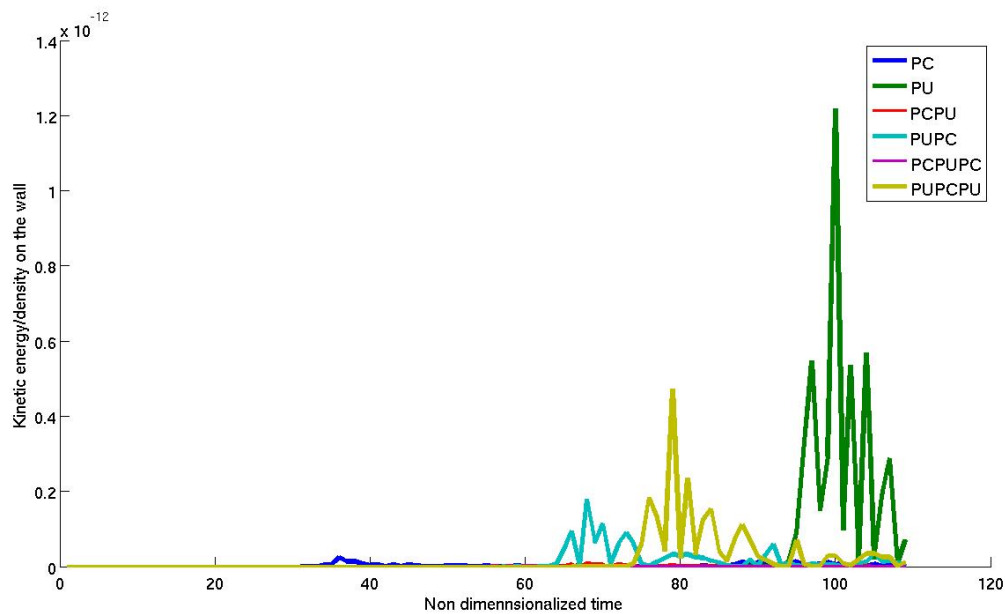

Fig. 17. Kinetic energy on wall for the different cases such as PU, PC, PU/PC, PC/PU, PC/PU/PC and PU/PC/PU

Bibliography

- [1] K. R. Rajagopal and A. R. Srinivasa. An implicit thermomechanical theory based on a gibbs potential formulation for describing the response of thermoviscoelastic solids. *International Journal of Engineering Science*, 70:15–28, 2013.
- [2] M. R. Amini, J. Simon, and S. Nemat-Nasser. Numerical modeling of effect of polyurea on response of steel plates to impulsive loads in direct pressure-pulse experiments. *Mechanics of Materials*, 42(6):615 – 627, 2010.
- [3] J Michael Boteler, A M Rajendran, and David Grove. Shock wave profiles in polymer matrix composite. *AIP Conference Proceedings*, 505(1):563–566, 2000.
- [4] Paul J. Hogg. Composites in armor. *Science*, 314(5802):1100–1101, 2006.
- [5] Srinivasan Arjun Tekalur, Arun Shukla, and Kunigal Shivakumar. Blast resistance of polyurea based layered composite materials. *Composite Structures*, 84(3):271 – 281, 2008.
- [6] J. Blair Perot. Discrete Conservation Properties of Unstructured Mesh Schemes. *Annual Review of Fluid Mechanics*, 43(1):299–318, January 2011.
- [7] I. Bijelonja, I. Demirdžić, and S. Muzaferija. A finite volume method for incompressible linear elasticity. *Computer Methods in Applied Mechanics and Engineering*, 195(44-47):6378–6390, September 2006.
- [8] Ž . Tuković, A. Ivanković, and A. Karać. Finite-volume stress analysis in multi-material linear elastic body. *International Journal for Numerical Methods in Engineering*, 93(4):400–419, 2013.

- [9] S. V. Patankar and D. B. Spalding. A calculation procedure for heat, mass and momentum transfer in three-dimensional parabolic flows. *International Journal of Heat and Mass Transfer*, 15:1787–1806, 1972.
- [10] M. A. Wheel. A finite-volume approach to the stress analysis of pressurized axisymmetric structures. *International Journal of Pressure Vessels and Piping*, 68(3):311–317, October 1996.
- [11] I. Demirdžić, E. Džaferović, and a. Ivanković. Finite-volume approach to thermoviscoelasticity. *Numerical Heat Transfer, Part B: Fundamentals*, 47(3):213–237, February 2005.
- [12] A. K. Slone, C. Bailey, and M. Cross. Dynamic solid mechanics using finite volume methods. *Applied Mathematical Modelling*, 27(2):69–87, February 2003.
- [13] A. S. Wineman and K. R. Rajagopal. *Mechanical response of polymers: an introduction*. Cambridge University Press, 2000.
- [14] Rami M. Haj-Ali and Anastasia H. Muliana. Numerical finite element formulation of the schapery non-linear viscoelastic material model. *International Journal for Numerical Methods in Engineering*, 59(1):25–45, 2004.
- [15] A. V. Amirkhizi, J. Isaacs, J. McGee, and S. Nemat-Nasser. An experimentally-based viscoelastic constitutive model for polyurea, including pressure and temperature effects. *Philosophical Magazine*, 86(36):5847–5866, 2006.
- [16] Tong Hui and Caglar Oskay. Computational modeling of polyurea-coated composites subjected to blast loads. *Journal of Composite Materials*, 46(18):2167–2178, 2012.
- [17] R. S. Rivlin and J. L. Ericksen. Stress deformation relation for isotropic material. *Journal of Rational Mechanics and Analysis*, 4:323–424–1806, 1955.

- [18] J. G. Oldroyd. On the formulation of rheological equations of state. *Proceedings of the Royal Society of London. Series A. Mathematical and Physical Sciences*, 200(1063):523–541, 1950.
- [19] E. H. Lee and I. Kanter. Wave propagation in finite rods of viscoelastic material. *Journal of applied physics*, 24:1115–1122, 1953.
- [20] P. S. Theocaris and N. Papadopoulou. Propagation of stress waves in viscoelastic media. *Polymer*, 19:215–219, 1978.
- [21] B Lundberg and R H Blanc. Determination of mechanical material properties from the two-point response of an impacted linearly viscoelastic rod specimen. *Journal of Sound and Vibration*, 126(1):97–108, 1988.
- [22] A B Musa. Predicting Wave Velocity and Stress of Impact of Elastic slug and Viscoelastic Rod Using Viscoelastic Discontinuity Analysis (Standard Linear Solid Model). In *Proceedings of the World Congress on Engineering*, volume 1, 2012.
- [23] Shiming Zhuang, Guruswami Ravichandran, and Dennis E Grady. An experimental investigation of shock wave propagation in periodically layered composites. *Journal of the Mechanics and Physics of Solids*, 51(2):245–265, 2003.
- [24] M. A. Zocher, S. E. Groves, and D. H. Allen. A three dimensional finite element formulation for thermoviscoelastic orthotropic media. *International journal for methods in engineering*, 40:2267–2288, 1997.
- [25] Zhao Han and Gary Gard. A three dimensional analytical solution of the longitudinal wave propagation in an infinite linear viscoelastic cylindrical bar. application to experimental techniques. *Journal of the Mechanics and Physics of Solids*, 43(8):1335 – 1348, 1995.

- [26] K. R. Rajagopal and A. R. Srinivasa. On the thermomechanics of materials that have multiple natural configurations Part I: Viscoelasticity and classical plasticity. *Zeitschrift für angewandte Mathematik und Physik ZAMP*, 55(5):861–893, 2004.
- [27] K. R. Rajagopal and A. R. Srinivasa. On the thermomechanics of materials that have multiple natural configurations: Part II: Twinning and solid to solid phase transformation. *Zeitschrift für angewandte Mathematik und Physik ZAMP*, 55(6):1074–1093, 2004.
- [28] K. R. Rajagopal and A. R. Srinivasa. A gibbs-potential-based formulation for obtaining the response functions for a class of viscoelastic materials. *Proceedings of the Royal Society A: Mathematical, Physical and Engineering Science*, 467(2125):39–58, 2011.
- [29] P. Alagappan, K.R. Rajagopal, and A.R. Srinivasa. Wave Propagation due to impact through layered polymer composites. *Composite Structures*, April 2014.
- [30] Said Jazouli, Wenbo Luo, Fabrice Bremand, and Toan Vu-Khanh. Nonlinear creep behavior of viscoelastic polycarbonate. *Journal of Materials Science*, 41(2):531–536, 2006.
- [31] Zhen Yao, Defeng Wu, Chong Chen, and Ming Zhang. Creep behavior of polyurethane nanocomposites with carbon nanotubes. *Composites Part A: Applied Science and Manufacturing*, 50:65–72, July 2013.
- [32] M. Worgull, M. Hecke, J. F. Htu, and K. K. Kabanemi. Modeling and optimization of the hot embossing process for micro- and nanocomponent fabrication. *Journal of Micro/Nanolithography, MEMS, and MOEMS*, 5(1):011005–011005–13, 2006.