

Thermoelectric Transfer Difference of Thermal Converters Measured with a Josephson Source

Charles J. Burroughs, Jr., Samuel P. Benz, Clark A. Hamilton, *Fellow, IEEE*, Todd E. Harvey, Joseph R. Kinard, *Senior Member, IEEE*, Thomas E. Lipe, *Member, IEEE*, and Hitoshi Sasaki

Abstract—We have measured the thermoelectric transfer difference of two thermal voltage converters using a Josephson source and compared the results to similar measurements made with a conventional semiconductor source. Both sources use the fast reversed dc method. The Josephson source is an array of 16 384 superconductor-normal-superconductor Josephson junctions that is rapidly switched between voltage states of +0.5, 0, and -0.5 V. A marginally significant difference is detected between measurements with the two different sources.

Index Terms—Digital-to-analog converter, Josephson array, metrology, standard, voltage.

I. INTRODUCTION

WE HAVE measured the thermoelectric transfer difference of both a single junction and a multijunction thermal voltage converter (TVC) using a programmable Josephson voltage source [1], [2] and compared the results to similar measurements using a conventional semiconductor source. Both sources utilize the fast reversed dc (FRDC) method [3]. The objective of these experiments was to confirm that two fundamentally different FRDC sources would produce comparable results when using the same thermal voltage converters.

The FRDC measurement technique compares the response of the TVC to the three different waveforms shown in Fig. 1. Each waveform is derived by switching between stable dc levels. For the waveform labeled "FRDC Mode," the voltage is alternately reversed in polarity. The dc waveforms have a constant output level except for brief transitions to zero that duplicate the transient portions of the FRDC waveform. The Josephson source eliminates uncertainties related to the fluctuations in the output voltage level and offsets induced by the switches.

Fig. 2 is a block diagram of the measurement system that uses the Josephson array. To synthesize the FRDC waveform, the computer loads the waveform memory with the required state (-1, 0, +1) of the array for up to 65 536 time steps of the specified waveform. When the waveform clock is started, the memory steps through the time sequence, and its outputs drive



Fig. 1. FRDC waveforms.

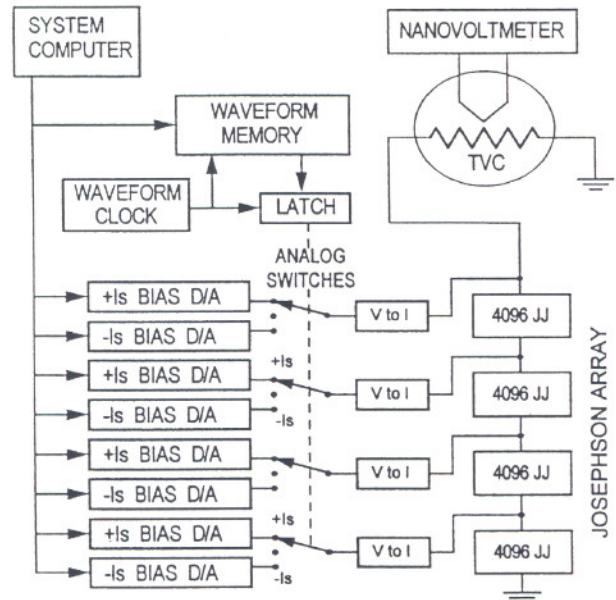

Fig. 2. Block diagram of the Josephson array system.

the analog switches that select the bias appropriate to the -1, 0, or +1 constant voltage steps for each array segment. The outputs of the analog switches control fast, constant-current drivers for the array bias lines. A latch on the digital inputs to the analog switches ensures that all switches change state within a few nanoseconds. The settling time of the bias current drivers is 400 ns.

At this bandwidth (approximately 1 MHz), the bias source generates transients that have a significant probability of trapping magnetic flux in the Josephson array. To avoid this problem, we used only those array segments with the largest resistance to flux trapping. As a result we were able to use only half of the 32 768 Josephson junctions (JJ), resulting in a maximum output voltage of 0.5 V.

Manuscript received July 2, 1998. This work was supported by the U.S. Army under CCG Project 346.

C. J. Burroughs, Jr., S. P. Benz, C. A. Hamilton, and T. E. Harvey are with the National Institute of Standards and Technology, Boulder, CO 80303, USA (e-mail: burroughs@boulder.nist.gov).

J. R. Kinard and T. E. Lipe are with the National Institute of Standards and Technology, Gaithersburg, MD 20899 USA.

H. Sasaki is with the Electrotechnical Laboratory, Tsukuba 305-0045, Japan. Publisher Item Identifier S 0018-9456(99)03227-1.

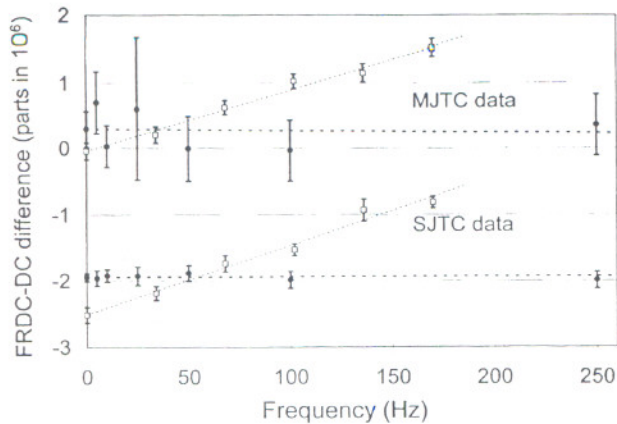

Fig. 3. FRDC measurement results. The upper pair of least-sum-squares (LSS) fit lines correspond to the MJTC. The lower pair of LSS fit lines are for the SJTC. Data from the Josephson source is shown with open squares, and data from the semiconductor source is shown with solid circles. The uncertainty shown is Type A, $k = 2$.

TABLE I
COMPARISON OF FRDC-DC DIFFERENCES

	Multi Junction TVC	Single Junction TVC
Josephson Source	$-0.05 \pm 0.13 \times 10^{-6}$	$-2.51 \pm 0.12 \times 10^{-6}$
Semiconductor Source	$+0.29 \pm 0.27 \times 10^{-6}$	$-1.94 \pm 0.06 \times 10^{-6}$

II. MEASUREMENTS

FRDC-DC difference measurements were made by recording the TVC output for a sequence of inputs: FRDC, DC⁺, DC⁻, FRDC, and computing the difference between the means of the two FRDC and two dc measurements. Fig. 3 shows the FRDC-DC difference as a function of frequency for a single junction thermal converter (SJTC), and a multijunction thermal converter (MJTC). Each was measured at 0.5 V with both the Josephson and semiconductor sources. Each point represents the average of many difference measurements. The total measurement time for each thermal converter was about eight hours.

The Josephson source has the advantage that its output is intrinsically stable, and the positive and negative voltages are perfectly matched. However, a mismatch in the Josephson array switching transients when the waveforms in Fig. 1 are generated gives rise to a frequency dependent component in the curves of Fig. 3. This component of the FRDC-DC difference can be uniquely identified because it has a linear frequency dependence [3], which results in a slope of the least-sum-squares (LSS) fit line. Thus, the thermoelectric transfer difference is given by the extrapolation of the curves to zero frequency. In the case of the semiconductor FRDC source, the switching transients have been very carefully matched so that there is essentially no frequency dependence. Table I lists the measured FRDC-DC differences based on the extrapolation of the curves of Fig. 3 to zero frequency. The Type A standard uncertainties use a coverage factor $k = 2$ and are based on the standard formula for the extrapolation of a LSS fit line* [4].

TABLE II
AC-DC DIFFERENCES IN THE AUDIO FREQUENCY RANGE

Frequency	Multi Junction TVC	Single Junction TVC
30 Hz	$-0.1 \pm 0.5 \times 10^{-6}$	$-1.7 \pm 0.7 \times 10^{-6}$
100 Hz	$+0.1 \pm 0.5 \times 10^{-6}$	$-1.8 \pm 0.9 \times 10^{-6}$
1 000 Hz	$+0.2 \pm 0.5 \times 10^{-6}$	$-1.7 \pm 0.7 \times 10^{-6}$
10 000 Hz	$+0.1 \pm 0.5 \times 10^{-6}$	$-1.9 \pm 1.1 \times 10^{-6}$

The Type A standard uncertainties of the FRDC-DC measurements for the Josephson and semiconductor source are comparable. There is, however, a marginally significant difference between the measured FRDC-DC differences of the two sources. This suggests the existence of Type B standard uncertainties in either or both of the sources, not an unexpected result.

III. DISCUSSION

In the measurements presented so far, the property of the thermal converters that we measured with the FRDC sources was the thermoelectric transfer difference, i.e., the FRDC-DC transfer difference due to thermoelectric effects. Next, we measured the conventional ac-dc differences of the same thermal converters in terms of the NIST reference and primary standards using sinusoidal waveforms. These data are presented in Table II, and were measured with an input amplitude of 0.5 V (the same amplitude used in the FRDC measurements.) The uncertainties shown are the combined standard uncertainties ($k = 1$), which include both Type A and Type B components.

Since the thermoelectric transfer difference is a dc quantity, that component of the ac-dc difference should be the same for rectangular waveforms (FRDC-DC method) and sinusoidal waveforms (ac-dc method), and we can compare the results obtained with the two techniques. In the audio frequency range, a well constructed MJTC would be expected to exhibit small thermoelectric transfer differences and small ac-dc differences, just as the two sets of MJTC data show. A single junction thermoelement might be expected to have thermoelectric transfer differences of a few parts in 10^6 , and yet have comparably small ac-dc differences. The SJTC results are consistent with these expectations as well.

IV. CONCLUSION

When the data shown for these thermal converters is considered all together, it suggests that in the audio frequency range the ac-dc differences are primarily due to thermoelectric effects, as anticipated. Furthermore, there appear to be no statistically significant differences between the overall FRDC-DC results and the ac-dc difference measurements.

The level of agreement between the Josephson and semiconductor FRDC sources provides evidence that the Type B standard uncertainty in both of these methods is less than 1 part in 10^6 . Furthermore, both of the FRDC sources agree well with the ac-dc differences measured using the NIST reference and primary standards. Considering that the combined uncertainties are on the order of (0.5 to 1) part in 10^6 , the results show no

statistically significant differences between the FRDC thermoelectric transfer difference measurements and the conventional ac-dc difference measurements.

Based on these experiments, we believe that the flux trapping problem that limited the Josephson array output to 0.5 V can be solved with a bias system that uses low impedance (constant voltage) bias drivers. Repeating the experiment at 1 V will give a factor-of-four increase in the TVC output and a consequent reduction in the uncertainty of the FRDC-DC measurement.

It is a well accepted hypothesis that the frequency-independent part of the ac-dc difference in TVC's (including measurement with the FRDC method) is the result of thermal effects and thermoelectric voltages in the dc mode. To verify this hypothesis and identify other contributions to ac-dc difference, it is necessary to realize a sinusoidal waveform that is directly derived from the Josephson effect. Efforts are under way to create such an ac standard using a pulse driven Josephson array [5] and a rapid-single-flux-quantum digital-to-analog converter.

ACKNOWLEDGMENT

The authors would like to thank K. Takahashi, JEMIC, Japan, for his valuable contribution in the development of the semiconductor FRDC source.

REFERENCES

- [1] C. A. Hamilton, C. J. Burroughs, S. P. Benz, and J. R. Kinard, "AC Josephson voltage standard: Progress report," *IEEE Trans. Instrum. Meas.*, vol. 46, pp. 224-227, Apr. 1997.
- [2] S. P. Benz, C. A. Hamilton, C. J. Burroughs, T. E. Harvey, and L. A. Christian, "Stable 1-Volt programmable voltage standard," *Appl. Phys. Lett.*, vol. 71, no. 13, pp. 1866-1868, Sept. 1997.
- [3] M. Klonz, G. Hammond, B. D. Inglis, H. Sasaki, T. Spiegel, B. Stojanovic, K. Takahashi, and R. Zirpel, "Measuring thermoelectric effects in thermal converters with a fast reversed dc," *IEEE Trans. Instrum. Meas.*, vol. 44, pp. 379-382, 1995.
- [4] N. Draper and H. Smith, *Applied Regression Analysis*, 2nd ed. New York: Wiley, 1981, pp. 82, 83.
- [5] S. P. Benz, C. A. Hamilton, C. J. Burroughs, and T. E. Harvey, "AC and dc bipolar voltage source using quantized pulses," this issue, pp. 266-269.

Charles J. Burroughs, Jr., for a photograph and biography, see this issue, p. 269.

Samuel P. Benz, for a photograph and biography, see this issue, p. 269.

Clark A. Hamilton (S'64-M'71-F'95), for a photograph and biography, see this issue, p. 269.

Todd E. Harvey, for photograph and biography, see this issue, p. 269.



Joseph R. Kinard (S'69-M'71-SM'80) was born in West Palm Beach, FL. He received the B.A. degree in physics from Florida State University, Tallahassee, and the M.S. degree in physics from the University of Massachusetts, Amherst.

From 1963 to 1968, he was with the Electricity Division of the National Bureau of Standards. From 1968 to 1971, he was with the Department of Physics, University of Massachusetts, Amherst. From 1971 to 1983, he was active in a wide range of electrical measurements at the School of Electrical Engineering, University of New South Wales, Kensington, Australia. He returned to the Electricity Division at the National Institute of Standards and Technology, Gaithersburg, MD, in 1983, where he works in the area of thermal transfer standards, including the application of new technologies to improved primary and working-standard thermal converters.

Mr. Kinard's work has been recognized with two U.S. Department of Commerce Silver Medals and the R&D 100 Award.



Thomas E. Lipe (M'94) was born in Albemarle, NC, in 1958. He received the B.S. degree in physics from East Carolina University, Greenville, NC, in 1980 and the M.S. degree in physics from The Catholic University of America, Washington, DC, in 1994.

He joined the Electricity Division, National Institute of Standards and Technology, Gaithersburg, MD, in 1983, where he was responsible for automating the ac-dc difference calibration systems. His current research interests are in ac-dc difference

measurements, ac voltage measurements using cryogenic techniques, and the design and fabrication of advanced thermal converters.

Hitoshi Sasaki, photograph and biography not available at the time of publication.