

Three-dimensional computer model of the human buttocks, in vivo

Beth A. Todd, PhD and John G. Thacker, PhD

University of Alabama, Tuscaloosa, AL 35487-0278; University of Virginia, Charlottesville, VA 22903

Abstract—In an effort to reduce the incidence of decubitus ulcers among wheelchair users, current work in cushion design concentrates on minimizing the pressure at the buttock-cushion interface. Finite element analysis can show the stress levels throughout the soft tissue between the cushion and the ischial tuberosity and give designers a better indication of the effects of a particular cushion. Finite element models were generated of the tissues around the ischial tuberosities of male and female subjects. Linear three-dimensional models were generated using a 386 computer and solved with infinitesimal deflection theory. The resulting minimal principal stresses were 17 kPa and 15 kPa at the buttock-cushion interface for seated male and female subjects, respectively. Computational results were verified experimentally with magnetic resonance imaging and interface pressure measurements.

Key words: *biomechanics, computer models, decubitus ulcer, feasibility studies, magnetic resonance imaging, mechanical stress, pressure, wheelchairs.*

INTRODUCTION

Development of decubitus ulcers is a serious problem for wheelchair users, who sometimes sit in their chairs from 12 to 16 hours per day. For those with insensate skin, such as some individuals with paraplegia and quadriplegia, the first indication of ulcer formation is redness on the skin surface. However, surgeons have found evidence that ulcers

form internally and spread toward the surface of the skin (1). By the time surface damage is noticed, subcutaneous necrosis may already have occurred.

Producers of wheelchair cushions use interface pressures between the buttocks and the cushion to assist in determining if adequate pressure relief is provided. If interface pressure is directly proportional to the internal pressure at the site of decubiti formation, pressure at the interface will provide enough information for cushion design. If the two pressures are not directly proportional, more information must be gathered to effectively design pressure relieving cushions.

Previous work has been performed by several investigators in this area. Reddy, et al., created an experimental buttock model from a semicircular slab of PVC gel (13.9 cm in diameter and 3.8 cm thick). The gel was placed around a 5.7 cm-long wooden core that represented the ischial tuberosity. The purpose of their experiments was to investigate the stress distribution in the buttock resulting from several common cushion materials. Four different foam cushions and a PVC gel cushion, each 38 mm thick, were investigated under a vertical load of 20.2 N applied to the buttock. In general, high stress regions occurred beneath the wooden core. The lowest normal stresses were caused by the medium density foam cushion. The shear stresses generated by the gel cushion were approximately twice those from the medium density foam cushion (2).

Brunski, et al. generated pressure sores in Yorkshire pigs using cylindrical indenters with surface radii of curvature of 8 cm and 3 cm. The

Address all correspondence and requests for reprints to: Beth A. Todd, PhD, The University of Alabama, 210 Hardaway Hall, Box 870278, Tuscaloosa, AL 35487-0278.

affected tissues were modeled with axisymmetric finite elements to calculate the stress distributions around the indenters. In the model, the tissue was assumed to be linear, elastic, and isotropic. Results showed an approximately Hertzian surface stress profile for the 3 cm radius of curvature indenter. The other indenter created a non-Hertzian profile with large peaks near the contact radius. Maximum octahedral stresses occurred in the skin layer (3).

Chow and Odell created an axisymmetric, three-dimensional finite element model of a human buttock. The purpose of their work was to determine the three-dimensional stress state within the soft tissues due to different loading conditions. A buttock was modeled as a homogeneous hemisphere of linear elastic isotropic soft tissue with a rigid core to represent the ischial tuberosity. It was assumed that each buttock bore a load of 300 N. The six loading conditions considered were floating on water, floating on mercury, sitting on a rigid frictionless flat surface, applying a modified cosine pressure distribution, sitting on a foam cushion, and sitting on a foam cushion with a lubricated interface. In all cases, the highest stresses occurred under the rigid core. Results showed that hydrostatic pressure produced minimal distortion and that gradient pressure was the main cause of von Mises stress (4).

Kett and Levine developed a model based on the premise that pressure sore etiology could be better related to tissue distortion or deflection than seating interface pressure. The bond-graph technique was used to analyze their one-dimensional nonlinear mechanical model. The authors felt that their model provided insight into the significance of time dependence in the formation of decubitus ulcers (5).

The purpose of the research presented in this paper is 1) to show that a finite element model could be developed that gave results consistent with experimental data and 2) to begin to relate buttock/cushion interface pressures to internal pressures at the ischium. The finite element method can be used to calculate relationships between displacements and pressures or stresses for complex structures made from several materials. Thus, it can be used to examine different designs or prototypes of a device, such as a wheelchair cushion (6).

Wheelchair cushion design is usually performed in small business or clinical settings that do not have access to CRAY or large mainframe computers.

Particularly in light of the need to design and generate devices at minimal costs, it was decided to generate the models in this project using IBM-compatible 386 and 486 computers. The finite element package PRIMEGEN™ was donated by Geometrics, Inc. and used to generate and solve the models.

METHOD

Models were generated of two ambulatory subjects: a 58-kg female and a 74-kg male. Models were created to represent seated and supine positions for each subject on a custom-contoured cushion. To generate the models, their geometries were defined, material properties determined, and loading and boundary conditions prescribed.

The objectives of this project were to show that the finite element method can be used in cushion design and to compare stresses throughout the soft tissue. To participate in this project, the experimental subjects had to undergo several different experiments. Once the techniques for generating a model have been developed, members of specific populations may be recruited to determine the characteristics of a particular group. For establishing the initial protocols, young ambulatory subjects were chosen for their availability and agility.

Geometry

A number of assumptions regarding all aspects of the model were made to keep the size of the model manageable for a desktop computer. The ischium is cited as the location where wheelchair users are most likely to develop pressure sores (7). Bilateral symmetry was assumed, so only the tissues around the right ischial tuberosity were included in the model.

The geometry of each subject's anatomy was generated noninvasively using nuclear magnetic resonance imaging (MRI) (8). Each subject was placed in a supine position inside the tube of a Siemens Magnetom 1.0 Tesla whole-body MRI imager. The imager measured the hydrogen content of different tissues of each body and generated a two-dimensional map with a 1 mm resolution of the geometry of transverse abdominal slices. A typical slice of a transverse abdominal cross-section is shown in **Figure 1**. Information from each slice was digitized and

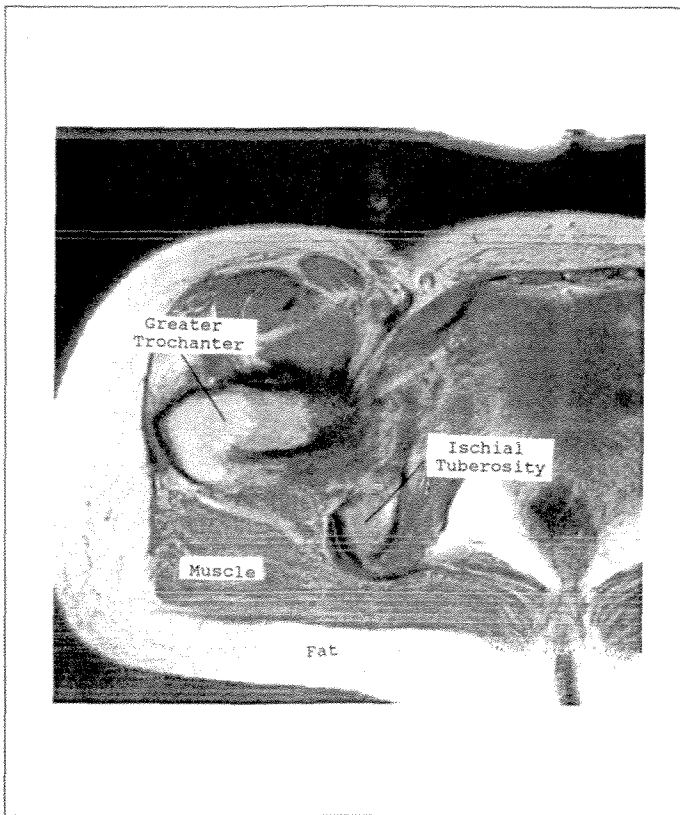

Figure 1.
Typical MRI image of a transverse cross-section of the pelvis.

used as the basis for generating the finite element geometry. By combining the information from several parallel slices spaced 8 mm apart, a three-dimensional model was created.

A cross-section of the finite element model is shown in **Figure 2**. The half-cushion shown is 221 mm wide and 73.6 mm deep. For the male subject, the ischial tuberosity is located 64.4 mm from the plane of bilateral symmetry, 109 mm above the buttock-cushion interface, and 94 mm from the lateral surface. For the female subject, these distances are 60.8 mm, 111 mm, and 97 mm, respectively. Both models were generated with eight-noded three-dimensional isoparametric brick elements. The male model contains 1008 elements: ischial tuberosity 36, cushion 433, elastic foundation 84, and soft tissue 455. The female model contains 1008 elements: ischial tuberosity 120, cushion 337, elastic foundation 83, and soft tissue 468.

The geometries for the models were generated by placing the subjects in "free-hanging" positions. The back and thighs of each subject were elevated

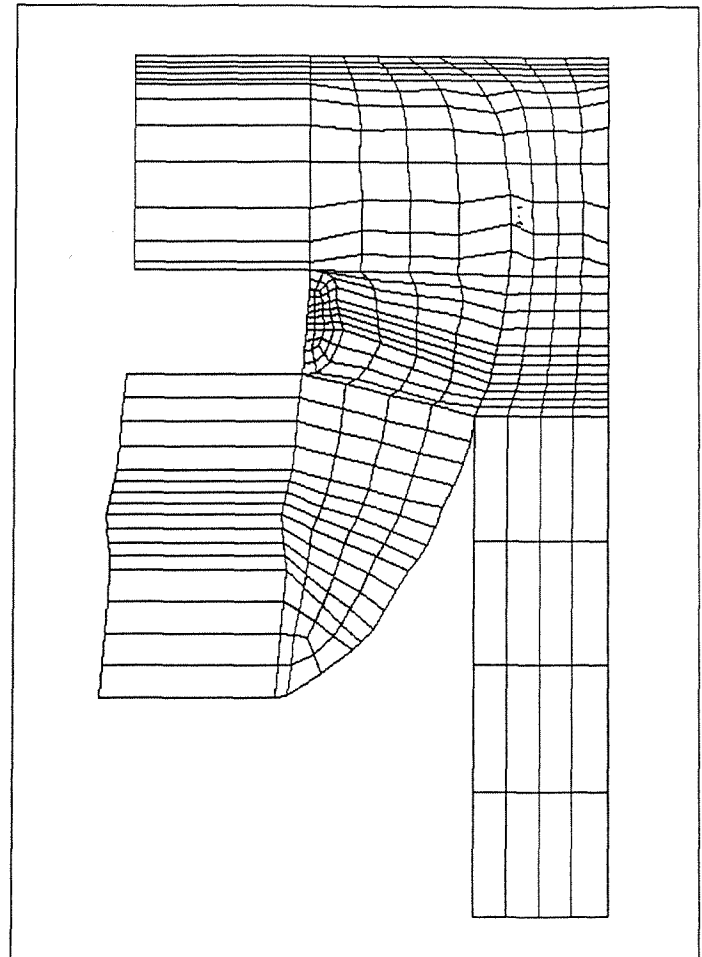

Figure 2.
Cross-section of finite element model of male subject.

and supported by foam cushions while the buttocks tissues were maintained in their undeformed shape. For model verification purposes, both subjects were reimaged while reclined on custom-contoured cushions with their tissues under body weight loading. Both of these positions are presented pictorially in **Figure 3**.

The tube in the MRI imager has an opening slightly larger than the average adult's shoulder width. This small diameter precluded the generation of geometry for the subjects in a seated position. The supine geometry was used in both cases, and the material properties were adjusted to account for the postural change. The change in orientation of the muscles in the supine position led to the overall trend of the tissues around the ischial tuberosity being less stiff or having a smaller Young's modulus, as shown in **Table 1**.

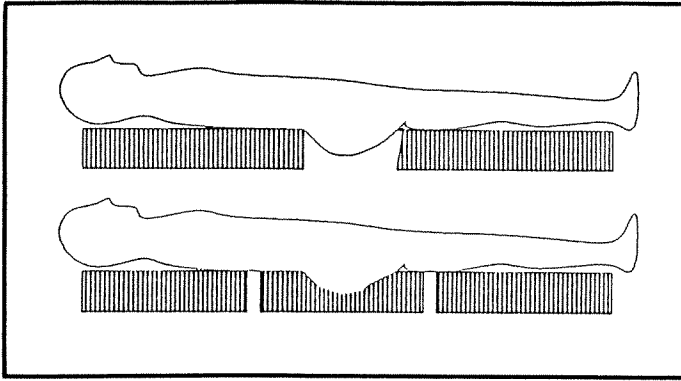

Figure 3.
The loading conditions used for imaging.

Table 1.
Material properties used in models.

Material	Young's Modulus E (kPa)	Poisson's Ratio ν
Bone	17000	0.31
Cushion	10.2	0.1
Soft Tissue Seated Female	47.5	0.49
Soft Tissue Supine Female	11.9	0.49
Soft Tissue Seated Male	64.8	0.49
Soft Tissue Supine Male	15.2	0.49
Elastic Foundation Supine Female	1.19	0.49
Elastic Foundation Supine Male	25.3	0.49

As a person sits down, the contact area between the buttocks and the seating surface changes. To model this situation, many cushion geometries would require the use of sophisticated contact-gap elements to allow change in contact surface between loaded and unloaded conditions. The use of a custom-contoured cushion prevented the introduction of that additional complication into the model. Common nodes were used between the elements representing the buttocks and those representing the cushion.

Material Properties

Four different materials were included in each model: bone, soft tissue, cushion, and elastic foun-

ation. Average values of Young's modulus of elasticity and Poisson's ratio for bone were taken from the literature (9-17). Material properties of the cushion material were determined from load-deflection tests described in the literature (7).

Material properties for each subject in both seated and supine positions were determined experimentally by a process similar to that described by Steege, Schnur, and Childress (18). A custom-contoured cushion made from uncoated, open cell, HR 55 polyurethane foam was cut for each subject in both seated and supine positions. A hole was cut in each cushion under the subject's right ischial tuberosity, and the cushion was placed on a wooden chair especially designed for measuring these material properties. The contour gage developed by Gordon was used to record the data (19,20). The gage consisted of a stepper motor that drove a threaded shaft containing a strain gage to measure axial compression. As the motor drove the shaft upward in one mm increments, the axial force was recorded until a predetermined force was measured or exceeded. A Keithley data acquisition system was used to record the relationship between the position of the shaft and the force on the gage. These data were transformed into a force deflection curve as shown in **Figure 4**. The equation associated with the curve in **Figure 4** is

$$F = -0.112 + 0.967x + 10^{(-0.908 + 0.0704x)}$$

To maintain the manageability of the model, several assumptions were made regarding the mate-

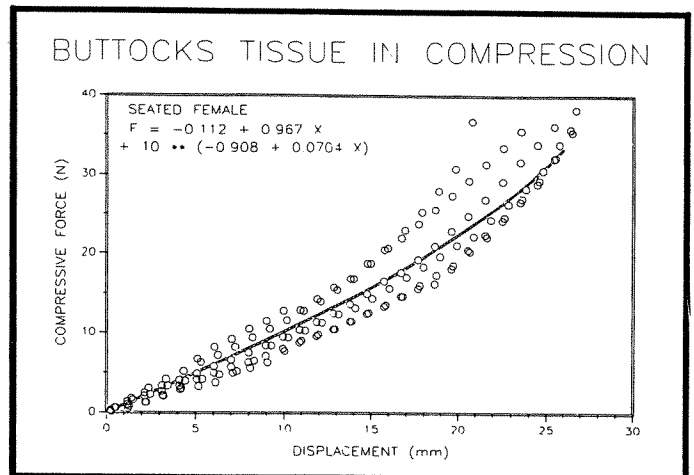

Figure 4.
Force-displacement relationship for female subject in seated position.

rial properties of the soft tissue. While biological tissue is nonlinear, anisotropic, and viscoelastic, due to the lack of knowledge of the particular microstructure of the tissue, it was assumed that the soft tissue in the buttocks was linear, isotropic, and time independent. Therefore, the initial linear portion of the force-deflection curves was used to calculate four moduli of elasticity, one for each subject in each position. Material properties used in the models are shown in **Table 1**.

Applied Loading

Many investigators have pondered the transfer of load through the tissues of the body (21,22). Most of the load is carried through the skeletal structure, but it is not clear how it is transferred through the soft tissue of the buttocks when someone sits. To maintain a manageable model, a simple form of loading was applied. A single concentrated force was applied downward at a node in the center of the top surface of the elements representing the ischial tuberosity. This type of load application creates a region of stress concentration in the ischial tuberosity. Since the region of interest is the soft tissue between the cushion and the bottom of the ischial tuberosity, this region of fictitious high stress can be ignored.

The magnitude of the force applied to each model was based on each subject's weight. For the supine position, half of the weight of the pelvis was used. For an average male, this is 6.7 percent of the total body weight or 48.4 N for the 74 kg subject (23). For an average female, the right pelvis comprises 8.6 percent of the total body weight or 48.5 N for the 58 kg subject.

For the seated position, half of the weight of the upper body was used. For an average male, this is 29.2 percent of the total body weight or 211 N for the 74 kg subject. For an average female, the right half of the upper body contains 29.7 percent of the total body weight or 167.5 N for the 58 kg subject.

Boundary Conditions

Bilateral symmetry was assumed so that only a portion of the right buttock was included in the model. To represent this symmetry, all of the nodes on the plane of symmetry or centerline boundary were constrained from horizontal motion.

In normal use, a wheelchair cushion is placed on top of a hard, flat surface. To represent that

surface, all of the nodes on the bottom plane of the cushion were constrained from vertical motion.

The other planes of the model represent surfaces that have been cut from other tissues of the body. These surfaces cannot be accurately represented by either free or fixed surfaces. In a compromise between accuracy and model size, the top plane of the model was constrained by an elastic foundation. The front and back surfaces of the model remained free. The elastic foundation was modeled by a series of semi-infinite elements constrained on the end that is not attached to the soft tissue. Material properties for the elastic foundation are given in **Table 1**.

RESULTS

Displacements were calculated with the program PRIMEGEN™ for each subject under body weight loading in both the seated and supine positions. A graphical representation of the vertical displacements for the seated male subject are shown in **Figure 5**. Note that the figures containing displacement and contour plots are black and white sketches of the color computer plots. The outline of the elements may not exactly match that shown in **Figure 2**. A vectorial sum of the y- and z-displacements (downward and forward) for the seated male subject are shown in **Figure 6**. In all cases, the ischial tuberosity had translated as the soft tissue under it was compressed and pushed outward. As expected, the models of the seated position showed more deflection (y- and z-directions) than the models of the supine position. Deflection of the soft

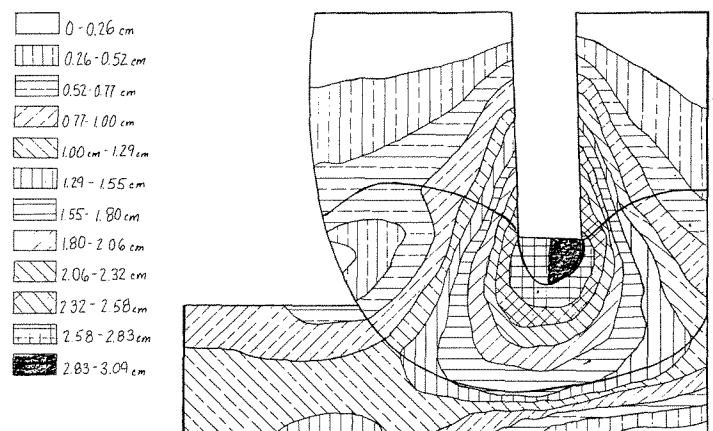

Figure 5. Vertical displacements for seated male subject.

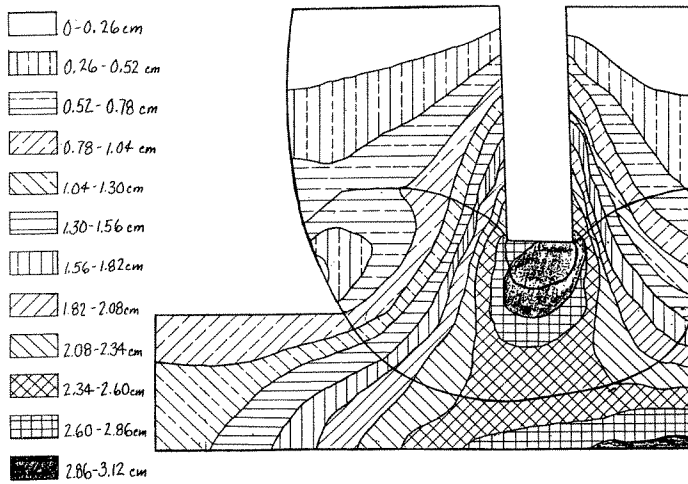

Figure 6.
y- and z-displacements for seated male subject.

tissue directly under the ischial tuberosity was calculated. Comparisons of the computational deflections with those determined from the digitized images generated with the MRI are shown in **Table 2**.

For both the male and female subjects, the computational displacements are within 5 percent of the displacements that could be measured experimentally with the MRI. The displacements in **Table 2** are vertical displacements. Note that the female subject shows greater vertical displacement in the supine position than in the seated position. In the seated position, the z-displacement is much greater (approximately 6 cm) than it was in the supine position. This large displacement is partly due to the fact that the front and back surfaces of the model are free.

The computer program PRIMEGEN™ is capable of calculating stresses in the directions of the x, y, and z axes, the three principal stresses, and von Mises stress. The stresses of primary interest were

Table 2.
Displacements under the right ischial tuberosity.

Position	Computational Displacement (cm)	Experimental Displacement (cm)
Male—supine	1.8	1.7
Male—seated	3.34	Not available
Female—supine	3.81	3.9
Female—seated	3.00	Not available

the minimum principal stresses, σ_3 , which are analogous to the pressures which are often measured clinically. Von Mises stresses were also calculated. An example of the stress contour plots for the seated male subject are shown in **Figures 7 and 8**. These plots show there is little difference in the buttock-cushion interface stresses between the seated and supine positions for both subjects. The values in these plots are somewhat misleading because the stresses are in units of N/cm^2 . One N/cm^2 is approximately equivalent to 75 mm of Hg which are the units normally used in clinical studies. In those studies, changes in pressure of 25 to 40 mm of Hg

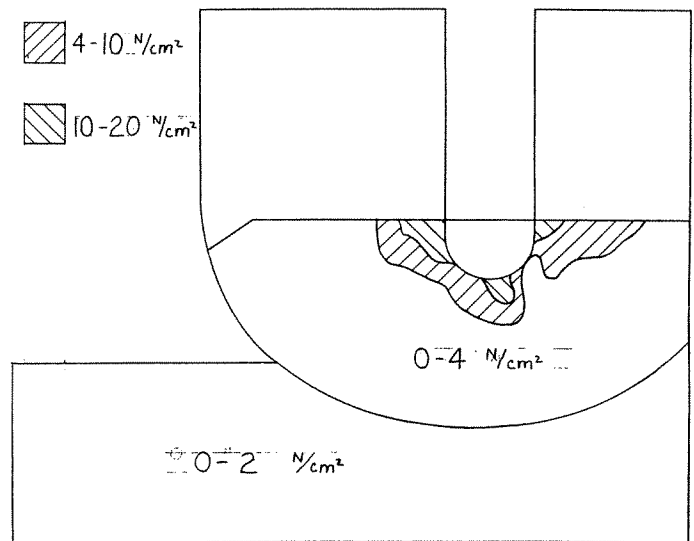

Figure 7.
Minimum principal stresses for male subject in seated position.

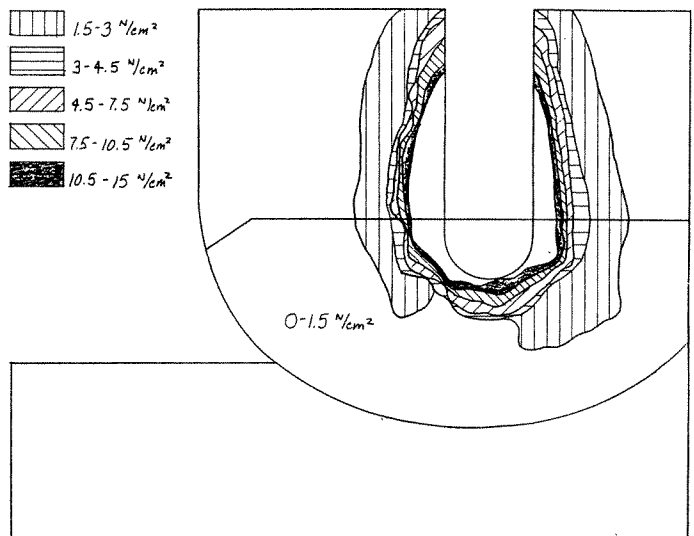

Figure 8.
von Mises stresses for seated male.

Table 3.
Buttock/cushion interface stresses.

Position	σ_3 (Pa)	$\sigma_{\text{von Mises}}$ (Pa)	Oxford Pressure Monitor (Pa)
Male—supine	2,978	2,487	4,100
Male—seated	16,921	16,981	not available
Female—supine	4,667	4,384	2,800
Female—seated	14,955	12,465	not available

have appeared to be quite significant (24). Specific stress values in the soft tissue at the buttock-cushion interface are given for each loading condition in **Table 3**. Some experimental data generated at the buttock-cushion interface measured with an Oxford pressure monitor are also given in **Table 3**. The computational principal stresses are approximately 50 percent different from the experimentally determined pressures. As more information about materials, large deformations, and nonlinearities is introduced into the model, the results will improve.

DISCUSSION

The main objective of this study is to show that finite element analysis can be used as a tool in cushion design. To be truly useful, the model must be capable of being used in a desktop computing environment. Some limitations were placed on the size of the model and the complexity of analysis used so that it could be handled in this environment.

Material Properties of the Soft Tissue

While the material properties of the soft tissue exhibit nonlinear behavior, they were modeled linearly in this model as a first approximation. Data are available to expand this model into the range of nonlinear materials. This type of analysis will become more practical as computers continue to become more powerful.

Experimental vs. Computational Results

Deflection of the soft tissue under the right ischial tuberosity was determined experimentally with MRI by imaging subjects in both free-hanging and body weight loading conditions.

Buttock-cushion interface pressures in certain loading conditions were measured experimentally using an Oxford pressure monitor. These pressures were compared with the minimum principal stresses computed for the interface. Stresses and displacements are consistently higher in the seated position than in the supine position throughout the soft tissue. This is due not only to the increased loads applied in the seated cases but also to the different material properties used.

While buttock-cushion interface pressures are used in cushion design, surgical evidence suggests that decubitus ulcers form within the internal tissues and progress toward the surface. The stress contour in **Figure 7**, for example, shows the change in stress within the soft tissues. Stresses at the buttock-cushion interface and in the tissues surrounding the ischial tuberosity are shown in **Table 4**. For the male subject in the supine position, the stress increases by a factor of 3.5 from the buttock-cushion interface to the element beneath the ischial tuberosity. In the seated position, the stress increases by a factor of 4.5. For the female subject in the supine position, the stress increases by a factor of 11 from the buttock-cushion interface to the element beneath the

Table 4.
Interface and internal stresses.

Position	Interface σ_3 (Pa)	Ischial Tuberosity σ_3 (Pa)
Male—supine	2,978	10,631
Male—seated	16,921	74,112
Female—supine	4,667	51,526
Female—seated	14,955	204,850

ischial tuberosity. In the seated position, the stress increases by a factor of 13.5.

Literature discussing the formation of decubitus ulcers gives ranges of interface pressures associated with their onset (7,24,25). This diverse range of values indicates that other factors, such as internal stress, may be better predictors of formation of decubiti. Results from this initial model are not adequate to suggest any relationship between interface pressures and internal stresses. A study with more subjects and a more advanced model would be necessary to begin to define that relationship.

CONCLUSION

Although the model contained many approximations regarding material properties and loading, the difference between computational and experimental results indicate that this is a feasible approach for modeling healthy buttocks tissue on a custom-contoured cushion. Magnetic Resonance Imaging can be used to generate the geometry of a model of an anatomical structure although more automation could greatly reduce the tedium in this process. Introduction of an elastic foundation boundary condition led to computational results that approached the experimentally measured results.

The clinical significance of the stress results is that there is no clear correlation between interface pressures and the internal stresses. Variation in the change in stress from the buttock-cushion interface to the ischial tuberosity may explain the citation of different stress values in the literature for the initiation of decubiti. The correlation between the magnitudes of stress in the internal tissues and formation of ulcers is unknown at this time.

REFERENCES

- Rosen JM, Hentz VR, Perakash I. The plastic surgical management of pressure sores. In: Proceedings of the 39th Annual Conference on Engineering in Medicine and Biology. 1986:281.
- Reddy NP, Brunski JB, Patel H, Cochran GVB. Stress distributions in a loaded buttock with various seat cushions. *Adv Bioeng* 1980:97-100.
- Brunski JB, Roth V, Reddy N, Cochran GVB. Finite element stress analysis of a contact problem pertaining to formation of pressure sores. *Adv Bioeng* 1980:53-6.
- Chow WW, Odell EI. Deformation and stresses in soft body tissues of a sitting person. *J Biomech Eng* 1978:100:79-87.
- Kett RL, Levine SP. A dynamic model of tissue deflection in a seated individual. In: Proceedings of the 10th Annual RESNA Conference, 1987 June; San Jose, CA, Washington, DC: RESNA Press, 1987:524-6.
- Cooper R, Ward C, Ster J. Characterization and development of a resistive sensor for measuring cushion interface force. In: Proceedings of the RESNA International '92 Conference, 1992 June, Toronto, ON, Washington, DC: RESNA Press, 1992:210-2.
- Chung KC. Tissue contour and interface pressure on wheelchair cushions (Dissertation). Charlottesville, VA: University of Virginia, 1987.
- Protz PR, Chung KC. Implementing magnetic resonance imaging for the quantification of load-bearing buttocks tissues. In: Proceedings of the 13th Annual RESNA Conference, 1990 June, Washington, DC: RESNA Press, 1990:109-10.
- Bentzen SM, Hvid I, Jorgensen J. Mechanical strength of tibial trabecular bone evaluated by X-ray computed tomography. *J Biomech* 1987:20:743-52.
- Jastrzebski ZD. The nature and properties of engineering materials. 2nd ed. New York: Wiley, 1977.
- Fung YC. Biomechanics: mechanical properties of living tissues. New York: Springer-Verlag, 1981.
- Fleming DG, Feinberg BN. Handbook of engineering in medicine and biology. Boca Raton, FL: CRC Press, 1976:254.
- Reilly DT, Burstein AH. The elastic and ultimate properties of compact bone tissue. *J Biomech* 1975:8:393-405.
- McElhaney JH, Fogle JL, Melvin JW, Haynes RR, Roberts VL, Alem NM. Mechanical properties of cranial bone. *J Biomech* 1970:3:495-511.
- Vannah WM, Childress DS. An investigation of the three-dimensional mechanical response of bulk muscular tissue: experimental methods and results. *ASME Symposium on Computational Methods in Biomechanics*, 1988.
- Cowin SC, Van Buskirk WC, Ashman RB. Properties of bone. In: Skalak R, Chien S, eds. *Handbook of bioengineering*. New York: McGraw-Hill, 1987:2.1-27.
- Reilly DT, Burstein AH, Frankel VH. The elastic modulus of bone. *J Biomech* 1974:7:271-5.
- Steege JW, Schnur DS, Childress DS. Prediction of pressure at the below-knee socket interface by finite element analysis. In: Stein JL, ed. *ASME Symposium on Biomechanics of Normal and Prosthetic Gait*. Boston, MA. B10-7B, BED-4, DSC-7:1987:39-43.
- Gordon JR. Control algorithms and mechanical components for an automatic body contour measurement system (Thesis). Charlottesville, VA: University of Virginia, 1989.
- Brienza D, Gordon JR, Thacker JG. A comparison of force transducers suitable for an automatic body support contouring system. In: Proceedings of the 12th Annual RESNA Conference, 1989 June; New Orleans, LA, Washington, DC: RESNA Press, 1989:238-9.

21. Bennett L. Transferring load to flesh—part II. Analysis of compressive stress. *Bull Prosthet Res* Fall 1971:45-63.
22. Bennett L, Patel H. Transferring load to flesh—part IX. Cushion stiffness effects. *Bull Prosthet Res* 1979:10:31.
23. Anthropometric Source Book, Volume I: anthropometry for designers. NASA Reference Publication 1024. 1978:IV-31-9.
24. Kenedi RM, Cowden JM, Seales JT. *Bedsore biomechanics*. London: University Park Press, 1976.
25. Bush CA. Study of pressures on skin under ischial tuberosities and thighs during sitting. *Arch Phys Med Rehabil* 1969:50:207-13.