

Three dimensional mirror symmetry beyond ADE quivers and Argyres-Douglas theories

Anindya Dey

*Department of Physics and Astronomy, Johns Hopkins University,
3400 North Charles Street, Baltimore, MD 21218, U.S.A.*

E-mail: anindya.hepth@gmail.com

ABSTRACT: Mirror symmetry, a three dimensional $\mathcal{N} = 4$ IR duality, has been studied in detail for quiver gauge theories of the ADE -type (as well as their affine versions) with unitary gauge groups. The A -type quivers (also known as linear quivers) and the associated mirror dualities have a particularly simple realization in terms of a Type IIB system of D3-D5-NS5-branes. In this paper, we present a systematic field theory prescription for constructing 3d mirror pairs beyond the ADE quiver gauge theories, starting from a dual pair of A -type quivers with unitary gauge groups. The construction involves a certain generalization of the S and the T operations, which arise in the context of the $SL(2, \mathbb{Z})$ action on a 3d CFT with a $U(1)$ 0-form global symmetry. We implement this construction in terms of two supersymmetric observables — the round sphere partition function and the superconformal index on $S^2 \times S^1$. We discuss explicit examples of various (non- ADE) infinite families of mirror pairs that can be obtained in this fashion. In addition, we use the above construction to conjecture explicit 3d $\mathcal{N} = 4$ Lagrangians for 3d SCFTs, which arise in the deep IR limit of certain Argyres-Douglas theories compactified on a circle.

KEYWORDS: Duality in Gauge Field Theories, Extended Supersymmetry, Supersymmetric Gauge Theory, Supersymmetry and Duality

ARXIV EPRINT: [2004.09738](https://arxiv.org/abs/2004.09738)

Contents

1	A brief summary of the paper	1
1.1	Background and the basic idea of the paper	1
1.2	Summary of the main results	8
1.3	Future directions	11
2	$\mathcal{N} = 4$ mirror symmetry and linear quivers: generalities	14
2.1	Supermultiplets and Lagrangian description	14
2.2	IR physics of 3d $\mathcal{N} = 4$ theories and mirror symmetry	17
2.3	Checking mirror symmetry using RG flow invariant observables	20
2.4	Mirror symmetry as S-duality in type IIB construction: linear quivers	23
3	Generating mirrors from linear quiver pairs using S-type operations	28
3.1	Elementary S -type and T -type operations on a generic quiver	29
3.2	Construction of generic quivers from linear quivers using S -type operations	34
3.3	Reading off the dual gauge theory	42
3.4	Simple illustrative example: flavored \widehat{A}_{n-1} quiver	45
4	Non-ADE mirror duals from Abelian S-type operations	49
4.1	Abelian S -type operations: general discussion	50
4.1.1	Gauging	50
4.1.2	Flavoring-gauging	51
4.1.3	Identification-gauging	55
4.1.4	Identification-flavoring-gauging	56
4.1.5	A qualitative description of the dual operations	59
4.2	Examples of Abelian quiver pairs	60
4.2.1	Family I $_{[n,l,p]}$: a single closed loop attached to a linear quiver tail	60
4.2.2	Family II $_{[n,l_1,l_2,p_1,p_2]}$: two closed loops attached to a linear quiver tail	65
4.3	Examples of non-Abelian quiver pairs	72
4.3.1	Family III $_{[p_1,p_2,p_3]}$: a single closed loop with bifundamental matter attached to a linear quiver tail	72
4.3.2	Family IV $_{[p_1,p_2,p_3]}$: a single closed loop with bifundamental and rank-2 antisymmetric matter attached to a linear quiver tail	75
5	3d mirror pairs for class \mathcal{S} SCFTs on a circle	83
5.1	AD theories, (G, G') theories and Lagrangian 3d mirrors	84
5.2	Mirror pairs: 4d SCFTs from a single irregular puncture	87
5.2.1	Trivial case: (A_1, A_{2p-1}) theories for generic p	87
5.2.2	(A_2, A_{3p-1}) theories for generic p	87
5.2.3	(A_3, A_{4p-1}) theories with generic p	87
5.3	Mirror pairs: 4d SCFTs from a single irregular puncture and a regular puncture	89

5.3.1	Trivial case: (A_1, D_{2p+2}) theories for generic p	89
5.3.2	(A_2, D_{3p+2}) theories for generic p	90
5.3.3	4d SCFTs from an irregular puncture and a maximal puncture	90
A	Flavored D_4 quivers: dependence of the dual Lagrangian on \mathcal{P}	91
A.1	Abelian gauging operations	93
A.2	Abelian flavoring-gauging operation	96
B	Superconformal index on $S^2 \times S^1$	99
B.1	Definition and localization formula	99
B.2	3d $\mathcal{N} = 4$ mirror symmetry	102
C	S-type operations in terms of the superconformal index	103
C.1	Generic S -type operations and their duals	104
C.2	Abelian elementary S -type operations	108
C.2.1	Gauging	108
C.2.2	Flavoring-gauging	109
C.2.3	Identification-gauging	110
C.2.4	Identification-flavoring-gauging	111
C.3	Sample computation: flavored \widehat{A}_{n-1} quiver and family $I_{[n,l,p]}$	113

1 A brief summary of the paper

1.1 Background and the basic idea of the paper

In spite of the impressive success of perturbative QFT, the study of non-perturbative/strongly coupled aspects of a QFT remains a challenge for theorists. Probing the physics in this regime requires new computational tools, and there has been substantive progress in this area over the last thirty years. In addition to String Dualities, advances in AdS/CFT, as well as the more recent developments in the fields of Localization Methods and Conformal Bootstrap, have provided us with a powerful toolbox for studying non-perturbative phenomena in QFTs, particularly ones with supersymmetry.

A rather ubiquitous phenomenon in QFTs, living in different space-time dimensions, is the existence of UV/IR dualities. Broadly speaking, existence of such a duality implies that a set of theories, which have completely different descriptions (theories with different Lagrangians, for example) at a given energy scale, are described by a common physical theory at another energy scale. The theory at the latter scale is often a strongly-coupled interacting CFT. In addition to High Energy Theory, the study of these dualities play a significant role in other branches of physics like Condensed Matter Theory. Given the strongly coupled nature of the problem, some direct or indirect handle on the non-perturbative physics of QFTs is necessary to probe these dualities. A special subclass of such dualities in $(2+1)$ space-time dimensions will be our primary focus in this paper.

There has been significant progress in our understanding of UV/IR dualities for supersymmetric QFTs in the last decade, largely due to the development of a set of computational techniques which allows one to calculate certain supersymmetric observables exactly. These are collectively referred to as “Localization Techniques/Methods” (see [1] for a recent review). The basic idea involves putting a supersymmetric QFT, with a given Lagrangian in flat space, on a d -dimensional Riemannian manifold \mathcal{M}_d , such that the theory has an unbroken fermionic generator Q which squares to a bosonic symmetry \mathcal{L} . A systematic prescription for obtaining the supersymmetric Lagrangian on \mathcal{M}_d , using the rigid limit of an appropriate supergravity theory with background auxiliary fields, was given in [2]. In addition, one can turn on background gauge fields for the non-spacetime global symmetries of the theory. The path integral corresponding to a supersymmetric observable on \mathcal{M}_d can then be deformed in a way such that it localizes to a set of “saddle-point” configurations. For a sufficiently restrictive bosonic symmetry \mathcal{L} , this set may reduce to a set of finite number of isolated points on the moduli space. Given the set of saddle-point configurations, one can attempt to compute the functional determinant associated with the fluctuations of fields around these configurations and thereby evaluate the path integral exactly. For the purpose of this paper, we will consider supersymmetric observables for which the answer can be expressed as a matrix integral (with possible sum over flux sectors) over some bosonic zero mode(s) with the integrand being completely determined by the gauge group and matter content of the Lagrangian. Schematically, such a supersymmetric observable computed using localization in a theory T , will have the following form:¹

$$Z^{(T)}(\hat{A}) = \int [d\varphi] Z_{\text{classical}}^{(T)}(\varphi, \hat{A}) Z_{\text{quantum}}^{(T)}(\varphi, \hat{A}), \tag{1.1}$$

where φ collectively denotes the bosonic zero modes, and \hat{A} denotes a space-time-independent background gauge field² associated with a 0-form global symmetry. $Z_{\text{classical}}$ is the part of the matrix integrand that arises from simply evaluating the (possibly regularized) classical action on the saddle point configuration. Z_{quantum} captures the rest of the functional determinant and is completely determined by the gauge group as well as the representations of the matter multiplets under the gauge and the global symmetries.

A very important feature of the localization answer is that it is independent of dimensionful coupling constants and therefore invariant under a renormalization group flow. This implies that the observable, although computed using a weakly-coupled description, can be used to extract information about the strongly-coupled CFT.³ The RG-invariant localization answer is particularly suited for studying the UV/IR dualities. For a pair of theories (X, Y) flowing to the same CFT in the UV/IR, RG-invariance of the supersymmetric observable Z would imply

$$Z^{(X)}(\hat{A}) = Z^{(Y)}(\hat{A}). \tag{1.2}$$

¹There can also be a sum over flux sectors that we are choosing to ignore in these schematic equations.

²In supersymmetric theories, \hat{A} should be understood as a bosonic component of a background vector multiplet.

³For example, the superconformal index in three dimensions counts primary operators of the IR SCFT, the three sphere partition function is related to entanglement entropy across a disc, and so on.

The above equation constitutes a very non-trivial check of the duality statement, since one is comparing a function of the background gauge fields as opposed to a number. In particular, the map of the background gauge fields across the duality can be non-trivial.

Historically, the discovery and analysis of these UV/IR dualities, beyond simple examples, have relied heavily on String Theory dualities. Localization techniques, on the other hand, provide an efficient way for studying dualities, from a purely QFT perspective. It is natural to ask whether, within a given class of dualities, one can use these tools to construct a systematic field theory prescription for generating new dualities, starting from certain “basic” ones. A related challenge for any such program would be to find QFT dualities which are not realized by the standard String Theory constructions. We will try to answer these issues for a class of IR dualities in three dimensions, explaining what we mean by “basic” dualities along the way.

In order to implement such a program for 3d IR dualities, we would first need to discuss a prescription for constructing a new 3d CFT from a given 3d CFT. In [3], the author studied an $SL(2, \mathbb{Z})$ action on 3d CFT $X[\hat{A}]$ with a global $U(1)$ symmetry with a background gauge field \hat{A} . The action of the $SL(2, \mathbb{Z})$ generators T and S are given as

$$\begin{aligned} T : \mathcal{L}(\hat{A}) &\rightarrow \mathcal{L}(\hat{A}) + \frac{1}{4\pi} \hat{A} \wedge d\hat{A}, \\ S : \mathcal{L}(\hat{A}) &\rightarrow \mathcal{L}(a) + \frac{1}{2\pi} \hat{B} \wedge da \quad (a \text{ dynamical}), \end{aligned} \tag{1.3}$$

where \hat{B} is the background gauge field for the topological $U(1)_J$ symmetry in 3d. The action of the S generator, which amounts to gauging a global symmetry of the theory $X[\hat{A}]$, generically gives a new 3d CFT $X'[\hat{B}]$, i.e.

$$S : X[\hat{A}] \mapsto X'[\hat{B}]. \tag{1.4}$$

In this paper, we will present a certain generalization of the S -operation on a class of 3d CFTs, which have a weakly coupled description with a manifest global symmetry subgroup $G_{\text{global}}^{\text{sub}} = \prod_{\gamma} U(M_{\gamma})$. We will refer to this class of 3d CFTs as class \mathcal{U} . Similar to the S -operation above, the generalized operation will allow us to construct new 3d CFTs from a given 3d CFT X in the class \mathcal{U} . We will refer to this generalized version as an “elementary S -type operation”, and define it momentarily.

To begin with, we introduce a set of four independent operations on a generic 3d Lagrangian theory \mathcal{T} (not necessarily in \mathcal{U}), where the operations act locally on a given global symmetry factor K_{γ} (labelled by γ):

1. **Gauging (\mathcal{G}^{γ}):** Promotes K_{γ} to a gauge group, adding a $U(1)_J$ background field, if K_{γ} is unitary.
2. **Flavoring (\mathcal{F}^{γ}):** adds matter fields charged under K_{γ} , and turns on background gauge fields for an additional global symmetry G_F^{γ} associated with the added matter.
3. **Identification ($\mathcal{I}_{\gamma'}^{\gamma}$):** identifies K_{γ} with other factors $K_{\gamma'}$ (Lie group of the same type and same rank as K_{γ}) in the global symmetry of \mathcal{T} , and turns on appropriate background gauge fields for the new global symmetry that the operation leads to.
4. **Defects (\mathcal{D}^{γ}):** turns on defects for K_{γ} (Wilson lines or vortex lines, for example).

Now consider a Lagrangian theory X in the class \mathcal{U} . Let us pick the α -th unitary factor $U(M_\alpha)$ in the global symmetry subgroup $G_{\text{global}}^{\text{sub}} = \prod_\gamma U(M_\gamma)$, and split it as $U(M_\alpha) \rightarrow U(r_\alpha) \times U(M_\alpha - r_\alpha)$. We will refer to the resultant theory as (X, \mathcal{P}) , where \mathcal{P} denotes the data which encodes how the $U(r_\alpha)$ background gauge fields are chosen from those of $U(M_\alpha)$.⁴ Also, let us label the $U(r_\alpha)$ factor in (X, \mathcal{P}) as α' . We will find it convenient to consider a slightly general situation, where we split multiple unitary factors $U(M_\beta) \rightarrow U(r_\alpha)_\beta \times U(M_\beta - r_\alpha)$ ($\beta \neq \alpha$), in addition to the α -th unitary factor. We will call the resultant theory $(X, \{\mathcal{P}_\beta\})$, and label the $U(r_\alpha)_\beta$ factors as β' . An identification operation which identifies all the nodes labelled β' with α' will be denoted as $\mathcal{I}_{\beta'}^{\alpha'}$, following the above notation.

We will now define a “ \mathcal{Q} -operation” $\mathcal{Q}_{\mathcal{P}}^\alpha$ acting locally at the unitary factor α of the Lagrangian theory X in the following fashion:

$$\mathcal{Q}_{\mathcal{P}}^\alpha(X) := (\mathcal{G}^{\alpha'})^{n_4} \circ (\mathcal{F}^{\alpha'})^{n_3} \circ (\mathcal{I}_{\beta'}^{\alpha'})^{n_2} \circ (\mathcal{D}^{\alpha'})^{n_1}(X, \{\mathcal{P}_\beta\}), \quad (n_i = 0, 1, \forall i) \quad (1.5)$$

$$:= (G_{\mathcal{P}}^\alpha)^{n_4} \circ (F_{\mathcal{P}}^\alpha)^{n_3} \circ (I_{\mathcal{P}}^\alpha)^{n_2} \circ (D_{\mathcal{P}}^\alpha)^{n_1}(X). \quad (1.6)$$

The first equality is the definition of \mathcal{Q} -operation on X . It states that the action of a given operation $\mathcal{Q}_{\mathcal{P}}^\alpha$ at a unitary factor $U(M_\alpha)$ (labelled α) on X , is defined by acting on the theory $(X, \{\mathcal{P}_\beta\})$ a certain combination of $\mathcal{G}, \mathcal{F}, \mathcal{I}$ and \mathcal{D} -operations locally at the unitary factor $U(r_\alpha)$ (labelled α'). The specific combination is determined by the integers $\{n_i\}$. Note that the composition of the operations $\mathcal{F}, \mathcal{I}, \mathcal{D}$ is commutative, but they do not commute with \mathcal{G} .

The second equality (1.6) defines a set of four basic \mathcal{Q} -operations (discussed in detail in section 3.1 for the specific case of 3d $\mathcal{N} = 4$ quivers) in terms of the operations $\mathcal{G}, \mathcal{F}, \mathcal{I}$ and \mathcal{D} , and gives a rule to compose them:

- **\mathcal{Q} -Gauging ($G_{\mathcal{P}}^\alpha$):** $G_{\mathcal{P}}^\alpha(X) = \mathcal{G}^{\alpha'}(X, \{\mathcal{P}_\beta\})$,
- **\mathcal{Q} -Flavoring ($F_{\mathcal{P}}^\alpha$):** $F_{\mathcal{P}}^\alpha(X) = \mathcal{F}^{\alpha'}(X, \{\mathcal{P}_\beta\})$,
- **\mathcal{Q} -Identification ($I_{\mathcal{P}}^\alpha$):** $I_{\mathcal{P}}^\alpha(X) = \mathcal{I}_{\beta'}^{\alpha'}(X, \{\mathcal{P}_\beta\})$,
- **\mathcal{Q} -defects ($D_{\mathcal{P}}^\alpha$):** $D_{\mathcal{P}}^\alpha(X) = \mathcal{D}^{\alpha'}(X, \{\mathcal{P}_\beta\})$.

In the rest of the paper, we will refer to these basic \mathcal{Q} -operations as gauging, flavoring, identification and defect operations respectively, acting on a theory X , and the original operations $\mathcal{G}, \mathcal{F}, \mathcal{I}$ and \mathcal{D} will never appear again.

We can now define the “elementary S -type operation” $\mathcal{O}_{\mathcal{P}}^\alpha$ on a global symmetry factor $U(M_\alpha)$ of X , as a special case of a $\mathcal{Q}_{\mathcal{P}}^\alpha$ operation which necessarily includes the gauging operation, i.e.

$$\mathcal{O}_{\mathcal{P}}^\alpha(X) := G_{\mathcal{P}}^\alpha \circ (F_{\mathcal{P}}^\alpha)^{n_3} \circ (I_{\mathcal{P}}^\alpha)^{n_2} \circ (D_{\mathcal{P}}^\alpha)^{n_1}(X), \quad (1.7)$$

where the r.h.s. is precisely defined in (1.6). The action of $\mathcal{O}_{\mathcal{P}}^\alpha$ on X gives a (generically) new 3d CFT X' , whose weakly coupled description has a different gauge group and matter

⁴See (3.1) for a concrete realization in the case of $\mathcal{N} \geq 2$ SUSY theories.

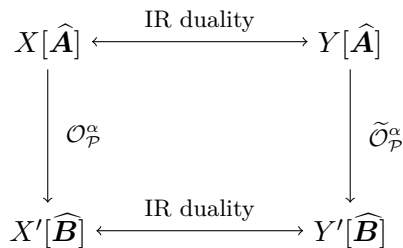

Figure 1. Generating new dual pairs using an elementary S -type operation.

content from the theory X . The elementary S -type operation $\mathcal{O}_{\mathcal{P}}^{\alpha}$ can therefore be thought of as an operation that acts on a 3d CFT $X[\widehat{\mathbf{A}}]$ and produces a new 3d CFT $X'[\widehat{\mathbf{B}}]$ (with or without defect), i.e.

$$\mathcal{O}_{\mathcal{P}}^{\alpha} : X[\widehat{\mathbf{A}}] \mapsto X'[\widehat{\mathbf{B}}], \tag{1.8}$$

where $\widehat{\mathbf{A}}$ denotes the $U(r_{\alpha})$ background gauge field. $\widehat{\mathbf{B}}$ collectively denotes the $U(1)_J$ background gauge field, background fields associated with the global symmetries coming from the flavoring/identification operations, as well as additional data for the defects, if any. In the trivial case, where $G_{\text{global}}^{\text{sub}} = U(1)$, and $\mathcal{O}_{\mathcal{P}}^{\alpha}$ is constituted of simply a gauging operation, the elementary S -type operation coincides with the action of the S generator in [3].

From (1.7), ignoring defect operations for the time being (which would be the case for most of this paper), an elementary S -type operation can be classified into four distinct types:

1. **Gauging:** $\mathcal{O}_{\mathcal{P}}^{\alpha}(X) = G_{\mathcal{P}}^{\alpha}(X)$.
2. **Flavoring-Gauging:** $\mathcal{O}_{\mathcal{P}}^{\alpha}(X) = G_{\mathcal{P}}^{\alpha} \circ F_{\mathcal{P}}^{\alpha}(X)$.
3. **Identification-Gauging:** $\mathcal{O}_{\mathcal{P}}^{\alpha}(X) = G_{\mathcal{P}}^{\alpha} \circ I_{\mathcal{P}}^{\alpha}(X)$.
4. **Identification-Flavoring-Gauging:** $\mathcal{O}_{\mathcal{P}}^{\alpha}(X) = G_{\mathcal{P}}^{\alpha} \circ F_{\mathcal{P}}^{\alpha} \circ I_{\mathcal{P}}^{\alpha}(X)$.

By definition, a “generic S -type operation” will be understood as a combination of elementary S -type operations of the four types listed above. Note that the construction (1.8) is completely independent of the existence or the amount of supersymmetry of $X[\widehat{\mathbf{A}}]$. In a similar fashion, one can define an “elementary T -type operation”, which turns on a Chern-Simons term for $U(r_{\alpha})$, and combine it with S -type operations to construct new 3d CFTs.

Given the map (1.8), one can now address the issue of constructing new dual pairs starting from a given dual pair. Suppose the theory $X[\widehat{\mathbf{A}}]$ is IR dual to the theory $Y[\widehat{\mathbf{A}}]$, where both theories have a weakly coupled description and X is in class \mathcal{U} . Then, given an S -type operation $\mathcal{O}_{\mathcal{P}}^{\alpha}$ on $X[\widehat{\mathbf{A}}]$, let us define a dual operation $\widetilde{\mathcal{O}}_{\mathcal{P}}^{\alpha}$ on $Y[\widehat{\mathbf{A}}]$,

$$\widetilde{\mathcal{O}}_{\mathcal{P}}^{\alpha} : Y[\widehat{\mathbf{A}}] \mapsto Y'[\widehat{\mathbf{B}}], \tag{1.9}$$

such that the pair of theories $(X'[\widehat{\mathbf{B}}], Y'[\widehat{\mathbf{B}}])$ are IR dual. This is summarized in the figure below.

The challenge then is to give a precise definition for the dual operation $\tilde{\mathcal{O}}_{\mathcal{P}}^\alpha$, given $(X[\hat{\mathbf{A}}], Y[\hat{\mathbf{A}}])$ and $\mathcal{O}_{\mathcal{P}}^\alpha$, which should also allow one to read off the theory $Y'[\hat{\mathbf{B}}]$, if it turns out to be Lagrangian (note that the IR dual of a Lagrangian theory is not necessarily Lagrangian). For theories where an RG-invariant observable computable using localization exists, as given in (1.1), this problem may be solved explicitly. For three space-time dimensions, this forces us to restrict ourselves to theories with $\mathcal{N} \geq 2$ supersymmetry. Given a pair of dual theories $(X[\hat{\mathbf{A}}], Y[\hat{\mathbf{A}}])$ and the S -type operation $\mathcal{O}_{\mathcal{P}}^\alpha$, one can then write explicit formulae for RG-invariant observables of $Y'[\hat{\mathbf{B}}]$ using (1.1) and (1.2). To begin with, the operation $\mathcal{O}_{\mathcal{P}}^\alpha$ can be implemented at the level of the supersymmetric observable in the following fashion:

$$Z^{(X')}(\hat{\mathbf{B}}) = \int [d\hat{\mathbf{A}}] \mathcal{Z}_{\mathcal{O}_{\mathcal{P}}^\alpha(X)}(\hat{\mathbf{A}}, \hat{\mathbf{B}}) Z^{(X)}(\hat{\mathbf{A}}), \tag{1.10}$$

where $\mathcal{Z}_{\mathcal{O}_{\mathcal{P}}^\alpha(X)}$ is an explicitly known operator that depends on the specific elementary S -type operation. The observable for the dual theory $Y'[\hat{\mathbf{B}}]$ then assumes the following schematic form (substituting (1.2) in (1.10), and changing the order of integration):

$$Z^{(Y')}(\hat{\mathbf{B}}) = \int [d\varphi'] \left(\int [d\hat{\mathbf{A}}] \mathcal{Z}_{\mathcal{O}_{\mathcal{P}}^\alpha(X)}(\hat{\mathbf{A}}, \hat{\mathbf{B}}) \right) Z_{\text{classical}}^{(Y)}(\varphi', \hat{\mathbf{A}}) Z_{\text{quantum}}^{(Y)}(\varphi', \hat{\mathbf{A}}) \tag{1.11}$$

where $Z^{(Y)}(\hat{\mathbf{A}}) = \int [d\varphi'] Z_{\text{classical}}^{(Y)}(\varphi', \hat{\mathbf{A}}) Z_{\text{quantum}}^{(Y)}(\varphi', \hat{\mathbf{A}})$.

The relation (1.11) is the definition of the dual operation $\tilde{\mathcal{O}}_{\mathcal{P}}^\alpha$ on the theory Y . If the theory $Y'[\hat{\mathbf{B}}]$ is Lagrangian, one should be able to rewrite $Z^{(Y')}(\hat{\mathbf{B}})$ in (1.11) in the standard form

$$Z^{(Y')}(\hat{\mathbf{B}}) = \int [d\varphi'] Z_{\text{classical}}^{(Y')}(\varphi', \hat{\mathbf{B}}) Z_{\text{quantum}}^{(Y')}(\varphi', \hat{\mathbf{B}}), \tag{1.12}$$

which allows one to read off the gauge group and matter content of $Y'[\hat{\mathbf{B}}]$ from the r.h.s. of the above equation. Note that this last step may not be easy to perform for a generic duality, and might involve some non-trivial manipulation of the matrix integral.

The strategy for generating dualities using S -type operations is now clear. For a given type of IR duality, we pick a convenient subset of dual theories (with (X, Y) Lagrangian and X in class \mathcal{U}) for which the duality is completely understood in terms of RG-invariant observables. We will refer to this as the set of “basic dualities” for the given IR duality. Picking (X, Y) from this set of basic dualities, one can now implement the construction of figure 1 step-wise to generate new dual pairs.

In the present paper, we will choose a specific IR duality for 3d $\mathcal{N} = 4$ theories, called mirror symmetry [4–7], to illustrate how our construction can be realized in a concrete setting. A discussion of more generic 3d $\mathcal{N} = 2$ dualities will be deferred to a future work. Mirror symmetry is a special IR duality for a pair of theories (X, Y) which interchanges the Coulomb branch of X with the Higgs branch of Y and vice-versa, in the deep IR regime. In particular, this implies that flavor symmetry (i.e. the Higgs branch global symmetry) on one side of the duality gets mapped to topological symmetry (i.e. Coulomb branch global symmetry) on the other side. Non-supersymmetric versions of such dualities appear

in a wide-range of condensed matter systems [8–10]. Recently, it was shown that these supersymmetric dualities can also generate a large class of bosonization dualities [11–14] via soft supersymmetry breaking [15, 16].

In the literature, mirror symmetry for quiver gauge theories of the ADE type (and their affine cousins) has been studied in a lot of detail [17–23]. This is essentially due to the fact that these theories have well-known realization in Type IIB String Theory [24–27] and M-Theory [17, 28, 29]. In particular, the A -type quivers with unitary gauge groups (also known as linear quivers) have a very simple realization in Type IIB, in terms of D3-branes on a line segment, along with NS5 and D5-branes. More recently, a large class of non-Lagrangian 3d SCFTs, whose mirror duals are Lagrangian, was also obtained using the dimensional reduction of 4d $\mathcal{N} = 2$ theories of class \mathcal{S} [30, 31]. In all these String Theory/M-Theory constructions, the QFT duality follows as a consequence of some String Duality.

One of the primary goals of this paper is to construct mirror dual quiver gauge theories beyond these ADE quiver examples, using the S -type operations described above. The strategy, as outlined before, is to start from a pair of basic dual theories (X, Y) , and implement one or more elementary S -type operation(s) defined above to obtain a new dual pair (X', Y') . As mentioned earlier, the theories (X, Y) must both have Lagrangian descriptions for the construction to work. Also, the precise localization procedure, as we will see later, requires knowing the mirror map, i.e. how flavor symmetries of X map to topological symmetries of Y . Given a Lagrangian quiver X in class \mathcal{U} , the mirror dual Y is generically not known. Therefore, a convenient choice of basic dualities is necessary. For the purpose of this paper, we will choose the set of basic dualities as the set of *good* linear quivers [27] with unitary gauge groups, where the mirror symmetry (including the mirror map) is completely understood, both from String Theory and QFT. With this choice of the pair (X, Y) , the construction of figure 1 can be seamlessly implemented to generate a new dual pair (X', Y') . In particular, the expression (1.11) greatly simplifies as we will see in section 3.3.

For the examples treated in this paper, the relevant elementary S -type operations are Abelian, i.e. they involve gauging of a single $U(1)$ global symmetry combined with flavoring and/or identification operations. Note that the generic S -type operations, built out of these elementary ones, can generate dualities for Abelian as well as non-Abelian theories, depending on the basic dual pair (X, Y) one starts from. Examples involving non-Abelian elementary S -type operations will be addressed in an upcoming paper.

The paper is organized as follows. Section 2 gives a brief review of the various aspects of 3d $\mathcal{N} = 4$ physics relevant for the paper. Section 3 sets up the general formalism for constructing new dualities, as outlined above. Section 3.1 introduces the S -type and T -type operations on a generic $\mathcal{N} = 4$ quiver in class \mathcal{U} , and discusses their realization in terms of a specific RG-invariant observable — the round 3-sphere partition function [32, 33]. Section 3.2 then discusses the partition function construction of quivers using elementary S -type operations from linear quivers (as well as more general quivers), while section 3.3 discusses the dual operations. A simple illustrative example, involving an affine A -type theory, is presented in section 3.4, while more involved examples involving (affine) D -type quivers are presented in appendix A. The S -type operations can also be implemented in terms of other RG-invariant observables. We present the analysis in terms of the $S^2 \times S^1$ superconformal index [34–36] (reviewed in appendix B) in appendix C.

Section 4 focuses on Abelian S -type operations and examples of new dual theories that can be constructed using them. Section 4.1 studies the Abelian version of the four different types of elementary S -type operations and their duals. Section 4.2 and section 4.3 then apply these operations to construct two infinite families of Abelian mirror pairs and two infinite families non-Abelian mirror pairs respectively, consisting of non- ADE -type quiver gauge theories in each case. These two subsections contain the main results of this paper in terms of constructing new mirror dualities.

Finally, using results of section 4.2 and section 4.3, we demonstrate in section 5 that 3d SCFTs, obtained by compactifying a large family of Argyres-Douglas (AD) theories on a circle and flowing to the IR, turn out to have Lagrangian descriptions. Our strategy in this case involves showing that the 3d Lagrangian mirror [31, 37] predicted by the class \mathcal{S} construction of a given AD theory, itself has a Lagrangian mirror. Note that we mean a manifestly $\mathcal{N} = 4$ Lagrangian in this context, and not a Lagrangian with less supersymmetry that flows to a theory with $\mathcal{N} = 4$ supersymmetry [38].

1.2 Summary of the main results

In this paper, we introduce a systematic field theory prescription for generating infinite families of 3d $\mathcal{N} = 4$ mirror quiver pairs, using S -type operations, as outlined in figure 1. We explicitly realize this program in terms of two RG-invariant supersymmetric observables — the S^3 partition function and the $S^2 \times S^1$ superconformal index, which can be computed using localization techniques. This is then applied to construct examples of dual pairs involving quiver gauge theories beyond the ADE -type. The main results of the paper can be summarized as follows:

Construction of mirror pairs from S -type operations. Consider a pair of dual quiver gauge theories (X, Y) where X is in class \mathcal{U} , with a Higgs branch global symmetry subgroup $G_{\text{global}}^{\text{sub}} = \prod_{\gamma} \text{U}(M_{\gamma})$. We first realize the construction of a new pair of dual theories (X', Y') starting from (X, Y) in terms of the S^3 partition function. In the matrix integral, the background vector multiplets for the Higgs branch global symmetry appear as real masses, while the twisted vector multiplets for the Coulomb branch global symmetry appear as real FI parameters. Supersymmetry demands that, in each case, the background multiplets live in the Cartan subalgebra of the respective global symmetry group. For a generic elementary S -type operation $\mathcal{O}_{\mathcal{P}}^{\alpha}$ on the quiver, the partition function of the theory $X' = \mathcal{O}_{\mathcal{P}}^{\alpha}(X)$ is given as (the more detailed form of this equation appears as (3.16) in the main text):

$$Z^{\mathcal{O}_{\mathcal{P}}^{\alpha}(X)}(\eta_{\alpha}, \mathbf{m}^{\mathcal{O}_{\mathcal{P}}^{\alpha}}, \boldsymbol{\eta}, \dots) = \int [d\mathbf{u}^{\alpha}] \mathcal{Z}_{\mathcal{O}_{\mathcal{P}}^{\alpha}(X)}(\mathbf{u}^{\alpha}, \{\mathbf{u}^{\beta}\}, \eta_{\alpha}, \mathbf{m}^{\mathcal{O}_{\mathcal{P}}^{\alpha}}) \cdot Z^{(X, \{P_{\beta}\})}(\{\mathbf{u}^{\beta}\}, \boldsymbol{\eta}, \dots), \quad (1.13)$$

which gives a concrete realization of (1.10). The function $Z^{(X, \{P_{\beta}\})}$ (given in (3.8)) is the partition function of the theory $(X, \{P_{\beta}\})$, which was introduced prior to (1.5). The explicit form of the operator $\mathcal{Z}_{\mathcal{O}_{\mathcal{P}}^{\alpha}(X)}$ is given in (3.17). The parameters \mathbf{u}^{β} denote the real masses in the Cartan subalgebra of the group $\text{U}(r_{\alpha})_{\beta}$, $\forall \beta$, while the parameters \mathbf{u}^{α} denote the masses for the chosen group $\text{U}(r_{\alpha})_{\alpha}$ with which the groups $\text{U}(r_{\alpha})_{\beta}$ (for $\beta \neq \alpha$)

will be identified by the S -type operation $\mathcal{O}_{\mathcal{P}}^{\alpha}$. The parameters η_{α} and $\mathbf{m}^{\mathcal{O}_{\mathcal{P}}^{\alpha}}$ denote the FI parameter for the $U(r_{\alpha})$ gauge group and the masses for the global symmetry introduced by the identification and/or flavoring operation respectively. Also, $\boldsymbol{\eta}$ collectively denotes the FI parameters of X , and the “...” in the argument of $Z^{(X, \{P_{\beta}\})}$ denote mass parameters of X that remain unaffected by the S -type operation. For the special case of X being a linear quiver, the corresponding equation is given in (3.22).

The partition function of the dual theory $Y' = \tilde{\mathcal{O}}_{\mathcal{P}}^{\alpha}(Y)$ can then be written in the following form (appears as (3.59) in the main text):

$$\begin{aligned} & Z^{\tilde{\mathcal{O}}_{\mathcal{P}}^{\alpha}(Y)}(\mathbf{m}'(\boldsymbol{\eta}, \eta_{\alpha}); \boldsymbol{\eta}'(\mathbf{m}^{\mathcal{O}_{\mathcal{P}}^{\alpha}}, \dots)) \\ &= \int \prod_{\gamma'} [d\boldsymbol{\sigma}^{\gamma'}] \mathcal{Z}_{\tilde{\mathcal{O}}_{\mathcal{P}}^{\alpha}(Y)}(\{\boldsymbol{\sigma}^{\gamma'}\}, \mathbf{m}^{\mathcal{O}_{\mathcal{P}}^{\alpha}}, \eta_{\alpha}, \boldsymbol{\eta}) \cdot Z_{\text{int}}^{(Y, \{P_{\beta}\})}(\{\boldsymbol{\sigma}^{\gamma'}\}, \mathbf{m}^Y(\boldsymbol{\eta}), \boldsymbol{\eta}^Y(\{\mathbf{u}^{\beta} = 0\}, \dots)), \end{aligned} \quad (1.14)$$

which gives a concrete realization of (1.11). The function $Z_{\text{int}}^{(Y, \{P_{\beta}\})}$ is the full integrand for the partition function matrix integral of $(Y, \{P_{\beta}\})$, defined in (3.48). The masses and FI parameters of Y' are denoted as $(\mathbf{m}', \boldsymbol{\eta}')$, while $(\mathbf{m}^Y, \boldsymbol{\eta}^Y)$ denote the same for the quiver gauge theory Y . $\mathcal{Z}_{\tilde{\mathcal{O}}_{\mathcal{P}}^{\alpha}(Y)}$ is a function that can be formally written as a Fourier transform of the operator $\mathcal{Z}_{\mathcal{O}_{\mathcal{P}}^{\alpha}(X)}$:

$$\mathcal{Z}_{\tilde{\mathcal{O}}_{\mathcal{P}}^{\alpha}(Y)} = \int [d\mathbf{u}^{\alpha}] \mathcal{Z}_{\mathcal{O}_{\mathcal{P}}^{\alpha}(X)}(\mathbf{u}^{\alpha}, \{\mathbf{u}^{\beta}\}, \eta_{\alpha}, \mathbf{m}^{\mathcal{O}_{\mathcal{P}}^{\alpha}}) \cdot \prod_{\beta} e^{2\pi i (g_{\beta}^i(\{\boldsymbol{\sigma}^{\gamma'}\}, P_{\beta}) + b_{\beta}^{il} \eta_l) u_i^{\beta}}, \quad (1.15)$$

where $g_{\beta}^i(\{\boldsymbol{\sigma}^{\gamma'}\}, P_{\beta})$ is a linear function in the variables $\{\boldsymbol{\sigma}^{\gamma'}\}$, that can be read off from the mirror map relating mass parameters of X and FI parameters of Y , while b_{β}^{il} are integer-valued matrices defined in (3.57). For the special case of (X, Y) being linear quivers, the functions g_{β}^i are known a priori from the Type IIB construction, and the partition function for the dual theory is given in (3.55). If the theory Y' is Lagrangian, then the matrix integral on the r.h.s. of (1.14) can be recast into the standard form for a Lagrangian theory, such that the gauge group and the matter content can be read off. Note that the computation of the dual partition function essentially boils down to computing the function $\mathcal{Z}_{\tilde{\mathcal{O}}_{\mathcal{P}}^{\alpha}(Y)}$ in (1.15).

Using the general formulae (1.13), (1.14) and (1.15), we write down the dual partition functions for the four distinct types of elementary S -type operations — gauging, flavoring-gauging, identification-gauging, and identification-flavoring-gauging. We refer the reader to section 3.2 and section 3.3 for details.

The above construction can also be implemented in terms the $S^2 \times S^1$ superconformal index. The equations analogous to (1.13), (1.14) and (1.15) are given by (C.11), (C.19) and (C.20) respectively.

Abelian S -type operations and their duals. In section 4.1, we work out the general rules for the dual operations associated with the four distinct types of elementary Abelian S -type operations, in terms of the S^3 partition function. For the constituent flavoring operations, we restrict ourselves to hypermultiplets with charge 1 under the new $U(1)$ gauge group. Given any dual pair of quiver gauge theories (X, Y) with X in class \mathcal{U} , we show explicitly that the dual theory Y' is a Lagrangian theory for each of the four operations.

In each case, we first give the formula for the dual partition function for a generic quiver pair (X, Y) , and then discuss the special case where (X, Y) are linear quivers. We make the following general observations:

- For gauging and identification-gauging operations, the function $\mathcal{Z}_{\tilde{\mathcal{O}}_{\mathcal{P}}^{\alpha}(Y)}$ in (1.14) turns out to be a single delta function. This implies that the dual theory $\tilde{\mathcal{O}}_{\mathcal{P}}^{\alpha}(Y)$ is given by ungauging a single $U(1)$ factor from the gauge group of Y . The precise $U(1)$ being ungauged depends on the precise form of the functions g_{β} on the r.h.s. of (1.15). The related equations can be found in (4.5) and (4.25) respectively in the main text.
- For flavoring-gauging and identification-flavoring-gauging operations, the function $\mathcal{Z}_{\tilde{\mathcal{O}}_{\mathcal{P}}^{\alpha}(Y)}$ in (1.14) is made up of Lagrangian building blocks (up to some overall phase factors). This leads to a Lagrangian theory $\tilde{\mathcal{O}}_{\mathcal{P}}^{\alpha}(Y)$. The related equations can be found in (4.13) and (4.32) respectively in the main text.

The above findings lead to the following result. Consider a dual pair of quiver gauge theories (X, Y) , and an Abelian S -type operation involving a sequence of the elementary operations, acting on X . Using the results above, one can readily show that the resultant theory X' is guaranteed to have a Lagrangian mirror dual Y' , which can be worked out explicitly.

These results on Abelian S -type operations can also be obtained using the superconformal index on $S^2 \times S^1$. The relevant discussion can be found in appendix C.2.

Explicit examples of mirror pairs beyond ADE quivers. Using the general rules for Abelian S -type operations derived in section 4.1, we construct four infinite families of dual quiver pairs, by a sequence of elementary Abelian S -type operations starting from a pair of linear quiver gauge theories (X, Y) in each case. The quiver gauge theories we consider have the following generic features:

1. **Loops attached to a linear quiver tail:** loops built out of gauge nodes and hypermultiplets in appropriate representations, such that one or more of the gauge nodes are attached to linear quiver tail(s).
2. **Loops with multiple edges:** loops built out of gauge nodes and hypermultiplets, such that one or more pairs of gauge nodes are connected by multiple hypermultiplets transforming in a given representation of the associated gauge groups.

Table 1 lists the four infinite families of dual quiver gauge theories. Note that Family I and Family II consist of Abelian quiver gauge theories, while Family III and Family IV consist of non-Abelian quiver gauge theories. The details of the partition function computation for these dual pairs can be found in section 4.2 and section 4.3 respectively. As mentioned earlier, these results can be obtained using the superconformal index as well, and the rules for the Abelian S -type operations, necessary for constructing the duals in this paper, are worked out in appendix C.2. We therefore check every proposed duality using two RG-invariant supersymmetric observables — the three-sphere partition function

and the superconformal index. For the sake of brevity, however, we will only include a sample computation in the paper for the index, given in section C.3. Other examples can be readily checked using the Abelian S -type operations for the index in appendix C.2, in a fashion analogous to the S^3 partition function.

3d $\mathcal{N} = 4$ Lagrangians for Argyres-Douglas theories reduced on a circle. We propose explicit $\mathcal{N} = 4$ Lagrangians for 3d $\mathcal{N} = 4$ SCFTs which arise by putting certain 4d Argyres-Douglas (AD) theories on a circle and flowing to the IR. These 4d SCFTs can be constructed in class \mathcal{S} [31, 39] by a twisted compactification of a 6d (2,0) A_{N-1} theory on a Riemann sphere with an irregular puncture with/without a single regular puncture. The 3d mirrors of some of these SCFTs are known to be Lagrangian, and can be constructed using the 6d description — we will refer to them as “class \mathcal{S} mirrors”. The list of 4d SCFTs with Lagrangian class \mathcal{S} mirrors includes the (G, G') theories of Cecotti-Neitzke-Vafa [40] of the type $(A_s, A_{(s+1)p-1})$ and $(A_s, D_{(s+1)p+2})$ (where s and p are positive integers). Our strategy is to show that the class \mathcal{S} mirrors associated with these 4d SCFTs have Lagrangian mirrors themselves, which in turn implies that the original 3d SCFT has a Lagrangian description. Table 2 summarizes the class \mathcal{S} mirror and the Lagrangian that we propose for a given family of AD theories. Given the class \mathcal{S} mirror, the proposed Lagrangian can be read off from table 1 — Family I, II and IV respectively — for appropriate choices of the integer parameters. A more detailed analysis of the physics of these 3d theories will be presented in a future paper.

1.3 Future directions

Before embarking on the main text of the paper, we would like to briefly comment on certain issues that have not been addressed in this work, but will be discussed in upcoming papers.

- **Examples of dualities from non-Abelian S -type operations:** in this paper, we have restricted ourselves to examples of mirror symmetry which can be constructed using Abelian S -type operations only. In a paper currently under preparation [41], we show that a generic Non-Abelian S -type operation can be “abelianized” i.e. written in terms of a set of Abelian S -type operations. A much larger class of mirror duals can be generated using the construction above, once these Non-Abelian S -type operations are incorporated.
- **Duality maps for defects beyond linear quivers:** even for Abelian S -type operations discussed in this paper, we have chosen not to turn on the defect operations. Incorporating them gives a powerful tool for analyzing the map of defect operators across the duality. This is especially relevant for dualities beyond linear quivers, where the aforementioned defect operators do not have a known realization in Type IIB String Theory. Defects for Non-Abelian S -type operations enrich the story further. We explore these directions in a work currently in progress.
- **3d $\mathcal{N} = 2$ dualities:** generic dualities in 3d $\mathcal{N} = 2$ gauge theories with Chern-Simons terms can also be generated from a set of basic dualities, in a way analogous

Family	Theory X	Theory Y
$I_{[n,l,p]}$		
$II_{[n,l,l_1,l_2,p_1,p_2]}$		
$III_{[p_1,p_2,p_3]}$		
$IV_{[p_1,p_2,p_3]}$		

Table 1. Summary table of non- ADE families of quiver gauge theories which are mirror dual to each other. The 3d $\mathcal{N} = 4$ quiver notation, used throughout this paper, is explained in figure 2. In particular, the line labelled \mathcal{A} in quiver X of Family IV denotes a hypermultiplet which transforms in the rank-2 antisymmetric representation of the $U(2)$ gauge group (i.e. has charge 2 under the $U(1) \subset U(2)$ and is a singlet under the $SU(2)$) and has charge 1 under the $U(1)$.

AD Theory	3d mirror from Class \mathcal{S}	Proposed Lagrangian
(A_2, A_{3p-1})		
(A_3, A_{4p-1})		
(A_2, D_{3p+2})		
$A_{2,p}^{\text{maximal}}$		

Table 2. Summary table of 3d mirror pairs associated with certain Argyres-Douglas theories realized in the class \mathcal{S} construction. The third column tabulates the proposed Lagrangians for the 3d SCFTs obtained by putting the Argyres-Douglas theory on a circle and flowing to the deep IR. The theory labelled $A_{2,p}^{\text{maximal}}$ in the fourth row is an AD theory realized by the twisted compactification of a 6d (2,0) A_2 theory on a Riemann sphere with an irregular puncture and a maximal regular puncture.

to the construction presented here. This brings into play the T -type operations, in addition to the S -type operations. In these classes of dualities, there will be additional constraints on the S -type operations (in gauging a certain flavor symmetry) coming from the parity anomaly.

2 $\mathcal{N} = 4$ mirror symmetry and linear quivers: generalities

In this section, we review some of the important basic concepts and computational tools for three dimensional gauge theories with eight real supercharges, which will be useful in the rest of the paper. The reader familiar with 3d $\mathcal{N} = 4$ physics can skip to section 3.

2.1 Supermultiplets and Lagrangian description

Supersymmetry and supermultiplets. $\mathcal{N} = 4$ supersymmetry in three dimensions has 8 real supercharges. We will work in terms of complex supercharges $Q_{\alpha AA'}$ which are doublets of $\text{Spin}(2, 1) \sim \text{SL}(2, \mathbb{R})$ (indexed by $\alpha = 1, 2$) and transform as $(2, 2)$ under the R-symmetry group, $\text{SU}(2)_H \times \text{SU}(2)_C$ (indexed by $A = 1, 2$ and $A' = 1, 2$ respectively). The complex supercharges on $\mathbb{R}^{1,2}$ (i.e. with signature $(-, +, +)$) generate the following supersymmetry algebra:

$$\{Q_{\alpha AA'}, Q_{\beta BB'}\} = (\gamma_{\mu} C)_{\alpha\beta} P^{\mu} \epsilon_{AB} \epsilon_{A'B'}, \tag{2.1}$$

where $\gamma_{\mu} = (\gamma_0, \gamma_1, \gamma_2) = (i\tau_3, \tau_1, \tau_2)$ (τ_i being the standard Pauli matrices), and the charge conjugation matrix $C = \tau_2$. The complex supercharges obey the reality condition $Q_{\alpha AA'}^{\dagger} = (\tau_1)_{\alpha}^{\beta} \epsilon^{AB} \epsilon^{A'B'} Q_{\beta BB'}$.

A Lagrangian theory with $\mathcal{N} = 4$ supersymmetry consists of a vector multiplet in the adjoint representation of a gauge group G , and hypermultiplets in a given quaternionic representation of G . The field content of the vector multiplet and the hypermultiplet can be obtained from dimensional reduction of the 4d $\mathcal{N} = 2$ vector multiplet and hypermultiplet respectively, and is given by the second column of table 3.⁵ The third column of table 3 lists the representations of the $\text{SU}(2)_H \times \text{SU}(2)_C$ R-symmetry in which the constituent fields transform. Note that the supermultiplets are not symmetric with respect to the $\text{SU}(2)_H$ and the $\text{SU}(2)_C$ representations, and this allows one to define corresponding “twisted” multiplets, i.e. multiplets where the representations of the two $\text{SU}(2)$ s are exchanged. In addition, the theory has a global symmetry group $G_H \times G_C$, that we will describe below.

In this paper, we will only consider theories with unitary (or special unitary) gauge groups with matter in a given representation \mathcal{R} of the gauge and global symmetries. For a given theory, the field content is most conveniently represented by a 3d $\mathcal{N} = 4$ quiver diagram — the conventions are explained in terms of an illustrative example in figure 2.

⁵A 3d gauge field can be dualized to a circle-valued scalar only for an Abelian gauge group. But a non-Abelian gauge group is Higgsed to at most an Abelian subgroup, at a generic point on the moduli space. Therefore, the counting can be carried over to describe the low energy theory.

Supermultiplets	Constituent Fields	$SU(2)_H \times SU(2)_C$
Vector	Bosons (σ, Φ, γ)	$(1, 3 \oplus 1)$
	Fermions $(\lambda_{AA'})$	$(2, 2)$
Hyper	Bosons $(\phi, \tilde{\phi}^\dagger)$	$(2, 1)$
	Fermions $(\psi, \tilde{\psi}^\dagger)$	$(1, 2)$

Table 3. The field content of three dimensional $\mathcal{N} = 4$ vector multiplet and hypermultiplet, along with the representations of R-symmetry in which they transform. Note that for the vector multiplet bosons, σ is a real non-compact scalar, Φ is a complex scalar, and γ is a real compact scalar dual to the 3d gauge field. For the hypermultiplet bosons, ϕ and $\tilde{\phi}$ are both complex scalars.

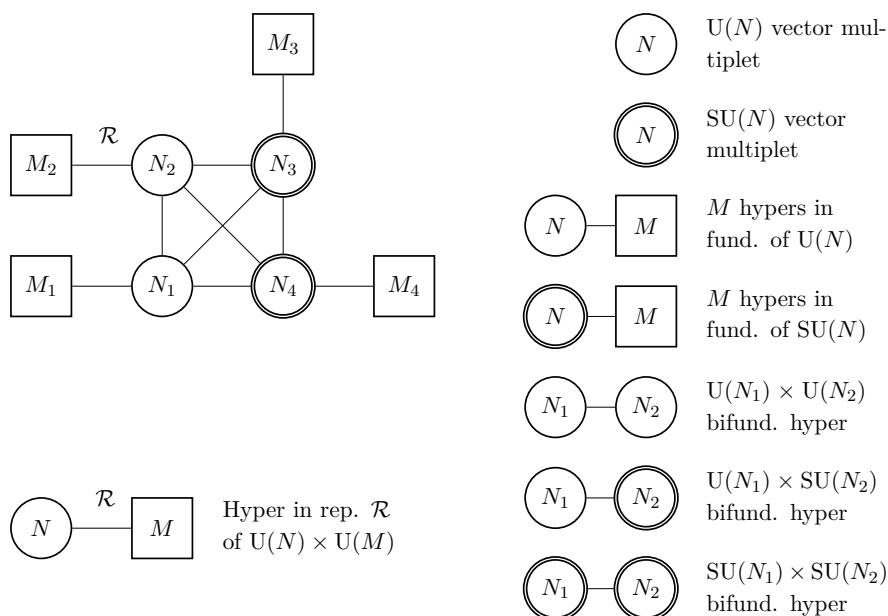

Figure 2. L.h.s.: a quiver diagram representing the field content of a 3d $\mathcal{N} = 4$ theory with gauge group $G = U(N_1) \times U(N_2) \times SU(N_3) \times SU(N_4)$, and fundamental/bifundamental matter. The various conventions are listed on the r.h.s. In a quiver diagram, we will refer to the circles as gauge nodes and the boxes as flavor nodes.

Lagrangian description. The action for the $\mathcal{N} = 4$ supersymmetric gauge theories is most conveniently presented in the 3d $\mathcal{N} = 2$ superspace language (see [42] for a recent review). An $\mathcal{N} = 4$ vector multiplet consists of one $\mathcal{N} = 2$ vector multiplet V and one $\mathcal{N} = 2$ chiral multiplet Φ in the adjoint of the gauge group. The action for an $\mathcal{N} = 4$ quiver gauge theory on $\mathbb{R}^{1,2}$ consists of the following terms [5, 33]:

- A Super-Yang-Mills term for the gauge group G :

$$S_{\text{SYM}}[V, \Phi] = \frac{1}{g_{\text{YM}}^2} \int d^3x d^2\theta d^2\tilde{\theta} \text{Tr} \left(-\frac{1}{4} \Sigma^2 - \Phi^\dagger e^{2V} \Phi \right), \quad (2.2)$$

where “Tr” is an invariant inner product on the Lie algebra of G , V is an $\mathcal{N} = 2$ vector multiplet and Φ is an $\mathcal{N} = 2$ adjoint chiral multiplet inside the $\mathcal{N} = 4$ vector

multiplet, while Σ is an $\mathcal{N} = 2$ multiplet (often called a linear multiplet), which includes the field strength of the gauge field in V . In terms of V , the superfield Σ is defined as:

$$\begin{aligned}\Sigma &= -\frac{i}{2}\epsilon^{\alpha\beta}\tilde{D}_\alpha D_\beta V(x^\mu, \theta_\alpha, \tilde{\theta}_\alpha), \\ D_\alpha &= \frac{\partial}{\partial\theta^\alpha} + i\gamma_{\alpha\beta}^\mu\tilde{\theta}^\beta\partial_\mu, \\ \tilde{D}_\alpha &= -\frac{\partial}{\partial\tilde{\theta}^\alpha} - i\theta^\beta\gamma_{\beta\alpha}^\mu\partial_\mu.\end{aligned}\tag{2.3}$$

- Kinetic terms and minimal gauge couplings for the hypermultiplets transforming in a representation \mathcal{R} of G :

$$S_{\text{matter}}[\phi, \tilde{\phi}, V] = \int d^3x d^2\theta d^2\tilde{\theta} \text{Tr}\left(\phi_i^\dagger e^{2V} \phi^i + \tilde{\phi}_i^\dagger e^{(-2V)} \tilde{\phi}^i\right)\tag{2.4}$$

where $\phi_i, \tilde{\phi}_i$ are $\mathcal{N} = 2$ chiral multiplets constituting a $\mathcal{N} = 4$ hypermultiplet with i being the global symmetry index.

- A holomorphic superpotential term for the $\mathcal{N} = 2$ chiral multiplets, which preserves $\mathcal{N} = 4$ supersymmetry.

$$S_{\text{sup}}[\phi, \tilde{\phi}, \Phi] = i\sqrt{2} \int d^3x d^2\theta \text{Tr}\left(\tilde{\phi}_i \Phi \phi^i\right) + h.c..\tag{2.5}$$

In addition, there are two possible $\mathcal{N} = 4$ -preserving deformations of the theory, which correspond to turning on mass terms for the hypermultiplets and Fayet-Iliopoulos (FI) terms for the $U(1)$ factors in the gauge group G .

- The hypermultiplet masses transform as triplets under $SU(2)_C$ and can be interpreted as the scalar components of a background $\mathcal{N} = 4$ vector multiplet associated with the Cartan subalgebra of the global symmetry group G_H . They couple to the flavor symmetry current in the standard way:

$$\begin{aligned}S_{\text{mass}}[\phi, \tilde{\phi}, V_m, \Phi_m] &= \int d^3x d^2\theta d^2\tilde{\theta} \text{Tr}\left(\phi_i^\dagger e^{2V_m^{ij}} \phi_j + \tilde{\phi}_i^\dagger e^{(-2V_m^{ij})} \tilde{\phi}_j\right) \\ &+ i\sqrt{2} \int d^3x d^2\theta \text{Tr}\left(\tilde{\phi}_i \Phi_m^{ij} \phi_j\right) + h.c.\end{aligned}\tag{2.6}$$

where $V_m^{ij} = V_m^a T_a^{ij}$ and $\Phi_m^{ij} = \Phi_m^a T_a^{ij}$ are respectively the $\mathcal{N} = 2$ vector and chiral multiplet which make up the $\mathcal{N} = 4$ background vector multiplet, with T_a^{ij} being a Cartan generator of the Lie algebra of G_H . The Tr is an invariant inner product on the Lie algebra of the gauge group G , as before.

- The FI parameters transform as triplets under $SU(2)_H$ and can be thought of as the scalar components of a *twisted* $\mathcal{N} = 4$ background vector multiplet associated with

the Cartan subalgebra of the global symmetry group G_C . They couple to the 3d topological currents for the $U(1)$ factors in the gauge group G by a BF term:

$$S_{\text{FI}}[V, \Phi, \hat{V}_{\text{FI}}, \hat{\Phi}_{\text{FI}}] = \int d^3x d^2\theta d^2\tilde{\theta} \text{Tr} \Sigma \hat{V}_{\text{FI}} + \int d^3x d^2\theta \text{Tr} \Phi \hat{\Phi}_{\text{FI}} + h.c. \quad (2.7)$$

where $\hat{V}_{\text{FI}}, \hat{\Phi}_{\text{FI}}$ denote the twisted $\mathcal{N} = 2$ vector and chiral multiplet that constitute an $\mathcal{N} = 4$ twisted vector multiplet.

The complete 3d $\mathcal{N} = 4$ action is a sum of the terms listed above:

$$S_{\mathcal{N}=4}[V, \Phi, \phi, \tilde{\phi}, V_m, \Phi_m, \hat{V}_{\text{FI}}, \hat{\Phi}_{\text{FI}}] = S_{\text{SYM}}[V, \Phi] + S_{\text{matter}}[\phi, \tilde{\phi}, V] + S_{\text{sup}}[\phi, \tilde{\phi}, \Phi] \\ + S_{\text{mass}}[\phi, \tilde{\phi}, V_m, \Phi_m] + S_{\text{FI}}[V, \Phi, \hat{V}_{\text{FI}}, \hat{\Phi}_{\text{FI}}]. \quad (2.8)$$

2.2 IR physics of 3d $\mathcal{N} = 4$ theories and mirror symmetry

Moduli spaces and LEET. A 3d $\mathcal{N} = 4$ theory has a dimensionful gauge coupling constant — the theory is asymptotically free in the UV and generically flows to a strongly-coupled interacting SCFT in the deep IR. The moduli space of vacua of these theories is a hyperkähler manifold with certain distinguished branches, which we will describe momentarily. The low energy effective theory (LEET) around any point on the moduli space gives the physics at the associated energy scale. In particular, the low energy theory at a generic smooth point on the moduli space is a free theory, while LEETs living on the singular loci of the moduli space can involve interesting SCFTs.

The moduli space of vacua has the following distinguished branches:

- **Higgs branch:** the Higgs branch \mathcal{M}_H corresponds to the branch of the moduli space where all hypermultiplet scalars have non-zero vacuum expectation value (vev), all the adjoint scalars have zero vev, and generically, the gauge group is completely Higgsed. It is a hyperkähler manifold and additionally admits a realization as a hyperkähler quotient. The quaternionic dimension of the manifold is given in terms of the dimensions of the gauge group and matter representation \mathcal{R} (of the gauge group and the global symmetry group G_H) by the following formula:

$$\dim \mathcal{M}_H = \dim_{\mathbb{C}}(\mathcal{R}) - \dim_{\mathbb{R}}(G). \quad (2.9)$$

The hyperkähler metric on the Higgs branch is protected against quantum corrections by supersymmetry. There is a natural action of $SU(2)_H \times G_H$ on the Higgs branch, where G_H is a manifest symmetry of the Lagrangian and commutes with the R-symmetry.

Viewed as an algebraic variety in a chosen complex structure, the associated chiral ring of holomorphic functions is generated by the expectation values of half-BPS local operators, which transform in irreps of $SU(2)_H \times G_H$ (and are singlets under $SU(2)_C$). These are built out of gauge-invariant polynomials of the hypermultiplet scalars.

- **Coulomb branch:** the Coulomb branch \mathcal{M}_C corresponds to the branch of the moduli space where the triplet of real adjoint scalars have non-zero vev, all hypermultiplet

scalars have zero vev, and the gauge group G , at a generic point on the branch, is broken to its maximal torus. The resultant Abelian gauge fields can be dualized to scalar fields, which together with the adjoint scalars give a hyperkähler manifold (but not necessarily a hyperkähler quotient). The hyperkähler metric on the manifold is *not* protected against quantum corrections, and the full quantum corrected metric can be directly computed only for very special cases. The quaternionic dimension of the manifold is:

$$\dim \mathcal{M}_G = \text{rank}(G). \tag{2.10}$$

There is a natural action of $SU(2)_C \times G_C$ on the Coulomb branch, where G_C is a global symmetry which commutes with the R-symmetry. In the UV, the manifest form of this global symmetry is $G_C = U(1)^k$, where k is the number of $U(1)$ factors in the gauge group G , while in the IR, G_C can be enhanced to a nonabelian group with rank k .

An alternative and modern way to describe the Coulomb branch is given in terms of BPS monopole operators [43, 44], which are local disorder operators very similar to the 't Hooft defects in four dimensions. In a 3d $\mathcal{N} = 4$ theory, a monopole operator is defined by introducing a Dirac monopole singularity, labelled by a cocharacter \mathbf{B} , for the gauge fields at an insertion point. Preserving half of the supersymmetry requires that one of the three real adjoint scalars should be singular at the insertion point. This implies introducing the following boundary condition in the 3d QFT at the insertion point \mathbf{x} :

$$A_{\pm} \sim \frac{B}{2}(\pm 1 - \cos \theta) d\phi, \quad \sigma \sim \frac{B}{2r}, \tag{2.11}$$

where (r, θ, ϕ) are spherical coordinates with \mathbf{x} as origin, A_{\pm} are the gauge fields on the northern/southern patches of the S^2 with \mathbf{x} as the center, and σ is a real adjoint scalar. The remaining two real scalar fields, combined into a single complex scalar Φ , are regular and must transform in the adjoint of the subgroup of G left unbroken by the monopole singularity. A monopole operator with $\Phi = 0$ is referred to as a “bare monopole operator” while those with $\Phi \neq 0$ is referred to as a “dressed monopole operator”. The monopole operators transform in irreps of $SU(2)_C \times G_C$ and are singlets under $SU(2)_H$.

In a chosen complex structure, the Coulomb branch can be viewed as an algebraic variety and the associated chiral ring of holomorphic functions is generated by the expectation values of the bare and dressed monopole operators described above. The choice of the complex structure, in particular, determines which of the real scalars is picked to be singular at the insertion point.

- **Mixed branches:** a mixed branch \mathcal{M}_M corresponds to a branch of the moduli space, where some of the hypermultiplet scalars as well as some of the adjoint scalars have non-zero vevs. The Higgsing of the gauge group on a given mixed branch depends on the precise scalar vevs turned on.

Good, bad, and ugly classification. A 3d $\mathcal{N} = 4$ SCFT has an $\text{Spin}(4)_{\text{IR}}$ R-symmetry. Generally speaking, the IR R-symmetry may not coincide with the $\text{SU}(2)_H \times \text{SU}(2)_C$ R-symmetry manifest in the UV Lagrangian. Assuming that $\text{Spin}(4)_{\text{IR}} \cong \text{SU}(2)_H \times \text{SU}(2)_C$, one can check [27] whether the various 1/2-BPS chiral primary operators of the SCFT satisfy the unitarity bound $\Delta \geq \frac{1}{2}$, where Δ is the conformal dimension of the operator in the IR. The Higgs branch chiral operators, which are built out of hypermultiplet scalars, trivially satisfy the bound. The Coulomb branch monopole operators, however, receive non-trivial corrections to their conformal dimension. For a theory with gauge group G , Higgs branch global symmetry G_H , and hypermultiplets transforming in a representation \mathcal{R} of $G \times G_H$, the conformal dimension of a monopole operator is given as [45, 46]:

$$\Delta(B) = q_R = - \sum_{\alpha \in \Delta^+} |\alpha(B)| + \frac{1}{2} \sum_{\rho \in \mathcal{R}} |\rho(B)|, \tag{2.12}$$

where $B \in \Lambda_{\text{cochar}}(G)$ labels the monopole operator, q_R is the charge of the monopole operator under the $\text{U}(1)_R$ R-symmetry of the $\mathcal{N} = 2$ subalgebra that it preserves, α is a positive root of the Lie algebra of G , and ρ is a weight of the $G \times G_H$ Lie algebra in the representation \mathcal{R} .

Consistency with unitarity leads to the following classification of 3d $\mathcal{N} = 4$ theories:

- **Good theory:** a given theory is good if $\Delta(B) > \frac{1}{2}$ for all $B \in \Lambda_{\text{cochar}}$. For such a theory, the most singular locus (i.e. singular locus of highest codimension) on the Coulomb branch is a point where the Coulomb and the Higgs branches intersect. The local geometry around this point is that of a conical variety and represents the moduli space of an $\mathcal{N} = 4$ SCFT for which $\text{Spin}(4)_{\text{IR}} \cong \text{SU}(2)_H \times \text{SU}(2)_C$. In the deep IR, the good theory flows to this SCFT.
- **Ugly theory:** a given theory is ugly if there exists at least one monopole operator for which $\Delta(B) = \frac{1}{2}$, but none with $\Delta(B) < \frac{1}{2}$. The most singular locus on the Coulomb branch is generically not a point. However, the local geometry around a generic point in the most singular locus is a product of some flat directions and a conical singularity, such that the former represents the moduli space of certain free twisted hypermultiplets, while the latter represents the moduli space of an $\mathcal{N} = 4$ SCFT for which $\text{Spin}(4)_{\text{IR}} \cong \text{SU}(2)_H \times \text{SU}(2)_C$. In the deep IR, the ugly theory therefore flows to an SCFT along with some free decoupled twisted hypermultiplets.
- **Bad theory:** a given theory is bad if there exists at least one unitarity violating monopole operator, i.e. for which $\Delta(B) < \frac{1}{2}$. Similar to ugly theories, the most singular locus on the Coulomb branch is not a point, and the local geometry around a generic point in this singular locus is a product of some flat directions and a conical singularity, with the former representing the moduli space of certain free twisted hypermultiplets. However, the conical singularity represents the moduli space of an $\mathcal{N} = 4$ SCFT for which $\text{Spin}(4)_{\text{IR}}$ does not coincide with the UV R-symmetry of the original theory, and is realized as an embedding inside the product of the UV R-symmetry and certain accidental flavor symmetry that appear in the IR [47–49].

Three dimensional mirror symmetry. An IR duality implies that a set of theories with different UV Lagrangians flow to the same IR SCFT. Mirror symmetry is a special case of an IR duality in three dimensions with the following properties:

- Given a pair of dual theories X and Y , mirror symmetry exchanges the Coulomb and the Higgs branches in the deep IR, i.e. as $g_{YM}^2 \rightarrow \infty$:

$$\mathcal{M}_C^{(X)} = \mathcal{M}_H^{(Y)}, \quad \mathcal{M}_H^{(X)} = \mathcal{M}_C^{(Y)}. \tag{2.13}$$

- The duality exchanges $SU(2)_C$ and $SU(2)_H$, and therefore exchanges background vector and twisted vector multiplets. This implies that hypermultiplet masses and FI parameters are exchanged under mirror symmetry.

Mirror symmetry relates observables in theory X with observables in theory Y , and the precise map is referred to as the “mirror map”. The simplest mirror map is the one which relates hypermultiplet masses on one side of the duality with FI parameters on the other (or vice-versa).

2.3 Checking mirror symmetry using RG flow invariant observables

Localization techniques [32, 50] can be used to compute exact expressions for various RG flow-invariant supersymmetric observables in a theory using the UV Lagrangian. A non-trivial check of an IR duality is to show that such supersymmetric observables for a given pair of dual theories agree. In this subsection, we present a brief review of a supersymmetric observable — the partition function of a 3d $\mathcal{N} = 4$ theory on a round three sphere, which will be one of the main tools of analysis in this paper. Consider an $\mathcal{N} = 4$ quiver gauge theory with gauge group G and global symmetry group G_H , such that the matter hypermultiplets transform in a representation \mathcal{R} of $G \times G_H$. We turn on background vector multiplets in the Cartan subalgebra of the global symmetry group G_H (hypermultiplet masses) as well as twisted background vector multiplets in the Cartan subalgebra of the topological symmetry group G_C (FI parameters). However, instead of the full triplet, we can only turn on a single real parameter in each case to preserve supersymmetry. In addition, one can turn on various supersymmetric defects in the theory. For a generic 3d $\mathcal{N} = 2$ theory, one can also turn on Chern-Simons interaction for the gauge group. In this paper, we will focus exclusively on $\mathcal{N} = 4$ theories, for which we set the Chern-Simons level $\kappa = 0$.

The rules for writing down the S^3 partition function for a generic 3d $\mathcal{N} = 4$ theory [32, 33] may be summarized as follows. Localization on S^3 ensures that the partition function can be written as a matrix integral in terms of a single real scalar s which lives in the Cartan of the gauge group, where s is the zero-mode associated with the real adjoint scalar that sits inside a 3d $\mathcal{N} = 2$ vector multiplet (which in turn sits inside a 3d $\mathcal{N} = 4$ vector multiplet). The partition function is a function of the real masses \mathbf{m} and real FI parameters $\boldsymbol{\eta}$, which should be thought of as real adjoint scalars inside the respective background $\mathcal{N} = 2$ vector multiplets (which in turn sits inside a 3d $\mathcal{N} = 4$ vector multiplet). In presence of defects, the partition function will also depend on some additional data \mathcal{D} . For example, Wilson

line defects, wrapping a great circle on S^3 , will be labelled by a representation \mathcal{R}_W of the gauge group.

Since S^3 does not have any instantons (unlike the case of S^4), the partition function may be written as a matrix integral where the integrand is built out of classical (FI and Chern-Simons) and one-loop contributions, as well possible supersymmetric defects:

$$\begin{aligned}
 Z(\mathbf{m}; \boldsymbol{\eta}; \mathbf{k}; \mathcal{D}) &= \int [d\mathbf{s}] Z_{\text{int}}(\mathbf{s}, \mathbf{m}, \boldsymbol{\eta}, \mathcal{D}) \\
 &= \int [d\mathbf{s}] Z_{\text{CS}}(\mathbf{s}, \mathbf{k}) Z_{\text{FI}}(\mathbf{s}, \boldsymbol{\eta}) Z_{\text{defect}}(\mathbf{s}, \mathcal{D}) Z_{1\text{-loop}}^{\text{vector}}(\mathbf{s}) Z_{1\text{-loop}}^{\text{hyper}}(\mathbf{s}, \mathbf{m}), \quad (2.14)
 \end{aligned}$$

where $[d\mathbf{s}] = \frac{d^k \mathbf{s}}{|W(G)|}$, and $|W(G)|$ is the order of the Weyl group of G . The individual terms in the integrand on the r.h.s. are given as follows.

- The Chern-Simons interactions for various factors in the gauge group gives the classical contribution:

$$Z_{\text{CS}}(\mathbf{s}, \mathbf{k}) = \prod_{\gamma} e^{2\pi i k_{\gamma} \text{Tr}(\mathbf{s}^{\gamma})^2}, \quad (2.15)$$

where γ runs over all the factors in the gauge group.

- The l U(1) factors in the gauge group gives the following classical contribution

$$Z_{\text{FI}}(\mathbf{s}, \boldsymbol{\eta}) = \prod_{\gamma=1}^l e^{2\pi i \eta_{\gamma} \text{Tr}(\mathbf{s}^{\gamma})}, \quad (2.16)$$

where γ runs over the l gauge nodes with a U(1) factor and η_{γ} is the associated FI parameter.

- The contribution of a Wilson line defect in a representation \mathcal{R}_W of the gauge group, is given as

$$Z_{\text{defect}}(\mathbf{s}, \mathcal{D}) := Z_{\text{Wilson}}(\mathbf{s}, \mathcal{R}_W) = \frac{1}{\dim(\mathcal{R}_W)} \text{Tr}_{\mathcal{R}_W} \left(e^{2\pi \mathbf{s}} \right). \quad (2.17)$$

- The $\mathcal{N} = 4$ vector multiplet contributes a one-loop term:

$$Z_{1\text{-loop}}^{\text{vector}}(\mathbf{s}) = \prod_{\alpha} \sinh \pi \alpha(\mathbf{s}), \quad (2.18)$$

where the product extends over the roots of the Lie algebra of G . In fact, this is precisely the contribution of an $\mathcal{N} = 2$ vector multiplet since contribution of the adjoint chiral which is part of the $\mathcal{N} = 4$ vector multiplet is trivial [33].⁶

⁶Strictly speaking, the vector one-loop contribution contains a factor of the Vandermonde determinant $\prod_{\alpha} \alpha(\mathbf{s})$ in the denominator. However, this factor exactly cancels with another factor of Vandermonde determinant coming from the measure of the integration over the Cartan of the gauge group. We will also ignore certain factors of 2 that appear in the 1-loop contributions for the vector multiplet and the hypermultiplet.

- The one-loop contribution from $\mathcal{N} = 4$ hypermultiplets transforming in a representation \mathcal{R} of $G \times G_H$:

$$Z_{1\text{-loop}}^{\text{hyper}}(\mathbf{s}, \mathbf{m}) = \prod_{\rho(\mathcal{R})} \frac{1}{\cosh \pi \rho(\mathbf{s}, \mathbf{m})}, \tag{2.19}$$

where the product extends over the weights of the representation \mathcal{R} .

Consider a pair of theories X and Y which are mirror dual to each other. Assuming no line defects and Chern-Simons terms are turned on, the IR duality implies that the partition functions of the theories⁷ are related as:

$$Z^{(X)}(\mathbf{m}; \boldsymbol{\eta}) = e^{2\pi i a^{kl} m_k \eta_l} Z^{(Y)}(\mathbf{m}'(\boldsymbol{\eta}); \boldsymbol{\eta}'(\mathbf{m})), \tag{2.20}$$

where $(\mathbf{m}, \boldsymbol{\eta}), (\mathbf{m}', \boldsymbol{\eta}')$ are the masses and FI parameters for X and Y respectively. The mass parameters \mathbf{m}' of Y are linear functions of the FI parameters $\boldsymbol{\eta}$ of X , while FI parameters $\boldsymbol{\eta}'$ of Y are linear functions of the FI parameters \mathbf{m} of X , as expected under mirror symmetry. The overall phase factor $e^{2\pi i a^{kl} m_k \eta_l}$, whose exponents are linear in \mathbf{m} and $\boldsymbol{\eta}$ with integer a^{kl} , correspond to three-dimensional contact terms as discussed in [51].

The localization computation relies on the assumption that the IR conformal dimensions of fields can be read off from their transformation properties under the R-symmetry visible in the UV Lagrangian, which in turn implies that the UV R-symmetry is assumed to be the same as the R-symmetry of the IR SCFT. In terms of the classification of 3d $\mathcal{N} = 4$ theories presented in section 2.2, the formula for the sphere partition function presented in (2.14) is only valid for the good and ugly theories, and not for the bad theories. In fact, one can show that the condition $-\Delta(B) \geq \frac{1}{2}$ for all cocharacters B — for a good/ugly theory derived by Gaiotto and Witten [27] is equivalent to the condition for the above partition function to be absolutely convergent in the absence of defects. This can be seen in the following fashion [52]. First note that the integrand is regular at all finite real values of \mathbf{s} (the poles coming from hyperbolic cosine functions are all located on the imaginary axis), and therefore any divergence in the integral must arise from very large values of the integration variable \mathbf{s} . Consider a ray in the Cartan subalgebra of G in the direction specified by a cocharacter B , and let $r \in \mathbb{R}_+$ be a coordinate along the ray. The subset of such rays is dense in the set of all rays in the Cartan subalgebra of G . Now, at large values of the coordinate r , the integrand behaves as $e^{-rq(B)}$, where $q(B) \in \mathbb{Z}$ is

$$q(B) = - \sum_{\alpha \in \Delta^+} |\alpha(B)| + \frac{1}{2} \sum_{\rho \in \mathcal{R}} |\rho(B)|. \tag{2.21}$$

The Gaiotto-Witten condition $\Delta(B) \geq \frac{1}{2}$ for good/ugly theories guarantees that $q(B) \geq 1$ for all cocharacters B , which implies that the integrand falls off sufficiently fast at large \mathbf{s} along any ray in the Cartan subalgebra and therefore gives a finite integral. For a bad theory, one can have $q(B) = 0$ for some cocharacter(s) B which will lead to a divergent integral.

In this paper, we will use another RG-invariant supersymmetric observable, i.e. superconformal index on $S^2 \times S^1$, which we review in section B.

⁷We will denote the partition function of a quiver Q with real mass parameters \mathbf{x} and FI parameters \mathbf{y} as $Z^{(Q)}(\mathbf{x}; \mathbf{y})$.

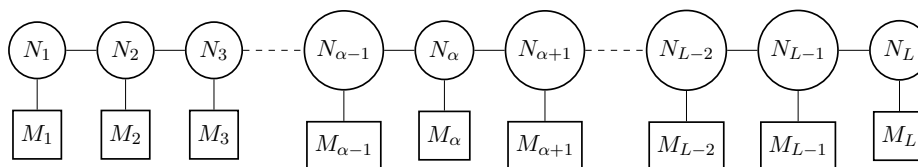

Figure 3. A generic linear quiver with L gauge nodes.

	0	1	2	3	4	5	6	7	8	9
NS5	x	x	x	·	·	·	·	x	x	x
D5	x	x	x	·	x	x	x	·	·	·
D3	x	x	x	x	·	·	·	·	·	·

Table 4. Basic Type IIB brane construction.

2.4 Mirror symmetry as S-duality in type IIB construction: linear quivers

In this section, we present a brief review of a very special class of 3d $\mathcal{N} = 4$ quiver gauge theory — linear quivers with unitary gauge groups. A generic example with L gauge nodes is shown in figure 3. For a more detailed account on the physics and geometry of linear quivers, we refer the reader to the papers [26, 27].

The linear quivers have a very simple realization in terms of a Type IIB brane construction of the Hanany-Witten type [24]. A large class of 3d $\mathcal{N} = 4$ Lagrangian theories can be obtained by considering D3 branes extending along a compact direction L , with 1/2-BPS boundary conditions at the two ends [27]. For linear quivers, the set-up involves D3, D5 and NS5 branes, with their respective world-volumes specified in table 4. The gauge theory data can be read off from a configuration where all D3 branes end on NS5 branes using the following set of rules:

- D3-D3 open strings in the γ -th NS5 chamber containing N_γ D3 branes give a $U(N_\gamma)$ vector multiplet.
- D3-D5 open strings in the γ -th NS5 chamber, containing M_γ D5 branes, give M_γ hypermultiplets in the fundamental representation of $U(N_\gamma)$.
- D3-D3 open strings running between the γ -th and the $\gamma + 1$ -th NS5 chambers give hypermultiplets in the bifundamental of $U(N_\gamma) \times U(N_{\gamma+1})$.
- The triplet of mass parameters m_β^Z , with $\beta = 1, \dots, \sum_{\gamma=1}^L M_\gamma$, correspond to the position of the D5 branes in $\mathbb{R}_{7,8,9}^3$, while for the triplet of FI parameters $\eta_\gamma^Y = t_\gamma^Y - t_{\gamma+1}^Y$, with $\gamma = 1, \dots, L$, the parameters t^Y correspond to the position of the NS5 branes in $\mathbb{R}_{4,5,6}^3$. Given the translational symmetry on \mathbb{R}^3 , both sets of moduli should be counted up to an overall shift.

Figure 4 gives an illustrative example of how one can read off the gauge theory content from the brane set up. Mirror symmetry in three dimensions can be understood

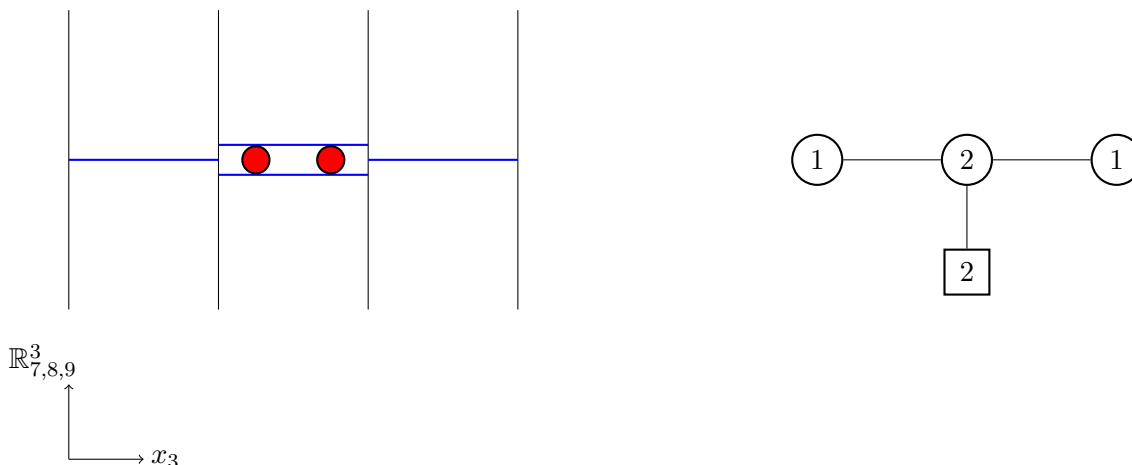

Figure 4. The figure on the left shows the Type IIB brane construction for the linear quiver on the right. The red nodes represent D5 branes, the horizontal blue lines are D3 branes, and the vertical black lines represent NS5 branes.

as an S-duality of the above brane construction, followed by a rotation $R : \mathbf{x}^{7,8,9} \rightarrow -\mathbf{x}^{4,5,6}, \mathbf{x}^{4,5,6} \rightarrow \mathbf{x}^{7,8,9}$. NS5 and D5 branes are exchanged under S-duality, while D3 branes are self-dual. To read off the dual gauge theory from the rotated S-dual brane system, one has to move to a configuration where the all D3 branes end on NS5 branes. This can be done by performing a series of Hanany-Witten moves, where NS5 and D5 branes are moved past each other along the compact direction x^3 . This generically results in creation/annihilation of D3 branes which are required to keep the *linking numbers* of the individual 5-branes invariant [24, 27]. The linking numbers of the 5-branes ($l_\gamma^{\text{NS5}}, l_\beta^{\text{D5}}$) in a generic brane configuration are given as:

$$l_\gamma^{\text{NS5}} = n_{\text{left}}(\text{D5}) - \tilde{n}_{\text{left}}(\text{D3}) + \tilde{n}_{\text{right}}(\text{D3}), \quad \gamma = 1, \dots, L + 1, \quad (2.22)$$

$$l_\beta^{\text{D5}} = n_{\text{left}}(\text{NS5}) - \tilde{n}_{\text{left}}(\text{D3}) + \tilde{n}_{\text{right}}(\text{D3}), \quad \beta = 1, \dots, L^\vee + 1, \quad (2.23)$$

where $L^\vee = \sum_{\gamma=1}^L M_\gamma - 1$, $n_{\text{left},\text{right}}(\text{D5/NS5})$ denotes the number of D5/NS5-branes to the left or right of the 5-brane in question, while $\tilde{n}_{\text{left},\text{right}}(\text{D3})$ denotes the number of D3 branes ending on the 5-brane from the left and the right respectively. The mirror dual of the generic quiver in figure 3 is then given by the linear quiver in figure 7, where the ranks of the gauge group factors and the flavor symmetry factors can be computed from

$$M_{\gamma'}^\vee = \sum_{\gamma=1}^{L+1} \delta_{\gamma'} l_\gamma^{\text{NS5}}, \quad \gamma' = 1, \dots, L^\vee, \quad (2.24)$$

$$N_{\beta+1}^\vee + N_{\beta-1}^\vee - 2N_\beta^\vee + M_\beta^\vee = l_{\beta+1}^{\text{D5}} - l_\beta^{\text{D5}}, \quad \beta = 1, \dots, L^\vee, \quad (2.25)$$

where the latter equation should be solved subject to the boundary conditions $M_0^\vee = M_{L^\vee+1}^\vee = 0$, and $N_0^\vee = N_{L^\vee+1}^\vee = 0$.

The S-duality followed by a rotation exchanges the positions of NS5 and D5 branes up to a sign, which explains the form of the mirror map in (2.26). As a concrete example,

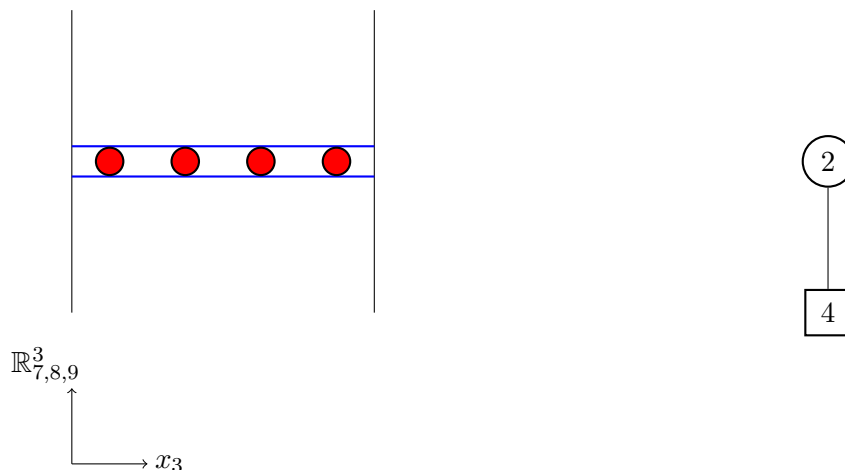

Figure 5. The figure on the left shows the Type IIB brane construction for the linear quiver on the right. The red nodes represent D5 branes, the horizontal blue lines are D3 branes, and the vertical black lines represent NS5 branes.

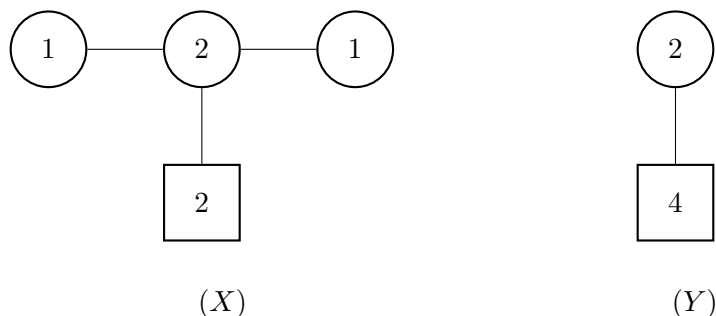

Figure 6. An example of a pair of linear quivers with unitary gauge groups which are 3d mirrors.

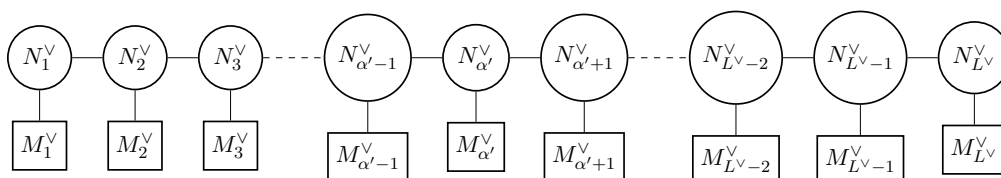

Figure 7. The linear quiver which is mirror dual to the generic linear quiver in figure 3. The total number of gauge nodes is L^V .

consider the linear quiver and its Type IIB realization in figure 4. The rotated S-dual configuration, after appropriate Hanany-Witten moves, is shown in the l.h.s. of figure 5 and the corresponding 3d quiver is shown on the r.h.s. The latter is the mirror dual of the linear quiver in figure 4.

Note that we can easily generalize this Type IIB description to include affine \hat{A}_N quivers with unitary gauge groups. In this case, the compact direction x^3 wrapped by D3 branes is a circle.

We will now summarize a set of properties of linear quivers that will be useful in the rest of the paper:

- **Global symmetries:** the global symmetry on the Higgs branch of a linear quiver is $G_H = (\prod_{\gamma=1}^L U(M_\gamma))/U(1)$, while the global symmetry on the Coulomb branch manifest in the Lagrangian is $G_C = U(1)^L$. The Coulomb branch symmetry can be enhanced if one or more gauge nodes are balanced, i.e. $N_{\gamma-1} + N_{\gamma+1} + M_\gamma = 2N_\gamma$ for a balanced gauge node γ . For an array of n consecutive balanced nodes, the corresponding global symmetry is enhanced as $U(1)^n \rightarrow SU(n+1)$.
- **“Goodness”:** a linear quiver is a good theory in the Gaiotto-Witten classification if every gauge node in the quiver is individually good, i.e. $\Delta_\gamma = N_{\gamma-1} + N_{\gamma+1} + M_\gamma - 2N_\gamma \geq 0$, for $\gamma = 1, \dots, L$. Note that this is a special property of linear quivers, and a similar statement is not true for quivers of arbitrary shape.
- **Mirror symmetry:** the mirror dual of a good linear quiver is another good linear quiver. In addition, the mirror map between the masses and FI parameters is extremely simple. Let the FI parameters of the linear quiver in figure 3 be parametrized as $\eta_\gamma^Y = t_\gamma^Y - t_{\gamma+1}^Y$, with $\gamma = 1, \dots, L$ and $Y = 1, 2, 3$, and the hypermultiplet masses be $m_\beta^Z = \{\mathbf{m}^{Z\gamma}\} = \{\mathbf{m}^{Z1}, \dots, \mathbf{m}^{ZL}\}$, with $\beta = 1, \dots, L^\vee + 1$, $\gamma = 1, \dots, L$, and $Z = 1, 2, 3$. Recall that the mass parameters are triplets of $SU(2)_C$ (indexed by Z), and the FI parameters are triplets of $SU(2)_H$ (indexed by Y). The dual theory, where $SU(2)_C$ and $SU(2)_H$ are exchanged, is given by the linear quiver in figure 7, with the ranks of the gauge group and flavor symmetry group given in (2.24)–(2.25). The dual theory has mass parameters $m_{\beta'}^{\vee Y} = \{m_Y^{\vee\gamma'}\} = \{\mathbf{m}_Y^{\vee1}, \dots, \mathbf{m}_Y^{\vee L^\vee}\}$, with $\beta' = 1, \dots, L+1$, and FI parameters $\eta_{\gamma'}^{\vee Z} = t_{\gamma'}^{\vee Z} - t_{\gamma'+1}^{\vee Z}$, with $\gamma' = 1, \dots, L^\vee$. The mirror map in this case is simply given by:

$$m_{\beta'}^{\vee Y} = -t_{\beta'}^Y, \forall Y, \forall \beta' = 1, \dots, L+1, \quad t_{\beta'}^{\vee Z} = m_\beta^Z, \forall Z, \forall \beta = 1, \dots, L^\vee + 1. \quad (2.26)$$

- **Partition function and its dual:** as discussed in section 2.3, one can directly check mirror symmetry for a pair of theories using RG-invariant supersymmetric observables computed using localization. The partition function on round S^3 (where only a real deformation parameter is turned on instead of a triplet) of the quiver X is given as

$$\begin{aligned} Z^{(X)}(\mathbf{m}; \mathbf{t}) &= \int \prod_{\gamma=1}^L [d\mathbf{s}^\gamma] Z_{\text{int}}^{(X)}(\{\mathbf{s}^\gamma\}, \mathbf{m}, \mathbf{t}) \\ &= \int \prod_{\gamma=1}^L [d\mathbf{s}^\gamma] Z_{\text{FI}}^{(X)}(\{\mathbf{s}^\gamma\}, \mathbf{t}) Z_{1\text{-loop}}^{(X)}(\{\mathbf{s}^\gamma\}, \{\mathbf{m}^\gamma\}) \\ &= \int \prod_{\gamma=1}^L [d\mathbf{s}^\gamma] Z_{\text{FI}}^{(X)}(\{\mathbf{s}^\gamma\}, \mathbf{t}) \prod_{\gamma=1}^L Z_{1\text{-loop}}^{\text{vector}}(\mathbf{s}^\gamma) Z_{1\text{-loop}}^{\text{fund}}(\mathbf{s}^\gamma, \mathbf{m}^\gamma) \\ &\quad \times \prod_{\gamma=1}^{L-1} Z_{1\text{-loop}}^{\text{bif}}(\mathbf{s}^\gamma, \mathbf{s}^{\gamma+1}, 0). \end{aligned} \quad (2.27)$$

The classical and the 1-loop contributions to the integrand are given as

$$\begin{aligned}
 Z_{\text{FI}}^{(X)}(\{\mathbf{s}^\gamma\}, \mathbf{t}) &= \prod_{\gamma=1}^L e^{2\pi i \sum_{i_\gamma=1}^{N_\gamma} s_{i_\gamma}^\gamma (t_\gamma - t_{\gamma+1})}, \quad Z_{1\text{-loop}}^{\text{vector}}(\mathbf{s}^\gamma) = \prod_{i_\gamma \neq j_\gamma} \sinh \pi (s_{i_\gamma}^\gamma - s_{j_\gamma}^\gamma), \\
 Z_{1\text{-loop}}^{\text{fund}}(\mathbf{s}^\gamma, \mathbf{m}^\gamma) &= \frac{1}{\prod_{i_\gamma=1}^{N_\gamma} \prod_{l_\gamma=1}^{M_\gamma} \cosh \pi (s_{i_\gamma}^\gamma - m_{l_\gamma}^\gamma)}, \\
 Z_{1\text{-loop}}^{\text{bif}}(\mathbf{s}^\gamma, \mathbf{s}^{\gamma+1}, \mathbf{m}_\gamma^{\text{bif}}) &= \frac{1}{\prod_{i_\gamma=1}^{N_\gamma} \prod_{i_{\gamma+1}=1}^{N_{\gamma+1}} \cosh \pi (s_{i_\gamma}^\gamma - s_{i_{\gamma+1}}^{\gamma+1} - m_\gamma^{\text{bif}})}, \tag{2.28}
 \end{aligned}$$

where the fundamental masses and the bifundamental masses are labelled as \mathbf{m}^γ and $\mathbf{m}_\gamma^{\text{bif}}$ respectively. The partition function of the dual quiver Y is similarly given as

$$\begin{aligned}
 Z^{(Y)}(\mathbf{m}^\vee; \mathbf{t}^\vee) &= \int \prod_{\gamma'=1}^{L^\vee} [d\boldsymbol{\sigma}^{\gamma'}] Z_{\text{int}}^{(Y)}(\{\boldsymbol{\sigma}^{\gamma'}\}, \mathbf{m}^\vee, \mathbf{t}^\vee) \\
 &= \int \prod_{\gamma'=1}^{L^\vee} [d\boldsymbol{\sigma}^{\gamma'}] Z_{\text{FI}}^{(Y)}(\{\boldsymbol{\sigma}^{\gamma'}\}, \mathbf{t}^\vee) Z_{1\text{-loop}}^{(Y)}(\{\boldsymbol{\sigma}^{\gamma'}\}, \{\mathbf{m}^{\vee \gamma'}\}) \\
 &= \int \prod_{\gamma'=1}^{L^\vee} [d\boldsymbol{\sigma}^{\gamma'}] Z_{\text{FI}}^{(Y)}(\{\boldsymbol{\sigma}^{\gamma'}\}, \mathbf{t}^\vee) \prod_{\gamma'=1}^{L^\vee} Z_{1\text{-loop}}^{\text{vector}}(\boldsymbol{\sigma}^{\gamma'}) Z_{1\text{-loop}}^{\text{fund}}(\boldsymbol{\sigma}^{\gamma'}, \mathbf{m}^{\vee \gamma'}) \\
 &\quad \times \prod_{\gamma'=1}^{L^\vee-1} Z_{1\text{-loop}}^{\text{bif}}(\boldsymbol{\sigma}^{\gamma'}, \boldsymbol{\sigma}^{\gamma'+1}, 0), \tag{2.29}
 \end{aligned}$$

where the classical and the 1-loop contributions to the integrand are given as follows:

$$\begin{aligned}
 Z_{\text{FI}}^{(Y)}(\{\boldsymbol{\sigma}^{\gamma'}\}, \mathbf{t}^\vee) &= \prod_{\gamma'=1}^{L^\vee} e^{2\pi i \sum_{i_{\gamma'}=1}^{N_{\gamma'}^\vee} \sigma_{i_{\gamma'}}^{\gamma'} (t_{\gamma'}^\vee - t_{\gamma'+1}^\vee)}, \\
 Z_{1\text{-loop}}^{\text{vector}}(\boldsymbol{\sigma}^{\gamma'}) &= \prod_{i_{\gamma'} \neq j_{\gamma'}} \sinh \pi (\sigma_{i_{\gamma'}}^{\gamma'} - \sigma_{j_{\gamma'}}^{\gamma'}), \\
 Z_{1\text{-loop}}^{\text{fund}}(\boldsymbol{\sigma}^{\gamma'}, \mathbf{m}^{\vee \gamma'}) &= \frac{1}{\prod_{i_{\gamma'}=1}^{N_{\gamma'}^\vee} \prod_{l_{\gamma'}=1}^{M_{\gamma'}^\vee} \cosh \pi (\sigma_{i_{\gamma'}}^{\gamma'} - m_{l_{\gamma'}}^{\vee \gamma'})}, \\
 Z_{1\text{-loop}}^{\text{bif}}(\boldsymbol{\sigma}^{\gamma'}, \boldsymbol{\sigma}^{\gamma'+1}, m_{\text{bif}}^{\vee \gamma'}) &= \frac{1}{\prod_{i_{\gamma'}=1}^{N_{\gamma'}^\vee} \prod_{i_{\gamma'+1}=1}^{N_{\gamma'+1}^\vee} \cosh \pi (\sigma_{i_{\gamma'}}^{\gamma'} - \sigma_{i_{\gamma'+1}}^{\gamma'+1} - m_{\text{bif}}^{\vee \gamma'})}. \tag{2.30}
 \end{aligned}$$

Mirror symmetry implies that the partition functions of X and Y are related as

$$Z^{(X)}(\mathbf{m}; \mathbf{t}) = e^{2\pi i a^{kl} m_k t_l} Z^{(Y)}(-\mathbf{t}; \mathbf{m}), \tag{2.31}$$

where the overall phase factors can be interpreted as three-dimensional contact terms. Here a^{kl} is an $M \times (L+1)$ matrix with integer entries, $M = \sum_{\alpha=1}^L M_\alpha$ and L is the number of nodes in quiver A . The general proof of the above equality is non-trivial, and we refer the reader to [33] for details.

We would like to emphasize an important feature of this partition function equality. For quiver X , the integrand is manifestly invariant under a S_{M_γ} -transformation of the mass parameters \mathbf{m}^γ (this is the Weyl symmetry of the flavor group $U(M_\gamma)$), which in turn makes the partition function of X invariant under these transformations. However, for the dual theory Y , where \mathbf{m}^γ appear as FI parameters, the partition function is not manifestly invariant under these transformations. In fact, one can show that the matrix integral for (Y) , generically changes by some overall phase factor under these transformations. The contact term contribution also changes by a phase factor. It turns out that these two phase factors exactly cancel each other. There is an analogous argument for permutation of the parameters \mathbf{t} , which appear as mass parameters of Y , and FI parameters for X .

Finally, let us show the equality (2.31) explicitly for the simple example of the pair of theories in figure 6. The partition function of the quiver X is

$$Z^{(X)}(\mathbf{m}; \mathbf{t}) = \int \prod_{\alpha=1}^2 ds_\alpha \frac{d^2 s_0}{2!} \frac{e^{2\pi i s_1(t_1-t_2)} e^{2\pi i \sum_i s_0^i(t_2-t_3)} e^{2\pi i s_2(t_3-t_4)} \sinh^2 \pi(s_0^1 - s_0^2)}{\prod_{i=1}^2 \cosh \pi(s_1 - s_0^i) \prod_{a=1}^2 \cosh \pi(s_0^i - m_a) \cosh \pi(s_2 - s_0^i)}, \tag{2.32}$$

where m_1 and m_2 are the masses of the fundamental hypermultiplets in the middle node, and the FI parameters of the three gauge nodes are $\eta_1 = t_1 - t_2, \eta_0 = t_2 - t_3, \eta_2 = t_3 - t_4$.

Similarly, the partition function of the quiver Y is

$$Z^{(Y)}(\tilde{\mathbf{m}}; \tilde{\mathbf{t}}) = \int \frac{d^2 \sigma}{2!} \frac{\prod_{i=1}^2 e^{2\pi i \sigma^i(\tilde{t}_1 - \tilde{t}_2)} \sinh^2 \pi(\sigma^1 - \sigma^2)}{\prod_{i=1}^2 \prod_{a=1}^4 \cosh \pi(\sigma^i - \tilde{m}_a)}, \tag{2.33}$$

where $\tilde{m}_1, \tilde{m}_2, \tilde{m}_3, \tilde{m}_4$ are hypermultiplet masses, while the FI parameter of the gauge group is $\eta = \tilde{t}_1 - \tilde{t}_2$. Evaluating the two matrix integrals explicitly, one can check that

$$Z^{(X)}[\mathbf{m}; \mathbf{t}] = e^{2\pi i m_1(t_1+t_2)} e^{-2\pi i m_2(t_3+t_4)} Z^{(Y)}[-\mathbf{t}; \mathbf{m}]. \tag{2.34}$$

The expressions agree exactly (i.e. the phase factor vanishes) when one imposes the constraints $m_1 + m_2 = 0, t_1 + t_2 + t_3 + t_4 = 0$.

3 Generating mirrors from linear quiver pairs using S -type operations

In this section, we define the S -type operations on a generic 3d $\mathcal{N} = 4$ quiver gauge theory X in class \mathcal{U} , i.e. the Higgs branch global symmetry of X has a subgroup of the form $\prod_\gamma U(M_\gamma)$. We then discuss the field theory machinery for generating new pairs of mirror dual theories starting from a pair of linear quivers, in terms of the S^3 partition function.

In section 3.1, we discuss the four basic \mathcal{Q} -operations (defined in (1.5)–(1.6)) on X , and then define an elementary S -type operation in terms of these operations. We discuss the realization of these operations at the level of the $\mathcal{N} = 4$ quiver diagram as well as the S^3 partition function. In section 3.2, we discuss how quivers of arbitrary shapes can be constructed in steps by the action of elementary S -type operations starting from a linear quiver. In particular, we discuss the four distinct types of elementary S -type operations

separately. We give a partition function prescription for writing down the duals of these elementary S -type operations in section 3.3. Sections 3.2–3.3 therefore gives the complete partition function recipe for constructing a new pair of dual theories from the original dual pair of linear quivers. In section 3.4, we present a simple illustrative example involving a dual pair of Abelian quiver gauge theories that can be constructed following the recipe of section 3.2 and section 3.3. Another set of examples involving (affine) D -type quivers can be found in appendix A.

In appendix C, we discuss how the elementary S -type operations can be implemented in terms of the superconformal index on $S^2 \times S^1$. Analogous to the case of the partition function on S^3 , this leads to a natural prescription for the dual operations.

3.1 Elementary S -type and T -type operations on a generic quiver

Consider a quiver gauge theory X in class \mathcal{U} . We will assume that the theory X is good in the Gaiotto-Witten sense [27], which in turn implies that the round three sphere partition function of the theory is convergent [52], as discussed in section 2.3. Given the quiver X , one can describe the set of four basic \mathcal{Q} -operations in the concrete case of 3d $\mathcal{N} = 4$ quiver gauge theories as follows:

- **Gauging operation:** a *gauging operation* $G_{\mathcal{P}}^\alpha$ at a flavor node α of the theory X (shown schematically in figure 8) involves the following two steps:

1. Given a flavor node $U(M_\alpha)$, we split it into two flavor nodes, corresponding to a $U(r_\alpha) \times U(M_\alpha - r_\alpha)$ global symmetry. At the level of the Lagrangian, this simply implies identifying the $U(1)^{M_\alpha}$ background vector multiplets as $U(1)^{r_\alpha} \times U(1)^{M_\alpha - r_\alpha}$ background vector multiplets. In particular, this implies identifying the $U(1)^{M_\alpha}$ mass parameters \vec{m}^α with the $U(1)^{r_\alpha} \times U(1)^{M_\alpha - r_\alpha}$ mass parameters $(\vec{u}^\alpha, \vec{v}^\alpha)$. There is an S_{M_α} (permutation group of M_α objects) worth of freedom in this identification, and a specific choice is part of the data for this procedure. We will choose to parametrize this identification as:

$$\vec{m}^\alpha_{i_\alpha} = \mathcal{P}_{i_\alpha i} \vec{u}_i^\alpha + \mathcal{P}_{i_\alpha r_\alpha + j} \vec{v}_j^\alpha, \quad i_\alpha = 1, \dots, M_\alpha, \quad i = 1, \dots, r_\alpha, \quad j = 1, \dots, M_\alpha - r_\alpha, \quad (3.1)$$

where \mathcal{P} is a permutation matrix of order M_α . A choice of \mathcal{P} therefore encodes the additional data of how the $U(1)^{r_\alpha} \times U(1)^{M_\alpha - r_\alpha}$ background fields are chosen from the original $U(1)^{M_\alpha}$ ones. We will denote the theory deformed by the $U(r_\alpha) \times U(M_\alpha - r_\alpha)$ mass parameters as (X, \mathcal{P}) .

2. Given the theory (X, \mathcal{P}) , we promote the flavor symmetry node $U(r_\alpha)$ to a gauge node, as shown on the r.h.s. of figure 8, i.e. make the vector multiplets for $U(r_\alpha)$ dynamical, as well as turning on a background twisted vector multiplet for the $U(1)_J$ topological symmetry.

The operation can be implemented in terms of the S^3 partition function for the quiver X . Recall that preserving supersymmetry on S^3 permits turning on a single real mass

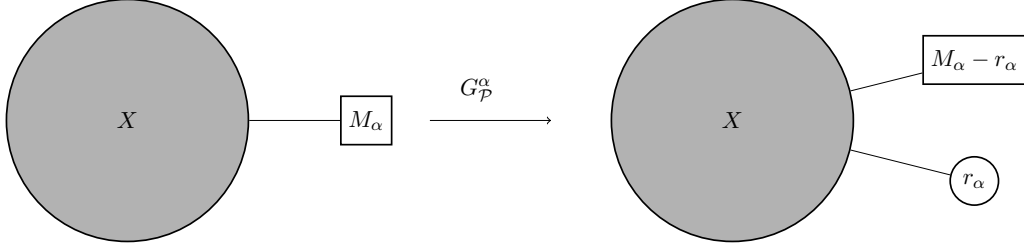

Figure 8. A gauging operation $G_{\mathcal{P}}^{\alpha}$ on a $U(M_{\alpha})$ subgroup of the global symmetry group of a generic quiver gauge theory (represented by the grey circle).

parameter as opposed to the triplet in the Cartan of G_H . The partition function of (X, \mathcal{P}) is given as

$$Z^{(X, \mathcal{P})}(\mathbf{u}^{\alpha}, \mathbf{v}^{\alpha}, \dots; \boldsymbol{\eta}) := Z^{(X)}(\mathbf{m}^{\alpha}(\mathcal{P}, \mathbf{u}^{\alpha}, \mathbf{v}^{\alpha}), \dots; \boldsymbol{\eta}), \quad (3.2)$$

where the \dots denote the mass parameters of theory X aside from \mathbf{m}^{α} , and $\boldsymbol{\eta}$ collectively denotes the FI parameters. Let $G_{\mathcal{P}}^{\alpha}(X)$ denote the quiver gauge theory obtained from the theory X via the gauging operation. The partition function of the theory $G_{\mathcal{P}}^{\alpha}(X)$ is therefore given by:

$$Z^{G_{\mathcal{P}}^{\alpha}(X)}(\mathbf{v}^{\alpha}, \dots; \boldsymbol{\eta}, \eta_{\alpha}) = \int [d\mathbf{u}^{\alpha}] \mathcal{Z}_{G_{\mathcal{P}}^{\alpha}(X)}(\mathbf{u}^{\alpha}, \eta_{\alpha}) Z^{(X, \mathcal{P})}(\mathbf{u}^{\alpha}, \mathbf{v}^{\alpha}, \dots; \boldsymbol{\eta}), \quad (3.3)$$

where \mathbf{u}^{α} live in the Cartan subalgebra of the group $U(r_{\alpha})$, $[d\mathbf{u}^{\alpha}] = \frac{\prod_{i=1}^{r_{\alpha}} du_i^{\alpha}}{|W_{\alpha}|}$ with $|W_{\alpha}| = r_{\alpha}!$ being the order of the Weyl group for the new gauge node. The function $\mathcal{Z}_{G_{\mathcal{P}}^{\alpha}(X)}$ is given as

$$\mathcal{Z}_{G_{\mathcal{P}}^{\alpha}(X)}(\mathbf{u}^{\alpha}, \eta_{\alpha}) = Z_{\text{FI}}(\mathbf{u}^{\alpha}, \eta_{\alpha}) Z_{1\text{-loop}}^{\text{vector}}(\mathbf{u}^{\alpha}), \quad (3.4)$$

where $Z_{\text{FI}}(\mathbf{u}^{\alpha}, \eta_{\alpha})$ and $Z_{1\text{-loop}}^{\text{vector}}(\mathbf{u}^{\alpha})$ are the appropriate classical and one-loop contributions respectively of a $U(r_{\alpha})$ vector multiplet.

- **Flavoring operation:** a *flavoring operation* $F_{\mathcal{P}}^{\alpha}$ at a flavor node α of the theory X (shown schematically in figure 9) involves the following two steps:

1. Given the flavor node $U(M_{\alpha})$, we split it into two flavor nodes, corresponding to a $U(r_{\alpha}) \times U(M_{\alpha} - r_{\alpha})$ global symmetry. This requires identifying the $U(1)^{M_{\alpha}}$ background vector multiplets as $U(1)^{r_{\alpha}} \times U(1)^{M_{\alpha} - r_{\alpha}}$ background vector multiplets which is parametrized by a permutation matrix \mathcal{P} , as given in (3.1). The resultant theory is denoted as (X, \mathcal{P}) .
2. Given the theory (X, \mathcal{P}) , we attach a flavor node denoted by G_F^{α} to the flavor node $U(r_{\alpha})$, as shown on the r.h.s. of figure 9. This amounts to introducing some free hypermultiplets in the theory which transform under some representation of the global symmetry group $U(r_{\alpha}) \times G_F^{\alpha}$.

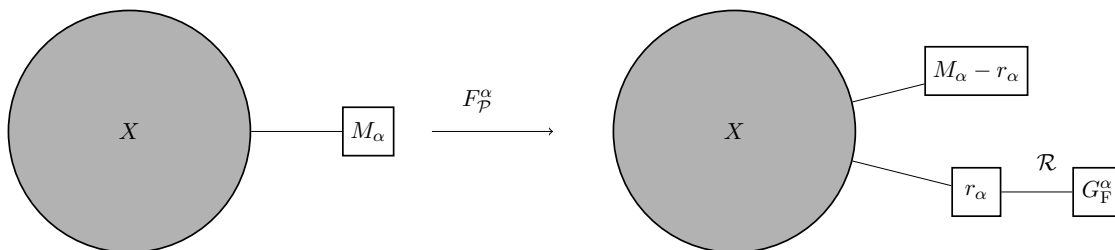

Figure 9. A flavoring operation $F_{\mathcal{P}}^\alpha$ on a $U(M_\alpha)$ subgroup of the global symmetry group of a generic quiver gauge theory (represented by the grey circle).

The operation can be implemented in terms of the S^3 partition function as follows. Let $F_{\mathcal{P}}^\alpha(X)$ denote the theory obtained by implementing the flavoring operation on X . The partition function of the theory $F_{\mathcal{P}}^\alpha(X)$ is then given as (with $Z^{(X,\mathcal{P})}$ defined in (3.2))

$$Z^{F_{\mathcal{P}}^\alpha(X)}(\mathbf{u}^\alpha, \mathbf{v}^\alpha, \dots; \boldsymbol{\eta}) = \mathcal{Z}_{F_{\mathcal{P}}^\alpha(X)}(\mathbf{u}^\alpha, \mathbf{m}_F^\alpha) Z^{(X,\mathcal{P})}(\mathbf{u}^\alpha, \mathbf{v}^\alpha, \dots; \boldsymbol{\eta}). \quad (3.5)$$

The function $\mathcal{Z}_{F_{\mathcal{P}}^\alpha(X)}$ is given as

$$\mathcal{Z}_{F_{\mathcal{P}}^\alpha(X)}(\mathbf{u}^\alpha, \mathbf{m}_F^\alpha) = Z_{1\text{-loop}}^{\text{hyper}}(\mathbf{u}^\alpha, \mathbf{m}_F^\alpha), \quad (3.6)$$

where the factor $Z_{1\text{-loop}}^{\text{hyper}}(\mathbf{u}^\alpha, \mathbf{m}_F^\alpha)$ denotes the contribution of the free hypermultiplets which are charged under the symmetry $U(r_\alpha) \times G_F^\alpha$, with the parameters \mathbf{m}_F^α in the Cartan subalgebra of the group G_F^α .

- **Identification operation:** given the quiver gauge theory X with a global symmetry subgroup $\prod_{\gamma=1}^L U(M_\gamma)$, let $N_{p,r_\alpha}^{\{\gamma_j\}}$ denote a set of (not necessarily consecutive) $p \leq L$ flavor nodes $-\gamma_1, \dots, \gamma_p$, with r_α being a positive integer such that $r_\alpha \leq \text{Min}(\{M_\beta\} | \beta \in N_{p,r_\alpha}^{\{\gamma_j\}})$. Let α be a chosen node in $N_{p,r_\alpha}^{\{\gamma_j\}}$. An identification operation $I_{\mathcal{P}}^\alpha$ (shown schematically in figure 10) is then performed in two steps:

1. For all $\beta \in N_{p,r_\alpha}^{\{\gamma_j\}}$, we split the corresponding flavor node $U(M_\beta)$ into two flavor nodes, associated to a $U(r_\alpha)_\beta \times U(M_\beta - r_\alpha)$ global symmetry. The special case of $p = 2$ nodes $\beta = \alpha - 1, \alpha$, is shown in figure 10. For a given β , the choice of $U(1)_\beta^{r_\alpha} \times U(1)^{M_\beta - r_\alpha}$ background vector multiplets from the original $U(1)^{M_\beta}$ background vector multiplets is parametrized by a permutation matrix \mathcal{P}_β of order M_β , i.e.

$$\vec{m}_{i_\beta}^\beta = (\mathcal{P}_\beta)_{i_\beta i} \vec{u}_i^\beta + (\mathcal{P}_\beta)_{i_\beta r_\alpha + j} \vec{v}_j^\beta, \quad (3.7)$$

where $i_\beta = 1, \dots, M_\beta$, $i = 1, \dots, r_\alpha$, and $j = 1, \dots, M_\beta - r_\alpha$. We denote the resultant theory as $(X, \{\mathcal{P}_\beta\})$.

2. Given the theory $(X, \{\mathcal{P}_\beta\})$, we identify the flavor nodes $U(r_\alpha)_\beta$ for all $\beta \neq \alpha$ to the flavor node $U(r_\alpha)_\alpha$, as shown on the r.h.s. of figure 10.

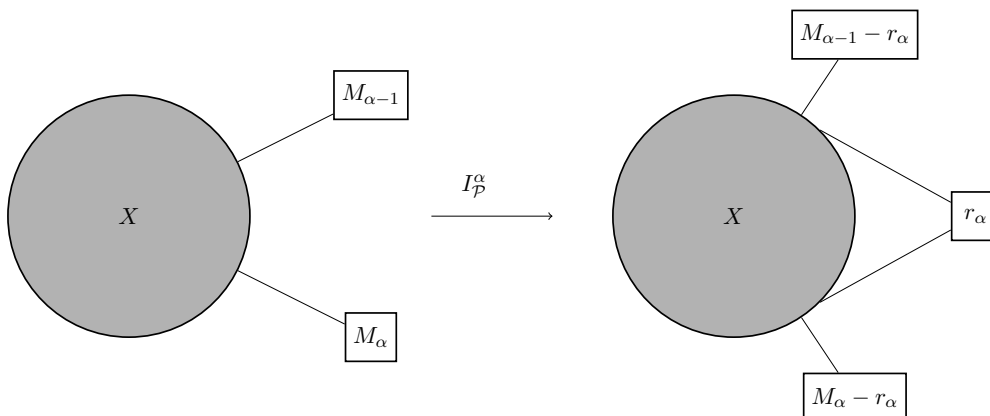

Figure 10. An identification operation $I_{\mathcal{P}}^{\alpha}$ involving two flavor nodes $U(M_{\alpha})$ and $U(M_{\alpha-1})$ in a generic quiver gauge theory.

The identification operation can be implemented in terms of the S^3 partition function in the following fashion. First, the partition function of the theory $(X, \{P_{\beta}\})$ is given as:

$$Z^{(X, \{P_{\beta}\})}(\{u^{\beta}\}, \{v^{\beta}\}, \dots; \boldsymbol{\eta}) =: Z^{(X)}(\{\mathbf{m}^{\beta}(\mathcal{P}_{\beta}, u^{\beta}, v^{\beta})\}, \dots; \boldsymbol{\eta}). \quad (3.8)$$

The identification operation on $(X, \{P_{\beta}\})$ then implies imposing the following constraints on the mass parameters $\{\mathbf{u}^{\beta}\}$:

$$u_i^{\gamma_1} - \mu^{\gamma_1} = u_i^{\gamma_2} - \mu^{\gamma_2} = \dots = u_i^{\gamma_p} - \mu^{\gamma_p} = u_i^{\alpha}, \quad \text{with } i = 1, \dots, r_{\alpha}, \quad (3.9)$$

where $\{\mu^{\gamma_i}\}$ are constant parameters. The choice of $\alpha = \gamma_k$ for a certain $\gamma_k \in N_{p, r_{\alpha}}^{\{\gamma_j\}}$ corresponds to setting $\mu^{\gamma_k} = 0$ in the above equation. We will, however, prefer to keep the parameters $\{\mu^{\gamma_i}\}$ arbitrary in our computation and express the final answer in terms of independent linear combinations of these parameters, instead of using the constraint $\mu^{\gamma_k} = 0$ upfront.

Let $I_{\mathcal{P}}^{\alpha}(X)$ denote the quiver gauge theory obtained by an identification operation on the quiver X . The partition function of $I_{\mathcal{P}}^{\alpha}(X)$ is then given as

$$Z_{I_{\mathcal{P}}^{\alpha}(X)}^{\alpha}(\mathbf{u}^{\alpha}, \{\mathbf{v}^{\beta}\}, \dots, \boldsymbol{\mu}; \boldsymbol{\eta}) = \mathcal{Z}_{I_{\mathcal{P}}^{\alpha}(X)}(\mathbf{u}^{\alpha}, \{\mathbf{u}^{\beta}\}, \boldsymbol{\mu}) \cdot Z^{(X, \{P_{\beta}\})}(\{\mathbf{u}^{\beta}\}, \{\mathbf{v}^{\beta}\}, \dots; \boldsymbol{\eta}), \quad (3.10)$$

where $\mathcal{Z}_{I_{\mathcal{P}}^{\alpha}(X)}$ should be thought of as an operator acting on the function $Z^{(X, \{P_{\beta}\})}$, which is explicitly given as

$$\mathcal{Z}_{I_{\mathcal{P}}^{\alpha}(X)}(\mathbf{u}^{\alpha}, \{\mathbf{u}^{\beta}\}, \boldsymbol{\mu}) = \int \prod_{j=1}^p \prod_{i=1}^{r_{\alpha}} du_i^{\gamma_j} \prod_{j=1}^p \delta^{(r_{\alpha})}(\mathbf{u}^{\alpha} - \mathbf{u}^{\gamma_j} + \boldsymbol{\mu}^{\gamma_j}), \quad (3.11)$$

- **Defect operation:** given a $U(M_{\alpha})$ flavor node of a quiver gauge theory X , the operation $D_{\mathcal{P}}^{\alpha}$ can be defined in the following fashion. One first constructs the theory (X, \mathcal{P}) deformed by the $U(r_{\alpha}) \times U(M_{\alpha} - r_{\alpha})$ masses, as before. One can then turn

on a defect for the flavor node $U(r_\alpha)$, labelled by some data \mathcal{D} . In terms of the S^3 partition function, the operation is implemented as

$$Z^{D_{\mathcal{P}}^\alpha(X)}(\mathbf{u}^\alpha, \mathbf{v}^\alpha, \dots; \boldsymbol{\eta}, \mathcal{D}) = \mathcal{Z}_{D_{\mathcal{P}}^\alpha(X)}(\mathbf{u}^\alpha, \mathcal{D}) Z^{(X, \mathcal{P})}(\mathbf{u}^\alpha, \mathbf{v}^\alpha, \dots; \boldsymbol{\eta}), \quad (3.12)$$

where $D_{\mathcal{P}}^\alpha(X)$ is the quiver obtained by implementing the operation $D_{\mathcal{P}}^\alpha$ on X , and \mathcal{D} is the data associated with the defect. The function $\mathcal{Z}_{D_{\mathcal{P}}^\alpha(X)}$ is given as

$$\mathcal{Z}_{D_{\mathcal{P}}^\alpha(X)}(\mathbf{u}^\alpha, \mathcal{D}) = Z_{\text{defect}}(\mathbf{u}^\alpha, \mathcal{D}). \quad (3.13)$$

The simplest example of such a defect will be a Wilson line in a representation \mathcal{R} of $U(r_\alpha)$. In this case, we have

$$Z_{\text{defect}}(\mathbf{u}^\alpha, \mathcal{D}) := Z_{\text{Wilson}}(\mathbf{u}^\alpha, \mathcal{R}) = \sum_{\rho \in \mathcal{R}} e^{2\pi\rho(\mathbf{u}^\alpha)}, \quad (3.14)$$

where ρ is a weight of the representation \mathcal{R} of $U(r_\alpha)$.

Definition. An elementary S -type operation $\mathcal{O}_{\mathcal{P}}^\alpha$ on X at a flavor node α , is defined by the action of any possible combination of the $F_{\mathcal{P}}^\alpha$, $I_{\mathcal{P}}^\alpha$, and $D_{\mathcal{P}}^\alpha$ operations followed by a *single* gauging operation $G_{\mathcal{P}}^\alpha$.

$$\mathcal{O}_{\mathcal{P}}^\alpha(X) := (G_{\mathcal{P}}^\alpha) \circ (F_{\mathcal{P}}^\alpha)^{n_3} \circ (I_{\mathcal{P}}^\alpha)^{n_2} \circ (D_{\mathcal{P}}^\alpha)^{n_1}(X), \quad (n_i = 0, 1, \forall i). \quad (3.15)$$

The operation $\mathcal{O}_{\mathcal{P}}^\alpha$ can be implemented in terms of the partition function as follows. Let β label the flavor nodes of the theory X on which the given S -type operation $\mathcal{O}_{\mathcal{P}}^\alpha$ acts, via identification/gauging operations. The partition function of the theory $\mathcal{O}_{\mathcal{P}}^\alpha(X)$ is then given by

$$Z^{\mathcal{O}_{\mathcal{P}}^\alpha(X)} = \int [d\mathbf{u}^\alpha] \mathcal{Z}_{\mathcal{O}_{\mathcal{P}}^\alpha(X)}(\mathbf{u}^\alpha, \{\mathbf{u}^\beta\}, \eta_\alpha, \mathbf{m}^{\mathcal{O}_{\mathcal{P}}^\alpha}, \mathcal{D}) \cdot Z^{(X, \{P_\beta\})}(\{\mathbf{u}^\beta\}, \{\mathbf{v}^\beta\}, \dots; \boldsymbol{\eta}), \quad (3.16)$$

where $\mathcal{Z}_{\mathcal{O}_{\mathcal{P}}^\alpha(X)}$ should be understood as an operator acting on the function $Z^{(X, \{P_\beta\})}$. The explicit operator can be constructed using the expressions of $\mathcal{Z}_{G_{\mathcal{P}}^\alpha(X)}$, $\mathcal{Z}_{F_{\mathcal{P}}^\alpha(X)}$, $\mathcal{Z}_{I_{\mathcal{P}}^\alpha(X)}$, and $\mathcal{Z}_{D_{\mathcal{P}}^\alpha(X)}$, given in (3.4), (3.6), (3.11) and (3.13) respectively, and following the definition (3.15) of $\mathcal{O}_{\mathcal{P}}^\alpha$ in terms of the gauging, flavoring, identification, and defect operations:

$$\mathcal{Z}_{\mathcal{O}_{\mathcal{P}}^\alpha(X)} = \mathcal{Z}_{G_{\mathcal{P}}^\alpha(X)} \cdot \left(\mathcal{Z}_{F_{\mathcal{P}}^\alpha(X)}\right)^{n_3} \cdot \left(\mathcal{Z}_{I_{\mathcal{P}}^\alpha(X)}\right)^{n_2} \cdot \left(\mathcal{Z}_{D_{\mathcal{P}}^\alpha(X)}\right)^{n_1}, \quad (3.17)$$

where the dependence on the mass and FI parameters is implicit. A generic S -type operation on the quiver gauge theory X is defined simply as the action of successive elementary S -type operations:

$$\mathcal{O}_{(\mathcal{P}_1, \dots, \mathcal{P}_l)}^{(\alpha_1, \dots, \alpha_l)}(X) := \mathcal{O}_{\mathcal{P}_l}^{\alpha_l} \circ \mathcal{O}_{\mathcal{P}_{l-1}}^{\alpha_{l-1}} \circ \dots \circ \mathcal{O}_{\mathcal{P}_2}^{\alpha_2} \circ \mathcal{O}_{\mathcal{P}_1}^{\alpha_1}(X). \quad (3.18)$$

Note that the gauging operation in a given constituent elementary S -type operation can either involve flavor symmetries present in the theory X , or flavor symmetries introduced

by a previous $\mathcal{O}_{\mathcal{P}}^\alpha$. The partition function of the theory $\mathcal{O}_{(\mathcal{P}_1, \dots, \mathcal{P}_l)}^{(\alpha_1, \dots, \alpha_l)}(X)$ can be obtained by using (3.16) iteratively.

Finally, let us define an elementary T -type operation $T_{\mathcal{P}}^\alpha$, analogous to Witten's T operation in [3]), at a flavor node α of the quiver gauge theory X . Given a flavor node $U(M_\alpha)$ of X , one first constructs the theory (X, \mathcal{P}) deformed by the $U(r_\alpha) \times U(M_\alpha - r_\alpha)$ masses. Then, one turns on a Chern-Simons term for the flavor symmetry group $U(r_\alpha)$. In terms of the S^3 partition function, the operation is implemented as

$$\begin{aligned} Z_{\mathcal{P}}^{T_{\mathcal{P}}^\alpha(X)}(\mathbf{u}^\alpha, \mathbf{v}^\alpha, \dots; \boldsymbol{\eta}, k) &= Z_{T_{\mathcal{P}}^\alpha}(\mathbf{u}^\alpha, k) Z^{(X, \mathcal{P})}(\mathbf{u}^\alpha, \mathbf{v}^\alpha, \dots; \boldsymbol{\eta}) \\ &= Z_{\text{CS}}(\mathbf{u}^\alpha, k) Z^{(X, \mathcal{P})}(\mathbf{u}^\alpha, \mathbf{v}^\alpha, \dots; \boldsymbol{\eta}), \end{aligned} \quad (3.19)$$

where $T_{\mathcal{P}}^\alpha(X)$ is the quiver obtained by implementing the operation $T_{\mathcal{P}}^\alpha$ on X , k is the level of the Chern-Simons term, and $Z_{\text{CS}}(\mathbf{u}^\alpha, k)$ is the partition function contribution of the Chern-Simons term given in (2.15). Obviously, one can consider the action of generic operations built out of elementary S -type and T -type operations on the quiver X . The partition function of the resultant theory can be written down by combining (3.16) and (3.19) appropriately.

3.2 Construction of generic quivers from linear quivers using S -type operations

Given a quiver gauge theory X in class \mathcal{U} and an elementary S -type operation $\mathcal{O}_{\mathcal{P}}^\alpha$, finding the mirror dual of the theory $\mathcal{O}_{\mathcal{P}}^\alpha(X)$ requires knowing the mirror dual of the theory X . For a generic X , the mirror dual Y is obviously unknown, and there is no guarantee that Y will be a Lagrangian theory. Therefore, one needs a convenient starting point where both the theories X and Y are good Lagrangian theories, and the map of masses and FI parameters across the duality is explicitly known.

Our strategy in this paper will be to construct a quiver gauge theory X' from a good linear quiver X using a sequence of elementary S -type operations with no defects. The dual of the theory X' can then be read off from the associated dual operations on the good linear quiver Y .⁸ In this subsection, we will present the formula for the partition function realization of an elementary S -type operation on a linear quiver X , discussing the four distinct types of S -type operations separately. In section 3.3, we will present the corresponding dual operations.

Consider a generic linear quiver theory X with L nodes, as shown in figure 3. The mass parameters of X can be parametrized in the following fashion:

$$m_i = \{m_{i_1}^1, m_{i_2}^2, \dots, m_{i_\alpha}^\alpha, \dots, m_{i_{L-1}}^{L-1}, m_{i_L}^L\}, \quad i = 1, \dots, L^\vee + 1, \quad (3.20)$$

with $i_1 = 1, \dots, M_1$, $i_2 = 1, \dots, M_2, \dots$, $i_\alpha = 1, \dots, M_\alpha$, $i_L = 1, \dots, M_L$, and $L^\vee = \sum_{\gamma=1}^L M_\gamma - 1$. Recall that the Higgs branch global symmetry of X is $G_H^{(X)} = (\prod_{\gamma=1}^L U(M_\gamma))/U(1)$. If β labels the set of flavor nodes on which an $\mathcal{O}_{\mathcal{P}}^\alpha$ acts, then we will

⁸The mirror dual of a good linear quiver is guaranteed to be a good linear quiver [27]. Note that this is only true for a linear quiver, and not for quivers of arbitrary shape.

assume that the $U(1)$ quotient has been implemented by constraining some mass parameters $\{m_{i_{\alpha'}}^{\alpha'}\}$ with $\alpha' \neq \beta$, so that the parameters $\{m_{i_{\beta}}^{\beta}\}$ for all β are completely unconstrained. Also, let the FI parameters of the linear quiver in figure 3 be parametrized as

$$\eta_{\gamma} = t_{\gamma} - t_{\gamma+1}, \quad \gamma = 1, \dots, L. \quad (3.21)$$

Now, proceeding in the same fashion as in section 3.1, we can write down the partition function of the theory $\mathcal{O}_{\mathcal{P}}^{\alpha}(X)$ with X being a linear quiver:

$$Z^{\mathcal{O}_{\mathcal{P}}^{\alpha}(X)} = \int [d\mathbf{u}^{\alpha}] \mathcal{Z}_{\mathcal{O}_{\mathcal{P}}^{\alpha}(X)}(\mathbf{u}^{\alpha}, \{\mathbf{u}^{\beta}\}, \eta_{\alpha}, \mathbf{m}^{\mathcal{O}_{\mathcal{P}}^{\alpha}}) \cdot Z^{(X, \{P_{\beta}\})}(\{\mathbf{u}^{\beta}\}, \{\mathbf{v}^{\beta}\}, \{\mathbf{m}^{\gamma}\}_{\gamma \neq \alpha}; \mathbf{t}), \quad (3.22)$$

where the operator $\mathcal{Z}_{\mathcal{O}_{\mathcal{P}}^{\alpha}(X)}$ can be constructed from the gauging, flavoring and identification operators, as described in (3.17), and the function $Z^{(X, \{P_{\beta}\})}$ is defined as

$$Z^{(X, \{P_{\beta}\})}(\{\mathbf{u}^{\beta}\}, \{\mathbf{v}^{\beta}\}, \{\mathbf{m}^{\gamma}\}_{\gamma \neq \alpha}; \mathbf{t}) := Z^{(X)}(\{\mathbf{m}^{\beta}(\mathcal{P}_{\beta}, u^{\beta}, v^{\beta})\}, \{\mathbf{m}^{\gamma}\}_{\gamma \neq \alpha}; \mathbf{t}). \quad (3.23)$$

One can then continue building more general quivers by implementing another elementary S -type operation on the quiver $\mathcal{O}_{\mathcal{P}}^{\alpha}(X)$ (which is generically not a linear quiver), and so on, following the general recipe given in (3.16) for implementing S -type operations on a generic quiver.

We would like to emphasize that the Lagrangian of the theory $\mathcal{O}_{\mathcal{P}}^{\alpha}(X)$ is manifestly independent of the permutation matrices \mathcal{P} . However, as we will see in the discussion of the dual operations, the Lagrangian of the theory dual to $\mathcal{O}_{\mathcal{P}}^{\alpha}(X)$ manifestly depends on the data \mathcal{P} . This is related to the fact that while the integrand for the partition function of X is manifestly invariant under a permutation of the M_{β} masses \mathbf{m}^{β} for a given β , the integrand for the partition function of Y (where \mathbf{m}^{β} appear as FI parameters) is not.

The four distinct types of elementary S -type operations can be read off from (3.15), when no defect is turned on. We will now present the partition function realization of these operations on linear quivers. Extending these operations to generic quivers is straightforward, and the corresponding partition functions can be written down from the general formula (3.16).

- **Gauging operation:** the simplest example of an elementary S -type operation is a gauging operation acting on a flavor node α of the quiver X , as shown in figure 11. The partition function of the theory $G_{\mathcal{P}}^{\alpha}(X)$ is given by:

$$Z^{G_{\mathcal{P}}^{\alpha}(X)}(\mathbf{v}^{\alpha}, \{\mathbf{m}^{\gamma}\}_{\gamma \neq \alpha}; \mathbf{t}, \eta_{\alpha}) = \int [d\mathbf{u}^{\alpha}] \mathcal{Z}_{G_{\mathcal{P}}^{\alpha}(X)}(\mathbf{u}^{\alpha}, \eta_{\alpha}) Z^{(X, \mathcal{P})}(\mathbf{u}^{\alpha}, \mathbf{v}^{\alpha}, \{\mathbf{m}^{\gamma}\}_{\gamma \neq \alpha}; \mathbf{t}), \quad (3.24)$$

where the function $\mathcal{Z}_{G_{\mathcal{P}}^{\alpha}(X)}$ is given as

$$\mathcal{Z}_{G_{\mathcal{P}}^{\alpha}(X)}(\mathbf{u}^{\alpha}, \eta_{\alpha}) = Z_{\text{FI}}(\mathbf{u}^{\alpha}, \eta_{\alpha}) Z_{1\text{-loop}}^{\text{vector}}(\mathbf{u}^{\alpha}). \quad (3.25)$$

Using the results (3.2), (3.25) and (2.27), the partition function can be put in the standard form of (2.14) (with no defects):

$$Z^{G_{\mathcal{P}}^{\alpha}(X)}(\mathbf{v}^{\alpha}, \{\mathbf{m}^{\gamma}\}_{\gamma \neq \alpha}; \mathbf{t}, \eta_{\alpha}) =: \int [d\mathbf{u}^{\alpha}] \prod_{\gamma=1}^L [ds^{\gamma}] Z_{\text{FI}}^{G_{\mathcal{P}}^{\alpha}(X)} \cdot Z_{1\text{-loop}}^{G_{\mathcal{P}}^{\alpha}(X)}, \quad (3.26)$$

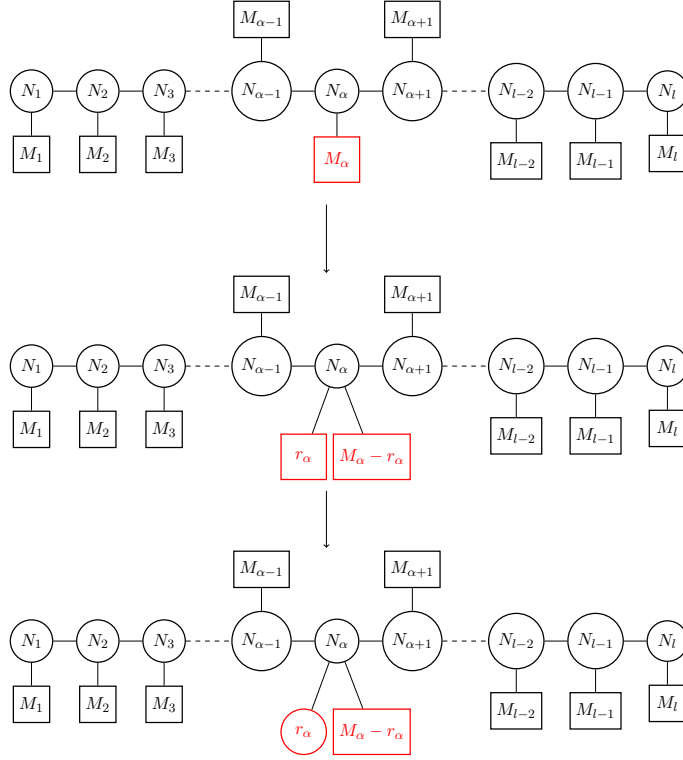

Figure 11. This figure illustrates the gauging operation $G_{\mathcal{P}}^{\alpha}$ on a generic linear quiver X at a flavor node $U(M_{\alpha})$.

where the functions $Z_{\text{FI}}^{G_{\mathcal{P}}^{\alpha}(X)}$ and $Z_{1\text{-loop}}^{G_{\mathcal{P}}^{\alpha}(X)}$ are given as

$$\begin{aligned}
 Z_{\text{FI}}^{G_{\mathcal{P}}^{\alpha}(X)}(\{\mathbf{s}^{\gamma}\}, \mathbf{u}^{\alpha}, \mathbf{t}, \eta_{\alpha}) &= Z_{\text{FI}}(\mathbf{u}^{\alpha}, \eta_{\alpha}) Z_{\text{FI}}^{(X)}(\{\mathbf{s}^{\gamma}\}, \mathbf{t}), \\
 Z_{1\text{-loop}}^{G_{\mathcal{P}}^{\alpha}(X)}(\{\mathbf{s}^{\gamma}\}, \mathbf{u}^{\alpha}, \{\mathbf{m}^{\gamma}\}_{\gamma \neq \alpha}, \mathbf{v}^{\alpha}) &= \left(Z_{1\text{-loop}}^{\text{vector}}(\mathbf{u}^{\alpha}) \prod_{\gamma=1}^L Z_{1\text{-loop}}^{\text{vector}}(\mathbf{s}^{\gamma}) \right) \\
 &\times \left(Z_{1\text{-loop}}^{\text{fund}}(\mathbf{s}^{\alpha}, \mathbf{v}^{\alpha}) \prod_{\gamma \neq \alpha} Z_{1\text{-loop}}^{\text{fund}}(\mathbf{s}^{\gamma}, \mathbf{m}^{\gamma}) \right) \\
 &\times \left(Z_{1\text{-loop}}^{\text{bif}}(\mathbf{s}^{\alpha}, \mathbf{u}^{\alpha}, 0) \prod_{\gamma=1}^{L-1} Z_{1\text{-loop}}^{\text{bif}}(\mathbf{s}^{\gamma}, \mathbf{s}^{\gamma+1}, 0) \right).
 \end{aligned} \tag{3.27}$$

$$\tag{3.28}$$

The Lagrangian of the theory $G_{\mathcal{P}}^{\alpha}(X)$ can be read off from the integrand of the matrix integral on the r.h.s. of (3.26), and reproduces the quiver gauge theory in the third line of figure 11.

- **Flavoring-gauging operation.** The second elementary S -type operation involves a flavoring operation combined with a gauging operation, as shown in figure 12. In the notation of (3.15), the combined operation can be denoted as

$$\mathcal{O}_{\mathcal{P}}^{\alpha}(X) = G_{\mathcal{P}}^{\alpha} \circ F_{\mathcal{P}}^{\alpha}(X), \tag{3.29}$$

where \mathcal{P} is a permutation matrix of order M_α . We will refer to $\mathcal{O}_{\mathcal{P}}^\alpha$ as the *flavoring-gauging* operation. Following (3.22), the partition function of the theory $G_{\mathcal{P}}^\alpha \circ F_{\mathcal{P}}^\alpha(X)$ is given as:

$$\begin{aligned} & Z^{G_{\mathcal{P}}^\alpha \circ F_{\mathcal{P}}^\alpha(X)}(\mathbf{v}^\alpha, \mathbf{m}_F^\alpha, \{\mathbf{m}^\gamma\}_{\gamma \neq \alpha}; \mathbf{t}, \eta_\alpha) \\ &= \int [d\mathbf{u}^\alpha] \mathcal{Z}_{G_{\mathcal{P}}^\alpha \circ F_{\mathcal{P}}^\alpha(X)}(\mathbf{u}^\alpha, \mathbf{m}_F^\alpha, \eta_\alpha) Z^{(X, \mathcal{P})}(\mathbf{u}^\alpha, \mathbf{v}^\alpha, \{\mathbf{m}^\gamma\}_{\gamma \neq \alpha}; \mathbf{t}), \end{aligned} \quad (3.30)$$

where the function $\mathcal{Z}_{G_{\mathcal{P}}^\alpha \circ F_{\mathcal{P}}^\alpha(X)}$ can be constructed using (3.17):

$$\mathcal{Z}_{G_{\mathcal{P}}^\alpha \circ F_{\mathcal{P}}^\alpha(X)}(\mathbf{u}^\alpha, \mathbf{m}_F^\alpha, \eta_\alpha) = Z_{\text{FI}}(\mathbf{u}^\alpha, \eta_\alpha) Z_{1\text{-loop}}^{\text{vector}}(\mathbf{u}^\alpha) Z_{1\text{-loop}}^{\text{hyper}}(\mathbf{u}^\alpha, \mathbf{m}_F^\alpha). \quad (3.31)$$

Using the results (3.2), (3.31) and (2.27), the partition function can be put in the standard form of (2.14) (with no defects):

$$Z^{G_{\mathcal{P}}^\alpha \circ F_{\mathcal{P}}^\alpha(X)}(\mathbf{v}^\alpha, \mathbf{m}_F^\alpha, \{\mathbf{m}^\gamma\}_{\gamma \neq \alpha}; \mathbf{t}, \eta_\alpha) =: \int [d\mathbf{u}^\alpha] \prod_{\gamma=1}^L [d\mathbf{s}^\gamma] Z_{\text{FI}}^{G_{\mathcal{P}}^\alpha \circ F_{\mathcal{P}}^\alpha(X)} \cdot Z_{1\text{-loop}}^{G_{\mathcal{P}}^\alpha \circ F_{\mathcal{P}}^\alpha(X)}, \quad (3.32)$$

where the functions $Z_{\text{FI}}^{G_{\mathcal{P}}^\alpha \circ F_{\mathcal{P}}^\alpha(X)}$ and $Z_{1\text{-loop}}^{G_{\mathcal{P}}^\alpha \circ F_{\mathcal{P}}^\alpha(X)}$ are given as

$$\begin{aligned} & Z_{\text{FI}}^{G_{\mathcal{P}}^\alpha \circ F_{\mathcal{P}}^\alpha(X)}(\{\mathbf{s}^\gamma\}, \mathbf{u}^\alpha, \mathbf{t}, \eta_\alpha) = Z_{\text{FI}}(\mathbf{u}^\alpha, \eta_\alpha) Z_{\text{FI}}^{(X)}(\{\mathbf{s}^\gamma\}, \mathbf{t}), \quad (3.33) \\ & Z_{1\text{-loop}}^{G_{\mathcal{P}}^\alpha \circ F_{\mathcal{P}}^\alpha(X)}(\{\mathbf{s}^\gamma\}, \mathbf{u}^\alpha, \{\mathbf{m}^\gamma\}_{\gamma \neq \alpha}, \mathbf{v}^\alpha, \mathbf{m}_F^\alpha) = \left(Z_{1\text{-loop}}^{\text{vector}}(\mathbf{u}^\alpha) \prod_{\gamma=1}^L Z_{1\text{-loop}}^{\text{vector}}(\mathbf{s}^\gamma) \right) \\ & \quad \times \left(Z_{1\text{-loop}}^{\text{fund}}(\mathbf{u}^\alpha, \mathbf{m}_F^\alpha) Z_{1\text{-loop}}^{\text{fund}}(\mathbf{s}^\alpha, \mathbf{v}^\alpha) \prod_{\gamma \neq \alpha} Z_{1\text{-loop}}^{\text{fund}}(\mathbf{s}^\gamma, \mathbf{m}^\gamma) \right) \\ & \quad \times \left(Z_{1\text{-loop}}^{\text{bif}}(\mathbf{s}^\alpha, \mathbf{u}^\alpha, 0) \prod_{\gamma=1}^{L-1} Z_{1\text{-loop}}^{\text{bif}}(\mathbf{s}^\gamma, \mathbf{s}^{\gamma+1}, 0) \right). \end{aligned} \quad (3.34)$$

The Lagrangian of the theory $G_{\mathcal{P}}^\alpha \circ F_{\mathcal{P}}^\alpha(X)$ can be read off from the integrand of the matrix integral on the r.h.s. of (3.32), and reproduces the quiver gauge theory in the third line of figure 12. The parameters \mathbf{m}_F^α , which live in the Cartan subalgebra of G_F^α , can be identified as masses of the added hypermultiplets.

- **Identification-gauging operation:** the third elementary S -type operation involves an identification operation combined with a gauging operation, as shown in figure 13 for $p = 3$ nodes. In the notation of (3.15), the combined operation can be denoted as

$$\mathcal{O}_{\mathcal{P}}^\alpha(X) = G_{\mathcal{P}}^\alpha \circ I_{\mathcal{P}}^\alpha(X) \quad (3.35)$$

where $\mathcal{P} = \{\mathcal{P}_\beta\}$ collectively denotes the permutation matrices of order M_β . We will refer to as $\mathcal{O}_{\mathcal{P}}^\alpha$ as the *identification-gauging* operation. The quiver gauge theory $G_{\mathcal{P}}^\alpha \circ I_{\mathcal{P}}^\alpha(X)$ has the partition function:

$$\begin{aligned} & Z^{G_{\mathcal{P}}^\alpha \circ I_{\mathcal{P}}^\alpha(X)}(\{\mathbf{v}^\beta\}, \{\mathbf{m}^\gamma\}_{\gamma \neq \beta}, \boldsymbol{\mu}; \mathbf{t}, \eta_\alpha) \\ &= \int [d\mathbf{u}^\alpha] \mathcal{Z}_{G_{\mathcal{P}}^\alpha \circ I_{\mathcal{P}}^\alpha(X)}(\mathbf{u}^\alpha, \{\mathbf{u}^\beta\}, \eta_\alpha, \boldsymbol{\mu}) Z^{(X, \{\mathcal{P}_\beta\})}(\{\mathbf{u}^\beta\}, \{\mathbf{v}^\beta\}, \{\mathbf{m}^\gamma\}_{\gamma \neq \beta}; \mathbf{t}), \end{aligned} \quad (3.36)$$

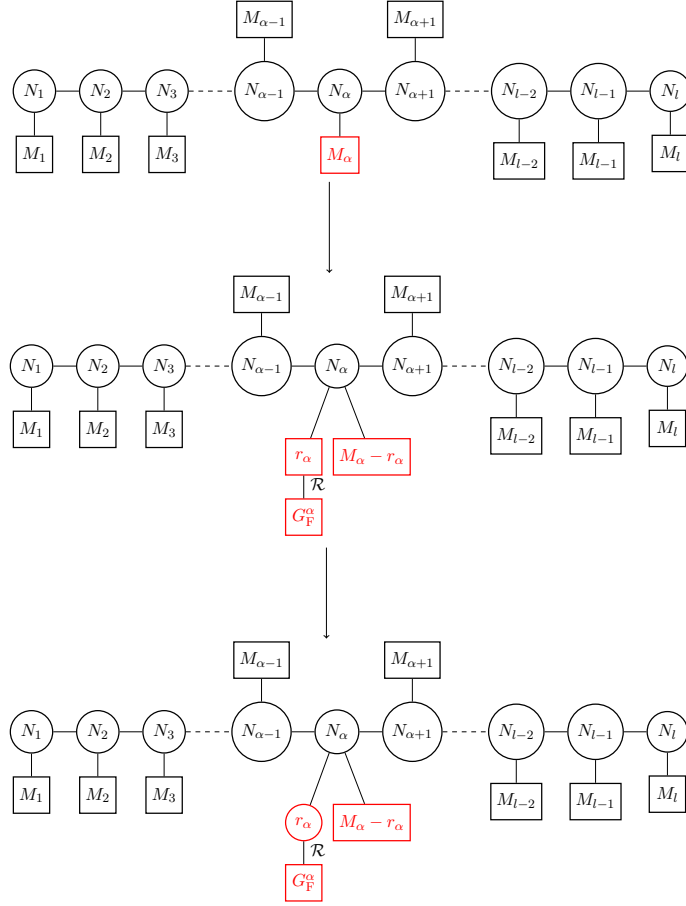

Figure 12. This figure illustrates the flavoring-gauging operation $G_{\mathcal{P}}^{\alpha} \circ F_{\mathcal{P}}^{\alpha}$ on a generic linear quiver X at the flavor node $U(M_{\alpha})$.

where $\mathcal{Z}_{G_{\mathcal{P}}^{\alpha} \circ I_{\mathcal{P}}^{\alpha}(X)}$ is an operator of the following form:

$$\mathcal{Z}_{G_{\mathcal{P}}^{\alpha} \circ I_{\mathcal{P}}^{\alpha}(X)} = Z_{\text{FI}}(\mathbf{u}^{\alpha}, \eta_{\alpha}) Z_{1\text{-loop}}^{\text{vector}}(\mathbf{u}^{\alpha}) \int \prod_{j=1}^p \prod_{i=1}^{r_{\alpha}} du_i^{\gamma_j} \prod_{j=1}^p \delta^{(r_{\alpha})}(\mathbf{u}^{\alpha} - \mathbf{u}^{\gamma_j} + \mu^{\gamma_j}). \quad (3.37)$$

Using the results (3.2), (3.37) and (2.27), the partition function can be put in the standard form of (2.14) (with no defects):

$$Z_{G_{\mathcal{P}}^{\alpha} \circ I_{\mathcal{P}}^{\alpha}(X)}(\{\mathbf{v}^{\beta}\}, \{\mathbf{m}^{\gamma}\}_{\gamma \neq \beta}, \boldsymbol{\mu}; \mathbf{t}, \eta_{\alpha}) =: \int [d\mathbf{u}^{\alpha}] \prod_{\gamma=1}^L [d\mathbf{s}^{\gamma}] Z_{\text{FI}}^{G_{\mathcal{P}}^{\alpha} \circ I_{\mathcal{P}}^{\alpha}(X)} \cdot Z_{1\text{-loop}}^{G_{\mathcal{P}}^{\alpha} \circ I_{\mathcal{P}}^{\alpha}(X)}, \quad (3.38)$$

where the functions $Z_{\text{FI}}^{G_{\mathcal{P}}^{\alpha} \circ I_{\mathcal{P}}^{\alpha}(X)}$ and $Z_{1\text{-loop}}^{G_{\mathcal{P}}^{\alpha} \circ I_{\mathcal{P}}^{\alpha}(X)}$ are given as

$$\begin{aligned}
 Z_{\text{FI}}^{G_{\mathcal{P}}^{\alpha} \circ I_{\mathcal{P}}^{\alpha}(X)}(\{\mathbf{s}^{\gamma}\}, \mathbf{u}^{\alpha}, \mathbf{t}, \eta_{\alpha}) &= Z_{\text{FI}}(\mathbf{u}^{\alpha}, \eta_{\alpha}) Z_{\text{FI}}^{(X)}(\{\mathbf{s}^{\gamma}\}, \mathbf{t}), \quad (3.39) \\
 Z_{1\text{-loop}}^{G_{\mathcal{P}}^{\alpha} \circ I_{\mathcal{P}}^{\alpha}(X)}(\{\mathbf{s}^{\gamma}\}, \mathbf{u}^{\alpha}, \{\mathbf{m}^{\gamma}\}_{\gamma \neq \beta}, \{\mathbf{v}^{\beta}\}, \boldsymbol{\mu}) &= \left(Z_{1\text{-loop}}^{\text{vector}}(\mathbf{u}^{\alpha}) \prod_{\gamma=1}^L Z_{1\text{-loop}}^{\text{vector}}(\mathbf{s}^{\gamma}) \right) \\
 &\times \left(\prod_{j=1}^p Z_{1\text{-loop}}^{\text{fund}}(\mathbf{s}^{\gamma_j}, \mathbf{v}^{\gamma_j}) \prod_{\gamma \neq \beta} Z_{1\text{-loop}}^{\text{fund}}(\mathbf{s}^{\gamma}, \mathbf{m}^{\gamma}) \right) \\
 &\times \left(\prod_{j=1}^p Z_{1\text{-loop}}^{\text{bif}}(\mathbf{s}^{\gamma_j}, \mathbf{u}^{\alpha}, -\boldsymbol{\mu}^{\gamma_j}) \prod_{\gamma=1}^{L-1} Z_{1\text{-loop}}^{\text{bif}}(\mathbf{s}^{\gamma}, \mathbf{s}^{\gamma+1}, 0) \right). \quad (3.40)
 \end{aligned}$$

The Lagrangian can now be read off from the integrand of the matrix model on the r.h.s. of (3.38), and agrees with the quiver gauge theory in the third line of figure 13. Note that the parameters $\boldsymbol{\mu}$ appear as masses of the hypermultiplets in the bifundamental of $U(M_{\gamma_j}) \times U(r)$.

- **Identification-flavoring-gauging operation:** the fourth elementary S -type operation involves a combination of an identification operation, a flavoring operation, and a gauging operation, as shown in figure 14 for $p = 3$ nodes. In the notation of (3.15), therefore, the combined operation can be denoted as

$$\mathcal{O}_{\mathcal{P}}^{\alpha}(X) = G_{\mathcal{P}}^{\alpha} \circ F_{\mathcal{P}}^{\alpha} \circ I_{\mathcal{P}}^{\alpha}(X) \quad (3.41)$$

where $\mathcal{P} = \{\mathcal{P}_{\beta}\}$ collectively denotes the permutation matrices of order M_{β} . We will refer to as $\mathcal{O}_{\mathcal{P}}^{\alpha}$ as the *identification-flavoring-gauging* operation. The quiver gauge theory $G_{\mathcal{P}}^{\alpha} \circ F_{\mathcal{P}}^{\alpha} \circ I_{\mathcal{P}}^{\alpha}(X)$ has the partition function:

$$\begin{aligned}
 Z_{G_{\mathcal{P}}^{\alpha} \circ F_{\mathcal{P}}^{\alpha} \circ I_{\mathcal{P}}^{\alpha}(X)}(\{\mathbf{v}^{\beta}\}, \{\mathbf{m}^{\gamma}\}_{\gamma \neq \beta}, \boldsymbol{\mu}, \mathbf{m}_F^{\alpha}; \mathbf{t}, \eta_{\alpha}) \quad (3.42) \\
 = \int [d\mathbf{u}^{\alpha}] \mathcal{Z}_{G_{\mathcal{P}}^{\alpha} \circ F_{\mathcal{P}}^{\alpha} \circ I_{\mathcal{P}}^{\alpha}(X)}(\mathbf{u}^{\alpha}, \{\mathbf{u}^{\beta}\}, \eta_{\alpha}, \boldsymbol{\mu}, \mathbf{m}_F^{\alpha}) Z^{(X, \{P_{\beta}\})}(\{\mathbf{u}^{\beta}\}, \{\mathbf{v}^{\beta}\}, \{\mathbf{m}^{\gamma}\}_{\gamma \neq \beta}; \mathbf{t}),
 \end{aligned}$$

where $\mathcal{Z}_{G_{\mathcal{P}}^{\alpha} \circ F_{\mathcal{P}}^{\alpha} \circ I_{\mathcal{P}}^{\alpha}(X)}$ is an operator of the following form:

$$\begin{aligned}
 \mathcal{Z}_{G_{\mathcal{P}}^{\alpha} \circ F_{\mathcal{P}}^{\alpha} \circ I_{\mathcal{P}}^{\alpha}(X)} &= Z_{\text{FI}}(\mathbf{u}^{\alpha}, \eta_{\alpha}) Z_{1\text{-loop}}^{\text{vector}}(\mathbf{u}^{\alpha}) Z_{1\text{-loop}}^{\text{hyper}}(\mathbf{u}^{\alpha}, \mathbf{m}_F^{\alpha}) \\
 &\times \int \prod_{j=1}^p \prod_{i=1}^{r_{\alpha}} du_i^{\gamma_j} \prod_{j=1}^p \delta^{(r_{\alpha})}(\mathbf{u}^{\alpha} - \mathbf{u}^{\gamma_j} + \boldsymbol{\mu}^{\gamma_j}). \quad (3.43)
 \end{aligned}$$

By using the result (3.2) and the formula (2.27), the partition function can be put in the standard form of (2.14) (with no defects):

$$Z_{G_{\mathcal{P}}^{\alpha} \circ F_{\mathcal{P}}^{\alpha} \circ I_{\mathcal{P}}^{\alpha}(X)} =: \int [d\mathbf{u}^{\alpha}] \prod_{\gamma=1}^L [ds^{\gamma}] Z_{\text{FI}}^{G_{\mathcal{P}}^{\alpha} \circ F_{\mathcal{P}}^{\alpha} \circ I_{\mathcal{P}}^{\alpha}(X)} \cdot Z_{1\text{-loop}}^{G_{\mathcal{P}}^{\alpha} \circ F_{\mathcal{P}}^{\alpha} \circ I_{\mathcal{P}}^{\alpha}(X)}, \quad (3.44)$$

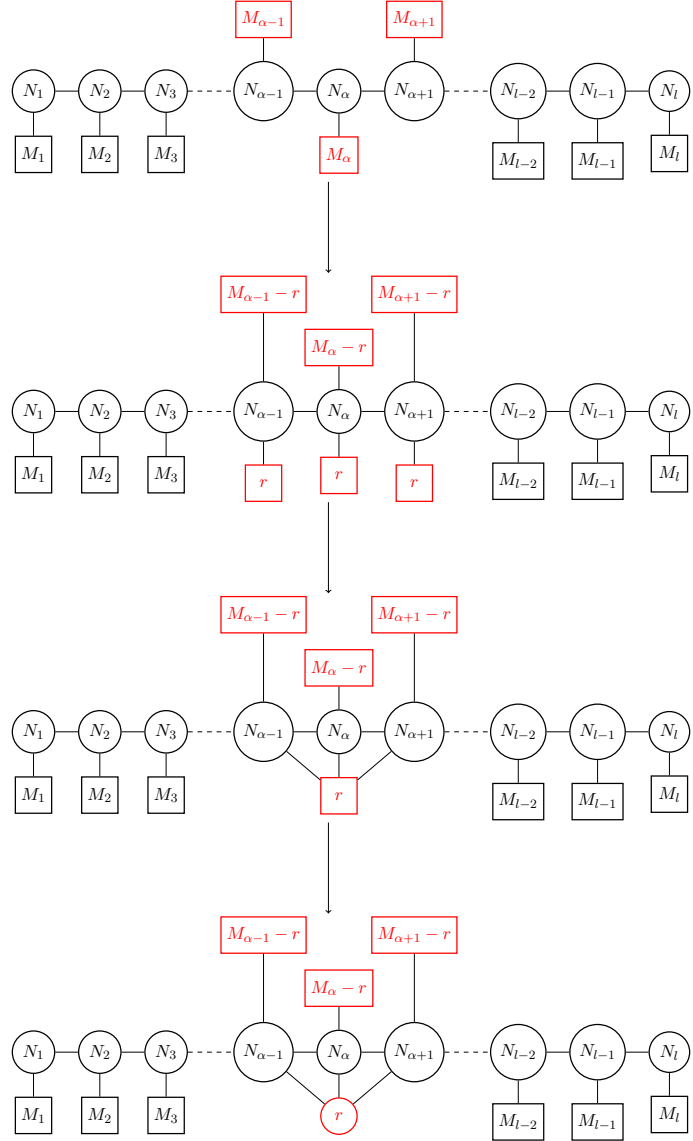

Figure 13. This figure illustrates the identification-gauging $G_{\mathcal{P}}^\alpha \circ I_{\mathcal{P}}^\alpha$ operation on a generic linear quiver X involving $p = 3$ nodes labelled by $\beta = \alpha - 1, \alpha, \alpha + 1$.

where the functions $Z_{\text{FI}}^{G_{\mathcal{P}}^\alpha \circ F_{\mathcal{P}}^\alpha \circ I_{\mathcal{P}}^\alpha(X)}$ and $Z_{1\text{-loop}}^{G_{\mathcal{P}}^\alpha \circ F_{\mathcal{P}}^\alpha \circ I_{\mathcal{P}}^\alpha(X)}$ are given as

$$Z_{\text{FI}}^{G_{\mathcal{P}}^\alpha \circ F_{\mathcal{P}}^\alpha \circ I_{\mathcal{P}}^\alpha(X)}(\{\mathbf{s}^\gamma\}, u^\alpha, \mathbf{t}, \eta_\alpha) = Z_{\text{FI}}(\mathbf{u}^\alpha, \eta_\alpha) Z_{\text{FI}}^{(X)}(\{\mathbf{s}^\gamma\}, \mathbf{t}), \quad (3.45)$$

$$\begin{aligned} Z_{1\text{-loop}}^{G_{\mathcal{P}}^\alpha \circ F_{\mathcal{P}}^\alpha \circ I_{\mathcal{P}}^\alpha(X)}(\{\mathbf{s}^\gamma\}, \mathbf{u}^\alpha, \{\mathbf{m}^\gamma\}_{\gamma \neq \beta}, \{\mathbf{v}^\beta\}, \boldsymbol{\mu}, \mathbf{m}_F^\alpha) &= \left(Z_{1\text{-loop}}^{\text{vector}}(\mathbf{u}^\alpha) \prod_{\gamma=1}^L Z_{1\text{-loop}}^{\text{vector}}(\mathbf{s}^\gamma) \right) \\ &\times \left(\prod_{j=1}^p Z_{1\text{-loop}}^{\text{fund}}(\mathbf{s}^{\gamma_j}, \mathbf{v}^{\gamma_j}) \prod_{\gamma \neq \beta} Z_{1\text{-loop}}^{\text{fund}}(\mathbf{s}^\gamma, \mathbf{m}^\gamma) Z_{1\text{-loop}}^{\text{hyper}}(\mathbf{u}^\alpha, \mathbf{m}_F^\alpha) \right) \\ &\times \left(\prod_{j=1}^p Z_{1\text{-loop}}^{\text{bif}}(\mathbf{s}^{\gamma_j}, \mathbf{u}^\alpha, -\boldsymbol{\mu}^{\gamma_j}) \prod_{\gamma=1}^{L-1} Z_{1\text{-loop}}^{\text{bif}}(\mathbf{s}^\gamma, \mathbf{s}^{\gamma+1}, 0) \right). \quad (3.46) \end{aligned}$$

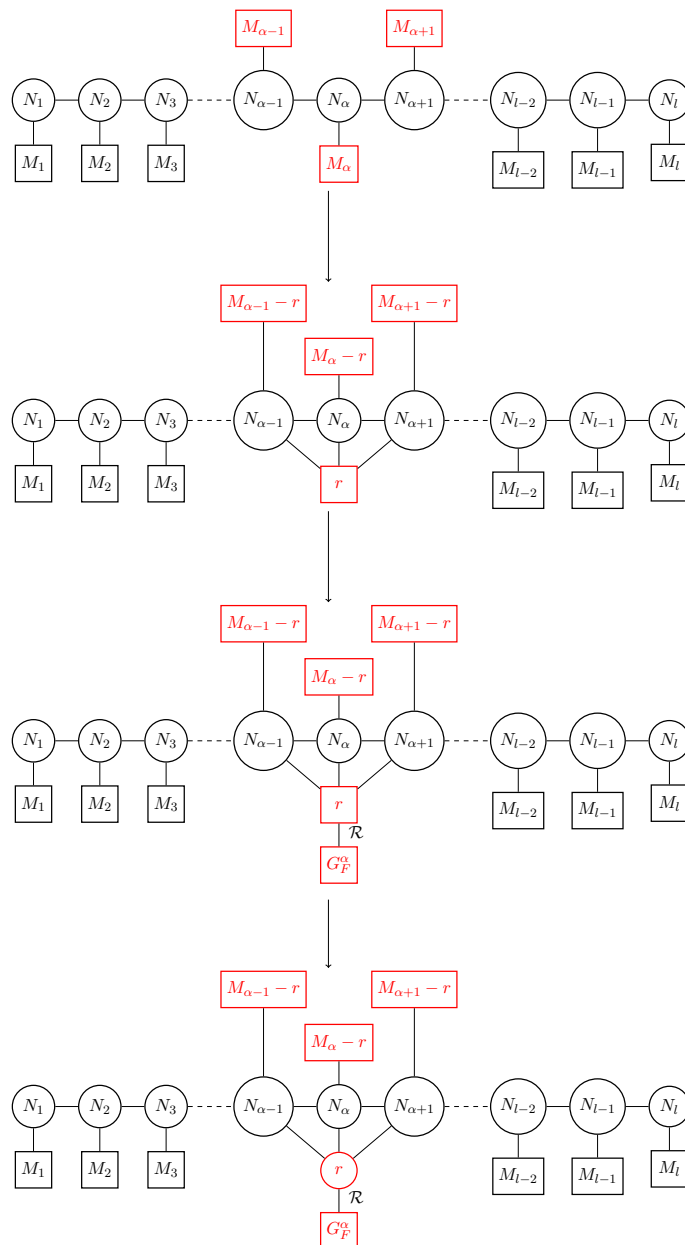

Figure 14. This figure illustrates the identification-gauging $G_{\mathcal{P}}^{\alpha} \circ F_{\mathcal{P}}^{\alpha} \circ I_{\mathcal{P}}^{\alpha}$ operation on a generic linear quiver X involving $p = 3$ nodes labelled by $\beta = \alpha - 1, \alpha, \alpha + 1$.

Similar to the previous examples, the Lagrangian for the theory $G_{\mathcal{P}}^{\alpha} \circ F_{\mathcal{P}}^{\alpha} \circ I_{\mathcal{P}}^{\alpha}(X)$ can now be read off from the integrand of the matrix integral on the r.h.s. of (3.44), and agrees with the quiver gauge theory in the fourth line of figure 14. The parameters μ appear as masses of the hypermultiplets in the bifundamental of $U(M_{\gamma_j}) \times U(r)$, while m_F^{α} are the masses of the hypers transforming in a representation \mathcal{R} of $U(r) \times G_F^{\alpha}$.

3.3 Reading off the dual gauge theory

In the previous section, we have described how new quivers can be constructed from a given linear quiver gauge theory X using the elementary S -type operations. To determine the IR dual of the new quiver, one needs to understand the dual operations acting on the mirror quiver gauge theory Y , as one performs the S -type operation on quiver X . In this section, we will write down a general formula for the partition function of the mirror dual of the theory $\mathcal{O}_{\mathcal{P}}^{\alpha}(X)$ (as defined in (3.22)) in terms of the partition function of Y . We will denote the mirror dual as $\tilde{\mathcal{O}}_{\mathcal{P}}^{\alpha}(Y)$. We will give explicit expressions for the dual partition functions of the four elementary S -type operations discussed in section 3.2. Finally, we will also give a formula for the dual partition function, when the theory X is a generic quiver gauge theory (i.e. not a linear quiver) and has a Lagrangian mirror dual Y .

The properties of linear quivers imply that the partition functions of the mirror pair X and Y are related follows:

$$Z^{(X)}(\mathbf{m}; \mathbf{t}) = e^{2\pi i a^{kl} m_k t_l} Z^{(Y)}(-\mathbf{t}; \mathbf{m}), \quad (3.47)$$

where a^{kl} is an $M \times (L+1)$ matrix with integer entries, $M = \sum_{\alpha=1}^L M_{\alpha}$ and L is the number of nodes in quiver X . Note that $Z^{(X)}$ is convergent since X is a good quiver. Given that X is a good linear quiver, the mirror Y is guaranteed to be a good linear quiver [27], which implies that $Z^{(Y)}$ is also convergent. Therefore, the above equation is well-defined.

The partition function of the theory $(X, \{\mathcal{P}_{\beta}\})$ is given in (3.23). Similarly, the partition function of the mirror dual, which we denote as $(Y, \{\mathcal{P}_{\beta}\})$, is given as

$$Z^{(Y, \{\mathcal{P}_{\beta}\})}(\mathbf{t}; \{\mathbf{u}^{\beta}\}, \{\mathbf{v}^{\beta}\}, \{\mathbf{m}^{\gamma}\}_{\gamma \neq \beta}) := Z^{(Y)}(\mathbf{t}; \{\mathbf{m}^{\beta}(\mathcal{P}_{\beta}, \mathbf{u}^{\beta}, \mathbf{v}^{\beta})\}, \{\mathbf{m}^{\gamma}\}_{\gamma \neq \beta}). \quad (3.48)$$

The mirror symmetry statement (3.47) can be rewritten for the theory $(X, \{\mathcal{P}_{\beta}\})$ and its mirror dual $(Y, \{\mathcal{P}_{\beta}\})$ as follows:

$$Z^{(X, \{\mathcal{P}_{\beta}\})}(\{\mathbf{u}^{\beta}\}, \{\mathbf{v}^{\beta}\}, \{\mathbf{m}^{\gamma}\}_{\gamma \neq \beta}; \mathbf{t}) = e^{2\pi i b_{\beta}^{il} u_i^{\beta} t_l} Z^{(Y, \{\mathcal{P}_{\beta}\})}(-\mathbf{t}; \{\mathbf{u}^{\beta}\}, \{\mathbf{v}^{\beta}\}, \{\mathbf{m}^{\gamma}\}_{\gamma \neq \beta}), \quad (3.49)$$

where for a given $\beta = \gamma_1, \dots, \gamma_p$, b_{β}^{il} is an $r_{\alpha} \times (L+1)$ matrix with integer entries for a given β . In writing the above equality, we have suppressed a phase factor independent of the parameters \mathbf{u}^{α} .

Since Y is a good linear quiver, the function $Z^{(Y, \{\mathcal{P}_{\beta}\})}$ can be written as a matrix integral as follows:

$$\begin{aligned} Z^{(Y, \{\mathcal{P}_{\beta}\})}(\mathbf{t}; \{\mathbf{u}^{\beta}\}, \{\mathbf{v}^{\beta}\}, \{\mathbf{m}^{\gamma}\}_{\gamma \neq \beta}) &= \int \prod_{\gamma'=1}^{L^{\vee}} [d\sigma^{\gamma'}] Z_{\text{int}}^{(Y, \{\mathcal{P}_{\beta}\})}(\{\sigma^{\gamma'}\}, \mathbf{t}, \{\mathbf{u}^{\beta}\}, \{\mathbf{v}^{\beta}\}, \{\mathbf{m}^{\gamma}\}_{\gamma \neq \beta}), \\ Z_{\text{int}}^{(Y, \{\mathcal{P}_{\beta}\})} &= Z_{\text{FI}}^{(Y, \{\mathcal{P}_{\beta}\})}(\{\sigma^{\gamma'}\}, \{\mathbf{u}^{\beta}\}, \{\mathbf{v}^{\beta}\}, \{\mathbf{m}^{\gamma}\}_{\gamma \neq \beta}) \cdot Z_{1\text{-loop}}^{(Y)}(\{\sigma^{\gamma'}\}, \mathbf{t}), \end{aligned} \quad (3.50)$$

where the function $Z_{1\text{-loop}}^{(Y)}$ is independent of $\{\mathbf{u}^{\beta}\}$ and $\{\mathcal{P}_{\beta}\}$, and explicitly given as

$$Z_{1\text{-loop}}^{(Y)}(\{\sigma^{\gamma'}\}, \mathbf{t}) = \prod_{\gamma'=1}^{L^{\vee}} Z_{1\text{-loop}}^{\text{vector}}(\sigma^{\gamma'}) Z_{1\text{-loop}}^{\text{fund}}(\sigma^{\gamma'}, \mathbf{t}) \prod_{\gamma'=1}^{L^{\vee}-1} Z_{1\text{-loop}}^{\text{bif}}(\sigma^{\gamma'}, \sigma^{\gamma'+1}, 0). \quad (3.51)$$

The $\{\mathbf{u}^\beta\}$ -dependent FI term, which also depends on $\{\mathcal{P}_\beta\}$, can be written in the following fashion:

$$\begin{aligned} Z_{\text{FI}}^{(Y, \{\mathcal{P}_\beta\})}(\{\boldsymbol{\sigma}^{\gamma'}\}, \{\mathbf{u}^\beta\}, \{\mathbf{v}^\beta\}, \{\mathbf{m}^\gamma\}_{\gamma \neq \beta}) &= Z_{\text{FI}}^{(Y)}(\{\boldsymbol{\sigma}^{\gamma'}\}, \{\mathbf{m}^\beta(\mathcal{P}_\beta, \mathbf{u}^\beta, \mathbf{v}^\beta)\}, \{\mathbf{m}^\gamma\}_{\gamma \neq \beta}) \\ &= \left(\prod_{\beta} e^{2\pi i g_{\beta}^i(\{\boldsymbol{\sigma}^{\gamma'}\}, \mathcal{P}_\beta) u_i^\beta} \right) \cdot Z_{\text{FI}}^{(Y, \{\mathcal{P}_\beta\})}(\{\boldsymbol{\sigma}^{\gamma'}\}, \{\mathbf{u}^\beta = 0\}, \{\mathbf{v}^\beta\}, \{\mathbf{m}^\gamma\}_{\gamma \neq \beta}), \end{aligned} \quad (3.52)$$

where for the second equality, we have isolated the $\{\mathbf{u}^\beta\}$ -dependent part. Given that the function $Z_{\text{FI}}^{(Y)}(\{\boldsymbol{\sigma}^{\gamma'}\}, \{\mathbf{m}^\gamma\})$ is precisely known for any linear quiver Y (and given in (2.30)), we can explicitly write down the functions $g_{\beta}^i(\{\boldsymbol{\sigma}^{\gamma'}\}, \mathcal{P}_\beta)$:

$$\begin{aligned} g_{\beta}^i(\{\boldsymbol{\sigma}^{\gamma'}\}, \mathcal{P}_\beta) &= -\text{Tr} \sigma^{M_1 + \dots + M_{\beta-1}} \mathcal{P}_{\beta 1 i} + \sum_{i_{\beta}=1}^{M_{\beta}-1} \text{Tr} \sigma^{M_1 + \dots + M_{\beta-1} + i_{\beta}} (\mathcal{P}_{\beta i_{\beta} i} - \mathcal{P}_{\beta (i_{\beta}+1) i}) \\ &\quad + \text{Tr} \sigma^{M_1 + \dots + M_{\beta-1} + M_{\beta}} \mathcal{P}_{\beta M_{\beta} i} \\ &= \sum_{i_{\beta}=1}^{M_{\beta}} \mathcal{P}_{\beta i_{\beta} i} (-\text{Tr} \sigma^{M_1 + \dots + M_{\beta-1} + i_{\beta} - 1} + \text{Tr} \sigma^{M_1 + \dots + M_{\beta-1} + i_{\beta}}) \\ &= (-\text{Tr} \sigma^{M_1 + \dots + M_{\beta-1} + j - 1} + \text{Tr} \sigma^{M_1 + \dots + M_{\beta-1} + j}) \end{aligned} \quad (3.53)$$

where $\mathcal{P}_{\beta i_{\beta} i} = 1$ for some $i_{\beta} = j$ and a fixed i , and vanishes otherwise. The relation is subject to the boundary conditions $\text{Tr} \sigma^{M_0} = \text{Tr} \sigma^{M_1 + \dots + M_{\alpha}} = 0$. Now, let $\tilde{\mathcal{O}}_{\mathcal{P}}^{\alpha}(Y)$ denote the mirror dual of the theory $\mathcal{O}_{\mathcal{P}}^{\alpha}(X)$. The IR duality, along with the fact that both $\mathcal{O}_{\mathcal{P}}^{\alpha}(X)$ and $\tilde{\mathcal{O}}_{\mathcal{P}}^{\alpha}(Y)$ are assumed to be good theories, will imply that their partition functions are related as

$$Z_{\mathcal{P}}^{\mathcal{O}_{\mathcal{P}}^{\alpha}(X)}(\mathbf{m}; \boldsymbol{\eta}) = Z_{\tilde{\mathcal{P}}}^{\tilde{\mathcal{O}}_{\mathcal{P}}^{\alpha}(Y)}(\mathbf{m}'(\boldsymbol{\eta}); \boldsymbol{\eta}'(\mathbf{m})), \quad (3.54)$$

up to some phase factor, where $(\mathbf{m}, \boldsymbol{\eta})$ and $(\mathbf{m}', \boldsymbol{\eta}')$ collectively denote the $\mathcal{N} = 4$ preserving masses and FI parameters of $\mathcal{O}_{\mathcal{P}}^{\alpha}(X)$ and $\tilde{\mathcal{O}}_{\mathcal{P}}^{\alpha}(Y)$ respectively.

Using (3.22), the mirror symmetry relation (3.49), and the equations (3.50)–(3.52), in (3.54) above, the partition function of the theory $\tilde{\mathcal{O}}_{\mathcal{P}}^{\alpha}(Y)$ can be written in the following fashion:

$$\begin{aligned} Z_{\tilde{\mathcal{P}}}^{\tilde{\mathcal{O}}_{\mathcal{P}}^{\alpha}(Y)}(\mathbf{m}'(\mathbf{t}, \eta_{\alpha}); \boldsymbol{\eta}'(\{\mathbf{v}^\beta\}, \{\mathbf{m}^\gamma\}_{\gamma \neq \beta}, \mathbf{m}^{\mathcal{O}_{\mathcal{P}}})) & \quad (3.55) \\ &= \int \prod_{\gamma'=1}^{L_{\vee}} [d\boldsymbol{\sigma}^{\gamma'}] \mathcal{Z}_{\tilde{\mathcal{O}}_{\mathcal{P}}^{\alpha}(Y)}(\{\boldsymbol{\sigma}^{\gamma'}\}, \mathbf{m}^{\mathcal{O}_{\mathcal{P}}}, \eta_{\alpha}, \mathbf{t}) \cdot Z_{\text{int}}^{(Y, \{\mathcal{P}_\beta\})}(\{\boldsymbol{\sigma}^{\gamma'}\}, -\mathbf{t}, \{\mathbf{u}^\beta = 0\}, \{\mathbf{v}^\beta\}, \{\mathbf{m}^\gamma\}_{\gamma \neq \beta}), \end{aligned}$$

where the function $Z_{\text{int}}^{(Y, \{\mathcal{P}_\beta\})}$ is given in (3.50). The function $\mathcal{Z}_{\tilde{\mathcal{O}}_{\mathcal{P}}^{\alpha}(Y)}$ can be explicitly written (as a formal Fourier transform) in terms of the operator $\mathcal{Z}_{\mathcal{O}_{\mathcal{P}}^{\alpha}(X)}$ that appears in (3.22):

$$\mathcal{Z}_{\tilde{\mathcal{O}}_{\mathcal{P}}^{\alpha}(Y)} = \int [d\mathbf{u}^{\alpha}] \mathcal{Z}_{\mathcal{O}_{\mathcal{P}}^{\alpha}(X)}(\mathbf{u}^{\alpha}, \{\mathbf{u}^\beta\}, \eta_{\alpha}, \mathbf{m}^{\mathcal{O}_{\mathcal{P}}}) \prod_{\beta} e^{2\pi i (g_{\beta}^i(\{\boldsymbol{\sigma}^{\gamma'}\}, \mathcal{P}_\beta) + b_{\beta}^i t_i) u_i^{\beta}}. \quad (3.56)$$

We shall take (3.55)–(3.56) as the working definition of the dual operation $\tilde{\mathcal{O}}_{\mathcal{P}}^{\alpha}$ on quiver Y . Given the expression for $Z_{\text{int}}^{(Y, \{\mathcal{P}_\beta\})}$ in (3.50), and the expression for $\mathcal{Z}_{\tilde{\mathcal{O}}_{\mathcal{P}}^{\alpha}(Y)}$ computed

above, the goal is to rewrite the r.h.s. of (3.55) in the standard form of (2.14). Of course, this is only possible if the theory $\tilde{\mathcal{O}}_{\mathcal{P}}^{\alpha}(Y)$ is Lagrangian. From the standard form, the gauge group and the matter content of the theory $\tilde{\mathcal{O}}_{\mathcal{P}}^{\alpha}(Y)$ can then be simply read off. In addition, the precise form of the linear functions $\mathbf{m}'(\mathbf{t}, \eta_{\alpha})$ and $\boldsymbol{\eta}'(\{\mathbf{v}^{\beta}\}, \{\mathbf{m}^{\gamma}\}_{\gamma \neq \beta}, \mathbf{m}^{\mathcal{O}_{\mathcal{P}}})$ can also be read off from the standard form of the partition function.

Note that the integrand of the partition function of the dual theory $\tilde{\mathcal{O}}_{\mathcal{P}}(Y)$ explicitly depends on the permutation matrix \mathcal{P} , even though the partition function itself is independent of it. Therefore, the Lagrangian description of the theory $\tilde{\mathcal{O}}_{\mathcal{P}}(Y)$ depends on \mathcal{P} . If the theory $\tilde{\mathcal{O}}_{\mathcal{P}}(Y)$ can be written as a Lagrangian theory for more than one \mathcal{P} (and they are not related by some trivial change of variables), then all such Lagrangians are conjectured to be IR dual among themselves.

Given the general expression (3.55), we can write down explicitly the dual partition functions for the four types of elementary S -type operations discussed in section 3.2 — gauging, flavoring-gauging, identification-gauging, and flavoring-identification-gauging. The appropriate expressions for $\mathcal{Z}_{\mathcal{O}_{\mathcal{P}}^{\alpha}(X)}(\mathbf{u}^{\alpha}, \{\mathbf{u}^{\beta}\}, \eta_{\alpha}, \mathbf{m}^{\mathcal{O}_{\mathcal{P}}^{\alpha}})$ are given in (3.4), (3.31), (3.37) and (3.43) respectively.

We end this subsection by writing a formula for the dual partition function when an elementary S -type operation $\mathcal{O}_{\mathcal{P}}^{\alpha}$ acts on a generic quiver X in class \mathcal{U} , as discussed in (3.16), when no defect is turned on. This is only possible if the quiver X has a Lagrangian mirror dual Y . The mirror symmetry relation between X and Y can be written as:

$$\mathcal{Z}^{(X, \{\mathcal{P}_{\beta}\})}(\{\mathbf{u}^{\beta}\}, \{\mathbf{v}^{\beta}\}, \dots; \boldsymbol{\eta}) = e^{2\pi i b_{\beta}^i u_i^{\beta} \eta_i} \mathcal{Z}^{(Y, \{\mathcal{P}_{\beta}\})}(\mathbf{m}^Y(\boldsymbol{\eta}); \boldsymbol{\eta}^Y(\{\mathbf{u}^{\beta}\}, \{\mathbf{v}^{\beta}\}, \dots)), \quad (3.57)$$

where $\boldsymbol{\eta}$ collectively denotes the FI parameters of X , and the ... in the argument of $\mathcal{Z}^{(X, \{\mathcal{P}_{\beta}\})}$ denote the other masses of X . The masses and the FI parameters of Y are collectively denoted as $(\mathbf{m}^Y, \boldsymbol{\eta}^Y)$. The partition function of $(Y, \{\mathcal{P}_{\beta}\})$ (being a Lagrangian theory) can again be written as

$$\begin{aligned} & \mathcal{Z}^{(Y, \{\mathcal{P}_{\beta}\})}(\mathbf{m}^Y(\boldsymbol{\eta}); \boldsymbol{\eta}^Y(\{\mathbf{u}^{\beta}\}, \{\mathbf{v}^{\beta}\}, \dots)) \\ &= \int \prod_{\gamma'} [d\boldsymbol{\sigma}^{\gamma'}] \prod_{\beta} e^{2\pi i g_{\beta}^i(\{\boldsymbol{\sigma}^{\gamma'}\}, \mathcal{P}_{\beta}) u_i^{\beta}} \mathcal{Z}_{\text{int}}^{(Y, \{\mathcal{P}_{\beta}\})}(\{\boldsymbol{\sigma}^{\gamma'}\}, \mathbf{m}^Y(\boldsymbol{\eta}), \boldsymbol{\eta}^Y(\{\mathbf{u}^{\beta} = 0\}, \{\mathbf{v}^{\beta}\}, \dots)), \end{aligned} \quad (3.58)$$

where γ' labels the gauge nodes of the theory Y . Note that the functions $g_{\beta}^i(\{\boldsymbol{\sigma}^{\gamma'}\}, \mathcal{P}_{\beta})$ are not known a priori since X, Y are not linear quivers, but have to be provided as additional data about the duality. In cases where X, Y appear as intermediate dual pairs in our construction of a given dual pair starting from linear quivers, these functions are known by construction.

Proceeding in the same fashion as we did for the linear quiver case, the formula for the partition function of the theory $\tilde{\mathcal{O}}_{\mathcal{P}}^{\alpha}(Y)$ can be written as:

$$\begin{aligned} & \mathcal{Z}_{\tilde{\mathcal{O}}_{\mathcal{P}}^{\alpha}(Y)}(\mathbf{m}'(\boldsymbol{\eta}, \eta_{\alpha}); \boldsymbol{\eta}'(\{\mathbf{v}^{\beta}\}, \dots, \mathbf{m}^{\mathcal{O}_{\mathcal{P}}})) \\ &= \int \prod_{\gamma'} [d\boldsymbol{\sigma}^{\gamma'}] \mathcal{Z}_{\tilde{\mathcal{O}}_{\mathcal{P}}^{\alpha}(Y)}(\{\boldsymbol{\sigma}^{\gamma'}\}, \mathbf{m}^{\mathcal{O}_{\mathcal{P}}}, \eta_{\alpha}, \boldsymbol{\eta}) \cdot \mathcal{Z}_{\text{int}}^{(Y, \{\mathcal{P}_{\beta}\})}(\{\boldsymbol{\sigma}^{\gamma'}\}, \mathbf{m}^Y(\boldsymbol{\eta}), \boldsymbol{\eta}^Y(\{\mathbf{u}^{\beta} = 0\}, \{\mathbf{v}^{\beta}\}, \dots)), \end{aligned} \quad (3.59)$$

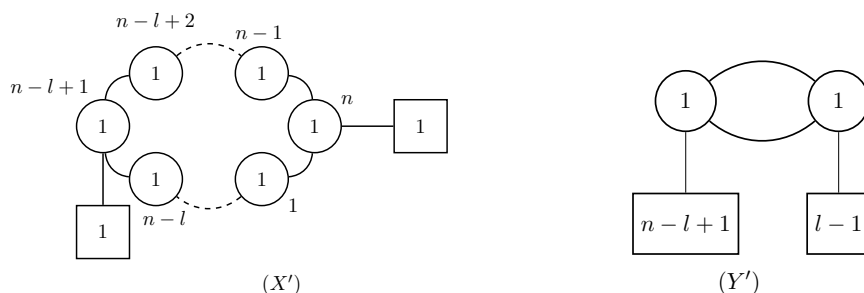

Figure 15. \widehat{A}_{n-1} quiver X' with two fundamental hypermultiplets, and its mirror Y' which is an \widehat{A}_1 quiver with a total of n fundamental hypers.

where the function $Z_{\text{int}}^{(Y, \{\mathcal{P}_\beta\})}$ is given in (3.58), and $(\mathbf{m}', \boldsymbol{\eta}')$ collectively denote the masses and FI parameters of the theory $\widetilde{\mathcal{O}}_{\mathcal{P}}^\alpha(Y)$. The operator $\mathcal{Z}_{\widetilde{\mathcal{O}}_{\mathcal{P}}^\alpha(Y)}$ can be explicitly written (as a formal Fourier transform) in terms the operator $\mathcal{Z}_{\mathcal{O}_{\mathcal{P}}^\alpha(X)}$ that appears in (3.16):

$$\mathcal{Z}_{\widetilde{\mathcal{O}}_{\mathcal{P}}^\alpha(Y)} = \int [du^\alpha] \mathcal{Z}_{\mathcal{O}_{\mathcal{P}}^\alpha(X)}(\mathbf{u}^\alpha, \{\mathbf{u}^\beta\}, \eta_\alpha, \mathbf{m}^{\mathcal{O}_{\mathcal{P}}^\alpha}) \cdot \prod_{\beta} e^{2\pi i (g_{\beta}^i(\{\boldsymbol{\sigma}^{\gamma'}\}, \mathcal{P}_\beta) + b_{\beta}^{il} \eta_l) u_i^{\beta}}, \quad (3.60)$$

where $g_{\beta}^i(\{\boldsymbol{\sigma}^{\gamma'}\}, \mathcal{P}_\beta)$ is a function linear in the variables $\{\boldsymbol{\sigma}^{\gamma'}\}$, and can be read off from the mirror map relating mass parameters of X and FI parameters of Y .

3.4 Simple illustrative example: flavored \widehat{A}_{n-1} quiver

In this section, we present a simple illustrative example of an Abelian mirror dual pair that can be constructed from a dual pair of Abelian linear quivers, following the general recipe given in section 3.2 and section 3.3. The former dual pair, shown in figure 15, are affine A -type quiver gauge theories (circular quivers) with some flavors, and are known to have simple Type IIB descriptions.

The quiver pair (X', Y') in figure 15 can be obtained from a linear dual pair (X, Y) by a single elementary S -type operation $\mathcal{O} = (G \circ F \circ I)$ on X and the dual operation $\widetilde{\mathcal{O}}$ on Y , as shown in figure 16.⁹ The flavor nodes of X (marked in red) on which \mathcal{O} acts, correspond to $U(1)$ flavor symmetries, and therefore the permutation matrix \mathcal{P} is trivial in this case. The dual operation in this case is particularly simple — it amounts to adding a single bifundamental hyper to the linear quiver Y . We will derive this fact using the S^3 partition function,¹⁰ following the general formulae for the dual partition function derived in section 3.3. The purpose of this exercise is to demonstrate how the computation works for the simple example under consideration. Therefore, we will be very detailed in our presentation.

The S^3 partition function for linear quivers and their mirror dual was discussed in section 2.4. Following the notation in (2.27), the partition function of the linear quiver X

⁹In this example and subsequent ones, we drop the superscript α from the notation $\mathcal{O}_{\mathcal{P}}^\alpha$, when there is no ambiguity regarding the flavor node on which the S -type operation acts. In cases where \mathcal{P} is trivial, we drop the subscript as well.

¹⁰The same fact will be derived using the superconformal index in appendix C.3.

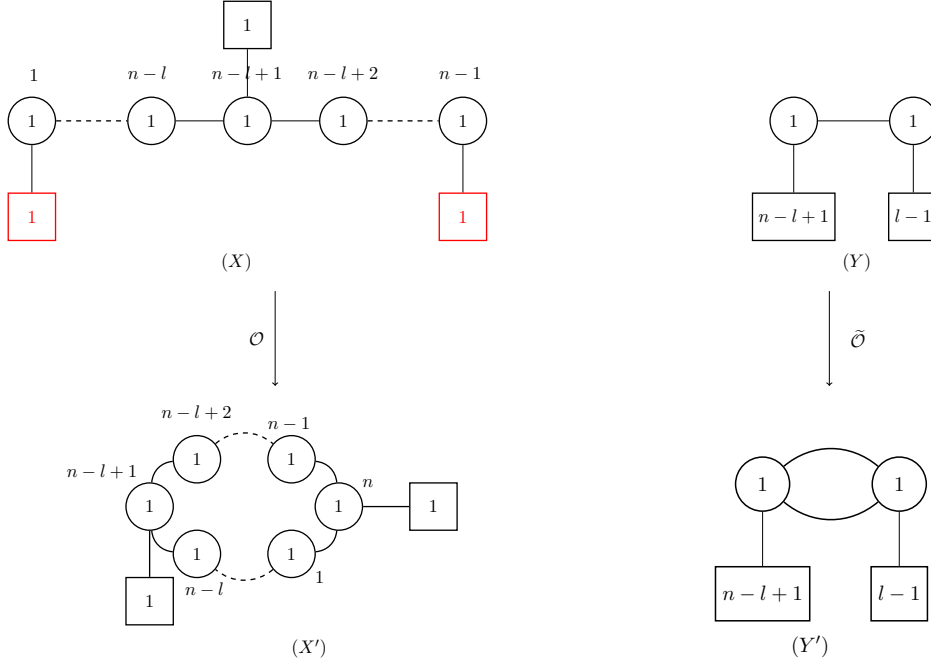

Figure 16. The quiver (X') and its mirror dual (Y') are generated by an elementary S-type operation $\mathcal{O} = G \circ F \circ I$ of the identification-flavoring-gauging type on the linear quiver X and the dual operation $\tilde{\mathcal{O}}$ on the linear quiver Y . The flavor nodes on which \mathcal{O} acts are shown in red on the first line. The dual operation simply involves adding a single bifundamental hyper in the quiver Y .

is given as

$$\begin{aligned}
 Z^{(X)}(\mathbf{m}; \mathbf{t}) &= \int \prod_{\gamma=1}^{n-1} [ds^\gamma] Z_{\text{int}}^{(X)}(\{s^\gamma\}, \mathbf{m}, \mathbf{t}) = \int \prod_{\gamma=1}^{n-1} [ds^\gamma] Z_{\text{FI}}^{(X)}(\{s^\gamma\}, \mathbf{t}) Z_{1\text{-loop}}^{(X)}(\{s^\gamma\}, \mathbf{m}) \\
 &= \int \prod_{\gamma=1}^{n-1} [ds^\gamma] Z_{\text{FI}}^{(X)}(\{s^\gamma\}, \mathbf{t}) Z_{1\text{-loop}}^{\text{fund}}(s^1, m_1) Z_{1\text{-loop}}^{\text{fund}}(s^{n-l+1}, m_2) Z_{1\text{-loop}}^{\text{fund}}(s^{n-1}, m_3) \\
 &\quad \times \prod_{\gamma=1}^{n-2} Z_{1\text{-loop}}^{\text{bif}}(s^\gamma, s^{\gamma+1}, 0), \tag{3.61}
 \end{aligned}$$

where $Z_{\text{FI}}^{(X)}$ and the one-loop factors are given in (2.28). The Higgs branch global symmetry of X is given by $G_H^X = \text{U}(1)^3/\text{U}(1) = \text{U}(1) \times \text{U}(1)$, where the quotient by the overall $\text{U}(1)$ factor in the flavor symmetry of quiver X can be implemented by the constraint $m_2 = 0$. The $\text{U}(1) \times \text{U}(1)$ flavor symmetry of X can then be identified with the two terminal $\text{U}(1)$ flavor nodes, parametrized by the masses (m_1, m_3) . Following the general recipe in section 3.2, let us define:

$$u^1 = m_1, u^2 = m_3. \tag{3.62}$$

From the general formula in (3.42), the partition function of the theory $\mathcal{O}(X)$ is

$$Z^{\mathcal{O}(X)}(\boldsymbol{\mu}, \mathbf{m}_F^\alpha; \mathbf{t}, \eta_\alpha) = \int du^\alpha \mathcal{Z}_{\mathcal{O}(X)}(u^\alpha, u^1, u^2, \eta_\alpha, \boldsymbol{\mu}, \mathbf{m}_F^\alpha) Z^{(X)}(u^1, u^2; \mathbf{t}), \tag{3.63}$$

where $\mathcal{O} = G \circ F \circ I$ is the S -type operation shown in figure 16. The operator $\mathcal{Z}_{\mathcal{O}(X)}$ assumes the following form in this case:

$$\begin{aligned} \mathcal{Z}_{\mathcal{O}(X)}(u^\alpha, u^1, u^2, \eta_\alpha, \boldsymbol{\mu}, m_F^\alpha) &= Z_{\text{FI}}(u^\alpha, \eta_\alpha) Z_{1\text{-loop}}^{\text{hyper}}(u^\alpha, m_F^\alpha) \int du^1 du^2 \prod_{\beta=1}^2 \delta(u^\alpha - u^\beta + \mu^\beta) \\ &= \frac{e^{2\pi i \eta_\alpha u^\alpha}}{\cosh \pi(u^\alpha - m_F^\alpha)} \int du^1 du^2 \prod_{\beta=1}^2 \delta(u^\alpha - u^\beta + \mu^\beta). \end{aligned} \quad (3.64)$$

Using (3.63)–(3.64), and performing the integration over u^β , it trivially follows that:

$$Z^{\mathcal{O}(X)}(\boldsymbol{\mu}, \mathbf{m}_F^\alpha; \mathbf{t}, \eta_\alpha) = Z^{(X')}(\boldsymbol{\mu}, \mathbf{m}_F^\alpha; \mathbf{t}, \eta_\alpha), \quad (3.65)$$

where the quiver X' is given in figure 15. Shifting the integration variable $u^\alpha \rightarrow u^\alpha - \mu^1$, and redefining the mass parameter $m_F^\alpha \rightarrow m_F^\alpha - \mu^1$, one can show that $Z^{(X')}$ only depends on the parameters $\mu = \mu^2 - \mu^1$ and m_F^α . The parameter μ is the mass associated with one of the bifundamental hypers in the loop, while m_F^α is the mass of the new fundamental hyper. The parameters (μ, m_F^α) parametrize the Cartan subalgebra of the $U(1) \times U(1)$ flavor symmetry of X' .

Now, let us compute the dual partition function. Following (2.29), the partition function of the quiver Y is given as

$$\begin{aligned} Z^{(Y)}(\mathbf{t}; \mathbf{m}) &= \int \prod_{\gamma'=1}^2 [d\sigma^{\gamma'}] Z_{\text{int}}^{(Y)}(\{\sigma^{\gamma'}\}, \mathbf{t}, \mathbf{m}) = \int \prod_{\gamma'=1}^2 [d\sigma^{\gamma'}] Z_{\text{FI}}^{(Y)}(\{\sigma^{\gamma'}\}, \mathbf{m}) Z_{1\text{-loop}}^{(Y)}(\{\sigma^{\gamma'}\}, \mathbf{t}) \\ &= \int \prod_{\gamma'=1}^2 [d\sigma^{\gamma'}] Z_{\text{FI}}^{(Y)}(\{\sigma^{\gamma'}\}, \mathbf{m}) \prod_{i=1}^{n-l+1} Z_{1\text{-loop}}^{\text{fund}}(\sigma^1, t_i) \\ &\quad \times \prod_{j=1}^{l-1} Z_{1\text{-loop}}^{\text{fund}}(\sigma^2, t_{n-l+1+j}) Z_{1\text{-loop}}^{\text{bif}}(\sigma^1, \sigma^2, 0), \end{aligned} \quad (3.66)$$

where $Z_{\text{FI}}^{(Y)}$ and the one-loop factors are given in (2.30). In particular, the FI term $Z_{\text{FI}}^{(Y)}$ can be explicitly written as

$$Z_{\text{FI}}^{(Y)}(\{\sigma^{\gamma'}\}, \mathbf{m}) = e^{2\pi i(m_1 - m_2)\sigma^1} e^{2\pi i(m_2 - m_3)\sigma^2}, \quad \implies Z_{\text{FI}}^{(Y)}(\{\sigma^{\gamma'}\}, \mathbf{u}) = e^{2\pi i u^1 \sigma^1} e^{-2\pi i u^2 \sigma^2}. \quad (3.67)$$

Mirror symmetry implies that the partition functions of X and Y are related in the following fashion:

$$\begin{aligned} Z^{(X)}(\mathbf{m}; \mathbf{t}) &= e^{2\pi i t_1 m_1} e^{-2\pi i t_n m_3} Z^{(Y)}(-\mathbf{t}; \mathbf{m}), \\ \implies Z^{(X)}(\mathbf{u}; \mathbf{t}) &= e^{2\pi i b_\beta^l u^\beta t_l} Z^{(Y)}(-\mathbf{t}; \mathbf{u}) = e^{2\pi i t_1 u^1} e^{-2\pi i t_n u^2} Z^{(Y)}(-\mathbf{t}; \mathbf{u}). \end{aligned} \quad (3.68)$$

Using the general formula (3.56), the function $\mathcal{Z}_{\tilde{\mathcal{O}}(Y)}$ is given by the expression:

$$\mathcal{Z}_{\tilde{\mathcal{O}}(Y)}(\sigma^1, \sigma^2, \eta, \boldsymbol{\mu}, m_F^\alpha) = \int du^\alpha \mathcal{Z}_{\mathcal{O}(X)}(u^\alpha, u^1, u^2, \eta, \boldsymbol{\mu}, m_F^\alpha) e^{2\pi i u^1 \sigma^1} e^{-2\pi i u^2 \sigma^2} e^{2\pi i u^\beta b_\beta^l t_l}, \quad (3.69)$$

where the operator $\mathcal{Z}_{\mathcal{O}(X)}$ is explicitly given in (3.64). To simply the expression on the r.h.s., we first shift the integration variable $u^\alpha \rightarrow u^\alpha - \mu^1$, redefine the mass parameter $m_F^\alpha \rightarrow m_F^\alpha - \mu^1$, and use the identity $\frac{1}{\cosh \pi(u^\alpha - m_F^\alpha)} = \int d\tau \frac{e^{2\pi i \tau (u^\alpha - m_F^\alpha)}}{\cosh \pi \tau}$. Finally, integrating over u^α we obtain (up to some overall phase factor):

$$\begin{aligned} \mathcal{Z}_{\tilde{\mathcal{O}}(Y)}(\sigma^1, \sigma^2, \eta_\alpha, \boldsymbol{\mu}, m_F^\alpha) &= \int d\tau \frac{e^{-2\pi i \mu \sigma^2} e^{-2\pi i \tau m_F^\alpha}}{\cosh \pi \tau} \delta\left(\tau + \eta_\alpha + \sigma^1 - \sigma^2 + \sum_\beta b_\beta^l t_l\right) \\ &= \frac{e^{-2\pi i \mu \sigma^2} e^{2\pi i m_F^\alpha (\sigma^1 - \sigma^2 + \eta_\alpha + \sum_\beta b_\beta^l t_l)}}{\cosh \pi (\sigma^1 - \sigma^2 + \eta_\alpha + \sum_\beta b_\beta^l t_l)} \\ &= e^{-2\pi i \mu \sigma^2} e^{2\pi i m_F^\alpha (\sigma^1 - \sigma^2 + \eta_\alpha + \sum_\beta b_\beta^l t_l)} Z_{1\text{-loop}}^{\text{bif}}\left(\sigma^1, \sigma^2, -\eta_\alpha - \sum_\beta b_\beta^l t_l\right), \end{aligned} \quad (3.70)$$

where $\mu = \mu^2 - \mu^1$. Given the expression of the dual partition function in (3.55), the above form of $\mathcal{Z}_{\tilde{\mathcal{O}}(Y)}$ implies that dual operation $\tilde{\mathcal{O}}$ amounts to adding a bifundamental hyper to the theory Y , along with some phase factors which contribute to the FI terms. The dual partition function can be written as,

$$\begin{aligned} \mathcal{Z}_{\tilde{\mathcal{O}}(Y)}(\mathbf{m}'(\mathbf{t}, \eta_\alpha); \boldsymbol{\eta}'(\mu, m_F^\alpha)) &= \int \prod_{\gamma'=1}^2 [d\sigma^{\gamma'}] Z_{1\text{-loop}}^{\text{bif}}\left(\sigma^1, \sigma^2, -\eta_\alpha - \sum_i b^{il} t_l\right) Z_{\text{int}}^{(Y)}(\{\sigma^{\gamma'}\}, -\mathbf{t}, m_F^\alpha, 0, m_F^\alpha + \mu) \\ &= \int Z_{\text{FI}}^{\tilde{\mathcal{O}}(Y)}(\{\sigma^{\gamma'}\}, \boldsymbol{\eta}') \prod_{i=1}^{n-l+1} Z_{1\text{-loop}}^{\text{fund}}(\sigma^1, m_{\text{fund}i}^1) \prod_{j=1}^{l-1} Z_{1\text{-loop}}^{\text{fund}}(\sigma^2, m_{\text{fund}j}^2) \prod_{k=1}^2 Z_{1\text{-loop}}^{\text{bif}}(\sigma^1, \sigma^2, m_k^{\text{bif}}), \end{aligned} \quad (3.71)$$

where, for the second equality, we have used the expression for $Z_{\text{int}}^{(Y)}$ from (3.66), followed by shifting the integration variables and ignoring some overall phase factors. From the second equality, one can manifestly see that

$$\mathcal{Z}_{\tilde{\mathcal{O}}(Y)}(\mathbf{m}'(\mathbf{t}, \eta_\alpha); \boldsymbol{\eta}'(\mu, m_F^\alpha)) = \int \prod_{\gamma'=1}^2 [d\sigma^{\gamma'}] Z_{\text{FI}}^{(Y')}(\{\sigma^{\gamma'}\}, \boldsymbol{\eta}') Z_{1\text{-loop}}^{(Y')}(\{\sigma^{\gamma'}\}, \mathbf{m}') \quad (3.72)$$

$$= Z^{(Y')}(\mathbf{m}'(\mathbf{t}, \eta); \boldsymbol{\eta}'(\mu, m_F^\alpha)), \quad (3.73)$$

where Y' is the quiver in figure 15. The fundamental and bifundamental masses of Y' are given as linear functions of the FI parameters of X' as:

$$\begin{aligned} m_{\text{fund}i}^1 &= -t_i + \delta_1, & (i = 1, \dots, n-l+1), & \quad \delta_1 = \frac{1}{n-l+1} \sum_{i=1}^{n-l+1} t_i, \\ m_{\text{fund}j}^2 &= -t_{n-l+1+j} + \delta_2, & (j = 1, \dots, l-1), & \quad \delta_2 = \frac{1}{l-1} \sum_{j=1}^{l-1} t_{n-l+1+j}, \\ m_{\text{bif}1}' &= \delta_1 - \delta_2, & m_{\text{bif}2}' &= (\delta_1 - \delta_2) - \left(\eta_\alpha + \sum_\beta b_\beta^l t_l\right). \end{aligned} \quad (3.74)$$

These masses parametrize the Cartan subalgebra of the Higgs branch global symmetry $SU(n-l+1) \times SU(l-1) \times U(2)$ of Y' . The FI parameters of Y' are similarly given in terms of the mass parameters of X' as:

$$\eta'_1 = m_F^\alpha, \quad \eta'_2 = -m_F^\alpha - \mu, \quad (3.75)$$

which parametrize the Cartan of the $U(1) \times U(1)$ Coulomb branch global symmetry for Y' .

Note that reading off the Coulomb branch global symmetry of the quiver X' can be a bit counter-intuitive. Naively, one would guess the $SU(n-l+1) \times SU(l-1)$ factor from the presence of the two unbalanced linear subquivers in X' , consisting of $n-l$ and $l-2$ gauge nodes respectively. However, in this case, the remaining $U(1) \times U(1)$ also gets enhanced to an $U(1) \times SU(2)$. This can be directly seen by computing the character expansion of the Coulomb branch Hilbert Series of X' , as we do in (C.77) in course of our discussion of the superconformal index realization of the S -type operation.

4 Non-ADE mirror duals from Abelian S -type operations

In this section, we study 3d mirror symmetry for several infinite families of quiver gauge theories, starting from linear quivers, using Abelian S -type operations. A Hanany-Witten construction for these quiver gauge theories is not known, and therefore the standard Type IIB description for mirror symmetry is not understood for these cases. Some special cases of these theories have realization as 3d mirrors of certain 4d $\mathcal{N} = 2$ theories of class \mathcal{S} on a circle in the deep IR. We will comment on some of these special cases in section 5.

The quivers studied in this section have the following generic features:

1. **Loops attached to a linear quiver tail:** loops built out of gauge nodes and matter in appropriate representations, such that one or more of the gauge nodes are attached to linear quiver tails.
2. **Loops with multiple edges:** loops built out of gauge nodes and matter, such that one or more pairs of gauge nodes are connected by multiple hypermultiplets transforming in a given representation of the associated gauge groups.

In section 4.1, we present a general discussion of elementary Abelian S -type operations and their duals. In particular, we discuss Abelian versions of the four distinct types of elementary S -type operations discussed in section 3.2. We show that the dual operations for the Abelian case lead to Lagrangian theories, which can be explicitly represented as quiver gauge theories. Using these Abelian operations, we construct families of dual pairs involving Abelian quiver gauge theories with the features outlined above, in section 4.2. Families of dual quiver pairs with non-Abelian gauge groups are discussed next in section 4.3. As outlined in section 3.2, our strategy will be to construct these quiver pairs from a pair of linear quivers by a sequence of several Abelian S -type operations.

4.1 Abelian S -type operations: general discussion

From the general definition (3.15), an elementary Abelian S -type operation $\mathcal{O}_{\mathcal{P}}^{\alpha}$ on a generic quiver X is defined as a combination of flavoring, identification and defect operations at a flavor node α , followed by a *single* Abelian gauging operation, i.e.

$$\mathcal{O}_{\mathcal{P}}^{\alpha}(X) := G_{\mathcal{P}}^{\text{Ab}} \circ (F_{\mathcal{P}}^{\alpha})^{n_3} \circ (I_{\mathcal{P}}^{\alpha})^{n_2} \circ (D_{\mathcal{P}}^{\alpha})^{n_1}(X), \quad (n_i = 0, 1, \forall i), \quad (4.1)$$

where $G_{\mathcal{P}}^{\text{Ab}}$ is an Abelian gauging operation. The partition function of the theory $\mathcal{O}_{\mathcal{P}}^{\alpha}(X)$ can be obtained from the general formula (3.16), while the partition function of the dual theory $\tilde{\mathcal{O}}_{\mathcal{P}}^{\alpha}(Y)$ (assuming that X has a Lagrangian mirror Y) can be obtained from (3.59)–(3.60).

In this section, we will write down explicit formulae for the dual partition functions, for the Abelian version of each distinct type of elementary S -type operations¹¹ (without defects) studied in sections 3.2–3.3. In each case, we will first discuss the action of $\mathcal{O}_{\mathcal{P}}^{\alpha}$ on a generic quiver X , followed by the special case where X is a linear quiver. Using these explicit formulae, we will show that, for any dual pair of quiver gauge theories (X, Y) , the theory X' (obtained via an elementary Abelian S -type operation on X) always has a Lagrangian dual Y' . This naturally leads to the following general result. For any dual pair of quiver gauge theories (X, Y) , and an Abelian S -type operation acting on X , i.e.

$$\mathcal{O}_{(\mathcal{P}_1, \dots, \mathcal{P}_l)}^{(\alpha_1, \dots, \alpha_l)}(X) := \mathcal{O}_{\mathcal{P}_l}^{\alpha_l} \circ \mathcal{O}_{\mathcal{P}_{l-1}}^{\alpha_{l-1}} \circ \dots \circ \mathcal{O}_{\mathcal{P}_2}^{\alpha_2} \circ \mathcal{O}_{\mathcal{P}_1}^{\alpha_1}(X), \quad (4.2)$$

where $\mathcal{O}_{\mathcal{P}_i}^{\alpha_i}$ are elementary Abelian operations, the theory $\mathcal{O}_{(\mathcal{P}_1, \dots, \mathcal{P}_l)}^{(\alpha_1, \dots, \alpha_l)}(X)$ is guaranteed to have a Lagrangian dual. In addition, our construction will allow one to write down the dual Lagrangian explicitly as a quiver gauge theory.

4.1.1 Gauging

For an Abelian gauging operation $G_{\mathcal{P}}^{\alpha}$, the functions $\mathcal{Z}_{G_{\mathcal{P}}^{\alpha}(X)}$ and $\mathcal{Z}_{\tilde{G}_{\mathcal{P}}^{\alpha}(Y)}$, as defined in (3.4) and (3.60) respectively, are given as

$$\mathcal{Z}_{G_{\mathcal{P}}^{\alpha}(X)}(u^{\alpha}, \eta_{\alpha}) = Z_{\text{FI}}(u^{\alpha}, \eta_{\alpha}) = e^{2\pi i \eta_{\alpha} u^{\alpha}}, \quad (4.3)$$

$$\mathcal{Z}_{\tilde{G}_{\mathcal{P}}^{\alpha}(Y)} = \delta\left(\eta_{\alpha} + b_{\alpha}^l \eta_l + g_{\alpha}(\{\sigma^{\gamma'}\}, \mathcal{P})\right), \quad (4.4)$$

where the function $g_{\alpha}(\{\sigma^{\gamma'}\}, \mathcal{P})$ can be read off from the mirror map between masses of X and FI parameters of Y . The dual partition function, following (3.59), is then given as

$$\begin{aligned} \mathcal{Z}_{\tilde{G}_{\mathcal{P}}^{\alpha}(Y)}(\mathbf{m}'(\eta, \eta_{\alpha}); \boldsymbol{\eta}'(v^{\alpha}, \dots)) &= \int \prod_{\gamma'} [d\sigma^{\gamma'}] \delta\left(\eta_{\alpha} + b_{\alpha}^l \eta_l + g_{\alpha}(\{\sigma^{\gamma'}\}, \mathcal{P})\right) \\ &\times Z_{\text{int}}^{(Y, \mathcal{P})}(\{\sigma^{\gamma'}\}, \mathbf{m}^Y(\eta), \boldsymbol{\eta}^Y(u^{\alpha} = 0, v^{\alpha}, \dots)). \end{aligned} \quad (4.5)$$

¹¹We will restrict ourselves to flavoring by hypermultiplets with gauge charge 1.

Linear quivers. If X is a linear quiver, the function $\mathcal{Z}_{G_{\mathcal{P}}^{\alpha}(X)}$ is still given by the above formula. The formula for $\mathcal{Z}_{\tilde{G}_{\mathcal{P}}^{\alpha}(Y)}$ is modified by taking $\eta_l \rightarrow t_l$, and writing the function $g_{\alpha}(\{\sigma^{\gamma'}\}, \mathcal{P})$ explicitly (following (3.53)):

$$\begin{aligned} g_{\alpha}^L(\{\sigma^{\gamma'}\}, \mathcal{P}) &= \sum_{i_{\alpha}=1}^{M_{\alpha}} \mathcal{P}_{i_{\alpha}1} (-\text{Tr}\sigma^{M_1+\dots+M_{\alpha-1}+i_{\alpha}-1} + \text{Tr}\sigma^{M_1+\dots+M_{\alpha-1}+i_{\alpha}}) \\ &= (-\text{Tr}\sigma^{M_1+\dots+M_{\alpha-1}+j-1} + \text{Tr}\sigma^{M_1+\dots+M_{\alpha-1}+j}), \quad 1 \leq j \leq M_{\alpha}, \\ &= -\text{Tr}\sigma^{\alpha'-1} + \text{Tr}\sigma^{\alpha'}, \quad \alpha' = M_1 + \dots + M_{\alpha-1} + j, \end{aligned} \quad (4.6)$$

where $\mathcal{P}_{i_{\alpha}1} = 1$ for a fixed $i_{\alpha} = j$, and vanishes otherwise. The relation is subject to the boundary conditions $\text{Tr}\sigma^{M_0} = \text{Tr}\sigma^{M_1+\dots+M_{\alpha}} = 0$. From the expression (3.55) for a linear quiver (or the general prescription (3.59)), the partition function of the theory $\tilde{G}_{\mathcal{P}}^{\alpha}(Y)$ is given as:

$$\begin{aligned} Z_{\tilde{G}_{\mathcal{P}}^{\alpha}(Y)}(\mathbf{m}'(\mathbf{t}, \eta_{\alpha}); \boldsymbol{\eta}'(\mathbf{v}^{\alpha}, \{\mathbf{m}^{\gamma}\}_{\gamma \neq \alpha})) &= \int \prod_{\gamma'=1}^{L^V} [d\sigma^{\gamma'}] \delta(\eta_{\alpha} + b_{\alpha}^l t_l - \text{Tr}\sigma^{\alpha'-1} + \text{Tr}\sigma^{\alpha'}) \\ &\times Z_{\text{int}}^{(Y, \mathcal{P})}(\{\sigma^{\gamma'}\}, -\mathbf{t}, u^{\alpha} = 0, \mathbf{v}^{\alpha}, \{\mathbf{m}^{\gamma}\}_{\gamma \neq \alpha}). \end{aligned} \quad (4.7)$$

There are a couple of observations from the form of the dual partition function $\tilde{G}_{\mathcal{P}}^{\alpha}(Y)$ in (4.5) and (4.7):

1. The equations give a very clear prescription for the dual of a $U(1)$ gauging operation. The action of the dual operation $\tilde{G}_{\mathcal{P}}^{\alpha}$ on the quiver Y amounts to introducing a delta function in the integrand for the partition function of Y , which removes a single $U(1)$ factor (the function g_{α} specifies which one) from the gauge group. The theory $\tilde{G}_{\mathcal{P}}^{\alpha}(Y)$ is therefore manifestly Lagrangian, and the rank of the gauge group of the theory is less than that of the theory Y by $\Delta_{\text{rank}} = 1$. This is a way of seeing that the dual of the gauging operation amounts to ungauging, i.e. reduction in the rank of the gauge group of Y .
2. The delta function and therefore the integrand of the partition function of the dual theory $\tilde{G}_{\mathcal{P}}^{\alpha}(Y)$ in principle depends on the permutation matrix \mathcal{P} . In other words, the Lagrangian description of the theory $\tilde{G}_{\mathcal{P}}^{\alpha}(Y)$ depends on \mathcal{P} , even though the partition function itself is independent of it. In certain cases, the Lagrangians obtained for different choices of \mathcal{P} may be related by field redefinitions. The distinct Lagrangians obtained for different choices of \mathcal{P} are expected to be IR dual among themselves.¹² We will present explicit examples of this phenomenon in section A, where we study mirror duals of D_4 quiver gauge theories and their affine cousins.

4.1.2 Flavoring-gauging

Consider an elementary S -type operation $\mathcal{O}_{\mathcal{P}}^{\alpha} = G_{\mathcal{P}}^{\alpha} \circ F_{\mathcal{P}}^{\alpha}$ on a generic quiver X , where the global symmetry group $U(M_{\alpha})$ associated with the flavor node α is split into $U(1) \times$

¹²There might be additional subtleties associated with discrete symmetries in establishing these IR dualities which are not captured by the partition function analysis.

$U(M_\alpha - 1)$, and the resulting $U(1)$ node is flavored by N_F^α hypermultiplets of charge 1, followed by a gauging operation. The case for hypermultiplets with a generic charge $Q \neq 1$, or with different charges, can be worked out in an analogous fashion.

The flavor symmetry introduced by the operation $\mathcal{O}_{\mathcal{P}}^\alpha$ is $G_F^\alpha = U(N_F^\alpha)$, and the masses in the Cartan of $U(N_F^\alpha)$ are labelled as $\{m_{kF}^\alpha\}$, where $k = 1, \dots, N_F^\alpha$. The function $\mathcal{Z}_{G_{\mathcal{P}}^\alpha \circ F_{\mathcal{P}}^\alpha(X)}$, which can be read off from (3.4), (3.6) and (3.17), is given as

$$\mathcal{Z}_{G_{\mathcal{P}}^\alpha \circ F_{\mathcal{P}}^\alpha(X)}(u^\alpha, \mathbf{m}_F^\alpha, \eta_\alpha) = Z_{\text{FI}}(u^\alpha, \eta_\alpha) Z_{1\text{-loop}}^{\text{hyper}}(u^\alpha, \mathbf{m}_F^\alpha) = \frac{e^{2\pi i \eta_\alpha u^\alpha}}{\prod_k \cosh \pi(u^\alpha - m_{kF}^\alpha)}. \quad (4.8)$$

In addition, the function $Z_{1\text{-loop}}^{\text{hyper}}(u^\alpha, \mathbf{m}_F^\alpha)$ satisfies a useful integral identity:

$$\begin{aligned} Z_{1\text{-loop}}^{\text{hyper}}(u^\alpha, \mathbf{m}_F^\alpha) &= \frac{1}{\prod_{k=1}^{N_F^\alpha} \cosh \pi(u^\alpha - m_{kF}^\alpha)} \\ &= \int \prod_{k=1}^{N_F^\alpha} d\tau_k^\alpha \frac{e^{2\pi i(u^\alpha - m_{1F}^\alpha)\tau_1^\alpha} \prod_{k=2}^{N_F^\alpha} e^{2\pi i\tau_k^\alpha(m_{k-1F}^\alpha - m_{kF}^\alpha)}}{\prod_{k=1}^{N_F^\alpha - 1} \cosh \pi(\tau_k^\alpha - \tau_{k+1}^\alpha) \cosh \pi\tau_{N_F^\alpha}^\alpha} \\ &= \int \prod_{k=1}^{N_F^\alpha} d\tau_k^\alpha Z_{\text{FI}}(\tau_1^\alpha, (u^\alpha - m_{1F}^\alpha)) \\ &\quad \times \prod_{k=2}^{N_F^\alpha} Z_{\text{FI}}(\tau_k^\alpha, (m_{k-1F}^\alpha - m_{kF}^\alpha)) Z^{\text{fund}}(\tau_{N_F^\alpha}^\alpha, 0) \prod_{k=1}^{N_F^\alpha - 1} Z^{\text{bifund}}(\tau_k^\alpha, \tau_{k+1}^\alpha, 0) \\ &=: \int \prod_{k=1}^{N_F^\alpha} d\tau_k^\alpha Z_{\text{int}}^{\mathcal{T}[N_F^\alpha]}(\boldsymbol{\tau}^\alpha, \mathbf{t}'_\alpha, 0), \end{aligned} \quad (4.9)$$

where $\mathcal{T}[N_F^\alpha]$ is an Abelian linear quiver gauge theory with N_F^α gauge nodes and a single flavor attached to the N_F^α -th gauge node. The FI parameters are parametrized by \mathbf{t}'^α , with $t'_{\alpha 1} = u^\alpha$, $t'_{\alpha k} = m_{k-1F}^\alpha$ for $k = 2, \dots, N_F^\alpha$, and the single mass parameter $m^\alpha = 0$.

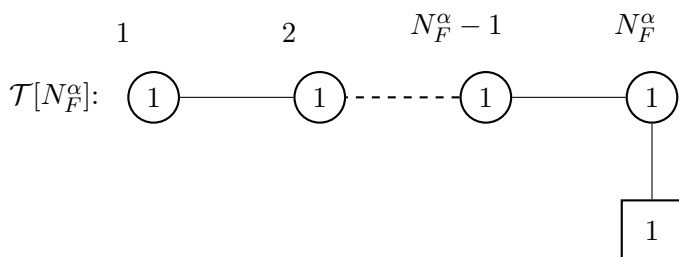

Using the general formula given in (3.60), the function $\mathcal{Z}_{(\widetilde{G_{\mathcal{P}}^\alpha \circ F_{\mathcal{P}}^\alpha}^\alpha)(Y)}$ can be written as

$$\begin{aligned} \mathcal{Z}_{(\widetilde{G_{\mathcal{P}}^\alpha \circ F_{\mathcal{P}}^\alpha}^\alpha)(Y)}(\{\boldsymbol{\sigma}^{\gamma'}\}, \eta_\alpha, \mathbf{m}_F^\alpha, \boldsymbol{\eta}) &= \int du^\alpha \mathcal{Z}_{G_{\mathcal{P}}^\alpha \circ F_{\mathcal{P}}^\alpha(X)}(u^\alpha, \mathbf{m}_F^\alpha, \eta_\alpha) e^{2\pi i(g_\alpha(\{\boldsymbol{\sigma}^{\gamma'}\}, \mathcal{P}) + b_\alpha^l \eta_l) u^\alpha} \\ &= \int \prod_{k=1}^{N_F^\alpha} d\tau_k^\alpha Z_{\text{int}}^{\mathcal{T}[N_F^\alpha]}(\boldsymbol{\tau}^\alpha, \{t'_{\alpha 1} = 0, t'_{\alpha k \neq 1}\}, 0) \delta(\tau_1^\alpha + \eta_\alpha + b_\alpha^l \eta_l + g_\alpha(\{\boldsymbol{\sigma}^{\gamma'}\}, \mathcal{P})). \end{aligned} \quad (4.10)$$

Implementing the delta function and relabelling the integration variables $\tau_k^\alpha \rightarrow \tau_{k-1}^\alpha$, $t'_{\alpha k} \rightarrow t'_{\alpha k-1}$, we can rewrite the above function as

$$\begin{aligned} \mathcal{Z}_{(\widetilde{G_{\mathcal{P}}^\alpha \circ F_{\mathcal{P}}^\alpha})^{(Y)}} &= \int \prod_{k=1}^{N_F^\alpha - 1} d\tau_k^\alpha e^{2\pi i m_{1F}^\alpha g_\alpha(\{\sigma^{\gamma'}\}, \mathcal{P})} Z_{(\widetilde{G_{\mathcal{P}}^\alpha \circ F_{\mathcal{P}}^\alpha})^{(Y)}}^{\text{hyper}} \\ &\times \left(\{\sigma^{\gamma'}\}, \tau_1^\alpha, \eta_\alpha, \boldsymbol{\eta} \right) Z_{\text{int}}^{(\mathcal{T}[N_F^\alpha - 1])}(\boldsymbol{\tau}^\alpha, \mathbf{m}_F^\alpha, 0), \end{aligned} \quad (4.11)$$

$$Z_{(\widetilde{G_{\mathcal{P}}^\alpha \circ F_{\mathcal{P}}^\alpha})^{(Y)}}^{\text{hyper}} \left(\{\sigma^{\gamma'}\}, \tau_1^\alpha, \eta_\alpha, \boldsymbol{\eta} \right) = \frac{1}{\cosh \pi (g_\alpha(\{\sigma^{\gamma'}\}, \mathcal{P}) + \tau_1^\alpha + \eta_\alpha + b_\alpha^\dagger \eta)}. \quad (4.12)$$

Note that $Z_{(\widetilde{G_{\mathcal{P}}^\alpha \circ F_{\mathcal{P}}^\alpha})^{(Y)}}^{\text{hyper}}$ can be interpreted as the 1-loop contribution of a single hypermultiplet charged under $U(1)_1$ of $\mathcal{T}[N_F^\alpha - 1]$ and the various $U(1)$ factors in the gauge group of quiver Y — the precise gauge nodes and the charges can be read off from the function $g_\alpha(\{\sigma^{\gamma'}\}, \mathcal{P})$. Using the prescription (3.59), and the simplified expression for $\mathcal{Z}_{(\widetilde{G_{\mathcal{P}}^\alpha \circ F_{\mathcal{P}}^\alpha})^{(Y)}}$ in (4.11)–(4.12), the dual partition function can be written as (up to some phase factor)

$$\begin{aligned} Z_{(\widetilde{G_{\mathcal{P}}^\alpha \circ F_{\mathcal{P}}^\alpha})^{(Y)}}(\mathbf{m}'(\boldsymbol{\eta}, \eta_\alpha); \boldsymbol{\eta}'(\mathbf{v}^\alpha, \dots, \mathbf{m}_F^\alpha)) &= \int \prod_{\gamma'} [d\sigma^{\gamma'}] \prod_{k=1}^{N_F^\alpha - 1} d\tau_k^\alpha Z_{\text{int}}^{(\mathcal{T}[N_F^\alpha - 1])}(\boldsymbol{\tau}^\alpha, \mathbf{m}_F^\alpha, 0) \\ &\times Z_{(\widetilde{G_{\mathcal{P}}^\alpha \circ F_{\mathcal{P}}^\alpha})^{(Y)}}^{\text{hyper}} \left(\{\sigma^{\gamma'}\}, \tau_1^\alpha, \eta_\alpha, \boldsymbol{\eta} \right) \cdot Z_{\text{int}}^{(Y, \mathcal{P})}(\{\sigma^{\gamma'}\}, \mathbf{m}^Y(\boldsymbol{\eta}), \boldsymbol{\eta}^Y(\mathbf{u}^\alpha = \mathbf{m}_{1F}^\alpha, \mathbf{v}^\alpha, \dots)). \end{aligned} \quad (4.13)$$

The dual theory is manifestly Lagrangian, which can be read off from the integrand in the r.h.s. of the above equation. The theory consists of a $\mathcal{T}[N_F^\alpha - 1]$ tail attached to the quiver Y by a single hypermultiplet, which is also charged under some of the $U(1)$ factors in the gauge group of Y . As a quiver diagram, the theory can be represented as

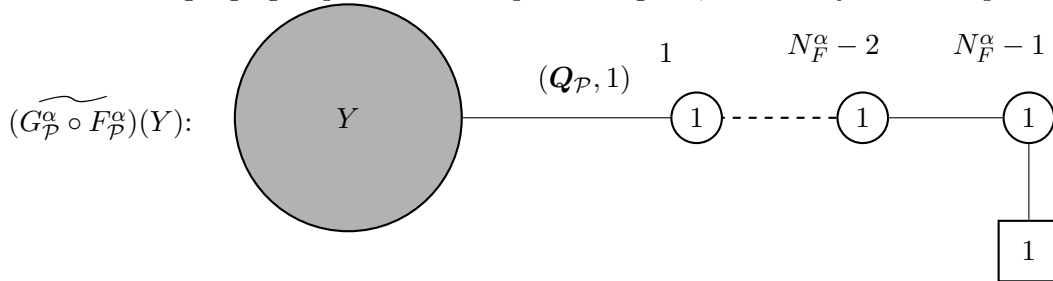

In the above quiver gauge theory, $(\mathbf{Q}_{\mathcal{P}}, 1)$ collectively denotes the charges of the hypermultiplet connecting Y and $\mathcal{T}[N_F^\alpha - 1]$, under various $U(1)$ factors of Y and $U(1)_1$ respectively. There are a couple of observations about the dual theory:

1. The charge vector $\mathbf{Q}_{\mathcal{P}}$, and therefore the precise shape of the quiver, depends on the choice of the permutation matrix \mathcal{P} .
2. In the special case, where $N_F^\alpha = 1$, the function $\mathcal{Z}_{(\widetilde{G_{\mathcal{P}}^\alpha \circ F_{\mathcal{P}}^\alpha})^{(Y)}}$ is given as

$$\begin{aligned} \mathcal{Z}_{(\widetilde{G_{\mathcal{P}}^\alpha \circ F_{\mathcal{P}}^\alpha})^{(Y)}} &= e^{2\pi i m_F^\alpha g_\alpha(\{\sigma^{\gamma'}\}, \mathcal{P})} Z_{(\widetilde{G_{\mathcal{P}}^\alpha \circ F_{\mathcal{P}}^\alpha})^{(Y)}}^{\text{hyper}} \left(\{\sigma^{\gamma'}\}, \eta_\alpha, \boldsymbol{\eta} \right), \\ Z_{(\widetilde{G_{\mathcal{P}}^\alpha \circ F_{\mathcal{P}}^\alpha})^{(Y)}}^{\text{hyper}} \left(\{\sigma^{\gamma'}\}, \eta_\alpha, \boldsymbol{\eta} \right) &= \frac{1}{\cosh \pi (g_\alpha(\{\sigma^{\gamma'}\}, \mathcal{P}) + \eta_\alpha + b_\alpha^\dagger \eta)}. \end{aligned} \quad (4.14)$$

The dual partition function is then given as

$$\begin{aligned} & Z^{(G_{\mathcal{P}}^{\alpha} \circ F_{\mathcal{P}}^{\alpha})(Y)}(\mathbf{m}'(\boldsymbol{\eta}, \eta_{\alpha}); \boldsymbol{\eta}'(\mathbf{v}^{\alpha}, \dots, m_F^{\alpha})) \\ &= \int \prod_{\gamma'} [d\boldsymbol{\sigma}^{\gamma'}] Z_{(G_{\mathcal{P}}^{\alpha} \circ F_{\mathcal{P}}^{\alpha})(Y)}^{\text{hyper}}(\{\boldsymbol{\sigma}^{\gamma'}\}, \eta_{\alpha}, \boldsymbol{\eta}) \cdot Z_{\text{int}}^{(Y, \mathcal{P})}(\{\boldsymbol{\sigma}^{\gamma'}\}, \mathbf{m}^Y(\boldsymbol{\eta}), \boldsymbol{\eta}^Y(\mathbf{u}^{\alpha} = m_F^{\alpha}, \mathbf{v}^{\alpha}, \dots)). \end{aligned} \quad (4.15)$$

The dual theory $(G_{\mathcal{P}}^{\alpha} \circ F_{\mathcal{P}}^{\alpha})(Y)$ then is even simpler. It merely involves introducing an extra hypermultiplet in the quiver gauge theory (Y) , such that the hypermultiplet is charged under a certain $U(1)^r$ subgroup (r is an integer) of the gauge group. Note that the mass parameter m_F^{α} enters the r.h.s. of the above equation as an FI parameter.

Linear quivers. For a linear quiver pair (X, Y) , the function $g_{\alpha} = g_{\alpha}^L$ has the simple form (4.6), while $Z_{(G_{\mathcal{P}}^{\alpha} \circ F_{\mathcal{P}}^{\alpha})(Y)}$ is given by the formulae (4.11)–(4.12). The function $Z_{(G_{\mathcal{P}}^{\alpha} \circ F_{\mathcal{P}}^{\alpha})(Y)}$ can be further simplified after a change of variables, $\tau_k^{\alpha} \rightarrow \tau_k^{\alpha} - \text{Tr} \boldsymbol{\sigma}^{\alpha'}$, and can be written as follows:

$$\begin{aligned} Z_{(G_{\mathcal{P}}^{\alpha} \circ F_{\mathcal{P}}^{\alpha})(Y)} &= \int \prod_{k=1}^{N_F^{\alpha}-1} d\tau_k^{\alpha} e^{-2\pi i m_{1F}^{\alpha} \text{Tr} \boldsymbol{\sigma}^{\alpha'-1}} e^{2\pi i m_{N_F^{\alpha} F}^{\alpha} \text{Tr} \boldsymbol{\sigma}^{\alpha'}} Z_{(N_{\alpha'-1}^{\vee}, 1)}^{\text{hyper}}(\boldsymbol{\sigma}^{\alpha'-1}, \tau_1^{\alpha}, \eta_{\alpha} + b_{\alpha}^l t_l) \\ &\times Z_{\text{int}}^{(\mathcal{T}[N_F^{\alpha}-1])}(\boldsymbol{\tau}^{\alpha}, \mathbf{m}_{F}^{\alpha}, \text{Tr} \boldsymbol{\sigma}^{\alpha'}), \end{aligned} \quad (4.16)$$

where the function $Z_{(N_{\alpha'-1}^{\vee}, 1)}^{\text{hyper}}$ has the explicit form:

$$Z_{(N_{\alpha'-1}^{\vee}, 1)}^{\text{hyper}}(\boldsymbol{\sigma}^{\alpha'-1}, \tau_1^{\alpha}, \eta_{\alpha} + b_{\alpha}^l t_l) = \frac{1}{\cosh \pi(-\text{Tr} \boldsymbol{\sigma}^{\alpha'-1} + \tau_1^{\alpha} + \eta_{\alpha} + b_{\alpha}^l t_l)}. \quad (4.17)$$

The subscript in $Z_{(N_{\alpha'-1}^{\vee}, 1)}^{\text{hyper}}$ denotes the charges of the hypermultiplet under the $U(1)$ subgroup of $U(N_{\alpha'-1}^{\vee})$ and $U(1)_1$ of $\mathcal{T}[N_F^{\alpha}-1]$ respectively. Using the general prescription in (3.59), the dual partition function can be written as

$$\begin{aligned} & Z^{(G_{\mathcal{P}}^{\alpha} \circ F_{\mathcal{P}}^{\alpha})(Y)}(\mathbf{m}'(\mathbf{t}, \eta_{\alpha}); \boldsymbol{\eta}'(\mathbf{v}^{\alpha}, \mathbf{m}_{F}^{\alpha}, \{\mathbf{m}^{\gamma}\}_{\gamma \neq \alpha})) = \int \prod_{\gamma'=1}^{L^{\vee}} [d\boldsymbol{\sigma}^{\gamma'}] \prod_{k=1}^{N_F^{\alpha}-1} d\tau_k^{\alpha} Z_{\text{int}}^{(\mathcal{T}[N_F^{\alpha}-1])}(\boldsymbol{\tau}^{\alpha}, \mathbf{m}_{F}^{\alpha}, \text{Tr} \boldsymbol{\sigma}^{\alpha'}) \\ & \times Z_{(N_{\alpha'-1}^{\vee}, 1)}^{\text{hyper}}(\boldsymbol{\sigma}^{\alpha'-1}, \tau_1^{\alpha}, \eta_{\alpha} + b_{\alpha}^l t_l) Z_{\text{FI}}(\boldsymbol{\sigma}^{\alpha'}, m_{N_F^{\alpha} F}^{\alpha} - m_{1F}^{\alpha}) Z_{\text{int}}^{(Y, \mathcal{P})}(\{\boldsymbol{\sigma}^{\gamma'}\}, -\mathbf{t}, \mathbf{u}^{\alpha} = m_{1F}^{\alpha}, \mathbf{v}^{\alpha}, \{\mathbf{m}^{\gamma}\}_{\gamma \neq \alpha}). \end{aligned} \quad (4.18)$$

Graphically, the dual theory $(G_{\mathcal{P}}^{\alpha} \circ F_{\mathcal{P}}^{\alpha})(Y)$ for a linear quiver Y is given as:

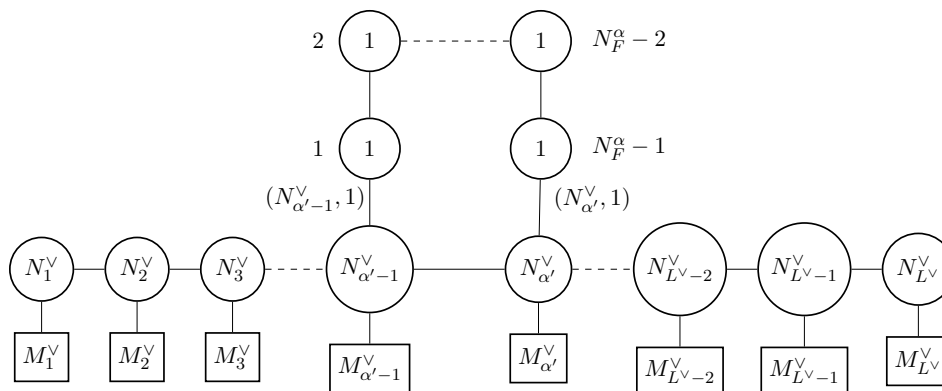

There are a few observations that we can make about this dual theory:

1. The location of the two consecutive nodes at which the Abelian loop is attached depends on the choice of \mathcal{P} .
2. For $N_F^\alpha = 1$, the dual theory has a single hypermultiplet (as opposed to the loop) charged under the $U(1)$ subgroups of $U(N_{\alpha'-1}^\vee) \times U(N_{\alpha'}^\vee)$. The dual partition function can be computed as before:

$$Z^{(G_{\mathcal{P}}^\alpha \circ F_{\mathcal{P}}^\alpha)(Y)}(\mathbf{m}'(\mathbf{t}, \eta_\alpha); \boldsymbol{\eta}'(\mathbf{v}^\alpha, \mathbf{m}_F^\alpha, \{\mathbf{m}^\gamma\}_{\gamma \neq \alpha})) = \int \prod_{\gamma'=1}^{L^\vee} [d\boldsymbol{\sigma}^{\gamma'}] Z_{(N_{\alpha'-1}^\vee, N_{\alpha'}^\vee)}^{\text{hyper}}(\boldsymbol{\sigma}^{\alpha'-1}, \boldsymbol{\sigma}^{\alpha'}, \eta_\alpha, \mathbf{t}) \\ \times Z_{\text{int}}^{(Y, \mathcal{P})}(\{\boldsymbol{\sigma}^{\gamma'}\}, -\mathbf{t}, \mathbf{u}^\alpha = m_F^\alpha, \mathbf{v}^\alpha, \{\mathbf{m}^\gamma\}_{\gamma \neq \alpha}), \quad (4.19)$$

$$Z_{(N_{\alpha'-1}^\vee, N_{\alpha'}^\vee)}^{\text{hyper}}(\{\boldsymbol{\sigma}^{\gamma'}\}, \eta_\alpha, \mathbf{t}) = \frac{1}{\cosh \pi(-\text{Tr} \boldsymbol{\sigma}^{\alpha'-1} + \text{Tr} \boldsymbol{\sigma}^{\alpha'} + \eta_\alpha + b_\alpha^l t_l)}. \quad (4.20)$$

In the special case $N_{\alpha'-1}^\vee = N_{\alpha'}^\vee = 1$, (4.20) simply corresponds to a hypermultiplet in the bifundamental representation of $U(1)_{\alpha'-1} \times U(1)_{\alpha'}$.

The special cases of flavoring-gauging operations with $N^\alpha = 1$, given by (4.14)–(4.15) and (4.19)–(4.20) for a generic quiver and a linear quiver respectively, will be used frequently for the construction of non-ADE mirror duals later in this section.

4.1.3 Identification-gauging

The Abelian identification-gauging operation on a generic quiver X can be worked out in a similar fashion. The operator $\mathcal{Z}_{(G_{\mathcal{P}}^\alpha \circ I_{\mathcal{P}}^\alpha)(X)}$ can be read off from (3.4) and (3.11):

$$\mathcal{Z}_{(G_{\mathcal{P}}^\alpha \circ I_{\mathcal{P}}^\alpha)(X)}(u^\alpha, \{u^\beta\}, \eta_\alpha, \boldsymbol{\mu}) = Z_{\text{FI}}(u^\alpha, \eta_\alpha) \int \prod_{j=1}^p du^{\gamma_j} \delta(u^\alpha - u^{\gamma_j} + \mu^{\gamma_j}), \quad (4.21)$$

where $\beta = \gamma_1, \dots, \gamma_p$. The function $\mathcal{Z}_{(G_{\mathcal{P}}^\alpha \circ I_{\mathcal{P}}^\alpha)(Y)}$, as defined in (3.60), is given as

$$\mathcal{Z}_{(G_{\mathcal{P}}^\alpha \circ I_{\mathcal{P}}^\alpha)(Y)}(\{\boldsymbol{\sigma}^{\gamma'}\}, \eta_\alpha, \boldsymbol{\mu}, \boldsymbol{\eta}) = \int du^\alpha \mathcal{Z}_{(G_{\mathcal{P}}^\alpha \circ I_{\mathcal{P}}^\alpha)(X)}(u^\alpha, \{u^\beta\}, \eta_\alpha, \boldsymbol{\mu}) \prod_{\beta} e^{2\pi i(g_\beta(\{\boldsymbol{\sigma}^{\gamma'}\}, \mathcal{P}_\beta) + b_\beta^l \eta_l) u^\beta}. \quad (4.22)$$

Note that we have dropped the index i , since the operation is Abelian. Implementing the p delta function integrals, and integrating over u^α , we have the following form:

$$\mathcal{Z}_{(G_{\mathcal{P}}^\alpha \circ I_{\mathcal{P}}^\alpha)(Y)}(\{\boldsymbol{\sigma}^{\gamma'}\}, \eta_\alpha, \boldsymbol{\mu}, \boldsymbol{\eta}) = \delta\left(\eta_\alpha + \sum_{\beta} b_\beta^l \eta_l + \sum_{\beta} g_\beta(\{\boldsymbol{\sigma}^{\gamma'}\}, \mathcal{P}_\beta)\right) \prod_{\beta} e^{2\pi i(g_\beta(\{\boldsymbol{\sigma}^{\gamma'}\}, \mathcal{P}_\beta) + b_\beta^l \eta_l) \mu^\beta}. \quad (4.23)$$

From the general prescription (3.59), the partition function of the theory $(G_{\mathcal{P}}^\alpha \circ I_{\mathcal{P}}^\alpha)(Y)$ is given as

$$Z^{(G_{\mathcal{P}}^\alpha \circ I_{\mathcal{P}}^\alpha)(Y)}(\mathbf{m}'(\boldsymbol{\eta}, \eta_\alpha); \boldsymbol{\eta}'(\{\mathbf{v}^\beta\}, \dots)) = \int \prod_{\gamma'} [d\boldsymbol{\sigma}^{\gamma'}] \delta\left(\eta_\alpha + \sum_{\beta} b_\beta^l \eta_l + \sum_{\beta} g_\beta(\{\boldsymbol{\sigma}^{\gamma'}\}, \mathcal{P}_\beta)\right) \\ \times \prod_{\beta} e^{2\pi i(g_\beta(\{\boldsymbol{\sigma}^{\gamma'}\}, \mathcal{P}_\beta) + b_\beta^l \eta_l) \mu^\beta} \cdot Z_{\text{int}}^{(Y, \{\mathcal{P}_\beta\})}(\{\boldsymbol{\sigma}^{\gamma'}\}, \mathbf{m}^Y(\boldsymbol{\eta}), \boldsymbol{\eta}^Y(\{\mathbf{u}^\beta = 0\}, \{\mathbf{v}^\beta\}, \dots)), \quad (4.24)$$

which can be massaged into the following expression:

$$\begin{aligned}
 Z^{(\widetilde{G_{\mathcal{P}}^{\alpha}} \circ I_{\mathcal{P}}^{\alpha})^{(Y)}}(\mathbf{m}'(\boldsymbol{\eta}, \eta_{\alpha}); \boldsymbol{\eta}'(\{\mathbf{v}^{\beta}\}, \dots)) &= \int \prod_{\gamma'} [d\boldsymbol{\sigma}^{\gamma'}] \delta\left(\eta_{\alpha} + \sum_{\beta} b_{\beta}^l \eta_l + \sum_{\beta} g_{\beta}(\{\boldsymbol{\sigma}^{\gamma'}\}, \mathcal{P}_{\beta})\right) \\
 &\times Z_{\text{int}}^{(Y, \{\mathcal{P}_{\beta}\})}(\{\boldsymbol{\sigma}^{\gamma'}\}, \mathbf{m}^Y(\boldsymbol{\eta}), \boldsymbol{\eta}^Y(\{\mathbf{u}^{\beta} = \mu^{\beta}\}, \{\mathbf{v}^{\beta}\}, \dots)).
 \end{aligned} \tag{4.25}$$

Linear quivers. For a linear quiver X , the function $\mathcal{Z}_{(\widetilde{G_{\mathcal{P}}^{\alpha}} \circ I_{\mathcal{P}}^{\alpha})^{(Y)}}$ is obtained from (4.23) by replacing $\eta_l \rightarrow t_l$, and the function $g_{\beta} \rightarrow g_{\beta}^L$, where $g_{\beta}^L(\{\boldsymbol{\sigma}^{\gamma'}\}, \mathcal{P}_{\beta})$ is given as

$$\begin{aligned}
 g_{\beta}^L(\{\boldsymbol{\sigma}^{\gamma'}\}, \mathcal{P}_{\beta}) &= \sum_{i_{\beta}=1}^{M_{\beta}} \mathcal{P}_{\beta i_{\beta} 1} (-\text{Tr} \boldsymbol{\sigma}^{M_1 + \dots + M_{\beta-1} + i_{\beta} - 1} + \text{Tr} \boldsymbol{\sigma}^{M_1 + \dots + M_{\beta-1} + i_{\beta}}) \\
 &= -\text{Tr} \boldsymbol{\sigma}^{M_1 + \dots + M_{\beta-1} + j_{\beta} - 1} + \text{Tr} \boldsymbol{\sigma}^{M_1 + \dots + M_{\beta-1} + j_{\beta}}, \quad 1 \leq j_{\beta} \leq M_{\beta} \\
 &= -\text{Tr} \boldsymbol{\sigma}^{\alpha'_{\beta} - 1} + \text{Tr} \boldsymbol{\sigma}^{\alpha'_{\beta}}, \quad \alpha'_{\beta} = M_1 + \dots + M_{\beta-1} + j_{\beta}.
 \end{aligned} \tag{4.26}$$

From the expression (3.55) for a linear quiver (or the more general prescription (3.59)), the partition function of the theory $(\widetilde{G_{\mathcal{P}}^{\alpha}} \circ I_{\mathcal{P}}^{\alpha})^{(Y)}$ is then given as

$$\begin{aligned}
 Z^{(\widetilde{G_{\mathcal{P}}^{\alpha}} \circ I_{\mathcal{P}}^{\alpha})^{(Y)}}(\mathbf{m}'(\mathbf{t}, \eta_{\alpha}), \boldsymbol{\eta}'(\{\mathbf{v}^{\beta}\}, \{\mathbf{m}^{\gamma}\}_{\gamma \neq \beta}, \boldsymbol{\mu})) &= \int \prod_{\gamma'=1}^{L^{\vee}} [d\boldsymbol{\sigma}^{\gamma'}] \delta\left(\eta_{\alpha} + \sum_{\beta} b_{\beta}^l t_l + \sum_{\beta} (-\text{Tr} \boldsymbol{\sigma}^{\alpha'_{\beta} - 1} + \text{Tr} \boldsymbol{\sigma}^{\alpha'_{\beta}})\right) \\
 &\times Z_{\text{int}}^{(Y, \{\mathcal{P}_{\beta}\})}(\{\boldsymbol{\sigma}^{\gamma'}\}, -\mathbf{t}, \{\mathbf{u}^{\beta} = \mu^{\beta}\}, \{\mathbf{v}^{\beta}\}, \{\mathbf{m}^{\gamma}\}_{\gamma \neq \beta}).
 \end{aligned} \tag{4.27}$$

The form of the expressions on the r.h.s. of (4.25) and (4.27) imply that the dual of the Abelian S -type operation $\mathcal{O}_{\mathcal{P}}^{\alpha} = (G_{\mathcal{P}}^{\alpha} \circ I_{\mathcal{P}}^{\alpha})$ is an ungauging operation which removes a single $U(1)$ factor from the gauge group. The precise $U(1)$ factor to be removed is specified by the function $\sum_{\beta} g_{\beta}$ in the delta function. Similar to the simple gauging case, the ungauging operation corresponding to the dual of $(G_{\mathcal{P}}^{\alpha} \circ I_{\mathcal{P}}^{\alpha})$ also results in a manifestly Lagrangian theory.

4.1.4 Identification-flavoring-gauging

Consider an Abelian elementary S -type operation $\mathcal{O}_{\mathcal{P}}^{\alpha}$ which involves identifying $U(1)$ flavor symmetries from p distinct nodes in a generic quiver X , followed by flavoring the identified node with N_F^{α} hypers of charge 1, and finally by gauging the identified $U(1)$ flavor node. Following the notation of section 3.2, we denote this operation as $\mathcal{O}_{\mathcal{P}}^{\alpha} = G_{\mathcal{P}}^{\alpha} \circ F_{\mathcal{P}}^{\alpha} \circ I_{\mathcal{P}}^{\alpha}$.

The flavor symmetry introduced by the operation $\mathcal{O}_{\mathcal{P}}$ is $G_F^{\alpha} = U(p) \times U(N_F^{\alpha})$, modulo an overall $U(1)$ factor. The $U(p)$ -valued masses are labelled as $\boldsymbol{\mu} = (\mu^{\gamma_1}, \dots, \mu^{\gamma_p})$, and the $U(N_F^{\alpha})$ -valued masses are labelled as $\{m_k^{\alpha_F}\}$, where $k = 1, \dots, N_F^{\alpha}$. The function $\mathcal{Z}_{G_{\mathcal{P}}^{\alpha} \circ F_{\mathcal{P}}^{\alpha} \circ I_{\mathcal{P}}^{\alpha}}(X)$, which can be read off from (3.4), (3.6), (3.11), and (3.17), is given as

$$\mathcal{Z}_{G_{\mathcal{P}}^{\alpha} \circ F_{\mathcal{P}}^{\alpha} \circ I_{\mathcal{P}}^{\alpha}}(X)(u^{\alpha}, \{\mathbf{u}^{\beta}\}, \eta_{\alpha}, \mathbf{m}_F^{\alpha}, \boldsymbol{\mu}) = Z_{\text{FI}}(u^{\alpha}, \eta_{\alpha}) Z_{1\text{-loop}}^{\text{hyper}}(u^{\alpha}, \mathbf{m}_F^{\alpha}) \int \prod_{j=1}^p du^{\gamma_j} \prod_{j=1}^p \delta(u^{\alpha} - u^{\gamma_j} + \mu^{\gamma_j}). \tag{4.28}$$

Using the general formula (3.60), and the identity (4.9) for $Z_{1\text{-loop}}^{\text{hyper}}$, the function $\mathcal{Z}_{(G_{\mathcal{P}}^{\alpha} \circ \widetilde{F_{\mathcal{P}}^{\alpha}} \circ I_{\mathcal{P}}^{\alpha})(Y)}$ is given as

$$\begin{aligned} \mathcal{Z}_{(G_{\mathcal{P}}^{\alpha} \circ \widetilde{F_{\mathcal{P}}^{\alpha}} \circ I_{\mathcal{P}}^{\alpha})(Y)} &= \int du^{\alpha} \mathcal{Z}_{G_{\mathcal{P}}^{\alpha} \circ F_{\mathcal{P}}^{\alpha} \circ I_{\mathcal{P}}^{\alpha}(X)}(\{u^{\beta}\}, \eta_{\alpha}, \mathbf{m}_F^{\alpha}, \boldsymbol{\mu}) \prod_{\beta} e^{2\pi i (g_{\beta}(\{\sigma^{\gamma'}\}, \mathcal{P}) + b_{\beta}^l \eta_l) u^{\beta}} \\ &= \int \prod_{k=1}^{N_F^{\alpha}} d\tau_k^{\alpha} Z_{\text{int}}^{(\mathcal{T}[N_F^{\alpha}])}(\boldsymbol{\tau}^{\alpha}, \{u^{\alpha} = 0, \mathbf{m}_F^{\alpha}\}, 0) \prod_{\beta} e^{2\pi i (g_{\beta}(\{\sigma^{\gamma'}\}, \mathcal{P}_{\beta}) + b_{\beta}^l \eta_l) \mu^{\beta}} \\ &\quad \times \delta\left(\tau_1^{\alpha} + \eta_{\alpha} + \sum_{\beta} b_{\beta}^l \eta_l + \sum_{\beta} g_{\beta}(\{\sigma^{\gamma'}\}, \mathcal{P}_{\beta})\right), \end{aligned} \tag{4.29}$$

where, in obtaining the second equality, we have used the delta functions in (4.28) and integrated over u^{α} . Proceeding in the same way as in the flavoring-gauging case and relabelling the integration variables $\tau_k^{\alpha} \rightarrow \tau_{k-1}^{\alpha}$, one can recast $\mathcal{Z}_{(G_{\mathcal{P}}^{\alpha} \circ \widetilde{F_{\mathcal{P}}^{\alpha}} \circ I_{\mathcal{P}}^{\alpha})(Y)}$ in the following form (up to a $\sigma^{\gamma'}$ -independent phase factor):

$$\begin{aligned} \mathcal{Z}_{(G_{\mathcal{P}}^{\alpha} \circ \widetilde{F_{\mathcal{P}}^{\alpha}} \circ I_{\mathcal{P}}^{\alpha})(Y)} &= \int \prod_{k=1}^{N_F^{\alpha}-1} d\tau_k^{\alpha} e^{2\pi i \sum_{\beta} g_{\beta}(\{\sigma^{\gamma'}\}, \mathcal{P}_{\beta}) (\mu^{\beta} + m_{1F}^{\alpha})} Z_{\text{int}}^{(\mathcal{T}[N_F^{\alpha}-1])}(\boldsymbol{\tau}^{\alpha}, \mathbf{m}_F^{\alpha}, 0) \\ &\quad \times Z_{(G_{\mathcal{P}}^{\alpha} \circ \widetilde{F_{\mathcal{P}}^{\alpha}} \circ I_{\mathcal{P}}^{\alpha})(Y)}^{\text{hyper}}(\{\sigma^{\gamma'}\}, \tau_1^{\alpha}, \eta_{\alpha}, \boldsymbol{\eta}), \end{aligned} \tag{4.30}$$

$$Z_{(G_{\mathcal{P}}^{\alpha} \circ \widetilde{F_{\mathcal{P}}^{\alpha}} \circ I_{\mathcal{P}}^{\alpha})(Y)}^{\text{hyper}}(\{\sigma^{\gamma'}\}, \tau_1^{\alpha}, \eta_{\alpha}, \boldsymbol{\eta}) = \frac{1}{\cosh \pi (\sum_{\beta} g_{\beta}(\{\sigma^{\gamma'}\}, \mathcal{P}_{\beta}) + \tau_1^{\alpha} + \eta_{\alpha} + \sum_{\beta} b_{\beta}^l \eta_l)}. \tag{4.31}$$

The function $Z_{(G_{\mathcal{P}}^{\alpha} \circ \widetilde{F_{\mathcal{P}}^{\alpha}} \circ I_{\mathcal{P}}^{\alpha})(Y)}$ can be identified as the 1-loop contribution of a single hypermultiplet charged under certain U(1) subgroups of the gauge group of Y and the group U(1)₁ of $\mathcal{T}[N_F^{\alpha} - 1]$. Following the general prescription (3.59), the partition function of the theory $(G_{\mathcal{P}}^{\alpha} \circ F_{\mathcal{P}}^{\alpha} \circ I_{\mathcal{P}}^{\alpha})(Y)$ is given as

$$\begin{aligned} Z_{(G_{\mathcal{P}}^{\alpha} \circ \widetilde{F_{\mathcal{P}}^{\alpha}} \circ I_{\mathcal{P}}^{\alpha})(Y)}(\mathbf{m}'(\boldsymbol{\eta}, \eta_{\alpha}), \boldsymbol{\eta}'(\{\mathbf{v}^{\beta}\}, \dots, \boldsymbol{\mu}, \mathbf{m}_F^{\alpha})) &= \int \prod_{\gamma'} [d\sigma^{\gamma'}] \int \prod_{k=1}^{N_F^{\alpha}-1} d\tau_k^{\alpha} Z_{\text{int}}^{(\mathcal{T}[N_F^{\alpha}-1])}(\boldsymbol{\tau}^{\alpha}, \mathbf{m}_F^{\alpha}, 0) \\ &\quad \times Z_{(G_{\mathcal{P}}^{\alpha} \circ \widetilde{F_{\mathcal{P}}^{\alpha}} \circ I_{\mathcal{P}}^{\alpha})(Y)}^{\text{hyper}}(\{\sigma^{\gamma'}\}, \tau_1^{\alpha}, \eta_{\alpha}, \boldsymbol{\eta}) \cdot Z_{\text{int}}^{(Y, \{\mathcal{P}_{\beta}\})}(\{\sigma^{\gamma'}\}, \mathbf{m}^Y(\boldsymbol{\eta}), \boldsymbol{\eta}^Y(\{\mathbf{u}^{\beta} = \mu^{\beta} + m_{1F}^{\alpha}\}, \{\mathbf{v}^{\beta}\}, \dots)). \end{aligned} \tag{4.32}$$

The dual theory $(G_{\mathcal{P}}^{\alpha} \circ \widetilde{F_{\mathcal{P}}^{\alpha}} \circ I_{\mathcal{P}}^{\alpha})(Y)$ is therefore manifestly Lagrangian, and can be represented by a generic quiver diagram of the following form:

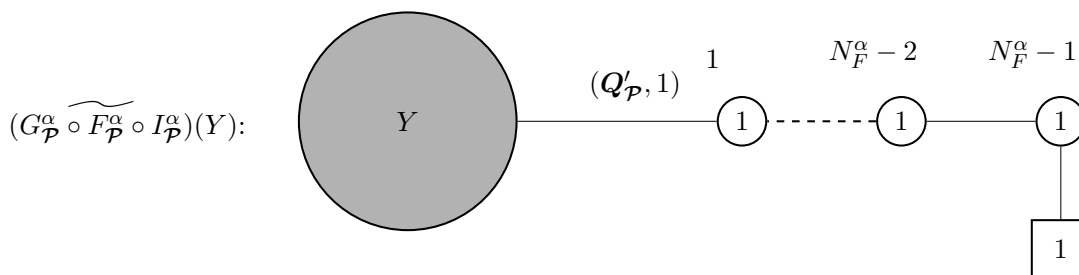

The theory consists of a $\mathcal{T}[N_F^{\alpha} - 1]$ tail attached to the quiver Y by a single hypermultiplet, which is also charged under some of the U(1) factors in the gauge group of Y . $(\mathbf{Q}'_{\mathcal{P}}, 1)$

collectively denotes the charges of the hypermultiplet connecting Y and $\mathcal{T}[N_F^\alpha - 1]$, under various $U(1)$ factors of Y and $U(1)_1$ of $\mathcal{T}[N_F^\alpha - 1]$ respectively. Note that

1. The charge vector $\mathbf{Q}'_{\mathcal{P}}$, and therefore the precise shape of the quiver, depends on the choice of the permutation matrices $\{\mathcal{P}_\beta\}$.
2. In the special case, where $N_F^\alpha = 1$, the function $\mathcal{Z}_{(\widetilde{G \circ F \circ I})_{\{\mathcal{P}_\beta\}}(Y)}$ is given as

$$\mathcal{Z}_{(\widetilde{G \circ F \circ I})_{\{\mathcal{P}_\beta\}}(Y)} = e^{2\pi i \sum_\beta g_\beta(\{\sigma^{\gamma'}\}, \mathcal{P}_\beta)} (\mu^\beta + m_F^\alpha) Z_{(\widetilde{G \circ F \circ I})_{\{\mathcal{P}_\beta\}}(Y)}^{\text{hyper}} \times \left(\{\sigma^{\gamma'}\}, \eta_\alpha, \boldsymbol{\eta} \right), \quad (4.33)$$

$$Z_{(\widetilde{G \circ F \circ I})_{\{\mathcal{P}_\beta\}}(Y)}^{\text{hyper}} \left(\{\sigma^{\gamma'}\}, \eta_\alpha, \boldsymbol{\eta} \right) = \frac{1}{\cosh \pi (\sum_\beta g_\beta(\{\sigma^{\gamma'}\}, \mathcal{P}_\beta) + \eta_\alpha + \sum_\beta b_\beta^l \eta_l)}. \quad (4.34)$$

The dual partition function is then given as

$$Z_{(\widetilde{G \circ F \circ I})_{\{\mathcal{P}_\beta\}}(Y)}(\mathbf{m}'(\boldsymbol{\eta}, \eta_\alpha); \boldsymbol{\eta}'(\mathbf{v}^\alpha, \dots, m_F^\alpha)) = \int \prod_{\gamma'} [d\sigma^{\gamma'}] Z_{(\widetilde{G \circ F \circ I})_{\{\mathcal{P}_\beta\}}(Y)}^{\text{hyper}} \left(\{\sigma^{\gamma'}\}, \eta_\alpha, \boldsymbol{\eta} \right) \times Z_{\text{int}}^{(Y, \mathcal{P})}(\{\sigma^{\gamma'}\}, \mathbf{m}^Y(\boldsymbol{\eta}), \boldsymbol{\eta}^Y(\{\mathbf{u}^\beta = \mu^\beta + m_F^\alpha, \{\mathbf{v}^\beta\}, \dots)). \quad (4.35)$$

The dual theory $(\widetilde{G \circ F \circ I})_{\{\mathcal{P}_\beta\}}(Y)$ in this case is simpler. It merely involves introducing an extra hypermultiplet in the quiver gauge theory Y , such that the hypermultiplet is charged under a certain $U(1)^r$ subgroup (r is an integer) of the gauge group. The FI parameters $\{u^\beta\}$ in $Z_{\text{int}}^{(Y, \mathcal{P})}$ is also replaced by the mass parameters $\{\mu^\beta + m_F^\alpha\}$.

Linear quivers. For a linear quiver pair (X, Y) , the above partition function can be written as

$$Z_{(\widetilde{G \circ F \circ I})_{\{\mathcal{P}_\beta\}}(Y)}(\mathbf{m}'(\mathbf{t}, \eta_\alpha), \boldsymbol{\eta}'(\{\mathbf{v}^\beta\}, \boldsymbol{\mu}, \mathbf{m}_F^\alpha, \{\mathbf{m}^\gamma\}_{\gamma \neq \beta})) = \int \prod_{\gamma'=1}^{L^\vee} [d\sigma^{\gamma'}] \int \prod_{k=1}^{N_F^\alpha - 1} d\tau_k Z_{\text{int}}^{(\mathcal{T}[N_F^\alpha - 1])}(\boldsymbol{\tau}^\alpha, \mathbf{m}_F^\alpha, 0) \times Z_{(\widetilde{G \circ F \circ I})_{\{\mathcal{P}_\beta\}}(Y)}^{\text{hyper}} \left(\{\sigma^{\gamma'}\}, \tau_1^\alpha, \eta_\alpha, \mathbf{t} \right) \cdot Z_{\text{int}}^{(Y, \{\mathcal{P}_\beta\})}(\{\sigma^{\gamma'}\}, -\mathbf{t}, \{\mathbf{u}^\beta = \mu^\beta + m_{1F}^\alpha, \{\mathbf{v}^\beta\}, \{\mathbf{m}^\gamma\}_{\gamma \neq \beta}). \quad (4.36)$$

In this case, the hypermultiplet contribution can be written explicitly, and the $U(1)$ charges $\mathbf{Q}'_{\mathcal{P}}$ can be read off:

$$Z_{(\widetilde{G \circ F \circ I})_{\{\mathcal{P}_\beta\}}(Y)}^{\text{hyper}} \left(\{\sigma^{\gamma'}\}, \tau_1^\alpha, \eta_\alpha, \mathbf{t} \right) = \frac{1}{\cosh \pi (\sum_\beta g_\beta(\{\sigma^{\gamma'}\}, \mathcal{P}_\beta) + \tau_1^\alpha + \eta_\alpha + \sum_\beta b_\beta^l \eta_l)} \quad (4.37) \\ = \frac{1}{\cosh \pi (\sum_\beta (-\text{Tr} \boldsymbol{\sigma}^{\alpha' \beta - 1} + \text{Tr} \boldsymbol{\sigma}^{\alpha' \beta}) + \tau_1^\alpha + \eta_\alpha + \sum_\beta b_\beta^l t_l)},$$

where the functions $\{g_\beta\}$ and the gauge node labels $\{\alpha'_\beta\}$ are defined in (4.26). For the special case $N_F^\alpha = 1$, the dual partition function again assumes a simplified form:

$$Z^{(G_{\mathcal{P}}^\alpha \circ \widetilde{F_{\mathcal{P}}^\alpha} \circ I_{\mathcal{P}}^\alpha)(Y)}(\mathbf{m}'(\mathbf{t}, \eta_\alpha), \boldsymbol{\eta}'(\{\mathbf{v}^\beta\}, \boldsymbol{\mu}, \mathbf{m}_F^\alpha, \{\mathbf{m}^\gamma\}_{\gamma \neq \beta})) \tag{4.38}$$

$$= \int \prod_{\gamma'=1}^{L^\vee} [d\boldsymbol{\sigma}^{\gamma'}] Z_{(G_{\mathcal{P}}^\alpha \circ \widetilde{F_{\mathcal{P}}^\alpha} \circ I_{\mathcal{P}}^\alpha)(Y)}^{\text{hyper}}(\{\boldsymbol{\sigma}^{\gamma'}\}, \eta_\alpha, \mathbf{t}) \cdot Z_{\text{int}}^{(Y, \{\mathcal{P}_\beta\})}(\{\boldsymbol{\sigma}^{\gamma'}\}, -\mathbf{t}, \{\mathbf{u}^\beta = \boldsymbol{\mu}^\beta + \mathbf{m}_F^\alpha\}, \{\mathbf{v}^\beta\}, \{\mathbf{m}^\gamma\}_{\gamma \neq \beta}),$$

$$Z_{(G_{\mathcal{P}}^\alpha \circ \widetilde{F_{\mathcal{P}}^\alpha} \circ I_{\mathcal{P}}^\alpha)(Y)}^{\text{hyper}}(\{\boldsymbol{\sigma}^{\gamma'}\}, \eta_\alpha, \mathbf{t}) = \frac{1}{\cosh \pi (\sum_\beta (-\text{Tr} \boldsymbol{\sigma}^{\alpha'_\beta - 1} + \text{Tr} \boldsymbol{\sigma}^{\alpha'_\beta}) + \eta_\alpha + \sum_\beta b'_\beta t_l)}. \tag{4.39}$$

The special cases of flavoring-gauging operations with $N^\alpha = 1$, given by (4.34)–(4.35) and (4.38)–(4.39) for a generic quiver and a linear quiver respectively, will be used frequently for the construction of non-ADE mirror duals later in this section.

4.1.5 A qualitative description of the dual operations

While we have determined the precise dual operations at the level of the quiver gauge theories above, their qualitative forms could be guessed from the fact that mirror symmetry exchanges Higgs branch global symmetry on one side of the duality with the Coulomb branch global symmetry on the other. The dual of the Abelian gauging operation on X will therefore involve gauging of a $U(1)_J$ topological symmetry of Y , which is equivalent to ungauging a $U(1)$ subgroup of the gauge group of Y . The precise $U(1)$ being ungauged can be read off from the matrix model and is realized by the function $g_\alpha(\{\boldsymbol{\sigma}^{\gamma'}\}, \mathcal{P})$ in (4.5) set to a constant. The same qualitative reasoning also applies to the case of Abelian identification-gauging, with the ungauging of the $U(1)$ subgroup being realized by setting the function $\sum_\beta g_\beta(\{\boldsymbol{\sigma}^{\gamma'}\}, \mathcal{P}_\beta)$ in (4.25) to a constant.

A flavoring-gauging operation can be viewed as identifying the $U(1)$ flavor symmetry of the theory X with a $U(1)$ flavor symmetry subgroup of N_F^α free hypermultiplets, and then gauging it. If the $U(1)$ flavor symmetry in X were gauged without this identification, then the dual operation would involve ungauging a certain $U(1)$ subgroup of the gauge group of Y , as argued above. Let us call this $U(1)$ subgroup $U(1)_Y$. Similarly, if the $U(1)$ flavor symmetry of the free hypers were gauged separately, one would ungauged the $U(1)_1$ node of the quiver $\mathcal{T}[N_F^\alpha]$ (see the discussion after (4.9)) on the dual side. This would give a linear chain of $N_F^\alpha - 1$ $U(1)$ nodes with a fundamental hyper at each end, which is indeed the correct mirror of a $U(1)$ theory with N_F^α flavors.

In contrast, the identification of the two $U(1)$ flavor symmetries, roughly speaking, leads to an identification of FI parameters associated with the $U(1)_1$ and $U(1)_Y$ on the dual side. The gauging operation then, following the logic presented above, leads to the dual operation where a linear combination of $U(1)_1$ and $U(1)_Y$ is ungauged. While the precise form of the linear combination can be read off from the matrix model integral, this generically produces a quiver $Y' = (G_{\mathcal{P}}^\alpha \circ \widetilde{F_{\mathcal{P}}^\alpha})(Y)$ of the form shown in the paragraph following (4.13). The same qualitative reasoning also applies to the case of Abelian identification-flavoring-gauging.

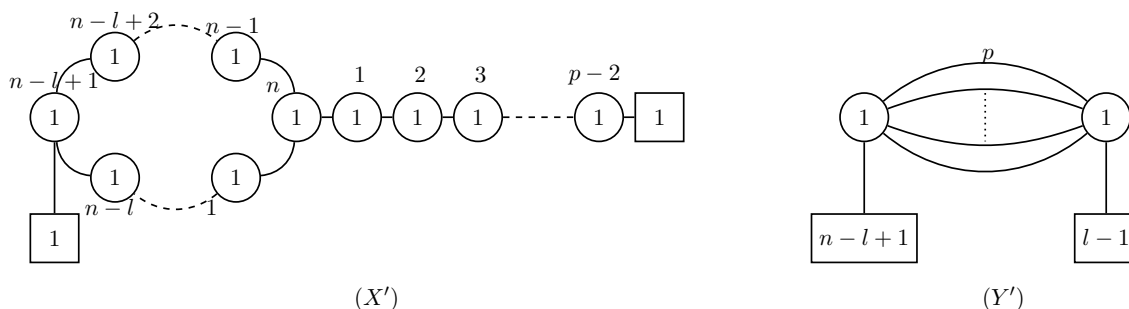

Figure 17. A three-parameter family of dual quiver gauge theory pairs with $U(1)$ gauge groups labelled by the integers (n, l, p) with $n > l - 1 > 0$, and $p \geq 2$. Their construction from linear quivers by identification-gauging operations is shown in figure 19.

Moduli space data	Theory X'	Theory Y'
$\dim \mathcal{M}_H$	2	$n+p-2$
$\dim \mathcal{M}_C$	$n+p-2$	2
G_H	$U(1) \times U(1)$	$SU(p) \times SU(n-l+1) \times SU(l-1) \times U(1)$
G_C	$SU(p) \times SU(n-l+1) \times SU(l-1) \times U(1)$	$U(1) \times U(1)$

Table 5. Summary table for the moduli space dimensions and global symmetries for the mirror pair in figure 17.

4.2 Examples of Abelian quiver pairs

4.2.1 Family $I_{[n,l,p]}$: a single closed loop attached to a linear quiver tail

The first example in the class of Abelian mirrors is the infinite family of mirror duals shown in figure 17, labelled by three positive integers (n, l, p) with the constraints $n - l + 1 > 0$, $l > 1$, and $p \geq 2$. The theory X' has the shape of a single closed loop attached to a linear quiver tail, while the theory Y' is a quiver with two nodes connected by multiple edges. The dimensions of the respective Higgs and Coulomb branches, and the associated global symmetries are shown in table 5.

The quiver pair (X', Y') in figure 17 can be generated from the linear quiver pair (X, Y) in figure 18 by a series of elementary Abelian operations on X and the dual operations on Y , as shown in figure 19. The Higgs branch global symmetry of X is given by $G_H^X = U(1)^3/U(1) = U(1) \times U(1)$. Using the notation introduced in section 2.4, the mass parameters are labelled as $\mathbf{m} = (m_1, m_2, m_3)$, and the quotient by the overall $U(1)$ factor in the flavor symmetry of quiver X can be implemented by the constraint $m_2 = 0$. The $U(1) \times U(1)$ flavor symmetry of X can then be identified with the two terminal $U(1)$ flavor nodes, parametrized by the independent (m_1, m_3) .

To obtain X' from X , we first perform an identification-flavoring-gauging operation¹³ \mathcal{O}_1 on the flavor nodes (marked in red) at the two ends of the quiver X , with $N_F^\alpha = 1$.

¹³As mentioned earlier in section 3.4, we drop the superscript α from the notation \mathcal{O}_P^α when there is no ambiguities regarding the flavor nodes on which the S -type operation acts. In cases where \mathcal{P} is trivial, we drop the subscript as well.

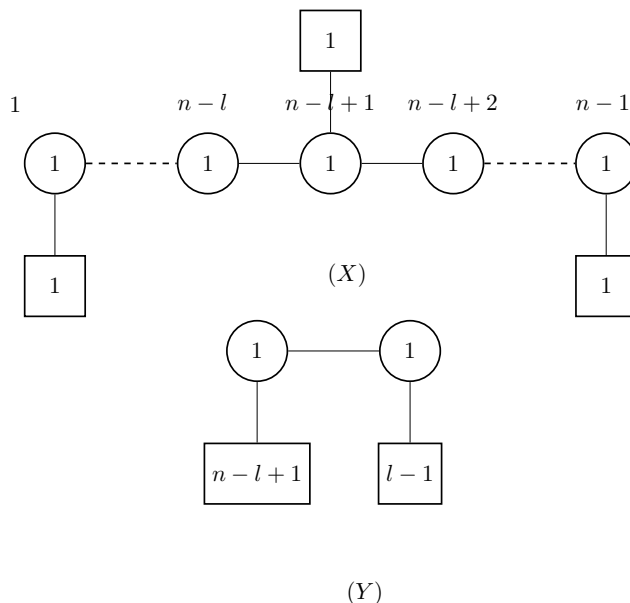

Figure 18. Pair of linear quivers with U(1) gauge groups which generate the 3d mirrors in figure 17.

This step is precisely the same as the illustrative example studied in section 3.4. This is followed by a flavoring-gauging operation \mathcal{O}_2 on the quiver $\mathcal{O}_1(X)$ at the new flavor node (also marked in red), again with $N_F^\alpha = 1$. The quiver X' can be obtained by implementing a sequence of $p - 2$ such flavoring-gauging operations, each acting at the new flavor node obtained in the previous step. Let us adopt the notation:

$$X^{(i)} = \mathcal{O}_i \circ \mathcal{O}_{i-1} \circ \dots \circ \mathcal{O}_2 \circ \mathcal{O}_1(X), \tag{4.40}$$

$$Y^{(i)} = \tilde{\mathcal{O}}_i \circ \tilde{\mathcal{O}}_{i-1} \circ \dots \circ \tilde{\mathcal{O}}_2 \circ \tilde{\mathcal{O}}_1(Y), \tag{4.41}$$

where \mathcal{O}_1 is an identification-flavoring-gauging operation, and \mathcal{O}_i ($i > 1$) are flavoring-gauging operations. We will denote the $\mathcal{N} = 4$ -preserving deformations of the quivers $X^{(i)}$ and $Y^{(i)}$ as $(\mathbf{m}^{(i)}, \boldsymbol{\eta}^{(i)})$ and $(\mathbf{m}'^{(i)}, \boldsymbol{\eta}'^{(i)})$ respectively. In this notation, we have

$$X' = X^{(p-1)}, Y' = Y^{(p-1)}. \tag{4.42}$$

We will denote the deformation parameters of the dual theories X' and Y' as $(\mathbf{m}, \boldsymbol{\eta})$ and $(\mathbf{m}', \boldsymbol{\eta}')$ respectively, which obviously implies

$$(\mathbf{m}, \boldsymbol{\eta}) = (\mathbf{m}^{(p-1)}, \boldsymbol{\eta}^{(p-1)}), \quad (\mathbf{m}', \boldsymbol{\eta}') = (\mathbf{m}'^{(p-1)}, \boldsymbol{\eta}'^{(p-1)}). \tag{4.43}$$

The masses associated with the identification operation are parametrized as $\boldsymbol{\mu}$, while the mass associated with flavoring operation at the i -th step is $m_F^\alpha = m_F^{(i)}$. The FI parameter associated to the gauging operation at the i -th step is $\eta_\alpha = \tilde{\eta}^{(i)}$.

Let us begin with the dual operation for $\mathcal{O}_1(X)$. This was already worked out in section 3.4. We will now derive that result using the general Abelian formula (4.38)–(4.39) in section 4.1.4. Following the notation in section 4.1 (originally introduced in section 3.2),

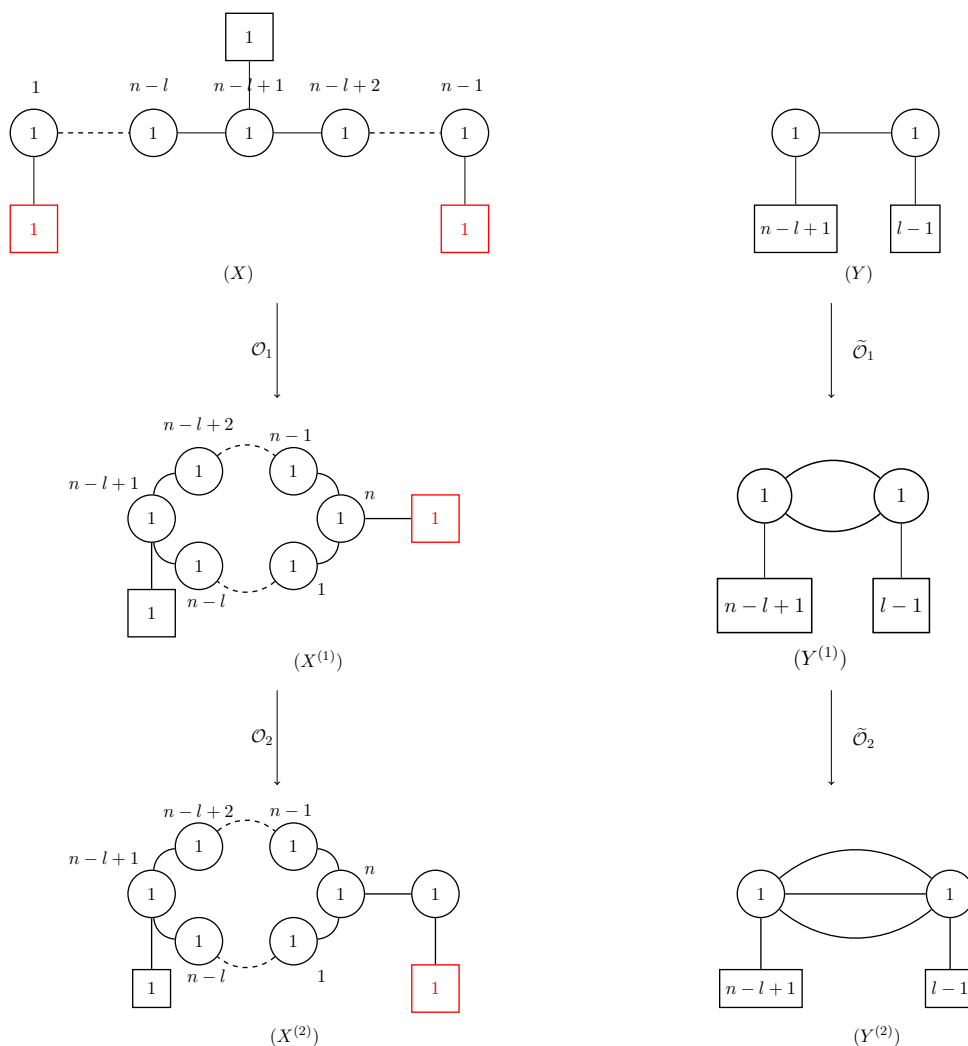

Figure 19. The quiver (X') and its mirror dual (Y') in figure 17 (for $p = 3$) is generated by a sequence of elementary S -type operations on different nodes. In each step, the flavor node(s) on which the S -type operation acts is shown in red.

let us define the variables $\{\mathbf{u}^\beta\}$, which parametrize the $U(1) \times U(1)$ mass parameters of the quiver X :

$$u^1 = m_1, u^2 = m_3, \tag{4.44}$$

and implement the S -type operation \mathcal{O}_1 on the relevant flavor nodes of X . Note that the permutation matrices $\{\mathcal{P}_\beta\}$ are trivial in this case. The resultant quiver $\mathcal{O}_1(X) = X^{(1)}$ is shown in the second line of figure 19.

The dual quiver $\tilde{\mathcal{O}}_1(Y)$ can then be constructed using the general recipe presented in section 4.1.4 — the expressions (4.38)–(4.39) give the dual partition function. The expression (4.38) implies that the dual quiver $\tilde{\mathcal{O}}_1(Y)$ simply involves adding an extra hy-

permutiplet to the quiver gauge theory Y , i.e.

$$\begin{aligned}
 Z^{\tilde{\mathcal{O}}_1(Y)}(\mathbf{m}'^{(1)}, \boldsymbol{\eta}'^{(1)}) &= \int \prod_{\gamma'=1}^2 [d\sigma^{\gamma'}] Z_{\tilde{\mathcal{O}}_1(Y)}^{\text{hyper}}(\sigma^1, \sigma^2, \tilde{\eta}^{(1)}, \mathbf{t}) Z_{\text{int}}^{(Y)}(\sigma^1, \sigma^2, -\mathbf{t}, \{\mathbf{u}^\beta = \mu^\beta + m_F^{(1)}\}) \quad (4.45) \\
 &= \int \prod_{\gamma'=1}^2 [d\sigma^{\gamma'}] Z_{\tilde{\mathcal{O}}_1(Y)}^{\text{hyper}}(\sigma^1, \sigma^2, \tilde{\eta}^{(1)}, \mathbf{t}) Z_{\text{int}}^{(Y)}(\sigma^1, \sigma^2, -\mathbf{t}, \{m_1 = \mu^1 + m_F^{(1)}, m_2 = 0, m_3 = \mu^2 + m_F^{(1)}\}),
 \end{aligned}$$

where $\mathbf{m}'^{(1)} = \mathbf{m}^{(1)}(\mathbf{t}, \tilde{\eta}^{(1)})$, $\boldsymbol{\eta}'^{(1)} = \boldsymbol{\eta}^{(1)}(m_F^{(1)}, \boldsymbol{\mu})$ are linear functions of their arguments. The problem then is reduced to writing down the contribution of the hypermultiplet $Z_{\tilde{\mathcal{O}}_1(Y)}^{\text{hyper}}$. From (4.39), this is given as

$$Z_{\tilde{\mathcal{O}}_1(Y)}^{\text{hyper}}(\sigma^1, \sigma^2, \tilde{\eta}^{(1)}, \mathbf{t}) = \frac{1}{\cosh \pi(\sigma^1 - \sigma^2 + \tilde{\eta}^{(1)} + \sum_\beta b_\beta^l t_l)} =: Z_{1\text{-loop}}^{\text{bif}}\left(\sigma^1, \sigma^2, -\tilde{\eta}^{(1)} - \sum_\beta b_\beta^l t_l\right). \quad (4.46)$$

The new hypermultiplet can therefore be identified as a bifundamental hypermultiplet with a mass $m_{\text{bif}} = -\tilde{\eta}^{(1)} - \sum_\beta b_\beta^l t_l$, and this leads to the quiver $Y^{(1)}$ in the second line of figure 19.¹⁴ Finally, the mirror map between the masses and the FI parameters can be read off from (4.45)–(4.46), and can be recast in the form (3.74)–(3.75) after appropriately redefining the integration variables and mass parameters ($m_F^{(1)} \rightarrow m_F^{(1)} - \mu^1$ with $\mu = \mu^2 - \mu^1$).

Now consider implementing the flavoring-gauging operation \mathcal{O}_2 on the quiver $X^{(1)} = \mathcal{O}_1(X)$. Following the notation of section 4, we label the new flavor node, arising from the operation \mathcal{O}_1 in the previous step, as α . We define the associated mass parameter as

$$u^\alpha = m_F^{(1)}. \quad (4.47)$$

Note that the permutation matrix \mathcal{P} is trivial in this case. The quiver $\mathcal{O}_2(X^{(1)}) = X^{(2)}$ is shown in figure 19.

The dual quiver $\tilde{\mathcal{O}}_2(Y^{(1)})$ can then be constructed using the general recipe presented in section 4.1.2. The expressions (4.14)–(4.15) show that the dual quiver $\tilde{\mathcal{O}}_2(Y^{(1)})$ is given by adding one extra hypermultiplet to the quiver gauge theory $Y^{(1)}$, i.e.

$$\begin{aligned}
 Z^{\tilde{\mathcal{O}}_2(Y^{(1)})}(\mathbf{m}'^{(2)}, \boldsymbol{\eta}'^{(2)}) &= \int \prod_{\gamma'=1}^2 [d\sigma^{\gamma'}] Z_{\text{int}}^{(Y^{(1)})}(\sigma^1, \sigma^2, \mathbf{m}'^{(1)}(\mathbf{t}, \tilde{\eta}^{(1)}), \boldsymbol{\eta}'^{(1)}(u^\alpha = m_F^{(2)}, \boldsymbol{\mu})) \\
 &\quad \times Z_{\tilde{\mathcal{O}}_2(Y^{(1)})}^{\text{hyper}}(\sigma^1, \sigma^2, \tilde{\eta}^{(2)}, \boldsymbol{\eta}^{(1)}(\mathbf{t}, \tilde{\eta}^{(1)})), \quad (4.48)
 \end{aligned}$$

where the explicit form of the function $Z_{\text{int}}^{(Y^{(1)})}$ can be read off from (4.45), and the function $Z_{\tilde{\mathcal{O}}_2(Y^{(1)})}^{\text{hyper}}$ is given by (4.14). The function $g_\alpha(\sigma_1, \sigma_2)$ in (4.14) can be read off from the FI term appearing in the r.h.s. of (4.45), which gives $g_\alpha(\sigma_1, \sigma_2) = \sigma_1 - \sigma_2$. Therefore, the

¹⁴The matrix b_β^l can be read off from the precise mirror symmetry relation between $Z^{(X)}$ and $Z^{(Y)}$, i.e.

$$Z^{(X)}(\mathbf{u}; \mathbf{t}) = e^{2\pi i(t_1 u^1 - t_n u^2)} Z^{(Y)}(-\mathbf{t}; \mathbf{u}), \implies b_\beta^l t_l u^\beta = (t_1 u^1 - t_n u^2), \quad (l = 1, \dots, n, \beta = 1, 2).$$

hypermultiplet term reads:

$$Z_{\tilde{\mathcal{O}}_2(Y^{(1)})}^{\text{hyper}}(\sigma^1, \sigma^2, \tilde{\eta}^{(2)}, \boldsymbol{\eta}^{(1)}(\mathbf{t}, \tilde{\eta}^{(1)})) = Z_{1\text{-loop}}^{\text{bif}} \left(\sigma^1, \sigma^2, -\tilde{\eta}^{(1)} - \tilde{\eta}^{(2)} - \sum_{\beta} b_{\beta}^l t_l \right), \quad (4.49)$$

The new hypermultiplet can therefore be identified as a bifundamental hyper with a mass parameter $m_{\text{bif}} = -\tilde{\eta}^{(1)} - \tilde{\eta}^{(2)} - \sum_{\beta} b_{\beta}^l t_l$. The resultant quiver then is given by $Y^{(2)}$ in the third line of figure 19. The mirror map for the dual theories $X^{(2)}, Y^{(2)}$ can be read off from (4.48)–(4.49).

In the next step, we implement the flavoring-gauging operation \mathcal{O}_3 on the quiver $X^{(2)}$ at the flavor node arising from the operation \mathcal{O}_2 on $X^{(1)}$, and so on. At the i -th step, the dual quiver $Y^{(i)}$ is given by adding a bifundamental hypermultiplet to the quiver $Y^{(i-1)}$. The dual pair (X', Y') in figure 17 is therefore generated in this fashion for $i = p - 1$. The theory Y' can be read off from the partition function:

$$Z^{Y'}(\mathbf{m}', \boldsymbol{\eta}') = \int \prod_{\gamma'=1}^2 [d\sigma^{\gamma'}] \prod_{i=1}^{p-1} Z_{1\text{-loop}}^{\text{bif}}(\sigma^1, \sigma^2, m'_{\text{bif } i}, Z_{\text{int}}^{(Y)}(\sigma^1, \sigma^2, -\mathbf{t}, \{m_F^{(p-1)}, 0, \mu + m_F^{(p-1)}\})), \quad (4.50)$$

where the parameters $m'_{\text{bif } i}$ are given as $m'_{\text{bif } i} = -\sum_{k=1}^i \tilde{\eta}^{(k)} - \sum_{\beta} b_{\beta}^l t_l$.

After a change of integration variables, the mirror map for the dual pair (X', Y') can be summarized as follows. The mass parameters of theory Y' , associated with the bifundamental and fundamental hypermultiplets, can be written as linear functions of the FI parameters of X' :

$$m'_{\text{bif } j} = \begin{cases} \delta_1 - \delta_2, & \text{if } j = 1 \\ -\sum_{k=1}^{j-1} \tilde{\eta}^{(k)} + \delta_1 - \delta_2, & \text{if } j = 2, \dots, p, \end{cases} \quad (4.51)$$

$$m_{\text{fund } i_1}^1 = -t_{i_1} + \delta_1, \quad i_1 = 1, \dots, n - l + 1, \quad (4.52)$$

$$m_{\text{fund } i_2}^2 = -t_{i_2+n-l+1} + \delta_2, \quad i_2 = 1, \dots, l - 1, \quad (4.53)$$

where $\delta_1 = \frac{\sum_{i_1} t_{i_1}}{n-l+1}$ and $\delta_2 = \frac{\sum_{i_2} t_{i_2+n-l+1}}{l-1}$. The FI parameters of the theory Y' are also given in terms of the mass parameters of X' :

$$\eta'^1 = m_F^{(p-1)}, \quad \eta'^2 = -(m_F^{(p-1)} + \mu). \quad (4.54)$$

The mass parameters of Y' manifestly live in the Cartan subalgebra of the Higgs branch global symmetry $G_H^{Y'} = \text{U}(p) \times \text{SU}(n - l + 1) \times \text{SU}(l - 1)$, while the FI parameters live in the Cartan subalgebra of the Coulomb branch global symmetry $G_C^{Y'} = \text{U}(1) \times \text{U}(1)$.

Note that the global symmetries on the Coulomb branch of theory X' looks counter-intuitive. The loop in X' has two balanced linear subquivers, consisting of $l - 2$ and $n - l$ gauge nodes respectively. This leads to the factors of $\text{SU}(l - 1)$ and $\text{SU}(n - l + 1)$ respectively in the global symmetry as expected. The linear subquiver attached to the loop has a set of $p - 2$ balanced gauge nodes which naively contribute an $\text{SU}(p - 1)$ factor to the global symmetry. However, it turns out that the naive $\text{U}(1) \times \text{U}(1) \times \text{SU}(p - 1)$ is enhanced to $\text{U}(1) \times \text{SU}(p)$ in the IR. We already saw this phenomenon for the example worked out

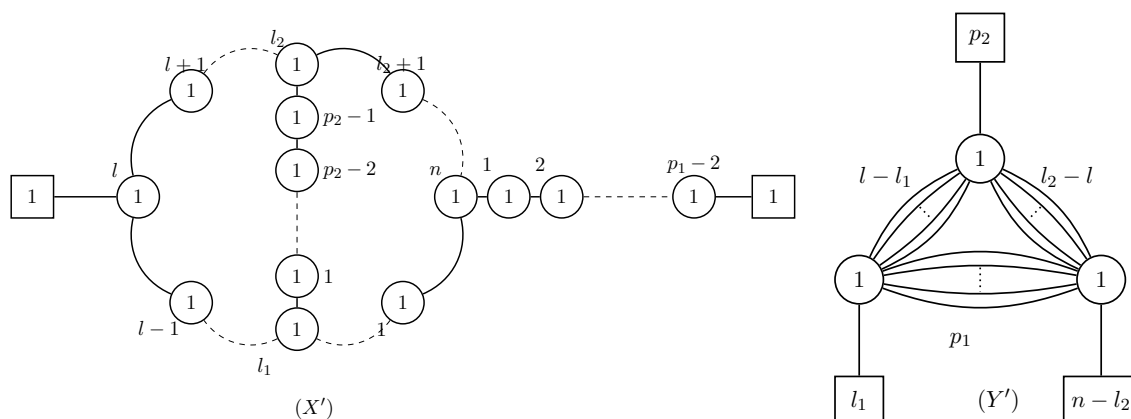

Figure 20. An infinite family of mirror duals labelled by the positive integers $(n, l, l_1, l_2, p_1, p_2)$ subject to the constraints $n > l_2 > l > l_1 > 0$, and $p_1 > 2, p_2 > 1$.

Moduli space data	Theory X'	Theory Y'
$\dim \mathcal{M}_H$	3	$n+p_1+p_2-3$
$\dim \mathcal{M}_C$	$n+p_1+p_2-3$	3
G_H	$U(1)^3$	$SU(l_1) \cdot SU(n-l_2) \cdot SU(p_2) \cdot U(l-l_1) \cdot U(l_2-l) \cdot U(p_1)$
G_C	$SU(l_1) \cdot SU(n-l_2) \cdot SU(p_2) \cdot U(l-l_1) \cdot U(l_2-l) \cdot U(p_1)$	$U(1)^3$

Table 6. Summary table for the moduli space dimensions and global symmetries for the mirror pair in figure 20.

in section 3.4 (which has an explicit Type IIB Hanany-Witten realization), corresponding to $p = 2$ with generic n and l . Similar to that example, the enhancement in the global symmetry can be explicitly checked by computing the character expansion for the Coulomb branch Hilbert Series of X' .

4.2.2 Family II_[n,l,l1,l2,p1,p2]: two closed loops attached to a linear quiver tail

The second example in the class of Abelian mirrors is the infinite family of mirror duals shown in figure 20, labelled by the positive integers $(n, l, l_1, l_2, p_1, p_2)$ subject to the constraints $n > l_2 > l > l_1 > 0$, and $p_1 > 2, p_2 > 1$. In contrast to Family I studied earlier, the quiver X' consists of two closed loops attached to a single linear quiver tail. The proposed mirror dual Y' is a quiver with three nodes in a loop connected by multiple edges. The dimensions of the respective Higgs and Coulomb branches, and the associated global symmetries are shown in table 6.

The quiver pair (X', Y') in figure 20 can be generated from the linear quiver pair (X, Y) in figure 21 by a series of elementary Abelian S -type operations on X and the dual operations on Y (shown in figure 22), which we shall describe momentarily. The Higgs branch global symmetry of X is given by $G_H^X = U(1)^5/U(1) = U(1)^4$. Using the notation introduced in section 2.4, the mass parameters are labelled as $\mathbf{m} = (m_1, m_2, m_3, m_4, m_5)$, and the quotient by the overall $U(1)$ factor in the flavor symmetry of quiver X can be implemented by the constraint $m_3 = 0$. The $U(1)^4$ flavor symmetry of X can then be

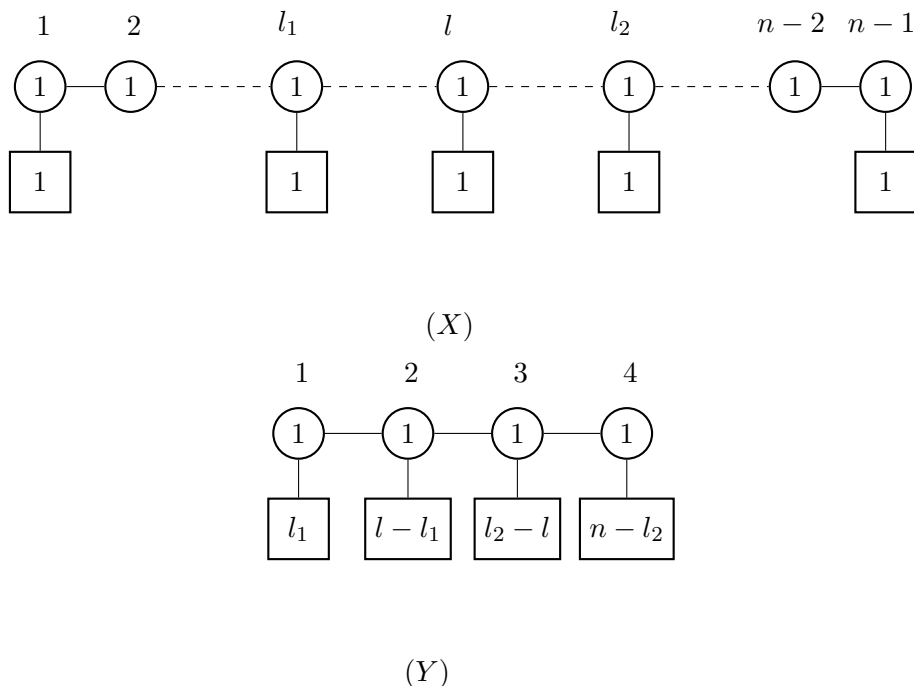

Figure 21. Pair of linear quivers with $U(1)$ gauge groups which generate the 3d mirrors in figure 20.

identified with the $U(1)_1 \times U(1)_{l_1} \times U(1)_{l_2} \times U(1)_{n-1}$ flavor nodes, parametrized by the independent (m_1, m_2, m_4, m_5) .

The theory X' can be obtained from the quiver X in three distinct set of steps, each of which involves a sequence of elementary Abelian operations:

1. The first sequence involves an identification-flavoring-gauging operation \mathcal{O}_1 on the $U(1)_1 \times U(1)_{n-1}$ flavor nodes (marked in red) at the two ends of the quiver X , followed by $p_1 - 2$ flavoring-gauging operations \mathcal{O}_i (for $i = 2, \dots, p_1 - 1$), each acting at the new flavor node generated in the previous step. At each step, the flavoring operation corresponds to $N_F^\alpha = 1$. This is very similar to the derivation of the quiver X' in Family I, studied earlier. We adopt the notation:

$$X^{(i)} = \mathcal{O}_i \circ \mathcal{O}_{i-1} \circ \dots \circ \mathcal{O}_2 \circ \mathcal{O}_1(X), \quad (4.55)$$

$$Y^{(i)} = \tilde{\mathcal{O}}_i \circ \tilde{\mathcal{O}}_{i-1} \circ \dots \circ \tilde{\mathcal{O}}_2 \circ \tilde{\mathcal{O}}_1(Y), \quad (4.56)$$

and denote the $\mathcal{N} = 4$ -preserving deformations of the quivers $X^{(i)}$ and $Y^{(i)}$ as $(\mathbf{m}^{(i)}, \boldsymbol{\eta}^{(i)})$ and $(\mathbf{m}'^{(i)}, \boldsymbol{\eta}'^{(i)})$ respectively. The mass associated with the identification operation is $\boldsymbol{\mu}$, the mass associated with flavoring at the i -th step is labelled as $m_F^{(i)}$, and the FI parameter associated with gauging operation at the i -th step is $\tilde{\eta}^{(i)}$. The quivers $(X^{(p_1-1)}, Y^{(p_1-1)})$ are shown in the second line of figure 22.

2. The second sequence involves $p_2 - 2$ $N_F^\alpha = 1$ flavoring-gauging operations \mathcal{O}'_j ($j = 1, \dots, p_2 - 2$), where \mathcal{O}'_1 acts on the $U(1)_{l_1}$ flavor node of the quiver $X^{(p_1-1)}$, while

\mathcal{O}'_j for $j \geq 2$ acts on the new flavor node generated by the operation \mathcal{O}'_{j-1} in the previous step. We will denote these quivers as:

$$X^{(p_1-1,j)} = \mathcal{O}'_j \circ \mathcal{O}'_{j-1} \circ \dots \circ \mathcal{O}'_2 \circ \mathcal{O}'_1(X^{(p_1-1)}), \quad (4.57)$$

$$Y^{(p_1-1,j)} = \tilde{\mathcal{O}}'_i \circ \tilde{\mathcal{O}}'_{i-1} \circ \dots \circ \tilde{\mathcal{O}}'_2 \circ \tilde{\mathcal{O}}'_1(Y^{(p_1-1)}), \quad (4.58)$$

and the associated $\mathcal{N} = 4$ -preserving deformations will be denoted as $(\mathbf{m}^{(p_1-1,j)}, \boldsymbol{\eta}^{(p_1-1,j)})$ and $(\mathbf{m}'^{(p_1-1,j)}, \boldsymbol{\eta}'^{(p_1-1,j)})$ respectively. The mass associated with the flavoring operation at the j -th step is $x_F^{(j)}$, and the FI parameter associated with the gauging operation at the j -th step is $\xi^{(j)}$. The quivers $(X^{(p_1-1,p_2-2)}, Y^{(p_1-1,p_2-2)})$ are shown in the third line of figure 22.

3. In the final step, we implement an identification-gauging operation \mathcal{O}'' on the $X^{(p_1-1,p_2-2)}$ involving the $U(1)_{l_2}$ flavor node and the $U(1)$ flavor node generated by the operation \mathcal{O}'_{p_2-2} in the previous step. This leads to the quivers (X', Y') in figure 20, i.e.

$$X' = \mathcal{O}''(X^{(p_1-1,p_2-2)}), \quad Y' = \tilde{\mathcal{O}}''(Y^{(p_1-1,p_2-2)}). \quad (4.59)$$

We will denote the $\mathcal{N} = 4$ -preserving deformations of the dual theories as $(\mathbf{m}, \boldsymbol{\eta})$ and $(\mathbf{m}', \boldsymbol{\eta}')$ respectively. The mass associated with the identification operation is labelled as $\tilde{\mu}$, and the FI parameter is labelled as $\xi^{(p_2-1)}$.

Let us now work out the dual quivers at each step outlined above, using the dual partition functions for Abelian S -type operations derived in section 4.1.

- Consider the first sequence of operations on the theory X . Let us define the variables $\{\mathbf{u}^\beta\}$, which correspond to the $U(1)_1 \times U(1)_{n-1}$ mass parameters of the quiver X as:

$$u^1 = m_1, \quad u^2 = m_5, \quad (4.60)$$

and implement the S -type operation \mathcal{O}_1 on the relevant flavor nodes of X (the permutation matrices $\{\mathcal{P}_\beta\}$ are again trivial in this case). The partition function of the dual quiver $\tilde{\mathcal{O}}_1(Y) = Y^{(1)}$ is then given by the expressions (4.38)–(4.39) as follows:

$$\begin{aligned} & Z^{\tilde{\mathcal{O}}_1(Y)}(\mathbf{m}'^{(1)}, \boldsymbol{\eta}'^{(1)}) \quad (4.61) \\ &= \int \prod_{\gamma'=1}^4 [d\sigma^{\gamma'}] Z_{\tilde{\mathcal{O}}_1(Y)}^{\text{hyper}}(\{\sigma^{\gamma'}\}, \tilde{\boldsymbol{\eta}}^{(1)}, \mathbf{t}) Z_{\text{int}}^{(Y)}(\{\sigma^{\gamma'}\}, -\mathbf{t}, \{u^\beta = \mu^\beta + m_F^{(1)}\}, m_2, m_4), \\ &= \int \prod_{\gamma'=1}^4 [d\sigma^{\gamma'}] Z_{\tilde{\mathcal{O}}_1(Y)}^{\text{hyper}}(\{\sigma^{\gamma'}\}, \tilde{\boldsymbol{\eta}}^{(1)}, \mathbf{t}) Z_{\text{int}}^{(Y)}(\{\sigma^{\gamma'}\}, -\mathbf{t}, \{m_F^{(1)}, m_2, 0, m_4, m_F^{(1)} + \mu\}), \end{aligned}$$

where for the second equality we have redefined the mass parameter $m_F^{(1)} \rightarrow m_F^{(1)} - \mu^1$ with $\mu = \mu^2 - \mu^1$. Following (4.39), the hypermultiplet term gives

$$Z_{\tilde{\mathcal{O}}_1(Y)}^{\text{hyper}}(\{\sigma^{\gamma'}\}, \tilde{\boldsymbol{\eta}}^{(1)}, \mathbf{t}) = Z_{1\text{-loop}}^{\text{bif}} \left(\sigma^1, \sigma^4, -\tilde{\boldsymbol{\eta}}^{(1)} - \sum_{\beta} b_\beta^l t_l \right). \quad (4.62)$$

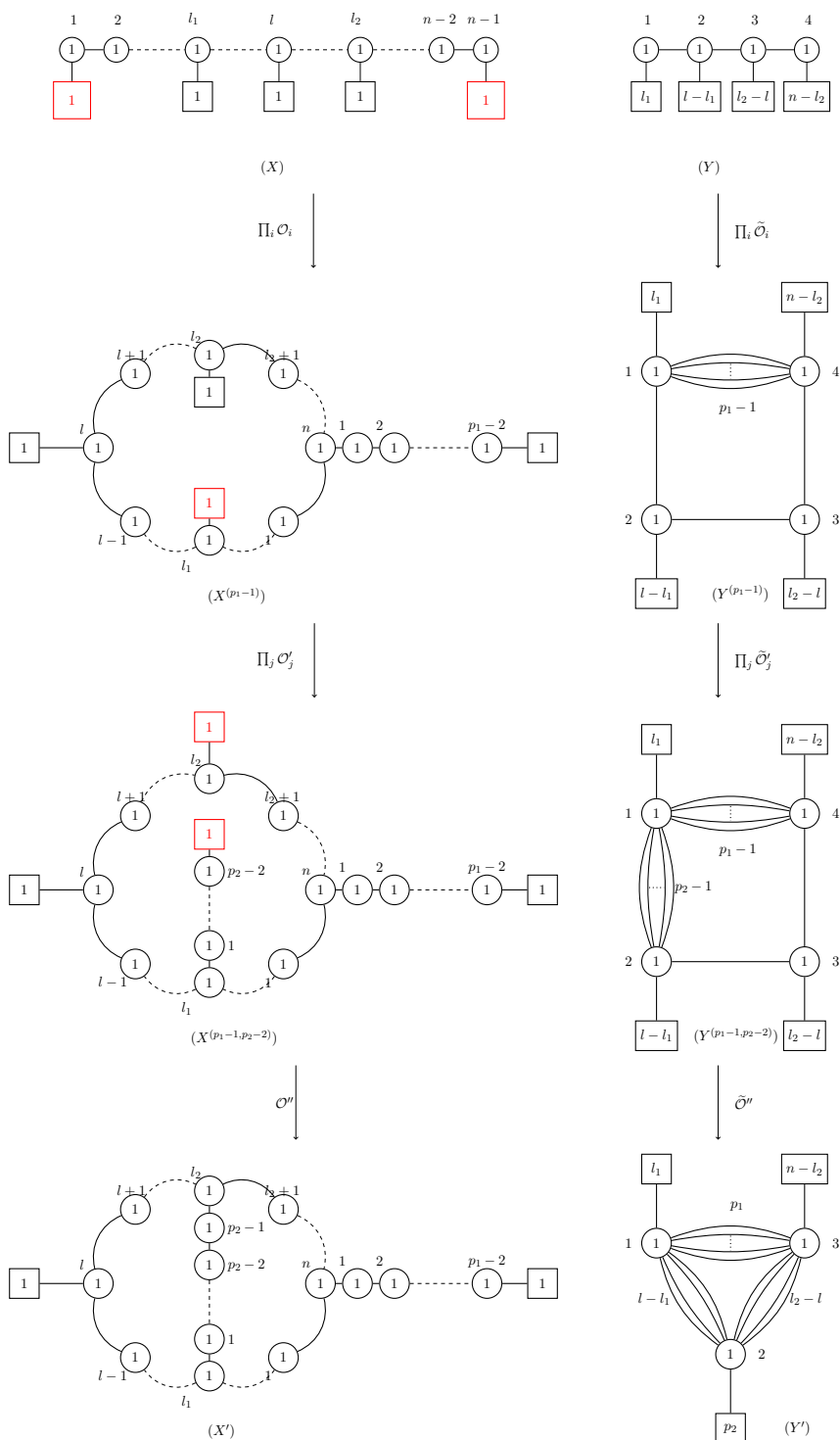

Figure 22. The quiver (X') and its mirror dual (Y') in figure 20 is generated by a sequence of elementary S -type operations on different nodes. In each step, the flavor node(s) on which the S -type operation acts is shown in red.

The dual operation therefore amounts to adding a bifundamental hypermultiplet connecting the gauge nodes labelled 1 and 4 in quiver Y , with a mass parameter $m'_{\text{bif}1} = -\tilde{\eta}^{(1)} - \sum_{\beta} b_{\beta}^l t_l$. Next, we implement the flavoring-gauging operation \mathcal{O}_2 on the quiver $X^{(1)} = \mathcal{O}_1(X)$ at the new flavor node α generated by \mathcal{O}_1 , i.e. we set

$$u^{\alpha} = m_F^{(1)}, \tag{4.63}$$

and implement the flavoring-gauging operation at α as before. The expressions (4.14)–(4.15) show that the dual quiver $\tilde{\mathcal{O}}_2(Y^{(1)}) = Y^{(2)}$ is given by adding to the quiver gauge theory $Y^{(1)}$ one extra bifundamental hypermultiplet connecting the gauge nodes labelled 1 and 4. Explicitly, (4.15) gives

$$Z_{\tilde{\mathcal{O}}_2(Y^{(1)})}(\mathbf{m}'^{(2)}, \boldsymbol{\eta}'^{(2)}) = \int \prod_{\gamma'=1}^4 [d\sigma^{\gamma'}] Z_{\tilde{\mathcal{O}}_2(Y^{(1)})}^{\text{hyper}}(\{\sigma^{\gamma'}\}, \tilde{\eta}^{(2)}, \boldsymbol{\eta}^{(1)}) Z_{\text{int}}^{(Y^{(1)})}(\{\sigma^{\gamma'}\}, \mathbf{m}'^{(1)}, \boldsymbol{\eta}'^{(1)}), \tag{4.64}$$

where $\boldsymbol{\eta}^{(1)} = \boldsymbol{\eta}^{(1)}(\mathbf{t}, \tilde{\eta}^{(1)})$, $\boldsymbol{\eta}'^{(1)} = \boldsymbol{\eta}'^{(1)}(u^{\alpha} = m_F^{(2)}, \mu, m_2, m_4)$. The function $Z_{\text{int}}^{(Y^{(1)})}$ is given by the integrand of the matrix integral on the r.h.s. of (4.61). The function g_{α} in the formula (4.14) for $Z_{\tilde{\mathcal{O}}_2(Y^{(1)})}^{\text{hyper}}$ can be read off from the FI term appearing in the r.h.s. of (4.61), i.e. $g_{\alpha}(\sigma_1, \sigma_4) = \sigma_1 - \sigma_4$. The hypermultiplet term then gives

$$Z_{\tilde{\mathcal{O}}_2(Y^{(1)})}^{\text{hyper}}(\{\sigma^{\gamma'}\}, \tilde{\eta}^{(2)}, \boldsymbol{\eta}^{(1)}) = Z_{1\text{-loop}}^{\text{bif}} \left(\sigma^1, \sigma^4, -\tilde{\eta}^{(1)} - \tilde{\eta}^{(2)} - \sum_{\beta} b_{\beta}^l t_l \right). \tag{4.65}$$

Proceeding in the same fashion, one can implement the flavoring-gauging operation successively on the new flavor node generated in the previous step. At the i -th step, the dual quiver $Y^{(i)}$ is given by adding a bifundamental hypermultiplet connecting the gauge nodes labelled 1 and 4 in the quiver $Y^{(i-1)}$. The partition function of the theory $Y^{(p_1-1)}$ is given as

$$\begin{aligned} & Z^{Y^{(p_1-1)}}(\mathbf{m}'^{(p_1-1)}, \boldsymbol{\eta}'^{(p_1-1)}) \tag{4.66} \\ &= \int \prod_{\gamma'=1}^4 [d\sigma^{\gamma'}] \prod_{i=1}^{p_1-1} Z_{1\text{-loop}}^{\text{bif}}(\sigma^1, \sigma^4, m'_{\text{bif}i}, \mathbf{m}'^{(i)}) Z_{\text{int}}^{(Y)}(\{\sigma^{\gamma'}\}, -\mathbf{t}, \{m_F^{(p_1-1)}, m_2, 0, m_4, m_F^{(p_1-1)} + \mu\}), \end{aligned}$$

which manifestly is the partition function for the quiver $Y^{(p_1-1)}$, as shown in the second line of the figure 22. The bifundamental masses \mathbf{m}'_{bif} in the above expression are given as

$$m'_{\text{bif}i} = -\sum_{k=1}^i \tilde{\eta}^{(k)} - \sum_{\beta} b_{\beta}^l t_l. \tag{4.67}$$

- Next, consider the second sequence of operations on the theory $X^{(p_1-1)}$, starting with the $U(1)_{l_1}$ flavor node shown in red in figure 22. Let us define the mass parameter u^{α} corresponding to the $U(1)_{l_1}$ flavor node as

$$u^{\alpha} = m_2, \tag{4.68}$$

and implement the flavoring-gauging operation \mathcal{O}'_1 . The partition function of the dual theory $\tilde{\mathcal{O}}'_1(Y^{(p_1-1)}) = Y^{(p_1-1,1)}$ is then given as

$$\begin{aligned} Z^{\tilde{\mathcal{O}}'_1(Y^{(p_1-1)})}(\mathbf{m}'^{(p_1-1,1)}, \boldsymbol{\eta}'^{(p_1-1,1)}) & \\ = \int \prod_{\gamma'=1}^4 [d\sigma^{\gamma'}] Z^{\text{hyper}}_{\tilde{\mathcal{O}}'_1(Y^{(p_1-1)})}(\{\sigma^{\gamma'}\}, \xi^{(1)}, \boldsymbol{\eta}^{(p_1-1)}) Z^{\text{int}}_{\text{int}}(Y^{(p_1-1)}) & (\{\sigma^{\gamma'}\}, \mathbf{m}'^{(p_1-1)}, \boldsymbol{\eta}'^{(p_1-1)}), \end{aligned} \quad (4.69)$$

where $\boldsymbol{\eta}^{(p_1-1)} = \boldsymbol{\eta}^{(p_1-1)}(\mathbf{t}, \tilde{\eta}^{(i)})$, $\boldsymbol{\eta}'^{(p_1-1)} = \boldsymbol{\eta}'^{(p_1-1)}(u^\alpha = x_F^{(1)}, \mu, m_F^{(p_1-1)}, m_4)$, and the function $Z^{\text{int}}_{\text{int}}(Y^{(p_1-1)})$ is given by the integrand on the r.h.s. of (4.66). The hypermultiplet term, computed as before from (4.14), has the form:

$$Z^{\text{hyper}}_{\tilde{\mathcal{O}}'_1(Y^{(p_1-1)})}(\{\sigma^{\gamma'}\}, \xi^{(1)}, \boldsymbol{\eta}^{(p_1-1)}) = Z^{\text{bif}}_{1\text{-loop}}(\sigma^1, \sigma^2, \xi^{(1)} + b_2^l \eta_l^{(p_1-1)}), \quad (4.70)$$

which implies that the dual operation $\tilde{\mathcal{O}}'_1$ on theory $Y^{(p_1-1)}$ simply amounts to adding a bifundamental hypermultiplet connecting the gauge nodes labelled 1 and 2 in $Y^{(p_1-1)}$. Proceeding as before, one can now perform the flavoring-gauging operation on the new U(1) flavor node, with mass parameter $x_F^{(1)}$, and repeat this operation $p_2 - 2$ times. The resultant dual theory $Y^{(p_1-1, p_2-2)}$ can be read off from the partition function:

$$\begin{aligned} Z^{Y^{(p_1-1, p_2-2)}} &= \int \prod_{\gamma'=1}^4 [d\sigma^{\gamma'}] \prod_{j=1}^{p_2-2} Z^{\text{bif}}_{1\text{-loop}}(\sigma^1, \sigma^2, m_{\text{bif } j}^{(12)}) \prod_{i=1}^{p_1-1} Z^{\text{bif}}_{1\text{-loop}}(\sigma^1, \sigma^4, m_{\text{bif } i}^{(14)}) \\ &\times Z^{\text{int}}_{\text{int}}(Y^{(p_1-1, p_2-2)})(\{\sigma^{\gamma'}\}, -\mathbf{t}, \{m_F^{(p_1-1)}, x_F^{(p_2-2)}, 0, m_4, m_F^{(p_1-1)} + \mu\}), \end{aligned} \quad (4.71)$$

which manifestly reproduces the quiver gauge theory $Y^{(p_1-1, p_2-2)}$ in the third line of figure 22. The bifundamental masses $m_{\text{bif}}^{(12)}$ in the above expression are given as

$$m_{\text{bif } j}^{(12)} = \sum_{k=1}^j \xi^{(k)} + b_2^l \eta_l^{(p_1-1)}. \quad (4.72)$$

- Finally, consider the identification-gauging operation on the theory $X^{(p_1-1, p_2-2)}$, involving the two U(1) flavor nodes shown in red in figure 22. Let us define the variables $\{u^{\beta'}\}$ as

$$u^1 = x_F^{(p_2-2)}, \quad u^2 = m_4, \quad (4.73)$$

and implement the identification-gauging operation \mathcal{O}'' . The dual, given by the general expression (4.25), is an ungauging operation on $Y^{(p_1-1, p_2-2)}$. From (4.71) and (4.25), the partition function of the theory $\tilde{\mathcal{O}}''(Y^{(p_1-1, p_2-2)})$ is given as

$$\begin{aligned} Z^{\tilde{\mathcal{O}}''(Y^{(p_1-1, p_2-2)})} &= \int \prod_{\gamma'=1}^4 [d\sigma^{\gamma'}] \prod_{j=1}^{p_2-2} Z^{\text{bif}}_{1\text{-loop}}(\sigma^1, \sigma^2, m_{\text{bif } j}^{(12)}) \prod_{i=1}^{p_1-1} Z^{\text{bif}}_{1\text{-loop}}(\sigma^1, \sigma^4, m_{\text{bif } i}^{(14)}) \\ &\times Z^{\text{int}}_{\text{int}}(Y^{(p_1-1, p_2-2)})(\{\sigma^{\gamma'}\}, -\mathbf{t}, \{m_F^{(p_1-1)}, \tilde{\mu}^1, 0, \tilde{\mu}^2, m_F^{(p_1-1)} + \mu\}) \\ &\times \delta\left(\xi^{(p_2-1)} + \sum_{\beta'} b_{\beta'}^l \eta_l^{(p_1-1, p_2-2)} + \sigma_2 + \sigma_4 - \sigma_1 - \sigma_3\right). \end{aligned} \quad (4.74)$$

To read off the precise Lagrangian for $\tilde{\mathcal{O}}''(Y^{(p_1-1, p_2-2)})$, we eliminate σ_2 using the delta function, and make the following change of variables:

$$\tilde{\sigma}^1 = \sigma^1, \quad \tilde{\sigma}^2 = \sigma^4 - \sigma^3, \quad \tilde{\sigma}^3 = \sigma^4. \quad (4.75)$$

The matrix integral (4.74) can then be recast into the following form:

$$\begin{aligned} Z^{\tilde{\mathcal{O}}''(Y^{(p_1-1, p_2-2)})} &= \int \prod_{\gamma'=1}^3 [d\tilde{\sigma}^{\gamma'}] Z_{\text{FI}}(\{\tilde{\sigma}^{\gamma'}\}, m_F^{(p_1-1)}, \tilde{\mu}, \mu) \prod_{i=1}^{l-l_1} Z_{1\text{-loop}}^{\text{bif}}(\tilde{\sigma}^1, \tilde{\sigma}^2, m_{\text{bif } i}^{\prime(12)}) \\ &\times \prod_{j=1}^{l_2-l} Z_{1\text{-loop}}^{\text{bif}}(\tilde{\sigma}^2, \tilde{\sigma}^3, m_{\text{bif } j}^{\prime(23)}) \prod_{k=1}^{p_1} Z_{1\text{-loop}}^{\text{bif}}(\tilde{\sigma}^3, \tilde{\sigma}^1, m_{\text{bif } k}^{\prime(31)}) \prod_{i_1=1}^{l_1} Z_{1\text{-loop}}^{\text{fund}}(\tilde{\sigma}^1, m_{\text{fund } i_1}^{\prime(1)}) \\ &\times \prod_{i_2=1}^{p_2} Z_{1\text{-loop}}^{\text{fund}}(\tilde{\sigma}^2, m_{\text{fund } i_2}^{\prime(2)}) \prod_{i_3=1}^{n-l_2} Z_{1\text{-loop}}^{\text{fund}}(\tilde{\sigma}^3, m_{\text{fund } i_3}^{\prime(3)}), \end{aligned} \quad (4.76)$$

$$Z_{\text{FI}}(\{\tilde{\sigma}^{\gamma'}\}, m_F^{(p_1-1)}, \tilde{\mu}, \mu) = e^{2\pi i m_F^{(p_1-1)} \tilde{\sigma}^1} e^{2\pi i \tilde{\mu} \tilde{\sigma}^2} e^{-2\pi i (\mu + m_F^{(p_1-1)}) \tilde{\sigma}^3}, \quad \tilde{\mu} = \tilde{\mu}^2 - \tilde{\mu}^1. \quad (4.77)$$

The matrix integral (4.76) manifestly reproduces the partition function of the quiver Y' in the final line of figure 22. The mirror map for the dual pair (X', Y') can be summarized as follows. The mass parameters of theory Y' , associated with the bifundamental and fundamental hypermultiplets, can be written as linear functions of the FI parameters of X' :

$$m_{\text{bif } i}^{\prime(12)} = -t_{l_1+i} + \delta + \delta_2 - \delta_1, \quad i = 1, \dots, l-l_1, \quad (4.78)$$

$$m_{\text{bif } j}^{\prime(23)} = -t_{l+j} + \delta_3 - \delta_2, \quad j = 1, \dots, l_2-l, \quad (4.79)$$

$$m_{\text{bif } k}^{\prime(31)} = \begin{cases} (\sum_{k_1=1}^k \tilde{\eta}^{(k_1)} + \sum_{\beta=1,5} b_{\beta}^l t_l) + \delta_3 - \delta_1, & \text{if } k = 1, \dots, p_1-1 \\ \delta + \delta_3 - \delta_1, & \text{if } k = p_1, \end{cases} \quad (4.80)$$

$$m_{\text{fund } i_1}^{\prime(1)} = -t_{i_1} + \delta_1, \quad i_1 = 1, \dots, l_1, \quad (4.81)$$

$$m_{\text{fund } i_2}^{\prime(2)} = \begin{cases} (\sum_{j_2=1}^{i_2} \xi^{(j_2)} + b_2^l t_l) - \delta - \delta_2, & \text{if } i_2 = 1, \dots, p_2-2 \\ -\delta - \delta_2, & \text{if } i_2 = p_2-1, \\ -\delta_2, & \text{if } i_2 = p_2, \end{cases} \quad (4.82)$$

$$m_{\text{fund } i_3}^{\prime(3)} = -t_{l_2+i_3} - \delta_3, \quad i_3 = 1, \dots, n-l_2, \quad (4.83)$$

where $\delta = \sum_j^{p_2-1} \xi^{(j)} + \sum_{\beta=2,4} b_{\beta}^l t_l$, and $\delta_{1,2,3}$ are chosen such that $\sum_{i_1} m_{\text{fund } i_1}^{\prime(1)} = \sum_{i_2} m_{\text{fund } i_2}^{\prime(2)} = \sum_{i_3} m_{\text{fund } i_3}^{\prime(3)} = 0$. The FI parameters of the theory Y' are also given in terms of the mass parameters of X' :

$$\eta^1 = m_F^{(p-1)}, \quad \eta^2 = \tilde{\mu}, \quad \eta^3 = -(m_F^{(p-1)} + \mu). \quad (4.84)$$

Written in this fashion, the fundamental mass parameters of Y' manifestly live in the Cartan subalgebra of $\text{SU}(l_1) \times \text{SU}(p_2) \times \text{SU}(n-l_2)$, while the bifundamental masses parametrize the Cartan subalgebra of $\text{U}(l-l_1) \times \text{U}(l_2-l) \times \text{U}(p_1)$. Combined together, the masses parametrize the Cartan subalgebra of the Higgs branch global symmetry

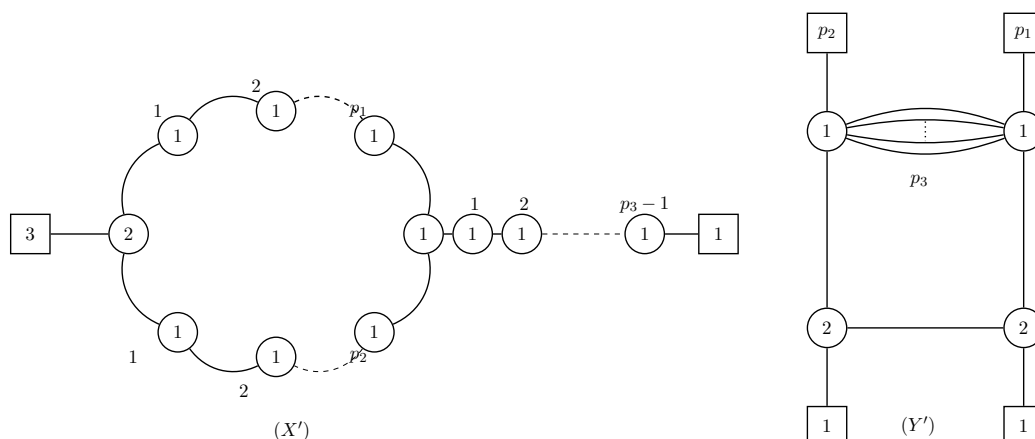

Figure 23. An infinite family of mirror duals labelled by the positive integers (p_1, p_2, p_3) subject to the constraints $p_1 \geq 1$, $p_2 \geq 1$, and $p_3 > 1$.

group of Y' , i.e. $G_H^{Y'} = \text{SU}(l_1) \times \text{SU}(p_2) \times \text{SU}(n - l_2) \times \text{U}(l - l_1) \times \text{U}(l_2 - l) \times \text{U}(p_1)$, while the FI parameters live in the Cartan subalgebra of the Coulomb branch global symmetry $G_C^{Y'} = \text{U}(1)^3$.

4.3 Examples of non-Abelian quiver pairs

4.3.1 Family III $_{[p_1, p_2, p_3]}$: a single closed loop with bifundamental matter attached to a linear quiver tail

The first example in the class of non-Abelian mirrors is the infinite family of mirror duals shown in figure 23, labelled by three positive integers (p_1, p_2, p_3) with the constraints $p_1 \geq 1$, $p_2 \geq 1$, and $p_3 > 1$. The theory X' has the shape of a single closed loop attached to a linear quiver tail, where the loop has a single $\text{U}(2)$ gauge node and $p_1 + p_2 + 1$ $\text{U}(1)$ gauge nodes. The dual theory Y' is a quiver with four gauge nodes, two of which are connected by multiple edges. The dimensions of the respective Higgs and Coulomb branches, and the associated global symmetries are shown in table 7.

The quiver pair (X', Y') in figure 23 can be generated from the linear quiver pair (X, Y) in figure 24 by a sequence of elementary Abelian operations on X and the dual operations on Y , as shown in figure 25. The Higgs branch global symmetry of X is given by $G_H^X = (\text{U}(1) \times \text{U}(3) \times \text{U}(1))/\text{U}(1)$. We choose to quotient with the overall $\text{U}(1)$ such that $G_H^X = \text{U}(1) \times \text{SU}(3) \times \text{U}(1)$. Using the notation introduced in section 2.4, the mass parameters are labelled as $\mathbf{m} = (m_1, m_2, m_3, m_4, m_5)$, and the quotient by the overall $\text{U}(1)$ factor in the flavor symmetry of quiver X can be implemented by the constraint $m_2 + m_3 + m_4 = 0$. The $\text{U}(1) \times \text{U}(1)$ subgroup of the flavor symmetry of X can then be identified with the two terminal $\text{U}(1)$ flavor nodes, parametrized by the independent (m_1, m_5) .

To obtain X' from X , we first perform an identification-flavoring-gauging operation \mathcal{O}_1 on the flavor nodes (marked in red) at the two ends of the quiver X , with $N_F^\alpha = 1$. This is followed by a sequence of flavoring-gauging operations $\{\mathcal{O}_i\}$ ($i = 2, \dots, p_3$), with $N_F^\alpha = 1$, implemented at the new flavor node obtained in the previous step. The procedure

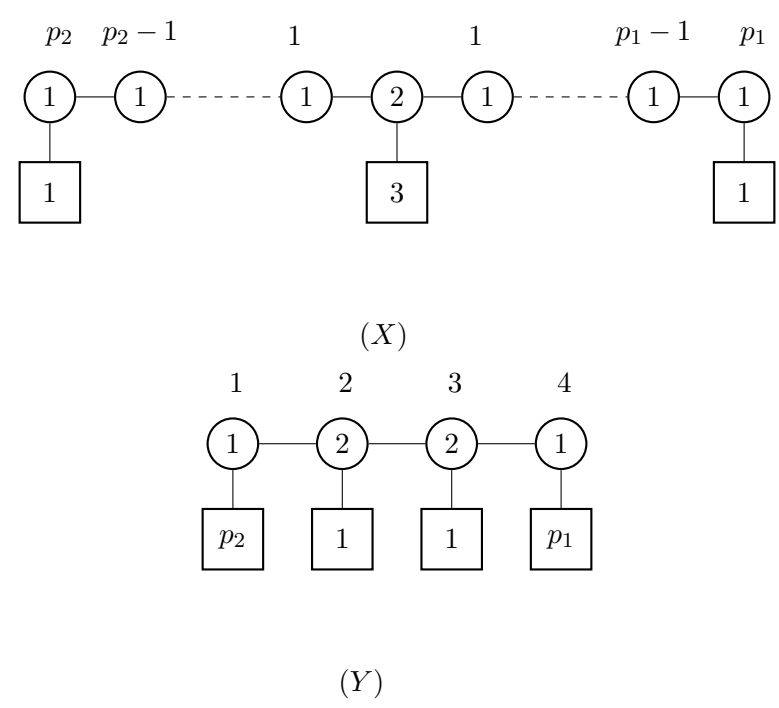

Figure 24. Pair of linear quivers with U(1) gauge groups which generate the 3d mirrors in figure 23.

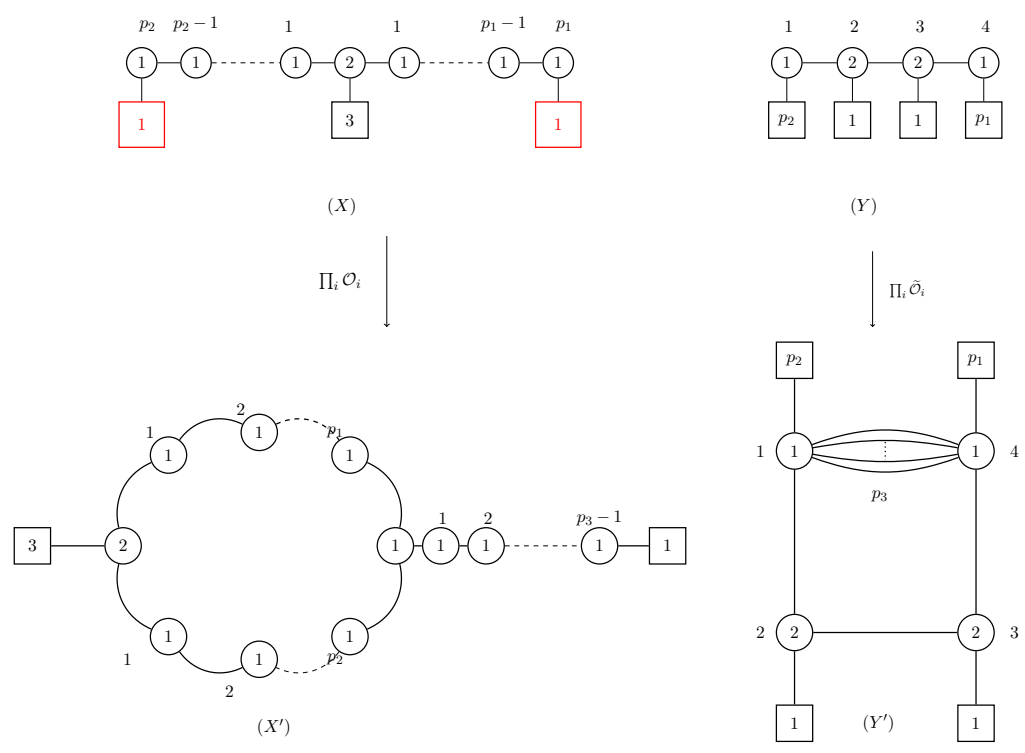

Figure 25. The quiver (X') and its mirror dual (Y') in figure 23 is generated by a sequence of elementary S-type operations on different nodes. In each step, the flavor node(s) on which the S-type operation acts is shown in red.

Moduli space data	Theory X'	Theory Y'
$\dim \mathcal{M}_H$	6	$2 + p_1 + p_2 + p_3$
$\dim \mathcal{M}_C$	$2 + p_1 + p_2 + p_3$	6
G_H	$U(3) \times U(1)$	$SU(p_1) \times SU(p_2) \times SU(p_3) \times U(1)^4$
G_C	$SU(p_1) \times SU(p_2) \times SU(p_3) \times U(1)^4$	$U(3) \times U(1)$

Table 7. Summary table for the moduli space dimensions and global symmetries for the mirror pair in figure 23.

is precisely the same as the ones described for Family I in section 4.2.1. As before, we adopt the notation:

$$X^{(i)} = \mathcal{O}_i \circ \mathcal{O}_{i-1} \circ \dots \circ \mathcal{O}_2 \circ \mathcal{O}_1(X), \quad (4.85)$$

$$Y^{(i)} = \tilde{\mathcal{O}}_i \circ \tilde{\mathcal{O}}_{i-1} \circ \dots \circ \tilde{\mathcal{O}}_2 \circ \tilde{\mathcal{O}}_1(Y), \quad (4.86)$$

where \mathcal{O}_1 is an identification-flavoring-gauging operation, and \mathcal{O}_i ($i > 1$) are flavoring-gauging operations. In this notation, we have

$$X' = X^{(p_3)}, \quad Y' = Y^{(p_3)}. \quad (4.87)$$

The $\mathcal{N} = 4$ -preserving deformations of the quivers $X^{(i)}$ and $Y^{(i)}$ are denoted as $(\mathbf{m}^{(i)}, \boldsymbol{\eta}^{(i)})$ and $(\mathbf{m}'^{(i)}, \boldsymbol{\eta}'^{(i)})$ respectively. We will denote the deformation parameters of the dual theories X' and Y' as $(\mathbf{m}, \boldsymbol{\eta})$ and $(\mathbf{m}', \boldsymbol{\eta}')$ respectively, which obviously implies

$$(\mathbf{m}, \boldsymbol{\eta}) = (\mathbf{m}^{(p_3)}, \boldsymbol{\eta}^{(p_3)}), \quad (\mathbf{m}', \boldsymbol{\eta}') = (\mathbf{m}'^{(p_3)}, \boldsymbol{\eta}'^{(p_3)}). \quad (4.88)$$

Finally, the masses associated with the identification operation are parametrized as $\boldsymbol{\mu}$, while the mass associated with flavoring operation at the i -th step is $m_F^\alpha = m_F^{(i)}$. The FI parameter associated to the gauging operation at the i -th step is $\eta_\alpha = \tilde{\eta}^{(i)}$.

Following the notation in section 4.1, we define the variables $\{\mathbf{u}^\beta\}$, which parametrize the $U(1) \times U(1)$ mass parameters of the quiver X :

$$u^1 = m_1, \quad u^2 = m_5, \quad (4.89)$$

and implement the operations $\{\mathcal{O}_i\}$, as shown in figure 25. Since the computation is very similar to the one discussed in section 4.2.1, we simply present the answer. Following the general formulae in (4.38)–(4.39) and (4.14)–(4.15), the partition function of the theory $Y^{(p_3)}$ is given as

$$\begin{aligned} & Z^{Y^{(p_3)}}(\mathbf{m}'^{(p_3)}, \boldsymbol{\eta}'^{(p_3)}) \\ &= \int \prod_{\gamma'=1}^4 [d\boldsymbol{\sigma}^{\gamma'}] \prod_{i=1}^{p_3} Z_{1\text{-loop}}^{\text{bif}}(\sigma^1, \sigma^4, m'_{\text{bif } i}{}^{(14)}) Z_{\text{int}}^{(Y)}(\{\boldsymbol{\sigma}^{\gamma'}\}, -\mathbf{t}, \{m_F^{(p_3)}, m_2, m_3, m_4, m_F^{(p_3)} + \boldsymbol{\mu}\}), \end{aligned} \quad (4.90)$$

which manifestly is the partition function for the quiver Y' , as shown in the second line of the figure 25. The bifundamental masses \mathbf{m}'_{bif} in the above expression are given as

$$m'_{\text{bif } i}{}^{(14)} = - \sum_{k=1}^i \tilde{\eta}^{(k)} - \sum_{\beta=1,5} b_\beta^l t_l. \quad (4.91)$$

After a change of integration variables, the mirror map for the dual pair (X', Y') can be summarized as follows. The mass parameters of theory Y' , associated with the bifundamental and fundamental hypermultiplets, can be written as linear functions of the FI parameters of X' :

$$m_{\text{bif } i}^{(14)} = -\sum_{k=1}^i \tilde{\eta}^{(k)} - \sum_{\beta=1,5} b_{\beta}^l t_l, \tag{4.92}$$

$$m_{\text{bif}}^{(12)} = 0, m_{\text{bif}}^{(23)} = 0, m_{\text{bif}}^{(34)} = 0, \tag{4.93}$$

$$m_{\text{fund } i_1}^{11} = -t_{i_1} + \delta, \quad i_1 = 1, \dots, p_2, \tag{4.94}$$

$$m_{\text{fund}}^{22} = -t_{p_2+1} + \delta, \tag{4.95}$$

$$m_{\text{fund}}^{33} = -t_{p_2+2} + \delta, \tag{4.96}$$

$$m_{\text{fund } i_2}^{44} = -t_{p_2+2+i_4} + \delta, \quad i_4 = 1, \dots, p_1, \tag{4.97}$$

where we choose δ such that $\delta = \frac{\sum_{i_1} t_{i_1}}{p_2}$. The FI parameters of the theory Y' are also given in terms of the mass parameters of X' :

$$\eta^{11} = m_F^{(p_3)} - m_2, \eta^{22} = m_2 - m_3, \eta^{33} = m_3 - m_4, \eta^{44} = m_4 - (m_F^{(p-1)} + \mu). \tag{4.98}$$

The mass parameters of Y' manifestly live in the Cartan subalgebra of the Higgs branch global symmetry $G_H^{Y'} = \text{SU}(p_2) \times \text{U}(p_3) \times \text{U}(p_1) \times \text{U}(1)^2$, while the FI parameters live in the Cartan subalgebra of the Coulomb branch global symmetry $G_C^{Y'} = \text{U}(3) \times \text{U}(1)$. The Coulomb branch global symmetry can be read off from the observation that Y' contains a balanced sub-quiver with two gauge nodes (labelled 2 and 3) which gives an $\text{SU}(3)$ factor, along with two unbalanced nodes which contribute a $\text{U}(1)$ factor each.

4.3.2 Family IV $_{[p_1, p_2, p_3]}$: a single closed loop with bifundamental and rank-2 antisymmetric matter attached to a linear quiver tail

The second example in the class of non-Abelian mirrors is the infinite family of mirror duals shown in figure 26, labelled by three positive integers (p_1, p_2, p_3) with the constraints $p_1 \geq 1$, $p_2 \geq 1$, and $p_3 > 1$. The theory X' has the shape of a single closed loop attached to a linear quiver tail, where the loop has a single $\text{U}(2)$ gauge node and $p_1 + p_2 + 1$ $\text{U}(1)$ gauge nodes. One of the hypermultiplets in the loop transforms in the rank-2 antisymmetric representation of $\text{U}(2)$ (i.e. it is charged +2 under the $\text{U}(1)$ subgroup of $\text{U}(2)$ and singlet under the $\text{SU}(2)$) and is charged +1 under an adjacent $\text{U}(1)$, while all the other hypermultiplets in the loop transform in the bifundamental representations as shown. The dual theory Y' is a quiver with four gauge nodes, two of which are connected by multiple edges. The dimensions of the respective Higgs and Coulomb branches, and the associated global symmetries are shown in table 8.

The quiver pair (X', Y') in figure 26 can be generated from the quiver pair (X, Y) in figure 27 by a series of elementary Abelian S -type operations on X and the dual operations on Y (shown in figure 29), which we shall describe momentarily. Note that the quiver pair

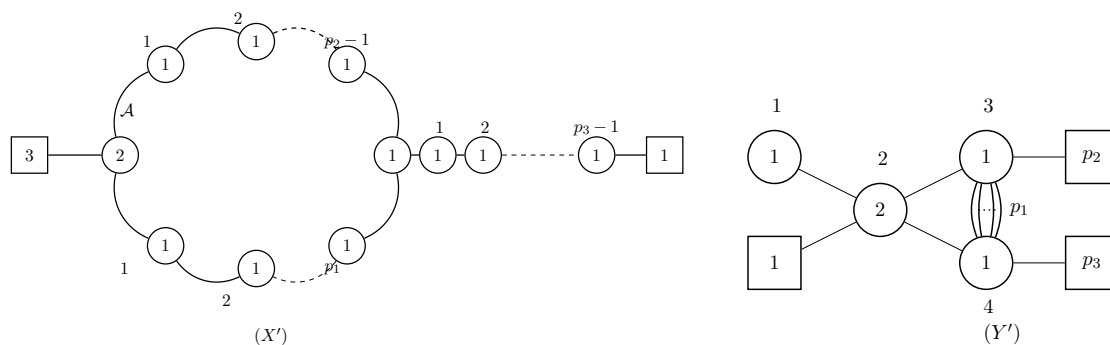

Figure 26. An infinite family of mirror duals labelled by the positive integers (p_1, p_2, p_3) subject to the constraints $p_1 \geq 1$, $p_2 \geq 1$, and $p_3 > 1$. The label \mathcal{A} denotes a hypermultiplet transforming in a rank-2 antisymmetric representation of $U(2)$ and having charge 1 under $U(1)_1$.

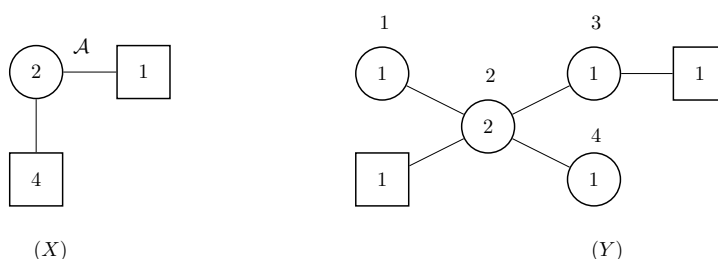

Figure 27. Mirror duals involving a D_4 quiver on one side. This dual pair (X, Y) will be our starting point for arriving at the duality in figure 26. The dual pair can, in turn, be obtained from a pair of linear quivers as discussed in section A.1.

(X, Y) are not linear quivers, but can be easily generated from a pair of linear quivers using a single Abelian gauging operation, as shown in figure 28 and discussed in section A.1.¹⁵

The Higgs branch global symmetry of X is given by $G_H^X = (U(4) \times U(1)_{\mathcal{A}}) / U(1)$, where $U(1)_{\mathcal{A}}$ is the flavor symmetry associated with the antisymmetric hypermultiplet, and the Coulomb branch global symmetry is $G_C^X = U(1)$. The fundamental mass parameters are labelled as (m_1, m_2, m_3, m_4) , and the mass parameter for the antisymmetric hypermultiplet as $m_{\mathcal{A}}$. The quotient by the overall $U(1)$ factor can be implemented either by the constraint $\sum_{i=1}^4 m_i = 0$, or the constraint $m_{\mathcal{A}} = 0$. The Coulomb branch global symmetry of Y is clearly given by $G_C^Y = SU(4) \times U(1)$, where the $SU(4)$ factor arises from the balanced linear subquiver of Y , consisting of the gauge nodes labelled 1, 2 and 3 in figure 27. The Cartan subalgebra of G_C^Y is parametrized by the FI parameters $\{\eta'_l\}_{l=1, \dots, 4}$. The Higgs branch global symmetry of X is given by $G_H^Y = (U(1)_2 \times U(1)_3) / U(1)$, where the Cartan of $U(1)_2 \times U(1)_3$ is parametrized by (m'_2, m'_3) . We will implement the $U(1)$ quotient by choosing $m'_3 = 0$. The mirror map for the dual pair (X, Y) relating masses and FI parameters across the duality is then given as follows (simply inverting the relations (A.14)–(A.16) and interchanging the

¹⁵In the notation of section A.1, $X_{\text{here}} = Y''_{\text{there}}$, and $Y_{\text{here}} = X'_{\text{there}}$. One can also think of generating the dual pair in figure 26 from a pair of linear quivers by first implementing a gauging operation of a Coulomb branch global symmetry and then implementing a sequence of different Abelian S -type operations which gauge a subgroup of the Higgs branch global symmetry.

Moduli space data	Theory X'	Theory Y'
$\dim \mathcal{M}_H$	5	$1 + p_1 + p_2 + p_3$
$\dim \mathcal{M}_C$	$1 + p_1 + p_2 + p_3$	5
G_H	$SU(3) \times U(1)^2$	$SU(p_1) \times SU(p_2) \times SU(p_3) \times U(1)^3$
G_C	$SU(p_1) \times SU(p_2) \times SU(p_3) \times U(1)^3$	$SU(3) \times U(1)^2$

Table 8. Summary table for the moduli space dimensions and global symmetries for the mirror pair in figure 26.

primed and unprimed parameters):

$$\eta'_l = -(m_l - m_{l+1}), \quad l = 1, 2, \quad (4.99)$$

$$\eta'_3 = -m_3 - m_4 + m_{\mathcal{A}}, \quad (4.100)$$

$$\eta'_4 = m_4 - m_3, \quad (4.101)$$

$$m'_2 = \eta, \quad m'_3 = 0, \quad (4.102)$$

where it is understood that the masses of X satisfy one of the constraints $-\sum_{i=1}^4 m_i = 0$, or $m_{\mathcal{A}} = 0$.

The theory X' can be obtained from the quiver X in three distinct set of steps, as shown in figure 29, each involving a sequence of elementary Abelian operations which we describe below:

1. We impose the constraint $m_{\mathcal{A}} = 0$, and identify the Higgs branch global symmetry $G_H^X = U(4)$ with the $U(4)$ flavor node corresponding to the fundamental hypermultiplets. Then we perform an Abelian flavoring-gauging operation $\mathcal{O}_{1\mathcal{P}}$ at the $U(4)$ flavor node, with $N_F^\alpha = 1$, with the following choice of the permutation matrix \mathcal{P} :¹⁶

$$\mathcal{P} = \begin{pmatrix} 0 & 1 & 0 & 0 \\ 0 & 0 & 1 & 0 \\ 0 & 0 & 0 & 1 \\ 1 & 0 & 0 & 0 \end{pmatrix}. \quad (4.103)$$

This is followed by a sequence of flavoring-gauging operations \mathcal{O}_i (for $i = 2, \dots, p_1$) acting at the new $U(1)$ flavor node generated in the previous step. At each step, the flavoring operation corresponds to $N_F^\alpha = 1$. Note that only $\mathcal{O}_{1\mathcal{P}}$ depends on the permutation matrix \mathcal{P} , while the rest of the operations \mathcal{O}_i ($i > 1$) do not. We adopt the following notation for the resultant quivers and their respective duals:

$$X_{\mathcal{P}}^{(i)} = \mathcal{O}_i \circ \mathcal{O}_{i-1} \circ \dots \circ \mathcal{O}_2 \circ \mathcal{O}_{1\mathcal{P}}(X), \quad (4.104)$$

$$Y_{\mathcal{P}}^{(i)} = \tilde{\mathcal{O}}_i \circ \tilde{\mathcal{O}}_{i-1} \circ \dots \circ \tilde{\mathcal{O}}_2 \circ \tilde{\mathcal{O}}_{1\mathcal{P}}(Y), \quad (4.105)$$

¹⁶One can explicitly show that, for the other choices of the matrix \mathcal{P} , one either obtains the same dual Lagrangian Y' in figure 26, or obtains a Lagrangian which is related to Y' by some simple field redefinition.

and denote the $\mathcal{N} = 4$ -preserving deformations of the quivers $X_{\mathcal{P}}^{(i)}$ and $Y_{\mathcal{P}}^{(i)}$ as $(\mathbf{m}^{(i)}, \boldsymbol{\eta}^{(i)})$ and $(\mathbf{m}'^{(i)}, \boldsymbol{\eta}'^{(i)})$ respectively. The mass associated with flavoring at the i -th step is labelled as $m_F^{(i)}$, and the FI parameter associated with gauging operation at the i -th step is $\tilde{\eta}^{(i)}$. The quivers ($X_{\mathcal{P}}^{(p_1)}$ and its dual $Y_{\mathcal{P}}^{(p_1)}$) are shown in the second line of figure 29.

2. The Higgs branch global symmetry of the quiver $X_{\mathcal{P}}^{(p_1)}$ is $G_H^{X_{\mathcal{P}}^{(p_1)}} = (\text{U}(3) \times \text{U}(1)_{\mathcal{A}} \times \text{U}(1))/\text{U}(1)$. We will choose to implement the $\text{U}(1)$ quotient by constraining the masses of the hypers in the fundamental representation of $\text{U}(2)$, while leaving the $\text{U}(1)_{\mathcal{A}}$ and $\text{U}(1)$ masses unconstrained. Then, we perform a sequence of $N_F^\alpha = 1$ flavoring-gauging operations \mathcal{O}'_j ($j = 1, \dots, p_2 - 1$), starting at the $\text{U}(1)_{\mathcal{A}}$ node, and acting on the new $\text{U}(1)$ flavor node in the subsequent steps. We will denote these quivers as:

$$X_{\mathcal{P}}^{(p_1, j)} = \mathcal{O}'_j \circ \mathcal{O}'_{j-1} \circ \dots \circ \mathcal{O}'_2 \circ \mathcal{O}'_1(X_{\mathcal{P}}^{(p_1)}), \quad (4.106)$$

$$Y_{\mathcal{P}}^{(p_1, j)} = \tilde{\mathcal{O}}'_j \circ \tilde{\mathcal{O}}'_{j-1} \circ \dots \circ \tilde{\mathcal{O}}'_2 \circ \tilde{\mathcal{O}}'_1(Y_{\mathcal{P}}^{(p_1)}), \quad (4.107)$$

and the associated $\mathcal{N} = 4$ -preserving deformations will be denoted as $(\mathbf{m}^{(p_1, j)}, \boldsymbol{\eta}^{(p_1, j)})$ and $(\mathbf{m}'^{(p_1, j)}, \boldsymbol{\eta}'^{(p_1, j)})$ respectively. The mass associated with the flavoring operation at the j -th step is $x_F^{(j)}$, and the FI parameter associated with the gauging operation at the j -th step is $\xi^{(j)}$. The resultant quiver $X_{\mathcal{P}}^{(p_1, p_2-1)}$ and its dual $Y_{\mathcal{P}}^{(p_1, p_2-1)}$ are shown in the third line of figure 29.

3. In the final step, we implement an $N_F^\alpha = 1$ identification-flavoring-gauging operation \mathcal{O}''_1 on the two $\text{U}(1)$ flavor nodes of $X_{\mathcal{P}}^{(p_1, p_2-1)}$, shown in red in the third line of figure 29. This is again followed by a sequence of $N_F^\alpha = 1$ flavoring-gauging operations \mathcal{O}''_k ($k = 2, \dots, p_3$), starting with the new $\text{U}(1)$ flavor node generated by \mathcal{O}''_1 . We will denote these quivers as:

$$X_{\mathcal{P}}^{(p_1, p_2-1, k)} = \mathcal{O}''_k \circ \mathcal{O}''_{k-1} \circ \dots \circ \mathcal{O}''_2 \circ \mathcal{O}''_1(X_{\mathcal{P}}^{(p_1, p_2-1)}), \quad (4.108)$$

$$Y_{\mathcal{P}}^{(p_1, p_2-1, k)} = \tilde{\mathcal{O}}''_k \circ \tilde{\mathcal{O}}''_{k-1} \circ \dots \circ \tilde{\mathcal{O}}''_2 \circ \tilde{\mathcal{O}}''_1(Y_{\mathcal{P}}^{(p_1, p_2-1)}), \quad (4.109)$$

and the associated $\mathcal{N} = 4$ -preserving deformations will be denoted as $(\mathbf{m}^{(p_1, p_2-1, k)}, \boldsymbol{\eta}^{(p_1, p_2-1, k)})$ and $(\mathbf{m}'^{(p_1, p_2-1, k)}, \boldsymbol{\eta}'^{(p_1, p_2-1, k)})$ respectively. The mass associated with the flavoring operation at the k -th step is $y_F^{(k)}$, and the FI parameter associated with the gauging operation at the k -th step is $\zeta^{(k)}$. The mass associated with the identification operation is $\boldsymbol{\mu}$. The resultant quiver $X_{\mathcal{P}}^{(p_1, p_2-1, p_3)} = X'$ and its dual $Y_{\mathcal{P}}^{(p_1, p_2-1, p_3)} = Y'$ are shown in the fourth line of figure 29.

Let us now work out the dual quivers at each step outlined above, using the general prescriptions for the dual partition functions for Abelian S -type operations, derived in section 4.1.

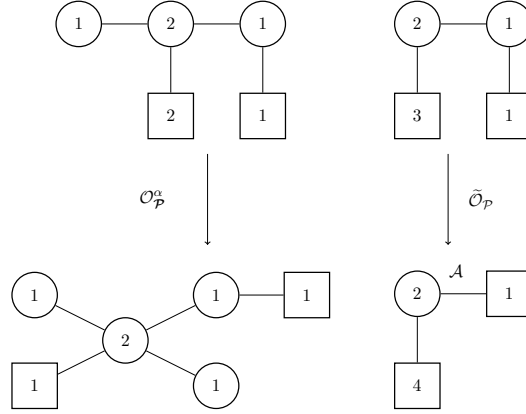

Figure 28. The mirror dual pair (X, Y) in figure 27 can be derived from a pair of linear quivers shown in the top line by an Abelian gauging operation. The details of the computation can be found in section A.1.

- Consider the first sequence of operations on the theory X at the $U(4)$ flavor node α . Recall that the partition function of the theory Y is given as¹⁷

$$\begin{aligned}
 Z^{(Y)}(\mathbf{m}', \boldsymbol{\eta}') &= \int \prod_{\gamma'=1}^4 [d\boldsymbol{\sigma}^{\gamma'}] Z_{\text{int}}^{(Y)}(\{\boldsymbol{\sigma}^{\gamma'}\}, \eta, \{m_1, m_2, m_3, m_4, m_{\mathcal{A}}\}) \\
 &= \int \prod_{\gamma'=1}^4 [d\boldsymbol{\sigma}^{\gamma'}] Z_{\text{FI}}^{(Y)}(\{\boldsymbol{\sigma}^{\gamma'}\}, \{m_1, m_2, m_3, m_4, m_{\mathcal{A}}\}) Z_{1\text{-loop}}^{(Y)}(\{\boldsymbol{\sigma}^{\gamma'}\}, \eta),
 \end{aligned} \tag{4.110}$$

where $Z_{1\text{-loop}}^{(Y)}$ can be read off from the quiver Y in figure 27. The explicit form of the FI term, using the relations (4.99)–(4.101), is as follows:

$$\begin{aligned}
 Z_{\text{FI}}^{(Y)}(\{\boldsymbol{\sigma}^{\gamma'}\}, \{m_1, m_2, m_3, m_4, m_{\mathcal{A}}\}) &= e^{-2\pi i \sigma_1 (m_1 - m_2)} e^{-2\pi i \text{Tr} \sigma_2 (m_2 - m_3)} \\
 &\times e^{-2\pi i \sigma_3 (m_3 + m_4 - m_{\mathcal{A}})} e^{-2\pi i \sigma_4 (m_3 - m_4)}.
 \end{aligned} \tag{4.111}$$

As discussed earlier, we will implement the overall $U(1)$ quotient for the Higgs branch global symmetry by the constraint $m_{\mathcal{A}} = 0$. Given the choice of the permutation matrix \mathcal{P} in (4.103), we define the variable u^α following the definition (3.1), as:

$$u^\alpha = m_4, \tag{4.112}$$

and implement the S -type operation $\mathcal{O}_{1\mathcal{P}}$ on X first. The partition function of the dual quiver $\tilde{\mathcal{O}}_{1\mathcal{P}}(Y) = Y_{\mathcal{P}}^{(1)}$ is then given by the expressions (4.15)–(4.14) as follows:

$$\begin{aligned}
 Z^{\tilde{\mathcal{O}}_{1\mathcal{P}}(Y)}(\mathbf{m}'^{(1)}, \boldsymbol{\eta}'^{(1)}) \\
 = \int \prod_{\gamma'=1}^4 [d\boldsymbol{\sigma}^{\gamma'}] Z_{\tilde{\mathcal{O}}_{1\mathcal{P}}(Y)}^{\text{hyper}}(\{\boldsymbol{\sigma}^{\gamma'}\}, \tilde{\eta}^{(1)}, \eta) Z_{\text{int}}^{(Y)}(\{\boldsymbol{\sigma}^{\gamma'}\}, \eta, \{m_1, m_2, m_3, m_4 = m_F^{(1)}, m_{\mathcal{A}} = 0\}),
 \end{aligned} \tag{4.113}$$

¹⁷Mirror symmetry implies that the partition functions for X and Y are related in the following fashion: $Z^{(X)} = e^{2\pi i (\sum_{i=1}^4 b_i m_i + b_{\mathcal{A}} m_{\mathcal{A}}) \eta} Z^{(Y)}$, where $\{m_i, m_{\mathcal{A}}\}$ and η are the mass parameters and the FI parameter of the quiver gauge theory Y respectively.

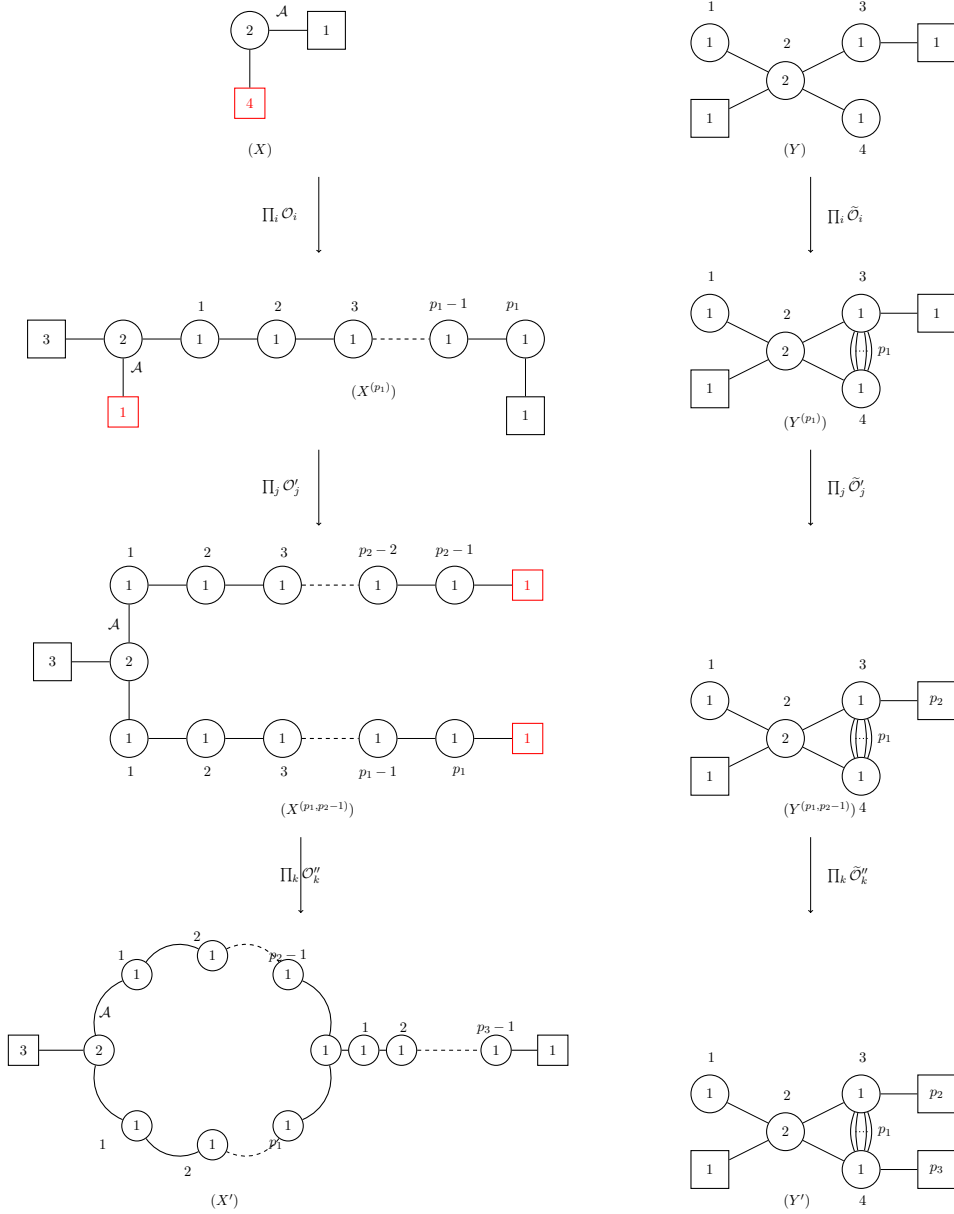

Figure 29. The quiver (X') and its mirror dual (Y') in figure 26 is generated by a sequence of elementary S -type operations on different nodes. In each step, the flavor node(s) on which the S -type operation acts is shown in red.

where the hypermultiplet term is given by (4.14). The function $g_\alpha(\{\sigma^{\gamma'}\}, \mathcal{P})$ in (4.14) can be read off from the $u^\alpha = m^4$ -dependent part of the FI term $Z_{\text{FI}}^{(Y)}$ in (4.111):

$$g_\alpha(\{\sigma^{\gamma'}\}, \mathcal{P}) = \sigma^4 - \sigma^3, \quad (4.114)$$

which leads to the hypermultiplet term:

$$Z_{\tilde{\mathcal{O}}_1 \mathcal{P}(Y)}^{\text{hyper}}(\{\sigma^{\gamma'}\}, \tilde{\eta}^{(1)}, \eta) = Z_{1\text{-loop}}^{\text{bif}}(\sigma^3, \sigma^4, \tilde{\eta}^{(1)} + b_4 \eta). \quad (4.115)$$

The dual operation therefore amounts to adding a bifundamental hypermultiplet connecting the gauge nodes labelled 3 and 4 in quiver Y , with a mass parameter $m_{\text{bif}1}^{(34)} = \tilde{\eta}^{(1)} + b_4\eta$.

Next, we implement the flavoring-gauging operation \mathcal{O}_2 on the quiver $X_{\mathcal{P}}^{(1)} = \mathcal{O}_1\mathcal{P}(X)$ at the new flavor node α generated by $\mathcal{O}_1\mathcal{P}$, i.e. we set

$$u^\alpha = m_F^{(1)}, \tag{4.116}$$

and implement the flavoring-gauging operation with $N_F^\alpha = 1$. Proceeding as before, one can show that the dual operation amounts to adding another bifundamental hypermultiplet connecting the gauge nodes labelled 3 and 4 in quiver $Y_{\mathcal{P}}^{(1)}$. Repeating this operation $p_1 - 2$ times, the partition function of the dual theory $Y_{\mathcal{P}}^{(p_1)}$ is given as

$$\begin{aligned} & Z^{Y_{\mathcal{P}}^{(p_1)}}(\mathbf{m}'^{(p_1)}, \boldsymbol{\eta}'^{(p_1)}) \\ &= \int \prod_{\gamma'=1}^4 [d\boldsymbol{\sigma}^{\gamma'}] \prod_{i=1}^{p_1} Z_{1\text{-loop}}^{\text{bif}}(\sigma^3, \sigma^4, m_{\text{bif}i}^{(34)}) Z_{\text{int}}^{(Y)}(\{\boldsymbol{\sigma}^{\gamma'}\}, \eta, \{m_1, m_2, m_3, m_4 = m_F^{(p_1)}, m_{\mathcal{A}} = 0\}), \end{aligned} \tag{4.117}$$

which manifestly is the partition function for the quiver gauge theory $Y_{\mathcal{P}}^{(p_1)}$ in the second row of the figure 29, with the bifundamental masses $m_{\text{bif}}^{(34)}$ in the above expression given as

$$m_{\text{bif}i}^{(34)} = \sum_{k=1}^i \tilde{\eta}^{(k)} + b_4\eta. \tag{4.118}$$

The Higgs branch global symmetry of the quiver $X_{\mathcal{P}}^{(p_1)}$ is $G_H^{X_{\mathcal{P}}^{(p_1)}} = (\text{U}(3) \times \text{U}(1)_{\mathcal{A}} \times \text{U}(1))/\text{U}(1)$. We can now choose to implement the $\text{U}(1)$ quotient such that $G_H^{X_{\mathcal{P}}^{(p_1)}} = \text{SU}(3) \times \text{U}(1)_{\mathcal{A}} \times \text{U}(1)$, where (m_1, m_2, m_3) parametrize the Cartan subalgebra of the $\text{SU}(3)$, while the other masses $(m_{\mathcal{A}}, m_F^{(p_1)})$ parametrize the Cartan of $\text{U}(1)_{\mathcal{A}} \times \text{U}(1)$. The dual partition function can then be rewritten as

$$\begin{aligned} & Z^{Y_{\mathcal{P}}^{(p_1)}}(\mathbf{m}'^{(p_1)}, \boldsymbol{\eta}'^{(p_1)}) \\ &= \int \prod_{\gamma'=1}^4 [d\boldsymbol{\sigma}^{\gamma'}] \prod_{i=1}^{p_1} Z_{1\text{-loop}}^{\text{bif}}(\sigma^3, \sigma^4, m_{\text{bif}i}^{(34)}) Z_{\text{int}}^{(Y)}(\{\boldsymbol{\sigma}^{\gamma'}\}, \eta, \{m_1, m_2, m_3, m_F^{(p_1)}, m_{\mathcal{A}}\}), \end{aligned} \tag{4.119}$$

where $\sum_{i=1}^3 m_i = 0$. The FI term in the partition function of the theory $Y_{\mathcal{P}}^{(p_1)}$ as well as the mirror map for the dual pair $(X_{\mathcal{P}}^{(p_1)}, Y_{\mathcal{P}}^{(p_1)})$ can be read off from (4.119) and (4.111).

- Now consider the sequence of $N_F^\alpha = 1$ flavoring-gauging operations \mathcal{O}'_j ($j = 1, \dots, p_2 - 1$). The operation \mathcal{O}'_1 acts on the $\text{U}(1)_{\mathcal{A}}$ node of the quiver $X_{\mathcal{P}}^{(p_1)}$, while the subsequent ones act on the new $\text{U}(1)$ flavor node created in the previous step. For implementing \mathcal{O}'_1 , we define:

$$u^\alpha = m_{\mathcal{A}}. \tag{4.120}$$

Following (4.14)–(4.15), the partition function of the dual theory $\tilde{\mathcal{O}}'_1(Y_{\mathcal{P}}^{(p_1)}) = Y_{\mathcal{P}}^{(p_1,1)}$ is then given as

$$\begin{aligned} & Z^{\tilde{\mathcal{O}}'_1(Y_{\mathcal{P}}^{(p_1)})}(\mathbf{m}'^{(p_1,1)}, \boldsymbol{\eta}'^{(p_1,1)}) \\ &= \int \prod_{\gamma'=1}^4 [d\boldsymbol{\sigma}^{\gamma'}] Z_{\tilde{\mathcal{O}}'_1(Y_{\mathcal{P}}^{(p_1)})}^{\text{hyper}}(\{\boldsymbol{\sigma}^{\gamma'}\}, \xi^{(1)}, \boldsymbol{\eta}^{(p_1)}) Z_{\text{int}}^{Y_{\mathcal{P}}^{(p_1)}}(\{\boldsymbol{\sigma}^{\gamma'}\}, \mathbf{m}'^{(p_1)}, \boldsymbol{\eta}'^{(p_1)}), \end{aligned} \quad (4.121)$$

where $\boldsymbol{\eta}^{(p_1)} = \boldsymbol{\eta}^{(p_1)}(\eta, \tilde{\eta}^{(i)})$, $\boldsymbol{\eta}'^{(p_1)} = \boldsymbol{\eta}'^{(p_1)}(m_1, m_2, m_3, m_F^{(p_1)}, x_F^{(1)})$, and the function $Z_{\text{int}}^{Y_{\mathcal{P}}^{(p_1)}}$ is given by the integrand on the r.h.s. of the (4.119). The hypermultiplet term can be computed as before from (4.14), where the function $g_{\alpha}(\{\boldsymbol{\sigma}^{\gamma'}\})$ can be read off from the $u^{\alpha} = m_{\mathcal{A}}$ -dependent part of the FI term in (4.117):

$$g_{\alpha}(\{\boldsymbol{\sigma}^{\gamma'}\}) = \sigma^3. \quad (4.122)$$

This leads to the hypermultiplet contribution

$$Z_{\tilde{\mathcal{O}}'_1(Y_{\mathcal{P}}^{(p_1)})}^{\text{hyper}}(\{\boldsymbol{\sigma}^{\gamma'}\}, \xi^{(1)}, \boldsymbol{\eta}^{(p_1)}) = Z_{1\text{-loop}}^{\text{fund}}(\sigma^3, -\xi^{(1)} - b_{\mathcal{A}}\eta), \quad (4.123)$$

which implies that the dual operation $\tilde{\mathcal{O}}'_1$ amounts to adding a single fundamental hyper at the gauge node labelled 3 in the quiver $Y_{\mathcal{P}}^{(p_1)}$, with a mass $m_{\text{fund } 1}^{(3)} = -\xi^{(1)} - b_{\mathcal{A}}\eta$. Proceeding with the subsequent operations \mathcal{O}'_j ($j = 2, \dots, p_2 - 1$), the theory $Y^{(p_1, p_2-1)}$ can be read off from the partition function:

$$\begin{aligned} Z^{Y_{\mathcal{P}}^{(p_1, p_2-1)}} &= \int \prod_{\gamma'=1}^4 [d\boldsymbol{\sigma}^{\gamma'}] \prod_{j=1}^{p_2-1} Z_{1\text{-loop}}^{\text{fund}}(\sigma^3, m_{\text{fund } j}^{(3)}) \prod_{i=1}^{p_1} Z_{1\text{-loop}}^{\text{bif}}(\sigma^3, \sigma^4, m_{\text{bif } i}^{(34)}) \\ &\times Z_{\text{int}}^{(Y)}(\{\boldsymbol{\sigma}^{\gamma'}\}, \eta, \{m_1, m_2, m_3, m_F^{(p_1)}, x_F^{(p_2-1)}\}), \end{aligned} \quad (4.124)$$

which manifestly reproduces the quiver gauge theory $Y^{(p_1, p_2-1)}$ in the third line of figure 29. The fundamental masses $m_{\text{fund } j}^{(3)}$ in the above expression are given as

$$m_{\text{fund } j}^{(3)} = -\sum_{k=1}^j \xi^{(k)} - b_{\mathcal{A}}\eta. \quad (4.125)$$

The Higgs branch global symmetry of the quiver $X_{\mathcal{P}}^{(p_1, p_2-1)}$ is $G_H^{X_{\mathcal{P}}^{(p_1, p_2-1)}} = \text{SU}(3) \times \text{U}(1)_{p_1} \times \text{U}(1)_{p_2-1}$, where (m_1, m_2, m_3) parametrize the Cartan subalgebra of the $\text{SU}(3)$, while the other masses $(m_F^{(p_1)}, x_F^{(p_2-1)})$ parametrize the Cartan of $\text{U}(1)_{p_1} \times \text{U}(1)_{p_2-1}$ respectively.

- Finally, let us implement the sequence of Abelian S -type operations \mathcal{O}''_k ($k = 1, 2, \dots, p_3$), where \mathcal{O}''_1 is an identification-flavoring-gauging operation with $N_F^{\alpha} = 1$, acting on the $\text{U}(1)_{p_1} \times \text{U}(1)_{p_2-1}$ flavor nodes of the quiver $X_{\mathcal{P}}^{(p_1, p_2-1)}$. The nodes are shown in red in the third line of figure 29. The subsequent operations \mathcal{O}''_k ($k = 2, \dots, p_3$) are $N_F^{\alpha} = 1$ flavoring-gauging operations acting on the new $\text{U}(1)$

flavor node generated in the previous step. Proceeding in the same way as the relevant parts of the computation for the dual quiver Family I, II and III, one can confirm that the dual operation $\tilde{\mathcal{O}}'_k$ amounts to adding a fundamental hypermultiplet to the gauge node labelled 4 in the quiver $Y_{\mathcal{P}}^{(p_1, p_2-1, k-1)}$. We therefore simply state the final answer for the theory $Y_{\mathcal{P}}^{(p_1, p_2-1, p_3)}$:

$$\begin{aligned}
 Z_{Y_{\mathcal{P}}^{(p_1, p_2-1, p_3)}} &= \int \prod_{\gamma'=1}^4 [d\sigma^{\gamma'}] \prod_{k=1}^{p_3} Z_{1\text{-loop}}^{\text{fund}}(\sigma^4, m_{\text{fund}k}^{(4)}) \prod_{j=1}^{p_2-1} Z_{1\text{-loop}}^{\text{fund}}(\sigma^3, m_{\text{fund}j}^{(3)}) \\
 &\quad \times \prod_{i=1}^{p_1} Z_{1\text{-loop}}^{\text{bif}}(\sigma^3, \sigma^4, m_{\text{bif}i}^{(34)}) Z_{\text{int}}^{(Y)}(\{\sigma^{\gamma'}\}, \eta, \{\mathbf{m}, y_F^{(p_3)}, y_F^{(p_3)} + \mu\}), \quad (4.126)
 \end{aligned}$$

which manifestly reproduces the quiver gauge theory $Y' = Y^{(p_1, p_2-1, p_3)}$ in the last row of figure 29, with $\mathbf{m} = (m_1, m_2, m_3)$ and the fundamental masses $m_{\text{fund}}^{(4)}$ are given as

$$m_{\text{fund}k}^{(4)} = - \sum_{l=1}^k \zeta^{(l)} - \sum_{j=1}^{p_2-1} \xi^{(j)} - \sum_{i=1}^{p_1} \tilde{\eta}^{(i)} - (b_{\mathcal{A}} + b_4)\eta. \quad (4.127)$$

After a shift in the integration variables, the mirror map can be read off from (4.126) above.

$$m_{\text{bif}i}^{(34)} = \sum_{k=1}^i \tilde{\eta}^{(k)} + b_4\eta, \quad (i = 1, \dots, p_1) \quad (4.128)$$

$$m_{\text{fund}j}^{(3)} = \begin{cases} - \sum_{k=1}^j \xi^{(k)} - (b_{\mathcal{A}} + 1)\eta, & \text{if } j = 1, \dots, p_2 - 1 \\ -\eta, & \text{if } j = p_2, \end{cases} \quad (4.129)$$

$$m_{\text{fund}k}^{(4)} = - \sum_{l=1}^k \zeta^{(l)} - \sum_{j=1}^{p_2-1} \xi^{(j)} - \sum_{i=1}^{p_1} \tilde{\eta}^{(i)} - (b_{\mathcal{A}} + b_4 + 1)\eta, \quad (k = 1, \dots, p_3) \quad (4.130)$$

$$\eta'_l = -(m_l - m_{l+1}), \quad (l = 1, 2), \quad (4.131)$$

$$\eta'_3 = -m_3 + \mu, \quad (4.132)$$

$$\eta'_4 = y_F^{(p_3)} - m_3, \quad (4.133)$$

with the additional constraint $m_1 + m_2 + m_3 = 0$. The mass parameters of Y' manifestly live in the Cartan subalgebra of the Higgs branch global symmetry $G_H^{Y'} = U(p_1) \times U(p_2) \times U(p_3)$, while the FI parameters live in the Cartan subalgebra of the Coulomb branch global symmetry $G_C^{Y'} = \text{SU}(3) \times \text{U}(1)^2$. The Coulomb branch global symmetry can be read off from the observation that Y' contains a balanced sub-quiver with two gauge nodes (labelled 1 and 2) which gives an $\text{SU}(3)$ factor, along with two unbalanced nodes which contribute a $\text{U}(1)$ factor each.

5 3d mirror pairs for class \mathcal{S} SCFTs on a circle

In this section, we comment on the fact that special cases of the 3d mirror pairs, constructed in section 4, are related to certain 4d $\mathcal{N} = 2$ SCFTs of class \mathcal{S} , which arise from the twisted

compactification of a 6d (2,0) A_{N-1} theory on a Riemann surface with punctures [39, 53, 54]. Putting a 4d class \mathcal{S} SCFT on a circle and flowing to the deep IR yields an interacting 3d SCFT which generically may not have a Lagrangian description. For theories with non-trivial Higgs branches, the class \mathcal{S} construction can be used to argue that the 3d mirror of the aforementioned SCFT has a Lagrangian description [30, 31, 37]. For the purpose of this paper, we will restrict ourselves to 4d SCFTs that arise from a 6d (2,0) A_{N-1} theory compactified on a Riemann sphere with either a single irregular puncture, or a single irregular puncture and a single regular puncture. The 4d SCFTs that arise from such compactification were classified in [31, 39, 55, 56]. A subset of these 4d theories were found to have a Lagrangian 3d mirror. This includes, for example, Argyres-Douglas (AD) theories of the types $(A_s, A_{(s+1)p-1})$ and $(A_s, D_{(s+1)p+2})$, for s and p being positive integers.¹⁸

Our strategy, will be to show that many of these 3d mirrors, obtained via the class \mathcal{S} construction of [31], have Lagrangian mirrors themselves, using our findings from section 4. This will allow us to propose explicit 3d $\mathcal{N} = 4$ Lagrangian descriptions for the 3d SCFTs that are constructed by taking the related 4d SCFTs on a circle and flowing to the deep IR. This shows that the 3d SCFTs have a pair of Lagrangian descriptions, which, in particular, implies that the Coulomb branch and the Higgs branch of the SCFT can both be described as hyperkähler quotients. Our construction, using S -type operations, can be extended to the 4d SCFTs (with 3d Lagrangian mirrors) arising from more general punctures. Most of these cases, however, necessitate the use of non-Abelian S -type operations and will be discussed in a future paper [41].

In section 5.1, we make some general comments about the 4d SCFTs of interest, which include the AD theories, and their 3d mirrors. In section 5.2, we discuss 3d mirror pairs associated with 4d SCFTs which arise from the compactification of the A_{N-1} 6d theory on a Riemann sphere with a single irregular puncture. This includes AD theories of the type $(A_s, A_{(s+1)p-1})$ for positive integers s, p , of which the 3d mirror pair for the $s = 1$ case was already known. We will explicitly write down the mirror pairs for $s \leq 3$, and generic p , but the generalization to higher values of s can be obtained in an analogous fashion. In section 5.3, we discuss 3d mirror pairs associated with 4d SCFTs which arise from the 6d A_{N-1} theory compactified on a Riemann sphere with a single irregular puncture and a single minimal regular puncture. This includes AD theories of the type $(A_s, D_{(s+1)p+2})$ positive integers s, p , of which the 3d mirror pairs for the $s = 1$ case was previously known. Again, we explicitly write down the mirror pairs for $s \leq 2$ and generic p , but the generalization to higher values s can be obtained in a similar fashion. We also discuss an SCFT which arises from a single irregular puncture and a single maximal regular puncture, and present the associated 3d mirror pair.

5.1 AD theories, (G, G') theories and Lagrangian 3d mirrors

AD SCFTs were originally discovered [64, 65] as the IR theories that arise at special points on the Coulomb branch of 4d $\mathcal{N} = 2$ $SU(N)$ SYM, where mutually non-local dyons became

¹⁸The reduction of AD theories on a circle has a large literature. For some of the recent work on this subject, see [57–63] and the references therein.

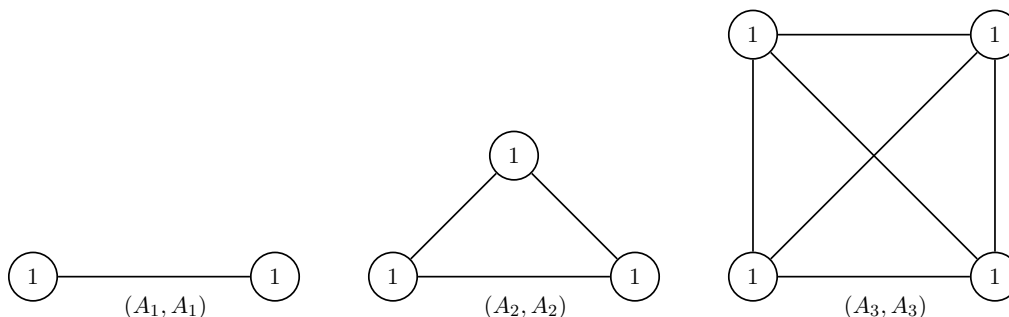

Figure 30. 3d mirrors from class \mathcal{S} construction for $(A_s, A_{(s+1)p-1})$ theories, with $s = 1, 2, 3$, and $p = 1$. For a given s , the 3d mirror for generic p is given by the same quiver diagram with every pair of gauge nodes being connected by p lines. The gauge group is obtained by factoring out an overall $U(1)$, which can be implemented by ungauging any one of the $U(1)$ gauge nodes.

massless. These strongly coupled SCFTs are characterized by fractional scaling dimensions of BPS operators on the Coulomb branch and the presence of relevant operators.

A large class of AD-type SCFTs were discovered in [40] using geometric engineering, where the authors studied the Type IIB superstring theory on a singular hypersurface of \mathbb{C}^4 given by the following locus:

$$W_G(x_1, x_2) + W_{G'}(y_1, y_2) = 0, \tag{5.1}$$

with G and G' being any pair of simply-laced groups, and $W_G, W_{G'}$ being quasi-homogeneous polynomials of the respective types. These SCFTs are therefore labelled by a pair of ADE singularities (G, G') .

It was soon understood that a much larger class of AD-type SCFTs, which includes the (G, G') SCFTs, can be realized in the class \mathcal{S} setting [53]. The construction, as discussed in [31, 39], involves compactifying a 6d A_{N-1} (2,0) theory on a Riemann sphere with an irregular puncture, i.e. singularity with a higher order pole in the Higgs field of the associated Hitchin system. The A -type irregular punctures and the associated SCFTs were classified in [31], and the construction was extended to other (2,0) theories in [55, 56]. Compactifying on a circle and flowing to the IR, an AD theory gives a 3d $\mathcal{N} = 4$ interacting SCFT, which is generically not expected to have a Lagrangian description. However, similar to the case for regular punctures [30], the class \mathcal{S} construction predicts a Lagrangian mirror dual for certain families of AD theories [31]. Two sub-families of the (G, G') SCFTs, namely the $(A_s, A_{(s+1)p-1})$ and $(A_s, D_{(s+1)p+2})$ SCFTs (for positive integers s and p), have 3d Lagrangian mirror duals and will feature prominently in our discussion.

First, consider the case of $(A_s, A_{(s+1)p-1})$ SCFTs. Generally speaking, the SCFTs of the type (A_{N-1}, A_{k-1}) are realized by compactifying on a Riemann sphere with a single irregular puncture of a specific type [31]. In the associated Hitchin system, the order of the pole of the Higgs field at the singular point is a linear function of the integer k . The 3d SCFT and its mirror generically do not have a known Lagrangian description. For the sub-family $(A_s, A_{(s+1)p-1})$, for which the Coulomb branch has a non-trivial global symmetry [66], one can expect a Lagrangian 3d mirror, and the precise form of the quivers

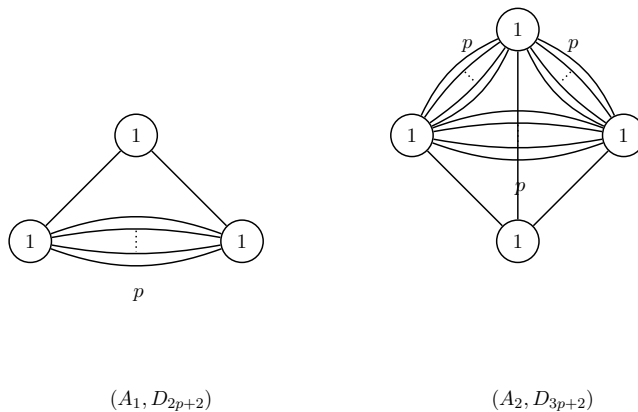

Figure 31. 3d mirrors from class \mathcal{S} construction for $(A_s, D_{(s+1)p+2})$ theories, with $s = 1, 2$, and generic p . The gauge group is obtained by factoring out an overall $U(1)$, which can be implemented by ungauging any one of the $U(1)$ gauge nodes.

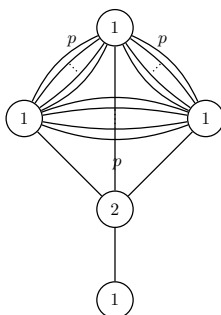

Figure 32. 3d mirror for a class \mathcal{S} SCFT which is obtained by compactifying the 6d A_2 theory on a Riemann sphere with an irregular puncture and a regular maximal puncture. The gauge group is obtained by factoring out an overall $U(1)$, which can be implemented by ungauging any one of the $U(1)$ gauge nodes.

can be guessed explicitly, as shown in figure 30. Similar to the case of the regular punctures, one can therefore associate a quiver tail to the associated irregular puncture.

Let us now consider the case of $(A_s, D_{(s+1)p+2})$ SCFTs. These are realized by compactifying the 6d A_s theory on a Riemann sphere with a single irregular puncture (the one associated with an $(A_s, A_{(s+1)p-1})$ theory) and a single minimal regular puncture. The 3d mirrors for this sub-family of SCFTs are also expected to have Lagrangian descriptions. The 3d mirrors are obtained by gluing the flavor nodes of the A_s minimal puncture quiver tail to the gauge nodes of the irregular puncture quiver tail [31, 67], as shown in figure 31.

In addition to the (G, G') theories, the class \mathcal{S} construction gives a rich class of AD theories, some of which can also have Lagrangian 3d mirrors. A particular class of such SCFTs can be realized by a compactification involving an irregular puncture of the $(A_s, A_{(s+1)p-1})$ type and a maximal A_s regular puncture. We will call this 4d SCFT $A_{s,p}^{\text{maximal}}$. The 3d mirror is obtained by gluing the flavor nodes of the A_s maximal puncture quiver tail to the gauge nodes of the irregular puncture quiver tail [31]. The 3d mirror for the case $s = 2$ and generic p is shown in figure 32.

Moduli space data	Theory X	Theory Y
$\dim \mathcal{M}_H$	$p - 1$	1
$\dim \mathcal{M}_C$	1	$p - 1$
G_H	$SU(p)$	$U(1)$
G_C	$U(1)$	$SU(p)$

Table 9. Summary table for the moduli space dimensions and global symmetries for the mirror pair in figure 33.

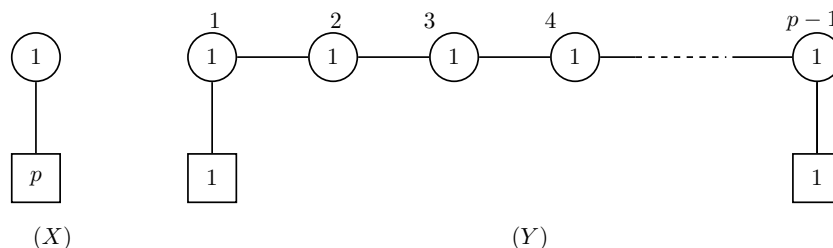

Figure 33. The pair of Lagrangian theories associated with the 3d $\mathcal{N} = 4$ SCFT that arise from the dimensional reduction of an (A_1, A_{2p-1}) AD theory on a circle.

5.2 Mirror pairs: 4d SCFTs from a single irregular puncture

5.2.1 Trivial case: (A_1, A_{2p-1}) theories for generic p

The mirror pair corresponding to the (A_1, A_{2p-1}) AD theories is well known. The class \mathcal{S} mirror, labelled as quiver X in figure 33, is a linear quiver which has a linear mirror dual given by quiver Y . The dimensions of the moduli spaces and global symmetries are summarized in table 9.

5.2.2 (A_2, A_{3p-1}) theories for generic p

The mirror pair in this case is given by figure 34. The class \mathcal{S} mirror is given by the quiver X , while the dual theory is given by the quiver Y . The duality can be read off from the dual pairs of Family I $_{[n,l,p]}$ in figure 17, labelled by the triplet of integers (n, l, p) , for the special case:

$$n = 2p, \quad l = p + 1, \quad p \geq 2. \quad (5.2)$$

The moduli space dimensions of the dual theories and the global symmetries associated with the Higgs and Coulomb branches are given in table 10.

5.2.3 (A_3, A_{4p-1}) theories with generic p

The dual pair in this case is given by figure 35. The class \mathcal{S} mirror is given by the quiver X , while the dual theory is given by the quiver Y . The duality can be read off from the dual pairs of Family II $_{[n,l,l_1,l_2,p_1,p_2]}$ in figure 20, labelled by the set of integers $(n, l, l_1, l_2, p_1, p_2)$,

Moduli space data	Theory X	Theory Y
$\dim \mathcal{M}_H$	$3p - 2$	2
$\dim \mathcal{M}_C$	2	$3p - 2$
G_H	$SU(p) \times SU(p) \times SU(p) \times U(1)$	$U(1) \times U(1)$
G_C	$U(1) \times U(1)$	$SU(p) \times SU(p) \times SU(p) \times U(1)$

Table 10. Summary table for the moduli space dimensions and global symmetries for the mirror pair in figure 34.

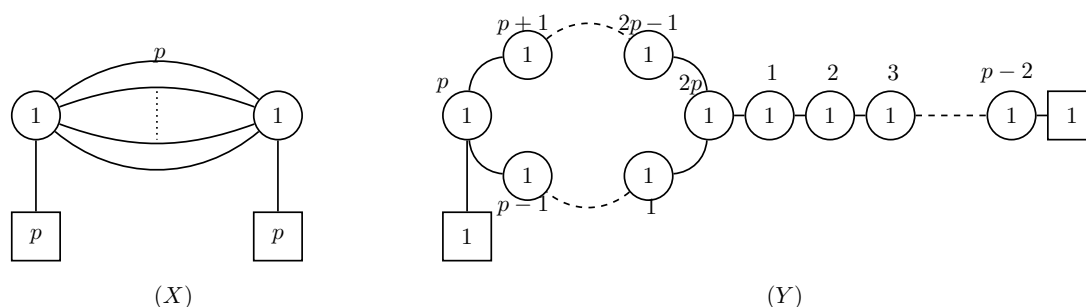

Figure 34. The pair of Lagrangian theories associated with the 3d $\mathcal{N} = 4$ SCFT that arise from the dimensional reduction of an $(A_s, A_{(s+1)p-1})$ AD theory on a circle, for $s = 2$ and generic p . Quiver (X) was obtained using class \mathcal{S} construction of AD theories, while quiver (Y) is the proposed 3d mirror dual of quiver (X) .

Moduli space data	Theory X	Theory Y
$\dim \mathcal{M}_H$	$6p - 3$	3
$\dim \mathcal{M}_C$	3	$6p - 3$
G_H	$SU(p)^3 \times SU(p)^3 \times U(1)^3$	$U(1)^3$
G_C	$U(1)^3$	$SU(p)^3 \times SU(p)^3 \times U(1)^3$

Table 11. Summary table for the moduli space dimensions and global symmetries for the mirror pair in figure 35.

for the special case:

$$n = 4p, \quad l = 2p, \quad l_1 = p, \quad l_2 = 3p, \quad (5.3)$$

$$p_1 = p_2 = p. \quad (5.4)$$

The moduli space dimensions of the dual theories and the global symmetries associated with the Higgs and Coulomb branches are given in table 11.

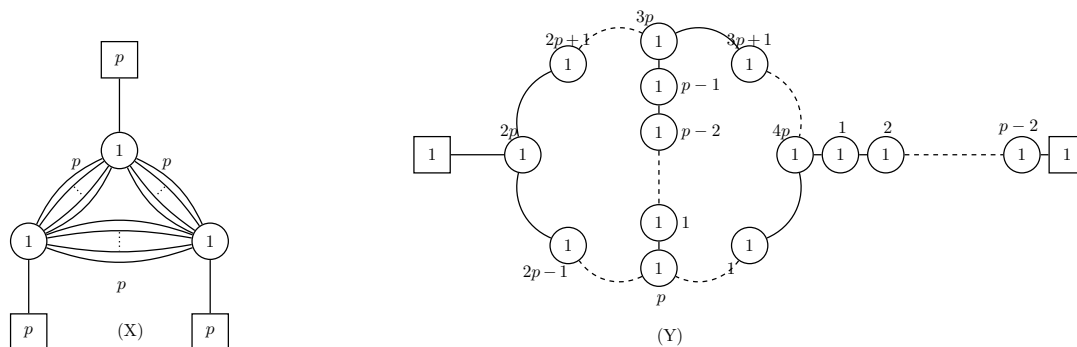

Figure 35. The pair of Lagrangian theories associated with the 3d $\mathcal{N} = 4$ SCFT that arise from the dimensional reduction of an $(A_s, A_{(s+1)p-1})$ AD theory on a circle, for $s = 3$ and generic p . Quiver (X) was obtained using class \mathcal{S} construction of AD theories, while quiver (Y) is the proposed 3d mirror dual of quiver (X).

Moduli space data	Theory X	Theory Y
$\dim \mathcal{M}_H$	p	2
$\dim \mathcal{M}_C$	2	p
G_H	$SU(p) \times U(1)$	$SU(2) \times U(1)$
G_C	$SU(2) \times U(1)$	$SU(p) \times U(1)$

Table 12. Summary table for the moduli space dimensions and global symmetries for the mirror pair in figure 36.

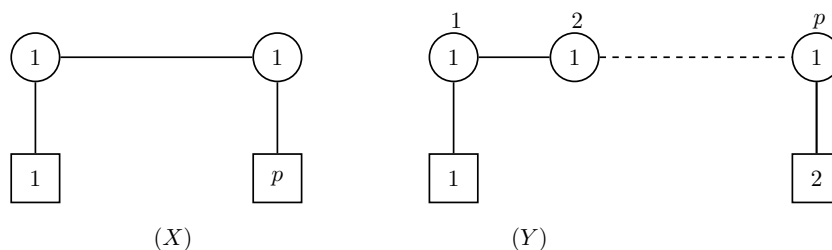

Figure 36. An example of a Lagrangian realization of the dimensional reduction of an (A_1, D_{2p+2}) theory is given by the quiver (Y) for generic p .

5.3 Mirror pairs: 4d SCFTs from a single irregular puncture and a regular puncture

5.3.1 Trivial case: (A_1, D_{2p+2}) theories for generic p

The mirror pair corresponding to the (A_1, D_{2p+2}) AD theories, like the (A_1, A_{2p-1}) case, is well known. The class \mathcal{S} mirror, labelled as quiver X in figure 36, is a linear quiver which has a linear mirror dual given by quiver Y. The dimensions of the moduli spaces and global symmetries are summarized in table 12.

Moduli space data	Theory X	Theory Y
$\dim \mathcal{M}_H$	$3p$	3
$\dim \mathcal{M}_C$	3	$3p$
G_H	$SU(p) \times SU(p) \times SU(p) \times U(1)^3$	$U(1)^3$
G_C	$U(1)^3$	$SU(p) \times SU(p) \times SU(p) \times U(1)^3$

Table 13. Summary table for the moduli space dimensions and global symmetries for the mirror pair in figure 37.

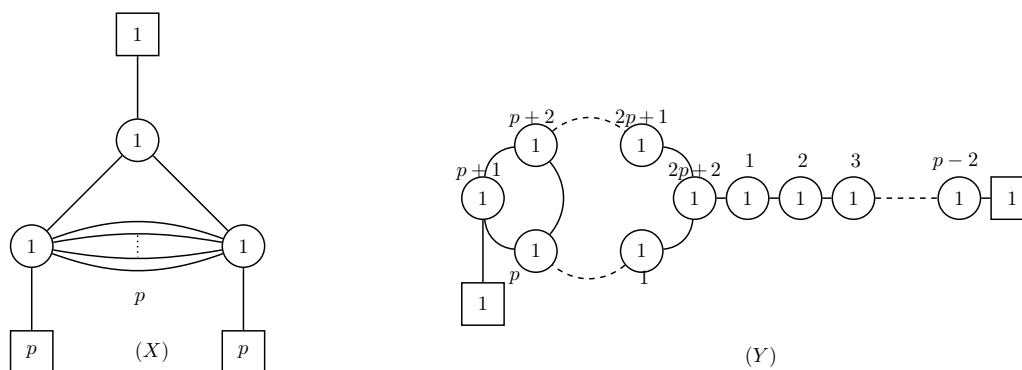

Figure 37. The pair of Lagrangian theories associated with the 3d $\mathcal{N} = 4$ SCFT that arise from the dimensional reduction of an $(A_s, D_{(s+1)p+2})$ AD theory on a circle, for $s = 2$ and generic p . Quiver (X) was obtained using class \mathcal{S} construction of AD theories, while quiver (Y) is the proposed 3d mirror dual of quiver (X) .

5.3.2 (A_2, D_{3p+2}) theories for generic p

The dual pair in this case is given by figure 37. The class \mathcal{S} mirror is given by the quiver X , while the dual theory is given by the quiver Y . The duality can be read off from the dual pairs of Family II $_{[n,l,l_1,l_2,p_1,p_2]}$ in figure 20, labelled by the set of integers $(n, l, l_1, l_2, p_1, p_2)$, for the special case:

$$n = 2p + 2, \quad l = p + 1, \quad l_1 = p, \quad l_2 = p + 2, \quad (5.5)$$

$$p_1 = p, \quad p_2 = 1. \quad (5.6)$$

The moduli space dimensions of the dual theories and the global symmetries associated with the Higgs and Coulomb branches are given in table 13.

5.3.3 4d SCFTs from an irregular puncture and a maximal puncture

We consider the specific case of the 4d SCFTs $A_{s,p}^{\text{maximal}}$, for $s = 2$ and generic p . As mentioned earlier, these SCFTs are realized from the twisted compactification of a $A_{s=2}$ $(2,0)$ 6d theory on a Riemann sphere with an irregular puncture (corresponding to the SCFT (A_2, A_{3p-1})) and a maximal regular puncture. The mirror pair in this case is given by figure 38. The class \mathcal{S} mirror is given by the quiver X , while the dual theory is given by the quiver Y . The duality can be read off from the dual pairs of Family IV $_{[p_1,p_2,p_3]}$ in

Moduli space data	Theory X	Theory Y
$\dim \mathcal{M}_H$	$3p + 1$	5
$\dim \mathcal{M}_C$	5	$3p + 1$
G_H	$SU(p) \times SU(p) \times SU(p) \times U(1)^3$	$SU(3) \times U(1)^2$
G_C	$SU(3) \times U(1)^2$	$SU(p) \times SU(p) \times SU(p) \times U(1)^3$

Table 14. Summary table for the moduli space dimensions and global symmetries for the mirror pair in figure 38.

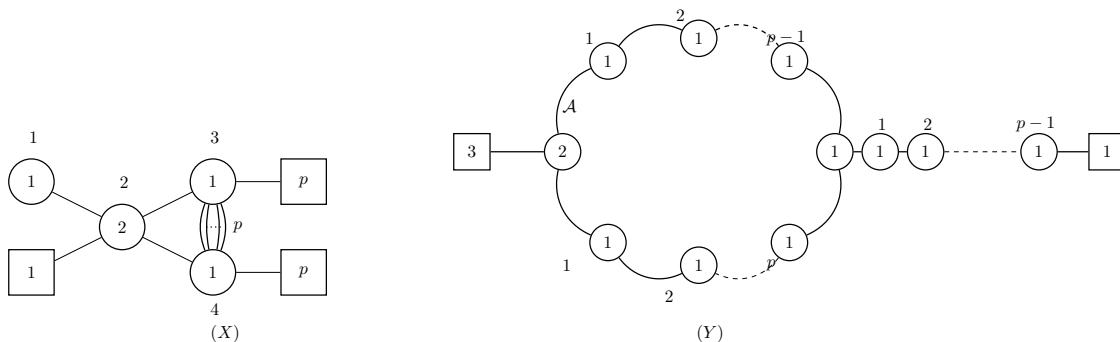

Figure 38. An example of a Lagrangian realization of the dimensional reduction of a 4d SCFT which is constructed in the class \mathcal{S} picture from an irregular puncture and a regular maximal puncture.

figure 26, labelled by the triplet of integers (p_1, p_2, p_3) , for the special case:

$$p_1 = p_2 = p_3 = p. \quad (5.7)$$

The moduli space dimensions of the dual theories and the global symmetries associated with the Higgs and Coulomb branches are given in table 14.

Acknowledgments

The author would like to thank Jacques Distler and Andrew Neitzke for various comments and discussion during the preparation of this work. The author would like to thank Vivek Saxena for comments on the draft and discussion on related issues. The author would also like to thank Ibrahima Bah, Aswin Balasubramanian, Amihay Hanany, Gregory Moore, Wolfer Peelaers, Martin Roček, and Jaewon Song for discussion at various stages of the project. The author is partially supported at the Johns Hopkins University by NSF grant PHY-1820784. A significant fraction of the work was done at the NHEHC, Rutgers, where the author's postdoctoral fellowship was supported by the DOE grant DOE-SC0010008.

A Flavoured D_4 quivers: dependence of the dual Lagrangian on \mathcal{P}

In this section, we work out two sets of simple examples of mirror dual theories, involving D-type quivers (and their affine cousins), which can be obtained from linear quivers using

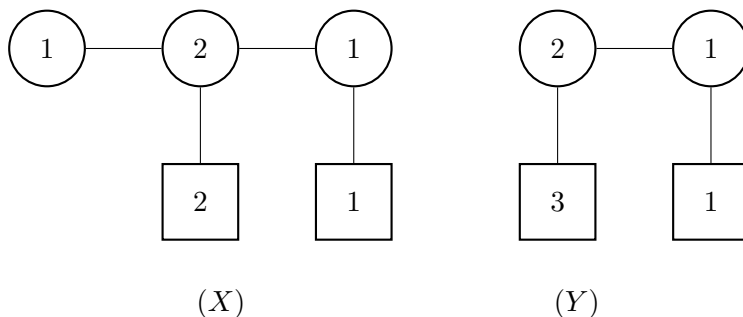

Figure 39. A pair of linear quiver theories mirror dual to each other.

Abelian S -type operations. The first set involves gauging operations, while the second involves flavoring-gauging operations. The resultant dual pairs have appeared in the literature of 3d mirror symmetry [18, 19, 23], and were studied from a Type IIB point of view in [25, 27]. We present them here to illustrate how the Abelian S -type operations work in simple examples involving non-Abelian gauge groups. In addition, we show that the mirror dual of a given theory can have multiple Lagrangian descriptions labelled by the data \mathcal{P} . As mentioned earlier, we turn off all defects and CS interactions for these examples.

Consider the pair of linear quiver gauge theories, X and Y , in figure 39, which are mirror dual to each other. The theory X has a Higgs branch global symmetry $G_H^X = (\text{U}(2) \times \text{U}(1))/\text{U}(1)$, where the Cartan subalgebras of $\text{U}(2)$ and $\text{U}(1)$ are parametrized by the mass parameters (m_1, m_2) and m_3 respectively. We choose to implement the $\text{U}(1)$ quotient by the constraint $m_3 = 0$, and therefore identify $G_H^X = \text{U}(2)$ and with the $\text{U}(2)$ flavor node of quiver X . We will implement the Abelian S -type operations at this $\text{U}(2)$ flavor node. The S^3 partition function of X is given as:

$$\begin{aligned}
 Z^{(X)}(\mathbf{m}, \mathbf{t}) &= \int \prod_{\gamma=1}^3 [d\mathbf{s}^\gamma] Z_{\text{int}}^{(X)}(\{\mathbf{s}^{\gamma'}\}, \mathbf{m}, \mathbf{t}) \\
 &= \int Z_{\text{FI}}^{(X)}(\{\mathbf{s}^\gamma\}, \mathbf{t}) Z_{1\text{-loop}}^{\text{vector}}(\mathbf{s}^2) \prod_{i=1}^2 Z_{1\text{-loop}}^{\text{fund}}(\mathbf{s}^2, \mathbf{m}_i) Z_{1\text{-loop}}^{\text{fund}}(\mathbf{s}^3, 0) \prod_{\gamma=1}^2 Z_{1\text{-loop}}^{\text{bif}}(\mathbf{s}^\gamma, \mathbf{s}^{\gamma+1}, 0),
 \end{aligned} \tag{A.1}$$

where $Z_{\text{FI}}^{(X)}$ and the one-loop factors are given in (2.28). Similarly, the partition function of the quiver Y is given as

$$\begin{aligned}
 Z^{(Y)}(\mathbf{t}, \mathbf{m}) &= \int \prod_{\gamma'=1}^2 [d\boldsymbol{\sigma}^{\gamma'}] Z_{\text{int}}^{(Y)}(\{\boldsymbol{\sigma}^\gamma\}, \mathbf{t}, \mathbf{m}) \\
 &= \int Z_{\text{FI}}^{(Y)}(\{\boldsymbol{\sigma}^{\gamma'}\}, \mathbf{m}) Z_{1\text{-loop}}^{\text{vector}}(\boldsymbol{\sigma}^1) \prod_{l=1}^3 Z_{1\text{-loop}}^{\text{fund}}(\boldsymbol{\sigma}^1, t_l) Z_{1\text{-loop}}^{\text{fund}}(\boldsymbol{\sigma}^2, t_4) Z_{1\text{-loop}}^{\text{bif}}(\boldsymbol{\sigma}^1, \boldsymbol{\sigma}^2, 0),
 \end{aligned} \tag{A.2}$$

where $Z_{\text{FI}}^{(Y)}$ and the one-loop factors are given in (2.30). In particular, $Z_{\text{FI}}^{(Y)}$ can be explicitly written as

$$Z_{\text{FI}}^{(Y)}(\{\boldsymbol{\sigma}^{\gamma'}\}, \mathbf{m}) = e^{2\pi i(m_1 - m_2)\text{Tr}\boldsymbol{\sigma}^1} e^{2\pi i m_2 \sigma^2}. \tag{A.3}$$

Mirror symmetry implies that the two partition functions are related in the following fashion:

$$Z^{(X)}(\mathbf{m}, \mathbf{t}) = e^{2\pi i(m_1(t_1+t_2)-m_2t_3)} Z^{(Y)}(-\mathbf{t}, \mathbf{m}). \tag{A.4}$$

A.1 Abelian gauging operations

Let us implement an Abelian Gauging operation at the U(2) flavor node of theory (X, \mathcal{P}) , which we label as α . The theory $X' = G_{\mathcal{P}}^{\alpha}(X)$ is given by figure 40, and is independent of the permutation matrix \mathcal{P} . The Lagrangian of the dual theory, however, depends on the choice of the matrix \mathcal{P} , and we will derive the dual Lagrangians explicitly for the two possible choices of \mathcal{P} . Consider first the choice $\mathcal{P} = \mathcal{P}_1 = \mathbb{I}_{2 \times 2}$, for which, following (3.1), we define

$$u^{\alpha} = m_1, \quad v^{\alpha} = m_2. \tag{A.5}$$

The mirror symmetry relation (A.4) then implies that

$$Z^{(X, \mathcal{P}_1)}(u^{\alpha}, v^{\alpha}, \mathbf{t}) = e^{2\pi i(u^{\alpha}(t_1+t_2)-v^{\alpha}t_3)} Z^{(Y, \mathcal{P}_1)}(-\mathbf{t}, u^{\alpha}, v^{\alpha}), \tag{A.6}$$

and the FI contribution to the partition function of the theory (Y, \mathcal{P}_1) in (A.3) can be written as

$$Z_{\text{FI}}^{(Y, \mathcal{P}_1)}(\{\boldsymbol{\sigma}^{\gamma'}\}, u^{\alpha}, v^{\alpha}) = e^{2\pi i u^{\alpha} \text{Tr} \boldsymbol{\sigma}^1} e^{2\pi i v^{\alpha} (\sigma^2 - \text{Tr} \boldsymbol{\sigma}^1)}. \tag{A.7}$$

From the general formula (4.7) for the dual of Abelian gauging, we then have

$$Z^{\tilde{G}_{\mathcal{P}_1}(Y)}(\mathbf{m}'(\mathbf{t}, \eta_{\alpha}); \eta'(v^{\alpha})) = \int \prod_{\gamma'=1}^2 [d\boldsymbol{\sigma}^{\gamma'}] \delta(\eta_{\alpha} + b^l t_l + \text{Tr} \boldsymbol{\sigma}^1) \cdot Z_{\text{int}}^{(Y, \mathcal{P}_1)}(\{\boldsymbol{\sigma}^{\gamma'}\}, -\mathbf{t}, u^{\alpha} = 0, v^{\alpha}), \tag{A.8}$$

where $b^l = 1, l = 1, 2$. Shifting the integration variables, one can recast the above integral (up to some phase factors) as:

$$\begin{aligned} Z^{\tilde{G}_{\mathcal{P}_1}(Y)}(\mathbf{m}'(\mathbf{t}, \eta_{\alpha}); \eta'(v^{\alpha})) &= \int \prod_{\gamma'=1}^2 [d\boldsymbol{\sigma}^{\gamma'}] \delta(\text{Tr} \boldsymbol{\sigma}^1) Z_{\text{FI}}(\sigma^2, v^{\alpha}) Z_{1\text{-loop}}^{\text{vector}}(\boldsymbol{\sigma}^1) \\ &\quad \times \prod_{l=1}^3 Z_{1\text{-loop}}^{\text{fund}}(\boldsymbol{\sigma}^1, -t_l + \delta) Z_{1\text{-loop}}^{\text{fund}}(\sigma^2, -t_4 + \delta) Z_{1\text{-loop}}^{\text{bif}}(\boldsymbol{\sigma}^1, \sigma^2, 0) \\ &= \int \prod_{\gamma'=1}^2 [d\boldsymbol{\sigma}^{\gamma'}] Z_{\text{int}}^{(Y')}(\{\boldsymbol{\sigma}^{\gamma'}\}, \mathbf{m}' = -\mathbf{t} + \delta, \eta' = v^{\alpha}) \\ &= Z^{(Y')}(\mathbf{m}' = -\mathbf{t} + \delta, \eta' = v^{\alpha}), \end{aligned} \tag{A.9}$$

where $\delta = \frac{\eta_{\alpha} + b^l t_l}{2}$, and the theory (Y') is the quiver in figure 41. The map of mass and FI parameters between the pair of dual theories (X', Y') can be read off from the final equality.

Now, consider the other possible choice of $\mathcal{P} = \mathcal{P}_2 = \begin{pmatrix} 0 & 1 \\ 1 & 0 \end{pmatrix}$, such that (3.1)

$$v^{\alpha} = m_1, \quad u^{\alpha} = m_2. \tag{A.10}$$

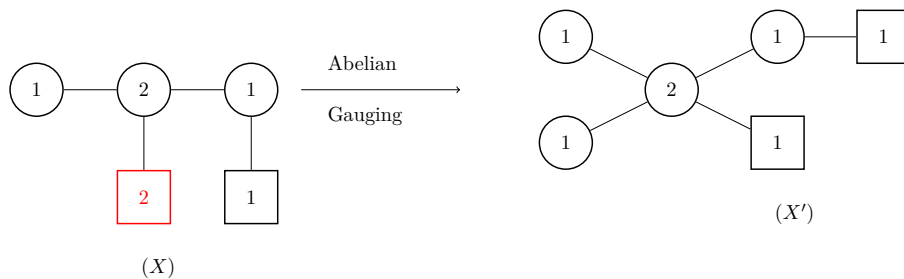

Figure 40. A U(1) gauging operation on the quiver X leading to the theory X' .

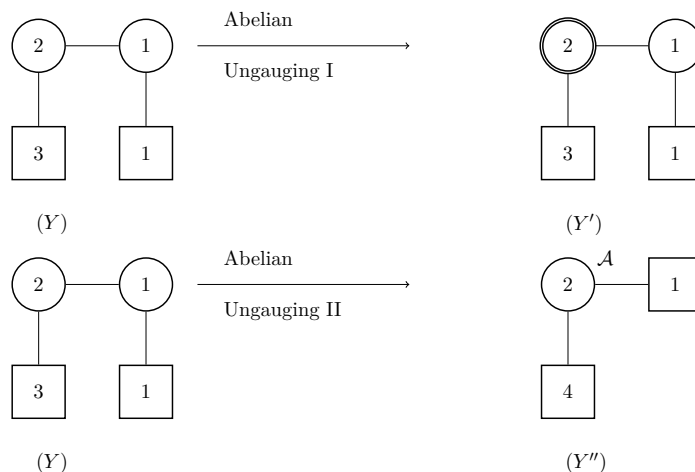

Figure 41. The figure shows the two quiver gauge theories — Y' and Y'' — that arise from the Abelian ungauging operation on the theory (Y) for two different choices of \mathcal{P} . The line labelled as \mathcal{A} denotes a hypermultiplet in the rank-2 antisymmetric representation of the gauge group U(2) and has charge 1 under the flavor symmetry group U(1). It is charge 2 under the U(1) subgroup of U(2), and uncharged under the SU(2).

The mirror symmetry relation (A.4) then implies that

$$Z^{(X, \mathcal{P}_2)}(u^\alpha, v^\alpha, \mathbf{t}) = e^{2\pi i(v^\alpha(t_1+t_2)-u^\alpha t_3)} Z^{(Y, \mathcal{P}_2)}(-\mathbf{t}, u^\alpha, v^\alpha), \tag{A.11}$$

and the FI contribution to the partition function of the theory (Y, \mathcal{P}_2) in (A.3) can be written as

$$Z_{\text{FI}}^{(Y, \mathcal{P}_2)}(\{\sigma^{\gamma'}\}, u^\alpha, v^\alpha) = e^{2\pi i v^\alpha \text{Tr} \sigma^1} e^{2\pi i u^\alpha (\sigma^2 - \text{Tr} \sigma^1)}. \tag{A.12}$$

Using (4.7) and following the same steps as above, we can show that (up to some phase factors)

$$\begin{aligned}
 Z^{\tilde{G}_{P_2}(Y)}(\mathbf{m}'(\mathbf{t}, \eta_\alpha); \eta'(v^\alpha)) &= \int \frac{d\sigma^1}{2!} Z_{\text{FI}}(\sigma^1, v^\alpha) Z_{1\text{-loop}}^{\text{vector}}(\sigma^1) \\
 &\quad \times \prod_{l=1}^4 Z_{1\text{-loop}}^{\text{fund}}(\sigma^1, m'_l(\mathbf{t}, \eta_\alpha)) Z_{1\text{-loop}}^{\text{A}}(\sigma^1, -t_4) \\
 &= \int \frac{d^2\sigma^1}{2!} Z_{\text{int}}^{(Y'')}(\sigma^1, \mathbf{m}'(\mathbf{t}, \eta_\alpha), \eta' = v^\alpha) \\
 &= Z^{(Y'')}(\mathbf{m}'(\mathbf{t}, \eta_\alpha), \eta' = v^\alpha), \tag{A.13}
 \end{aligned}$$

where $Z_{1\text{-loop}}^{\text{A}}$ denotes the 1-loop contribution of a hypermultiplet in a rank-1 antisymmetric representation of $U(2)$, and Y'' is the quiver shown in the second row of figure 41. Note that $Z_{1\text{-loop}}^{\text{A}}(\sigma^1, -t_4) = Z_{1\text{-loop}}^{\text{fund}}(\text{Tr}\sigma^1, -t_4)$. The mass parameters of Y'' are given as

$$m'_l = -t_l - \delta_0, \text{ for } l = 1, 2, 3, \tag{A.14}$$

$$m'_4 = \eta_\alpha - t_3 - \delta_0, \tag{A.15}$$

$$m'_{\mathcal{A}} = \eta_\alpha - t_3 - t_4 - 2\delta_0, \tag{A.16}$$

where δ_0 should be chosen depending on the constraint one imposes on the masses Y'' — $\sum_{l=1}^4 m'_l = 0$, or $m'_{\mathcal{A}} = 0$. The FI parameter of Y'' is

$$\eta' = v^\alpha = m_1. \tag{A.17}$$

We conjecture that the two theories Y' and Y'' are different Lagrangians of the theory mirror dual to X' . The global symmetries (Higgs and Coulomb) of Y' and Y'' match (up to a discrete group):

$$\begin{aligned}
 G_H^{Y'} &= \text{SO}(6) \times \text{U}(1), & G_C^{Y'} &= \text{U}(1), \\
 G_H^{(Y'')} &= \text{SU}(4) \times \text{U}(1), & G_C^{(Y'')} &= \text{U}(1). \tag{A.18}
 \end{aligned}$$

Note that the Higgs branch symmetry associated with n fundamental hypers (i.e. $2n$ fundamental half-hypers) in Y' is $\text{SO}(2n)$. Also, note that the Coulomb branch symmetry of (Y'') is not enhanced because of the additional antisymmetric hyper.

Finally, consider a sequence of two Abelian gauging operations on the quiver X , such that the $U(1) \times U(1)$ subgroup of the $U(2)$ flavor symmetry of quiver X is gauged. We will denote these S -type operations as G_1 and G_2 respectively. The resultant quiver $X' = G_2 \circ G_1(X)$ is an affine D_4 quiver with a single flavor, shown in figure 42. In this case, the dual theory is independent of the permutation matrix \mathcal{P} and therefore one can drop the explicit \mathcal{P} -dependence from the partition functions. Let us define:

$$u^1 = m_1, \quad u^2 = m_2. \tag{A.19}$$

The mirror symmetry relation (A.4) then implies that

$$Z^{(X)}(u^1, u^2, \mathbf{t}) = e^{2\pi i(u^1(t_1+t_2) - u^2 t_3)} Z^{(Y)}(-\mathbf{t}, u^1, u^2), \tag{A.20}$$

and the FI contribution to the partition function of the theory (Y, \mathcal{P}_1) in (A.3) can be written as

$$Z_{\text{FI}}^{(Y)}(\{\boldsymbol{\sigma}^{\gamma'}\}, u^1, u^2) = e^{2\pi i u^1 \text{Tr} \boldsymbol{\sigma}^1} e^{2\pi i u^2 (\sigma^2 - \text{Tr} \boldsymbol{\sigma}^1)}. \quad (\text{A.21})$$

Using the general formula (4.7) for the dual of Abelian gauging twice, we have

$$\begin{aligned} Z^{\tilde{G}_2 \circ \tilde{G}_1(Y)}(\mathbf{m}'(\mathbf{t}, \boldsymbol{\eta}); \eta'(v)) &= \int \prod_{\gamma'=1}^2 [d\boldsymbol{\sigma}^{\gamma'}] \delta(\eta_1 + b^{1l} t_l + \text{Tr} \boldsymbol{\sigma}^1) \cdot \delta(\eta_2 + b^{2l} t_l - \text{Tr} \boldsymbol{\sigma}^1 + \sigma^2) \\ &\times Z_{\text{int}}^{(Y)}(\{\boldsymbol{\sigma}^{\gamma'}\}, -\mathbf{t}, u_i = 0), \end{aligned} \quad (\text{A.22})$$

where $b^{1l} = 1$, $l = 1, 2$ and $b^{23} = -1$ are the non-vanishing components of the matrix b^{il} . Shifting the integration variables, one can recast the above integral (up to some phase factors) as:

$$\begin{aligned} Z^{\tilde{G}_2 \circ \tilde{G}_1(Y)}(\mathbf{m}'(\mathbf{t}, \boldsymbol{\eta}); \eta'(v)) &= \int \frac{d^2 \sigma^1}{2!} \delta(\text{Tr} \boldsymbol{\sigma}^1) Z_{1\text{-loop}}^{\text{vector}}(\boldsymbol{\sigma}^1) \\ &\times \prod_{l=1}^4 Z_{1\text{-loop}}^{\text{fund}}(\boldsymbol{\sigma}^1, m_l(\mathbf{t}, \boldsymbol{\eta})) Z^{\text{free}}(t_4 - 2(\delta + \delta')) \\ &= \int \frac{d^2 \sigma^1}{2!} Z_{\text{int}}^{(Y')}(\boldsymbol{\sigma}^1, \mathbf{m}'(\mathbf{t}, \boldsymbol{\eta})) \\ &= Z^{(Y')}(\mathbf{m}'(\mathbf{t}, \boldsymbol{\eta})), \end{aligned} \quad (\text{A.23})$$

where the theory (Y') is the quiver in figure 42, and the mass parameters $m_l = -t_l + \delta$ for $l = 1, 2, 3$, $m_4 = 2\delta'$, with $\delta = \frac{\eta_1 + b^{1l} t_l}{2}$ and $\delta' = \frac{\eta_2 + b^{2l} t_l}{2}$. The partition function of a free hypermultiplet of mass m is $Z^{\text{free}}(m) = \frac{1}{\cosh \pi m}$. The map of mass and FI parameters between the pair of dual theories (X', Y') can be read off from the final equality.

A.2 Abelian flavoring-gauging operation

Consider an Abelian S -type operation on the quiver X involving an Abelian flavoring-gauging at the $U(2)$ flavor node, followed by an Abelian gauging operation at the remaining $U(1)$ flavor node. Splitting the $U(2)$ flavor node as $U(2) \rightarrow U(1)_1 \times U(1)_2$, the S -type operation can be written as $\mathcal{O}_{\mathcal{P}} = G^2 \circ (G_{\mathcal{P}}^1 \circ F_{\mathcal{P}}^1)$. The quiver $X' = G^2 \circ (G_{\mathcal{P}}^1 \circ F_{\mathcal{P}}^1)(X)$ is shown in figure 43. The resultant quiver X' is an affine D_4 quiver with a single flavor. Choosing the permutation matrix \mathcal{P} as $\mathcal{P} = \mathcal{P}_1 = \mathbb{I}_{2 \times 2}$, we define

$$u^1 = m_1, \quad u^2 = m_2, \quad (\text{A.24})$$

where the operation $(G_{\mathcal{P}}^1 \circ F_{\mathcal{P}}^1)$ gauges the $U(1)_1$ flavor node, and G^2 gauges $U(1)_2$.

The mirror symmetry relation (A.4) can be written as

$$Z^{(X)}(u^1, u^2, \mathbf{t}) = e^{2\pi i (u^1(t_1+t_2) - u^2 t_3)} Z^{(Y)}(-\mathbf{t}, u^1, u^2), \quad (\text{A.25})$$

and the FI term in the partition function of the theory (Y, \mathcal{P}_1) in (A.3) can be written as

$$Z_{\text{FI}}^{(Y)}(\{\boldsymbol{\sigma}^{\gamma'}\}, u^1, u^2) = e^{2\pi i u^1 \text{Tr} \boldsymbol{\sigma}^1} e^{2\pi i u^2 (\sigma^2 - \text{Tr} \boldsymbol{\sigma}^1)}. \quad (\text{A.26})$$

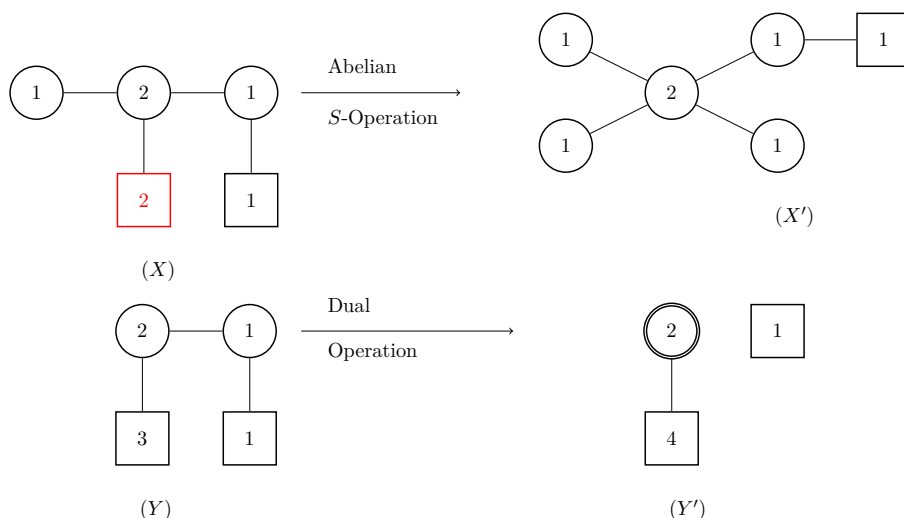

Figure 42. This figure shows the action of an Abelian S -type operation (involving two elementary gauging operations) on the quiver X and the dual operation the quiver Y of figure 39 respectively. The quiver X' is mirror dual to the quiver Y' .

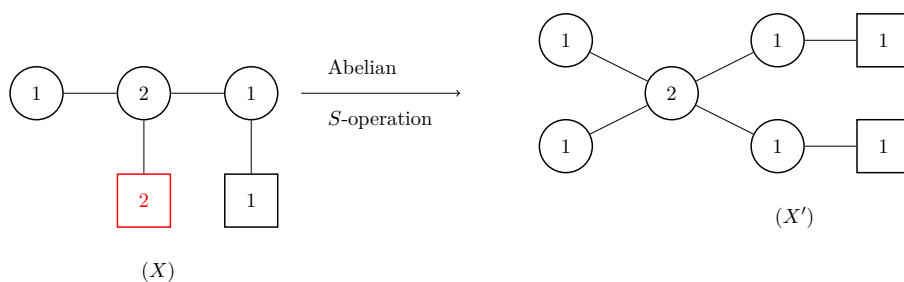

Figure 43. This figure shows the action of an Abelian S -type operation (involving an elementary flavoring-gauging and an elementary gauging operation) on the quiver X on the l.h.s.

The operation $\mathcal{O}_{\mathcal{P}_1}(X)$ gives the quiver on the r.h.s. in figure 43. The partition function of the dual theory $\tilde{\mathcal{O}}_{\mathcal{P}_1}(Y)$ can be obtained by first using the general formula (4.19)–(4.20) and then the formula (4.7), which gives:

$$\begin{aligned}
 Z^{\tilde{\mathcal{O}}_{\mathcal{P}_1}(Y)}(\mathbf{m}'(\mathbf{t}, \boldsymbol{\eta}), \eta'(m_F^\alpha)) &= \int \prod_{\gamma'=1}^2 [d\sigma^{\gamma'}] \frac{\delta(\eta_2 + b^{2l}t_l - \text{Tr}\boldsymbol{\sigma}^1 + \sigma^2)}{\cosh \pi(\text{Tr}\boldsymbol{\sigma}^1 + \eta_1 + b^{1l}t_l)} \\
 &\times Z_{\text{int}}^{(Y, \mathcal{P}_1)}(\{\boldsymbol{\sigma}^{\gamma'}\}, -\mathbf{t}, u^1 = m_F^\alpha, u^2 = 0), \quad (\text{A.27})
 \end{aligned}$$

where $b^{1l} = 1, l = 1, 2$ and $b^{23} = -1$ are the non-vanishing components of the matrix b^{il} . Imposing the delta function and shifting the integration variables by constants, one can

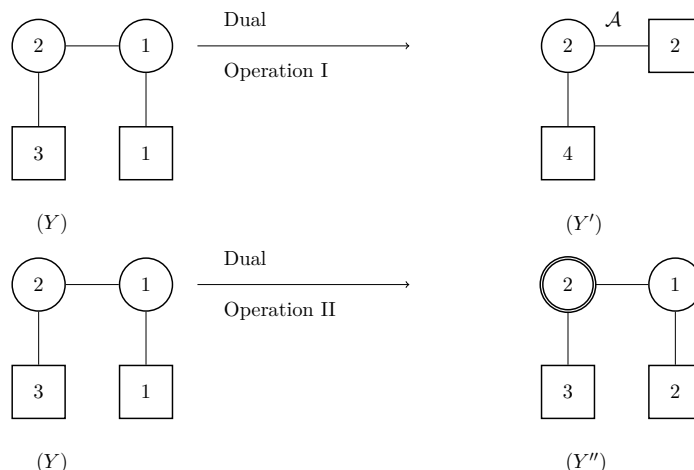

Figure 44. This figure shows dual operations for different choices of the permutation matrix \mathcal{P} . The quiver (X') in figure 43 is mirror dual to the quivers (Y') and (Y'') . The quiver (Y') has a pair of hypermultiplets in the rank-2 antisymmetric representation of the gauge group $U(2)$. Note that the theories (Y') and (Y'') have the same Coulomb and Higgs branch symmetries.

recast the above integral (up to some phase factors) as:

$$\begin{aligned}
 Z^{\tilde{\mathcal{O}}_{\mathcal{P}_1}(Y)} &= \int \frac{d^2\sigma^1}{2!} Z_{\text{FI}}(\sigma^1, m_F^\alpha) Z_{1\text{-loop}}^{\text{vector}}(\sigma^1) \\
 &\quad \times \prod_{l=1}^4 Z_{1\text{-loop}}^{\text{fund}}(\sigma^1, m'_l(\mathbf{t}, \boldsymbol{\eta})) \prod_{k=1}^2 Z_{1\text{-loop}}^{\mathcal{A}}(\sigma^1, m_{\mathcal{A}}^k(\mathbf{t}, \boldsymbol{\eta})) \quad (\text{A.28})
 \end{aligned}$$

$$= Z^{(Y')}(\mathbf{m}'(\mathbf{t}, \boldsymbol{\eta}), \mathbf{m}'_{\mathcal{A}}(\mathbf{t}, \boldsymbol{\eta}), \eta' = m_F^\alpha), \quad (\text{A.29})$$

where the theory Y' is the quiver in figure 44, and \mathbf{m}' , $\mathbf{m}'_{\mathcal{A}}$ denote the masses for the four fundamental hypers and the two rank-2 antisymmetric hypers of the $U(2)$ gauge group respectively. Explicitly, the mirror map is given as

$$m'_l(\mathbf{t}, \boldsymbol{\eta}) = -t_l + t_4/4 - (\delta' - \delta)/2, \quad \text{for } l = 1, 2, 3, \quad (\text{A.30})$$

$$m'_4(\mathbf{t}, \boldsymbol{\eta}) = t_4/4 - (\delta' - \delta)/2 + 2\delta', \quad (\text{A.31})$$

$$m_{\mathcal{A}}^1 = -m_{\mathcal{A}}^2 = -t_4/2 + (\delta' + \delta), \quad (\text{A.32})$$

$$\eta' = m_F^\alpha. \quad (\text{A.33})$$

where $\delta = \frac{\eta_1 + b^{1l}t_l}{2}$ and $\delta' = \frac{\eta_2 + b^{2l}t_l}{2}$. The masses, written above, parametrize the Cartan subalgebra of the Higgs branch global symmetry $G_H^{Y'} = U(4) \times SU(2)$, while the FI parameter parametrizes the Cartan of the Coulomb branch global symmetry $G_C^{Y'} = U(1)$.

One can proceed with the choice of the matrix $\mathcal{P} = \mathcal{P}_2 = \begin{pmatrix} 0 & 1 \\ 1 & 0 \end{pmatrix}$ in an analogous fashion, and show that the dual theory is given by the quiver (Y'') in figure 44, i.e.

$$Z^{\tilde{\mathcal{O}}_{\mathcal{P}_2}(Y)}(\mathbf{m}'(\mathbf{t}, \boldsymbol{\eta}), \eta'(m_F^\alpha)) = Z^{(Y'')}(\mathbf{m}'(\mathbf{t}, \boldsymbol{\eta}), \eta' = m_F^\alpha). \quad (\text{A.34})$$

Y' and Y'' are conjectured to be mirror dual to X' . The global symmetries of Y' and Y'' match, up to a discrete group:

$$\begin{aligned} G_H^{Y'} &= \text{SU}(4) \times \text{U}(2), & G_C^{Y'} &= \text{U}(1), \\ G_H^{(Y'')} &= \text{SO}(6) \times \text{U}(2), & G_C^{(Y'')} &= \text{U}(1). \end{aligned} \quad (\text{A.35})$$

B Superconformal index on $S^2 \times S^1$

B.1 Definition and localization formula

The 3d $\mathcal{N} = 4$ index on the manifold $S^2 \times S^1$ [34–36, 68] can be defined as:

$$\mathcal{I}_{S^2 \times S^1} = \text{Tr}_{S^2} \left[(-1)^F (\tilde{q})^{j_2 + \frac{R_H + R_C}{2}} (\tilde{t})^{R_H - R_C} e^{-\beta(E - 2j_2 - 2R_H - R_C)} \prod_i \mu_i^{f_i} \right], \quad (\text{B.1})$$

where j_2 is an angular momentum operator on S^2 , R_H and R_C are Cartan generators of the $su(2)_H$ and $su(2)_C$ Lie algebras respectively, and f_i collectively denote generators associated with other global symmetries. The index receives non-zero contributions from those states which satisfy $E - 2j_2 - 2R_H - R_C = 0$. Therefore, the 3d conformal dimension $\tilde{E} = \frac{E + R_C}{2}$ for the states contributing to the index can be written as

$$\tilde{E} = j_2 + R_H + R_C. \quad (\text{B.2})$$

Let us define the following parameters (x, \tilde{x}) in terms of (\tilde{q}, \tilde{t}) as follows:

$$x = \tilde{q}^{1/2} \tilde{t}, \quad \tilde{x} = \tilde{q}^{1/2} \tilde{t}^{-1}. \quad (\text{B.3})$$

Then the 3d index can be written as

$$\begin{aligned} \mathcal{I}_{S^2 \times S^1}(x, \tilde{x}; \mu_i) &= \text{Tr}_{S^2} \left[(-1)^F (x)^{\tilde{E} - R_C} (\tilde{x})^{\tilde{E} - R_H} e^{-\beta(\tilde{E} - j_2 - R_H - R_C)} \prod_i \mu_i^{f_i} \right], \\ &= \text{Tr}_{S^2} \left[(-1)^F (x)^{j_2 + R_H} (\tilde{x})^{j_2 + R_C} e^{-\beta(\tilde{E} - j_2 - R_H - R_C)} \prod_i \mu_i^{f_i} \right]. \end{aligned} \quad (\text{B.4})$$

Two important limits of the 3d index — the Coulomb branch index \mathcal{I}_C and the Higgs branch index \mathcal{I}_H — are defined as follows:

$$\begin{aligned} \mathcal{I}_C(\tilde{x}; \mu_i) &= \text{Tr}_{\mathcal{H}_C} \left[(-1)^F (\tilde{x})^{\tilde{E} - R_H} e^{-\beta(\tilde{E} - j_2 - R_H - R_C)} \prod_i \mu_i^{f_i} \right] = \lim_{x \rightarrow 0} \mathcal{I}_{S^2 \times S^1}(x, \tilde{x}; \mu_i) \\ \mathcal{I}_H(x; \mu_i) &= \text{Tr}_{\mathcal{H}_H} \left[(-1)^F (x)^{\tilde{E} - R_C} e^{-\beta(\tilde{E} - j_2 - R_H - R_C)} \prod_i \mu_i^{f_i} \right] = \lim_{\tilde{x} \rightarrow 0} \mathcal{I}_{S^2 \times S^1}(x, \tilde{x}; \mu_i). \end{aligned} \quad (\text{B.5})$$

Note that \mathcal{H}_C and \mathcal{H}_H are subspaces of the Hilbert space, where the states satisfy the constraints $\tilde{E} - R_C = 0$ and $\tilde{E} - R_H = 0$ respectively. It is sensible to take these limits of the original index since unitarity dictates that

$$\tilde{E} \geq R_{C,H}. \quad (\text{B.6})$$

Let us now write down the general expression of the index on $S^2 \times S^1$ for an $\mathcal{N} = 4$ gauge theory with gauge group G and global symmetry group G_H , where the hypermultiplets transforms in some representation \mathcal{R} of $G \times G_H$. This can be computed using localization and we refer the reader to the references [34, 35, 69, 70] for details of the computation, while simply providing the answer here. Let $\mathbf{z} \in T_G$, where T_G is the maximal torus of the group G , and let \mathbf{a} be the flux associated with G . Similarly, $(\tilde{\mathbf{z}}, \tilde{\mathbf{a}})$ denote the analogous pair for the global symmetry group G_H . We choose \mathbf{a} and $\tilde{\mathbf{a}}$ to take integer values. Also, let $\mathbf{s} \in \mathfrak{g}$, and $\mathbf{m} \in \mathfrak{g}_H$, where $\mathfrak{g}, \mathfrak{g}_H$ denote the Cartan subalgebra of \mathfrak{g} and \mathfrak{g}_H respectively, such that $\mathbf{z} = e^{2\pi i \mathbf{s}}$ and $\tilde{\mathbf{z}} = e^{2\pi i \mathbf{m}}$. In addition, we will turn on fugacities and discrete fluxes associated with the $U(1)_J$ symmetry of the theory. Let β label the unitary factors in the gauge group G , with $(\mathbf{z}^{(\beta)}, \mathbf{a}^{(\beta)})$ representing the fugacity and flux of the β -th unitary factor, and (w_β, n_β) denoting the fugacity and flux of a twisted $U(1)$ vector multiplet that couples to the $U(1)_J$ current of the β -th unitary factor.

Given the above data, the expression for the index can be written as a contour integral over \mathbf{z} summed over the fluxes \mathbf{a} , and the answer is a function of the global symmetry fugacities and fluxes, i.e. $(\tilde{\mathbf{z}}, \tilde{\mathbf{a}}, \mathbf{w}, \mathbf{n})$, in addition to the parameters \tilde{q}, \tilde{t} .

$$\begin{aligned} \mathcal{I}(\tilde{\mathbf{z}}, \tilde{\mathbf{a}}, \mathbf{w}, \mathbf{n}; \tilde{q}, \tilde{t}) &= \sum_{\{\mathbf{a}\}} \frac{1}{W(\mathbf{a})} \oint_{|z_i|=1} \prod_{i=1}^{\text{rank}G} \frac{dz_i}{2\pi i z_i} \mathcal{I}_{\text{FI}}(\mathbf{w}, \mathbf{n}, \mathbf{z}, \mathbf{a}) \mathcal{I}_{\text{vector}}(\mathbf{z}, \mathbf{a}; \tilde{q}, \tilde{t}) \\ &\times \mathcal{I}_{\text{half-hyper}}^{\mathcal{R}}(\mathbf{z}, \mathbf{a}, \tilde{\mathbf{z}}, \tilde{\mathbf{a}}; \tilde{q}, \tilde{t}), \end{aligned} \quad (\text{B.7})$$

where $W(\mathbf{a})$ is the order of the Weyl symmetry group left unbroken by the fluxes \mathbf{a} , and the contour of integration is $\mathcal{C} = \prod_{i=1}^{\text{rank}G} \mathcal{C}_i$ with \mathcal{C}_i being a unit circle around the origin on the i -th complex plane.¹⁹ The integrands \mathcal{I}_{FI} , $\mathcal{I}_{\text{vector}}$ and $\mathcal{I}_{\text{half-hyper}}^{\mathcal{R}}$ are given as follows.

$$\mathcal{I}_{\text{FI}}(\mathbf{w}, \mathbf{n}, \mathbf{z}, \mathbf{a}) = \left(\prod_{\beta} \prod_{i(\beta)} w_{\beta}^{a_{i(\beta)}} \cdot z_{i(\beta)}^{n_{\beta}} \right), \quad (\text{B.8})$$

$$\begin{aligned} \mathcal{I}_{\text{vector}}(\mathbf{z}, \mathbf{a}; \tilde{q}, \tilde{t}) &= \left(\frac{(\tilde{t}\tilde{q}^{1/2}; \tilde{q})}{(\tilde{t}^{-1}\tilde{q}^{1/2}; \tilde{q})} \right)^{\text{rank}G} \prod_{\alpha \in \text{ad}(G)} (1 - \tilde{q}^{|\alpha|/2} e^{2\pi i \alpha(\mathbf{s})}) \\ &\times \left(\frac{\tilde{q}^{1/2}}{\tilde{t}} \right)^{-|\alpha(\mathbf{a})|/2} \frac{(\tilde{t}\tilde{q}^{1/2+|\alpha(\mathbf{a})|/2} e^{2\pi i \alpha(\mathbf{s})}; \tilde{q})}{(\tilde{t}^{-1}\tilde{q}^{1/2+|\alpha(\mathbf{a})|/2} e^{2\pi i \alpha(\mathbf{s})}; \tilde{q})}, \end{aligned} \quad (\text{B.9})$$

$$\begin{aligned} \mathcal{I}_{\text{half-hyper}}^{\mathcal{R}}(\mathbf{z}, \mathbf{a}, \tilde{\mathbf{z}}, \tilde{\mathbf{a}}; \tilde{q}, \tilde{t}) &= \prod_{\rho \in \mathcal{R}(G \times G_H)} \left(\frac{\tilde{q}^{1/2}}{\tilde{t}} \right)^{-|\rho(\mathbf{a}, \tilde{\mathbf{a}})|/4} \\ &\times \frac{(\tilde{t}^{-1/2}\tilde{q}^{3/4+|\rho(\mathbf{a}, \tilde{\mathbf{a}})|/2} e^{2\pi i \rho(\mathbf{s}, \tilde{\mathbf{s}})}; \tilde{q})}{(\tilde{t}^{1/2}\tilde{q}^{1/4+|\rho(\mathbf{a}, \tilde{\mathbf{a}})|/2} e^{2\pi i \rho(\mathbf{s}, \tilde{\mathbf{s}})}; \tilde{q})}, \end{aligned} \quad (\text{B.10})$$

where α is a root of the Lie algebra of G , ρ is a weight of the representation \mathcal{R} of the Lie

¹⁹A 3d $\mathcal{N} = 4$ hypermultiplet consists of a half-hyper in the representation \mathcal{R} and another half-hyper in the complex conjugate representation \mathcal{R}^* . For pseudo-real representations, one presents the matter content in terms of half-hypers.

algebra of $G \times G_H$, $(z; \tilde{q})$ is the Pochhammer symbol defined as

$$(z; \tilde{q}) := \prod_{l=0}^{\infty} (1 - z\tilde{q}^l), \quad |\tilde{q}| < 1, \tag{B.11}$$

and, for future use, the symbol $(z^\pm; q)$ is defined as $(z^\pm; q) = (z; q) \cdot (z^{-1}; q)$.

For a linear quiver gauge theory (X) with unitary gauge groups and (bi)fundamental matter, the expression for the index can be written as follows. Let the gauge group $G = \prod_{\gamma=1}^L U(N_\gamma)$ and the flavor symmetry group $G_H = \left(\prod_{\gamma=1}^L U(M_\gamma) \right) / U(1)$, and let us denote the fugacities and fluxes associated with the gauge nodes and flavor nodes as $\{\mathbf{z}^{(\gamma)}, \mathbf{a}^{(\gamma)}\}$ and $\{\tilde{\mathbf{z}}^{(\gamma)}, \tilde{\mathbf{a}}^{(\gamma)}\}$ respectively. We prefer to reorganize the gauge/flavor fugacities and fluxes as follows:

$$z_{\beta'} = \{z_{j_1}^{(1)}, z_{j_2}^{(2)}, \dots, z_{j_\alpha}^{(\alpha)}, \dots, z_{j_{L-1}}^{(L-1)}, z_{j_L}^{(L)}\}, \quad \beta' = 1, \dots, \sum_{\gamma} N_\gamma, \tag{B.12}$$

$$a_{\beta'} = \{a_{j_1}^{(1)}, a_{j_2}^{(2)}, \dots, a_{j_\alpha}^{(\alpha)}, \dots, a_{j_{L-1}}^{(L-1)}, a_{j_L}^{(L)}\}, \quad \beta' = 1, \dots, \sum_{\gamma} N_\gamma, \tag{B.13}$$

$$\tilde{z}_\beta = \{\tilde{z}_{i_1}^{(1)}, \tilde{z}_{i_2}^{(2)}, \dots, \tilde{z}_{i_\alpha}^{(\alpha)}, \dots, \tilde{z}_{i_{L-1}}^{(L-1)}, \tilde{z}_{i_L}^{(L)}\}, \quad \beta = 1, \dots, L^\vee + 1, \tag{B.14}$$

$$\tilde{a}_\beta = \{\tilde{a}_{i_1}^{(1)}, \tilde{a}_{i_2}^{(2)}, \dots, \tilde{a}_{i_\alpha}^{(\alpha)}, \dots, \tilde{a}_{i_{L-1}}^{(L-1)}, \tilde{a}_{i_L}^{(L)}\}, \quad \beta = 1, \dots, L^\vee + 1, \tag{B.15}$$

with $i_1 = 1, \dots, M_1$, $i_2 = 1, \dots, M_2, \dots$, $i_\alpha = 1, \dots, M_\alpha$, $i_L = 1, \dots, M_L$, and $L^\vee = \sum_{\gamma=1}^L M_\gamma - 1$. In addition, we parametrize the $U(1)_J$ fugacities and fluxes (w_γ, n_γ) as follows:

$$w_\gamma = \frac{y_\gamma}{y_{\gamma+1}}, \quad n_\gamma = b_\gamma - b_{\gamma+1}, \quad \gamma = 1, \dots, L. \tag{B.16}$$

The index of (X) can then be written as the following contour integral:

$$\begin{aligned} \mathcal{I}^{(X)}(\tilde{\mathbf{z}}, \tilde{\mathbf{a}}, \mathbf{y}, \mathbf{b}; \tilde{q}, \tilde{t}) &= \sum_{\{\mathbf{a}^{(\gamma)}\}} \oint_{|z_{i_\gamma}^{(\gamma)}|=1} \prod_{\gamma=1}^L \left[\frac{d\mathbf{z}^{(\gamma)}}{\mathbf{z}^{(\gamma)}} \right] \mathcal{I}_{\text{int}}^{(X)}(\mathbf{z}, \mathbf{a}, \tilde{\mathbf{z}}, \tilde{\mathbf{a}}, \mathbf{y}, \mathbf{b}; \tilde{q}, \tilde{t}) \\ &= \sum_{\{\mathbf{a}^{(\gamma)}\}} \oint_{|z_{i_\gamma}^{(\gamma)}|=1} \prod_{\gamma=1}^L \left[\frac{d\mathbf{z}^{(\gamma)}}{\mathbf{z}^{(\gamma)}} \right] \mathcal{I}_{\text{FI}}^{(X)}(\mathbf{y}, \mathbf{b}, \{\mathbf{z}^{(\gamma)}\}, \{\mathbf{a}^{(\gamma)}\}) \mathcal{I}_{1\text{-loop}}^{(X)}(\mathbf{z}, \mathbf{a}, \tilde{\mathbf{z}}, \tilde{\mathbf{a}}; \tilde{q}, \tilde{t}) \\ &= \sum_{\{\mathbf{a}^{(\gamma)}\}} \oint_{|z_{i_\gamma}^{(\gamma)}|=1} \left[\frac{d\mathbf{z}^{(\gamma)}}{\mathbf{z}^{(\gamma)}} \right] \mathcal{I}_{\text{FI}}^{(X)}(\mathbf{y}, \mathbf{b}, \{\mathbf{z}^{(\gamma)}\}, \{\mathbf{a}^{(\gamma)}\}) \prod_{\gamma=1}^L \mathcal{I}_{\text{vector}}^{(X)}(\mathbf{z}^{(\gamma)}, \mathbf{a}^{(\gamma)}; \tilde{q}, \tilde{t}) \\ &\quad \times \prod_{\gamma=1}^L \mathcal{I}_{\text{hyper}}^{(X) \text{ fund.}}(\mathbf{z}^{(\gamma)}, \mathbf{a}^{(\gamma)}, \tilde{\mathbf{z}}^{(\gamma)}, \tilde{\mathbf{a}}^{(\gamma)}; \tilde{q}, \tilde{t}) \prod_{\gamma=1}^{L-1} \mathcal{I}_{\text{hyper}}^{(X) \text{ bifund.}}(\mathbf{z}^{(\gamma)}, \mathbf{a}^{(\gamma)}, \mathbf{z}^{(\gamma+1)}, \mathbf{a}^{(\gamma+1)}; \tilde{q}, \tilde{t}), \end{aligned} \tag{B.17}$$

where $\left[\frac{dz^{(\gamma)}}{z^{(\gamma)}}\right] = \frac{1}{W(\mathbf{a}^{(\gamma)})} \prod_{i_\gamma=1}^{N_\gamma} \frac{dz_{i_\gamma}^{(\gamma)}}{2\pi i z_{i_\gamma}^{(\gamma)}}$. The constituent functions inside the integrand are given as

$$\mathcal{I}_{\text{FI}}^{(X)}(\mathbf{y}, \mathbf{b}, \{\mathbf{z}^{(\gamma)}\}, \{\mathbf{a}^{(\gamma)}\}) = \prod_{\gamma=1}^L \left(\prod_{j_\gamma=1}^{N_\gamma} \left(\frac{y_{j_\gamma}}{y_{\gamma+1}} \right)^{a_{j_\gamma}^{(\gamma)}} \cdot (z_{j_\gamma}^{(\gamma)})^{(b_\gamma - b_{\gamma+1})} \right), \quad (\text{B.18})$$

$$\begin{aligned} \mathcal{I}_{\text{vector}}^{(X)}(\mathbf{z}^{(\gamma)}, \mathbf{a}^{(\gamma)}; \tilde{q}, \tilde{t}) &= \left(\frac{(\tilde{t}\tilde{q}^{1/2}; \tilde{q})}{(\tilde{t}^{-1}\tilde{q}^{1/2}; \tilde{q})} \right)^{N_\gamma} \prod_{k_\gamma \neq j_\gamma} (1 - \tilde{q}^{-|a_{k_\gamma}^{(\gamma)} - a_{j_\gamma}^{(\gamma)}|/2} z_{k_\gamma}^{(\gamma)} / z_{j_\gamma}^{(\gamma)}) \\ &\times \left(\frac{\tilde{q}^{1/2}}{\tilde{t}} \right)^{-|a_{k_\gamma}^{(\gamma)} - a_{j_\gamma}^{(\gamma)}|/2} \frac{(\tilde{t}\tilde{q}^{-1/2 + |a_{k_\gamma}^{(\gamma)} - a_{j_\gamma}^{(\gamma)}|/2} z_{k_\gamma}^{(\gamma)} / z_{j_\gamma}^{(\gamma)}; \tilde{q})}{(\tilde{t}^{-1}\tilde{q}^{-1/2 + |a_{k_\gamma}^{(\alpha)} - a_{j_\gamma}^{(\alpha)}|/2} z_{k_\gamma}^{(\gamma)} / z_{j_\gamma}^{(\gamma)}; \tilde{q})}, \end{aligned} \quad (\text{B.19})$$

$$\begin{aligned} \mathcal{I}_{\text{hyper}}^{(X)\text{fund.}}(\mathbf{z}^{(\gamma)}, \mathbf{a}^{(\gamma)}, \tilde{\mathbf{z}}^{(\gamma)}, \tilde{\mathbf{a}}^{(\gamma)}; \tilde{q}, \tilde{t}) &= \prod_{i_\gamma=1}^{M_\gamma} \prod_{j_\gamma=1}^{N_\gamma} \left(\frac{\tilde{q}^{1/2}}{\tilde{t}} \right)^{|a_{j_\gamma}^{(\gamma)} - \tilde{a}_{i_\gamma}^{(\gamma)}|/2} \\ &\times \frac{(\tilde{t}^{-1/2}\tilde{q}^{3/4 + |a_{j_\gamma}^{(\gamma)} - \tilde{a}_{i_\gamma}^{(\alpha)}|/2} (z_{j_\gamma}^{(\gamma)} / \tilde{z}_{i_\gamma}^{(\gamma)})^\pm; \tilde{q})}{(\tilde{t}^{1/2}\tilde{q}^{-1/4 + |a_{j_\gamma}^{(\gamma)} - \tilde{a}_{i_\gamma}^{(\gamma)}|/2} (z_{j_\gamma}^{(\gamma)} / \tilde{z}_{i_\gamma}^{(\gamma)})^\pm; \tilde{q})}, \end{aligned} \quad (\text{B.20})$$

$$\begin{aligned} \mathcal{I}_{\text{hyper}}^{(X)\text{bifund.}}(\mathbf{z}^{(\gamma)}, \mathbf{a}^{(\gamma)}, \mathbf{z}^{(\gamma+1)}, \mathbf{a}^{(\gamma+1)}; \tilde{q}, \tilde{t}) &= \prod_{k_\gamma=1}^{N_\gamma} \prod_{j_\gamma=1}^{N_{\gamma+1}} \left(\frac{\tilde{q}^{1/2}}{\tilde{t}} \right)^{|a_{k_\gamma}^{(\alpha)} - a_{j_\gamma}^{(\gamma+1)}|/2} \\ &\times \frac{(\tilde{t}^{-1/2}\tilde{q}^{3/4 + |a_{k_\gamma}^{(\gamma)} - a_{j_\gamma}^{(\gamma+1)}|/2} (z_{k_\gamma}^{(\gamma)} / z_{j_\gamma}^{(\gamma+1)})^\pm; \tilde{q})}{(\tilde{t}^{1/2}\tilde{q}^{-1/4 + |a_{k_\gamma}^{(\gamma)} - a_{j_\gamma}^{(\gamma+1)}|/2} (z_{k_\gamma}^{(\gamma)} / z_{j_\gamma}^{(\gamma+1)})^\pm; \tilde{q})}. \end{aligned} \quad (\text{B.21})$$

The Coulomb and the Higgs limits of the superconformal index admit expansions in terms of characters of representations of the respective global symmetry groups — G_H and G_C . In fact, these limits coincide with the Coulomb branch Hilbert Series and the Higgs branch Hilbert Series respectively. Schematically, one can write

$$\mathcal{I}_C(\tilde{x}; \mu_i) = \sum_{\mathbf{k}=0}^{\infty} \chi[\mathcal{R}_{\mathbf{k}}(G_C)](\mu_i) \tilde{x}^{|\mathbf{k}|}, \quad (\text{B.22})$$

$$\mathcal{I}_H(x; \mu_i) = \sum_{\mathbf{k}=0}^{\infty} \chi[\mathcal{R}_{\mathbf{k}}(G_H)](\mu_i) x^{|\mathbf{k}|}, \quad (\text{B.23})$$

where $\mathcal{R}_{\mathbf{k}}$ are irreducible representations labelled by the Dynkin labels \mathbf{k} , and $\chi[\mathcal{R}_{\mathbf{k}}(G)](\mu_i)$ denotes the associated character as a function of the fugacities $\{\mu_i\}$. Therefore, a series expansion of the Coulomb and the Higgs indices in terms of \tilde{x} and x respectively can be used to read off the global symmetries of the respective branches.

B.2 3d $\mathcal{N} = 4$ mirror symmetry

The basic example of 3d $\mathcal{N} = 4$ mirror symmetry involves an SQED with a single hypermultiplet on one side and a twisted hypermultiplet on the other. 3d mirror symmetry therefore implies the following identity:

$$\begin{aligned} \mathcal{I}_{\text{SQED}_1}(w, n; \tilde{q}, \tilde{t}) &= \mathcal{I}_{\text{twisted hyper}}(w, n, 1, 0; \tilde{q}, \tilde{t}) = \mathcal{I}_{\text{hyper}}(w, n, 1, 0; \tilde{q}, \tilde{t}^{-1}), \quad (\text{B.24}) \\ \implies \sum_{m \in \mathbb{Z}} w^m \oint_{|z|=1} \frac{dz z^n}{2\pi i z} \mathcal{I}_{\text{vector}}(\tilde{q}, \tilde{t}) \mathcal{I}_{\text{hyper}}(z, m, 1, 0; \tilde{q}, \tilde{t}) &= \mathcal{I}_{\text{hyper}}(w, n, 1, 0; \tilde{q}, \tilde{t}^{-1}). \end{aligned}$$

The index of a “twisted hypermultiplet” is given by substituting $\tilde{t} \rightarrow \tilde{t}^{-1}$ in the index of a hypermultiplet. Replacing $\tilde{t} \rightarrow \tilde{t}^{-1}$, the above identity can be written in the following form:

$$\mathcal{I}_{\text{hyper}}(w, n, 1, 0; \tilde{q}, \tilde{t}) = \sum_{m \in \mathbb{Z}} w^m \oint_{|z|=1} \frac{dz z^n}{2\pi i z} \mathcal{I}_{\text{vector}}(\tilde{q}, \tilde{t}^{-1}) \mathcal{I}_{\text{hyper}}(z, m, 1, 0; \tilde{q}, \tilde{t}^{-1}). \quad (\text{B.25})$$

Parametrizing $w = y_1/y_2$ and $n = b_1 - b_2$, this identity can be written in a form that will be useful in our analysis of Abelian S -type operations:

$$\mathcal{I}_{\text{hyper}}(y_1, b_1, y_2, b_2; \tilde{q}, \tilde{t}) = \sum_{m \in \mathbb{Z}} \left(\frac{y_1}{y_2} \right)^m \oint_{|z|=1} \frac{dz z^{b_1 - b_2}}{2\pi i z} \mathcal{I}_{\text{vector}}(\tilde{q}, \tilde{t}^{-1}) \mathcal{I}_{\text{hyper}}(z, m, 1, 0; \tilde{q}, \tilde{t}^{-1}). \quad (\text{B.26})$$

Now consider a pair of linear quivers (X, Y) , where the index of X is given by (B.17). In the standard notation, introduced in section 2.4, the statement of 3d mirror symmetry is

$$\mathcal{I}^{(X)}(\tilde{z}, \tilde{\mathbf{a}}, \mathbf{y}, \mathbf{b}; \tilde{q}, \tilde{t}) = \mathcal{I}^{(Y)}(\mathbf{y}^{-1}, -\mathbf{b}, \tilde{z}, \tilde{\mathbf{a}}; \tilde{q}, \tilde{t}^{-1}), \quad (\text{B.27})$$

where the index $\mathcal{I}^{(Y)}(\mathbf{y}, \mathbf{b}, \tilde{z}, \tilde{\mathbf{a}}; \tilde{q}, \tilde{t})$ is given as

$$\begin{aligned} \mathcal{I}^{(Y)}(\mathbf{y}, \mathbf{b}, \tilde{z}, \tilde{\mathbf{a}}; \tilde{q}, \tilde{t}) &= \sum_{\{\mathbf{c}^{(\gamma')}\}} \prod_{\gamma'=1}^{L^\vee} \oint_{|\xi_{i_{\gamma'}}^{(\gamma')}|=1} \left[\frac{d\xi^{(\gamma')}}{\xi^{(\gamma')}} \right] \mathcal{I}_{\text{int}}^{(Y)}(\boldsymbol{\xi}, \mathbf{c}, \mathbf{y}, \mathbf{b}, \tilde{z}, \tilde{\mathbf{a}}; \tilde{q}, \tilde{t}) \quad (\text{B.28}) \\ &= \sum_{\{\mathbf{c}^{(\gamma')}\}} \prod_{\gamma'=1}^{L^\vee} \oint_{|\xi_{i_{\gamma'}}^{(\gamma')}|=1} \left[\frac{d\xi^{(\gamma')}}{\xi^{(\gamma')}} \right] \mathcal{I}_{\text{FI}}^{(Y)}(\tilde{z}, \tilde{\mathbf{a}}, \{\boldsymbol{\xi}^{(\gamma')}\}, \{\mathbf{c}^{(\gamma')}\}) \mathcal{I}_{1\text{-loop}}^{(Y)}(\boldsymbol{\xi}, \mathbf{c}, \mathbf{y}, \mathbf{b}; \tilde{q}, \tilde{t}) \\ &= \sum_{\{\mathbf{c}^{(\gamma')}\}} \prod_{\gamma'=1}^{L^\vee} \oint_{|\xi_{i_{\gamma'}}^{(\gamma')}|=1} \left[\frac{d\xi^{(\gamma')}}{\xi^{(\gamma')}} \right] \mathcal{I}_{\text{FI}}^{(Y)}(\tilde{z}, \tilde{\mathbf{a}}, \{\boldsymbol{\xi}^{(\gamma')}\}, \{\mathbf{c}^{(\gamma')}\}) \prod_{\gamma'=1}^{L^\vee} \mathcal{I}_{\text{vector}}^{(Y)}(\boldsymbol{\xi}^{(\gamma')}, \mathbf{c}^{(\gamma')}; \tilde{q}, \tilde{t}) \\ &\quad \times \prod_{\gamma=1}^L \mathcal{I}_{\text{matter}}^{(Y)\text{fund.}}(\boldsymbol{\xi}^{(\gamma')}, \mathbf{c}^{(\gamma')}, \mathbf{y}^{(\gamma')}, \mathbf{b}^{(\gamma')}; \tilde{q}, \tilde{t}) \prod_{\gamma=1}^{L-1} \mathcal{I}_{\text{matter}}^{(Y)\text{bifund.}}(\boldsymbol{\xi}^{(\gamma')}, \mathbf{c}^{(\gamma')}, \boldsymbol{\xi}^{(\gamma'+1)}, \mathbf{c}^{(\gamma'+1)}; \tilde{q}, \tilde{t}). \end{aligned}$$

The FI term in the integrand is given as

$$\mathcal{I}_{\text{FI}}^{(Y)}(\tilde{z}, \tilde{\mathbf{a}}, \{\boldsymbol{\xi}^{(\gamma')}\}, \{\mathbf{c}^{(\gamma')}\}) = \prod_{\gamma'=1}^{L^\vee} \left(\prod_{j_{\gamma'}=1}^{N_{\gamma'}} \left(\frac{\tilde{z}_{\gamma'}}{\tilde{z}_{\gamma'+1}} \right)^{c_{j_{\gamma'}}^{(\gamma')}} \cdot (\boldsymbol{\xi}_{j_{\gamma'}}^{(\gamma')})^{\tilde{a}_{\gamma'} - \tilde{a}_{\gamma'+1}} \right), \quad (\text{B.29})$$

while the one-loop terms are given by expressions analogous to (B.19)–(B.21).

C S -type operations in terms of the superconformal index

In this section, we demonstrate how the elementary S -type operations can be implemented in terms of the superconformal index on $S^2 \times S^1$. For new dualities, the equality of the indices serves as another strong check. In appendix C.1, we first discuss the implementation of elementary S -type operations on linear quivers, and then extend it to generic quivers in class \mathcal{U} . We then discuss the four elementary Abelian S -type operations in appendix C.2, explicitly working out the dual operation in each case, as we did in section 4.1 using the S^3 partition function. All examples studied in section 4 can be constructed using the expressions for the dual superconformal indices in appendix C.2. As an illustrative example, we work out the case of a flavored \hat{A}_{n-1} quiver and the Family $\text{I}_{[n,l,p]}$ explicitly in appendix C.3.

C.1 Generic S -type operations and their duals

The S -type operations and their duals can be implemented in terms of the $S^2 \times S^1$ superconformal index, following steps analogous to those for the partition function on S^3 . Consider the linear quiver gauge theory X in figure 3. The index of the theory is given in (B.17) as function of various global symmetry fugacities and fluxes. The fugacities and fluxes associated with a flavor node (γ) is denoted as $(\tilde{\mathbf{z}}^{(\gamma)}, \tilde{\mathbf{a}}^{(\gamma)})$, where the fugacities are related to the masses as follows:

$$\tilde{\mathbf{z}}^{(\gamma)} = e^{2\pi i \mathbf{m}^\gamma}, \quad \gamma = 1, \dots, L, \quad (\text{C.1})$$

where \mathbf{m}^γ are complex parameters. In addition, the $U(1)_J$ fugacities and fluxes associated with the gauge nodes are denoted as $(\{w_\gamma\}, \{n_\gamma\})$. It is convenient to parametrize them in terms of the pair (\mathbf{y}, \mathbf{b}) such that

$$w_\gamma = \frac{y_\gamma}{y_{\gamma+1}}, \quad n_\gamma = b_\gamma - b_{\gamma+1}, \quad \gamma = 1, \dots, L. \quad (\text{C.2})$$

The fugacities \mathbf{y} are related to the deformation parameter \mathbf{t} as:

$$\mathbf{y} = e^{2\pi i \mathbf{t}}, \quad (\text{C.3})$$

where \mathbf{t} are complex parameters. For further details on the convention of the fugacities and fluxes, the reader is referred to appendix B.

Now, consider picking a flavor node (α) corresponding to a global symmetry group $U(M_\alpha)$ in X and split it into two, as $U(r_\alpha) \times U(M_\alpha - r_\alpha)$.²⁰ Let us introduce a set of fugacities $\{h_i^{(\alpha)} | i = 1, \dots, r_\alpha\}$, and $\{h_j'^{(\alpha)} | j = 1, \dots, M_\alpha - r_\alpha\}$, such that $h_i^{(\alpha)}$ are valued in the maximal torus of $U(r_\alpha)$, and $h_j'^{(\alpha)}$ are valued in the maximal torus of $U(M_\alpha - r_\alpha)$. We will take these fugacities to be related to the $U(r_\alpha) \times U(M_\alpha - r_\alpha)$ masses $(\mathbf{u}^\alpha, \mathbf{v}^\alpha)$ defined in (3.1) in the following fashion (with complex $(\mathbf{u}^\alpha, \mathbf{v}^\alpha)$):

$$\mathbf{h}^{(\alpha)} = e^{2\pi i \mathbf{u}^\alpha}, \quad \mathbf{h}'^{(\alpha)} = e^{2\pi i \mathbf{v}^\alpha}. \quad (\text{C.4})$$

In terms of the fugacities $\tilde{\mathbf{z}}^{(\alpha)}$, $\mathbf{h}^{(\alpha)}$ and $\mathbf{h}'^{(\alpha)}$ are therefore given as

$$\tilde{z}_{i_\alpha}^{(\alpha)} = \prod_i (h_i^{(\alpha)})^{\mathcal{P}_{i_\alpha i}} \prod_j (h_j'^{(\alpha)})^{\mathcal{P}_{i_\alpha r_\alpha + j}}, \quad i_\alpha = 1, \dots, M_\alpha, \quad i = 1, \dots, r_\alpha, \quad j = 1, \dots, M_\alpha - r_\alpha, \quad (\text{C.5})$$

where \mathcal{P} is an $M_\alpha \times M_\alpha$ permutation matrix. In addition, we introduce fluxes $(\kappa^{(\alpha)}, \kappa'^{(\alpha)})$ for $U(r_\alpha) \times U(M_\alpha - r_\alpha)$, as follows:

$$\tilde{a}_{i_\alpha}^{(\alpha)} = \mathcal{P}_{i_\alpha i} \kappa_i^{(\alpha)} + \mathcal{P}_{i_\alpha r_\alpha + j} \kappa_j'^{(\alpha)}, \quad i_\alpha = 1, \dots, M_\alpha, \quad i = 1, \dots, r_\alpha, \quad j = 1, \dots, M_\alpha - r_\alpha. \quad (\text{C.6})$$

²⁰As noted earlier, we will assume that the masses associated with the flavor node α are completely unconstrained. The $U(1)$ quotient for the Higgs branch global symmetry in a linear quiver is implemented by imposing a constraint on the masses associated to the other flavor node(s).

The index of the quiver (X, \mathcal{P}) can then be written as a function of $\mathbf{s}_\alpha^X = (\mathbf{h}^{(\alpha)}, \boldsymbol{\kappa}^{(\alpha)})$, $\mathbf{s}'_\alpha^X = (\mathbf{h}'^{(\alpha)}, \boldsymbol{\kappa}'^{(\alpha)})$, $\boldsymbol{\Sigma}^X = (\{\tilde{\mathbf{z}}^{(\gamma)}\}, \{\tilde{\mathbf{a}}^{(\gamma)}\})_{\gamma \neq \alpha}$, and $\mathbf{s}_J^X = (\mathbf{y}, \mathbf{b})$, in addition to the R-symmetry fugacities, as follows:

$$\mathcal{I}^{(X, \mathcal{P})}(\mathbf{s}_\alpha^X, \mathbf{s}'_\alpha^X, \boldsymbol{\Sigma}^X, \mathbf{s}_J^X; \tilde{q}, \tilde{t}) =: \mathcal{I}^{(X)}(\tilde{\mathbf{z}}^{(\alpha)}(\mathcal{P}, \mathbf{h}^{(\alpha)}, \mathbf{h}'^{(\alpha)}), \tilde{\mathbf{a}}^{(\alpha)}(\mathcal{P}, \boldsymbol{\kappa}^{(\alpha)}, \boldsymbol{\kappa}'^{(\alpha)}), \boldsymbol{\Sigma}^X, \mathbf{s}_J^X; \tilde{q}, \tilde{t}). \quad (\text{C.7})$$

Generalization of the above formula where multiple flavor nodes, labelled by β , are split, is given by:

$$\mathcal{I}^{(X, \{\mathcal{P}_\beta\})}(\{\mathbf{s}_\beta^X, \mathbf{s}'_\beta^X\}, \boldsymbol{\Sigma}^X, \mathbf{s}_J^X; \tilde{q}, \tilde{t}) =: \mathcal{I}^{(X)}(\{\tilde{\mathbf{z}}^{(\beta)}(\mathcal{P}_\beta, \mathbf{h}^{(\beta)}, \mathbf{h}'^{(\beta)}), \tilde{\mathbf{a}}^{(\beta)}(\mathcal{P}_\beta, \boldsymbol{\kappa}^{(\beta)}, \boldsymbol{\kappa}'^{(\beta)})\}, \boldsymbol{\Sigma}^X, \mathbf{s}_J^X; \tilde{q}, \tilde{t}), \quad (\text{C.8})$$

where $\boldsymbol{\Sigma}^X$ is now defined as $\boldsymbol{\Sigma}^X = (\{\tilde{\mathbf{z}}^{(\gamma)}\}, \{\tilde{\mathbf{a}}^{(\gamma)}\})_{\gamma \neq \beta}$, with $\mathbf{s}_\beta^X = (\mathbf{h}^{(\beta)}, \boldsymbol{\kappa}^{(\beta)})$ and $\mathbf{s}'_\beta^X = (\mathbf{h}'^{(\beta)}, \boldsymbol{\kappa}'^{(\beta)})$. The fluxes/fugacities associated with the node β are defined as before:

$$\tilde{z}_{i_\beta}^{(\beta)} = \prod_i (h_i^{(\beta)})^{\mathcal{P}_{\beta \ i_\beta i}} \prod_j (h_j'^{(\beta)})^{\mathcal{P}_{\beta \ i_\beta r_\alpha + j}}, \quad (\text{C.9})$$

$$\tilde{a}_{i_\beta}^{(\beta)} = \mathcal{P}_{\beta \ i_\beta i} \kappa_i^{(\beta)} + \mathcal{P}_{\beta \ i_\beta r_\alpha + j} \kappa_j'^{(\beta)}, \quad (\text{C.10})$$

where $i_\beta = 1, \dots, M_\beta$, $i = 1, \dots, r_\alpha$, and $j = 1, \dots, M_\beta - r_\alpha$, with \mathcal{P}_β being an $M_\beta \times M_\beta$ permutation matrix.

An elementary S -type operation $\mathcal{O}_{\mathcal{P}}^\alpha$ on the quiver gauge theory X can then be implemented in terms of the superconformal index as follows:

$$\mathcal{I}^{\mathcal{O}_{\mathcal{P}}^\alpha(X)} = \sum_{\boldsymbol{\kappa}^{(\alpha)} | h_i^{(\alpha)} = 1} \oint \left[\frac{d\mathbf{h}^{(\alpha)}}{\mathbf{h}^{(\alpha)}} \right] \mathcal{I}_{\mathcal{O}_{\mathcal{P}}^\alpha(X)}(\mathbf{s}_\alpha^X, \{\mathbf{s}_\beta^X\}, \mathbf{s}_F^\mathcal{O}, \mathbf{s}_J^\mathcal{O}; \tilde{q}, \tilde{t}) \cdot \mathcal{I}^{(X, \{\mathcal{P}_\beta\})}(\{\mathbf{s}_\beta^X, \mathbf{s}'_\beta^X\}, \boldsymbol{\Sigma}^X, \mathbf{s}_J^X; \tilde{q}, \tilde{t}), \quad (\text{C.11})$$

where $\mathbf{s}_F^\mathcal{O}$ collectively denotes all the flavor fugacities and fluxes introduced by the operation $\mathcal{O}_{\mathcal{P}}^\alpha$, while $\mathbf{s}_J^\mathcal{O}$ collectively denotes the new $U(1)_J$ fugacity and flux. The integration measure $\left[\frac{d\mathbf{h}^{(\alpha)}}{\mathbf{h}^{(\alpha)}} \right] = \frac{1}{W(\boldsymbol{\kappa}^{(\alpha)})} \prod_i \frac{dh_i^{(\alpha)}}{2\pi i h_i^{(\alpha)}}$, where $|W(\boldsymbol{\kappa}^{(\alpha)})|$ is the order of the Weyl group of $U(r_\alpha)$ left unbroken by the fluxes $\boldsymbol{\kappa}^{(\alpha)}$.

For the elementary S -type operations discussed in section 3.2, the associated operator $\mathcal{I}_{\mathcal{O}_{\mathcal{P}}^\alpha(X)}$ can be constructed from the index contributions of the gauging, flavoring, identification and defect operations (introduced in section 3.1), which are given as follows:

- For a gauging operation $G_{\mathcal{P}}^\alpha$ at a flavor node α of quiver X :

$$\mathcal{I}_{G_{\mathcal{P}}^\alpha(X)}(\mathbf{s}_\alpha^X, \mathbf{s}_J^\mathcal{O}; \tilde{q}, \tilde{t}) = \mathcal{I}_{\text{FI}}(\tilde{w}, \tilde{n}, \mathbf{h}^{(\alpha)}, \boldsymbol{\kappa}^{(\alpha)}) \mathcal{I}_{\text{vector}}(\mathbf{h}^{(\alpha)}, \boldsymbol{\kappa}^{(\alpha)}; \tilde{q}, \tilde{t}), \quad (\text{C.12})$$

where $\mathbf{s}_J^\mathcal{O} = (\tilde{w}, \tilde{n})$ denotes the fugacity and flux for the $U(1)_J$ global symmetry introduced by the gauging operation.

- For a flavoring operation $F_{\mathcal{P}}^\alpha$ at a flavor node α of X :

$$\mathcal{I}_{F_{\mathcal{P}}^\alpha(X)}(\mathbf{s}_\alpha^X, \mathbf{s}_F^\mathcal{O}; \tilde{q}, \tilde{t}) = \mathcal{I}_{\text{hyper}}(\mathbf{h}^{(\alpha)}, \boldsymbol{\kappa}^{(\alpha)}, \tilde{\mathbf{h}}^{(\alpha)}, \tilde{\boldsymbol{\kappa}}^{(\alpha)}; \tilde{q}, \tilde{t}), \quad (\text{C.13})$$

where $\mathbf{s}_F^\mathcal{O} = (\tilde{\mathbf{h}}^{(\alpha)}, \tilde{\boldsymbol{\kappa}}^{(\alpha)})$ denotes the fugacities and fluxes for the flavor symmetry introduced by the flavoring operation.

- For an identification operation $I_{\mathcal{P}}^\alpha$, which involves p nodes of the linear quiver X labelled by $\beta = \{\gamma_1, \gamma_2, \dots, \gamma_p\}$:

$$\mathcal{I}_{I_{\mathcal{P}}^\alpha(X)}(\mathbf{s}_\alpha^X, \{\mathbf{s}_\beta^X\}_{\beta \neq \alpha}, \boldsymbol{\lambda}, \boldsymbol{\delta}; \tilde{q}, \tilde{t}) = \prod_{\beta} \prod_{i=1}^{r_\alpha} \oint_{C_\lambda} \frac{dh_i^{(\beta)}}{2\pi i (h_i^{(\beta)} - \lambda_\beta h_i^{(\alpha)})} \cdot \sum_{\{\boldsymbol{\kappa}^{(\beta)}\}} \delta_{\boldsymbol{\kappa}^{(\beta)}, \boldsymbol{\kappa}^{(\alpha)} + \boldsymbol{\delta}^\beta}, \quad (\text{C.14})$$

where $\lambda_\beta = e^{2\pi i \mu^\beta}$, $\boldsymbol{\delta}^\beta$ is a set of integers, and the integration is performed over an infinitesimal closed contours C_λ around the simple poles $h_i^{(\beta)} = \lambda_\beta h_i^{(\alpha)}$. By redefining $\mathbf{h}^{(\alpha)}$ and $\boldsymbol{\kappa}^{(\alpha)}$, one can set $\lambda_{\beta'} = 1$ and $\boldsymbol{\delta}^{\beta'} = 0$ for a chosen $\beta' \in \{\gamma_1, \gamma_2, \dots, \gamma_p\}$.

- For a defect operation $D_{\mathcal{P}}^\alpha$ at a flavor node α of quiver X :

$$\mathcal{I}_{D_{\mathcal{P}}^\alpha(X)}(\mathbf{s}_\alpha^X, \mathcal{D}) = \mathcal{I}_{\text{defect}}(\mathbf{s}_\alpha^X, \mathcal{D}), \quad (\text{C.15})$$

where \mathcal{D} denotes the additional data associated with the defect introduced, and $\mathcal{I}_{\text{defect}}$ denotes the contribution of the defect to the index.

The explicit operator $\mathcal{I}_{\mathcal{O}_{\mathcal{P}}^\alpha(X)}$ can be constructed using the expressions for $\mathcal{I}_{G_{\mathcal{P}}^\alpha(X)}$, $\mathcal{I}_{F_{\mathcal{P}}^\alpha(X)}$, $\mathcal{I}_{I_{\mathcal{P}}^\alpha(X)}$ and $\mathcal{I}_{D_{\mathcal{P}}^\alpha(X)}$ following the composition rule (3.15):

$$\mathcal{I}_{\mathcal{O}_{\mathcal{P}}^\alpha(X)} = \mathcal{I}_{G_{\mathcal{P}}^\alpha(X)} \cdot \left(\mathcal{I}_{F_{\mathcal{P}}^\alpha(X)}\right)^{n_3} \cdot \left(\mathcal{I}_{I_{\mathcal{P}}^\alpha(X)}\right)^{n_2} \cdot \left(\mathcal{I}_{D_{\mathcal{P}}^\alpha(X)}\right)^{n_1}. \quad (\text{C.16})$$

Now, let Y be the linear quiver which is mirror dual to the quiver X . Three-dimensional mirror symmetry implies:

$$\mathcal{I}^{(X)}(\tilde{\mathbf{z}}, \tilde{\mathbf{a}}, \mathbf{y}, \mathbf{b}; \tilde{q}, \tilde{t}) = \mathcal{I}^{(Y)}(\mathbf{y}^{-1}, -\mathbf{b}, \tilde{\mathbf{z}}, \tilde{\mathbf{a}}; \tilde{q}, \tilde{t}^{-1}) \quad (\text{C.17})$$

$$\implies \mathcal{I}^{(X, \{\mathcal{P}_\beta\})}(\{\mathbf{s}_\beta^X, \mathbf{s}'_\beta^X\}, \boldsymbol{\Sigma}^X, \mathbf{y}, \mathbf{b}; \tilde{q}, \tilde{t}) = \mathcal{I}^{(Y, \{\mathcal{P}_\beta\})}(\mathbf{y}^{-1}, -\mathbf{b}, \{\mathbf{s}_\beta^X, \mathbf{s}'_\beta^X\}, \boldsymbol{\Sigma}^X; \tilde{q}, \tilde{t}^{-1}). \quad (\text{C.18})$$

where the expression for $\mathcal{I}^{(Y, \{\mathcal{P}_\beta\})}$ can be read off from the index of quiver Y given in (B.28), using the relations (C.1), (C.5), and (C.6). Proceeding in an analogous fashion as the round sphere partition function analysis in section 3.3, one can write down the operation on quiver Y which is dual to the operation $\mathcal{O}_{\mathcal{P}}^\alpha$ on the quiver X . Let \mathbf{S} and \mathbf{S}_J denote the fugacities/fluxes associated with G_H and G_C respectively of the dual theory $\tilde{\mathcal{O}}_{\mathcal{P}}^\alpha(Y)$. Then, the index of the dual theory is

$$\begin{aligned} & \mathcal{I}^{\tilde{\mathcal{O}}_{\mathcal{P}}^\alpha(Y)}(\mathbf{S}(\mathbf{s}_J^X, \mathbf{s}_J^\mathcal{O}), \mathbf{S}_J(\{\mathbf{s}'_\beta^X\}, \mathbf{s}_F^\mathcal{O}, \boldsymbol{\Sigma}^X); \tilde{q}, \tilde{t}^{-1}) \\ &= \sum_{\{\mathbf{c}^{(\gamma')}\}_{\gamma'=1}^{L^\vee}} \prod_{|\xi_{i,\gamma'}^{(\gamma')}|=1} \oint \left[\frac{d\xi^{(\gamma')}}{\xi^{(\gamma')}} \right] \mathcal{I}_{\tilde{\mathcal{O}}_{\mathcal{P}}^\alpha(Y)}(\boldsymbol{\xi}, \mathbf{c}, \mathbf{s}_J^\mathcal{O}, \mathbf{s}_F^\mathcal{O}; \tilde{q}, \tilde{t}) \cdot \mathcal{I}_{\text{int}}^{(Y, \{\mathcal{P}_\beta\})}(\boldsymbol{\xi}, \mathbf{c}, \mathbf{y}^{-1}, -\mathbf{b}, \{\mathbf{s}_\beta^{(0)X}, \mathbf{s}'_\beta^X\}, \boldsymbol{\Sigma}^X; \tilde{q}, \tilde{t}^{-1}), \end{aligned} \quad (\text{C.19})$$

where $\mathbf{s}_\beta^{(0)X} = (\mathbf{1}, \mathbf{0})_\beta$ (i.e. setting the fugacities for $U(r_\alpha)_\beta$ to 1 and the fluxes to zero for all β), and the function $\mathcal{I}_{\text{int}}^{(Y, \{\mathcal{P}_\beta\})}$ is the integrand for the index of $(Y, \{\mathcal{P}_\beta\})$ as defined in (B.28). The function $\mathcal{I}_{\tilde{\mathcal{O}}_{\mathcal{P}}^\alpha(Y)}$ can be written in terms of the function $\mathcal{I}_{\mathcal{O}_{\mathcal{P}}^\alpha(X)}$ appearing in (C.11) as follows:

$$\begin{aligned} \mathcal{I}_{\tilde{\mathcal{O}}_{\mathcal{P}}^\alpha(Y)}(\boldsymbol{\xi}, \mathbf{c}, \mathbf{s}_J^\mathcal{O}, \mathbf{s}_F^\mathcal{O}; \tilde{q}, \tilde{t}) &= \sum_{\boldsymbol{\kappa}^{(\alpha)}} \oint_{|h_i^{(\alpha)}|=1} \left[\frac{dh^{(\alpha)}}{h^{(\alpha)}} \right] \mathcal{I}_{\mathcal{O}_{\mathcal{P}}^\alpha(X)}(\mathbf{s}_\alpha^X, \{\mathbf{s}_\beta^X\}, \mathbf{s}_F^\mathcal{O}, \mathbf{s}_J^\mathcal{O}; \tilde{q}, \tilde{t}) \\ &\times \mathcal{I}_{\text{FI}}^{(0)(Y, \{\mathcal{P}_\beta\})}(\boldsymbol{\xi}, \mathbf{c}, \{\mathbf{s}_\beta^X\}), \end{aligned} \quad (\text{C.20})$$

where $\mathcal{I}_{\text{FI}}^{(0)(Y, \{\mathcal{P}_\beta\})}$ is the part of the FI contribution which depends on $\{\mathbf{s}_\beta^X\} = \{\mathbf{h}^{(\beta)}, \boldsymbol{\kappa}^{(\beta)}\}$, i.e.

$$\mathcal{I}_{\text{FI}}^{(0)(Y, \{\mathcal{P}_\beta\})}(\boldsymbol{\xi}, \mathbf{c}, \{\mathbf{s}_\beta^X\}) = \prod_{\beta} \prod_{i=1}^{r_\alpha} \left[\left(f_i^{(\beta)}(\boldsymbol{\xi}, \mathcal{P}_\beta) \right)^{\kappa_i^{(\beta)}} \cdot \left(h_i^{(\beta)} \right)^{g_{(\beta)}^i(\mathbf{c}, \mathcal{P}_\beta)} \right], \quad (\text{C.21})$$

$$g_{(\beta)}^i(\mathbf{c}, \mathcal{P}_\beta) = - \sum_{i_{\alpha'-1}} c_{i_{\alpha'-1}}^{(\alpha'-1)} + \sum_{i_{\alpha'}} c_{i_{\alpha'}}^{(\alpha')}, \quad (\text{C.22})$$

$$f_i^{(\beta)}(\boldsymbol{\xi}, \mathcal{P}_\beta) = \frac{\prod_{i_{\alpha'}} \xi_{i_{\alpha'}}^{(\alpha')}}{\prod_{i_{\alpha'-1}} \xi_{i_{\alpha'-1}}^{(\alpha'-1)}}, \quad \alpha' = M_1 + \dots + M_{\beta-1} + k_\beta, \quad 1 \leq k_\beta \leq M_\beta, \quad (\text{C.23})$$

where for a fixed i , k_β is determined by the condition that $\mathcal{P}_\beta i_{\beta i} = 1$ for some $i_\beta = k_\beta$ and vanishes otherwise. If the dual theory $\tilde{\mathcal{O}}_{\mathcal{P}}^\alpha(Y)$ is Lagrangian, one should be able to manipulate the r.h.s. of (C.19) to rewrite it in the standard form (B.7) and read off the gauge group and matter content.

Now let us generalize the above formulae for the case of a Lagrangian dual pair (X, Y) , where X is in class \mathcal{U} and not necessarily a linear quiver. The $U(r_\alpha) \times U(M_\alpha - r_\alpha)$ fugacities/fluxes associated with a node (α) of X (or the $U(r_\alpha) \times U(M_\beta - r_\alpha)$ fugacities/fluxes for multiple nodes labelled by β) are defined as before by (C.5)–(C.6) (or by (C.9)–(C.10)). The $U(1)_J$ fugacities/fluxes are parametrized by $\mathbf{s}_J^X = (\{w_\gamma\}, \{n_\gamma\})$, where γ labels the gauge nodes of quiver X (note that the fugacities/fluxes can be trivial for γ corresponding to a non-unitary gauge node). The S -type operation $\mathcal{O}_{\mathcal{P}}^\alpha$ is then implemented on the quiver X by (C.11), where the operator $\mathcal{S}_{\mathcal{O}_{\mathcal{P}}^\alpha(X)}$ is constructed from (C.16).

Mirror symmetry of X and Y again relates the indices of the theories in the following fashion:

$$\mathcal{I}^{(X, \{\mathcal{P}_\beta\})}(\{\mathbf{s}_\beta^X, \mathbf{s}'_\beta^X\}, \boldsymbol{\Sigma}^X, \mathbf{s}_J^X; \tilde{q}, \tilde{t}) = \mathcal{I}^{(Y, \{\mathcal{P}_\beta\})}(\mathbf{s}^Y(\mathbf{s}_J^X), \mathbf{s}_J^Y(\{\mathbf{s}_\beta^X, \mathbf{s}'_\beta^X\}, \boldsymbol{\Sigma}^X); \tilde{q}, \tilde{t}^{-1}), \quad (\text{C.24})$$

where \mathbf{s}^Y and \mathbf{s}_J^Y denote the fugacities/fluxes for the Higgs branch global symmetry and the Coulomb branch global symmetry of Y respectively. The dual index is then given as:

$$\begin{aligned} \mathcal{I}_{\mathcal{P}}^{\tilde{\alpha}(Y)}(\mathbf{S}(\mathbf{s}_J^X, \mathbf{s}_J^\mathcal{O}), \mathbf{S}_J(\{\mathbf{s}'_\beta^X\}, \mathbf{s}_F^\mathcal{O}, \boldsymbol{\Sigma}^X); \tilde{q}, \tilde{t}^{-1}) &= \sum_{\{\mathbf{c}^{(\gamma')}\}} \prod_{\gamma'} \oint_{|\xi_{i_{\gamma'}}^{(\gamma')}|=1} \left[\frac{d\xi^{(\gamma')}}{\xi^{(\gamma')}} \right] \mathcal{S}_{\tilde{\mathcal{O}}_{\mathcal{P}}^\alpha(Y)}(\boldsymbol{\xi}, \mathbf{c}, \mathbf{s}_J^\mathcal{O}, \mathbf{s}_F^\mathcal{O}; \tilde{q}, \tilde{t}) \\ &\times \mathcal{I}_{\text{int}}^{(Y, \{\mathcal{P}_\beta\})}(\boldsymbol{\xi}, \mathbf{c}, \mathbf{s}^Y(\mathbf{s}_J^X), \mathbf{s}_J^Y(\{\mathbf{s}_\beta^{(0)X}, \mathbf{s}'_\beta^X\}, \boldsymbol{\Sigma}^X); \tilde{q}, \tilde{t}^{-1}), \end{aligned} \quad (\text{C.25})$$

where \mathbf{S} and \mathbf{S}_J denote the fugacities/fluxes associated with G_H and G_C respectively of the dual theory $\tilde{\mathcal{O}}_{\mathcal{P}}^\alpha(Y)$, and γ' labels the gauge nodes of the quiver Y (which is not a linear quiver). The function $\mathcal{S}_{\tilde{\mathcal{O}}_{\mathcal{P}}^\alpha(Y)}$ is given as before

$$\begin{aligned} \mathcal{S}_{\tilde{\mathcal{O}}_{\mathcal{P}}^\alpha(Y)}(\boldsymbol{\xi}, \mathbf{c}, \mathbf{s}_J^\mathcal{O}, \mathbf{s}_F^\mathcal{O}; \tilde{q}, \tilde{t}) &= \sum_{\boldsymbol{\kappa}^{(\alpha)}} \oint_{|h_i^{(\alpha)}|=1} \left[\frac{dh^{(\alpha)}}{h^{(\alpha)}} \right] \mathcal{S}_{\mathcal{O}_{\mathcal{P}}^\alpha(X)}(\mathbf{s}_\alpha^X, \{\mathbf{s}_\beta^X\}, \mathbf{s}_F^\mathcal{O}, \mathbf{s}_J^\mathcal{O}; \tilde{q}, \tilde{t}) \\ &\times \mathcal{I}_{\text{FI}}^{(0)(Y, \{\mathcal{P}_\beta\})}(\boldsymbol{\xi}, \mathbf{c}, \{\mathbf{s}_\beta^X\}). \end{aligned} \quad (\text{C.26})$$

The function $\mathcal{I}_{\text{FI}}^{(0)(Y, \{\mathcal{P}_\beta\})}$ above can be read off from the mirror map of masses and FI parameters between the dual theories X and Y , and can be parametrized as follows:

$$\mathcal{I}_{\text{FI}}^{(0)(Y, \{\mathcal{P}_\beta\})}(\boldsymbol{\xi}, \mathbf{c}, \{\mathbf{s}_\beta^X\}) = \prod_\beta \prod_{i=1}^{r_\alpha} \left[\left(f_i^{(\beta)}(\boldsymbol{\xi}, \mathcal{P}_\beta) \right)^{\kappa_i^{(\beta)}} \cdot \left(h_i^{(\beta)} \right)^{g_{(\beta)}^i(\mathbf{c}, \mathcal{P}_\beta)} \right], \quad (\text{C.27})$$

$$g_{(\beta)}^i(\mathbf{c}, \mathcal{P}_\beta) = \sum_{\gamma'} e_i^{\gamma'}(\mathcal{P}_\beta) \sum_{j_{\gamma'}} c_{j_{\gamma'}}^{(\gamma')}, \quad (\text{C.28})$$

$$f_i^{(\beta)}(\boldsymbol{\xi}, \mathcal{P}_\beta) = \prod_{\gamma'} \left(\prod_{j_{\gamma'}} \xi_{j_{\gamma'}}^{(\gamma')} \right)^{e_i^{\gamma'}(\mathcal{P}_\beta)}, \quad (\text{C.29})$$

where $\{e_i^{\gamma'}(\mathcal{P}_\beta)\}$ are integers completely determined by the mirror map of (X, Y) and the permutation matrices $\{\mathcal{P}_\beta\}$.

C.2 Abelian elementary S -type operations

We now discuss the Abelian versions of the four elementary S -type operations on a dual pair of quiver gauge theories (X, Y) , with X being in class \mathcal{U} . In particular, we explicitly derive the formulae for the dual superconformal indices, and demonstrate that each such operation (we only consider flavoring by hypermultiplets with gauge charge 1) leads to a new pair of Lagrangian dual theories. Similar to the analysis of the round sphere partition function, this leads us to the following conclusion. If (X, Y) is a dual pair of quiver gauge theories, and X' is a quiver gauge theory that can be obtained by a series of elementary S -type operations on X , then the theory Y' (i.e. the dual of X') is guaranteed to be a Lagrangian theory. In addition, the Lagrangian for Y' can be read off, by implementing the formulae presented below, for each elementary S -type operation.

For our presentation of the flavoring operations below, we will restrict ourselves to the case of $N_F^\alpha = 1$, which is sufficient for constructing all the examples in this paper. The extension to the case of $N_F^\alpha > 1$ is straightforward and can be dealt with in a fashion analogous to the round sphere partition function analysis in section 4.1.

We will need two identities for manipulating some of the expressions that will appear below:

$$\oint_{|z|=1} \frac{dz}{2\pi iz} z^n = \delta_{n,0}, \quad (\text{C.30})$$

$$\oint_{|z|=1} \frac{dz}{2\pi iz} \left(\sum_{\kappa \in \mathbb{Z}} \left(\frac{z}{a} \right)^\kappa \right) F(z) = F(z)|_{\frac{z}{a}=1} = F(a). \quad (\text{C.31})$$

C.2.1 Gauging

The Abelian gauging operation $G_{\mathcal{P}}^\alpha$ at a flavor node α of the quiver gauge theory X is implemented as:

$$\mathcal{I}_{G_{\mathcal{P}}^\alpha(X)} = \sum_{\kappa^{(\alpha)}} \oint_{|h^{(\alpha)}|=1} \left[\frac{dh^{(\alpha)}}{h^{(\alpha)}} \right] \mathcal{I}_{G_{\mathcal{P}}^\alpha(X)}(\mathbf{s}_\alpha^X, \mathbf{s}_J^O; \tilde{q}, \tilde{t}) \cdot \mathcal{I}^{(X, \mathcal{P})}(\mathbf{s}_\alpha^X, \mathbf{s}_\alpha^X, \boldsymbol{\Sigma}^X, \mathbf{s}_J^X; \tilde{q}, \tilde{t}), \quad (\text{C.32})$$

$$\mathcal{I}_{G_{\mathcal{P}}^\alpha(X)}(\mathbf{s}_\alpha^X, \mathbf{s}_J^O; \tilde{q}, \tilde{t}) = \mathcal{I}_{\text{FI}}(\tilde{w}, \tilde{n}, h^{(\alpha)}, \kappa^{(\alpha)}) \mathcal{I}_{\text{vector}}(\tilde{q}, \tilde{t}) = \tilde{w}^{\kappa^{(\alpha)}} h^{(\alpha)\tilde{n}} \mathcal{I}_{\text{vector}}(\tilde{q}, \tilde{t}), \quad (\text{C.33})$$

where $\mathcal{I}_{\text{vector}}(\tilde{q}, \tilde{t})$ is the index of a U(1) vector multiplet. From (C.26), the function $\mathcal{I}_{\tilde{G}_{\mathcal{P}}^{\alpha}(Y)}$ is then given as

$$\mathcal{I}_{\tilde{G}_{\mathcal{P}}^{\alpha}(Y)}(\boldsymbol{\xi}, \mathbf{c}, \mathbf{s}_J^{\mathcal{O}}; \tilde{q}, \tilde{t}) = \sum_{\kappa^{(\alpha)}} \oint_{|h^{(\alpha)}|=1} \left[\frac{dh^{(\alpha)}}{h^{(\alpha)}} \right] \mathcal{I}_{G_{\mathcal{P}}^{\alpha}(X)}(\mathbf{s}_{\alpha}^X, \mathbf{s}_J^{\mathcal{O}}; \tilde{q}, \tilde{t}) \cdot \mathcal{I}_{\text{FI}}^{(0)(Y, \mathcal{P})}(\boldsymbol{\xi}, \mathbf{c}, \mathbf{s}_{\alpha}^X), \quad (\text{C.34})$$

where $\mathcal{I}_{\text{FI}}^{(0)(Y, \mathcal{P})}$ is the $(h^{(\alpha)}, \kappa^{(\alpha)})$ part of the FI term in the index of quiver Y . Explicitly, this function can be written as:

$$\mathcal{I}_{\text{FI}}^{(0)(Y, \mathcal{P})}(\boldsymbol{\xi}, \mathbf{c}, \mathbf{s}_{\alpha}^X) = \left(f^{(\alpha)}(\boldsymbol{\xi}, \mathcal{P}) \right)^{\kappa^{(\alpha)}} \cdot \left(h^{(\alpha)} \right)^{g_{(\alpha)}(\mathbf{c}, \mathcal{P})}, \quad (\text{C.35})$$

$$g_{(\alpha)}(\mathbf{c}, \mathcal{P}) = \sum_{\gamma'} e^{\gamma'}(\mathcal{P}) \sum_{j_{\gamma'}} c_{j_{\gamma'}}^{(\gamma')}, \quad (\text{C.36})$$

$$f^{(\alpha)}(\boldsymbol{\xi}, \mathcal{P}) = \prod_{\gamma'} \left(\prod_{j_{\gamma'}} \xi_{j_{\gamma'}}^{(\gamma')} \right)^{e^{\gamma'}(\mathcal{P})}, \quad (\text{C.37})$$

where $\{e^{\gamma'}(\mathcal{P})\}$ are integers completely determined by the mirror map between X and Y , and the permutation matrix \mathcal{P} . Following the general equation (C.25) and implementing the integration over $h^{(\alpha)}$ and the sum over κ^{α} (using the identities (C.30) and (C.31) respectively), the index of the dual theory $\tilde{G}_{\mathcal{P}}^{\alpha}(Y)$ is given as:

$$\begin{aligned} & \mathcal{I}_{\tilde{G}_{\mathcal{P}}^{\alpha}(Y)}(\mathcal{S}(\mathbf{s}_J^X, \mathbf{s}_J^{\mathcal{O}}), \mathcal{S}_J(\mathbf{s}_{\alpha}^X, \boldsymbol{\Sigma}^X); \tilde{q}, \tilde{t}^{-1}) \\ &= \sum_{\{\mathbf{c}^{(\gamma')}\}} \prod_{\gamma'} \oint_{|\xi_{i_{\gamma'}}^{(\gamma')}|=1} \left[\frac{d\xi^{(\gamma')}}{\xi^{(\gamma')}} \right] \frac{\left[\mathcal{I}_{\text{int}}^{(Y, \mathcal{P})}(\boldsymbol{\xi}, \mathbf{c}, \mathbf{s}^Y(\mathbf{s}_J^X), \mathbf{s}_J^Y(\mathbf{s}_{\alpha}^{(0)X}, \mathbf{s}_{\alpha}^X, \boldsymbol{\Sigma}^X); \tilde{q}, \tilde{t}^{-1}) \right]_{\substack{\tilde{w}f^{(\alpha)}=1, \\ g_{(\alpha)}=-\tilde{n}}}}{\mathcal{I}_{\text{vector}}(\tilde{q}, \tilde{t}^{-1})}. \end{aligned} \quad (\text{C.38})$$

The factor $\mathcal{I}_{\text{vector}}(\tilde{q}, \tilde{t}^{-1})$ cancels with the index of a single U(1) vector multiplet in $\mathcal{I}_{\text{int}}^{(Y, \mathcal{P})}$. Together with the conditions $\tilde{w}f^{(\alpha)}(\boldsymbol{\xi}, \mathcal{P}) = 1, g_{(\alpha)}(\mathbf{c}, \mathcal{P}) = -\tilde{n}$, this removes a single U(1) factor from the gauge group of Y . The precise U(1) being ungauged is determined by the functions $f^{(\alpha)}, g_{(\alpha)}$, or equivalently the integers $\{e^{\gamma'}(\mathcal{P})\}$. The theory $\tilde{G}_{\mathcal{P}}^{\alpha}(Y)$ is therefore a Lagrangian theory.

C.2.2 Flavoring-gauging

The Abelian flavoring-gauging operation $\mathcal{O}_{\mathcal{P}}^{\alpha}(X) = G_{\mathcal{P}}^{\alpha} \circ F_{\mathcal{P}}^{\alpha}(X)$ with $N_F^{\alpha} = 1$ can be implemented following the general expression in (C.11):

$$\mathcal{I}_{\mathcal{O}_{\mathcal{P}}^{\alpha}(X)} = \sum_{\kappa^{(\alpha)}} \oint_{|h^{(\alpha)}|=1} \left[\frac{dh^{(\alpha)}}{h^{(\alpha)}} \right] \mathcal{I}_{\mathcal{O}_{\mathcal{P}}^{\alpha}(X)}(\mathbf{s}_{\alpha}^X, \mathbf{s}_F^{\mathcal{O}}, \mathbf{s}_J^{\mathcal{O}}; \tilde{q}, \tilde{t}) \cdot \mathcal{I}^{(X, \mathcal{P})}(\mathbf{s}_{\alpha}^X, \mathbf{s}_{\alpha}^X, \boldsymbol{\Sigma}^X, \mathbf{s}_J^X; \tilde{q}, \tilde{t}), \quad (\text{C.39})$$

where the function $\mathcal{I}_{\mathcal{O}_{\mathcal{P}}^{\alpha}(X)}$ can be read off from (3.15),

$$\begin{aligned} \mathcal{I}_{\mathcal{O}_{\mathcal{P}}^{\alpha}(X)}(\mathbf{s}_{\alpha}^X, \mathbf{s}_F^{\mathcal{O}}, \mathbf{s}_J^{\mathcal{O}}; \tilde{q}, \tilde{t}) &= \mathcal{I}_{\text{FI}}(\tilde{w}, \tilde{n}, h^{(\alpha)}, \kappa^{(\alpha)}) \mathcal{I}_{\text{vector}}(\tilde{q}, \tilde{t}) \mathcal{I}_{\text{hyper}}(h^{(\alpha)}, \kappa^{(\alpha)}, \tilde{h}^{(\alpha)}, \tilde{\kappa}^{(\alpha)}; \tilde{q}, \tilde{t}) \\ &= \sum_{\kappa} \oint_{|h|=1} \frac{dh}{2\pi i h} (h^{(\alpha)})^{\kappa + \tilde{n}} (\tilde{w}h)^{\kappa^{(\alpha)}} (\tilde{h}^{(\alpha)})^{-\kappa} h^{-\tilde{\kappa}^{(\alpha)}} \mathcal{I}_{\text{hyper}}(h, \kappa, 1, 0; \tilde{q}, \tilde{t}^{-1}), \end{aligned} \quad (\text{C.40})$$

where for the second equality we have used 3d mirror symmetry between a free hyper and a $U(1)$ gauge theory with a single hypermultiplet of charge 1 (as given in the identity (B.26)). From (C.26), the function $\mathcal{I}_{\tilde{\mathcal{O}}_{\mathcal{P}}^{\alpha}(Y)}$ is given as

$$\mathcal{I}_{\tilde{\mathcal{O}}_{\mathcal{P}}^{\alpha}(Y)}(\boldsymbol{\xi}, \mathbf{c}, \mathbf{s}_F^{\mathcal{O}}, \mathbf{s}_J^{\mathcal{O}}; \tilde{q}, \tilde{t}) = \sum_{\kappa^{(\alpha)}} \oint_{|h^{(\alpha)}|=1} \left[\frac{dh^{(\alpha)}}{h^{(\alpha)}} \right] \mathcal{I}_{\mathcal{O}_{\mathcal{P}}^{\alpha}(X)}(\mathbf{s}_{\alpha}^X, \mathbf{s}_F^{\mathcal{O}}, \mathbf{s}_J^{\mathcal{O}}; \tilde{q}, \tilde{t}) \cdot \mathcal{I}_{\text{FI}}^{(0)(Y, \mathcal{P})}(\boldsymbol{\xi}, \mathbf{c}, \mathbf{s}_{\alpha}^X), \quad (\text{C.41})$$

where the function $\mathcal{I}_{\text{FI}}^{(0)(Y, \mathcal{P})}(\boldsymbol{\xi}, \mathbf{c}, \mathbf{s}_{\alpha}^X)$ is given in (C.35), (C.36) and (C.37). To simplify the above expression, we first substitute the expression for $\mathcal{I}_{\mathcal{O}_{\mathcal{P}}^{\alpha}(X)}$ from (C.40), and change the order of integration and sum between the variables $(h^{(\alpha)}, \kappa^{(\alpha)})$ and (h, κ) . Finally, implementing the integration and sum over $(h^{(\alpha)}, \kappa^{(\alpha)})$ first and then over (h, κ) (using the identities (C.30) and (C.31) respectively), we obtain

$$\mathcal{I}_{\tilde{\mathcal{O}}_{\mathcal{P}}^{\alpha}(Y)} = (\tilde{h}^{(\alpha)})^{\tilde{n}} (\tilde{w})^{\tilde{\kappa}^{(\alpha)}} (\tilde{h}^{(\alpha)})^{g_{(\alpha)}} (f^{(\alpha)})^{\tilde{\kappa}^{(\alpha)}} \mathcal{I}_{\text{hyper}}(h, \kappa, 1, 0; \tilde{q}, \tilde{t}^{-1}) \Big|_{\substack{h\tilde{w}f^{(\alpha)}=1 \\ \kappa+g_{(\alpha)}+\tilde{n}=0}}, \quad (\text{C.42})$$

where the function $\mathcal{I}_{\text{hyper}}(h, \kappa, 1, 0; \tilde{q}, \tilde{t}^{-1}) \Big|_{\substack{h\tilde{w}f^{(\alpha)}=1 \\ \kappa+g_{(\alpha)}+\tilde{n}=0}}$ denotes the index of a single hypermultiplet charged under various $U(1)$ subgroups of the gauge group of Y . The precise $U(1)$ subgroups and the respective charges are encoded in the functions $f^{(\alpha)}, g_{(\alpha)}$, or equivalently in the integers $\{e^{\gamma'}(\mathcal{P})\}$. Following the general equation (C.25), the index of the dual theory $\tilde{\mathcal{O}}_{\mathcal{P}}^{\alpha}(Y)$ is then given as

$$\begin{aligned} & \mathcal{I}_{\tilde{\mathcal{O}}_{\mathcal{P}}^{\alpha}(Y)}(\mathbf{S}(\mathbf{s}_J^X, \mathbf{s}_J^{\mathcal{O}}), \mathbf{S}_J(\mathbf{s}_{\alpha}^X, \boldsymbol{\Sigma}^X, \mathbf{s}_F^{\mathcal{O}}); \tilde{q}, \tilde{t}^{-1}) \\ &= \sum_{\{\mathbf{c}^{(\gamma')}\}} \prod_{\gamma'} \oint_{|\xi_{i, \gamma'}^{(\gamma')}|=1} \left[\frac{d\xi^{(\gamma')}}{\xi^{(\gamma')}} \right] (\tilde{h}^{(\alpha)})^{\tilde{n}} (\tilde{w})^{\tilde{\kappa}^{(\alpha)}} \mathcal{I}_{\text{hyper}}(h, \kappa, 1, 0; \tilde{q}, \tilde{t}^{-1}) \Big|_{\substack{h\tilde{w}f^{(\alpha)}=1 \\ \kappa+g_{\alpha}+\tilde{n}=0}} \\ & \times \mathcal{I}_{\text{int}}^{(Y, \mathcal{P})}(\boldsymbol{\xi}, \mathbf{c}, \mathbf{s}^Y(\mathbf{s}_J^X), \mathbf{s}_J^Y(\{h^{(\alpha)} = \tilde{h}^{(\alpha)}, \kappa^{(\alpha)} = \tilde{\kappa}^{(\alpha)}\}, \dots); \tilde{q}, \tilde{t}^{-1}). \end{aligned} \quad (\text{C.43})$$

The factor $(\tilde{h}^{(\alpha)})^{\tilde{n}} (\tilde{w})^{\tilde{\kappa}^{(\alpha)}}$ can be absorbed by redefining some of the fugacities and fluxes $(\boldsymbol{\xi}^{(\gamma')}, \mathbf{c}^{(\gamma')})$, such that $g_{(\alpha)} \rightarrow g_{(\alpha)} - \tilde{n}$, and $f^{(\alpha)} \rightarrow \frac{1}{\tilde{w}} f^{(\alpha)}$. The Lagrangian for the theory $\tilde{\mathcal{O}}_{\mathcal{P}}^{\alpha}(Y)$ can be read off from the index — it involves adding a single hypermultiplet to the quiver gauge theory Y , where the said hypermultiplet is charged under various $U(1)$ subgroups of the gauge group of Y , as noted above.

C.2.3 Identification-gauging

The Abelian identification-gauging operation $\mathcal{O}_{\mathcal{P}}^{\alpha}(X) = G_{\mathcal{P}}^{\alpha} \circ I_{\mathcal{P}}^{\alpha}(X)$ can be implemented following the general expression in (C.11):

$$\begin{aligned} \mathcal{I}_{\mathcal{O}_{\mathcal{P}}^{\alpha}(X)} &= \sum_{\kappa^{(\alpha)}} \oint_{|h^{(\alpha)}|=1} \left[\frac{dh^{(\alpha)}}{h^{(\alpha)}} \right] \mathcal{I}_{\mathcal{O}_{\mathcal{P}}^{\alpha}(X)}(\mathbf{s}_{\alpha}^X, \{\mathbf{s}_{\beta}^X\}, \mathbf{s}_F^{\mathcal{O}}, \mathbf{s}_J^{\mathcal{O}}; \tilde{q}, \tilde{t}) \\ & \times \mathcal{I}^{(X, \{\mathcal{P}_{\beta}\})}(\{\mathbf{s}_{\beta}^X, \mathbf{s}_{\beta}^{\prime X}\}, \boldsymbol{\Sigma}^X, \mathbf{s}_J^X; \tilde{q}, \tilde{t}), \end{aligned} \quad (\text{C.44})$$

where the operator $\mathcal{I}_{\mathcal{O}_{\mathcal{P}}^\alpha(X)}$ is given as (from (3.15)):

$$\mathcal{I}_{\mathcal{O}_{\mathcal{P}}^\alpha(X)} = \mathcal{I}_{\text{FI}}(\tilde{w}, \tilde{n}, h^{(\alpha)}, \kappa^{(\alpha)}) \mathcal{I}_{\text{vector}}(\tilde{q}, \tilde{t}) \prod_{\beta} \oint_{\mathcal{C}_\lambda} \frac{dh^{(\beta)}}{2\pi i (h^{(\beta)} - \lambda_\beta h^{(\alpha)})} \cdot \sum_{\{\kappa^{(\beta)}\}} \delta_{\kappa^{(\beta)}, \kappa^{(\alpha)} + \delta_\beta}. \quad (\text{C.45})$$

From (C.26), the function $\mathcal{I}_{\tilde{\mathcal{O}}_{\mathcal{P}}^\alpha(Y)}$ is given as:

$$\begin{aligned} \mathcal{I}_{\tilde{\mathcal{O}}_{\mathcal{P}}^\alpha(Y)}(\boldsymbol{\xi}, \mathbf{c}, \mathbf{s}_F^\mathcal{O}, \mathbf{s}_J^\mathcal{O}; \tilde{q}, \tilde{t}) &= \sum_{\kappa^{(\alpha)}} \oint_{|h^{(\alpha)}|=1} \left[\frac{dh^{(\alpha)}}{h^{(\alpha)}} \right] \mathcal{I}_{\mathcal{O}_{\mathcal{P}}^\alpha(X)}(\mathbf{s}_\alpha^X, \{\mathbf{s}_\beta^X\}, \mathbf{s}_F^\mathcal{O}, \mathbf{s}_J^\mathcal{O}; \tilde{q}, \tilde{t}) \\ &\times \mathcal{I}_{\text{FI}}^{(0)(Y, \{\mathcal{P}_\beta\})}(\boldsymbol{\xi}, \mathbf{c}, \{\mathbf{s}_\beta^X\}), \end{aligned} \quad (\text{C.46})$$

with the $\{h^{(\beta)}, \kappa^{(\beta)}\}$ -dependent part of the FI term of Y can be explicitly written as:

$$\mathcal{I}_{\text{FI}}^{(0)(Y, \{\mathcal{P}_\beta\})}(\boldsymbol{\xi}, \mathbf{c}, \{\mathbf{s}_\beta^X\}) = \prod_{\beta} \left[\left(f^{(\beta)}(\boldsymbol{\xi}, \mathcal{P}_\beta) \right)^{\kappa^{(\beta)}} \cdot \left(h^{(\beta)} \right)^{g_{(\beta)}(\mathbf{c}, \mathcal{P}_\beta)} \right], \quad (\text{C.47})$$

$$g_{(\beta)}(\mathbf{c}, \mathcal{P}_\beta) = \sum_{\gamma'} e^{\gamma'}(\mathcal{P}_\beta) \sum_{j_{\gamma'}} c_{j_{\gamma'}}^{(\gamma')}, \quad (\text{C.48})$$

$$f^{(\beta)}(\boldsymbol{\xi}, \mathcal{P}_\beta) = \prod_{\gamma'} \left(\prod_{j_{\gamma'}} \xi_{j_{\gamma'}}^{(\gamma')} \right)^{e^{\gamma'}(\mathcal{P}_\beta)}. \quad (\text{C.49})$$

Finally, from the general expression of (C.25), and implementing the integration over $h^{(\alpha)}$ and the sum over κ^α (using the identities (C.30) and (C.31) respectively), we obtain the index for the dual theory $\tilde{\mathcal{O}}_{\mathcal{P}}^\alpha(Y)$:

$$\begin{aligned} &\mathcal{I}_{\tilde{\mathcal{O}}_{\mathcal{P}}^\alpha(Y)}(\mathcal{S}(\mathbf{s}_J^X, \mathbf{s}_J^\mathcal{O}), \mathcal{S}_J(\{\mathbf{s}'_\beta^X\}, \mathbf{s}_F^\mathcal{O}, \boldsymbol{\Sigma}^X); \tilde{q}, \tilde{t}^{-1}) \\ &= \sum_{\{\mathbf{c}^{(\gamma')}\}} \prod_{\gamma'} \oint_{|\xi_{j_{\gamma'}}^{(\gamma')}|=1} \left[\frac{d\xi^{(\gamma')}}{\xi^{(\gamma')}} \right] \frac{\left[\mathcal{I}_{\text{int}}^{(Y, \{\mathcal{P}_\beta\})}(\boldsymbol{\xi}, \mathbf{c}, \mathbf{s}^Y(\mathbf{s}_J^X), \mathbf{s}_J^Y(\{h^{(\beta)} = \lambda_\beta, \kappa^{(\beta)} = \delta_\beta\}, \dots); \tilde{q}, \tilde{t}^{-1}) \right] \tilde{w} \prod_{\beta} f^{(\beta)} = 1, \sum_{\beta} g_\beta = -\tilde{n}}{\mathcal{I}_{\text{vector}}(\tilde{q}, \tilde{t}^{-1})}. \end{aligned} \quad (\text{C.50})$$

Similar to the case of the gauging operation, the factor $\mathcal{I}_{\text{vector}}(\tilde{q}, \tilde{t}^{-1})$ cancels with the index of a single U(1) vector multiplet in $\mathcal{I}_{\text{int}}^{(Y, \mathcal{P})}$. Together with the conditions $\tilde{w} \prod_{\beta} f^{(\beta)}(\boldsymbol{\xi}, \mathcal{P}_\beta) = 1$, $\prod_{\beta} g_{(\beta)}(\mathbf{c}, \mathcal{P}_\beta) = -\tilde{n}$, this removes a single U(1) factor from the gauge group of Y . The precise U(1) being ungauged is determined by the functions $\prod_{\beta} f^{(\beta)}$, $\sum_{\beta} g_{(\beta)}$, or equivalently the integers $\{e^{\gamma'}(\mathcal{P}_\beta)\}$. The theory $\tilde{\mathcal{O}}_{\mathcal{P}}^\alpha(Y)$ is therefore a Lagrangian theory.

C.2.4 Identification-flavoring-gauging

The Abelian identification-flavoring-gauging operation $\mathcal{O}_{\mathcal{P}}^\alpha(X) = G_{\mathcal{P}}^\alpha \circ F_{\mathcal{P}}^\alpha \circ I_{\mathcal{P}}^\alpha(X)$ can be implemented following the general expression in (C.11):

$$\begin{aligned} \mathcal{I}_{\mathcal{O}_{\mathcal{P}}^\alpha(X)} &= \sum_{\kappa^{(\alpha)}} \oint_{|h^{(\alpha)}|=1} \left[\frac{dh^{(\alpha)}}{h^{(\alpha)}} \right] \mathcal{I}_{\mathcal{O}_{\mathcal{P}}^\alpha(X)}(\mathbf{s}_\alpha^X, \{\mathbf{s}_\beta^X\}, \mathbf{s}_F^\mathcal{O}, \mathbf{s}_J^\mathcal{O}; \tilde{q}, \tilde{t}) \\ &\times \mathcal{I}^{(X, \{\mathcal{P}_\beta\})}(\{\mathbf{s}_\beta^X, \mathbf{s}'_\beta^X\}, \boldsymbol{\Sigma}^X, \mathbf{s}_J^X; \tilde{q}, \tilde{t}), \end{aligned} \quad (\text{C.51})$$

where the operator $\mathcal{I}_{\mathcal{O}_{\mathcal{P}}^\alpha(X)}$ is given as (from (3.15)):

$$\begin{aligned} \mathcal{I}_{\mathcal{O}_{\mathcal{P}}^\alpha(X)} &= \mathcal{I}_{\text{FI}}(\tilde{w}, \tilde{n}, h^{(\alpha)}, \kappa^{(\alpha)}) \mathcal{I}_{\text{vector}}(\tilde{q}, \tilde{t}) \mathcal{I}_{\text{hyper}}(h^{(\alpha)}, \kappa^{(\alpha)}, \tilde{h}^{(\alpha)}, \tilde{\kappa}^{(\alpha)}; \tilde{q}, \tilde{t}) \\ &\times \prod_{\beta} \oint_{C_{\lambda}} \frac{dh^{(\beta)}}{2\pi i (h^{(\beta)} - \lambda_{\beta} h^{(\alpha)})} \cdot \sum_{\{\kappa^{(\beta)}\}} \delta_{\kappa^{(\beta)}, \kappa^{(\alpha)} + \delta^{\beta}} \end{aligned} \quad (\text{C.52})$$

$$\begin{aligned} &= \sum_k \oint_{|h|=1} \frac{dh}{2\pi i h} (h^{(\alpha)})^{\kappa + \tilde{n}} (\tilde{w} h)^{\kappa^{(\alpha)}} (\tilde{h}^{(\alpha)})^{-\kappa} h^{-\tilde{\kappa}^{(\alpha)}} \mathcal{I}_{\text{hyper}}(h, \kappa, 1, 0; \tilde{q}, \tilde{t}^{-1}) \\ &\times \prod_{\beta} \oint_{C_{\lambda}} \frac{dh^{(\beta)}}{2\pi i (h^{(\beta)} - \lambda_{\beta} h^{(\alpha)})} \cdot \sum_{\{\kappa^{(\beta)}\}} \delta_{\kappa^{(\beta)}, \kappa^{(\alpha)} + \delta^{\beta}}, \end{aligned} \quad (\text{C.53})$$

where, for the second equality, we have used the basic 3d mirror symmetry, as given in (B.26). From (C.26), the function $\mathcal{I}_{\tilde{\mathcal{O}}_{\mathcal{P}}^\alpha(Y)}$ is given as:

$$\begin{aligned} \mathcal{I}_{\tilde{\mathcal{O}}_{\mathcal{P}}^\alpha(Y)}(\boldsymbol{\xi}, \mathbf{c}, \mathbf{s}_F^{\mathcal{O}}, \mathbf{s}_J^{\mathcal{O}}; \tilde{q}, \tilde{t}) &= \sum_{\kappa^{(\alpha)}} \oint_{|h^{(\alpha)}|=1} \left[\frac{dh^{(\alpha)}}{h^{(\alpha)}} \right] \mathcal{I}_{\mathcal{O}_{\mathcal{P}}^\alpha(X)}(\mathbf{s}_\alpha^X, \{\mathbf{s}_\beta^X\}, \mathbf{s}_F^{\mathcal{O}}, \mathbf{s}_J^{\mathcal{O}}; \tilde{q}, \tilde{t}) \\ &\times \mathcal{I}_{\text{FI}}^{(0)(Y, \{\mathcal{P}_\beta\})}(\boldsymbol{\xi}, \mathbf{c}, \{\mathbf{s}_\beta^X\}), \end{aligned} \quad (\text{C.54})$$

with $\mathcal{I}_{\text{FI}}^{(0)(Y, \{\mathcal{P}_\beta\})}$, i.e. the $\{h^{(\beta)}, \kappa^{(\beta)}\}$ -dependent part of the FI term of Y is given in (C.47), (C.48) and (C.49). The above expression can be simplified by first substituting the expression for $\mathcal{I}_{\mathcal{O}_{\mathcal{P}}^\alpha(X)}$ from (C.53), and change the order of integration and sum between the variables $(h^{(\alpha)}, \kappa^{(\alpha)})$ and (h, κ) . Finally, implementing the integration and sum over $(h^{(\alpha)}, \kappa^{(\alpha)})$ first and then over (h, κ) (using the identities (C.30) and (C.31) respectively), we obtain

$$\mathcal{I}_{\tilde{\mathcal{O}}_{\mathcal{P}}^\alpha(Y)} = (\tilde{h}^{(\alpha)})^{\tilde{n}} (\tilde{w})^{\tilde{\kappa}^{(\alpha)}} \prod_{\beta} (\tilde{h}^{(\alpha)} \lambda_{\beta})^{g(\beta)} \prod_{\beta} (f^{(\beta)})^{\delta^{\beta} + \tilde{\kappa}^{(\alpha)}} \mathcal{I}_{\text{hyper}}(h, \kappa, 1, 0; \tilde{q}, \tilde{t}^{-1}) \Big|_{\substack{h\tilde{w} \prod_{\beta} f^{(\beta)} = 1 \\ \kappa + \sum_{\beta} g(\beta) + \tilde{n} = 0}} \quad (\text{C.55})$$

where the function $\mathcal{I}_{\text{hyper}}(h, \kappa, 1, 0; \tilde{q}, \tilde{t}^{-1}) \Big|_{\substack{h\tilde{w} \prod_{\beta} f^{(\beta)} = 1 \\ \kappa + \sum_{\beta} g(\beta) + \tilde{n} = 0}}$ denotes the index of a single hypermultiplet charged under various U(1) subgroups of the gauge group of Y .

The precise U(1) subgroups and the respective charges are encoded in the functions $\prod_{\beta} f^{(\beta)}$, $\sum_{\beta} g(\beta)$, or equivalently in the integers $\{e^{\gamma'}(\mathcal{P}_\beta)\}$. Following the general equation (C.25), the index of the dual theory $\tilde{\mathcal{O}}_{\mathcal{P}}^\alpha(Y)$ is then given as

$$\begin{aligned} &\mathcal{I}_{\tilde{\mathcal{O}}_{\mathcal{P}}^\alpha(Y)}(\mathbf{S}(\mathbf{s}_J^X, \mathbf{s}_J^{\mathcal{O}}), \mathbf{S}_J(\{\mathbf{s}_\beta^X\}, \mathbf{s}_F^{\mathcal{O}}, \boldsymbol{\Sigma}^X); \tilde{q}, \tilde{t}^{-1}) \\ &= \sum_{\{e^{(\gamma')}\}} \prod_{\gamma'} \oint_{|\xi_{i, \gamma'}^{(\gamma')}|=1} \left[\frac{d\xi^{(\gamma')}}{\xi^{(\gamma')}} \right] (\tilde{h}^{(\alpha)})^{\tilde{n}} (\tilde{w})^{\tilde{\kappa}^{(\alpha)}} \mathcal{I}_{\text{hyper}}(h, \kappa, 1, 0; \tilde{q}, \tilde{t}^{-1}) \Big|_{\substack{h\tilde{w} \prod_{\beta} f^{(\beta)} = 1 \\ \kappa + \sum_{\beta} g(\beta) + \tilde{n} = 0}} \\ &\times \mathcal{I}_{\text{int}}^{(Y, \{\mathcal{P}_\beta\})}(\boldsymbol{\xi}, \mathbf{c}, \mathbf{s}_J^Y(\mathbf{s}_J^X), \mathbf{s}_J^Y(\{h^{(\beta)} = \tilde{h}^{(\alpha)} \lambda_{\beta}, \kappa^{(\beta)} = \delta^{\beta} + \tilde{\kappa}^{(\alpha)}\}, \dots); \tilde{q}, \tilde{t}^{-1}). \end{aligned} \quad (\text{C.56})$$

As mentioned in our discussion on (C.14), one has the freedom to choose $\lambda_{\beta'} = 1$, $\delta_{\beta'} = 0$, for some $\beta' \in \{\gamma_1, \gamma_2, \dots, \gamma_p\}$. Redefining some of the fugacities and fluxes $(\boldsymbol{\xi}^{(\gamma')}, \mathbf{c}^{(\gamma')})$,

such that $g_{(\beta')} \rightarrow g_{(\beta')} - \tilde{n}$, and $f^{(\beta')} \rightarrow \frac{1}{\tilde{w}} f^{(\beta')}$, the factor $(\tilde{h}^{(\alpha)})^{\tilde{n}} (\tilde{w})^{\tilde{\kappa}^{(\alpha)}}$ can be absorbed in the integrand. The Lagrangian for the theory $\tilde{\mathcal{O}}_{\mathcal{P}}^{\alpha}(Y)$ can be read off from the index — it involves adding a single hypermultiplet to the quiver gauge theory Y , where the said hypermultiplet is charged under various $U(1)$ subgroups of the gauge group of Y , as noted above.

C.3 Sample computation: flavored \hat{A}_{n-1} quiver and family $I_{[n,l,p]}$

In this section, we will demonstrate concrete examples of how an elementary S -type operation and its dual may be implemented in terms of the superconformal index, to construct new pairs of dual theories. We first work out the example of a flavored \hat{A}_{n-1} quiver (discussed in section 3.4 in terms of the S^3 partition function), followed by the Family $I_{[n,l,p]}$ (discussed in section 4.2.1). The quiver operation is shown in figure 45. The indices of the dual theories can be simply read off from the general expressions (C.56) (identification-flavoring-gauging) and (C.43) (flavoring-gauging) respectively, but we work out the first example in details to familiarize the reader with the computation.

Given the dual linear quiver pair (X, Y) , their superconformal indices can be read off from the general expressions (B.17) and (B.28) respectively. The Higgs branch global symmetry for X is $G_H^X = U(1)^3/U(1)$, where we choose to impose the $U(1)$ quotient such that $G_H^X = U(1)_1 \times U(1)_{n-1}$. The fugacities and GNO fluxes $\{h^\beta, \kappa^\beta\}$ for G_H^X are then defined as:

$$\tilde{z}_1 = h^1, \quad \tilde{z}_2 = 1, \quad \tilde{z}_3 = h^2, \quad (\text{C.57})$$

$$\tilde{a}_1 = \kappa^1, \quad \tilde{a}_2 = 0, \quad \tilde{a}_3 = \kappa^2, \quad (\text{C.58})$$

where the fugacities \tilde{z} and the fluxes \tilde{a} for a linear quiver are defined in (B.14) and in (B.15) respectively. Using the above choice, the FI term in the SCI of the quiver Y , following (B.29), is given as

$$\mathcal{I}_{\text{FI}}^{(Y)}(\tilde{z}, \tilde{a}, \{\xi^{(\gamma')}\}, \{c^{(\gamma')}\}) = \prod_{i=1}^2 \left(\frac{\tilde{z}_i}{\tilde{z}_{i+1}} \right)^{c^i} \cdot (\xi^i)^{\tilde{a}_i - \tilde{a}_{i+1}} = (h^1)^{c^1} (\xi^1)^{\kappa^1} (h^2)^{-c^2} (\xi^2)^{-\kappa^2}. \quad (\text{C.59})$$

Now, let us implement an identification-flavoring-gauging operation \mathcal{O}_1 at the $U(1)_1 \times U(1)_{n-1}$ flavor nodes of X . The superconformal index of the resultant theory $\mathcal{O}_1(X)$ is given by (C.11), i.e.

$$\mathcal{I}^{\mathcal{O}_1(X)} = \sum_{\kappa^{(\alpha)}} \oint_{|h^{(\alpha)}|=1} \frac{dh^{(\alpha)}}{2\pi i h^{(\alpha)}} \mathcal{S}_{\mathcal{O}_1(X)}(s_\alpha^X, \{s_\beta^X\}, \mathbf{s}_F^{\mathcal{O}_1}, \mathbf{s}_J^{\mathcal{O}_1}; \tilde{q}, \tilde{t}) \cdot \mathcal{I}^{(X)}(s_\beta^X, \mathbf{s}_J^X; \tilde{q}, \tilde{t}), \quad (\text{C.60})$$

where $\mathcal{I}^{(X)}$ is given by (B.17). The operator $\mathcal{S}_{\mathcal{O}_1(X)}$, corresponding to an Abelian identification-flavoring-gauging operation with $N_F^\alpha = 1$, can be constructed from (C.12)–(C.14) and (C.16) as follows:

$$\begin{aligned} \mathcal{S}_{\mathcal{O}_1(X)} &= \mathcal{I}_{\text{FI}}(\tilde{w}, \tilde{n}, h^{(\alpha)}, \kappa^{(\alpha)}) \mathcal{I}_{\text{vector}}(h^{(\alpha)}, \kappa^{(\alpha)}; \tilde{q}, \tilde{t}) \mathcal{I}_{\text{hyper}}(h^{(\alpha)}, \kappa^{(\alpha)}, \tilde{h}^{(\alpha)}, \tilde{\kappa}^{(\alpha)}; \tilde{q}, \tilde{t}) \\ &\times \prod_{\beta=1}^2 \oint_{C_\lambda} \frac{dh^\beta}{2\pi i (h^\beta - \lambda_\beta h^{(\alpha)})} \cdot \sum_{\{\kappa^\beta\}} \prod_{\beta=1}^2 \delta_{\kappa^\beta, \kappa^{(\alpha)} + \delta^\beta}. \end{aligned} \quad (\text{C.61})$$

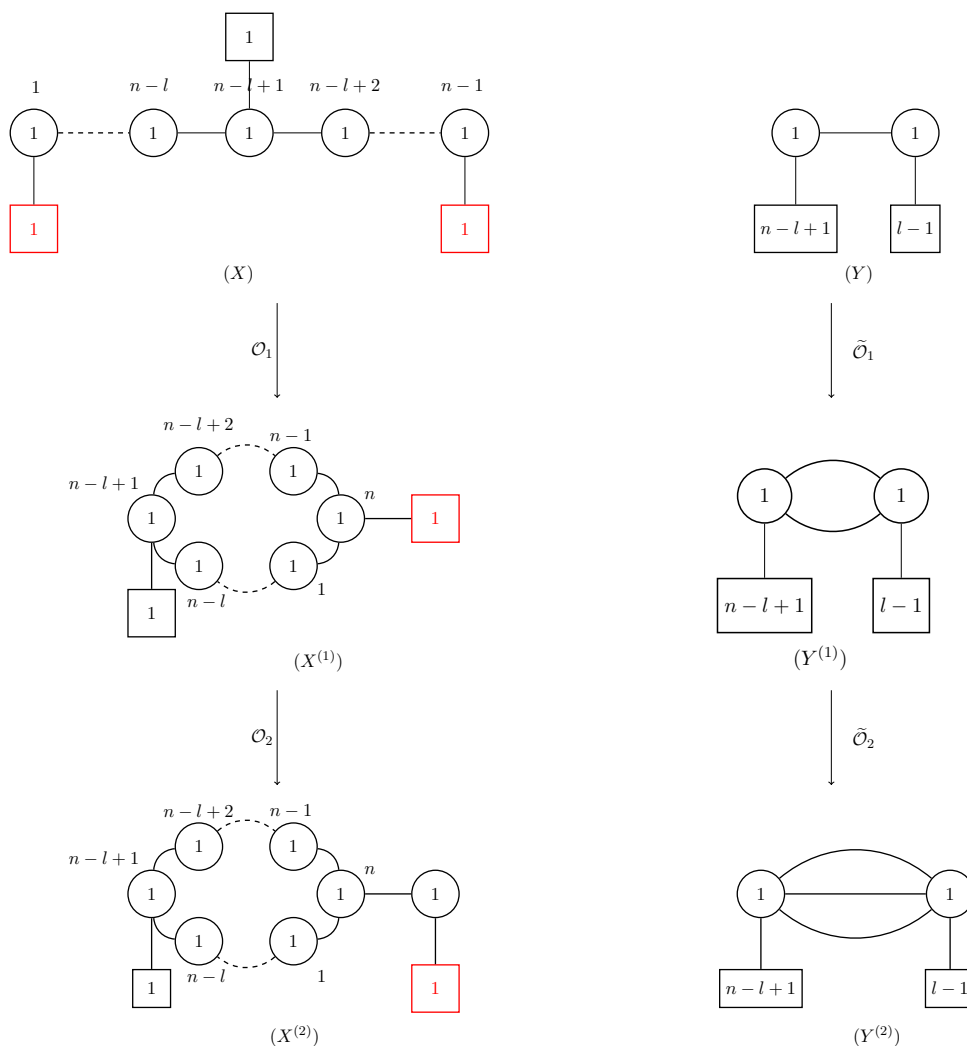

Figure 45. The quiver (X') and its mirror dual (Y') in figure 17 (for $p = 3$) is generated by a sequence of elementary S -type operations on different nodes. In each step, the flavor node(s) on which the S -type operation acts is shown in red. The intermediate step involves a flavored \hat{A}_{n-1} quiver and its dual.

We will eventually set $\lambda_1 = 1$, $\delta_1 = 0$, which can be chosen by an appropriate reparametrization of $h^{(\alpha)}$. The FI term and the vector multiplet contribution for a $U(1)$ gauge group can be read off from (B.8)–(B.9):

$$\mathcal{I}_{\text{FI}}(\tilde{w}, \tilde{n}, h^{(\alpha)}, \kappa^{(\alpha)}) = \tilde{w}^{\kappa^{(\alpha)}} (h^{(\alpha)})^{\tilde{n}}, \tag{C.62}$$

$$\mathcal{I}_{\text{vector}}(\mathbf{h}^{(\alpha)}, \boldsymbol{\kappa}^{(\alpha)}; \tilde{q}, \tilde{t}) = \mathcal{I}_{\text{vector}}(\tilde{q}, \tilde{t}) = \left(\frac{(\tilde{t}\tilde{q}^{1/2}; \tilde{q})}{(\tilde{t}^{-1}\tilde{q}^{1/2}; \tilde{q})} \right). \tag{C.63}$$

The contribution of the single free hypermultiplet, given by (B.10), obeys the identity:

$$\mathcal{I}_{\text{hyper}}(h^{(\alpha)}, \kappa^{(\alpha)}, \tilde{h}^{(\alpha)}, \tilde{\kappa}^{(\alpha)}; \tilde{q}, \tilde{t}) = \left(\frac{\tilde{q}^{1/2}}{\tilde{t}} \right)^{|\kappa^{(\alpha)} - \tilde{\kappa}^{(\alpha)}|/2} \frac{(\tilde{t}^{-1/2} \tilde{q}^{3/4 + |\kappa^{(\alpha)} - \tilde{\kappa}^{(\alpha)}|/2} (\frac{h^{(\alpha)}}{\tilde{h}^{(\alpha)}})^{\pm 1}; \tilde{q})}{(\tilde{t}^{1/2} \tilde{q}^{1/4 + |\kappa^{(\alpha)} - \tilde{\kappa}^{(\alpha)}|/2} (\frac{h^{(\alpha)}}{\tilde{h}^{(\alpha)}})^{\pm 1}; \tilde{q})} \quad (\text{C.64})$$

$$= \sum_{\kappa} \oint_{|h|=1} \frac{dh}{2\pi i h} \left(\frac{h^{(\alpha)}}{\tilde{h}^{(\alpha)}} \right)^{\kappa} h^{(\kappa^{(\alpha)} - \tilde{\kappa}^{(\alpha)})} \mathcal{I}_{\text{vector}}(h, \kappa; \tilde{q}, \tilde{t}^{-1}) \mathcal{I}_{\text{hyper}}(h, \kappa, 1, 0; \tilde{q}, \tilde{t}^{-1}) \quad (\text{C.65})$$

$$= \sum_{\kappa} \oint_{|h|=1} \frac{dh}{2\pi i h} \left(\frac{h^{(\alpha)}}{\tilde{h}^{(\alpha)}} \right)^{\kappa} h^{(\kappa^{(\alpha)} - \tilde{\kappa}^{(\alpha)})} \mathcal{I}_{\text{vector}}(\tilde{q}, \tilde{t}^{-1}) \mathcal{I}_{\text{hyper}}(h, \kappa, 1, 0; \tilde{q}, \tilde{t}^{-1}), \quad (\text{C.66})$$

where for the second equality we have used the 3d mirror symmetry relation (B.26) between a single twisted hypermultiplet and a U(1) gauge theory with a single hypermultiplet.

Given the operator $\mathcal{S}_{\mathcal{O}_1(X)}$ in (C.61), the SCI of the dual theory $\tilde{\mathcal{O}}_1(Y)$ can be computed using (C.19)–(C.20). Let us first compute the function $\mathcal{S}_{\tilde{\mathcal{O}}_1(Y)}(\boldsymbol{\xi}, \mathbf{c}, \mathbf{s}_F^{\mathcal{O}_1}, \mathbf{s}_J^{\mathcal{O}_1}; \tilde{q}, \tilde{t})$ using (C.20), which gives:

$$\mathcal{S}_{\tilde{\mathcal{O}}_1(Y)} = \sum_{\kappa^{(\alpha)}} \oint_{|h^{(\alpha)}|=1} \frac{dh^{(\alpha)}}{2\pi i h^{(\alpha)}} \mathcal{S}_{\mathcal{O}_1(X)}(\mathbf{s}_\alpha, \{\mathbf{s}_\beta\}, \mathbf{s}_F^{\mathcal{O}_1}, \mathbf{s}_J^{\mathcal{O}_1}; \tilde{q}, \tilde{t}) \mathcal{I}_{\text{FI}}^{(0)(Y)}(\boldsymbol{\xi}, \mathbf{c}, \{\mathbf{s}_\beta\}), \quad (\text{C.67})$$

$$\mathcal{I}_{\text{FI}}^{(0)(Y)}(\boldsymbol{\xi}, \mathbf{c}, \{\mathbf{s}_\beta\}) = (h^1)^{c^1} (\xi^1)^{\kappa^1} (h^2)^{-c^2} (\xi^2)^{-\kappa^2}, \quad (\text{C.68})$$

where we have read off $\{h^\beta, \kappa^\beta\}$ -dependent $\mathcal{I}_{\text{FI}}^{(0)(Y)}$ from (C.59). Using (C.62), (C.63), and (C.66), and interchanging the order of integration and sum over fluxes, we get

$$\begin{aligned} \mathcal{S}_{\tilde{\mathcal{O}}_1(Y)} &= \sum_{\kappa} \oint_{|h|=1} \frac{dh}{2\pi i h} \left(\sum_{\kappa^{(\alpha)}} \left(\frac{\tilde{w} h \xi^1}{\xi^2} \right)^{\kappa^{(\alpha)}} \right) \oint_{|h^{(\alpha)}|=1} \frac{dh^{(\alpha)}}{2\pi i h^{(\alpha)}} (h^{(\alpha)})^{c^1 - c^2 + \kappa + \tilde{n}} \\ &\quad \times (h^{-\tilde{k}^\alpha} (\tilde{h}^{(\alpha)})^{-\kappa} \lambda_1^{c^1} \lambda_2^{-c^2} (\xi^1)^{\delta_1} (\xi^2)^{-\delta_2}) \mathcal{I}_{\text{hyper}}(h, \kappa, 1, 0; \tilde{q}, \tilde{t}^{-1}). \end{aligned} \quad (\text{C.69})$$

Using the identities,

$$\oint_{|h^{(\alpha)}|=1} \frac{dh^{(\alpha)}}{2\pi i h^{(\alpha)}} (h^{(\alpha)})^{c^1 - c^2 + \kappa + \tilde{n}} = \delta_{c^1 - c^2 + \kappa + \tilde{n}, 0}, \quad (\text{C.70})$$

$$\oint_{|h|=1} \frac{dh}{2\pi i h} \left(\sum_{\kappa^{(\alpha)}} \left(\frac{\tilde{w} h \xi^1}{\xi^2} \right)^{\kappa^{(\alpha)}} \right) F(h, \kappa) = F\left(\frac{\xi^2}{\xi^1 \tilde{w}}, \kappa \right), \quad (\text{C.71})$$

we have the following expression

$$\mathcal{S}_{\tilde{\mathcal{O}}_1(Y)} = (\tilde{h}^{(\alpha)})^{c^1 - c^2 + \tilde{n}} (\lambda_1^{c^1} \lambda_2^{-c^2} (\xi^1)^{\delta_1} (\xi^2)^{-\delta_2}) \left(\frac{\xi^2}{\xi^1 \tilde{w}} \right)^{-\tilde{k}^\alpha} \mathcal{I}_{\text{hyper}}\left(\frac{\xi^2}{\xi^1 \tilde{w}}, -c^1 + c^2 - \tilde{n}, 1, 0; \tilde{q}, \tilde{t}^{-1} \right) \quad (\text{C.72})$$

$$= (\tilde{h}^{(\alpha)})^{c^1 + \tilde{n}} (\tilde{h}^{(\alpha)} \lambda)^{-c^2} (\xi^1 \tilde{w})^{\tilde{k}^\alpha} (\xi^2)^{-\tilde{k}^\alpha - \delta} \mathcal{I}_{\text{hyper}}^{\text{bif}}(\xi^2, c^2, \xi^1 \tilde{w}, c^1 + \tilde{n}; \tilde{q}, \tilde{t}^{-1}), \quad (\text{C.73})$$

where for the second equality, we have set $\lambda_1 = 1, \delta_1 = 0$, as mentioned earlier, and $\lambda_2 = \lambda, \delta_1 = \delta$. We also identify the hypermultiplet term as the 1-loop contribution of a bifundamental hypermultiplet, with fugacities and fluxes as shown in the argument of

$\mathcal{I}_{\text{hyper}}^{\text{bif}}$. The index of the dual theory is then given by:

$$\begin{aligned} \mathcal{I}^{\tilde{\mathcal{O}}_1(Y)} &= \sum_{c^1, c^2} \oint_{|\xi^i|=1} \prod_{i=1}^2 \left[\frac{d\xi^i}{2\pi i \xi^i} \right] \mathcal{I}_{\text{hyper}}^{\text{bif}}(\xi^2, c^2, \xi^1, c^1; \tilde{q}, \tilde{t}^{-1}) \cdot \mathcal{I}_{\text{FI}}^{(Y)}(\boldsymbol{\xi}, \mathbf{c}, \tilde{\mathbf{z}}(\tilde{h}^{(\alpha)}, \lambda), \tilde{\mathbf{a}}(\tilde{k}^\alpha, \delta)) \\ &\times \left[\mathcal{I}_{1\text{-loop}}^{(Y)}(\boldsymbol{\xi}, \mathbf{c}, \mathbf{s}_J^X; \tilde{q}, \tilde{t}^{-1}) \right]_{\xi^1 \rightarrow \xi^1/\tilde{w}, c^1 \rightarrow c^1 - \tilde{n}}, \end{aligned} \quad (\text{C.74})$$

where we have performed the change of variables $\xi^1 \rightarrow \xi^1/\tilde{w}$, $c^1 \rightarrow c^1 - \tilde{n}$. The fugacities and fluxes $(\tilde{\mathbf{z}}, \tilde{\mathbf{a}})$ are explicitly given as

$$\tilde{z}_1 = \tilde{h}^{(\alpha)}, \quad \tilde{z}_2 = 1, \quad \tilde{z}_3 = \tilde{h}^{(\alpha)} \lambda, \quad (\text{C.75})$$

$$\tilde{a}_1 = \tilde{k}^\alpha, \quad \tilde{a}_2 = 0, \quad \tilde{a}_3 = \tilde{k}^\alpha + \delta. \quad (\text{C.76})$$

The dual theory $\tilde{\mathcal{O}}_1(Y)$ can now be read off from the r.h.s. of the expression (C.74) for the index, and manifestly reproduce the quiver $Y^{(1)}$ above. Note that, we could have directly arrived at the result (C.74) from the general expression for an identification-flavoring-gauging operation in (C.56), with the input (C.59).

As discussed in section B, the Higgs branch and the Coulomb branch global symmetries for $(X^{(1)}, Y^{(1)})$ can be read off from the respective limits of the index. In particular, we would like to point out that the Coulomb branch symmetry for $X^{(1)}$ is $G_{\text{C}}^{X^{(1)}} = G_{\text{H}}^{Y^{(1)}} = \text{U}(1) \times \text{SU}(n-l+1) \times \text{SU}(l-1) \times \text{SU}(2)$. The $\text{SU}(n-l+1) \times \text{SU}(l-1)$ subgroup of $G_{\text{C}}^{X^{(1)}}$ is manifest from the balanced linear subquivers inside of $X^{(1)}$, but the remaining $\text{U}(1)_{n-l+1} \times \text{U}(1)_n$ gets enhanced to $\text{U}(1) \times \text{SU}(2)$. This can be directly seen from the Coulomb branch index/ Hilbert Series of $X^{(1)}$. Let us compute the refined index for the theory labelled by $n=6, l=4$. The global symmetry in this case is $G_{\text{C}}^{X^{(1)}} = \text{U}(1) \times \text{SU}(3)_1 \times \text{SU}(3)_2 \times \text{SU}(2)$. With $\tilde{x} = t^2$, the character expansion of the Coulomb branch Hilbert Series is given as:

$$\mathcal{I}_{\text{C}}^{(X^{(1)})} = 1 + ([1, 1]_1 + [1, 1]_2 + [2] + 1)t^2 + ([1, 0]_1 [0, 1]_2 [1] + [0, 1]_1 [1, 0]_2 [1])t^3 + \dots, \quad (\text{C.77})$$

where $[m, n]_i$ denotes the character of the representation with Dynkin labels $[m, n]$ for $\text{SU}(3)_i$, and $[l]$ denotes the spin- $l/2$ representation of $\text{SU}(2)$.

Now let us implement the flavoring-gauging operation \mathcal{O}_2 on the quiver gauge theory $X^{(1)}$ at the flavor node shown in red in figure 45. The fugacity and flux associated with this node is $(\tilde{h}^{(\alpha)}, \tilde{k}^{(\alpha)})$. Following the notation of appendix C.1, we will label this node as (α) , and set

$$h^{(\alpha)} = \tilde{h}^{(\alpha)}, \quad k^{(\alpha)} = \tilde{k}^{(\alpha)}. \quad (\text{C.78})$$

From (C.74), the FI-term contribution to the index of $Y^{(1)}$ is given as

$$\begin{aligned} \mathcal{I}_{\text{FI}}^{(Y^{(1)})}(\boldsymbol{\xi}, \mathbf{c}, \tilde{\mathbf{z}}(\tilde{h}^{(\alpha)}, \lambda), \tilde{\mathbf{a}}(\tilde{k}^\alpha, \delta)) &= (\tilde{h}^{(\alpha)})^{c^1} (\tilde{h}^{(\alpha)} \lambda)^{-c^2} (\xi^1)^{\tilde{k}^{(\alpha)}} (\xi^2)^{-\tilde{k}^\alpha - \delta} \\ &= (h^{(\alpha)})^{c^1 - c^2} \left(\frac{\xi_1}{\xi_2} \right)^{k^{(\alpha)}} \lambda^{-c^2} (\xi^2)^{-\delta}, \end{aligned} \quad (\text{C.79})$$

which implies that the $(h^{(\alpha)}, \kappa^{(\alpha)})$ -dependent part of the FI term for the theory $Y^{(1)}$ is

$$\mathcal{I}_{\text{FI}}^{(0)(Y^{(1)})} = (h^{(\alpha)})^{c^1 - c^2} \left(\frac{\xi_1}{\xi_2} \right)^{k^{(\alpha)}}. \quad (\text{C.80})$$

In addition, we parametrize the $U(1)$ flavor fugacity/flux and the $U(1)_J$ topological fugacity/flux associated with the S -type operation \mathcal{O}_2 as follows:

$$s_F^{\mathcal{O}_2} = (\tilde{h}'^{(\alpha)}, \tilde{k}'^{(\alpha)}), \quad s_J^{\mathcal{O}_2} = (\tilde{w}', \tilde{n}'). \quad (\text{C.81})$$

The index for the dual theory $\tilde{\mathcal{O}}_2(Y^{(1)})$ can then be read off from the general expression (C.43) as follows:

$$\begin{aligned} \mathcal{I}^{\tilde{\mathcal{O}}_2(Y^{(1)})} = & \sum_{c^1, c^2} \oint_{|\xi^i|=1} \prod_{i=1}^2 \left[\frac{d\xi^i}{2\pi i \xi^i} \right] \mathcal{I}_{\text{hyper}}^{\text{bif}}(\xi^2, c^2, \xi^1, c^1; \tilde{q}, \tilde{t}^{-1}) \mathcal{I}_{\text{hyper}}^{\text{bif}}\left(\xi^2, c^2, \frac{\xi^1}{\tilde{w}'}, c^1 - \tilde{n}'; \tilde{q}, \tilde{t}^{-1}\right) \\ & \times \mathcal{I}_{\text{FI}}^{(Y)}(\xi, \mathbf{c}, \tilde{z}(\tilde{h}'^{(\alpha)}, \lambda), \tilde{\mathbf{a}}(\tilde{k}'^{(\alpha)}, \delta)) \cdot \left[\mathcal{I}_{1\text{-loop}}^{(Y)}(\xi, \mathbf{c}, \mathbf{s}_J^X; \tilde{q}, \tilde{t}^{-1}) \right]_{\xi^1 \rightarrow \xi^1/(\tilde{w}\tilde{w}'), c^1 \rightarrow c^1 - \tilde{n} - \tilde{n}'} \end{aligned} \quad (\text{C.82})$$

The Lagrangian for the dual theory $\tilde{\mathcal{O}}_2(Y^{(1)})$ can be read from the above index — it involves adding two hypermultiplets in the bifundamental representation of the $U(1) \times U(1)$ gauge group to the quiver Y , and is therefore given by the quiver gauge theory $Y^{(2)}$ in figure 45. The fugacities and fluxes $(\tilde{z}, \tilde{\mathbf{a}})$ are explicitly given as

$$\tilde{z}_1 = \tilde{h}'^{(\alpha)}, \quad \tilde{z}_2 = 1, \quad \tilde{z}_3 = \tilde{h}'^{(\alpha)} \lambda, \quad (\text{C.83})$$

$$\tilde{\mathbf{a}}_1 = \tilde{k}'^{(\alpha)}, \quad \tilde{\mathbf{a}}_2 = 0, \quad \tilde{\mathbf{a}}_3 = \tilde{k}'^{(\alpha)} + \delta. \quad (\text{C.84})$$

Implementing a sequence of flavoring-gauging operations at the new flavor node generates the infinite family of dual theories in $I_{[n,l,p]}$, as discussed in section 4.2.1 in terms of the sphere partition function.

Open Access. This article is distributed under the terms of the Creative Commons Attribution License ([CC-BY 4.0](https://creativecommons.org/licenses/by/4.0/)), which permits any use, distribution and reproduction in any medium, provided the original author(s) and source are credited.

References

- [1] V. Pestun et al., *Localization techniques in quantum field theories*, *J. Phys. A* **50** (2017) 440301 [[arXiv:1608.02952](https://arxiv.org/abs/1608.02952)] [[INSPIRE](https://inspirehep.net/literature/1608029)].
- [2] G. Festuccia and N. Seiberg, *Rigid supersymmetric theories in curved superspace*, *JHEP* **06** (2011) 114 [[arXiv:1105.0689](https://arxiv.org/abs/1105.0689)] [[INSPIRE](https://inspirehep.net/literature/1105068)].
- [3] E. Witten, *SL(2, Z) action on three-dimensional conformal field theories with Abelian symmetry*, in *From fields to strings: circumnavigating theoretical physics. A conference in tribute to Ian Kogan*, (2003) [[hep-th/0307041](https://arxiv.org/abs/hep-th/0307041)] [[INSPIRE](https://inspirehep.net/literature/1000000)].
- [4] K.A. Intriligator and N. Seiberg, *Mirror symmetry in three-dimensional gauge theories*, *Phys. Lett. B* **387** (1996) 513 [[hep-th/9607207](https://arxiv.org/abs/hep-th/9607207)] [[INSPIRE](https://inspirehep.net/literature/1400000)].
- [5] J. de Boer, K. Hori, H. Ooguri, Y. Oz and Z. Yin, *Mirror symmetry in three-dimensional theories, SL(2, Z) and D-brane moduli spaces*, *Nucl. Phys. B* **493** (1997) 148 [[hep-th/9612131](https://arxiv.org/abs/hep-th/9612131)] [[INSPIRE](https://inspirehep.net/literature/1400000)].
- [6] J. de Boer, K. Hori, H. Ooguri and Y. Oz, *Mirror symmetry in three-dimensional gauge theories, quivers and D-branes*, *Nucl. Phys. B* **493** (1997) 101 [[hep-th/9611063](https://arxiv.org/abs/hep-th/9611063)] [[INSPIRE](https://inspirehep.net/literature/1400000)].

- [7] A. Kapustin and M.J. Strassler, *On mirror symmetry in three-dimensional Abelian gauge theories*, *JHEP* **04** (1999) 021 [[hep-th/9902033](#)] [[INSPIRE](#)].
- [8] S. Sachdev and X. Yin, *Deconfined criticality and supersymmetry*, [arXiv:0808.0191](#) [[INSPIRE](#)].
- [9] J. Murugan and H. Nastase, *Particle-vortex duality in topological insulators and superconductors*, *JHEP* **05** (2017) 159 [[arXiv:1606.01912](#)] [[INSPIRE](#)].
- [10] N. Seiberg, T. Senthil, C. Wang and E. Witten, *A duality web in 2 + 1 dimensions and condensed matter physics*, *Annals Phys.* **374** (2016) 395 [[arXiv:1606.01989](#)] [[INSPIRE](#)].
- [11] S. Giombi, S. Minwalla, S. Prakash, S.P. Trivedi, S.R. Wadia and X. Yin, *Chern-Simons theory with vector fermion matter*, *Eur. Phys. J. C* **72** (2012) 2112 [[arXiv:1110.4386](#)] [[INSPIRE](#)].
- [12] O. Aharony, G. Gur-Ari and R. Yacoby, *Correlation functions of large N Chern-Simons-matter theories and bosonization in three dimensions*, *JHEP* **12** (2012) 028 [[arXiv:1207.4593](#)] [[INSPIRE](#)].
- [13] O. Aharony, *Baryons, monopoles and dualities in Chern-Simons-matter theories*, *JHEP* **02** (2016) 093 [[arXiv:1512.00161](#)] [[INSPIRE](#)].
- [14] A. Karch and D. Tong, *Particle-vortex duality from 3d bosonization*, *Phys. Rev. X* **6** (2016) 031043 [[arXiv:1606.01893](#)] [[INSPIRE](#)].
- [15] S. Kachru, M. Mulligan, G. Torroba and H. Wang, *Bosonization and mirror symmetry*, *Phys. Rev. D* **94** (2016) 085009 [[arXiv:1608.05077](#)] [[INSPIRE](#)].
- [16] S. Kachru, M. Mulligan, G. Torroba and H. Wang, *Nonsupersymmetric dualities from mirror symmetry*, *Phys. Rev. Lett.* **118** (2017) 011602 [[arXiv:1609.02149](#)] [[INSPIRE](#)].
- [17] A. Dey, *On three-dimensional mirror symmetry*, *JHEP* **04** (2012) 051 [[arXiv:1109.0407](#)] [[INSPIRE](#)].
- [18] A. Dey and J. Distler, *Three dimensional mirror symmetry and partition function on S^3* , *JHEP* **10** (2013) 086 [[arXiv:1301.1731](#)] [[INSPIRE](#)].
- [19] A. Dey, A. Hanany, P. Koroteev and N. Mekareeya, *Mirror symmetry in three dimensions via gauged linear quivers*, *JHEP* **06** (2014) 059 [[arXiv:1402.0016](#)] [[INSPIRE](#)].
- [20] M. Dedushenko, S.S. Pufu and R. Yacoby, *A one-dimensional theory for Higgs branch operators*, *JHEP* **03** (2018) 138 [[arXiv:1610.00740](#)] [[INSPIRE](#)].
- [21] M. Dedushenko, Y. Fan, S.S. Pufu and R. Yacoby, *Coulomb branch operators and mirror symmetry in three dimensions*, *JHEP* **04** (2018) 037 [[arXiv:1712.09384](#)] [[INSPIRE](#)].
- [22] M. Dedushenko, Y. Fan, S.S. Pufu and R. Yacoby, *Coulomb branch quantization and abelianized monopole bubbling*, *JHEP* **10** (2019) 179 [[arXiv:1812.08788](#)] [[INSPIRE](#)].
- [23] Y. Fan and Y. Wang, *Non-Abelian mirror symmetry beyond the chiral ring*, *Phys. Rev. D* **101** (2020) 085008 [[arXiv:1912.05108](#)] [[INSPIRE](#)].
- [24] A. Hanany and E. Witten, *Type IIB superstrings, BPS monopoles, and three-dimensional gauge dynamics*, *Nucl. Phys. B* **492** (1997) 152 [[hep-th/9611230](#)] [[INSPIRE](#)].
- [25] A. Hanany and A. Zaffaroni, *Issues on orientifolds: on the brane construction of gauge theories with $SO(2N)$ global symmetry*, *JHEP* **07** (1999) 009 [[hep-th/9903242](#)] [[INSPIRE](#)].

- [26] D. Gaiotto and E. Witten, *Supersymmetric boundary conditions in $N = 4$ super Yang-Mills theory*, *J. Statist. Phys.* **135** (2009) 789 [[arXiv:0804.2902](#)] [[INSPIRE](#)].
- [27] D. Gaiotto and E. Witten, *S-duality of boundary conditions in $N = 4$ super Yang-Mills theory*, *Adv. Theor. Math. Phys.* **13** (2009) 721 [[arXiv:0807.3720](#)] [[INSPIRE](#)].
- [28] M. Porrati and A. Zaffaroni, *M theory origin of mirror symmetry in three-dimensional gauge theories*, *Nucl. Phys. B* **490** (1997) 107 [[hep-th/9611201](#)] [[INSPIRE](#)].
- [29] E. Witten, *Branes, instantons, and Taub-NUT spaces*, *JHEP* **06** (2009) 067 [[arXiv:0902.0948](#)] [[INSPIRE](#)].
- [30] F. Benini, Y. Tachikawa and D. Xie, *Mirrors of 3d Sicilian theories*, *JHEP* **09** (2010) 063 [[arXiv:1007.0992](#)] [[INSPIRE](#)].
- [31] D. Xie, *General Argyres-Douglas theory*, *JHEP* **01** (2013) 100 [[arXiv:1204.2270](#)] [[INSPIRE](#)].
- [32] A. Kapustin, B. Willett and I. Yaakov, *Exact results for Wilson loops in superconformal Chern-Simons theories with matter*, *JHEP* **03** (2010) 089 [[arXiv:0909.4559](#)] [[INSPIRE](#)].
- [33] A. Kapustin, B. Willett and I. Yaakov, *Nonperturbative tests of three-dimensional dualities*, *JHEP* **10** (2010) 013 [[arXiv:1003.5694](#)] [[INSPIRE](#)].
- [34] Y. Imamura and S. Yokoyama, *Index for three dimensional superconformal field theories with general R-charge assignments*, *JHEP* **04** (2011) 007 [[arXiv:1101.0557](#)] [[INSPIRE](#)].
- [35] A. Kapustin and B. Willett, *Generalized superconformal index for three dimensional field theories*, [arXiv:1106.2484](#) [[INSPIRE](#)].
- [36] F. Benini, T. Nishioka and M. Yamazaki, *4d index to 3d index and 2d TQFT*, *Phys. Rev. D* **86** (2012) 065015 [[arXiv:1109.0283](#)] [[INSPIRE](#)].
- [37] P. Boalch, *Irregular connections and Kac-Moody root systems*, [arXiv:0806.1050](#).
- [38] K. Maruyoshi and J. Song, *Enhancement of supersymmetry via renormalization group flow and the superconformal index*, *Phys. Rev. Lett.* **118** (2017) 151602 [[arXiv:1606.05632](#)] [[INSPIRE](#)].
- [39] D. Gaiotto, G.W. Moore and A. Neitzke, *Wall-crossing, Hitchin systems, and the WKB approximation*, [arXiv:0907.3987](#) [[INSPIRE](#)].
- [40] S. Cecotti, A. Neitzke and C. Vafa, *R-twisting and 4d/2d correspondences*, [arXiv:1006.3435](#) [[INSPIRE](#)].
- [41] A. Dey, *Line defects in three dimensional mirror symmetry beyond linear quivers*, [arXiv:2103.01243](#) [[INSPIRE](#)].
- [42] K. Intriligator and N. Seiberg, *Aspects of 3d $N = 2$ Chern-Simons-matter theories*, *JHEP* **07** (2013) 079 [[arXiv:1305.1633](#)] [[INSPIRE](#)].
- [43] V. Borokhov, A. Kapustin and X.-K. Wu, *Monopole operators and mirror symmetry in three-dimensions*, *JHEP* **12** (2002) 044 [[hep-th/0207074](#)] [[INSPIRE](#)].
- [44] V. Borokhov, A. Kapustin and X.-K. Wu, *Topological disorder operators in three-dimensional conformal field theory*, *JHEP* **11** (2002) 049 [[hep-th/0206054](#)] [[INSPIRE](#)].
- [45] D. Bashkirov and A. Kapustin, *Supersymmetry enhancement by monopole operators*, *JHEP* **05** (2011) 015 [[arXiv:1007.4861](#)] [[INSPIRE](#)].
- [46] M.K. Benna, I.R. Klebanov and T. Klose, *Charges of monopole operators in Chern-Simons Yang-Mills theory*, *JHEP* **01** (2010) 110 [[arXiv:0906.3008](#)] [[INSPIRE](#)].

- [47] B. Assel and S. Cremonesi, *The infrared physics of bad theories*, *SciPost Phys.* **3** (2017) 024 [[arXiv:1707.03403](#)] [[INSPIRE](#)].
- [48] A. Dey and P. Koroteev, *Good IR duals of bad quiver theories*, *JHEP* **05** (2018) 114 [[arXiv:1712.06068](#)] [[INSPIRE](#)].
- [49] B. Assel and S. Cremonesi, *The infrared fixed points of 3d $N = 4$ $USp(2N)$ SQCD theories*, *SciPost Phys.* **5** (2018) 015 [[arXiv:1802.04285](#)] [[INSPIRE](#)].
- [50] V. Pestun, *Localization of gauge theory on a four-sphere and supersymmetric Wilson loops*, *Commun. Math. Phys.* **313** (2012) 71 [[arXiv:0712.2824](#)] [[INSPIRE](#)].
- [51] C. Closset, T.T. Dumitrescu, G. Festuccia, Z. Komargodski and N. Seiberg, *Contact terms, unitarity, and F-maximization in three-dimensional superconformal theories*, *JHEP* **10** (2012) 053 [[arXiv:1205.4142](#)] [[INSPIRE](#)].
- [52] A. Kapustin, B. Willett and I. Yaakov, *Tests of Seiberg-like dualities in three dimensions*, *JHEP* **08** (2020) 114 [[arXiv:1012.4021](#)] [[INSPIRE](#)].
- [53] D. Gaiotto, *$N = 2$ dualities*, *JHEP* **08** (2012) 034 [[arXiv:0904.2715](#)] [[INSPIRE](#)].
- [54] O. Chacaltana and J. Distler, *Tinkertoys for Gaiotto duality*, *JHEP* **11** (2010) 099 [[arXiv:1008.5203](#)] [[INSPIRE](#)].
- [55] Y. Wang and D. Xie, *Classification of Argyres-Douglas theories from M5 branes*, *Phys. Rev. D* **94** (2016) 065012 [[arXiv:1509.00847](#)] [[INSPIRE](#)].
- [56] Y. Wang and D. Xie, *Codimension-two defects and Argyres-Douglas theories from outer-automorphism twist in 6d (2,0) theories*, *Phys. Rev. D* **100** (2019) 025001 [[arXiv:1805.08839](#)] [[INSPIRE](#)].
- [57] M. Buican and T. Nishinaka, *On the superconformal index of Argyres-Douglas theories*, *J. Phys. A* **49** (2016) 015401 [[arXiv:1505.05884](#)] [[INSPIRE](#)].
- [58] M. Buican and T. Nishinaka, *Argyres-Douglas theories, S^1 reductions, and topological symmetries*, *J. Phys. A* **49** (2016) 045401 [[arXiv:1505.06205](#)] [[INSPIRE](#)].
- [59] M. Buican and T. Nishinaka, *On irregular singularity wave functions and superconformal indices*, *JHEP* **09** (2017) 066 [[arXiv:1705.07173](#)] [[INSPIRE](#)].
- [60] L. Fredrickson, D. Pei, W. Yan and K. Ye, *Argyres-Douglas theories, chiral algebras and wild Hitchin characters*, *JHEP* **01** (2018) 150 [[arXiv:1701.08782](#)] [[INSPIRE](#)].
- [61] M. Dedushenko, *From VOAs to short star products in SCFT*, *Commun. Math. Phys.* **384** (2021) 245 [[arXiv:1911.05741](#)] [[INSPIRE](#)].
- [62] M. Dedushenko and Y. Wang, *$4d/2d \rightarrow 3d/1d$: a song of protected operator algebras*, [[arXiv:1912.01006](#)] [[INSPIRE](#)].
- [63] M. Buican, L. Li and T. Nishinaka, *Peculiar index relations, 2D TQFT and universality of SUSY enhancement*, *JHEP* **01** (2020) 187 [[arXiv:1907.01579](#)] [[INSPIRE](#)].
- [64] P.C. Argyres and M.R. Douglas, *New phenomena in $SU(3)$ supersymmetric gauge theory*, *Nucl. Phys. B* **448** (1995) 93 [[hep-th/9505062](#)] [[INSPIRE](#)].
- [65] P.C. Argyres, M.R. Plesser, N. Seiberg and E. Witten, *New $N = 2$ superconformal field theories in four-dimensions*, *Nucl. Phys. B* **461** (1996) 71 [[hep-th/9511154](#)] [[INSPIRE](#)].
- [66] M. Del Zotto and A. Hanany, *Complete graphs, Hilbert series, and the Higgs branch of the 4d $N = 2$ (A_n, A_m) SCFTs*, *Nucl. Phys. B* **894** (2015) 439 [[arXiv:1403.6523](#)] [[INSPIRE](#)].

- [67] J. Song, *Superconformal indices of generalized Argyres-Douglas theories from 2d TQFT*, *JHEP* **02** (2016) 045 [[arXiv:1509.06730](#)] [[INSPIRE](#)].
- [68] S.S. Razamat and B. Willett, *Down the rabbit hole with theories of class \mathcal{S}* , *JHEP* **10** (2014) 099 [[arXiv:1403.6107](#)] [[INSPIRE](#)].
- [69] S. Kim, *The complete superconformal index for $N = 6$ Chern-Simons theory*, *Nucl. Phys. B* **821** (2009) 241 [*Erratum ibid.* **864** (2012) 884] [[arXiv:0903.4172](#)] [[INSPIRE](#)].
- [70] C. Krattenthaler, V.P. Spiridonov and G.S. Vartanov, *Superconformal indices of three-dimensional theories related by mirror symmetry*, *JHEP* **06** (2011) 008 [[arXiv:1103.4075](#)] [[INSPIRE](#)].