

Three Peroxisome Proliferator-Activated Receptor Isotypes from Each of Two Species of Marine Fish

Michael J. Leaver,* Evridiki Boukouvala,* Efthimia Antonopoulou,* Amalia Diez, Laurence Favre-Krey, M. Tariq Ezaz, José M. Bautista, Douglas R. Tocher, and Grigorios Krey

Institute of Aquaculture (M.J.L., M.T.E., D.R.T.), University of Stirling, Stirling FK9 4LA, United Kingdom; National Agricultural Research Foundation (E.B., E.A., L.F.-K., G.K.), Fisheries Research Institute, Nea Peramos, 64007 Kavala, Greece; and Departamento de Bioquímica y Biología Molecular IV (A.D., J.M.B.), Facultad de Veterinaria, Universidad Complutense de Madrid, 28040 Madrid, Spain

The cloning and characterization of cDNAs and genes encoding three peroxisome proliferator-activated receptor (PPAR) isotypes from two species of marine fish, the plaice (*Pleuronectes platessa*) and the gilthead sea bream (*Sparus aurata*), are reported for the first time. Although differences in the genomic organization of the fish PPAR genes compared with their mammalian counterparts are evident, sequence alignments and phylogenetic comparisons show the fish genes to be homologs of mammalian PPAR α , PPAR β/δ , and PPAR γ . Like their mammalian homologs, fish PPARs bind to a variety of natural PPAR response elements (PPREs) present in the promoters of mammalian or piscine genes. In contrast, the mRNA expression pattern of PPARs in the two fish species differs from that observed in other vertebrates. Thus, PPAR γ

is expressed more widely in fish tissues than in mammals, whereas PPAR α and β are expressed similarly in profile to mammals. Furthermore, nutritional status strongly influences the expression of all three PPAR isotypes in liver, whereas it has no effect on PPAR expression in intestinal and adipose tissues. Fish PPAR α and β exhibit an activation profile similar to that of the mammalian PPAR in response to a variety of activators/ligands, whereas PPAR γ is not activated by mammalian PPAR γ -specific ligands. Amino acid residues shown to be critical for ligand binding in mammalian PPARs are not conserved in fish PPAR γ and therefore, together with the distinct tissue expression profile of this receptor, suggest potential differences in the function of PPAR γ in fish compared with mammals. (*Endocrinology* 146: 3150–3162, 2005)

PEROXISOME PROLIFERATOR-activated receptors (PPARs) are ligand-inducible transcription factors belonging to the nuclear hormone receptor (NHR) superfamily. To date, three PPAR isotypes have been identified in mammals, birds, and amphibians, termed PPAR α , PPAR γ , and PPAR β or δ . Each isotype is a product of a separate gene and each one has a distinct tissue distribution (1–3).

PPARs were originally identified and named as receptors that are activated by a diverse range of chemicals termed peroxisome proliferators, previously identified as the agents responsible for peroxisomal proliferation in rodent liver (4). Subsequent work has led to the identification of various natural and synthetic PPAR ligands that include a number of unsaturated fatty acids, eicosanoids, hypolipidemic agents, and antidiabetic drugs (5–7). Transcriptional activation of target genes by PPARs requires the presence of peroxisome

proliferator, or PPAR response elements (PPREs), in the promoter of target genes. PPREs are direct repeat elements of the DR1 type (direct repeat spaced by 1 bp), and PPARs bind as heterodimers with the retinoid X receptor on PPREs (8, 9). In the presence of ligands for both receptors, conformational changes of the receptors' ligand binding domain (LBD, or E domain) result in the release of corepressor proteins, recruitment of coactivator proteins, and subsequent assembly of a protein complex that enhances transcription of the target gene (10). A number of PPAR target genes have been characterized to date. Most of these genes are known to have roles in lipid and glucose metabolism, whereas PPAR ligands are themselves, in many cases, the substrates and/or products of the enzymes whose genes PPARs are known to regulate (11). Thus, during the last decade PPARs have emerged as critical regulators of lipid homeostasis in mammals. Due to obvious medical and pharmacological interest, most studies on PPARs have concentrated on mammalian genes and proteins, with only sporadic reports about PPARs from other vertebrates. As far as PPARs from fish species are concerned, a complete cDNA with similarity to PPAR γ has been isolated from Atlantic salmon (12) and partial cDNAs for two distinct PPAR β -like proteins have been described from zebrafish (13). More recently, the bioinformatic analysis of the whole genome of the pufferfish *Fugu rubripes* suggested the presence of single homologs of the human PPAR β and γ genes and two homologs of the human PPAR α gene in this species (14). Consequently, the exact number of genes and/or the presence of distinct PPAR isotypes in fish have not been determined. In addition, it is not known whether the differ-

First Published Online March 24, 2005

* M.J.L., E.B., and E.A. have contributed equally to this work.

Abbreviations: ACO, Rat acyl-coenzyme A oxidase; CAT, chloramphenicol acetyltransferase; CLA, conjugated linoleic acid; Ct, cycle threshold; DR1, direct repeat spaced by 1 bp; ETYA, eicosatetraynoic acid; FBS, fetal bovine serum; LBD, ligand binding domain; mRXR β , mouse RXR β ; NHR, nuclear hormone receptor; nt, nucleotide; PFOA, perfluorooctanoic acid; PPAR, peroxisome proliferator-activated receptor; PPRE, PPAR response elements; Q-PCR, quantitative PCR; RACE, rapid amplification of cDNA ends; RNase, ribonuclease; SBL, sea bass larval; SMART, switching mechanism at 5' end of RNA transcript; SSC, standard saline citrate.

Endocrinology is published monthly by The Endocrine Society (<http://www.endo-society.org>), the foremost professional society serving the endocrine community.

ent PPAR isotypes, if present in fish, act through similar mechanisms and perform the same critical functions in lipid metabolism as they do in mammals. Thus, the study of piscine PPARs could provide new insights to PPAR biology, elucidate the evolution of structure and function of these receptors, and provide a clearer understanding of the physiological mechanisms which determine lipid and fatty acid homeostasis in vertebrates.

As a prelude to such studies, we have undertaken a search for PPAR genes in two species of marine fish, the plaice (*Pleuronectes platessa*) and the gilthead sea bream (*Sparus aurata*, sea bream herein). We report here the cloning and characterization of cDNAs and genes encoding for three PPAR isotypes from each of these fish species.

Materials and Methods

Animals

Wild plaice were caught from the UK coast, and sea bream were obtained from farmed stock in Greece. Before use, all fish were maintained in recirculating sea water and fed *ad libitum* unless otherwise indicated. Before sampling, fish were anesthetized and killed by decapitation.

Experimental animals

National and institutional regulations, in accordance with the European Union's relevant legislation, have been followed regarding animal experimentation.

Gene and cDNA isolation

1. Genomic clones. Plaice genomic DNA was prepared by lysis of whole blood as previously described (15). Sea bream genomic DNA was prepared from muscle tissue with the DNeasy tissue kit (QIAGEN, Hilden, Germany) according to the manufacturer's instructions.

The plaice PPAR genes were isolated from a genomic library constructed in λ FIXII (Stratagene, La Jolla, CA), which was screened, at low stringency [60 C in 20 mM sodium phosphate, 300 mM NaCl (pH 7.7), 7% sodium dodecyl sulfate for hybridization, followed by extensive washing in 1 \times standard saline citrate (SSC) at room temperature], with

a DNA probe corresponding to the ligand binding region of a plaice PPAR γ cDNA (16). The resulting positive recombinant phages were subsequently screened with the same probe at higher stringency (65 C for hybridization followed by washing in 0.1 \times SSC) before sequence characterization.

Sea bream partial genomic PPAR clones were isolated by direct PCR amplification of genomic DNA with the Expand High Fidelity PCR system (Roche Applied Science, Mannheim, Germany) and primers based on highly conserved regions of PPARs from other phyla and/or the plaice PPAR sequences. Thus, primers 5'-CCA AAA GAA GAA CCG CAA CAA G and 5'-TTG CAG GAG CGG GTG CAA CGA CG, termed aF and aR, respectively, were used to amplify the PPAR α gene. The PPAR β amplicon was obtained with primers 5'-ATG GAA TGG TTT CAG GAA ACT G and 5'-CTA ATA CAT GTC TTT GTA GAT CTC CTG, termed bF and bR, respectively. For PPAR γ , three primer pairs, 5'-GTC GAC ATG GTG GAC AC' and 5'-TGT AAT CCA TGT TCG TCA GG (g1F and g1R, respectively), 5'-GCT GCA AGG GTT TCT TCA G and 5'-CGT TGT GTG ACA TGC CG (g2F and g2R, respectively), and 5'-GGG AGC AGT TTA TTA ATT GCA AGC AGC and 5'-AAT CTC CGT CTT CTT CAG CAG CTG GAT G (g3F and g3R, respectively), were used to amplify different segments of the gene. The approximate positions on the respective genes on which these primers bind are shown in Fig. 1. All genomic fragments were cloned into the pCR Script vector (Stratagene) for further analyses.

2. cDNA clones. Total sea bream liver RNA was reverse transcribed with the Expand Reverse Transcriptase (Roche). The resulting cDNA was used as template for rapid amplification of cDNA ends (RACE) PCR for the amplification of the 5'- and 3'-ends of the receptors, with primers derived from partial genomic sequences. Either the SMART (switching mechanism at 5' end of RNA transcript) RACE kit (BD Biosciences, Basingstoke, UK) or the 5'/3' RACE kit (Roche) were used in these experiments. For 5'-end amplification, the gene-specific primers used were 5'-GCC ACC TCT TTC TCC ACC A, 5'-CGG CCC TCT TCT TGG TCA T, 5'-CGA CAG TGA AGA TCA CAG TGA TC for PPARs α , β , and γ , respectively. For the 3'-end amplification of PPAR α , the gene-specific primer used was 5'-CTC TGA TGA ACA AAG ACG GGA. Isolation of the entire coding sequences of the PPAR isotypes was performed with RT-PCR on total liver RNA with primers 5'-CAT TCC ATG TCT GCC TTG ATC and 5'-TCA GTA CAT GTC CCT GTA GAT TTC TTG C for PPAR α , 5'-ATG GAA TGG TTT CAG GAA ACT and 5'-CTA ATA CAT GTC TTT GTA GAT CTC CTG for PPAR β , and 5'-GTC GAC ATG GTG GAC AC and 5'-TAC TCT TGT TAA AGG CTA ATA CAA GTC for

FIG. 1. Sea bream and plaice PPAR gene structures. Schematic diagram, approximately to scale, for the structure of the sea bream (*S. aurata*) and plaice (*P. platessa*) PPAR genes. The positions of primers used to amplify the sea bream genes are indicated. The exons are shaded according to the corresponding protein domains that they encode; C and E domains refer to the DNA binding and ligand binding domains, respectively. Alternatively spliced exons and the positions of initiation and termination codons are indicated. TN indicates a Tc1-like transposon.

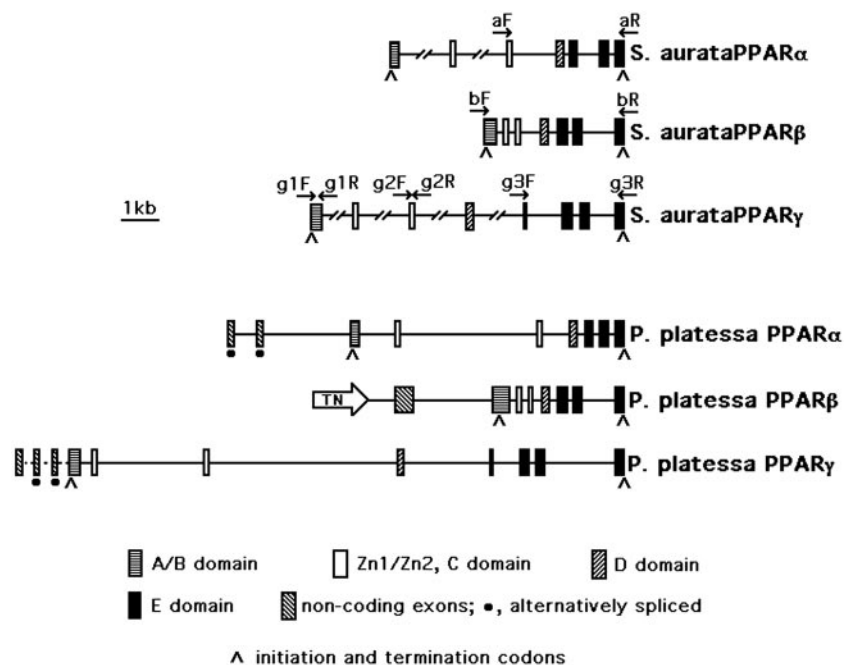

PPAR γ (initiation and termination codons are *underlined*). All cDNAs were cloned into the pCR Script vector (Stratagene) for further analyses.

Plaice cDNAs were isolated by RACE-PCR (SMART cDNA synthesis kit; BD Biosciences) and primers designed from the predicted coding regions of plaice PPAR genes. cDNAs were amplified with *Pfu* polymerase (Stratagene) using the SMART RACE anchor primer and the gene specific reverse primers 5'-TTT TAA TAC ACG TCC CGG GTT TCC, 5'-CTG AGC TGA AGA ACA CAT TAT CAT, 5'-CTC TAA TAC AAG TCC TTC ATG for PPAR α , β , and γ , respectively. After DNA synthesis, PPAR sequences were ligated to *EcoRV*-digested pBluescriptKS+ (Stratagene) and propagated as plasmid inserts.

Phylogenetic analysis

The LBDs of PPARs from a variety of species were used to perform phylogenetic analysis. *Xenopus*, chick, and human PPAR sequences were obtained from the GenBank/EMBL databases. *Fugu*, *Tetraodon*, and zebrafish PPAR LBD sequences were obtained by searching the Ensembl (www.ensembl.org) genomic databases (zebrafish release WTSI Zv4, September 2004; *Fugu* release version 2.0, May 2004, *Tetraodon* release, September 2004) against plaice PPAR α , β , and γ cDNA sequences using TBLASTX. LBD sequences were aligned using CLUSTALW (17), including the LBD region of human *rev-erba* (accession no. NM021724) as an outgroup. Phylogenetic trees were inferred using the Neighbor joining method of Saitou and Nei, 1987 (18), bootstrapped through 1000 iterations to test for robustness and plotted using Njplot (<http://pbil.univ-lyon1.fr/software/njplot.html>).

Northern and Southern blot analysis

RNA was isolated from male plaice tissues using TriReagent (Sigma, Poole, UK), treated with glyoxal and fractionated by agarose gel electrophoresis (15). Gels were blotted to Biodyne B nylon membrane (Pall Gelman Sciences, Northampton, UK) and hybridized to ³²P-deoxy-CTP (ICN Biochemicals, Basingstoke, UK) labeled probes for the various plaice PPAR cDNAs. Plaice PPAR probes were derived by PCR from the 5' ends of the PPAR cDNAs using primers directed to the regions encompassing the translation initiation sites and the boundary of the first coding exons, thereby producing probes for the regions corresponding to the A/B domains of the PPARs. These fragments were gel purified, and 25 ng of each were labeled with [α -³²P]deoxy-CTP by random priming. The same probes were hybridized to Southern blots (Biodyne B nylon membrane) of agarose gel-resolved *Sst*I-digested plaice genomic DNA (14). All blots were washed at high stringency (0.1 \times SSC, 65 C) before autoradiography.

Riboprobes and ribonuclease (RNase) protection assay

Sea bream PPAR mRNA expression was assessed by the RNase protection assay using a commercial kit (RNase protection kit; Roche). For the synthesis of sea bream PPAR isotype-specific riboprobes, the fragment encoding the D domain of each isotype was amplified by PCR. For PPAR α , primers 5' TTG GAT CCG CCA TTC GGT TTG GTC and 5' AGA ATT CGC TGA AGT TCT TCA T were used to amplify a 152-bp fragment [nucleotides (nt) 571–722 of cDNA]; for PPAR β , primers 5' TTG GAT CCG CGA TCC GAT ACG GAC and 5' AGA ATT CGA TGC TGC GGG CCC T were used to amplify a 177-bp fragment (nt 877–1053 of cDNA); for PPAR γ , primers 5' TTG GAT CCG CTA TTC GTT TTG and 5' AGA ATT CCG CGT TAT CTC CGG T were used to amplify a 202-bp fragment (nt 902–1103 of cDNA). For directional cloning into the pBluescript KS vector (Stratagene), all upstream primers contained a *Bam*HI restriction enzyme site and all downstream primers an *Eco*RI site (*underlined* in the primer sequences above). A 204-bp β -actin fragment (nt 228–431 of GenBank accession no. AY148350) was amplified by RT-PCR, from sea bream liver total RNA with primers 5' GAC CAA CTG GGA TGA CAT GG and 5' GCA TAC AGG GAC AGC ACA GC and was cloned into the pCR Script vector (Stratagene). Antisense PPAR riboprobes were synthesized by T3 RNA polymerase (Promega, Madison, WI) transcription on the above *Bam*HI-digested plasmids. The β -actin plasmid construct was digested with *Not*I and the antisense riboprobe was synthesized by T7 RNA polymerase (Promega) transcription. All riboprobes were labeled with [α -³²P]CTP (800 Ci/mmol; Amersham Biosciences Europe, Freiburg, Germany) and their specific

activity was quantified as described in the manual of the RNase protection kit. Total RNA from sea bream tissues, eggs, and larvae was extracted with the RNeasy tissue kit (QIAGEN) according to the manufacturer's instructions. For PPAR expression, 8 μ g of total RNA from each tissue sample were hybridized simultaneously with all three isotype-specific probes (~3 fmol of each) before being subjected to digestion by RNases. For β -actin expression, 5 μ g of total RNA were used with approximately 80,000 cpm of the riboprobe. The protected fragments were separated on a 6% polyacrylamide gel containing 7 M urea. Signals were visualized by autoradiography and were quantified either by phosphor analysis (Molecular Imager FX system; Bio-Rad, Hercules, CA) or image analysis (Gel-Pro version 3.0, Media Cybernetics, Silver Spring, MD). Where applicable, PPAR mRNA expression was normalized to β -actin expression.

Quantitative PCR (Q-PCR)

Total RNA was extracted from sea bream tissues as above and was quantified fluorometrically. First-strand cDNA was synthesized using the High-Capacity cDNA Archive Kit (Applied Biosystems, Foster City, CA) according to the manufacturer's instructions. Relative abundance of mRNAs was assessed using the 5' fluorogenic nuclease assay on an ABI Prism 7000 sequence detector system (Applied Biosystems) using reagents of the TaqMan system (Applied Biosystems). The TaqMan probes for all PPAR isotypes and the reference gene (α -tubulin, GenBank accession no. AY326430) were designed at an exon-intron junction to avoid detection of DNA contaminants. Primer pairs were designed to amplify a short amplicon to which the probe, labeled with 6-carboxyfluorescein (6-FAM) reporter dye at the 5'-end and carboxytetramethylrhodamine (TAMRA) quencher dye at the 3'-end, was annealed. Primers for PPAR α were 5'-TTC GTG GCT GCC ATT ATC TG and 5'-CAC CAA AGG CAC ATC CAC C; for PPAR β , 5'-TGT TTG TTG CTG CCA TCA TTC and 5'-TGC TCC ACC TGC TTC ACG T; for PPAR γ , 5'-GCC TCA ATG TCG GCA TGT and 5'-TCC TTC TCC GCC TGG G; for α -tubulin 5'-CGC AAA CTG GCT GAC CAG T and 5'-CGC TCC ATC AGC AGA GAG G. The TaqMan probes for PPAR α , β , γ , and α -tubulin were 5'-TGC GGA GAT CGC CCA GGC C, 5'-CTG TGG AGA TCG TCC CGG GCT AAT G, 5'-ACA CAA CGC CAT TCG TTT TGG CC, and 5'-TCC TTT GGT GGA GGA ACC GGC TC, respectively. PCRs for all genes were performed by 40 cycles of amplification in a two-step program (95 C denaturation step for 15 sec, followed by a 57 C annealing/extension fluorescence detection step for 30 sec). All samples were run in triplicate and quantified by normalizing the PPAR signal to that of α -tubulin by the 2^{- $\Delta\Delta$ Ct} method [cycle threshold (Ct) method, ABI Prism 7700 User Bulletin No. 2].

For plaice, 1 μ g of total RNA from various tissues was copied to cDNA with Powerscript reverse transcriptase (BD Biosciences) and 2.5 pmol of oligo-deoxythymidine. Aliquots of these reactions were then subjected to Q-PCR using a SYBR Green containing PCR mix (ABgene, Epsom, Surrey, UK) and primers for PPAR α , 5'-TTC GTC GTC CTT TTA GCG ACA TGA and 5'-TTT CCT GCA CCA GCT GGG CGT GCT; for PPAR β , 5'-TAA GAA AGC CCT TCA GTG AGA TCA and 5'-TCT TTT GGA CGA GCA GAG CGT TCT; for PPAR γ , 5'-TCA GGA AAC CTT TCT GTC AAA TGA and 5'-GCA GCT GGA TGA GGT GCA CGT GGT. Reactions were run in a two-stage protocol (95 C for 15 sec and 57 C for 30 sec), during which time fluorescence was measured in a Techne Quantica (Cambridge, UK) Q-PCR machine. Each sample was measured in triplicate and sample Ct values were compared with Ct values for dilutions of purified and quantified cDNA run under identical conditions.

Production of a fish PPAR γ antibody

A peptide sequence was employed to generate specific antibodies against PPAR γ and was chosen by analysis of multiple alignments of the deduced plaice and sea bream PPAR γ protein sequences. The peptide, NH₂-VDTQQLLAWPVGFLNAVDLSELDDSSHSLC-COOH, was chosen on the basis of its likely specificity for piscine PPAR γ and is located in the A/B domain of this isotype. The peptide was synthesized and keyhole limpet haemocyanin (KLH) conjugated by GENOSPHERE (Genosphere Biotechnologies, Paris, France). New Zealand rabbits were immunized with the PPAR γ peptide by intradermal injection of 1 mg peptide in Freund's complete adjuvant at about 40 sites, followed by

three boosts with 0.5 mg peptide at wk 5, 10, and 17. Serum was collected after wk 22.

EMSA

Plaice and sea bream PPAR proteins, as well as mouse RXR β (mRXR β) (9) were obtained by *in vitro* transcription and translation using the TNT coupled reticulocyte lysate system (Promega). EMSA was performed as previously described (9). The rat acyl-coenzyme A oxidase (ACO) and Cyp4A6z probes have been previously described (Refs. 19–21 and references therein). The GSTA1.1–3 probes correspond to the presumed PPREs of the plaice GSTA1 promoter (15) and specifically between nt positions 3713–3734 (GSTA1.1), 3718–3740 (GSTA1.2), and 3771–3793 (GSTA1.3) of GenBank accession no. X95199. For antibody-induced supershifts, 2 μ l of PPAR γ antibody or preimmune serum were introduced to the reaction mix simultaneously with the proteins and probe.

Fasting and refeeding experiments

A total of 16 fish (sea bream) were kept unfed for 72 h. At the end of the fasting period (0 h), three fish were removed and several tissues (liver, intestine, mesenteral adipose) were obtained for RNA extraction as described above. The remaining fish were allowed to feed to satiation. An additional three fish were removed at 1, 3, and 24 h after feeding, and RNA was extracted from the excised tissues for the RNase protection assay, as described above.

Transfection assays

All plaice and sea bream PPAR cDNAs were cloned into pcDNA3, verified by sequencing, and prepared for transfection by endotoxin-free plasmid purification (QIAGEN). Sea bass larval (SBL) cells were maintained in DMEM with 10% fetal bovine serum (FBS). Twenty-four hours before transfection, cells were harvested by trypsinization, resuspended in DMEM with 10% charcoal/dextran-treated FBS (Pierce, Rockford, IL), diluted as necessary, and distributed to 12-well tissue culture plates (10⁵ cells/well). Cells were transfected 24 h later using, per well, 1 μ g of PPRE-reporter plasmid, 0.3 μ g of PPAR construct, 0.2 μ g of pCMV β gal, and 7.5 μ l of Superfect reagent (QIAGEN) according to the transfection reagent manufacturer's instructions. The reporter construct consisted of the mouse Cyp4A6z PPRE linked to the minimal mouse thymidine kinase promoter placed upstream of a chloramphenicol acetyltransferase (CAT) gene, as previously described (19). After 4 h, cells were washed once with PBS and then incubated in 1 ml DMEM with 10% charcoal/dextran-treated FBS for a further 20 h. Potential activators were added to each well in 5 μ l of ethanol and cells harvested 24 h later. All fatty acids and eicosatetraenoic acid (ETYA) were obtained from Sigma. Conjugated linoleic acid (CLA) was obtained from Nu-Chek Prep Inc. (Elysian, MN). Wy-14,643 and rosiglitazone were obtained from Axxora (Nottingham, UK). CAT expression was quantified by commercial ELISA kit (Roche) and β -galactosidase by spectrophotometric enzyme assay using o-nitrophenylgalactopyranoside as substrate. After subtracting mock-transfected backgrounds, results were expressed as the fold increase in CAT, normalized to β -galactosidase, with respect to the ethanol control. Experiments were repeated at least twice, and within each experiment all treatments were in triplicate.

Western blot

SBL cells were transfected with plaice and sea bream PPAR constructs as described above. After 48 h, cells were harvested and total extracts subjected to SDS-PAGE on 10% polyacrylamide. Gels were then blotted to nitrocellulose membrane, followed by blocking and incubation with the PPAR γ -specific antibody. Cross-reacting protein was visualized by incubation with anti-Ig-alkaline phosphatase and staining with 5-bromo-4-chloro-3-indolyl phosphate and nitro blue tetrazolium.

Results

Fish PPAR gene structures

Genes for PPARs were isolated from plaice and sea bream by different methods. Two independent screenings of a pla-

ice genomic library resulted in the isolation of a total of 46 λ phage recombinants. Five of these were shown to contain PPAR γ -related sequences all from the same locus; two others contained PPAR α -related sequences, also from a single locus, and two contained PPAR β -related sequences from a single locus. The remaining recombinants contained sequences with significant similarity to other members of the NHR superfamily from other species. Sea bream PPAR genes were isolated by PCR using primers designed from regions known to be conserved in PPARs from other phyla. Plaice and sea bream genomic fragments were selected for further analysis on the basis that they were likely to encode distinct PPAR genes, and extensive sequencing revealed three PPAR genes from each of the fish species (Fig. 1).

The positions of coding exon/intron boundaries in the plaice and sea bream differed slightly from those of mammalian and amphibian PPARs. All mammalian PPAR genes consist of six coding exons, the last two of which encompass the LBD. In contrast, in the plaice and sea bream PPAR α and PPAR β , the region corresponding to the first exon of the mammalian LBD is encoded by two exons, whereas in the plaice and sea bream PPAR γ is encoded by three exons (Fig. 1). All other piscine coding exon boundaries were in essentially identical positions in fish and mammalian PPAR genes (Fig. 2). More generally, it is notable that the plaice and sea bream PPAR genes are up to ten times smaller than their mammalian counterparts, due to the much smaller introns present in the fish genes. This is also true of other fish genes (15) and is indicative of the small size of some fish genomes, in plaice estimated to be about one fifth the size of the mammalian genome (22), a situation which greatly facilitated the gene first approach to cloning described here. Also notable is the presence of a Tc1-like transposon upstream of the first identified exon of the plaice PPAR β gene (Fig. 1). The presence of these transposons in the plaice genome has been noted previously (15, 23).

To confirm that the isolated genomic sequences encode for functional gene products, primers were designed and were used in RACE and RT-PCR experiments with cDNA derived from liver RNA. Sequence of the amplified products revealed the presence of the corresponding transcripts. Furthermore, it confirmed the predicted exon/intron structures of the plaice and sea bream PPAR genes and also demonstrated the presence of 5' noncoding exons and alternatively spliced products in the plaice genes (Fig. 1). Those from PPAR α and β were located in the genomic clones sequenced, but those from PPAR γ were outside of the sequenced portion of the plaice gene. Both the plaice PPAR α and PPAR γ mRNAs exist as alternatively spliced products based on the fact that products with distinct 5'-untranslated regions were obtained from 5'-RACE experiments.

All of the predicted initiation codons conform to typical Kozak consensus sequences, and in the case of the plaice PPAR α and PPAR β these initiation codons were preceded by in-frame termination codons. From the positions of potential translation initiation codons, it is possible that the plaice PPAR γ protein could exist in two alternative forms, one having an N-terminal extension of 20 amino acid residues. Mammalian PPAR γ proteins are known to exist in two forms (PPAR γ 1 and γ 2) resulting from the use of alternative gene

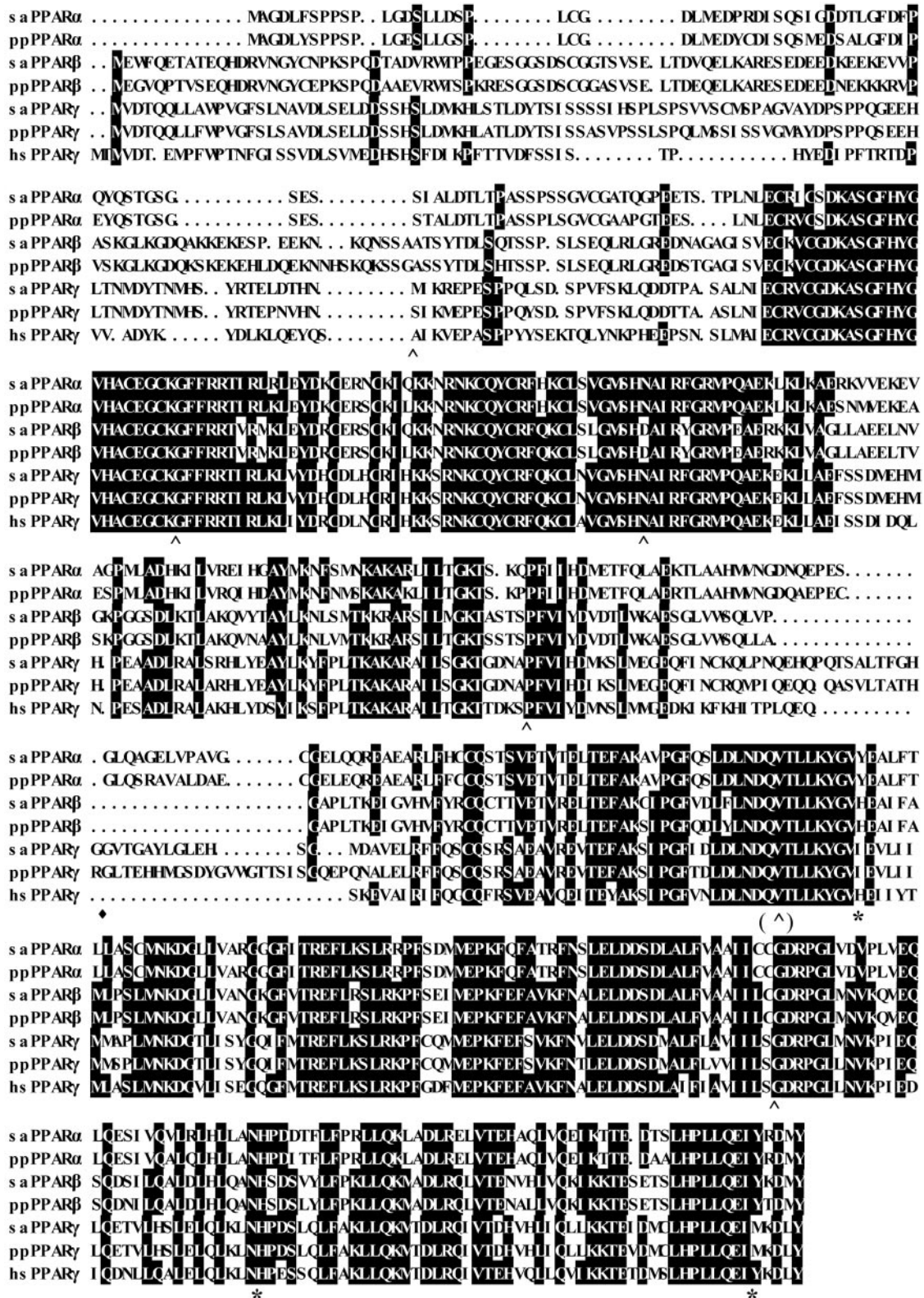

FIG. 2. Comparison of PPARs from plaice and sea bream and human PPAR γ . Alignment of the plaice (pp) and sea bream (sa) PPAR isotypes with the human (hs) PPAR γ was generated with ClustalW and identical residues present in four or more of the seven sequences are shaded. The positions of residues shown to be important in binding the carboxylic head group of the ligand in human PPARs are indicated with an asterisk below the sequences. Also below the sequences, the positions of exon/intron boundaries common to all PPARs are indicated by an insertion sign—^; the position of an exon/intron boundary found only in fish species is indicated by the insertion sign in parentheses—(^), and the position of the exon/intron boundary, which is only present in the fish PPAR γ genes is indicated by a solid diamond (♦).

promoters and splicing (24), although there is no obvious conservation of sequence between the plaice and mammalian PPARs in this region. We have not attempted to investigate whether the plaice PPAR γ exists in alternative forms, but the predicted alternative translation initiation codon is a poor match to the Kozak consensus.

Despite extensive library screening, PCR analysis, and clone characterization, we have not found more than three distinct *PPAR* genes in either plaice or sea bream. However, it is possible that more than one gene for each PPAR isotype could exist in some fish species. There are reports of multiple *PPAR β* genes in zebrafish (13) and for two distinct *PPAR α* genes in the pufferfish *Fugu rubripes* (14). Furthermore, we have found two distinct *PPAR β* genes in Atlantic salmon (Leaver, M. J., M. T. Ezaz, D. R. Tocher, E. Boukouvala, and G. Krey, unpublished results). Therefore, to establish whether additional loci could encode genes with high similarity to each of the *PPAR* genes we identified, we performed Southern blots of *Sst*I digested plaice genomic DNA, which we probed with cDNA portions corresponding to the least conserved A/B domain of each of the plaice PPARs. This procedure failed to identify hybridizing fragments other than those expected from the genomic sequences (Fig. 3). Similar results were also obtained from sea bream (not shown), suggesting that each of the identified genes is encoded by a single locus. Thus, if additional *PPAR* genes are present in the genomes of these two species, these must diverge substantially at least in the sequence of the A/B domain.

PPAR sequence comparisons

From the alignment of the deduced amino acid sequence of the plaice and sea bream PPARs (Fig. 2), it is clear that the DNA-binding (C) and ligand-binding (E) domains are par-

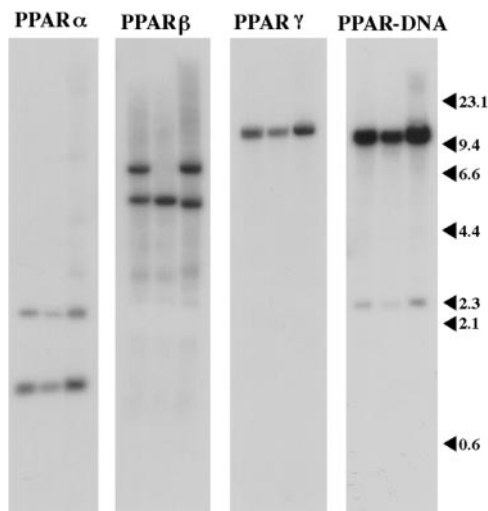

FIG. 3. Southern blot of plaice DNA. DNA from three individual plaice was extracted, digested with *Sst*I, resolved by agarose gel electrophoresis and blotted by Southern. Each blot was hybridized with a probe corresponding to the A/B domain of each plaice PPAR isotype as indicated, or with a probe corresponding to the plaice PPAR γ DNA binding domain (PPAR-DNA). The positions of DNA size markers (in kilobase pairs) are indicated. Note the restriction fragment length polymorphism (heterozygosity) at the *PPAR β* locus.

ticularly conserved among all isoforms from both species. However, when comparing the same PPAR isotype from the two species, the sequence similarity extends to the entire molecule and exceeds 85% identity. In contrast, when compared with PPARs from other vertebrate phyla (*e.g.* *Xenopus* or human) significant identity (>70%) is observed only in the C and E domains with the A/B domain being the least conserved (<30% in PPARs α and γ and <15% in PPAR β). Also notable is the reduced identity (~65%) in the E domain between the fish and human or *Xenopus* PPAR γ .

Phylogenetic analysis

The LBD sequences of the plaice and sea bream PPARs were used, along with those of human, chick, and *Xenopus* PPARs, and the four identified *Fugu* PPARs (14), to generate phylogenetic plots. The plots also included the LBD sequences deduced from the four zebrafish *PPAR* genes identified on chromosomes 4, 18, 25, and on an as-yet-unplaced genomic sequence (scaffold zv4-NA15249). An additional

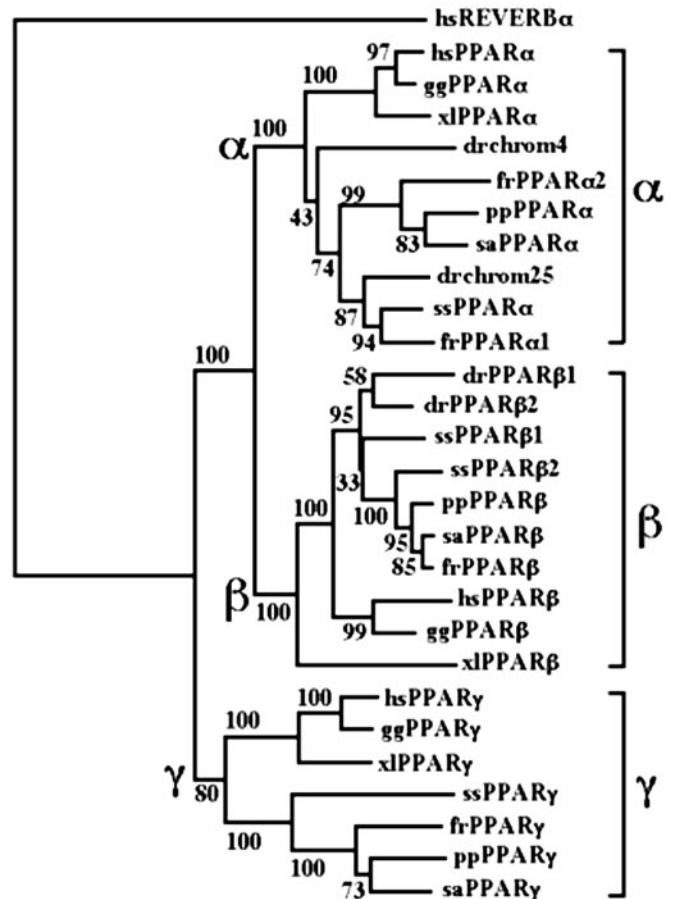

FIG. 4. Neighbor-joining tree for the LBD of PPARs from diverse species. The deduced amino acid sequences corresponding to the LBD of the PPAR isoforms from plaice (pp), sea bream (sa), Atlantic salmon (ss), human (hs), chick (gg), *Xenopus* (xl), zebrafish (dr), and *Fugu* (fr) were used to construct the tree. The tree was rooted to the LBD sequence of human rev-erbA and was inferred and tested for robustness by bootstrapping. Percentage frequencies with which the tree topology presented here were replicated after 1000 iterations are indicated. Main branches corresponding to PPAR α , β , and γ subfamilies are indicated.

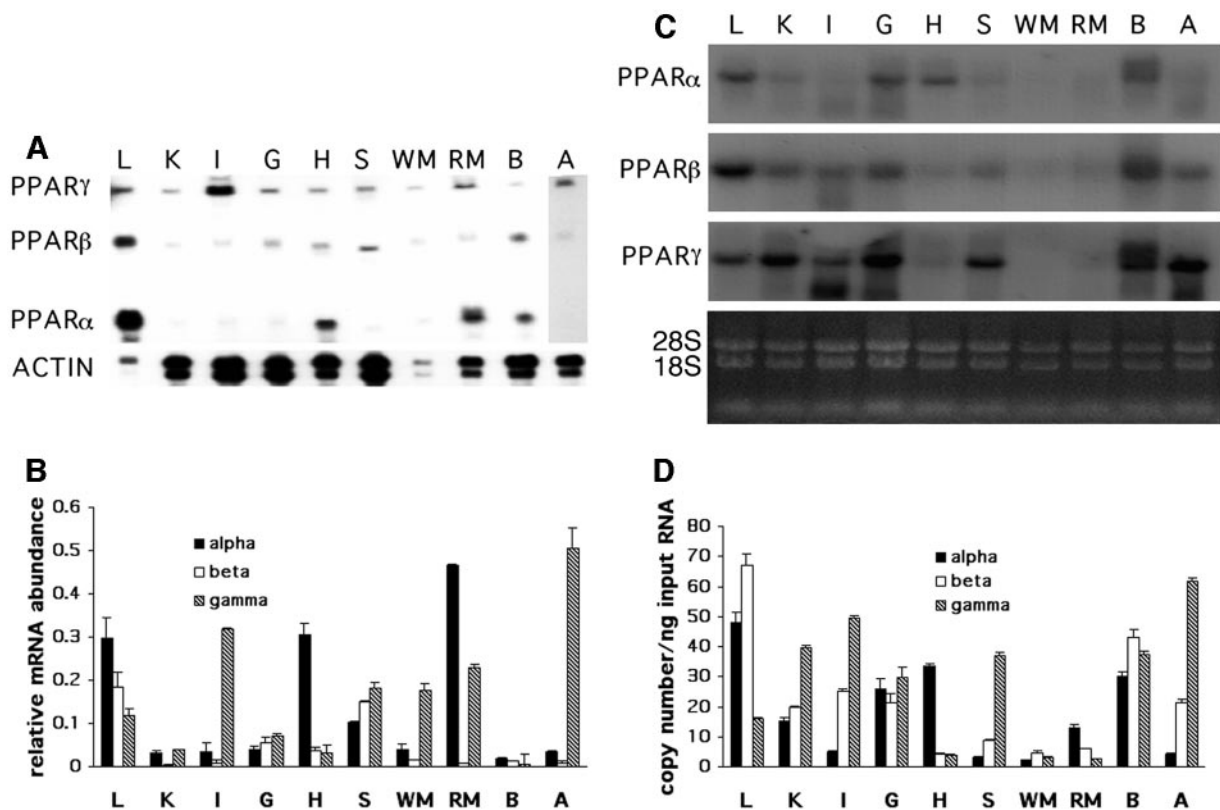

FIG. 5. Tissue expression profile of sea bream and plaice PPARs. A, RNase protection for expression of sea bream PPARs in different tissues. L, Liver; K, kidney; I, intestine (proximal to cecum); G, gill; H, heart; S, spleen; W, white muscle; R, red muscle; B, brain; A, adipose (mesenteral). Each lane contains the RNase-protected fragments from 8 μ g of total RNA incubated with 3 fmol of radiolabeled riboprobes corresponding to the D domain of each receptor. B, Q-PCR for expression of sea bream PPARs. The graph represents mean and SD of values from triplicate measurements. Values are arbitrary units relative to the reference (α -tubulin). Tissues are as in A. C, Northern blot for expression of plaice PPARs in different tissues. Each lane contained 5 μ g of total RNA and replicate blots were hybridized to probes corresponding to the A/B domain of each plaice PPAR isotype. Tissues are as in panel A. D, Q-PCR for expression of plaice PPARs. The graph represents mean and SD of values from triplicate measurements. Values are given as copy number relative to total input RNA. Tissues are as in A. The levels of the internal standards, β -actin (panel A) as well as of α -tubulin (not shown), for these assays were consistently low in tissues such as the liver and muscle in both species and bore no relation to the total RNA input. Thus, they could not be used for comparison of PPAR expression in the different tissues.

PPAR gene, identified on zebrafish chromosome 11 and related to PPAR γ according to sequence comparisons, is as yet incompletely compiled and was excluded from the phylogenetic analysis. Scanning the genome of *Tetraodon nigroviridis*, the third fish species for which entire genome data are available, also resulted in the prediction of four PPAR genes. Specifically, two PPAR α -like genes were identified one of which is located on chromosome 13 and the other on chromosome 19; a single PPAR β -like gene was identified on chromosome 9, and a single PPAR γ -like gene on chromosome 11. These genes exhibited high identity to the corresponding genes from *Fugu* and thus were not included in our phylogeny. Instead, four Atlantic salmon LBD regions derived from distinct genes (Leaver, M. J., M. T. Ezaz, D. R. Tocher, E. Boukouvala, and G. Krey, unpublished results) were included. The resulting phylogenetic tree (Fig. 4) shows clear and robust (based on high bootstrap values for tree topology) clustering of the sequences into three groups, corresponding to PPAR α , β , and γ isoforms. Accordingly, the PPAR α from plaice and sea bream is more closely related to one of the two presumed *Fugu* PPAR α (frPPAR α 2 in Fig. 4). Interestingly, the second *Fugu* PPAR α (frPPAR α 1) appears more closely related to the Atlantic

salmon (ss) PPAR α and to the zebrafish PPAR α from chromosome 25 (drchrom25). The second zebrafish PPAR α -like sequence, located on chromosome 4 (drchrom4), is somewhat divergent from the other fish PPAR α and indeed is not reliably placed, based on low bootstrap values for the tree topology. The PPAR β from plaice and sea bream is also closely related to the single PPAR β from *Fugu* as well as to PPAR β 2 from Atlantic salmon. The second Atlantic salmon PPAR β (ssPPAR β 1) as well as the two PPAR β from zebrafish are more distantly related within this cluster and are not reliably placed based on low bootstrap values. As is the case with PPAR β , the plaice and sea bream PPAR γ is closely related to the *Fugu* PPAR γ .

PPAR isotype expression in sea bream and plaice

The tissue expression profile of each of three sea bream PPARs was determined by RNase protection and of plaice by Northern blotting (Fig. 5). For both species, the tissue expression profile was further confirmed by Q-PCR. In sea bream, PPAR α was the major form expressed in liver and heart, and PPAR γ in intestine and adipose tissue. PPAR β transcripts were detected in all sea bream tissues; were more

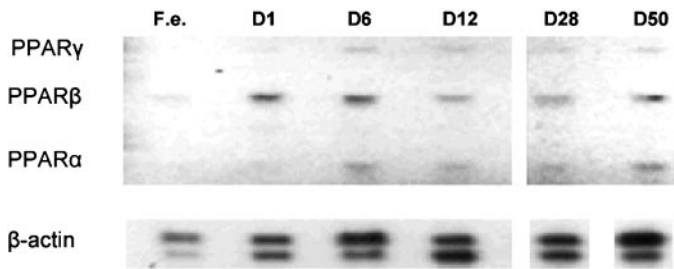

FIG. 6. Expression of PPARs during sea bream development. Total RNA from sea bream fertilized eggs (Fe) and 1-, 6-, 12-, 28-, and 50-d-old larvae (D1-D50) was subjected to RNase treatment in the presence of the riboprobes for the three PPARs and β -actin (see also Fig. 5A). Each lane contains the RNase-protected fragments from 5 μ g of total RNA.

abundant than PPAR α in kidney, spleen, and adipose; and were more abundant than PPAR γ in the brain. In plaice, the PPAR expression profile was generally similar to sea bream. The major differences were the higher level of PPAR β over PPAR α in liver and the low level of PPAR α in red muscle. It is of interest to note that, for both species, the γ -isotype is expressed in all tissues tested at a level at least equal to that of PPAR β . This is in contrast to both mammals and amphibians where this isotype exhibits a restricted expression pattern, being present mainly in adipose tissue, and only at low level in most other tissues (3).

To further examine the similarities or differences in the regulation of PPAR mRNA expression in fish and mammals, the expression of these receptors during sea bream development and in response to fasting was determined.

In rodents, as well as in *Xenopus*, it has been shown that PPARs are differentially expressed during development (25, 26) and thus, we examined the PPAR expression profile in fertilized eggs and sea bream larvae of 1, 6, 12, 28, and 50 d after hatch. As shown in Fig. 6, PPAR β transcripts are detectable even in the fertilized eggs, possibly containing also maternal transcripts and in higher amounts as in d 1 larvae. In addition, PPAR β remains the most abundantly expressed isotype in the body of sea bream larvae for the developmental period examined. The early expression of PPAR β might suggest that this isotype is involved in the mobilization of energy stored in the yolk sac or other critical functions during early development, i.e. differentiation, membrane lipids synthesis and turnover, as these have been proposed for mammals (26, 27). In contrast, PPAR α and PPAR γ expression was only detectable in larvae some time after d 1, but before d 6, i.e. within the period that first feeding occurs in this species. This might indicate a link with the regulation of exogenous energy intake and the progressive differentiation of the organs where these receptors are mainly expressed. All three isotypes appear to maintain a constant level of expression after d 6, although it should be noted that these experiments were

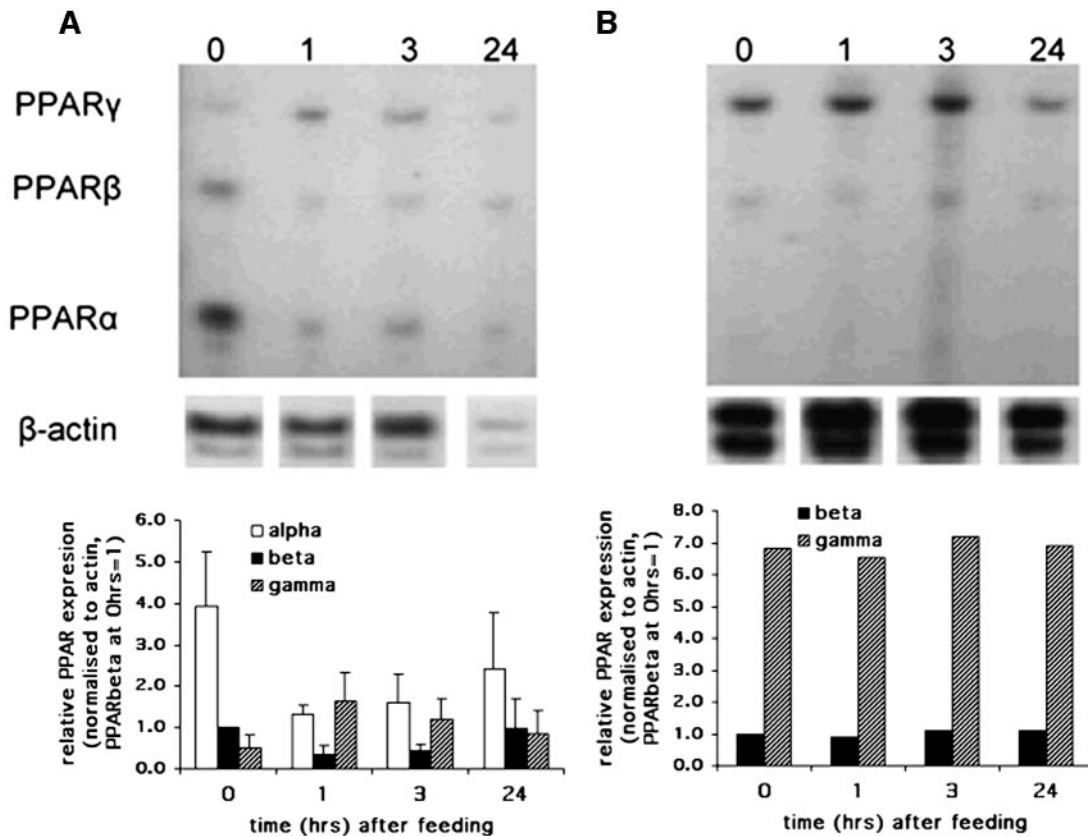

FIG. 7. Effect of nutritional status on PPAR expression in sea bream. A, *Upper panel*: RNase protection of liver total RNA from sea bream fasted for 72 h (0), or 1, 3, and 24 h after feeding. *Lower panel*: Protected signals normalized to β -actin (PPAR β at point 0 = 1). Average values with SD of three independent experiments are given. B, As in panel A but using total intestinal RNA as input. Average values of two independent experiments are given.

TABLE 1. PPREs used in EMSA

PPRE	Sequence
ACO	GACC AGGACA A AGGTCA
Cyp4A6z	AACT AGGGCA A AGTTGA
GSTA1.1	GTAT TGGTCA A GGGTCA
GSTA1.2	TCAA GGGTCA A AGGTCA
GSTA1.3	TGAG TGGTCA A GGATCA
Consensus	AACT <u>AGGNCA</u> A <u>AGGTCA</u>

Alignment of DR1 elements including the 5' flanking sequences. The consensus PPRE is as defined in Ref. 20, and the half-sites of the DR1 are *underlined*.

conducted on whole larvae and no information on tissue-specific expression during these stages is available.

Several recent reports have demonstrated the effect of fasting on PPAR expression in mammalian tissues (3, 28, 29). Thus, the degree to which fish PPARs respond to nutritional modulation was also tested by depriving sea bream of food for 72 h and then allowing feeding to satiation. Fish were removed and RNA was extracted from liver, intestine and adipose tissue at the end of the fasting period, and at 1, 3, and 24 h after feeding. PPAR expression was subsequently assessed by RNase protection. As shown in Fig. 7A, in liver in the fasted state PPAR α is the dominant isotype expressed. At 1 h after feeding, a dramatic decrease in the mRNA level of both PPAR α and β was observed, which was concomitant with an increase in PPAR γ mRNA. The mRNA levels for the three PPAR isotypes in liver gradually returned to approximately initial values at 24 h after feeding. In contrast to the important changes observed in the liver, in intestine or adipose tissue (mesenteral) fasting and refeeding did not influence the sea bream PPAR γ or β expression (Fig. 7B and data not shown). In both adipose and intestine tissues, PPAR α expression was very low and at the limit of detection of the RNase protection assay (see also Fig. 5A). Thus, changes in the expression level of this receptor, if any, could not be calculated.

Binding of fish PPARs to PPREs

The ability of the fish PPARs to recognize and bind to DR1 elements was tested in EMSA with *in vitro*-translated sea bream and plaice PPARs and a variety of PPREs (Table 1). The ACO and the Cyp4A6z elements are well established

PPREs (Ref. 1 and references therein). The GSTA1.1, 1.2, and 1.3 elements correspond to the three DR1-like elements that have been identified in the promoter of the plaice *GSTA1* gene, a gene that has also been shown to be up-regulated by peroxisome proliferators (15).

The three plaice and sea bream PPARs bound efficiently, as heterodimers with the mRXR β , to all PPREs tested (Fig. 8), with the exception of the GSTA1.3 element on which no detectable complexes were observed. In addition, this element was a poor competitor for the EMSA complexes of the other elements tested (data not shown). The nonfunctionality of the GSTA1.3 element in this *in vitro* assay may be due to its significant divergence from the DR1 consensus sequence (Table 1).

In the case of PPAR γ from both species, the presence of the receptor in the EMSA complex was further confirmed with the use of a fish species-specific anti-PPAR γ antibody that we have developed (Fig. 8C).

Similar EMSA behavior of all PPAR isotypes from both species was observed when the human RXR α (not shown) or its plaice ortholog (Leaver, M. J., E. Boukouvala, and G. Krey, unpublished results) were used instead of the mRXR β .

Transactivation

The ability of the fish PPARs to activate transcription was tested in transient expression assays. To ensure efficient interactions of the exogenous PPARs with the endogenous transcriptional apparatus, a cell line from a marine fish species (SBL) was selected to examine the effects of a variety of fatty acids and other compounds on PPAR activity. As shown in Fig. 9, plaice and sea bream PPAR α behaved very similarly and activated transcription in response to all fatty acids tested with the exception of stearic acid. Oleic acid was the most effective naturally occurring activator of this receptor from both species. Also notable is the effect of conjugated linoleic acid (mixed isomers), which was among the most potent PPAR α activators in both species of fish. In plaice, PPAR β was poorly activated by naturally occurring fatty acids. The largest effects were seen with palmitoleic and oleic acids. In sea bream, the effects of fatty acids on this receptor mirrored those seen on plaice PPAR β , although activating to a greater extent.

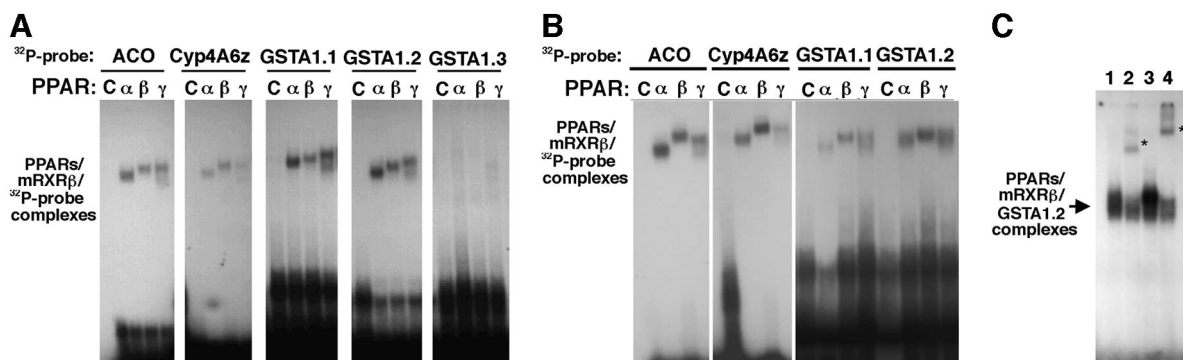
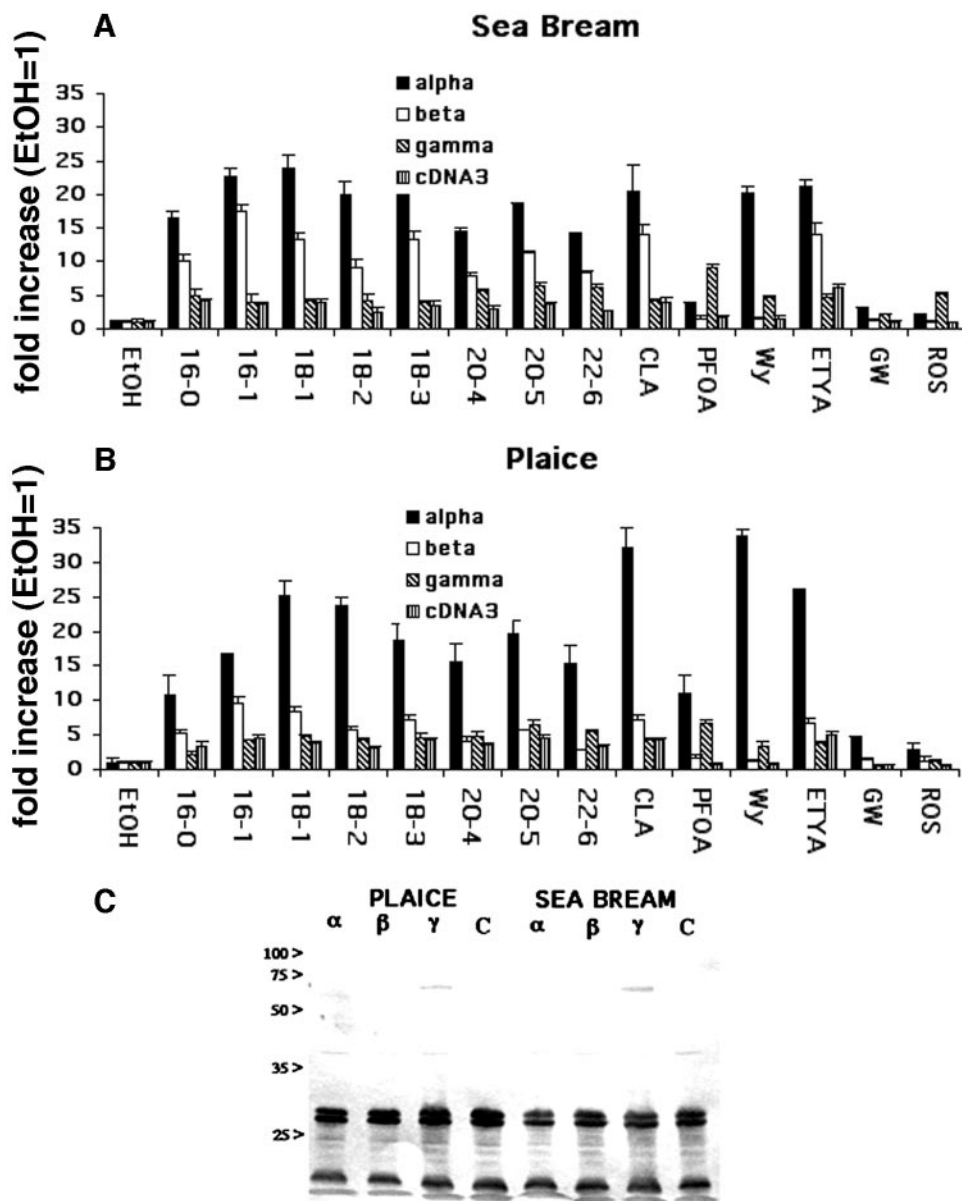

FIG. 8. PPARs from sea bream and plaice bind to various PPREs. **A**, The PPARs (α , β , γ) from sea bream bind to various PPREs. *In vitro*-translated sea bream PPARs and mouse RXR β were incubated with the 32 P-labeled probes as indicated. Lane C is the unprogrammed reticulocyte lysate. **B**, As in Panel A but using the plaice PPARs. **C**, PPAR γ -specific antibody supershifts the PPAR γ /mRXR β /GSTA1.2 complex. *In vitro*-translated sea bream (lanes 1 and 2) and plaice (lanes 3 and 4) PPAR γ was incubated with mRXR β and the 32 P-labeled GSTA1.2 probe in the presence of either preimmune serum (lanes 1 and 3) or PPAR γ -specific antibody (lanes 2 and 4). Supershifted complexes are indicated by *asterisks*.

FIG. 9. Transactivation of sea bream and plaice PPARs. A, Sea bass larval cells were transfected with the expression vector pcDNA3, alone (cDNA3) or containing the coding sequences for the three sea bream PPARs, a CAT reporter construct containing the Cyp4A6z PPRE and a β -galactosidase expression plasmid. Cells were treated with 100 μ M (unless otherwise indicated) palmitic acid (16-0), palmitoleic acid (16-1), oleic acid (18-1), linoleic acid (18-2), linolenic acid (18-3), arachidonic acid (20-4), eicosapentenoic acid (20-5), docosahexenoic acid (22-6), mixed isomers of CLA, Wy-14,643 (WY, 50 μ M), PFOA, rosiglitazone (ROS, 10 μ M), GW1929 (GW, 10 μ M) or ETYA (10 μ M). Results are expressed as the fold increase in CAT (after subtraction of mock transfected background and normalization to β -galactosidase) with respect to the ethanol control. Figures represent a single experiment out of two repetitions and all treatments were in triplicate. Error bars correspond to SD of the mean. B, As in panel A but using the plaice PPARs. C, PPAR γ from both sea bream and plaice is expressed in transfected cells. Lysates from SBL cells transfected with the fish PPARs (α , β , and γ) were resolved by SDS-PAGE, blotted, and visualized with PPAR γ -specific antibody. The positions of protein molecular size markers (in kilodaltons) are indicated. Only cells transfected with PPAR γ show cross-reacting proteins of the predicted molecular size (~60 kDa).



Interestingly, in the presence of PPAR γ from either fish species, none of the saturated or monounsaturated fatty acids tested were able to significantly activate transcription from the reporter construct used in this assay. However, the highly unsaturated arachidonic, eicosapentenoic, and docosahexenoic acids were capable of activating this isotype, albeit at a low level and only in sea bream.

Of the synthetic compounds tested, the mammalian PPAR α -specific ligand, Wy-16,463, was an efficient and specific activator of PPAR α in both plaice and sea bream. ETYA was specific and effective for PPAR α in plaice and in sea bream also appeared to have effects on PPAR β . Perfluorooctanoic acid (PFOA) was capable of activating PPAR α in both species, albeit to a lesser extent than most of the other effectors. However, of all the presumptive ligands tested, PFOA elicited the highest response from PPAR γ . In contrast, rosiglitazone, a specific and high af-

finity mammalian PPAR γ ligand (Ref. 1 and references therein), produced only low levels of activation with fish PPAR γ . GW1929, a highly effective and specific nonthiazolidinedione mammalian PPAR γ ligand (30), had no effect on plaice or sea bream PPAR γ . Identical transactivation results were obtained when the PPAR γ was transfected in a different fish-derived cell line, the Atlantic salmon AS cell line (not shown), suggesting that the relative inactivity of the receptor in the SBL cells was not likely to be due to the lack of essential factors, such as PPAR γ -specific coactivators. Furthermore, we excluded the possibility that PPAR γ was not expressed in transfected cells by using the fish PPAR γ -specific antibody. Cross-reacting protein of the predicted molecular size was found only in PPAR γ -transfected cells and not in cells transfected with PPAR α or β or in mock-transfected cells (Fig. 9C). Thus, we conclude that the absence of activation

with the mammalian PPAR γ ligands was due to intrinsic structural properties of the fish receptor and not due to inefficient expression of PPAR γ in transfected cells.

Of interest to note is that basal expression from the reporter construct was increased in the presence of all natural fish PPAR activators and especially of ETYA indicating that an endogenous factor(s) is active in the SBL cell line. The activation profile observed with the compounds tested in the presence of the three PPAR isotypes and in particular the specificity of Wy-14,643 for PPAR α suggests that this effect may be exerted through a PPAR β homolog.

Discussion

Piscine PPARs

We have isolated PPAR genes and corresponding cDNAs from plaice and sea bream, the first report of three complete PPAR isotypes from any fish species. However, whether there may be other PPAR genes in the genomes of these fish remains unclear. Database mining of the *Fugu* and zebrafish genomes applied by others (14) and in this work, suggests the presence of more than three PPARs in these species. Thus, *Fugu* harbors two distinct PPAR α genes and zebrafish two genes for each of PPAR α and PPAR β . Furthermore, as previously stated, we have also identified two distinct PPAR β genes in Atlantic salmon. In contrast, there is presently no evidence of more than one PPAR γ gene in any fish species.

According to our phylogenetic analysis, it seems likely that a further PPAR α gene may be present in plaice and sea bream and indeed in Atlantic salmon. This assumption is based on the fact that the deduced LBD sequence of one of the *Fugu* PPAR α genes is more closely related to the plaice and sea bream PPAR α . In contrast, the second *Fugu* PPAR α is more related to a PPAR α we have identified from Atlantic salmon and to the presumed PPAR α gene located on the zebrafish chromosome 25. The PPAR β gene we identified in plaice and sea bream is closely related to the unique PPAR β gene from *Fugu*. *Fugu*, plaice, and sea bream belong to the same evolutionary line, the *Percomorpha*, and it is therefore probable that there is only a single PPAR β gene in these species. In contrast, both zebrafish and salmon, belonging to the *Cypriniformes* and *Salmoniformes*, respectively, contain two distinct PPAR β genes (Ref. 13 and our own results), which could have arisen independently within these two evolutionary lines. A single PPAR γ gene has also been identified in the *Fugu* genome (14) closely related to the plaice and sea bream PPAR γ . Apparently, a single PPAR γ gene is also present in zebrafish, on chromosome 11. Thus, it appears that the number of PPAR genes can vary within fish species, especially concerning the number of PPAR β genes. However, it should be noted that it is not possible with any confidence to predict entire PPAR sequences from genome data, nor to conclude on the functionality of the presumed genes without complete cDNA analyses. Thus, to date this report on plaice and sea bream represents the first complete sequence and functional data for three PPAR isotypes from any fish species. Furthermore, it is clear that in both plaice and sea bream, as well in the other fish species discussed above, defined homologs of mammalian PPAR α , β , and γ exist, suggesting that PPARs diverged from an ancestral gene before the evolutionary divergence of fish and mammalian lines.

Structural features of piscine PPARs

Not unexpectedly, in the proteins encoded by the above genes, the greatest degree of identity among the plaice and sea bream PPARs with PPARs from other species is found within the DNA binding or C-domain. Within the core of this domain, *i.e.* the two zinc fingers, piscine PPARs share approximately 90% identical residues with their mammalian counterparts. In addition, the feature that distinguishes PPARs from the other members of the NHR, *i.e.* a D-box of three instead of five amino acids, is maintained in the fish receptors. Our results have demonstrated that fish PPARs, like their mammalian homologs, heterodimerize with RXR and bind to DR1 elements of both mammalian and piscine genes indicating that the DNA binding properties of the C-domain of these receptors are conserved in the lower vertebrates. Thus, it is likely that PPAR-dependent transcriptional activation in fish involves very similar promoter structural requirements as in mammals.

The LBDs of the fish PPARs also exhibit significant identity to PPARs from other species, although the LBDs of the fish α - and γ -isotypes are longer due to an extra 21-amino acid residues in sea bream and plaice PPAR α and an extra 23- and 35-amino acid residues in the sea bream and plaice PPAR γ , respectively. Interestingly, these residue insertions all occur in an area that, in the mammalian PPARs, is unique among nuclear receptors in forming an extrahydrophilic α -helix and a loop, together forming a structure suggested to influence access to the ligand binding pocket (31–34). In the plaice and sea bream PPAR γ and indeed PPAR α , this structure might be expected to be considerably larger and more hydrophilic than its mammalian counterpart with possible implications for ligand binding.

When comparing the fish and mammalian PPAR isotypes, the least conserved region is the A/B domain, which in fish appears to be considerably longer. In mammals, this domain has been shown to participate in ligand-independent modulation of PPAR activity via phosphorylation (35) and by binding coactivator proteins (36). Interestingly, in both PPAR α and γ , the net negative charge of this domain observed in the mammalian receptors is also conserved in the piscine ones. In the mammalian PPAR β , this domain is only 42 residues long and negatively charged due to the presence of 13 glutamate residues. The high content of charged residues (42% of total) and the net negative charge of this domain are also maintained in the sea bream β receptor. In contrast, the plaice PPAR β A/B domain, although also rich in charged residues (39% of total), has a considerably less negative net charge.

Finally, concerning the D domain, it is interesting to note that its length is absolutely conserved among PPAR β and γ from different phyla (68 and 67 amino acid residues, respectively), whereas in the α -isotype it is one residue shorter in the fish receptors when compared with mammals (67 *vs.* 68 amino acids).

Functional characterization of the piscine PPARs

Taken together, all our data suggest that the plaice and sea bream PPAR α isotype broadly resembles PPAR α from other vertebrates. The role of PPAR α is hypothesized to be primarily in controlling the reversible induction of β -oxidation in specific tissues as a response to changing energy requirements and nutritional status. The evidence for this comes most directly from rodents where PPAR α -null mice show dramatic inhibition

of fatty acid oxidation during fasting (28, 29). Fasting has also been shown to up-regulate the expression of PPAR α in liver and intestine of normal animals (3, 28, 29). Mammalian PPAR α is strongly activated by various naturally occurring fatty acids, and by synthetic compounds (5–7), and these fatty acids and other compounds can act as *bona fide* ligands for the receptor (34). Like its mammalian homolog, plaice and sea bream PPAR α is most highly expressed in tissues with high β -oxidation capacity, namely liver, heart, and, in sea bream, red muscle. Also similar to mammals, the mRNA expression level of PPAR α is increased in the livers of fasted sea bream. Importantly, the transactivation profile of plaice and sea bream PPAR α is highly similar to that reported for PPAR α in mammals (5, 6). Thus, the fish PPAR α is strongly activated by a range of unsaturated fatty acids and by Wy-14,643, a specific mammalian PPAR α ligand. Also notable is the efficient transactivation of the fish receptor by CLA, a compound shown to activate all mammalian PPAR isotypes (37, 38).

Similar to PPAR α , PPAR β from both plaice and sea bream share features with mammalian PPAR β . In rodents, PPAR β appears to be ubiquitously expressed and often at much higher levels than PPAR α or γ (3). Similarly, in plaice and sea bream, PPAR β is expressed in all tissues tested and appears to be the first isotype expressed during development in fish as is also the case in amphibians and mammals (25, 26, 39).

Moreover, PPAR β is also activated by naturally occurring fatty acids, albeit to a lesser extent than PPAR α , a similar situation to that reported for PPAR β from mammals and amphibians (5, 19). The wide tissue distribution and broad fatty acid transactivation potential of PPAR β has recently led to the proposal that this isotype functions as a widespread regulator of fat burning in mammals (40). Our results with plaice and sea bream PPARs would support this contention. Notably, however, and unlike rodents, PPAR β expression in sea bream liver follows a pattern similar to that of PPAR α upon fasting and re-feeding, *i.e.* it is induced in the fasted state and decreased following feeding, whereas in rodents is down-regulated in the fasted state (3). The potential for different mechanisms to regulate expression of PPAR isotypes in fish and mammals is further underscored by the fact that neither PPAR β nor γ expression in intestine or adipose tissue was affected by nutritional status in sea bream. In contrast, in both mice and rats, fasting provokes a substantial decrease of PPAR γ 1 and γ 2 expression in adipose tissue (3, 41).

Plaice and sea bream PPAR γ , unlike either PPAR α or PPAR β from these species, shows significant differences from its mammalian counterpart. PPAR γ , in mammals, is considered to play a critical role in fat accumulation particularly in adipocytes, but also in monocytes in certain conditions (42). Thus, rodent PPAR γ is predominantly expressed in adipose tissue, and parts of the immune system, particularly monocytes and macrophages, being expressed to high level in spleen for example (3). In contrast, the fish species express this isotype in a wider range of tissues than mammals, with similar or greater levels than PPAR β in most tissues. Furthermore, as mentioned above, the sea bream PPAR γ , in contrast to mammalian PPAR γ , is not under nutritional control in adipocytes. Other differences between fish and mammalian PPAR γ are also evident. Saturated and monounsaturated fatty acids were not effective in PPAR γ transactivation experiments, whereas mammalian PPAR γ is

effectively activated by monounsaturates (6). Also, the highly selective and potent mammalian PPAR γ agonists rosiglitazone and GW1929 (30, 31) were poor or ineffective activators of this isotype in fish. These differences might be explained from closer consideration of the structure of the piscine PPAR γ ligand binding domain. Of the three residues of human PPAR γ that are most important for hydrogen-bonding with the acidic head-group of PPAR ligands, and which are conserved in all mammalian, avian, and amphibian PPARs sequenced to date, *i.e.* H323, H449, and Y473 (31–34), only the equivalent residue to H449 is present in the plaice and sea bream PPAR γ proteins. The equivalent to H323 is replaced by isoleucine and Y473 by methionine (Fig. 2). These differences also exist in Atlantic salmon PPAR γ and in *Fugu* (12, 14) and so are unlikely to be experimental artifacts. Such residue substitutions could significantly affect the ligand binding characteristics of fish PPAR γ , as our results suggest. However, to our knowledge no natural or artificially introduced substitutions at these positions have been reported in the mammalian PPAR γ , and thus the specific contribution of these residues in ligand binding remains to be determined. In addition, as discussed above, it is possible that the structure of peptide regions suggested to be important in influencing ligand access to the binding pocket may be significantly different in the piscine PPAR γ isotype.

As previously argued, we consider it unlikely that fish species contain a second PPAR γ gene corresponding more closely to the mammalian receptor. Therefore, it is of great interest, given the critical roles PPAR γ plays in mammals, that the piscine receptor is so specifically divergent in both expression pattern and ligand binding. This divergence may be a reflection of the significant differences in the physiology of these species. In mammals, selective PPAR γ ligands have beneficial effects on insulin resistance during type II diabetes, and these effects are believed to primarily involve direct action on adipocytes to promote uptake of lipid and thereby to switch glucose utilization in distant tissues. In addition, PPAR γ ligand-treated adipocytes release a number of peptides and proteins that have modulatory activities on insulin sensitivity in other tissues (42). In this regard, it is important to note that most marine fish are inefficient in carbohydrate absorption and incapable of regulating blood glucose levels, displaying an apparent tissue insensitivity to glucose (43, 44).

Fish are the most diverse group of all the vertebrates and exhibit a bewildering array of life and reproductive strategies, and it may be that fish species have used PPARs in different ways to terrestrial vertebrates. Further study of PPAR function in fish may indicate pathways that are common to critical processes in both fish and mammals, providing additional focus for research in important human diseases.

Acknowledgments

We thank the reviewers for useful comments and Walter Wahli for plasmids and critical reading of the manuscript. We also thank Susana Perez-Benavente for excellent technical assistance with the Q-PCR, RNA analysis, and antibody production.

Received December 20, 2004. Accepted March 14, 2005.

Address all correspondence and requests for reprints to: Grigorios Krey, National Agricultural Research Foundation, Fisheries Research Institute, Nea Peramos, 64007 Kavala, Greece. E-mail: krey@otenet.gr.

This work was supported by the European Commission (Project Number Q5RS-2000–30360) and the Biotechnology and Biological Sciences Research Council (UK). All sequences described herein have been deposited in the EMBL/GenBank databases under accession nos. AJ539467, AJ539468, AJ539469, AY590299, AY590301, AY590304.

Present address for E.A.: Department of Biology, Laboratory of Physiology, Aristotle University of Thessaloniki, 54124 Thessaloniki, Greece.

References

- Desvergne B, Wahli W 1999 Peroxisome proliferator-activated receptors: nuclear control of metabolism. *Endocr Rev* 20:649–688
- Hihl AK, Michalik L, Wahli W 2002 PPARs: transcriptional effectors of fatty acids and their derivatives. *Cell Mol Life Sci* 59:790–798
- Escher P, Braissant O, Basu-Modak S, Michalik L, Wahli W, Desvergne B 2001 Rat PPARs; quantitative analysis in adult rat tissues and regulation in fasting and refeeding. *Endocrinology* 142:4195–4202
- Isseman I, Green S 1990 Activation of a member of the steroid hormone receptor superfamily by peroxisome proliferators. *Nature* 347:645–650
- Forman BM, Chen J, Evans RM 1997 Hypolipidemic drugs, polyunsaturated fatty acids, and eicosanoids are ligands for peroxisome proliferator-activated receptors α and δ . *Proc Natl Acad Sci USA* 94:4312–4317
- Kliwer SA, Sundseth SS, Jones SA, Brown PJ, Wisely GB, Koble CS, Devchand P, Wahli W, Willson TM, Lenhard JM, Lehmann JM 1997 Fatty acids and eicosanoids regulate gene expression through direct interactions with peroxisome proliferator-activated receptors α and γ . *Proc Natl Acad Sci USA* 94:4318–4323
- Krey G, Braissant O, L'Horsset F, Kalkhoven E, Perroud M, Parker MG, Wahli W 1997 Fatty acids, eicosanoids, and hypolipidemic agents identified as ligands of peroxisome proliferator-activated receptors by coactivator-dependent receptor ligand assay. *Mol Endocrinol* 11:779–791
- Kliwer SA, Umeson K, Noonan DJ, Heyman RA, Evans RM 1992 Convergence of 9-*cis* retinoic acid and peroxisome proliferator signalling pathways through heterodimer formation of their receptors. *Nature* 358:771–774
- Keller H, Dreyer C, Medin J, Mahfoudi A, Ozato K, Wahli W 1993 Fatty acids and retinoids control lipid metabolism through activation of peroxisome proliferator-activated receptor-retinoid X receptor heterodimers. *Proc Natl Acad Sci USA* 90:2160–2164
- Xu L, Glass CK, Rosenfeld MG 1999 Coactivator and corepressor complexes in nuclear receptor function. *Curr Opin Genet Dev* 9:140–147
- Michalik M, Wahli W 1999 Peroxisomal proliferator-activated receptors: three isotypes for a multitude of functions. *Curr Opin Biotech* 10:564–570
- Andersen O, Eijssink VGH, Thomassen M 2000 Multiple variants of the peroxisomal proliferator-activated receptor, PPAR γ are expressed in the liver of Atlantic salmon (*Salmo salar*). *Gene* 255:411–418
- Robinson-Rechavi M, Marchand O, Escriva H, Bardet PL, Zelus D, Hughes S, Laudet V 2001 Euteleost fish genomes are characterised by expansion of gene families. *Genome Res* 11:781–788
- Maglich JM, Caravella JA, Lambert MH, Willson TM, Moore JT, Ramamurthy L 2003 The first completed genome sequence from a teleost fish (*Fugu rubripes*) adds significant diversity to the nuclear receptor superfamily. *Nucleic Acids Res* 31:4051–4058
- Leaver MJ, Wright J, George SG 1997 Structure and expression of a cluster of glutathione S-transferase genes from a marine fish, the plaice (*Pleuronectes platessa*). *Biochem J* 321:405–412
- Leaver MJ, Wright J, George SG 1998 A peroxisomal proliferator-activated receptor gene from the marine flatfish, the plaice (*Pleuronectes platessa*). *Mar Environ Res* 46:75–79
- Thompson JD, Higgins DG, Gibson TJ 1994 CLUSTAL W: improving the sensitivity of progressive multiple sequence alignment through sequence weighting, positions-specific gap penalties and weight matrix choice. *Nucleic Acids Res* 22:4673–4680
- Saitou N, Nei M 1987 The neighbour-joining method—a new method for reconstructing phylogenetic trees. *Mol Biol Evol* 4:406–425
- Krey G, Keller H, Mahfoudi A, Medin J, Ozato K, Dreyer C, Wahli W 1993 Xenopus peroxisome proliferator activated receptors: genomic organisation, response element recognition, heterodimer formation with retinoid X receptor and activation by fatty acids. *J Steroid Biochem Mol Biol* 47:65–73
- Ijpenberg A, Jeannin E, Wahli W, Desvergne B 1997 Polarity and specific sequence requirements of peroxisome proliferator-activated receptor (PPAR)/retinoid X receptor (RXR) heterodimer binding to DNA. A functional analysis of the malic enzyme gene PPAR response element. *J Biol Chem* 274:15901–20117
- Tugwood JD, Isseman I, Anderson RG, Bundell KR, McPheat WL, Green S 1992 The mouse peroxisome proliferator activated receptor recognizes a response element in the 5' flanking sequence of the rat acyl CoA oxidase gene. *EMBO J* 11:433–439
- Ohno S, Atkin NB 1966 Comparative DNA values and chromosome complements of eight species of fishes. *Chromosoma* 18:455–466
- Leaver MJ 2001 A family of Tc1-like transposons from the genomes of fishes and frogs: evidence for horizontal transmission. *Gene* 271:203–214
- Zhu Y, Qi C, Korenberg JR, Chen XN, Noya D, Rao MS, Reddy JK 1995 Structural organization of mouse peroxisome proliferator-activated receptor γ , mPPAR γ gene: alternative promoter use and different splicing yield two mPPAR isoforms. *Proc Natl Acad Sci USA* 92:7921–7925
- Dreyer C, Krey G, Keller H, Givel F, Helftenbein G, Wahli W 1992 Control of the peroxisomal β -oxidation pathway by a novel family of nuclear hormone receptors. *Cell* 68:879–887
- Braissant O, Wahli W 1998 Differential expression of peroxisome proliferator-activated receptor- α , - β and - γ during rat embryonic development. *Endocrinology* 139:2748–2754
- Barak Y, Liao D, He WM, Ong ES, Nelson MC, Olefsky JM, Boland R, Evans RM 2002 Effects of peroxisome proliferator-activated receptor delta on placenta, adiposity, and colorectal cancer. *Proc Natl Acad Sci USA* 99:303–308
- Kersten S, Seydoux J, Peters JM, Gonzalez FJ, Desvergne B, Wahli W 1999 Peroxisome proliferator-activated receptor α mediates the adaptive response to fasting. *J Clin Invest* 103:1489–1498
- Leone TC, Weinheimer CJ, Kelly DP 1999 A critical role for the peroxisome proliferator-activated receptor α (PPAR α) in the cellular fasting response: the PPAR α -null mouse as a model of fatty acid oxidation disorders. *Proc Natl Acad Sci USA* 96:7473–7478
- Henke BR, Blanchard SG, Brackeen MF, Brown KK, Cobb JE, Collins JL, Harrington Jr WW, Hashim MA, Hull-Ryde EA, Kaldor I, Kliwer SA, Lake DH, Leesnitzer LM, Lehmann JM, Lenhard JM, Orband-Miller LA, Miller JF, Mook Jr RA, Noble SA, Oliver Jr W, Parks DJ, Plunket KD, Szweczyk JR, Willson TM 1998 N-(2-benzoylphenyl)-L-tyrosine PPAR agonists. 1. Discovery of a novel series of potent antihyperglycemic and antihyperlipidemic agents. *J Med Chem* 41:5020–5036
- Uppenberg J, Svensson C, Jaki M, Bertilsson G, Jendeborg L, Berkenstam A 1998 Crystal structure of the ligand binding domain of the human nuclear receptor PPAR γ . *J Biol Chem* 273:31108–31112
- Nolte RT, Wisely GB, Westin S, Cobb JE, Lambert MH, Kurokawa R, Rosenfeld MG, Willson TM, Glass CK, Milburn MV 1998 Ligand binding and co-activator assembly of the peroxisome proliferator-activated receptor- γ . *Nature* 395:137–143
- Xu HE, Lambert MH, Montana VG, Plunket KD, Moore LB, Collins JL, Oplinger JA, Kliwer SA, Gampe Jr RT, McKee DD, Moore JT, Willson TM 2001 Structural determinants of ligand binding selectivity between the peroxisome proliferator-activated receptors. *Proc Natl Acad Sci USA* 98:13919–13929
- Xu HE, Lambert MH, Montana VG, Parks DJ, Blanchard SG, Brown PJ, Sternbach DD, Lehmann JM, Wisely GB, Willson TM, Milburn MV 1999 Molecular recognition of fatty acids by peroxisome proliferator-activated receptors. *Mol Cell* 3:397–403
- Adams M, Reginato MJ, Shao DL, Lazar MA, Chatterjee VK 1997 Transcriptional activation by peroxisome proliferator-activated receptor γ is inhibited by phosphorylation at a consensus mitogen-activated protein kinase site. *J Biol Chem* 272:5128–5132
- Gelman L, Zhou G, Fajas L, Raspé E, Fruchart JC, Auwerx J 1999 p300 Interacts with the N- and C-terminal part of PPAR γ 2 in a ligand-independent and ligand-dependent manner, respectively. *J Biol Chem* 274:7681–7688
- Moya-Camarena SY, Vanden Heuvel JP, Blanchard SG, Leesnitzer L, Belury MA 1999 Conjugated linoleic acid is a high affinity, naturally occurring ligand that activates PPAR α . *J Lipid Res* 40:1426–1433
- Belury MA, Moya-Camarena SY, Lu M, Shi L, Leesnitzer LM, Blanchard SG 2002 Conjugated linoleic acid is an activator and ligand for peroxisome proliferator-activated receptor- γ (PPAR γ). *Nutr Res* 22:817–824
- Dreyer C, Keller H, Mahfoudi A, Laudet V, Krey G, Wahli W 1993 Positive regulation of the peroxisomal β -oxidation pathway by fatty acids through activation of peroxisome proliferator-activated receptors (PPAR). *Biol Cell* 77:67–76
- Wang YX, Lee CH, Tjep S, Yu RT, Ham J, Kang H, Evans RM 2003 Peroxisome proliferator-activated receptor δ activates fat metabolism to prevent obesity. *Cell* 113:159–170
- Vidal-Puig A, Jimenez-Liñan M, Lowell BB, Hamann A, Hu E, Spiegelman B, Flier JS, Moller DE 1996 Regulation of PPAR γ gene expression by nutrition and obesity in rodents. *J Clin Invest* 97:2553–2561
- Rosen ED, Spiegelman BM 2001 PPAR γ : a nuclear regulator of metabolism, differentiation, and growth. *J Biol Chem* 276:37731–37734
- Hemre G-I, Mommensen TP, Kroghdal A 2002 Carbohydrates in fish nutrition: effects on growth, glucose metabolism and hepatic enzymes. *Aquacult Nutr* 8:175–194
- Moon TW 2001 Glucose intolerance in teleost fish: fact or fiction? *Comp Biochem Physiol B* 129:243–249