

Thyroid Hormone Replacement Therapy: Three ‘Simple’ Questions, Complex Answers

Antonio C. Bianco · Sabina Casula

Division of Endocrinology, Diabetes and Metabolism, University of Miami Miller School of Medicine, Miami, Fla., USA

Key Words

Hypothyroidism · Thyroid hormone · Deiodination ·
Combined therapy · Levothyroxine · Liothyronine ·
Gene polymorphism · Desiccated thyroid

Abstract

Current guidelines recommend that hypothyroid patients should be treated with levothyroxine, which in the vast majority of the cases leads to resolution of the symptoms and normalization of serum free T_4 (FT_4), T_3 and TSH levels. However, a small group of hypothyroid patients remain symptomatic for neurocognitive dysfunction despite normal serum FT_4 and TSH, which could be explained by localized brain hypothyroidism. More than half of the T_3 in the brain is produced locally via the action of the type II deiodinase (D_2) and variability/defects in this pathway could explain the residual symptoms. If this rationale is correct, adding liothyronine to the replacement therapy could prove beneficial. However, with a few exceptions, several clinical trials failed to identify any beneficial effects of combined therapy. More recently, the results of a large clinical trial revealed a better neurocognitive outcome with combined therapy only in hypothyroid patients carrying a polymorphism in the $DIO2$ gene. This obviously needs to be confirmed by other groups but it is tempting to speculate that combined levothyroxine and liothyronine has a place in the treatment of hypothyroidism, for some.

Copyright © 2012 European Thyroid Association
Published by S. Karger AG, Basel

Hypothyroidism affects about 3.7% of the general population in the United States [1], reaching levels of up to 8% in areas with high prevalence of iodine deficiency [2]. At first sight, treatment for hypothyroidism, regardless of its etiology, seems quite straightforward. According to current guidelines the standard of care is treatment based on hormonal replacement therapy with daily administration of levothyroxine, the pro-hormone produced exclusively by the thyroid gland [3]. The rationale is that the deiodinases, thioredoxin-fold containing selenoenzymes that metabolize thyroid hormone and are present in multiple extrathyroidal tissues, activate thyroxine (T_4) and produce physiological amounts of the biologically active thyroid hormone, triiodothyronine (T_3) [4]. The observation that circulating levels of T_3 and TSH can be normalized in levothyroxine-treated hypothyroid patients reassures physicians that euthyroidism is achieved and probably contributed for the replacement of porcine thyroid preparations by the synthetic form of levothyroxine currently used [5, 6]. In fact, monitoring serum levels of TSH (and free T_4 (FT_4)) became an integral part of the routine to follow the therapeutic efficacy of thyroid hormone replacement. However, despite normalization of these biochemical parameters, about 15% of those treated with levothyroxine replacement therapy alone do not achieve clinical euthyroidism and experience some level of psychological impairment [7].

KARGER

Fax +41 61 306 12 34
E-Mail karger@karger.ch
www.karger.com

© 2012 European Thyroid Association
Published by S. Karger AG, Basel
2235–0640/12/0012–0088\$38.00/0
Accessible online at:
www.karger.com/etj

Dr. Antonio C. Bianco
University of Miami Miller School of Medicine
1400 N.W. 10th Avenue, Suite 601
Miami, FL 33136 (USA)
Tel. +1 305 243 5631, E-Mail abianco@med.miami.edu

The persistency of a relatively small number of clinically symptomatic patients has led to an explosion of alternative treatment strategies, including the reawakening of desiccated porcine thyroid and development of new 'thyroid supplements' that take advantage of regulatory loopholes to avoid governmental oversight. This has created greater awareness in the medical community, with concerns gravitating mostly around two areas, namely (i) defining what is missing in our understanding of thyroid hormone signaling (transport across cell membranes and metabolism) that prevents us from developing a treatment strategy that is effective for 100% of the patients, and (ii) preventing the widespread usage of 'thyroid formulas' that in many cases leads to long-term subclinical or clinical thyrotoxicosis and their well-known consequences.

Basic Principles of Thyroid Hormone Transport, Metabolism and Action

T₃ enters the target cells through a few specific thyroid hormone transporters, including monocarboxylate transporter (MCT)8, MCT10, and organic anion-transporting polypeptide 1C1 (OATP) [8]. Once inside the cells, T₃ gains access to the cell nucleus where it interacts with two forms of nuclear receptors (TR α and TR β); both TRs are unevenly distributed throughout the body, with virtually every cell expressing either one or both receptors. This modulates the expression of specific sets of T₃-responsive genes, thus producing T₃-dependent biological effects, e.g. positive cardiac chronotropism, bone resorption, acceleration of energy expenditure [9–11] (fig. 1).

In healthy adult individuals, about 80–90% of the extrathyroidal T₃ is produced by deiodination of T₄ via the type I (D₁) and type II (D₂) deiodinases [12, 13], which are widely expressed throughout extrathyroidal organs and tissues: D₁, in liver and kidney, and D₂, in the central nervous system, bone, skin, pituitary gland, brown adipose tissue and in minute amounts in skeletal muscle and heart [14, 15]. Thus, there are two sources of T₃ bound to tissue TR at any given time, i.e. (i) direct thyroid secretion or (ii) extrathyroidal deiodination of T₄ [14, 16]. There is also a third deiodinase, D₃, which can inactivate both T₄ and T₃ and is expressed mostly during embryonic life [17]; in healthy adults, D₃ expression remains only in a handful of tissues, including brain, skin, heart and pancreatic β -cells [14, 18]. However, during disease processes, D₃ expression can be enhanced severalfold or ectopi-

cally activated in most tissues, including liver, skeletal muscle and heart via signals such as ischemia and/or hypoxia [19, 20].

The First Question: Can Plasma and Tissue T₃ Concentrations Be Normalized in Levothyroxine-Treated Hypothyroid Individuals?

Serum T₃ concentrations are expected to be normal in levothyroxine-treated hypothyroid individuals [21–23]. This would indicate that the deiodinase pathways are sufficient to normalize T₃ levels in the plasma, provided that enough T₄ is available. However, a recent large-scale cross-sectional study involving about 3,900 euthyroid volunteers and about 1,800 athyreotic patients kept on replacement therapy with levothyroxine indicates that serum T₃ is consistently lower in the hypothyroid patients, although within the normal range [24]. Furthermore, in approximately 15% of these hypothyroid patients, serum T₃ is not normalized despite normal serum TSH [24]. In addition, it seems that further increases in the dose of levothyroxine would not result in normalization of serum T₃ without bringing serum TSH below the normal range. Of note, when all individuals are stratified as a function of their serum TSH, it is clear that for any given serum TSH, the levothyroxine-treated hypothyroid patients exhibit significantly lower serum T₃ [24].

One additional point to keep in mind is that, as opposed to T₄, T₃ is mostly an intracellular hormone [14, 25]. Yes, it is true that plasma and tissue T₃ are at equilibrium at all times, but the sizes of both pools are not the same [14] and both T₃ production and T₃ degradation are intracellular events [26, 27]. Deiodinase-mediated T₃ production takes place inside the T₃-target cells and thus in any given cell there is a chance that the TR-bound T₃ was produced locally (within that very same cell) and found its way to the cell nucleus before exiting the cell or reaching the plasma (fig. 2). The odds of this happening vary from tissue to tissue and depend among other things on the local activity of the deiodinases. At the same time, D₃-mediated T₂ inactivation also takes place inside the cells and thus some of the T₃ produced intracellularly might be degraded before reaching the plasma [27].

Thus, plasma T₃ level is a poor predictor of tissue T₃ concentration because it does not account for the intracellular production/inactivation of T₃ via the deiodinase pathways. As a consequence, a normal serum T₃ does not mean that the T₃ content in all tissues is normal. In fact, a mouse with targeted inactivation of D₂ (D₂KO) has nor-

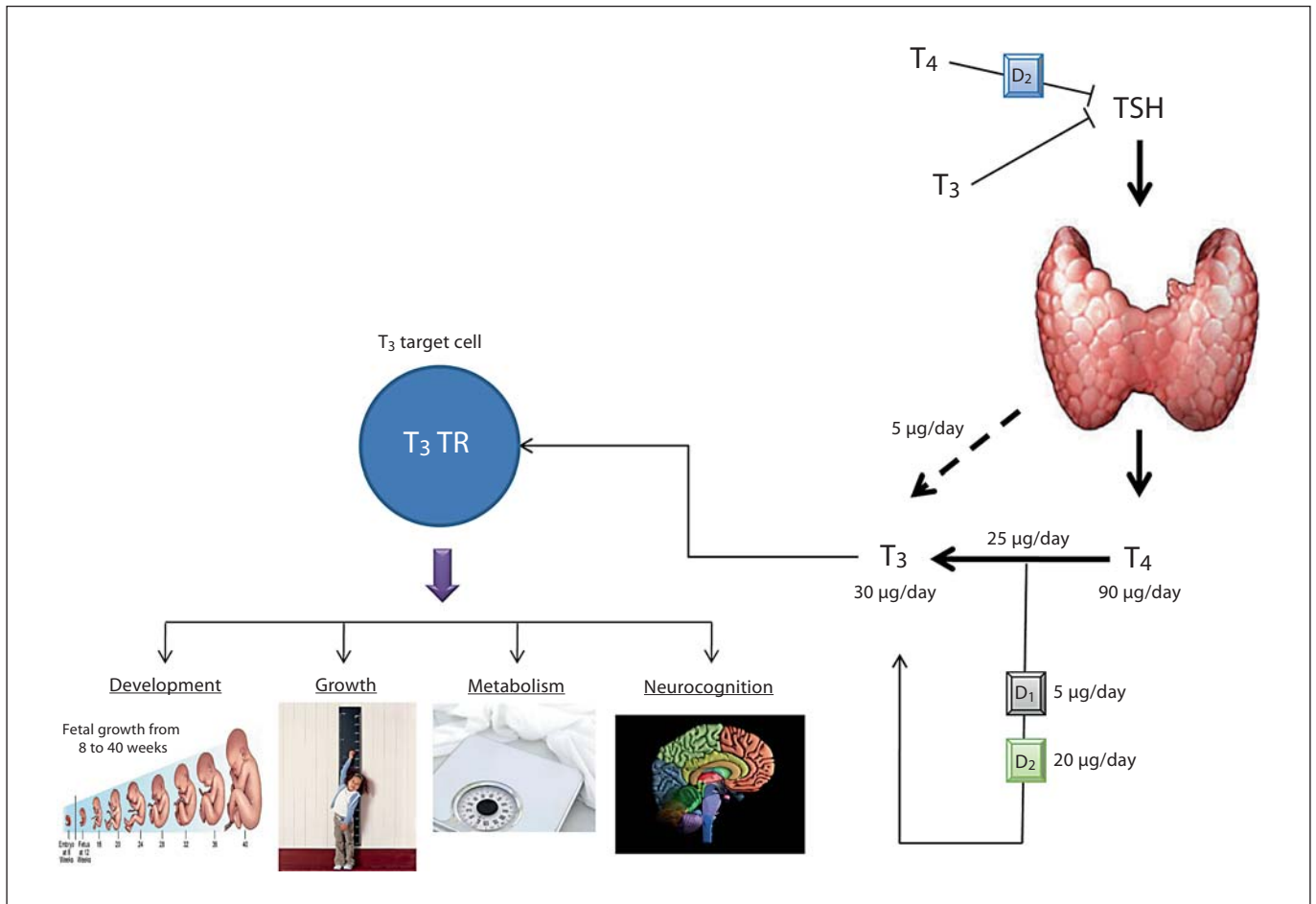

Fig. 1. Major aspects of thyroid hormone economy in healthy human subjects. The human thyroid produces approximately 90 µg of T₄ and 5 µg of T₃ daily; deiodinases (D₁ and D₂) in extrathyroidal tissues are responsible for the production of approximately 25 µg daily. Plasma T₃ enters thyroid hormone target cells and binds

to TRs, changing the expression of T₃-responsive genes. The subsequent changes in specific mRNA levels underlie the biological effects of thyroid hormone in various tissues during development, growth, metabolism and neurocognition.

mal serum T₃ levels, but its brain has only half as much T₃ when compared to a normal mouse [28, 29]. Even the mouse with combined D₁/D₂ inactivation exhibits normal serum T₃, revealing a remarkable ability of the murine thyroid to upregulate T₃ secretion when extrathyroidal T₃ production is abolished [30, 31]. A similar compensatory mechanism is expected to exist in humans, even though the human thyroid contributes much less to the daily T₃ production. Thus, based on the mouse studies, it is very unlikely that patients with a ‘defect’ in the activating deiodinase pathway would be identified by a low serum T₃. Remarkably, each of these animals has a normal serum T₃ concentration and an increased serum T₄ concentration. The elevations in serum T₄ concentration may

result from increased thyroïdal secretion and/or decreased clearance, but in either case it is fascinating that the hypothalamic-pituitary-thyroid axis could be wired such that adjustments in serum T₄ concentrations are made in order to maintain serum T₃ concentrations [32]. Thus, it is tempting to speculate that serum T₃ plays a critical role for some cells/tissues, perhaps the ones that do not exhibit significant deiodinase expression.

Only direct measurements of tissue T₃ can answer the first question. Human tissues have been processed for T₃ content largely in the context of embryonic development or non-thyroidal illnesses [33–35], and not to address the ‘first’ question. Only studies in rats have addressed this point and the answer is a resonant ‘no’, i.e. extrathyroidal

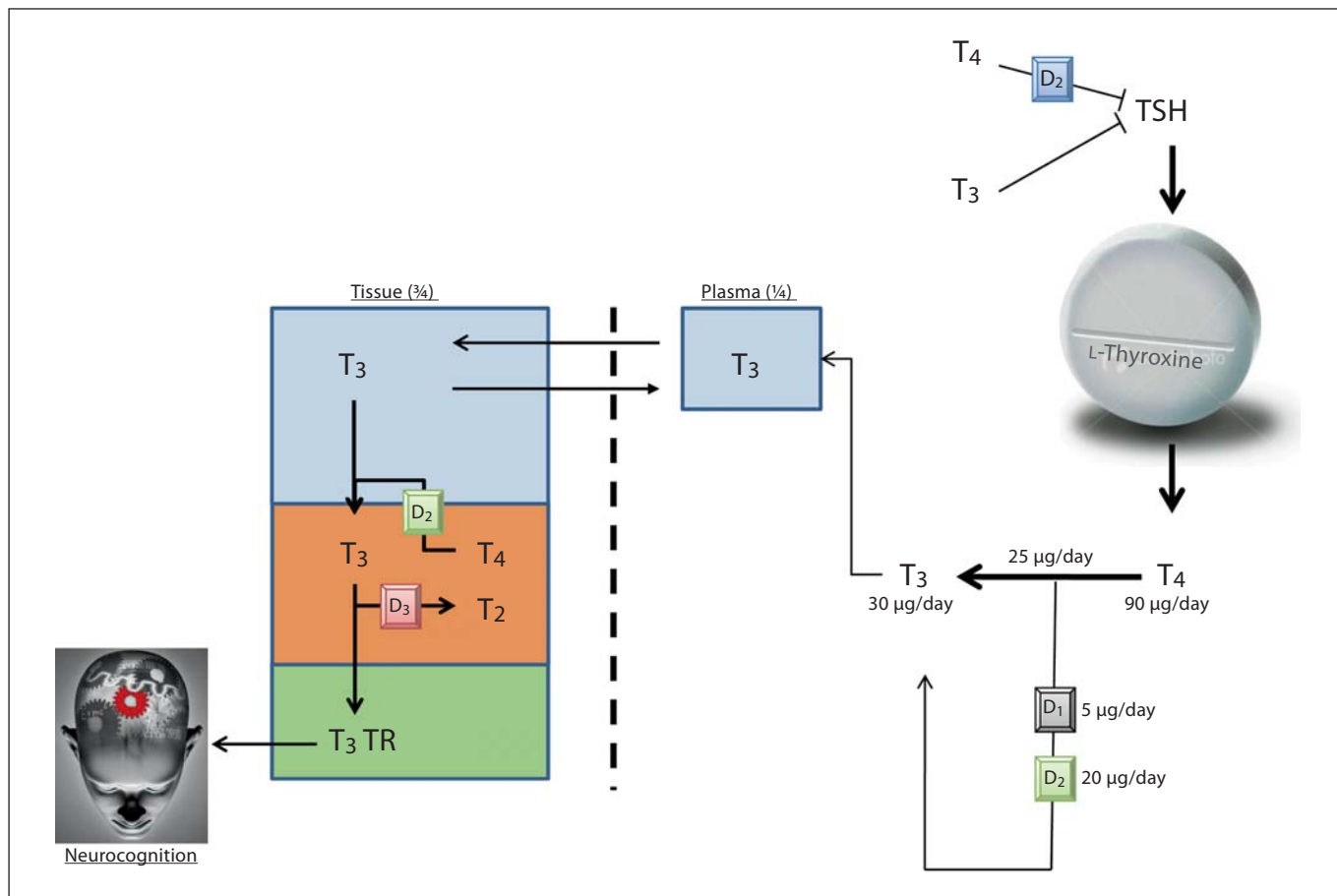

Fig. 2. Serum T₃ does not reflect brain T₃ levels. Three-quarters of the extrathyroidal T₃ are located inside the cells. Despite the existing equilibrium between the plasma and tissue compartments, serum T₃ does not faithfully reflect tissue T₃ levels because

plasma T₃ is not the only source of tissue T₃. In fact, substantial amounts of T₃ are constantly produced and degraded inside specific cells and tissues, e.g. brain, pituitary gland or brown adipose tissue.

metabolism of T₄ does not normalize T₃ content in most tissues [36]. However, prudence should be exercised while extrapolating rodent data to humans given that in rats the thyroidal contribution to T₃ production is much larger than in humans, about 40% [14].

Nonetheless, when thyroidectomized rats were given a range of T₄ doses (0.2–8.0 µg/100 g b.w./day), no single dose of T₄ was able to restore normal serum TSH, T₄ and T₃, as well as T₄ and T₃ in all tissues, or at least to restore T₃ simultaneously in plasma and all tissues, except for the brain [36]. Indeed, central to our discussion is the fact that T₃ content in the cerebral cortex and cerebellum was indeed normalized over a wide range of T₄ doses, even by doses that were not sufficient to normalize serum TSH [36] (fig. 3). Thus, the normal rat brain (and probably the human brain as well) contains a highly efficient D₂-me-

diated mechanism that maintains its T₃ concentration based on circulating T₄. This agrees with the undeniable observation that about 85–90% of all patients with hypothyroidism on levothyroxine therapy alone are clinically and biochemically euthyroid, living normal healthy lives.

The Second Question: Can a Variability/Defect in Thyroid Hormone Metabolism and/or Transport Affect Tissue T₃ and Be Clinically Relevant?

The fascinating aspect of the thyroid hormone transport across cell membranes combined with the deiodinase-mediated control of thyroid hormone action is that thyroid hormone signaling can be customized in a cell- and time-specific fashion, independently of serum T₃ lev-

Fig. 3. T₃ and T₄ levels in the cerebral cortex of hypothyroid rats infused with either T₄ or T₃. Note that in T₄-infused rats, brain T₃ normalizes at doses of T₄ that do not normalize brain T₄ levels. In addition, even at much higher T₄ doses, brain T₃ remains normal despite almost 4-fold higher brain T₄ levels. These observations highlight the critical role played by D₂ and D₃ in brain T₃ homeostasis. Brain T₃ content can also be normalized in T₃-infused rats but only when the doses of infused T₃ are approximately 3-fold higher than the physiological replacement dose of T₃ (about 0.3 μg/100 g b.w.). Modified from Escobar-Morreale et al. [36].

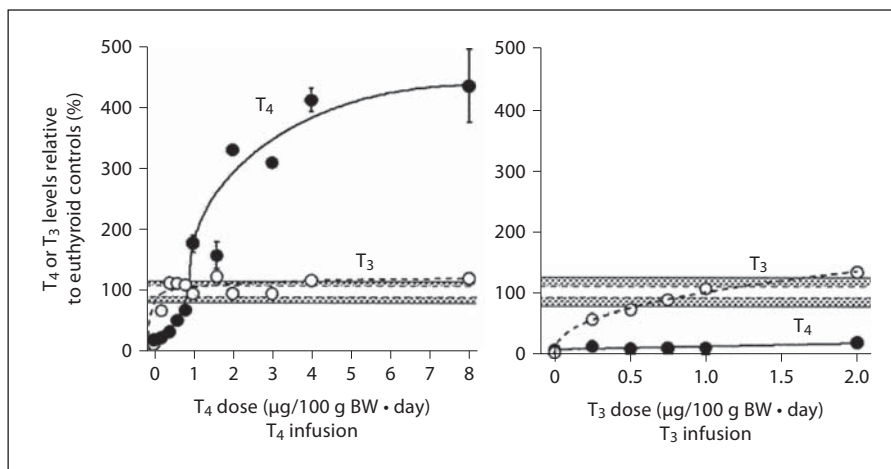

els [8, 11, 16]. In fact, in healthy adult individuals, serum levels of T₄ and T₃ are remarkably constant throughout life [37], unlike the T₃ tissue content that can change rapidly in response to a number of developmental, metabolic and environmental cues [38]. Thus, it is logical to suppose that those patients who still experience neurocognitive impairment despite normalization of serum TSH, T₄ and T₃ concentrations lack sufficient T₃ in discrete brain areas due to a variability/defect in D₂ and/or D₃ pathways or thyroid hormone transport in the brain.

Deiodinase Pathways

Loss-of-function mutations have not been reported in any of the deiodinase genes. However, there is a report of two families in which 3 affected individuals exhibited transient growth retardation as a result of defective deiodinase expression due to a broad deficiency in selenoprotein synthesis [39]. This is an extremely rare syndrome that affects the synthesis of the three deiodinases. No data are available on whether such individuals exhibit alterations in tissue T₃ content. However, because it is so rare, it is unlikely to impact significantly the present discussion.

A D₁-deficient mouse (D₁KO) exhibits elevated serum levels of T₄ and rT₃, whereas serum TSH and T₃ as well as several indices of peripheral thyroid status are unaffected [40, 41]. However, D₁ deficiency results in increased fecal excretion of endogenous iodothyronines suggesting that D₁ may play a major role in limiting the impact of iodine deficiency [41]. At the same time, in humans a single nucleotide polymorphism rs2235544 of DIO1 gene has been identified [42] in association with an increase in free T₃ and a decrease in FT₄ and rT₃ with no effect on serum

TSH levels. Similarly, carriers of the D_{1b}-G/T (rs12095080) allele in elderly individuals had higher serum T₃ and T₃/rT₃ [43]. On the other hand, D_{1a}-C/T (rs11206244) carriers had higher serum FT₄ and rT₃, lower T₃, and lower T₃/rT₃ [43]. Despite biochemical differences in thyroid hormone serum levels, no data are available regarding tissue T₃ levels and, more importantly, no clinical syndrome has been identified in carriers of these polymorphisms.

The D₂KO mouse exhibits a rich phenotype based on alterations of tissue T₃. The BAT [44–46], brain and pituitary gland [31, 47], skeleton [48], skeletal muscle [49, 50] and lungs [51] have all been extensively studied with major phenotypes attributed to deficient local generation of T₃ via the D₂ pathway. This of course opens the door for the existence of individuals with clinical syndromes caused by potential variability/defects in the D₂ pathway. This is particularly true for the brain, where T₃ content is dramatically affected by the D₂ pathway [31, 52]. D₂ is responsible for more than half of the T₃ present in the murine brain [52]. Accordingly, D₂KO animals have half as much brain T₃ content as their wild-type siblings [31], greatly supporting the idea that any interference in the D₂ pathway could affect brain function and/or result in intellectual or cognitive symptoms.

A potentially relevant polymorphism in the DIO2 gene (Thr92AlaD₂) has been described in about 15% of normal individuals [53] (fig. 4a, b). This was originally associated with insulin resistance and increased BMI [53], and subsequently with type 2 diabetes mellitus [54]. A recent case-control study with 1,057 type 2 diabetes patients and 516 non-diabetic subjects indicated that the frequencies of D₂ Ala92Ala homozygosity were 16.4% (n = 173) versus 12.0% (n = 62) in diabetic versus controls,

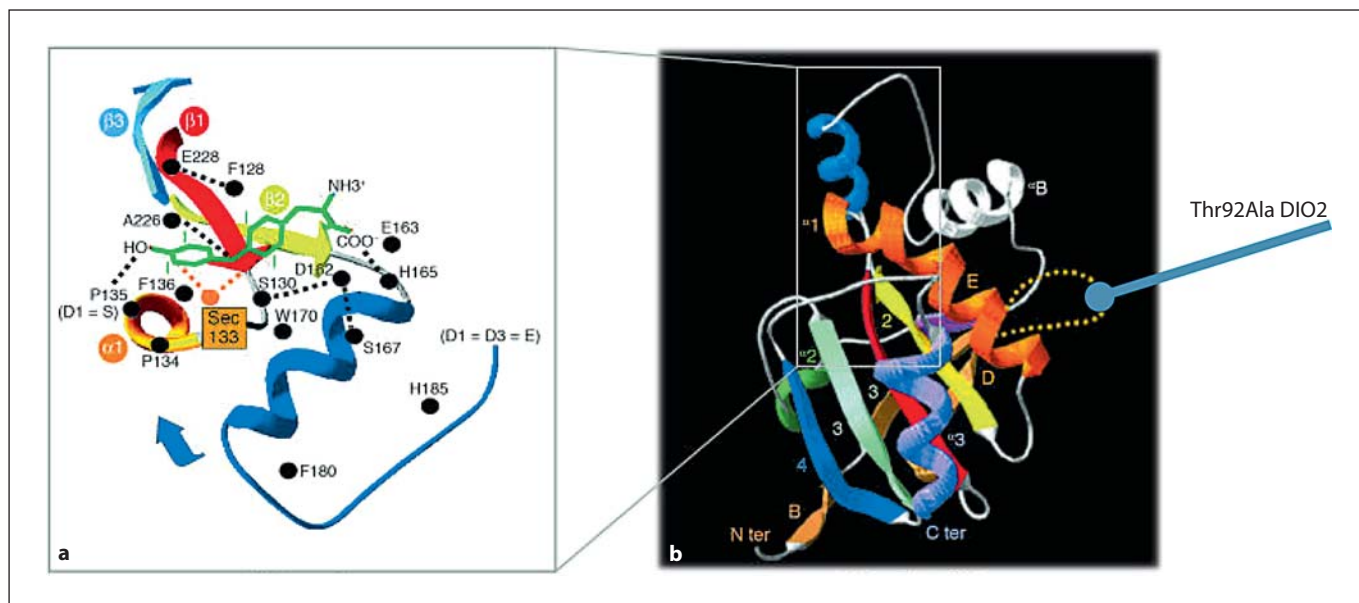

Fig. 4. 3D model of D_2 . **a** 3D model of the enzyme's active center is shown including the critical selenocysteine (Sec) at position 133. **b** Most of the enzyme's structure is shown including the 18-amino-acid loop that controls D_2 half-life [101] and contains the Thr92Ala polymorphism. Modified from Callebaut et al. [102].

Table 1. Clinical features associated with the Thr92Ala D_2 polymorphism

Association	Reference (first author)
Insulin resistance and increased BMI Type 2 diabetes	Mentuccia [53]
	Canani [54]
	Dora [55]
Mental retardation	Guo [56]
Hypertension	Gumieniak [57]
Osteoarthritis	Meulenbelt [58]
Bipolar disorder	He [59]
Clinical manifestations of thyrotoxic cardiomyopathy	Grineva [60]
	Heemstra [61]
Accelerated bone turnover	Barca-Mayo [51]
Response to lung injury	Ma [62]

respectively, resulting in an adjusted odds ratio of 1.41 (CI 95% 1.03–1.94, $p = 0.03$) [55]. These data indicate that the homozygosity for D_2 Thr92Ala polymorphism is associated with increased risk for type 2 diabetes, a conclusion that was supported by a meta-analysis including 11,033 individuals [55]. Today there is a much broader spectrum of diseases and conditions that have been associated with the Thr92Ala D_2 polymorphism, including mental retar-

dation [56], hypertension [57], osteoarthritis [58], bipolar disorder [59], clinical course and myocardial remodeling [60], accelerated bone turnover [61], response to lung injury [51, 62], indicating that indeed this locus (and the Thr92Ala D_2 polymorphism) is clinically relevant (table 1).

Within the context of this discussion, the logical assumption is that the Thr92Ala D_2 polymorphism results in decreased D_2 activity and thus localized tissue T_3 deficiency and hypothyroidism. However, different groups have failed to detect differences in enzyme kinetics ($K_m(T_4)$ and V_{max}) of the Thr92Ala D_2 protein when transiently expressed in cultured cells [54, 63]. A single study in tissue samples of individuals with the Thr92Ala D_2 polymorphism revealed decreased V_{max} in biopsies of skeletal muscle and thyroid gland [54]. However, the data in skeletal muscle have since lost relevance given the subsequent discovery that special technical considerations are needed to correctly assay skeletal muscle D_2 activity [15, 64], which were not considered in the said study [54]. Nevertheless, the reported decrease in thyroidal Thr92Ala D_2 V_{max} remains unchallenged, albeit not yet reproduced by other groups. Two studies in patients indirectly support the view that Thr92Ala D_2 is a catalytically less active enzyme: (i) higher doses of levothyroxine were needed to achieve target TSH levels in 191 thyroid-

ectomized individuals carrying Thr92AlaD₂ polymorphism [65] and (ii) the finding that the Thr92AlaD₂ polymorphism is associated with a delayed T₃ secretion in response to TRH stimulation [66]. Furthermore, all studies agree that patients with the Thr92AlaD₂ polymorphism have no alterations in all other thyroid function tests [63].

At the same time, it is important to highlight that the literature about the Thr92AlaD₂ polymorphism is controversial, with poor reproducibility amongst different studies [67–72]. This suggests that additional unidentified linkage factors such as ethnic background could play a significant role in the physiological and clinical relevance of the Thr92AlaD₂ polymorphism [71, 73]. If future studies by other groups identify and isolate such factors and confirm the observation that Thr92AlaD₂ polymorphism limits D₂'s ability to produce T₃, then 'yes' a variability/defect in the deiodination pathway that controls tissue T₃ could be clinically relevant based on the multiple phenotypes associated with said polymorphism. At the time of this writing, other DIO2 polymorphisms have been reported, but their clinical relevance is even less well established [74].

The D₃KO mouse exhibits the richest phenotype of all deiodinase KO animals, which stems from elevated tissue T₃ during developmental and post-natal life [18, 75–77]. The D₃KO mouse has central hypothyroidism (as a result of enhanced T₃ signaling in the hypothalamus), growth delay and a major central nervous system phenotype including problems with survival and maturation of cone photoreceptors [77] and in cochlear development and auditory function [78], as well as aggressiveness and infertility [75, 76, 79]. However, despite the potential for multiple clinical symptoms in humans, no relevant DIO3 mutations or polymorphisms or mutations have been described in humans that are relevant for the 'second' question.

Thyroid Hormone Transport Pathways

It is clear that localized thyroid hormone deficiency in the brain could result from a variability/defect in thyroid transport across cell membranes as well. In order for T₃ to establish a transcriptional footprint in the brain, both T₃ and T₄ need to move across the blood-brain barrier, in and out of cells. T₄ is taken up by D₂-containing astrocytes and tanycytes and the resulting locally generated T₃ must then exit these D₂-containing cells and enter TR-containing neighboring neurons to finally trigger its transcriptional effects [80, 81]. A variability/defect in any of these steps could affect intracellular T₃ content and lead to localized brain hypothyroidism. This is illustrated

in patients with the Allan-Herndon-Dudley syndrome, carriers of an inactivating mutation in the X-linked MCT8 gene, a member of the MCT family that preferentially transports T₃ across cell membranes and is highly expressed in several organs including the brain. Patients with this syndrome exhibit psychomotor retardation and neurological impairment, indicating brain-specific hypothyroidism during development [82, 83].

Other thyroid hormone transporters have been identified, including the blood-brain barrier-specific anion transporter OATPIC1, mainly expressed in capillaries throughout the brain for which T₄ has a high affinity and specificity [8, 11]. In rats, OATPIC1 mRNA and protein are up- or downregulated depending on the T₄ serum levels, suggesting that this transporter plays a role in preserving physiologic concentrations of T₄ (and thus T₃) in the brain [84]. Interestingly, a clinical analysis of 141 hypothyroid participants of a randomized clinical trial revealed that OATPIC1 polymorphisms are associated with fatigue and depression but were not linked to neurocognitive dysfunction [85].

The Third Question: Can a Deficiency in Brain T₃ Be Restored by Treatment with Combined Levothyroxine and Liothyronine Therapy?

There is circumstantial evidence supporting the paradigm that a variability/defect in thyroid hormone transport and/or metabolism could lead to insufficient T₃ in discrete brain areas of levothyroxine-treated patients explaining their residual neurocognitive impairment despite normalization of serum TSH, T₄ and T₃ concentrations. However, what makes this issue particularly challenging is that such a variability/defect(s) would be silenced by a functional thyroid gland, only to become clinically relevant after the onset of hypothyroidism and treatment with levothyroxine. This could be an indication that the small amounts of T₃ contained in thyroid secretion would be sufficient to compensate for such a variability/defect, making it unlikely that levothyroxine alone would restore brain T₃ in such individuals. In fact, even when the transport/metabolism pathways in the rat brain are fully functional, brain T₃ did not increase (and remained fairly stable) in hypothyroid rats receiving a wide range (20-fold) of T₄ doses [36]. In contrast, brain T₃ increased progressively in hypothyroid rats treated with a much narrower range (8-fold) of T₃ doses [86].

Thus, it is conceivable that administration of liothyronine could restore brain euthyroidism in hypothyroid

individuals that remain clinically symptomatic on levothyroxine therapy. For example, if a variability/loss of function mutation in the D₂ pathway or in one of the thyroid hormone transporter genes is behind the persistent psychological impairment, such patients would benefit clinically from taking liothyronine, bypassing the variability/defect. However, even if successful, such a strategy has the obvious caveat that not only the brain but all tissues would be exposed to the additional T₃, thus essentially creating a state of systemic thyrotoxicosis for life [87].

A series of clinical trials indicate that a relative elevation in serum T₃ can be achieved by switching patients from monotherapy with levothyroxine to a combined therapy with levothyroxine and liothyronine [87–91]. The elevation in serum T₃ is variable, depending on the dose of liothyronine used. Multiple combination regimens exist, with levothyroxine:liothyronine ratios being applied at 10:1 to 5:1 [87]. A recent meta-analysis of ten such randomized controlled studies confirmed that serum TSH did not vary significantly between the monotherapy and combined therapy groups, but serum FT₄ levels decreased and total serum T₃ increased significantly in the patients switching to combined therapy [92]. In other regimens, relatively less T₃ is used and the switch to combined therapy does not elevate serum T₃ levels [93]. However, given the relatively short T₃ half-life of about 12 h in humans, a normal serum T₃ in the morning actually indicates that during the preceding 24 h the integrated serum T₃ fluctuated at higher levels in the patients receiving combined therapy. In fact, the 24-hour profile of individuals placed on such mild combined therapies indicates that serum free T₃ levels increased significantly, by about 40%, within the first 4-hour post-dose, with an integrated area under the curve for serum free T₃ significantly higher by about 10% [94]. In contrast, there is only a modest 16% rise in serum FT₄ with no change in serum free T₃ in the first 4-hour post-levothyroxine dose [94].

Despite the logic of this rationale, most randomized clinical trials (with three exceptions [88, 89, 95]) comparing monotherapy versus combined therapy failed to reveal a statistically significant difference in clinical outcomes [96]. The meta-analysis of eleven studies, in which 1,216 patients were randomized, found no difference in the effectiveness of monotherapy versus combined therapy symptoms such as bodily pain, depression, anxiety, fatigue, quality of life, body weight, total serum cholesterol, triglyceride levels, low-density lipoprotein, and high-density lipoprotein [96]. Yet, even when the objective methods used to assess the well-being of the patients

did not uncover a meaningful change, patients did seem to prefer combined therapy [97].

The discovery of polymorphisms in the genes of the deiodinases and thyroid hormone transporters led to the obvious hypothesis that subgroups of hypothyroid patients respond differently to monotherapy versus combined therapy depending on their genetic makeup. This hypothesis was tested and the results seem encouraging, particularly in the light of a relatively large analysis of 552 individuals in the WATTS study, suggesting that the combined therapy is associated with a favorable clinical outcome in patients exhibiting the Thr92AlaD₂ polymorphism [98]. In the WATTS study, the thyroid hormone formulation used included the simultaneous reduction in the dose of levothyroxine by 50 µg/day and the introduction of 10 µg/day of liothyronine [98].

Notably, not all studies involving the Thr92AlaD₂ polymorphism resulted in such clear-cut results [97]. However, given that this D₂ polymorphism is present in a relatively small proportion of the population on levothyroxine, previous studies are likely to have been underpowered to see this effect [97]. Likewise, no differences in appreciation for the combined therapy were observed in a relatively small sample of patients carrying OATP1C1 polymorphisms [85].

Conclusions

The vast majority of the hypothyroid patients achieve biochemical and clinical euthyroidism on thyroid hormone replacement therapy with levothyroxine alone. A small group of hypothyroid patients on monotherapy with levothyroxine remain clinically symptomatic with impaired neurocognitive functions despite normalization of serum TSH, T₄ and T₃ levels. This could be attributed to localized brain hypothyroidism due to a variability/defect in thyroid hormone transport and/or metabolism. Addition of liothyronine to the treatment regimen could theoretically restore brain euthyroidism and, in fact, depending on the dose of liothyronine used, patients who switched from monotherapy to combined therapy exhibited elevation in serum T₃. However, a large number of clinical trials did not find improved outcomes with combined therapy. Only recently a polymorphism in the DIO2 gene, which could result in decreased D₂ activity, was taken into consideration. In the WATTS trial, the largest so far, only hypothyroid patients carrying the Thr92AlaD₂ polymorphism exhibited favorable outcomes on combined therapy, indicat-

ing that personalized medicine is catching up with thyroid disease. More studies are needed to further evaluate this question, but in the meantime the report of a slow-release liothyronine preparation seems to offer a more stable T₃ level over time [99, 100], opening the doors to an appealing new approach to mildly and steadily elevate serum T₃ in some hypothyroid patients to offset variability/defects in thyroid hormone signaling in the brain.

References

- Aoki Y, et al: Serum TSH and total T₄ in the United States population and their association with participant characteristics: National Health and Nutrition Examination Survey (NHANES 1999–2002). *Thyroid* 2007;17:1211–1223.
- Madhukar Aryal, et al: A prevalence of thyroid dysfunction in Kathmandu University Hospital, Nepal. *Biomed Res* 2010;21:4.
- Singer PA, et al: Treatment guidelines for patients with hyperthyroidism and hypothyroidism. *JAMA* 1995;273:808–812.
- Larsen PR, Silva JE, Kaplan MM: Relationships between circulating and intracellular thyroid hormones: physiological and clinical implications. *Endocr Rev* 1981;2:87–102.
- Murray GR: The life-history of the first case of myxoedema treated by thyroid extract. *Br Med J* 1920;i:359–360.
- Braverman LE, Ingbar SH, Sterling K: Conversion of thyroxine (T₄) to triiodothyronine (T₃) in athyreotic subjects. *J Clin Invest* 1970;49:855–864.
- Saravanan P, et al: Psychological well-being in patients on 'adequate' doses of L-thyroxine: results of a large, controlled community-based questionnaire study. *Clin Endocrinol (Oxf)* 2002;57:577–585.
- Visser WE, Friesema EC, Visser TJ: Thyroid hormone transporters: the knowns and the unknowns. *Mol Endocrinol* 2011;25:1–14.
- Wu Y, Koenig RJ: Gene regulation by thyroid hormone. *Trends Endocrinol Metab* 2000;11:207–211.
- Zhang J, Lazar MA: The mechanism of action of thyroid hormones. *Annu Rev Physiol* 2000;62:439–466.
- Jansen J, et al: Thyroid hormone transporters in health and disease. *Thyroid* 2005;15:757–768.
- Saberi M, Sterling FH, Utiger RD: Reduction in extrathyroidal triiodothyronine production by propylthiouracil in man. *J Clin Invest* 1975;55:218–223.
- Geffner DL, Azukizawa M, Hershman JM: Propylthiouracil blocks extrathyroidal conversion of thyroxine to triiodothyronine and augments thyrotropin secretion in man. *J Clin Invest* 1975;55:224–229.
- Bianco AC, et al: Biochemistry, cellular and molecular biology and physiological roles of the iodothyronine selenodeiodinases. *Endocr Rev* 2002;23:38–89.
- Ramadan W, et al: Type-2 iodothyronine 5'-deiodinase in skeletal muscle of C57BL/6 mice. I. Identity, subcellular localization, and characterization. *Endocrinology* 2011;152:3082–3092.
- Gereben B, et al: Cellular and molecular basis of deiodinase-regulated thyroid hormone signaling. *Endocr Rev* 2008;29:898–938.
- Galton VA: The roles of the iodothyronine deiodinases in mammalian development. *Thyroid* 2005;15:823–834.
- Medina MC, et al: The thyroid hormone-inactivating type III deiodinase is expressed in mouse and human β -cells and its targeted inactivation impairs insulin secretion. *Endocrinology* 2011;152:3717–3727.
- Peeters RP, et al: Reduced activation and increased inactivation of thyroid hormone in tissues of critically ill patients. *J Clin Endocrinol Metab* 2003;88:3202–3211.
- Huang SA, Bianco AC: Reawakened interest in type III iodothyronine deiodinase in critical illness and injury. *Nat Clin Pract Endocrinol Metab* 2008;4:148–155.
- Braverman LE, et al: Effects of replacement doses of sodium L-thyroxine on the peripheral metabolism of thyroxine and triiodothyronine in man. *J Clin Invest* 1973;52:1010–1017.
- Stock JM, Surks MI, Oppenheimer JH: Replacement dosage of L-thyroxine in hypothyroidism. A re-evaluation. *N Engl J Med* 1974;290:529–533.
- Jonklaas J, et al: Triiodothyronine levels in athyreotic individuals during levothyroxine therapy. *JAMA* 2008;299:769–777.
- Gullo D, et al: Levothyroxine monotherapy cannot guarantee euthyroidism in all athyreotic patients. *PLoS One* 2011;6:e22552.
- Oppenheimer JH, Schwartz HL, Surks MI: Determination of common parameters of iodothyronine metabolism and distribution in man by noncompartmental analysis. *J Clin Endocrinol Metab* 1975;41:319–324.
- Baqui MM, et al: Distinct subcellular localization of transiently expressed types 1 and 2 iodothyronine deiodinases as determined by immunofluorescence confocal microscopy. *Endocrinology* 2000;141:4309–4312.
- Friesema EC, et al: Thyroid hormone transport by the human monocarboxylate transporter 8 and its rate-limiting role in intracellular metabolism. *Mol Endocrinol* 2006;20:2761–2772.
- Schneider MJ, et al: Targeted disruption of the type 2 selenodeiodinase gene (DIO2) results in a phenotype of pituitary resistance to T₄. *Mol Endocrinol* 2001;15:2137–2148.
- Hall JA, Bianco AC: Triumphs of the thyroid despite lesser conversion. *Endocrinology* 2009;150:2502–2504.
- Christoffolete MA, et al: Mice with impaired extrathyroidal thyroxine to 3,5,3'-triiodothyronine conversion maintain normal serum 3,5,3'-triiodothyronine concentrations. *Endocrinology* 2007;148:954–960.
- Galton VA, et al: Life without T₄ to T₃ conversion: studies in mice devoid of the 5'-deiodinases. *Endocrinology* 2009;150:2957–2963.
- Bianco AC, Kim BW: Deiodinases: implications of the local control of thyroid hormone action. *J Clin Investigation* 2006;116:2571–2579.
- Campos-Barros A, et al: Phenolic and tyrosyl ring iodothyronine deiodination and thyroid hormone concentrations in the human central nervous system. *J Clin Endocrinol Metab* 1996;81:2179–2185.
- Peeters RP, et al: Tissue thyroid hormone levels in critical illness. *J Clin Endocrinol Metab* 2005;90:6498–6507.
- Kester MH, et al: Iodothyronine levels in the human developing brain: major regulatory roles of iodothyronine deiodinases in different areas. *J Clin Endocrinol Metab* 2004;89:3117–3128.
- Escobar-Morreale HF, et al: Replacement therapy for hypothyroidism with thyroxine alone does not ensure euthyroidism in all tissues, as studied in thyroidectomized rats. *J Clin Invest* 1995;96:2828–2838.

Acknowledgement

The authors are grateful to Dr. Brian Kim for critically reading the manuscript and to the NIH support, DK58538, DK65055, DK77148.

Disclosure Statement

The authors have no conflicts of interest to disclose.

- 37 Andersen S, et al: Biologic variation is important for interpretation of thyroid function tests. *Thyroid* 2003;13:1069–1078.
- 38 Bianco AC, Silva JE: Cold exposure rapidly induces virtual saturation of brown adipose tissue nuclear T₃ receptors. *Am J Physiol* 1988;255:E496–E503.
- 39 Dumitrescu AM, et al: Mutations in SECISBP2 result in abnormal thyroid hormone metabolism. *Nat Gen* 2005;37:1247–1252.
- 40 Berry MJ, et al: Physiological and genetic analyses of inbred mouse strains with a type I iodothyronine 5'-deiodinase deficiency. *J Clin Invest* 1993;92:1517–1528.
- 41 Schneider MJ, et al: Targeted disruption of the type 1 selenodeiodinase gene (*Dio1*) results in marked changes in thyroid hormone economy in mice. *Endocrinology* 2006;147:580–589.
- 42 Dayan CM, Panicker V: Novel insights into thyroid hormones from the study of common genetic variation. *Nat Rev Endocrinol* 2009;5:211–218.
- 43 De Jong FJ, et al: The association of polymorphisms in the type 1 and 2 deiodinase genes with circulating thyroid hormone parameters and atrophy of the medial temporal lobe. *J Clin Endocrinol Metab* 2007;92:636–640.
- 44 De Jesus LA, et al: The type 2 iodothyronine deiodinase is essential for adaptive thermogenesis in brown adipose tissue. *J Clin Invest* 2001;108:1379–1385.
- 45 Christoffolete MA, et al: Mice with targeted disruption of the *DIO2* gene have cold-induced overexpression of the uncoupling protein 1 gene but fail to increase brown adipose tissue lipogenesis and adaptive thermogenesis. *Diabetes* 2004;53:577–584.
- 46 Hall JA, et al: Absence of thyroid hormone activation during development underlies a permanent defect in adaptive thermogenesis. *Endocrinology* 2010;151:4573–4582.
- 47 Ng L, et al: Hearing loss and retarded cochlear development in mice lacking type 2 iodothyronine deiodinase. *Proc Natl Acad Sci USA* 2004;101:3474–3479.
- 48 Bassett JH, et al: Optimal bone strength and mineralization requires the type 2 iodothyronine deiodinase in osteoblasts. *Proc Natl Acad Sci USA* 2010;107:7604–7609.
- 49 Marsili A, et al: Type II iodothyronine deiodinase provides intracellular 3,5,3'-triiodothyronine to normal and regenerating mouse skeletal muscle. *Am J Physiol Endocrinol Metab* 2011;301:E818–E824.
- 50 Dentice M, et al: The *FoxO3*/type 2 deiodinase pathway is required for normal mouse myogenesis and muscle regeneration. *J Clin Invest* 2011;120:4021–4030.
- 51 Barca-Mayo O, et al: Role of type 2 deiodinase in response to acute lung injury in mice. *Proc Natl Acad Sci USA* 2011;108:E1321–E1329.
- 52 Crantz FR, Silva JE, Larsen PR: Analysis of the sources and quantity of 3,5,3'-triiodothyronine specifically bound to nuclear receptors in rat cerebral cortex and cerebellum. *Endocrinology* 1982;110:367–375.
- 53 Mentuccia D, et al: Association between a novel variant of the human type 2 deiodinase gene *Thr92Ala* and insulin resistance: evidence of interaction with the *Trp64Arg* variant of the β_3 -adrenergic receptor. *Diabetes* 2002;51:880–883.
- 54 Canani LH, et al: The type 2 deiodinase A/G (*Thr92Ala*) polymorphism is associated with decreased enzyme velocity and increased insulin resistance in patients with type 2 diabetes mellitus. *J Clin Endocrinol Metab* 2005;90:3472–3478.
- 55 Dora JM, et al: Association of the type 2 deiodinase *Thr92Ala* polymorphism with type 2 diabetes: case-control study and meta-analysis. *Eur J Endocrinol* 2010;163:427–434.
- 56 Guo TW, et al: Positive association of the *DIO2* (deiodinase type 2) gene with mental retardation in the iodine-deficient areas of China. *J Med Genet* 2004;41:585–590.
- 57 Gumieniak O, et al: *Ala92* type 2 deiodinase allele increases risk for the development of hypertension. *Hypertension* 2007;49:461–466.
- 58 Meulenbelt I, et al: Identification of *DIO2* as new susceptibility locus for symptomatic osteoarthritis. *Hum Mol Genet* 2008;17:1867–1875.
- 59 He B, et al: Association of genetic polymorphisms in the type II deiodinase gene with bipolar disorder in a subset of Chinese population. *Prog Neuropsychopharmacol Biol Psychiatry* 2009;33:986–990.
- 60 Grineva E, et al: Type 2 deiodinase *Thr92Ala* polymorphism impact on clinical course and myocardial remodeling in patients with Graves' disease. *Cell Cycle* 2009;8:2565–2569.
- 61 Heemstra KA, et al: The type 2 deiodinase *Thr92Ala* polymorphism is associated with increased bone turnover and decreased femoral neck bone mineral density. *J Bone Miner Res* 2010;25:1385–1391.
- 62 Ma SF, et al: Type 2 deiodinase and host responses of sepsis and acute lung injury. *Am J Respir Cell Mol Biol* 2011;45:1203–1211.
- 63 Peeters RP, et al: Polymorphisms in thyroid hormone pathway genes are associated with plasma TSH and iodothyronine levels in healthy subjects. *J Clin Endocrinol Metab* 2003;88:2880–2888.
- 64 Larsen PR: Type 2 iodothyronine deiodinase in human skeletal muscle: new insights into its physiological role and regulation. *J Clin Endocrinol Metab* 2009;94:1893–1895.
- 65 Torlontano M, et al: Type 2 deiodinase polymorphism (*Thr92Ala*) predicts L-thyroxine dose to achieve target TSH levels in thyroidectomized patients. *J Clin Endocrinol Metab* 2008;93:910–913.
- 66 Butler PW, et al: The *Thr92Ala* 5'-type 2 deiodinase gene polymorphism is associated with a delayed triiodothyronine secretion in response to the thyrotropin-releasing hormone-stimulation test: a pharmacogenomic study. *Thyroid* 2011;20:1407–1412.
- 67 Canani LH, et al: Type 2 deiodinase *Thr92Ala* polymorphism is not associated with arterial hypertension in type 2 diabetes mellitus patients. *Hypertension* 2007;49:e47–e48.
- 68 Grarup N, et al: Studies of the common *DIO2* *Thr92Ala* polymorphism and metabolic phenotypes in 7342 Danish white subjects. *J Clin Endocrinol Metab* 2007;92:363–366.
- 69 Gumieniak O, Williams GH: Response to type 2 deiodinase *Thr92Ala* polymorphism is not associated with arterial hypertension in type 2 diabetes mellitus patients. *Hypertension* 2007;49:e47–e48.
- 70 Heemstra KA, et al: *Thr92Ala* polymorphism in the type 2 deiodinase is not associated with T₄ dose in athyroid patients or patients with Hashimoto thyroiditis. *Clin Endocrinol (Oxf)* 2009;71:279–283.
- 71 Nair S, et al: Association analyses of variants in the *DIO2* gene with early-onset type 2 diabetes mellitus in Pima Indians. *Thyroid* 2012;22:80–87.
- 72 Van der Deure WM, et al: Impact of thyroid function and polymorphisms in the type 2 deiodinase on blood pressure: the Rotterdam Study and the Rotterdam Scan Study. *Clin Endocrinol (Oxf)* 2009;71:137–144.
- 73 Mentuccia D, et al: The *Thr92Ala* deiodinase type 2 (*DIO2*) variant is not associated with type 2 diabetes or indices of insulin resistance in the old order of Amish. *Thyroid* 2005;15:1223–1227.
- 74 Peeters RP, van der Deure WM, Visser TJ: Genetic variation in thyroid hormone pathway genes; polymorphisms in the TSH receptor and the iodothyronine deiodinases. *Eur J Endocrinol* 2006;155:655–662.
- 75 Hernandez A, et al: Type 3 deiodinase is critical for the maturation and function of the thyroid axis. *J Clin Invest* 2006;116:476–484.
- 76 Hernandez A, et al: Type 3 deiodinase deficiency results in functional abnormalities at multiple levels of the thyroid axis. *Endocrinology* 2007;148:5680–5687.
- 77 Ng L, et al: Type 3 deiodinase, a thyroid-hormone-inactivating enzyme, controls survival and maturation of cone photoreceptors. *J Neurosci* 2010;30:3347–3357.
- 78 Ng L, et al: A protective role for type 3 deiodinase, a thyroid hormone-inactivating enzyme, in cochlear development and auditory function. *Endocrinology* 2009;150:1952–1960.
- 79 Hernandez A, et al: Type 3 deiodinase deficiency causes spatial and temporal alterations in brain T₃ signaling that are dissociated from serum thyroid hormone levels. *Endocrinology* 2010;151:5550–5558.

- 80 Freitas BC, et al: Paracrine signaling by glial cell-derived triiodothyronine activates neuronal gene expression in the rodent brain and human cells. *J Clin Invest* 2010;120:2206–2217.
- 81 Mohacsik P, et al: Thyroid hormone and the neuroglia: both source and target. *J Thyroid Res* 2011;2011:215718.
- 82 Dumitrescu AM, et al: A novel syndrome combining thyroid and neurological abnormalities is associated with mutations in a monocarboxylate transporter gene. *Am J Hum Genet* 2004;74:168–175.
- 83 Friesema EC, et al: Association between mutations in a thyroid hormone transporter and severe X-linked psychomotor retardation. *Lancet* 2004;364:1435–1437.
- 84 Sugiyama D, et al: Functional characterization of rat brain-specific organic anion transporter (Oatp14) at the blood-brain barrier: high affinity transporter for thyroxine. *J Biol Chem* 2003;278:43489–43495.
- 85 Van der Deure W, Appelhof BC, Peeters RP, Wiersinga WM, Wekkig EM, Huyser J, Schene AH, Tijssen JGP, Hoogendijk WJG, Visser TJ, Fliers E: Polymorphism in the brain-specific thyroid hormone transporter OATP-C1 are associated with fatigue and depression in hypothyroid patients. *Clin Endocrinol* 2008;69:8.
- 86 Escobar-Morreale HF, et al: Regulation of iodothyronine deiodinase activity as studied in thyroidectomized rats infused with thyroxine or triiodothyronine. *Endocrinology* 1997;138:2559–2568.
- 87 Appelhof BC, et al: Combined therapy with levothyroxine and liothyronine in two ratios, compared with levothyroxine monotherapy in primary hypothyroidism: a double-blind, randomized, controlled clinical trial. *J Clin Endocrinol Metab* 2005;90:2666–2674.
- 88 Bunevicius R, et al: Thyroxine vs. thyroxine plus triiodothyronine in treatment of hypothyroidism after thyroidectomy for Graves' disease. *Endocrine* 2002;18:129–133.
- 89 Bunevicius R, et al: Effects of thyroxine as compared with thyroxine plus triiodothyronine in patients with hypothyroidism. *N Engl J Med* 1999;340:424–429.
- 90 Valizadeh M, et al: Efficacy of combined levothyroxine and liothyronine as compared with levothyroxine monotherapy in primary hypothyroidism: a randomized controlled trial. *Endocr Res* 2009;34:80–89.
- 91 Rodriguez T, et al: Substitution of liothyronine at a 1:5 ratio for a portion of levothyroxine: effect on fatigue, symptoms of depression, and working memory versus treatment with levothyroxine alone. *Endocr Pract* 2005;11:223–233.
- 92 Ma C, et al: Thyroxine alone or thyroxine plus triiodothyronine replacement therapy for hypothyroidism. *Nucl Med Commun* 2009;30:586–593.
- 93 Saravanan P, et al: Partial substitution of thyroxine (T₄) with tri-iodothyronine in patients on T₄ replacement therapy: results of a large community-based randomized controlled trial. *J Clin Endocrinol Metab* 2005;90:805–812.
- 94 Saravanan P, et al: Twenty-four hour hormone profiles of TSH, free T₃ and free T₄ in hypothyroid patients on combined T₃/T₄ therapy. *Exp Clin Endocrinol Diabetes* 2007;115:261–267.
- 95 Nygaard B, et al: Effect of combination therapy with thyroxine (T₄) and 3,5,3'-triiodothyronine versus T₄ monotherapy in patients with hypothyroidism, a double-blind, randomised cross-over study. *Eur J Endocrinol* 2009;161:895–902.
- 96 Grozinsky-Glasberg S, et al: Thyroxine-triiodothyronine combination therapy versus thyroxine monotherapy for clinical hypothyroidism: meta-analysis of randomized controlled trials. *J Clin Endocrinol Metab* 2006;91:2592–2599.
- 97 Appelhof BC, et al: Polymorphisms in type 2 deiodinase are not associated with well-being, neurocognitive functioning, and preference for combined thyroxine/3,5,3'-triiodothyronine therapy. *J Clin Endocrinol Metab* 2005;90:6296–6299.
- 98 Panicker V, et al: Common variation in the DIO2 gene predicts baseline psychological well-being and response to combination thyroxine plus triiodothyronine therapy in hypothyroid patients. *J Clin Endocrinol Metab* 2009;94:1623–1629.
- 99 Hennemann G, et al: Thyroxine plus low-dose, slow-release triiodothyronine replacement in hypothyroidism: proof of principle. *Thyroid* 2004;14:271–275.
- 100 Frumess RD, Larsen PR: Correlation of serum triiodothyronine (T₃) and thyroxine (T₄) with biologic effects of thyroid hormone replacement in propylthiouracil-treated rats. *Metabolism* 1975;24:547–554.
- 101 Dentice M, et al: The Hedgehog-inducible ubiquitin ligase subunit WSB-1 modulates thyroid hormone activation and PTHrP secretion in the developing growth plate. *Nat Cell Biol* 2005;7:698–705.
- 102 Callebaut I, et al: The iodothyronine selenodeiodinases are thioredoxin-fold family proteins containing a glycoside hydrolase clan GH-A-like structure. *J Biol Chem* 2003;278:36887–36896.