

Time and Frequency Transfer in Optical Fibers

Per Olof Hedekvist and Sven-Christian Ebenhag
*SP Technical Research Institute of Sweden,
Sweden*

1. Introduction

The development towards more services in the digital domain, based on computers and server logs at different locations and in different networks, increases the need for high precision time indication. Even though GPS can support this with sufficient precision, many users do not have access to outdoor antennas. Furthermore, there is vulnerability in the weak radio-transmission from the satellites (NSTAC) as well as the dependence on the continuous replacement of old and outdated satellites (Chaplain). Therefore, alternative systems to support precise time are needed. Standardization of time transfer of a master clock is done for example in the IRIG system, but this one-way time transfer system do not take variations in transfer time into account, mainly because it is supposed to work on short distances (IRIG). In additional efforts to meet this request, several time and frequency transfer methods using optical fibers have been developed or are under development, using dedicated fibers (Kihara; Jefferts; Ebenhag2008; Kéfélian), dedicated capacity in existing fiber networks (Calhoun) or already existing synchronization in active fiber networks (Emardson, Ebenhag2010a). A similarity of all these techniques is the need for two-way communication to compensate for the inevitable variations of propagation time, such as variation of temperature and mechanical stress along the transmission path. A two-way connection may however be undesirable when many users are connected in one network, or when user privacy is requested. As an alternative, a one-way transmission over fiber optic wavelength division multiplexing network with detection of variation in propagation time has been presented (Ebenhag2010b, Hanssen).

The general conception of fiber optic communication is the transmission of digital data from one user to another, and through recovery of the phase variation of the bit-slots after reception, the exact time it has taken to transfer the data is of low importance. The individual packets of the data may even follow different paths with different propagation time, and still be interpreted correctly at the user end. Physical effects such as noise, dispersion and polarization dependence are important, but as long as each bit can be detected correctly, slow variations in propagation time do not affect the communication. When the fiber is used to transmit time or frequency however, the physical properties of the transmission link become very important. Even though time and frequency may appear as two faces of the same parameter, there are differences in the requirement of a transmission link. For time transfer, any variations in the delay through the link must be compensated for, either in a real time compensator or through post processing. For frequency transfer, the frequency shift caused by the rapidity of a change in the fiber delay must be handled.

During the last years of the 20th century, the development and installation of optical fiber communication systems increased rapidly, and after a few slow years, the deployment has gained new speed. All continents are connected with submarine fiber networks, and all major cities have installed fibers at least for their long distance communication. In regular optical communication however, the propagation time through the fiber is of no major concern. Slow variations are handled through clock recovery at the receiver end. Therefore, little or no efforts have been made to develop transmission links with stable net transmission time. The development of synchronous networks, e.g. following the first version of Synchronous Digital Hierarchy (SDH), was left as soon as the control system could handle asynchronous routing between different links. With the increase of the need for precise time and frequency transfer over optical fibers, the time and time variations is however of outmost importance. This chapter will be a review of the published work, covering both the transfer of low frequency and time, and the necessary techniques for accurate optical frequency transmission. Even though the similarities are apparent, the transmission of frequency and the transmission of time require completely different properties.

1.1 Definition of time

When the definition of time was changed in 1972 from Greenwich Mean Time (GMT) to Universal Coordinated Time (UTC) (OICM), the need to compare clocks became more imminent. While GMT is determined from observations of the sun, UTC is the addition of seconds from Cesium oscillators around the world. These devices are to be compared constantly, and since there are more than 300 oscillators on almost 60 different locations around the world (BIPM), the preferred technique has been over radio transmission, and presently utilizing satellites. As the society moves into an ever increasing request for connectivity, with the subsequent needs for verification, identification, encryption etc. many systems rely on the time signal given. To ensure the quality of time information, and to make it robust towards radio based disturbances, there have been several suggestions on how to communicate between the participating clock laboratories using alternative techniques, and with the long distances at hand, the choice of optical fibers is obvious.

One second is presently defined as the duration of 9 192 631 770 periods of the radiation corresponding to the transition between the two hyperfine levels of the ground state of the Cesium 133 atom (OICM). This definition has been official since 1967, and it does also correspond to the realization of a second. To increase the accuracy further, is there ongoing research on optical clocks. Optical clocks are defined by the output of an optical frequency standard and can offer an extremely high frequency precision and stability, exceeding the performance of the best Cesium atomic clocks. A challenge in the early years of optical clocks was to relate the stable optical frequency to a microwave frequency standard such as a Cesium atomic clock. This was solved with the realization of frequency combs from femtosecond mode-locked lasers (Paschotta). Optical clocks compared to microwave standards such as Cesium atomic clocks have some key advantages:

- There are certain atoms and ions with extremely well-defined clock transitions that promise higher accuracy and stability than the best microwave atomic clocks. The anticipated (but not yet demonstrated) relative frequency uncertainty of atomic optical clocks for long enough averaging times (possibly a few days) is of the order of 10^{-18} (Paschotta).

- The high optical frequencies themselves are of high importance because these allow precise clock comparisons within much shorter times. For example, a 10^{-15} precision can be achieved in a few seconds if the compared frequencies are in the optical range, whereas a full day would be required for microwave clocks.
- Optical signals can easily be transported over long distances using fibers whereas microwave cables are more expensive and have much higher losses.

Therefore, it is to be expected that in the near future the Cesium clock as the fundamental timing reference will be replaced with an optical clock, although it is at the moment not clear which type of optical clock would be used as such a standard. The definition of the second will then be changed to refer to an optical frequency rather than to a microwave frequency. However, even after that profound change, Cesium clocks (and other non-optical atomic clocks, such as Rubidium clocks) will continue to play an important role in technological applications as they can be simpler and more compact than optical clocks (Paschotta). In the purpose to be able to compare two optical clocks, the optical wave must be compared. To manage this, the optical link must be stable when it comes to frequency.

1.2 Temperature of trunk fiber

In all utilization of optical fiber, the influence of the environment must be handled, even though the solutions depend on the application, knowledge about which properties to take into account, and their magnitudes, is of equal importance. In time and frequency transfer, the surrounding temperature is the main source for variations and to estimate the size, some data is analyzed.

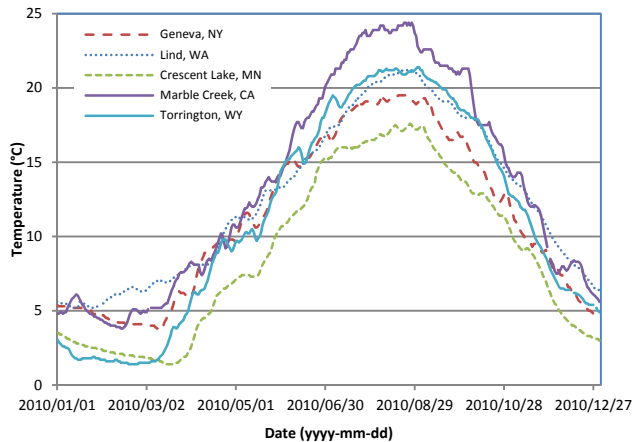

Fig. 1. Soil temperature at 40" depth, at five US locations.

Most fiber in the terrestrial networks is buried in the ground, at a depth of about 1 - 2m. A common misconception is that this would be a stable environment with respect to temperature. Figure 1 shows the measured soil temperature at 40" depth (approx. 1 m) at five different US locations, measured daily during 2010 (NRCS). The locations are all in the northern part of the country, with warm summers and cold winters, and represents examples of the worst conditions within the dataset with respect to temperature variations.

1.3 Temperature of fiber in amplifier stations

The temperature of the fiber when it is installed into a repeater station, for amplification, routing, or any other process, cannot be presumed stable unless verified. While many end nodes are in rooms with controlled temperature, most inline amplifiers reside in small buildings with less stringent environment control. Figure 2 shows the temperature detected at 9 of the power supply cards of the amplifiers along one of the routes between Borås and Stockholm, Sweden. The actual temperature is high since the sensor is located close to a heat emitter, but the variations are caused by a variation in room temperature. In these stations, the affected fiber length is short, but the variations are fast. Furthermore, if the link is equipped with dispersion compensated fiber, these spools will be affected by the local indoor temperature variation and may cause a difference in propagation time for signals in opposite directions (Ebenhag2007).

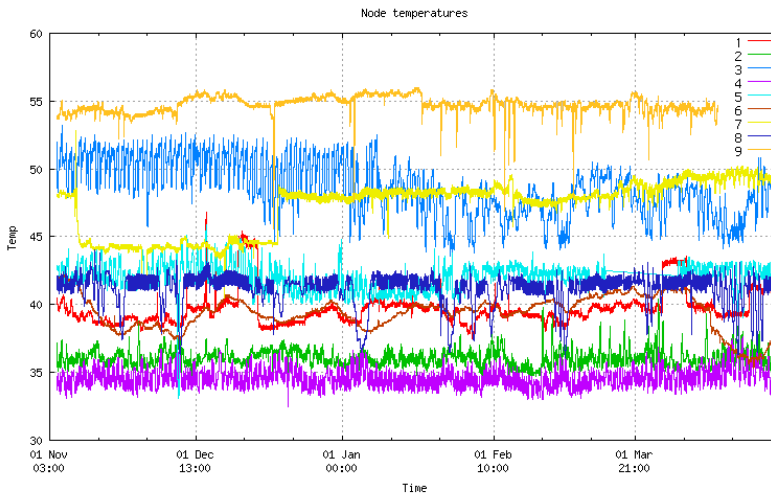

Fig. 2. Temperature measured in power supply in 9 telecom amplifier stations.

2. Time transfer

The unique characteristic of time, which also complicates the transmission, is that it is ever-changing, and the required information is both the actual time-of-day, (TOD) and the time that has passed since this information was created. It can for many applications be sufficient to estimate an approximate delay, and accept the variations, but for better accuracy than μs , the transmission time must be constantly estimated or measured and taken into account.

The output time $t_{out}(t)$ from an uncompensated fiber can be described by eq.(1)

$$t_{out}(t) = t_{in}(t) + \tau_{fiber}(t) \quad (1)$$

Where t_{in} is the time information from the transmitter clock and $\tau_{fiber}(t)$ is the varying delay through the fiber. For increased accuracy, the equation can be elaborated to:

$$t_{out}(t) = t_{in}(t) + \tau_{fiber,0} + \tau_{fiber,det}(t) + \tau_{fiber,rnd}(t) \quad (2)$$

Where $\tau_{\text{fiber},0}$ is the delay through the fiber at $t=0$, $\tau_{\text{fiber},\text{det}}(t)$ includes any delay variations that can be determined, and $\tau_{\text{fiber},\text{rnd}}(t)$ are the remaining, random variations of transfer delay. The main effort of any time transfer is to minimize the undetermined variations of the delay, through complementary measurements to the actual signal transfer.

2.1 Two-way time transfer

Two-way time transfer presumes that the system is bidirectional, and that the propagation time is equal in both directions (or at least with a deterministic and measurable difference). It can be schematically described through figure 3.

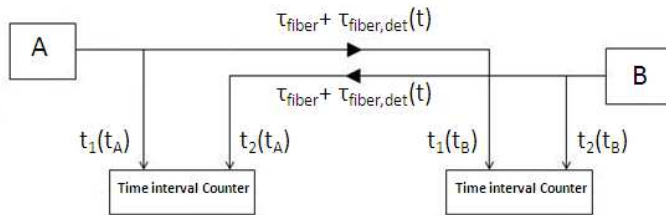

Fig. 3. Schematic system for two-way time transfer.

A well-defined signal is transmitted from point A, and the time it leaves the sender is measured with respect to the master clock A; $t_1(t_A)$. When it arrives at point B, the arrival time is measured with respect to the local clock B; $t_1(t_B)$. In addition, another well-defined signal is transmitted back from B to A, resulting in the time stamps $t_2(t_B)$ and $t_2(t_A)$. Assuming that the delay through the fiber, in both directions, is $\tau_{\text{fiber}} + \tau_{\text{fiber},\text{det}}(t)$, equations (3) - (5) is derived

$$t_1(t_B) = t_1(t_A) + \tau_{\text{fiber}} + \tau_{\text{fiber},\text{det}}(t) \quad (3)$$

$$t_2(t_A) = t_2(t_B) + \tau_{\text{fiber}} + \tau_{\text{fiber},\text{det}}(t) \quad (4)$$

$$t_1(t_B) = t_1(t_A) + t_2(t_A) - t_2(t_B) \quad (5)$$

Thus, the relationship between signal emitters A and B can be determined from measured data, and the calculations can be made at either end of the link.

Time transfer over optical fibers includes two-way transfer based on transmission on a dedicated fiber, a dedicated channel, and the piggy-back technique on existing traffic. Even though most of these techniques is based on measurements of delay, and corrections afterwards, some short distance transfer is achieved in real-time, were the output signal is corrected as the transmission characteristics change (Ebenhag2008). One-way time transfer based on two-wavelength transmission is also described in detail in this chapter.

2.1.1 Time transfer over dedicated capacity

Any transmission of a signal over a dedicated capacity requires that the network owner allocate bandwidth for the connection. It could be a channel space in a wavelength division multiplexed (WDM) system, or a whole fiber. Transmitting a signal over a dedicated fiber is to some extent the simplest technology, since there are no interference from adjacent

channels that has to be taken into account, and the modulation format can be chosen arbitrarily. (Smotlacha; Amemiya). There are no major differences to transmit over a dedicated channel, i.e. using one wavelength in the vicinity of others, with the exception of any constraints induced by interchannel interference.

2.1.2 Time transfer over shared capacity

To minimize any unnecessary bandwidth allocation, it is advantageous to operate on an active channel, where data-communication uses all, or at least most of, the available capacity. An early approach used the data transmission of SONET OC-3 at 155,52 Mbit/s and locked this repetition rate to the master 5 MHz. Furthermore, a synchronization signal was generated in the data-stream at 1 pps (Calhoun). Thus, it would be possible to share the time and frequency transfer capacity with active communication, where time transfer only need a well defined sequence once per second.

An even less bandwidth consuming technique uses an existing well defined sequence of a digital communication protocol for time transfer (Emardson, Ebenhag2010a). It can thereby be called a 'piggy-back' technique. Time transfer using this technique relies on an existing, continuous transmission of digital data. In this case, a sync sequence is detected in all locations of the two-way transmission, and the time stamp defining of the occasions is transfer separately, as a low bandwidth signal. The piggy back technique has been presented at 10 Gbit/s on the SONET and SDH protocol, where data is transmitted in 125 μ s long frames and every frame start with a sequence of 192 A1 bytes, followed by 192 A2 bytes¹. If every occurrence of a frame start sequence is detected at both transmitters and both receivers of a fiber link, and all data is sent to a computational node, the necessary timing information can be calculated for accurate time transfer. The repetitive structure of the transmission enables a simplification, where it is sufficient to detect one sequence/s, and with the knowledge of 125 μ s interval between sequences, time transfer can be extracted even though the four measurements correspond two four different sequences.

2.2 One-way time transfer

When the surrounding temperatures of the fiber vary, it affects both the transfer time and the dispersion, which can be measured at the receiving end of the fiber. Since there is an unambiguous relationship between these two parameters, the correlation between them can be used to estimate one from the other. The measurement technique for fiber dispersion is well known (Vella) and the variation with respect to temperature has been studied previously (Hatton; Walter). This property is utilized in the one-way time transfer, and the scale coefficient for a specific fiber link must be individually characterized.

In a fully operational solution, the time from the Master clock is distributed to a Slave clock, with a precision better than what it would be in the case of a single signal was transmitted. The system is described schematically in figure 4.

At the transmitting end, a Master clock controls two lasers, and at the receiving end a slave clock makes an interpretation of the two signals, received after transmission over two wavelengths, to enhance its precision. The thin and thick lines are electrical cables and optical fibers, respectively, and the open line on top symbolizes the outdoor transmission fiber of arbitrary length while the dashed regions indicates indoor environment.

¹ A1 = [11110110], A2 = [01101000]

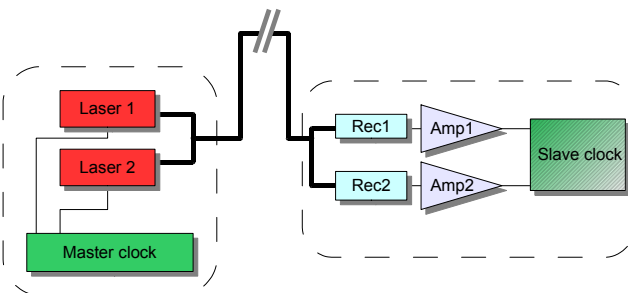

Fig. 4. Schematic system for one-way fiber based time transfer.

2.2.1 Theory

The theory for one-way dual wavelength optical fiber time and frequency transfer is based on the transit time τ for propagation of a single mode in a fiber (Cochrane) expressed as the group velocity for a certain distance L and the wavelength λ .

$$\tau = \frac{L}{c} \left(n - \lambda \frac{dn}{d\lambda} \right) \tag{6}$$

where n is the refractive index and c is the speed of light in vacuum. The transit time τ , sometimes known as the group delay time, in a fiber is thus dependent on the refractive index and the wavelength. This means that two different wavelengths will propagate at different velocity in the same fiber. A standard single mode fiber is temperature dependent, to an extent shown in previous studies (Walter), and the most important factor to include in the calculations. By calculating the derivative of the transit time with respect to temperature, both wavelength and refractive index will be taken into account as follows:

$$\left. \frac{d\tau}{dT} \right|_{\lambda_N} = \frac{1}{c} \left(\frac{dL}{dT} \left(n - \lambda \frac{dn}{d\lambda} \right) + L \left(\frac{dn}{dT} - \lambda \frac{d^2n}{dTd\lambda} \right) \right) \quad N=1,2 \tag{7}$$

The variation in transit time as a function of temperature can thus be calculated where λ_N $N=1,2$; represents the two wavelengths. The equations for the two wavelengths are subtracted from each other, resulting in:

$$\left. \frac{d\tau}{dT} \right|_{\lambda_1 - \lambda_2} = \frac{1}{c} \left(\frac{dL}{dT} \left((n_{\lambda_1} - n_{\lambda_2}) + \lambda_2 \frac{dn_{\lambda_2}}{d\lambda_2} - \lambda_1 \frac{dn_{\lambda_1}}{d\lambda_1} \right) + L \frac{d}{dT} \left((n_{\lambda_1} - n_{\lambda_2}) + \lambda_2 \frac{dn_{\lambda_2}}{d\lambda_2} - \lambda_1 \frac{dn_{\lambda_1}}{d\lambda_1} \right) \right) \tag{8}$$

This expression shows how the refractive indices of the two wavelengths are influenced by temperature, and based on this the variations in propagation time can be calculated. The time transfer technique uses the property that the variations are different, but correlated, which also is supported by experimental results later on.

2.2.2 Numerical simulations

The difference in transit time through the fiber will, as shown in eq (8) depend on the variation of length, L , and the variation in refractive index, n . Both these effects will affect the chromatic dispersion of the fiber, but through different properties.

2.2.2.1 Variations in refractive index

The refractive index of the fiber can be described by eq. (9), called the Sellmeier equation (Sellmeier; Ghosh)

$$n^2 = A + \frac{B}{1-C/\lambda^2} + \frac{D}{1-E/\lambda^2} \quad (9)$$

Where λ is the wavelength in μm and the Sellmeier coefficients A, B, C, D and E have been empirically fitted with respect to temperature, T, for different glasses. Using the data for fused Silica (Ghosh), results in:

Sellmeier coefficient	Fitted constants (SiO ₂)
A	$6,90754 \cdot 10^{-6}T + 1,31552$
B	$2,35835 \cdot 10^{-5}T + 0,788404$
C	$5,84758 \cdot 10^{-7}T + 1,10199 \cdot 10^{-2}$
D	$5,48368 \cdot 10^{-7}T + 0,91326$
E	100

Table 1. Empirically fitted values for Sellmeier coefficients

From these equations, the material dispersion can be calculated as²:

$$D_M(\lambda) = \frac{1}{cn} \left[-\frac{4}{\lambda^5} \left\{ \frac{BC^2}{(1-C/\lambda^2)^3} + \frac{DE^2}{(1-E/\lambda^2)^3} \right\} + \lambda \left(\frac{dn}{d\lambda} \right)^2 + 3n \frac{dn}{d\lambda} \right] \quad (10)$$

where

$$\frac{dn}{d\lambda} = -\frac{1}{n\lambda^3} \left(\frac{BC}{(1-C/\lambda^2)^2} + \frac{DE}{(1-E/\lambda^2)^2} \right) \quad (11)$$

Using these parameters, the material dispersion of SiO₂ is calculated and shown in figure 5. It may vary slightly in communication fibers where the silica is doped with small amount of other substances. Nevertheless the overall behavior is comparable.

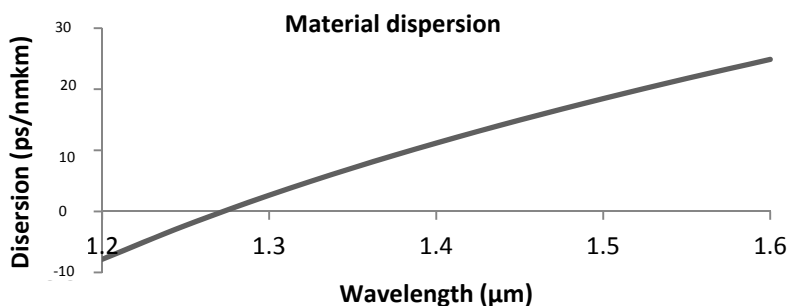

Fig. 5. Calculation of material dispersion in Fused Silica at 20°C.

² This equation is corrected with respect to the reference, where the left side of the equation begins with a “-”.

From the equations (6)-(11), it is possible to estimate the amount of propagation time variations with respect to temperature. Assuming a fiber where material dispersion is dominant (as is the case in standard single mode fiber), at a length of 20 km and measurement at 1530 nm and 1560 nm, the result is shown in figure 6. The slope of the calculated dispersion is $-0,0016$ ps/nmkm°C, which is comparable to previously reported results $-0,0025$ ps/nmkm°C for NZDSF (non-zero dispersion shifted fiber) and $-0,0038$ ps/nmkm°C for large core fiber (Walter).

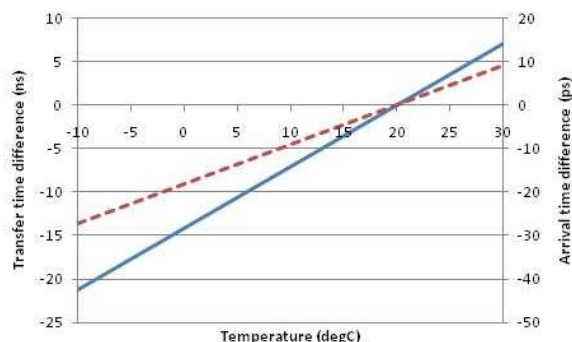

Fig. 6. Temperature dependence of transfer time (solid blue, left axis) and arrival time difference (dashed red, right axis).

The solid curve (left axis) shows the transfer time for a signal at 1530 nm, and the dashed curve shows the arrival time difference for two signals at 1530 nm and 1560 nm. Both curves are normalized with respect to the value at 20°C, and it is apparent that the propagation time within a single, 20 km long fiber varies with almost 30 ns when affected by 40°C temperature difference. The calculations also suggests that this variation can be detected and compensated for, using transmission at two wavelengths and a measurement system that can measure time variations on ps level with sufficient precision.

2.2.2.2 Variations of length

This evaluation assumes that the cabling or mounting will stretch the fiber at increasing temperature, however leaving the volume intact. The variations in dimensions of the glass are assumed to be negligible. If the core of the fiber is modelled as a glass cylinder, of length L and diameter d , a geometrical approach gives that the variation in temperature will change the length with $\Delta L(T-T_0)$ and the diameter with $\Delta d(T-T_0)$, such that

$$\frac{\Delta d(T-T_0)}{d} = -\frac{\Delta L(T-T_0)}{2L} \quad (12)$$

where T is the temperature and T_0 is the reference temperature.

This change in diameter will change the dispersion according to the variation in waveguide dispersion (Gloge; Keiser):

$$D_W(\lambda) = -\frac{n_2 \Delta}{c\lambda} V \frac{d^2(Vb)}{dV^2} \quad (13)$$

where n_2 is the refractive of the cladding and Δ is the relative difference of refractive index in the core and in the cladding. V and b are the normalized frequency and the normalized propagation constant, respectively, and can be found through:

$$V = ka\sqrt{n_1^2 - n_2^2} \cong kan_2\sqrt{2\Delta} \quad (14)$$

$$b = \frac{(\beta/k)^2 - n_2^2}{n_1^2 - n_2^2} \quad (15)$$

where k is the free-space propagation constant, β is the propagation constant and $a = d/2$ is the fiber core radius. From these equations, it is apparent that fibers with notable waveguide dispersion, e.g. dispersion shifted fibers, dispersion compensating fibers etc, will have different response to a change in diameter d , than standard fibers where material dispersion is dominant. However, this response must be evaluated for each fiber design, since the term $V(d^2(Vb)/dV^2)$ is between 0 and 1,2 with a maximum at $V \approx 1,2$. These equations show nevertheless that the system of detecting a variation in propagation time through a fiber with substantial waveguide dispersion is possible, but must be optimized for the actual fiber parameters.

2.2.3 Experimental setup

The experimental setup for the verification of the proposed time and frequency transfer technique is shown in figure 7. Two lasers at wavelengths 1530 nm and 1560 nm are directly modulated by a 10MHz reference oscillator and the light is launched into the SMF through a 50/50 power combiner. The reference oscillator is a frequency stabilized H-maser used as Master clock. In the experiment, the oscillator is also used as reference to the measurement equipment, connected as indicated by the lower line, in order to evaluate the technique. Furthermore, to increase sensitivity, the signal from the oscillator is connected to the LO-ports of the two double balanced mixers at the output of the transmitted signal paths. The equipment within the dashed frame is held within a controlled environment, and the spools of SMF are placed outdoors together with a temperature sensor for monitoring and comparison with transfer time variations. The total sum of fiber length is 12,761.5 m, including 187.6 m of transfer fiber between the lab and the outdoor fiber spools. At the receiving end, the two wavelengths are separated in a 50/50 power splitter, filtered in optical band-pass filters and

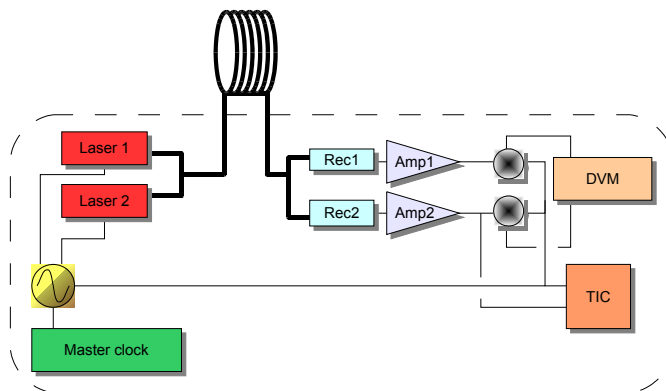

Fig. 7. Experimental setup. Rec1 and Rec2 include optical pre-amplification, optical band pass filter, photodiode and electrical trans-impedance amplifier. Amp1 and Amp2 are electrical amplifiers, DVM digital voltmeter and TIC is time-interval counter. Thin lines symbolize electrical wires and thick lines optical fibers.

detected in two 10 Gb/s p-i-n receivers. The signals are amplified and connected to the RF ports of two double balanced mixers. One of the signals is also divided and connected to the reference time interval counter (TIC), which measures the total propagation time between the transmitter and the receiver. The output of the TIC is interpreted as the precision of an uncompensated one-way time and frequency transmission. By measuring the voltages of the two output ports of the mixers in a digital voltmeter (DVM), a correction signal is achieved and can be used for a real-time delay control of the uncompensated signal.

2.2.4 Experimental results

In Figure 8, the result from six days of measurement is plotted over time with the one-way method (blue, left scale), and the estimated delay from the two-wavelength time difference (red, left scale). The estimated transfer time T_{est} is made through empirical fitting, and follows the equation:

$$T_{est} = F_1 \arccos(I_1 - I_2) + F_2 \tag{16}$$

where I_1 and I_2 are the output voltages from the two mixers, normalized with the maximum level of each output. The numerical values of the fitting parameters, F_1 and F_2 resulting in the lowest residual error (rms) are shown in table 2.

Compensation parameter	Fitted constant
F_1	$1,58 \cdot 10^{-8}$ s
F_2	$1,71 \cdot 10^{-9}$ s

Table 2. Empirically fitted compensation constants.

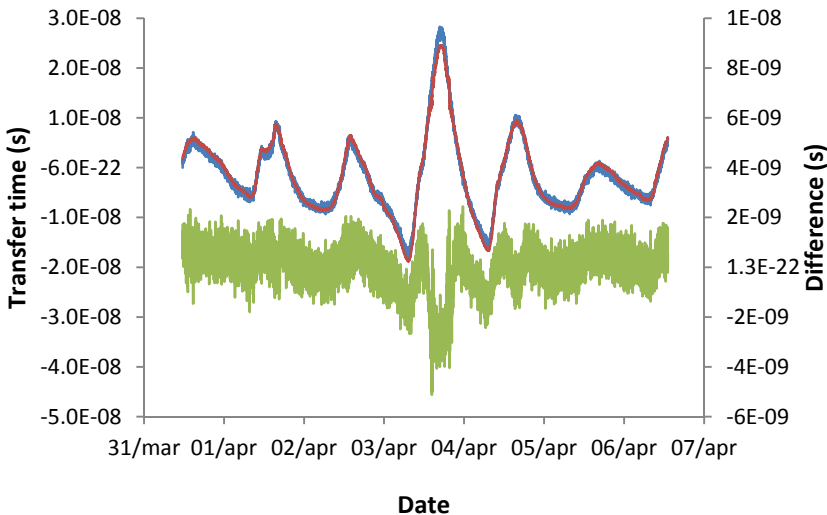

Fig. 8. Measured variations during six days. The uncompensated one-way transfer time (blue, left axis) is compared with the compensation signal from two-wavelength difference measurement (red, left axis). The residual error (green, right axis) is an order of magnitude lower.

The difference between the measured time delay and the compensation signal is shown in the final curve (green, right axis). The stability of the output signal is thereby enhanced from 7,7 ns rms to 0,9 ns rms.

3. Frequency transfer

While time transfer stability is compensated for the actual difference in optical path length, the frequency transfer is sensitive for how fast the delay changes. In comparison to equation (1), the output frequency of an uncompensated fiber is described by:

$$f_{out}(t) = f_{in}(t) + \frac{d\varphi(t)}{dt} \quad (17)$$

where $f_{in}(t)$ and $f_{out}(t)$ are the momentaneous input and output frequencies, respectively, and $\tau(t)$ is the time varying delay through the fiber. The derivative $d\varphi(t)/dt$ arises from the change in $\tau(t)$ with respect to the period of the microwave frequency, such that

$$\frac{d\varphi(t)}{dt} = 2\pi f_{in}(t) \frac{d\tau(t)}{dt} \quad (18)$$

3.1 Optical transfer of microwave frequency

When the fiber link is used to transfer a microwave frequency modulated on top of an optical carrier, this variation will only be notable over long distances, or if the fiber is installed in harsh environment (open air, sunlit roofs etc.). A two-way frequency transfer will then schematically be implemented as shown in figure 9. The control equipment adjusts the input signal to the phase modulator of the transmitted and returned signal, such that the total phase variation after a round-trip in the fiber link is cancelled out.

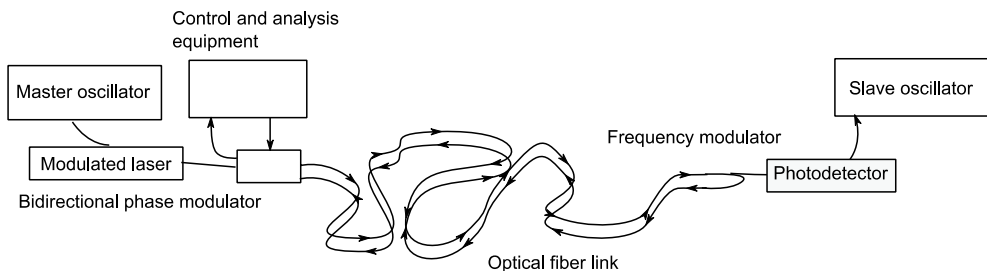

Fig. 9. Schematic frequency transfer in microwave domain.

3.2 Optical comb

One key invention for optical frequency transfer, as well as for other techniques, is the optical comb (KVA). By generating short optical pulses with a constant repetition rate, the corresponding spectrum will consist of a comb of equidistant peaks. T. Hänsch and J. Hall managed in to broaden this spectrum to exceed one octave of optical tones, which enabled new measurements (Hall; Holzwarth).

Figure 10 illustrates the comb structure of the optical spectrum. If one of the lowest frequencies in the spectrum, ν_l , is doubled, it will create a new frequency, $2\nu_l$, close to one of the highest in the comb, ν_d . Since the difference between the two frequencies is known,

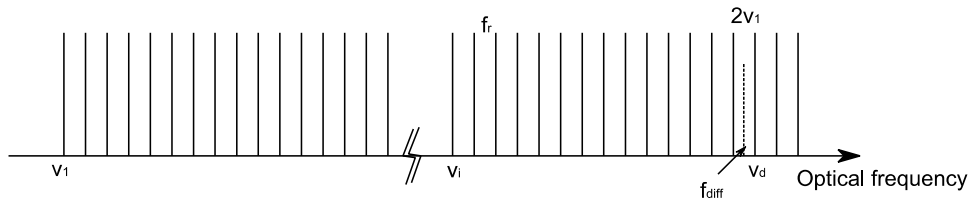

Fig. 10. Schematic spectrum of optical comb spanning one octave.

every optical frequency in the comb can be determined at comparable accuracy of a microwave frequency. With the parameters f_r and f_{diff} describing the repetition frequency of the pulses creating the comb, and the measured difference frequency between $2\nu_1$ and ν_d , respectively, equations (19) and (20) results in the determination of an arbitrary optical frequency ν_i .

$$\vartheta_i = \vartheta_1 + N_i f_r \tag{19}$$

$$\vartheta_1 = N_d f_r + f_{diff} \tag{20}$$

3.3 Optical frequency transfer

To be able to compare two optical clocks at different locations, optical frequency transfer over fiber is the only option. Figure 11 shows the basic technique, but does not cover all details. It can be described as follows. The optical clock A emits a wavelength corresponding to the atom or ion in use, usually not within the telecommunication bands. Therefore, an ultra-stable wavelength at approximately 1550 nm is also created in lab A. Through an optical comb, the frequency relation between these two wavelengths can be determined.

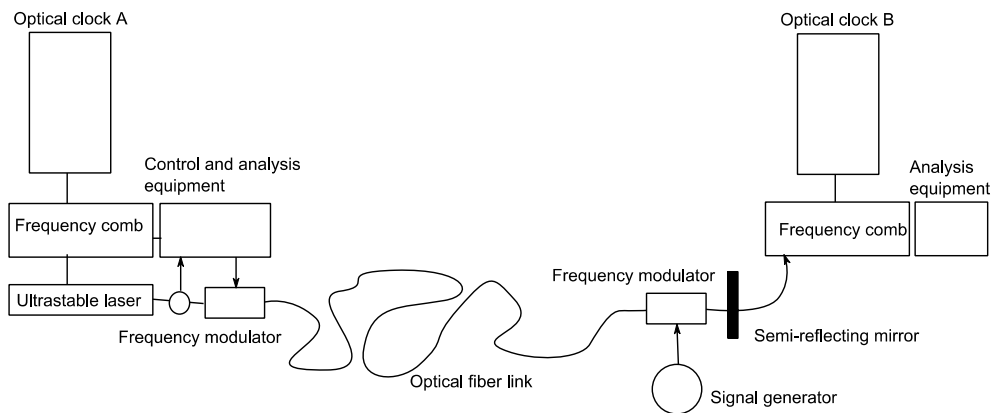

Fig. 11. Schematic setup for optical frequency transfer.

The light from the ultra-stable laser is launched through an optical frequency modulator (usually an acousto-optical modulator) and transferred through the fiber to lab B, where another frequency modulator is passed. A semi-reflecting mirror (often the Fresnel-reflection of the glass-air interface is sufficient) lets the light return along the same path. After the return to lab A, the received signal is compared with the transmitted, and the

modulation is adjusted to counteract any phase variations induced through the fiber. The modulator in lab B is used to offset the return signal, whereas scattering effects in the fiber will deteriorate the signal when sent at the same wavelength in both directions.

Finally, the light entering lab B is stable with respect to variations in the fiber, and can be compared with the light emitted from Optical clock B, through another optical comb. Since all this comparison must be performed through analog signal interference in the optical domain, the ultra-stable frequency transfer must be performed in real-time, where any perturbation in the fiber must be corrected on the fly. It is also significant that where a microwave frequency can be transferred between two labs through a fiber pair, with the addition of an increased uncertainty, optical frequency transfer must be performed through a bi-directional two-way transfer in a single fiber.

Successful experiments with optical frequency transfer has been reported from several groups, bridging distances up to 480 km and connecting labs with optical clocks. (Jiang; Foreman; Terra).

4. Conclusion

In conclusion, fiber optics is shown to be an advantageous channel for precise time and frequency transfer, both for comparing next generation optical clocks and to support the emerging users of network time with high precision. For long baseline comparisons, there may however be a need for new components and connection schemes, and the development towards better and more precise links is in its beginning. The ultimate target to reach trans-Atlantic and trans-Pacific distances will require much future effort, however definitely achievable.

5. References

- Amemiya, M.; Imae, M.; Fujii, Y.; Suzuyama, T. and Ohshima, S. (2005) "Time and Frequency Transfer and Dissemination Methods Using Optical Fiber Network", *Topical Meeting on Precise Time and Time Interval, PTTI'05*, paper 99 2005
- BIPM (2010), "BIPM Annual Report on Time Activities", Bureau International Des Poids et Mesures, Vol 5, 2010. http://www.bipm.org/en/scientific/tai/time_ar2010.html.
- Calhoun, M.; Kuhnle, P.; Sydnor, R.; Stein, S. & Gifford, A. (1996) "Precision Time and Frequency Transfer Utilizing SONET OC-3", *Proceedings of the 28th Topical Meeting on Precise Time and Time Interval*, pp 339 - 348, Dec 3-5, Reston, Va, 1996.
- Chaplain, C.T. "Global Positioning System, Significant Challenges in Sustaining and Upgrading Widely Used Capabilities", United States Government Accountability Office report GAO-09-670T, 2009
- Cochrane, K.; Bailey, J. E.; Lake P. & Carlson, A. (2001) "Wavelength-dependent measurements of optical-fiber transit time, material dispersion, and attenuation" *Applied Optics*, Vol 40, No 1, January 2001
- Ebenhag, S.-C.; Jarlemark, P.; Hedekvist, P.O. & Emardson, R. (2007), " Time Transfer Using an Asynchronous Computer Network: an Analysis of Error Sources" *European Frequency and Time Forum, EFTF'07*, 2007.
- Ebenhag, S.C.; Hedekvist, P.O.; Rieck, C.; Skoogh, H.; Jarlemark, P. & Jaldehag, K. (2008) "Evaluation of Output Phase Stability in a Fiber Optic Two-Way Frequency

- Distribution System", Proceedings of the Precise Time and Time Interval Meeting 2008. Paper 11 (2008).
- Ebenhag, S.C.; Hedekvist, P.O.; Jarlemark, P.; Emardson, R.; Jaldehag, K.; Rieck C. and Löthberg P. (2010a) "Measurements and Error Sources in Time Transfer Using Asynchronous Fiber Network", *IEEE Trans. Instr. Meas.*, vol. 59, pp. 1918 - 1924, (2010)
- Ebenhag, S.C. and Hedekvist, P.O. (2010b) "Fiber Based One-way Time Transfer with Enhanced Accuracy", *European Frequency and Time Forum EFTF'10*, 2010
- Emardson, R.; Hedekvist, P.O.; Nilsson, M.; Ebenhag, S.C.; Jaldehag, K.; Jarlemark, P.; Rieck, C.; Johansson, J.; Pendrill, L.; Löthberg P. and Nilsson, H. (2008) "Time Transfer by Passive Listening over a 10 Gb/s Optical Fiber", *IEEE Trans. Instr. Meas.*, vol. 57, pp. 2495 - 2501 (2008)
- Foreman, S.M.; Ludlow, A.D.; de Miranda, M.H.G.; Stalnaker, J.E.; Diddams, S.A. & Ye, J.. (2007), "Coherent optical phase transfer over a 32-km fiber with 1 s instability $<10^{-17}$ ". *Physical Review Letters*. 2007 Oct 12;99(15):153601. Epub 2007 Oct 9
- Ghosh, G.; Endo M. and Iwasaki, T.(1994) "Temperature-Dependent Sellmeier Coefficients and Chromatic Dispersions for Some Optical Fiber Glasses", *J. Lightwave Technol.* Vol. 12, pp 1338 - 1342, 1994.
- Gloge, D. (1971) "Dispersion in weakly guided fibers", *Appl. Opt.*, vol 10, pp 2442 - 2445, Nov. 1971.
- Hall, J.L.; Ye, J.; Diddams, S.A.; Ma, L.-S.; Cundiff S.T. & Jones, D.J.(2001) "Ultrasensitive spectroscopy, the ultrastable lasers, the ultrafast lasers, and the seriously nonlinear fiber: a new alliance for physics and metrology", *IEEE J. Quant. Electr.* 37, 1482, 2001
- Hanssen, J.; Crane, S. & Ekstrom, C. (2011) "One-way Temperature Compensated Fiber Link", *European Frequency and Time Forum EFTF'11*, 2011.
- Hatton, W.H. & Nishimura, M., "Temperature dependence of chromatic dispersion in single mode fiber", *Journal of Lightwave Technology*, Vol LT-4, No10, October 1
- Holzwarth, R.; Zimmermann, M.; Udem, Th. & Hänsch, T.W. (2001)"Optical clockworks and the measurement of laser frequencies with a mode-locked frequency comb" *IEEE J. Quant. Electr.* 37, 1493, 2001
- IRIG (2004), "IRIG Serial Time Code Formats", Timing Committee, Telecommunications and Timing Group, Range Commanders Council, IRIG Standard 200-04.
- Jefferts, S.R.; Weiss, M.; Levine, J.; Dilla, S. & Parker, T. E. (1996) "Two-Way Time Transfer through SDH and Sonet Systems", *European Frequency and Time Forum EFTF'96*, 1996
- Jiang, H.; Kéfélian, F.; Crane, S.; Lopez, O.; Lours, M.; Millo, J.; Holleville, D.; Lemonde, P.; Chardonnet, Ch.; Amy-Klein, A. & G. Santarelli, G. (2008)" Long-distance frequency transfer over an urban fiber link using optical phase stabilization" *J. OSA B*, Vol. 25, Issue 12, pp. 2029-2035 (2008)
- Kéfélian, F.; Jiang, H.; Lemonde P. & Santarelli, G. (2009): "Ultralow-frequency-noise stabilization of a laser by locking to an optical fiber-delay line", *Optics Lett.*, Vol 34, No 7, 2009
- Keiser, G. (1991), "Optical Fiber Communication, 2nd ed", McGraw-Hill, 1991
- Kihara, M.; Imaoka, A.; Imae, M. & Imamura, K. (2001) "Two-Way Time Transfer through 2.4 Gb/s Optical SDH Systems", *IEEE Trans. Instr. Meas.*, vol. 50, pp. 709-715, 2001

- KVA, (2005), "What limits the measurable?" and "Quantum-mechanical theory of optical coherence - Laser-based precision spectroscopy and optical frequency comb techniques", Royal Swedish Academy of Sciences (Kungliga Vetenskapsakademien), Supplementary information on the Nobel Prize in Physics 2005, http://nobelprize.org/nobel_prizes/physics/laureates/2005/info.pdf and http://nobelprize.org/nobel_prizes/physics/laureates/2005/phyado05.pdf
- NCRS, National Resources Conservation Service, Data available at <http://www.wcc.nrcs.usda.gov/scan/>
- NSTAC, "NSTAC Report to the President on Commercial Communications Reliance on the Global Positioning System (GPS)", National Security Telecommunications Advisory Committee (NSTAC) Publications, Feb. 28, 2008
- OICM "The International System of Units (SI)", Report from Organisation Intergouvernementale de la Convention de Metre, 8th ed. 2006
- Paschotta, R.; (2008), "Encyclopedia of Laser Physics and Technology Volume 1 and 2", Wiley- VCH Verlag GmbH & Co, Weinheim
- Sellmeier, W. (1871) "Zur Erklärung der abnormen Farbenfolge im Spectrum einiger Substanzen", *Annalen der Physik und Chemie* 219, 272-282, 1871.
- Smotlacha, V.; Kuna, A. & Mache, W. (2010) "Time Transfer Using Fiber Links", *European Frequency and Time Forum, EFTF'10*, 2010
- Terra, O.; Grosche, G. & Schnatz, H.: "Brillouin amplification in phase coherent transfer of optical frequencies over 480 km fiber". *Opt. Express* 18, 16102-16111 (2010).
- Vella, P.J.; Garrel-Jones, P.M. & Lowe, R.S. (1985), "Measuring Chromatic Dispersion of Fibers", US Patent 4551019, Nov. 5, 1985.
- Walter, A. & Schaefer, G. (2002), "Chromatic Dispersion Variations in Ultra-Long-haul Transmission Systems Arising from Seasonal Soil Temperature Variations", *Conference on Optical Fiber Communication, OFC'02*, 2002.

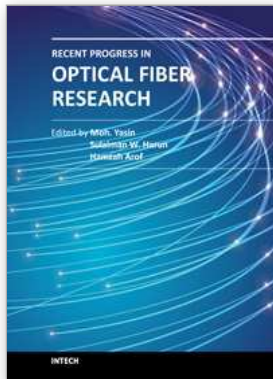

Recent Progress in Optical Fiber Research

Edited by Dr Moh. Yasin

ISBN 978-953-307-823-6

Hard cover, 450 pages

Publisher InTech

Published online 25, January, 2012

Published in print edition January, 2012

This book presents a comprehensive account of the recent progress in optical fiber research. It consists of four sections with 20 chapters covering the topics of nonlinear and polarisation effects in optical fibers, photonic crystal fibers and new applications for optical fibers. Section 1 reviews nonlinear effects in optical fibers in terms of theoretical analysis, experiments and applications. Section 2 presents polarization mode dispersion, chromatic dispersion and polarization dependent losses in optical fibers, fiber birefringence effects and spun fibers. Section 3 and 4 cover the topics of photonic crystal fibers and a new trend of optical fiber applications. Edited by three scientists with wide knowledge and experience in the field of fiber optics and photonics, the book brings together leading academics and practitioners in a comprehensive and incisive treatment of the subject. This is an essential point of reference for researchers working and teaching in optical fiber technologies, and for industrial users who need to be aware of current developments in optical fiber research areas.

How to reference

In order to correctly reference this scholarly work, feel free to copy and paste the following:

Per Olof Hedekvist and Sven-Christian Ebenhag (2012). Time and Frequency Transfer in Optical Fibers, Recent Progress in Optical Fiber Research, Dr Moh. Yasin (Ed.), ISBN: 978-953-307-823-6, InTech, Available from: <http://www.intechopen.com/books/recent-progress-in-optical-fiber-research/time-and-frequency-transfer-in-optical-fibers>

INTECH
open science | open minds

InTech Europe

University Campus STeP Ri
Slavka Krautzeka 83/A
51000 Rijeka, Croatia
Phone: +385 (51) 770 447
Fax: +385 (51) 686 166
www.intechopen.com

InTech China

Unit 405, Office Block, Hotel Equatorial Shanghai
No.65, Yan An Road (West), Shanghai, 200040, China
中国上海市延安西路65号上海国际贵都大饭店办公楼405单元
Phone: +86-21-62489820
Fax: +86-21-62489821

© 2012 The Author(s). Licensee IntechOpen. This is an open access article distributed under the terms of the [Creative Commons Attribution 3.0 License](#), which permits unrestricted use, distribution, and reproduction in any medium, provided the original work is properly cited.