

TIME LAG AND SOIL PERMEABILITY IN GROUND-WATER OBSERVATIONS



BULLETIN NO. 36

**WATERWAYS EXPERIMENT STATION
CORPS OF ENGINEERS, U. S. ARMY**

VICKSBURG, MISSISSIPPI

**TIME LAG AND SOIL PERMEABILITY
IN GROUND-WATER OBSERVATIONS**



BULLETIN NO. 36

WATERWAYS EXPERIMENT STATION
CORPS OF ENGINEERS, U. S. ARMY
VICKSBURG, MISSISSIPPI

APRIL 1951

CONTENTS

	Page
PREFACE	i
ACKNOWLEDGEMENTS.	ii
NOTATION.	v
INTRODUCTION	1
 PART I: GROUND-WATER CONDITIONS AND OBSERVATIONS	
Irregularities and Variations.	3
Sources of Error in Measurements.	3
Hydrostatic time lag.	4
Stress adjustment time lag.	4
General instrument errors.	4
Seepage along conduits	4
Interface of liquids.	6
Gas bubbles in open systems	6
Gas bubbles in closed systems	6
Gas bubbles in soil.	7
Sedimentation and clogging.	7
Erosion and development.	7
Summary comments	8
 PART II: THEORY OF TIME LAG	
The Basic Hydrostatic Time Lag	9
Applications for Constant Ground-Water Pressure.	10
Applications for Linearly Changing Pressures	13
Applications for Sinusoidal Fluctuating Pressures.	16
Corrections for Influence of the Hydrostatic Time Lag.	19
Influence of the Stress Adjustment Time Lag	21
Initial disturbance and stress changes	22
Transient consolidation or swelling of soil	23
Volume changes of gas in soil	26
Normal operating conditions.	28

CONTENTS (Cont'd)

	Page
PART III: DATA FOR PRACTICAL DETERMINATION AND USE OF TIME LAG	
Flow through Intakes and Well Points	30
Influence of Anisotropic Permeability	32
Computation of Time Lag for Design Purposes	35
Examples of Field Observations and Their Evaluation	38
Logan International Airport, Boston.	38
Vicinity of Vicksburg, Mississippi.	39
Determination of Permeability of Soil in Situ	43
Basic formulas	43
Examples of applications.	45
Advantages and limitations.	46
REFERENCES	48

NOTATION

- x** Distance from ref.level to piezometer level for steady state,cm.
y Distance from ref. level to piezometer level, transient state,cm.
z Distance from reference level to the outside piezometric level,cm.
- x_0
 y_0 Values of $x, y,$ and z for $t=0,$ cm.
 z_0
- x_a Amplitude of fluctuating piezometer levels for steady state,cm.
 z_a Amplitude of fluctuating outside piezometric levels,cm.
- h** Increment change in active head,cm.
H Active head, $H = z - y,$ cm.
H₀ Active head for $t=0,$ cm.
H_c Constant piezometric head, cm.
- h'** Increment change in transient differential head,cm.
H' Transient differential head, $H' = y - x,$ cm.
H'₀ Transient differential head for $t=0,$ cm.
- A** Area of casing, piezometer, manometer, or pressure cell,cm².
d Diameter of piezometer, manometer, or pressure cell,cm.
D Diameter of effective intake, boring, or well point,cm.
e Base of natural logarithms, no dimension.
E Equalization ratio, $E = (H_0 - H) / H_0$ no dimension.
F Intake shape factor, from $q = F k H,$ cm.
L Length of effective intake or well point,cm.
- k** Coefficient of permeability, cm/sec.
k_h Coefficient of horizontal permeability, undisturbed soil, cm/sec.
k_m Mean coefficient of permeability, $k_m = \sqrt{k_h \cdot k_v},$ cm/sec.
k_v Coefficient of vertical permeability, undisturbed soil,cm/sec.
k'_v Coefficient of vertical permeability, soil in casing,cm/sec.
m Transformation ratio, $m = \sqrt{k_h/k_v},$ no dimension.
- q** Rate of flow at time t and head $H,$ cm³/sec.
q₀ Rate of flow at time $t=0$ and head $H_0,$ cm³/sec.
t Time, seconds unless otherwise indicated.
 s Seconds)
 m Minutes)
 h Hours) Used only in Figs. 14,16,17.
 d Days)
- t_s** Phase shift of sinusoidal wave, seconds unless otherwise indicated.
T Basic time lag, $T = V/q,$ seconds unless otherwise indicated.
T_w Period of sinusoidal wave, seconds unless otherwise indicated.
V Total volume of flow required for pressure equalization,cm³.
- α** Rate of linear change in pressure, cm/sec.
γ Unit weight,g/cm³.
ε Deflection of diaphragm in pressure cell,cm.

PREFACE

With the advance of soil mechanics and its applications in the design and construction of foundation and earth structures, the influence of ground-water levels and pore-water pressures is being considered to a much greater extent than a decade or two ago. Rapid and reliable determination of such levels and pressures is assuming increasing importance, and sources of error which may influence the measurements must be eliminated or taken into account.

A review of irregularities in ground-water conditions and the principal sources of error in ground-water observations is presented in the first part of this paper. Many of these sources of error can be eliminated by proper design, installation, and operation of observation wells, piezometers, or hydrostatic pressure cells. However, other sources of error will always be present and will influence the observations to a greater or lesser degree, depending on the type of installation and the soil and ground-water conditions. Conspicuous among the latter sources of error is the time lag or the time required for practical elimination of differences between hydrostatic pressures in the ground water and within the pressure measuring device.

Theoretical and experimental methods for determination of the time lag and its influence on the results of ground-water observations are proposed in the second part of the paper. Simplifications are obtained by introducing a term called the basic time lag, and solutions are presented for both static, uniformly changing, and fluctuating ground-water conditions. The influence of a secondary or stress adjustment time lag, caused by changes in void ratio or water content of the soil during the observations, is discussed.

The third part of the paper contains data which will assist in the practical application of the proposed methods. Formulas for determination of the flow of water through various types of intakes or well points are summarized and expanded to include conditions where the coefficients of the vertical and horizontal permeability of the soil are different. Examples of computations and a table facilitate preliminary estimates of the basic time lag for the principal types of installations and soils, and determination of the actual time lag is illustrated by several examples of field observations and their evaluation.

Determination of the coefficients of vertical and horizontal permeability for the soil in situ by means of time lag observations is theoretically possible and is discussed briefly in the closing section of the paper. Such field determinations of permeability have many potential advantages, but further researches needed in order to eliminate or determine the influence of various sources of error.

An abstract of the paper was presented in January 1949 at the Annual Meeting of the American Society of Civil Engineers, and a limited number of copies of the first draft were distributed. In this final version of the paper the individual sections have been rearranged and amplified to some extent, and some new sections have been added.

ACKNOWLEDGEMENTS

The writer wishes to express his appreciation of the many valuable suggestions made by Messrs. Reginald A. Barron, Stanley J. Johnson, and the Reports Branch of the Waterways Experiment Station in course of their reviews of the paper.

TIME LAG AND SOIL PERMEABILITY IN GROUND-WATER OBSERVATIONS

by

M. Juul Hvorslev*

INTRODUCTION

Accurate determination of ground-water levels and pressures is required, not only in surveys of ground-water supplies and movements, but also for proper design and construction of most major foundation and earth structures. The depth to the free ground-water level is often a deciding factor in the choice of types of foundations, and it governs the feasibility of and the methods used in deep excavations. A recent fall or rise in ground-water levels may be the cause of consolidation or swelling of the soil with consequent settlement or heaving of the ground surface and foundations. The existence of artesian or excess pore-water pressures greatly influences the stability of the soil; determination of pore-water pressures permits an estimate of the state or progress of consolidation, and it is often essential for checking the safety of slopes, embankments, and foundation structures. In general, determination of both free ground-water levels and pore-water pressures at various depths is usually a necessary part of detailed subsurface explorations, and the observations are often continued during and for some period after completion of foundation and earth structures.

Ground-water levels and pore-water pressures are determined by means of borings, observation wells, or various types of piezometers and hydrostatic pressure cells. During the advance of a bore hole or immediately after installation of a pressure measuring device, the hydrostatic pressure within the hole or device is seldom equal to the original pore-water pressure. A flow of water to or from the boring or pressure measuring device then takes place until pressure differences are eliminated, and the time required for practical equalization of the pressures is the time lag. Such a flow with a corresponding time lag also occurs when the pore-water pressures change after initial equalization. It is not always convenient or possible to continue the observations for the required length of time, and adequate equalization cannot always be attained when the pore-water pressures change continually during the period of observations. In such cases there may be considerable difference between the actual and observed pressures, and the latter should then be corrected for influence of the time lag.

* Consultant, Soils Division, Waterways Experiment Station.

The magnitude of the time lag depends on the type and dimensions of the pressure measuring installation, and it is inversely proportional to the permeability of the soil. A preliminary estimate of the time lag is necessary for the design or selection of the proper type of installation for given conditions. The actual time lag should be determined by field experiments so that subsequent observations may be corrected for its influence, when conditions are such that corrections are required or desirable.

Theoretical and experimental methods for determination of the time lag and its influence on the results of pressure measurements are presented in this paper. The se methods are based on the assumptions usually made in the theories on flow of fluids through homogeneous soils, and the results are subject to corresponding limitations. In addition to the time lag, ground-water observations may be influenced by several other sources of error and by irregular and changing ground-water conditions. Therefore, an initial review of ground-water conditions in general and of the principal sources of error in determination of ground-water levels and pressures is desirable in order to clarify the assumptions on which the proposed methods are based, and to delimit the field of application of these methods.

PART I: GROUND-WATER CONDITIONS AND OBSERVATIONS

Irregularities and Variations

Several sources of error in determination of ground-water levels and pressures occur primarily when irregular and/or rapidly changing ground-water conditions are encountered. Regular conditions, with the piezometric pressure level equal to the free ground-water level at any depth below the latter, are the exception rather than the rule. Irregular conditions or changes in piezometric pressure level with increasing depth may be caused by: (a) perched ground-water tables or bodies of ground water isolated by impermeable soil strata; (b) downward seepage to more permeable and/or better drained strata; (c) upward seepage from strata under artesian pressure or by evaporation and transpiration; and (d) incomplete processes of consolidation or swelling caused by changes in loads and stresses. For a more detailed description of these conditions reference is made to MEINZER (20)* and TOLMAN (30); a general discussion of ground-water observations is found in a recent report by the writer (16).

Ground-water levels and pressures are seldom constant over considerable periods of time but are subject to changes by: (a) precipitation, infiltration, evaporation, and drainage; (b) load and stress changes and/or seepage due to seasonal or diurnal variations in water levels of nearby rivers, lakes, estuaries, and the sea; (c) construction operations involving increase or decrease in surface loads and removal or displacement of soil; (d) pumping and discharge of water; (e) variations in temperature and especially freezing and thawing of the upper soil strata; and (f) variations in atmospheric pressure and humidity. The last mentioned variations may cause appreciable and rapid changes in ground-water levels, but the interrelationship between atmospheric and ground-water conditions is not yet fully explored and understood; see HUIZINGA (13), MEINZER (20), and TOLMAN (30). The possibility that minor but rapid changes in ground-water levels and pressures may occur should be realized, since such changes maybe misinterpreted and treated as errors, and since they may affect the determination of corrections for actual errors.

Sources of Error in Measurements

The principal sources of error in determination of ground-water levels and

* Numbers in parentheses refer to references at end of paper.

pressures are summarized in Fig. 1, and some further details are presented in the following paragraphs.

Hydrostatic time lag

When the water content of the soil in the vicinity of the bottom of a bore hole or intake for a pressure measuring device remains constant, and when other sources of error are negligible, the total flow or volume of water required for equalization of differences in hydrostatic pressure in the soil and in the pressure measuring device depends primarily on the permeability of the soil, type and dimensions of the device, and on the hydrostatic pressure difference. The time required for water to flow to or from the device until a desired degree of pressure equalization is attained, may be called the *hydrostatic time lag*. In order to reduce the time lag and increase the sensitivity of the installation to rapid pressure changes, the volume of flow required for pressure equalization should be reduced to a minimum, and the intake area should be as large as possible.

Stress adjustment time lag

The soil structure is often disturbed and the stress conditions are changed by advancing a bore hole, driving a well point or installing and sealing a pressure measuring device, and by a flow of water to or from the device. A permanent and/or transient change in void ratio and water content of the affected soil mass will then take place, and the time required for the corresponding volume of water to flow to or from the soil maybe called the *stress adjustment time lag*. The apparent stress adjustment time lag will be increased greatly by the presence of air or gas bubbles in the pressure measuring system or in the soil; see Items 6 to 8, Fig. 1. This time lag and its influence on the results of observations are discussed in greater detail in Part II, pages 21-29.

General instrument errors

Several sources of error may be found in the design, construction, and method of operation of the pressure measuring installation. Among such sources of error may be mentioned: (a) inaccurate determination of the depth to the water surface in wells and piezometers; (b) faulty calibration of pressure gages and cells; (c) leakage through joints in pipes and pressure gage connections; (d) evaporation of water or condensation of water vapors; (e) poor electrical connections and damage to or deterioration of the insulation; (f) insufficient insulation against extreme temperature variations or differences, especially inactivation or damage by frost. The effect of leakage through joints and connections is similar to that of seepage along the outside of conduits, discussed below.

Seepage along conduits

Seepage along the casing, piezometer tubing, or other conduits may take

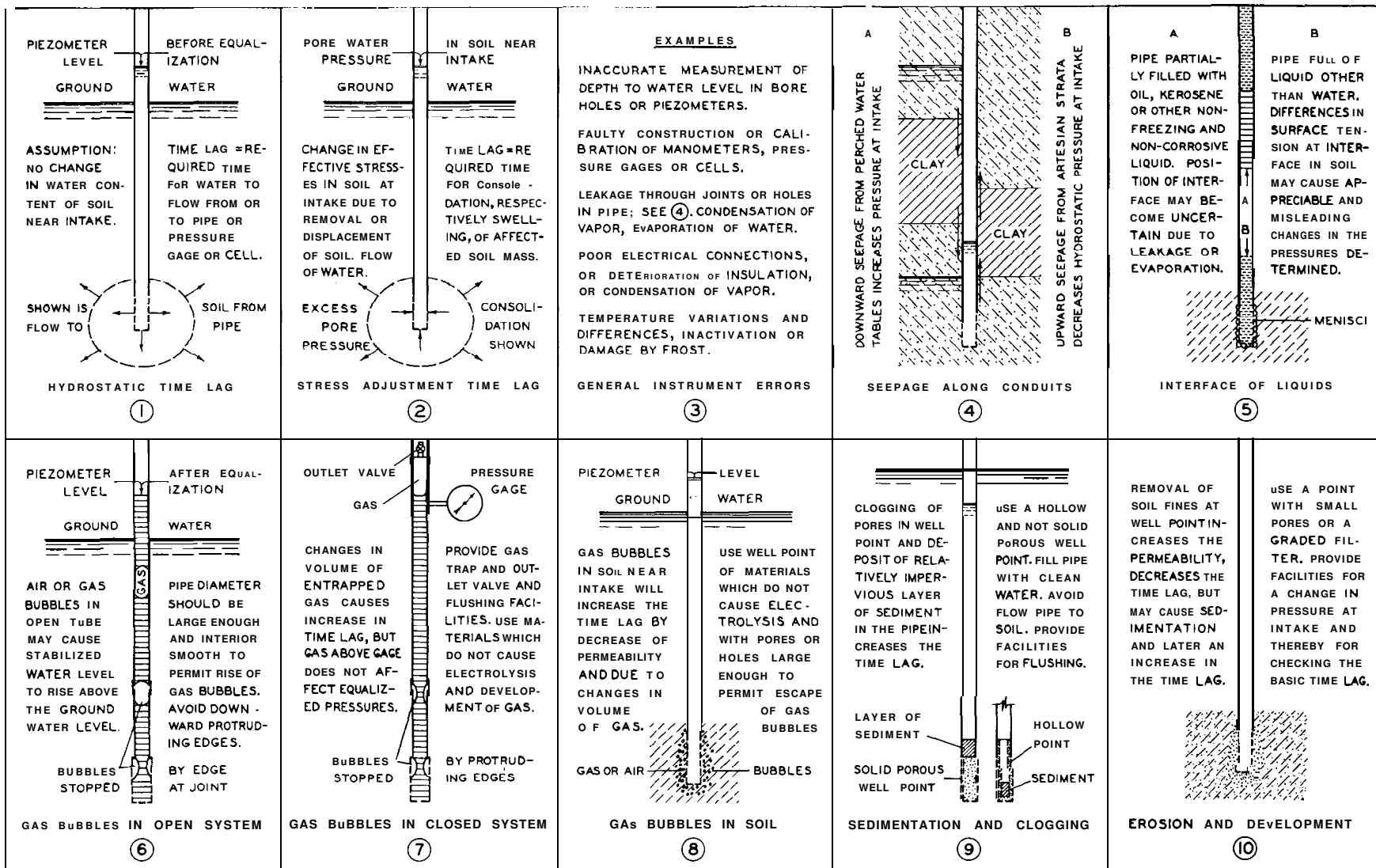

Fig. 1. Sources of error in determination of ground-water pressures

place, especially when irregular ground-water conditions are encountered. As shown in the figure, such seepage may increase or decrease the pore-water pressure in the soil at the bottom of the hole or at the intake for a pressure measuring device. Even under regular ground-water conditions seepage may occur in closed systems with attached manometer or pressure gage, and it will always affect experimental determination of the time lag of the system and of the permeability of the soil. To avoid seepage, the entire piezometer or the well point is often driven into the soil; but this method causes increased disturbance of the soil, and in many cases it is also desirable to surround the well point with a graded sand filter. When the well point is installed in an oversized bore hole, the space between the standpipe and the wall of the hole must be sealed above the well point, preferably in a fairly impermeable stratum. Puddled clay, bentonite mixtures, and cement grout have been used for sealing, but it is not always easy to obtain a tight seal and at the same time avoid stress changes in the surrounding soil because of swelling of the sealing material. A seal consisting of alternate layers of sand and clay balls, compacted by means of an annular tamping tool, has been developed and used successfully by A. CASAGRANDE (2) and (3).

Interface of liquids

To avoid corrosion or inactivation and damage by frost, manometer and pressure gages and the upper part of piezometers may be filled with kerosene or other oils. The difference in specific gravity of water and the liquid used, as well as the position of the interface, must be taken into consideration in determining the pore-water pressure. However, when observations are extended over long periods of time, the position of the interface may change because of evaporation and/or leakage and be difficult to determine. If the interface is in the wall of a well point with very fine pores, or in fine-grained soil outside the well point, additional and considerable errors may be caused by the menisci formed in the pores and by the difference in surface tension of water and the liquid in the pipe and well point.

Gas bubbles in open systems

Air or gas bubbles in an open observation well or piezometer may influence the time lag and cause the stabilized level in the pipe to rise above the ground-water or the piezometric pressure level for the soil. Therefore, the interior of the pipe should be smooth, downward protruding edges or joints should be avoided, and the diameter of the pipe should be large enough to cause the bubbles filling the cross section to rise to the surface. These requirements are fulfilled by use of seamless and jointless plastic tubing, CASAGRANDE (2) and (3), and when the inside diameter of such tubing is $\frac{3}{8}$ in. or more.

Gas bubbles in closed systems

Air or gas bubbles in a closed pipe connected to a manometer or pressure

gage will increase the time lag, but gas above the connection to the pressure gage, and small gas bubbles adhering to the walls of the pipe, will not affect the stabilized pressure indicated by the gage. Gas bubbles below the gage connection and filling the entire cross section of the pipe will influence the indicated stabilized pressure. The pipe should be provided with an air trap and outlet valve at top, and should be smooth, without protruding joints, and of a diameter large enough to permit free rise of gas bubbles. At least, facilities for occasional flushing should be provided and the entire installation should be composed of materials which do not cause development of gases through electrolysis.

Gas entrapped in the water-filled space below the diaphragm of a hydrostatic pressure cell of the type shown in Case 9, Fig. 13 -- or in the perforated cover plate or porous stone -- will not influence the ultimate pressure indicated but will greatly increase the time lag of the pressure cell. It is conceivable that a material accumulation of gas below the diaphragm may cause the time lag of a hydrostatic pressure cell to be considerably greater than that of a closed piezometer with attached manometer or Bourdon pressure gage.

Gas bubbles in soil

Air and other gases are often entrapped in the pores of the soil, even below the ground-water level, or dissolved in the water. When the gas bubbles migrate to and cluster around the well point or are released there from solution in the water, the time lag will be increased on account of volume changes of the gas and because the gas bubbles decrease the permeability of the soil. The well point should consist of materials which do not cause development of gases through electrolysis. It is also advisable to avoid an excessive decrease of the hydrostatic pressure inside the well point and a consequent decrease of the pore-water pressure in the surrounding soil, since a decrease in hydrostatic pressure may cause release of gases dissolved in the water.

Sedimentation and clogging

Sediment in the water of the standpipe or piezometer will ultimately settle at the bottom of the pipe. When a solid porous well point is used, the sediment may form a relatively impervious layer on its top and thereby increase the time lag. Therefore, a hollow well point should be used, the pipe should be filled with clean water, and facilities for occasional cleaning and flushing are desirable. An outward flow of water from the pipe and well point may carry sediment in the pipe into the pores of the walls of the point or of the surrounding soil and may thereby cause clogging and a further increase in time lag. Therefore and insofar as possible, a strong outward flow of water from well point should be avoided.

Erosion and development

A strong inward flow of water may carry fine particles from the soil into the

pipe, thereby increasing the permeability of the soil in the vicinity of the well point and decreasing the time lag of the installation. An initial strong inward flow of water and "development" of the well point may in some cases be desirable in order to decrease the time lag, provided the well point and pipe thereafter are cleaned out and filled with clean water. Uncontrolled erosion or development is undesirable on account of consequent unknown changes in the time lag characteristics of the installation, and because the soil grains may cause clogging of the well point, or the soil grains may be carried into the pipe, settle at the bottom, and ultimately increase the time lag. The porosity of, or openings in, the well point should be selected in accordance with the composition and character of the soil, or the well point should be surrounded with a properly graded sand or gravel filter.

Summary comments

It should be noted that several of the above mentioned sources of error require conflicting remedial measures, and for each installation it must be determined which one of these sources of error is most serious. Those listed under Items 3, 4, 5, and 6 in Fig. 1 will affect the results of the observations, even when these are made after practical equalization of the inside and outside pressures is attained. Those described under Items 7, 8, 9, and 10 primarily influence the time lag, but they may also affect the final results when the direct field observations are corrected for influence of the time lag. It is possible that these sources of error may develop or may disappear and that their influence on the observations may vary within wide limits during the life of a particular installation. Therefore, it is desirable that facilities be provided for controlled changes of the hydrostatic pressure inside the well point, so that the time lag characteristics may be verified or determined by methods to be described in the following sections of the paper.

The time lag characteristics of a hydrostatic pressure cell may be determined by laboratory experiments, but it should be realized that these characteristics may be radically altered and the time lag greatly increased by an accumulation of gases below the diaphragm after the pressure cell has been installed. When a hydrostatic pressure cell is to be left in the ground for prolonged periods, it would be desirable but also very difficult to provide means for releasing such gas accumulations and for verifying the basic time lag of the pressure cell in place.

PART II: THEORY OF TIME LAG

The Basic Hydrostatic Time Lag

In this and the following sections concerning the hydrostatic time lag, it is assumed that this time lag is the only source of error or that the influence of the stress adjustment time lag and other sources of error, summarized in Fig. 1, is negligible. Derivation of the basic differential equation for determination of the hydrostatic time lag, Fig. 2, is similar to that of the equations for a falling-head permeameter and is based on the assumption that Darcy's Law is valid and that water and soil are incompressible. It is also assumed that artesian conditions prevail or that the flow required for pressure equalization does not cause any perceptible draw-down of the ground-water level. The active head, H , at the time t is $H = z - y$, where z may be a constant or a function of t . The corresponding flow, q , may then be expressed by the following simplified equation,

$$q = F k H = F k (z - y) \quad (1)$$

where F is a factor which depends on the shape and dimensions of the intake or well point and k is the coefficient of permeability. This equation is valid also for conditions of anisotropic permeability provided modified or equivalent values \bar{F} and \bar{k} are used; see pages 32-35. It is assumed that the friction losses in the pipe are negligible for the small rates of flow occurring during pressure observations. Considering the volume of flow during the time dt , the following equation is obtained,

$$q dt = A dy$$

where A is the cross-sectional area of the standpipe or an equivalent area expressing the relationship between volume and pressure changes in a pressure gage or cell. By introducing q from equation (1), the differential equation can be written as,

$$\frac{dy}{z - y} = \frac{F k}{A} dt \quad (2)$$

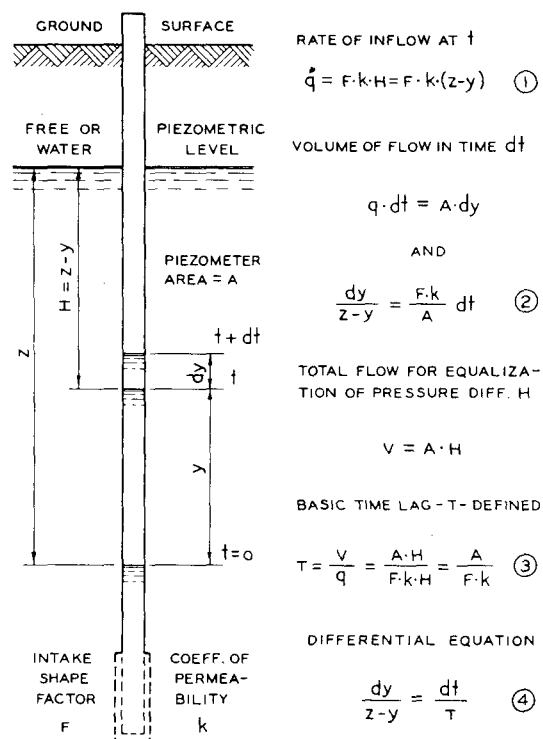

Fig. 2. Basic definitions and equations

The total volume of flow required for equalization of the pressure difference, H , is $V = A H$. The *basic time lag*, T , is now defined as the time required for equalization of this pressure difference when the original rate of flow, $q = F k H$, is maintained; that is,

$$T = \frac{V}{q} = \frac{A H}{F k H} = \frac{A}{F k} \quad (3)$$

and equation (2) can then be written,

$$\frac{dy}{z - y} = \frac{dt}{T} \quad (4)$$

This is the basic differential equation for determination of the hydrostatic time lag and its influence. Solutions of this equation for both constant and variable ground-water pressures are derived in the following sections, and methods for determination of the basic time lag by field observations are discussed. Examples of theoretical shape factors, F , and preliminary estimates of the basic time lag by means of equation (3) are presented in Part III, pages 30-37.

Applications for Constant Ground-Water Pressure

When the ground-water level or piezometric pressure is constant and $z = H_0$, Fig. 3, equation (4) becomes

$$\frac{dy}{H_0 - y} = \frac{dt}{T}$$

and with $y = 0$ for $t = 0$, the solution is,

$$\frac{t}{T} = \ln \frac{H_0}{H_0 - y} = \ln \frac{H_0}{H} \quad (5)$$

The ratio t/T may be called the time lag ratio. The head ratio, H/H_0 , is determined by the equation

$$\frac{H}{H_0} = e^{-\frac{t}{T}} \quad (6)$$

and the equalization ratio, E , by

$$E = \frac{y}{H_0} = 1 - \frac{H}{H_0} = 1 - e^{-\frac{t}{T}} \quad (7)$$

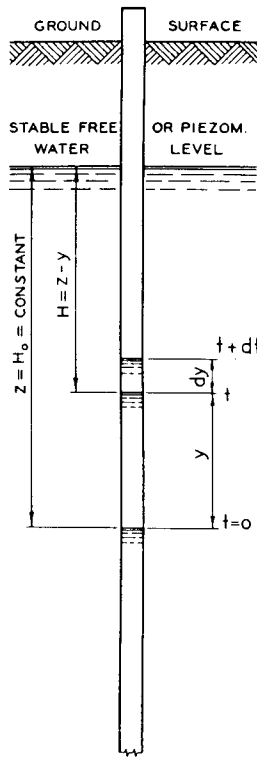

FOR CONSTANT OUTSIDE PRESS

$$z = H_0 = \text{CONSTANT}$$

DIFFERENTIAL EQUATION

$$\frac{dy}{H-y} = \frac{dt}{T}$$

T = BASIC TIME LAG

TIME LAG RATIO

$$\frac{t}{T} = \ln \frac{H_0}{H_0 - y} = \ln \frac{H_0}{H} \quad (5)$$

HEAD RATIO

$$\frac{H}{H_0} = e^{-\frac{t}{T}} \quad (6)$$

EQUALIZATION RATIO

$$E = \frac{y}{H_0} = 1 - \frac{H}{H_0} = 1 - e^{-\frac{t}{T}} \quad (7)$$

A - GENERAL CASE

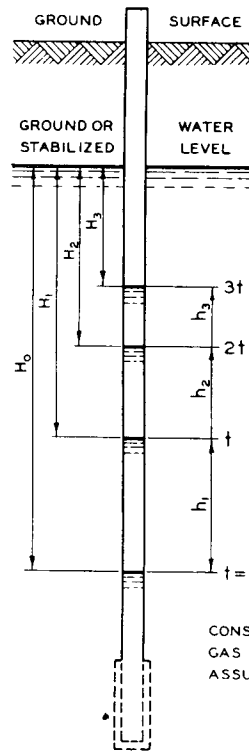

WITH THE RISE OR FALL OBSERVED AT EQUAL TIME INTERVALS, t , AND EQ. 5

$$\frac{t}{T} = \ln \frac{H_0}{H_1} = \ln \frac{H_1}{H_2} = \ln \frac{H_2}{H_3}$$

AND HENCE

$$\frac{H_0}{H_1} = \frac{H_1}{H_2} = \frac{H_0 - H_1}{H_1 - H_2} = \frac{h_1}{h_2}$$

THE BASIC TIME LAG CAN THEN BE DETERMINED BY

$$\frac{t}{T} = \ln \frac{h_1}{h_2} = \ln \frac{h_2}{h_3}, \text{ ETC.} \quad (8)$$

AND THE STABILIZED PIEZOMETRIC LEVEL BY EQ. 6 OR FIG. -3C OR BY

$$H_0 = \frac{h_1^2}{h_1 - h_2} \quad (9)$$

$$H_1 = \frac{h_2^2}{h_2 - h_3}$$

CONSTANT INTAKE SHAPE FACTOR, NO GAS IN SOIL OR WELL POINT, ETC. ASSUMED. GENERAL REQUIREMENT:

$$\frac{h_1}{h_2} = \frac{h_2}{h_3} = \frac{h_3}{h_4} \text{ ETC.}$$

B - OBSERVATIONS AT EQUAL TIME INTERVALS

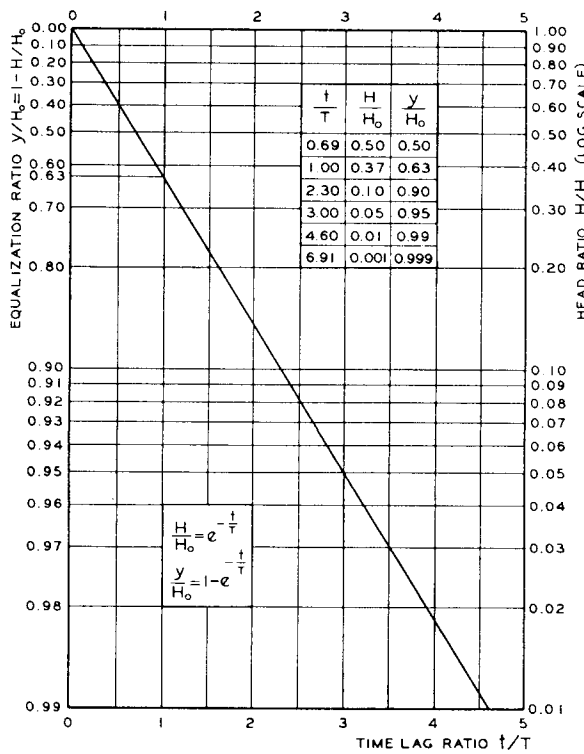

C - HEAD AND EQUALIZATION RATIOS

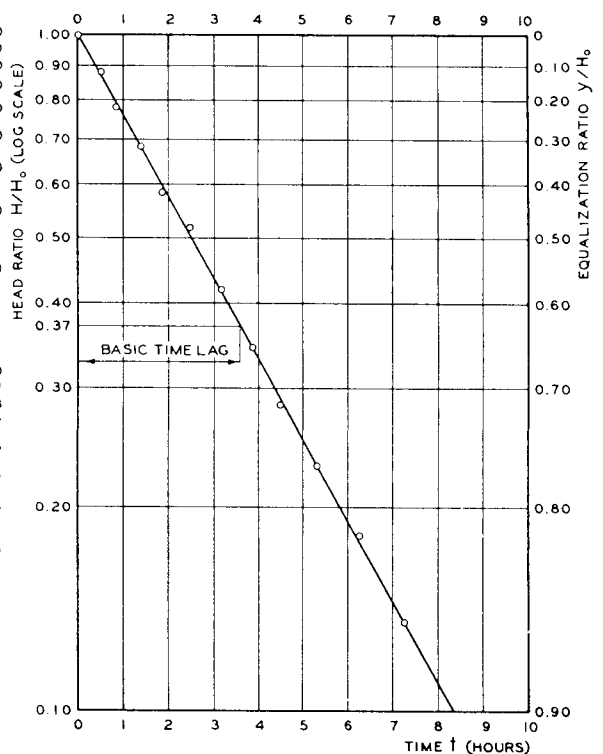

D - DETERMINATION OF BASIC TIME LAG

Fig. 3. Constant ground-water levels and pressures

A diagram representing equations (6) and (7) is shown in Fig. 3-C. It should be noted that the basic time lag corresponds to an equalization ratio of 0.63 and a head ratio of 0.37. An equalization ratio of 0.90 may be considered adequate for many practical purposes and corresponds to a time lag equal to 2.3 times the basic time lag. An equalization ratio of 0.99 requires twice as long time as 90 per cent equalization.

When the stabilized pressure level, or initial pressure difference, is not known, it may be determined in advance of full stabilization by observing successive changes in piezometer level, h_1, h_2, h_3 , etc., for equal time intervals; see Fig. 3-B. The time lag ratio is then equal for all intervals, or according to equation (5),

$$\frac{t}{T} = \ln \frac{H_0}{H_1} = \ln \frac{H_1}{H_2} = \ln \frac{H_2}{H_3}, \text{ etc.}$$

and hence,

$$\frac{H_0}{H_1} = \frac{H_1}{H_2} = \frac{H_0 - H_1}{H_1 - H_2} = \frac{h_1}{h_2}$$

or,

$$\frac{t}{T} = \ln \frac{h_1}{h_2} = \ln \frac{h_2}{h_3}, \text{ etc.} \quad (8)$$

and since $H_1 = H_0 - h_1, H_2 = H_1 - h_2$, etc.,

$$H_0 = \frac{h_1^2}{h_1 - h_2} \quad \text{or} \quad H_1 = \frac{h_2^2}{h_2 - h_3}, \text{ etc.} \quad (9)$$

It is emphasized that these equations can be used only when the influence of the stress adjustment time lag, air or gas in soil or piezometer system, clogging of the intake, etc., is negligible, or when

$$\frac{h_1}{h_2} = \frac{h_2}{h_3} = \frac{h_3}{h_4}, \text{ etc.}$$

Equations (9) form a convenient means of estimating the stabilized pressure level. In actual practice it is advisable to fill or empty the piezometer to the computed level and to continue the observations for a period sufficient to verify or determine the actual stabilized level.

When the head or equalization ratios, or the ratios between successive pressure changes for equal time intervals, have been determined, the basic time lag may be found by means of equations (5), (7), or (8). However, due to observational errors, there may be considerable scattering in results, especially when the pressure

changes are small. In general, it is advisable to prepare an equalization diagram or a semi-logarithmic plot of head ratios and time, as shown in Fig. 3-D. When the assumptions on which the theory is based are fulfilled, the plotted points should lie on a straight line through the origin of the diagram. The basic time lag is then determined as the time corresponding to a head ratio of 0.37. Examples of both straight and curved diagrams of the above mentioned type are discussed in Part III, pages 38-43.

Applications for Linearly Changing Pressures

When the ground-water or piezometric pressure level, as shown in Fig. 4, is rising at a uniform rate, $+\alpha$, or falling at the rate $-\alpha$, then

$$z = H_0 + \alpha t \quad (10)$$

and equation (4) may be written,

$$\frac{dy}{H_0 + \alpha t - y} = \frac{dt}{T} \quad (11)$$

With $y = 0$ for $t = 0$, the solution of equation (11) is,

$$\frac{y - \alpha t}{H_0 - \alpha T} = 1 - e^{-\frac{t}{T}} \quad (12)$$

which corresponds to equation (7) for constant ground-water pressure. Theoretically α , T , and H_0 may be determined, as shown in Fig. 4-B, by observing three successive changes in piezometer level at equal time intervals, t , and expressing the results by three equations similar to equation (12). By successively eliminating $(H_0 - \alpha T)$ and $e^{-\frac{t}{T}}$ from these equations, the following solutions are obtained,

$$\alpha t = \frac{h_1 h_3 - h_2^2}{h_1 + h_3 - 2h_2} \quad (13)$$

$$\frac{t}{T} = \ln \frac{h_1 - \alpha t}{h_2 - \alpha t} \quad (14)$$

$$H_0 = \alpha T + \frac{(h_1 - \alpha t)^2}{h_1 - h_2} \quad (15)$$

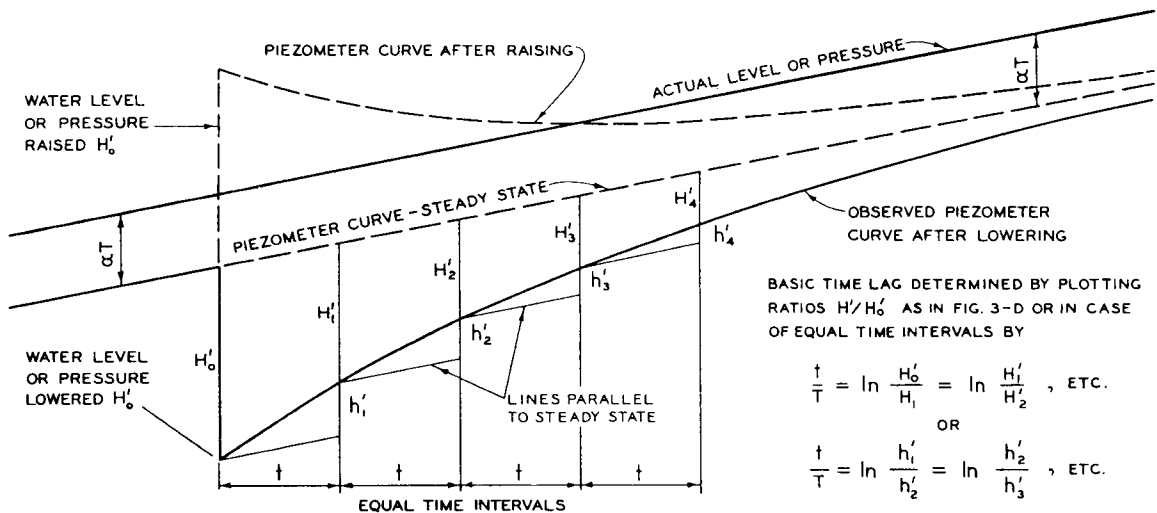
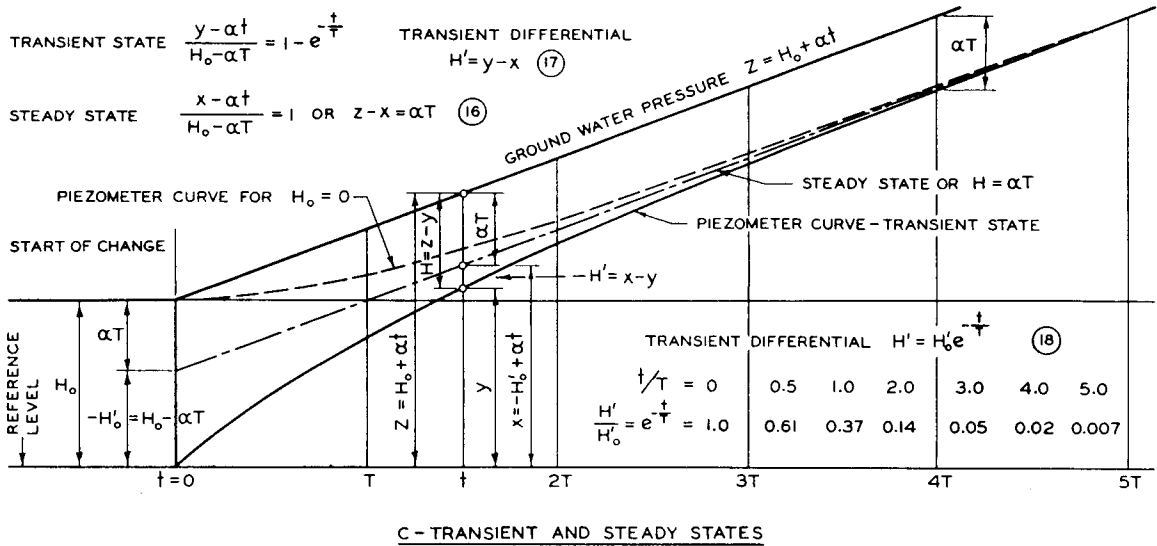
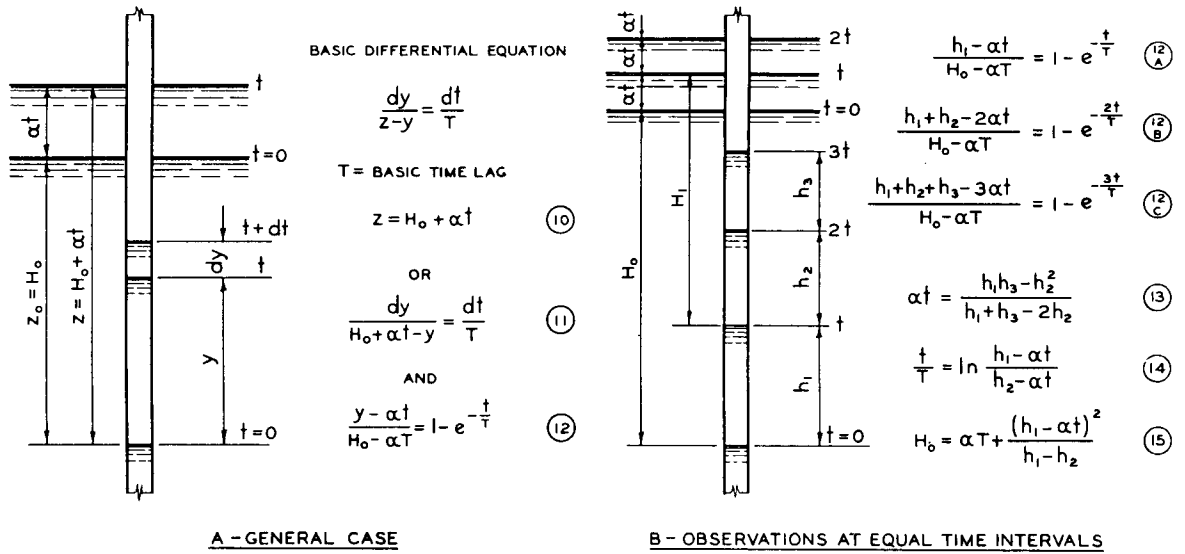

Fig. 4. Linearly changing ground-water pressures

These equations correspond to equations (8) and (9) for constant ground-water pressure. However, the form of equation (13) is such that a small error in determination of the increment pressure changes may cause a very large error in the computed value of αt . In general, it is better to determine the basic time lag and the actual ground-water pressures after the steady state, discussed below, is attained.

Referring to Fig. 4-C, equation (12) represents the transient state of the piezometer curve. With increasing values of t , the right side of this equation approaches unity and the curve the steady state. Designating the ordinates of the steady state of the piezometer curve by x , this curve is represented by,

$$\frac{x - \alpha t}{H_0 - \alpha T} = 1$$

or by means of equation (10),

$$z - x = \alpha T = \text{constant} \quad (16)$$

That is, the difference between the actual ground-water pressure and that indicated by the piezometer is constant and equal to αT during the steady state. The difference between the pressures corresponding to the transient and steady states of the piezometer curve

$$H' = y - x \quad (17)$$

may be called the transient pressure differential. For the conditions shown in Fig. 4-C, this differential is negative. With

$$x = H_0 - \alpha T + \alpha t \quad \text{and} \quad H'_0 = \alpha T - H_0$$

equation (17) can be written,

$$H' = (y - \alpha t) + H'_0$$

and by means of equation (12)

$$H' = H'_0 e^{-\frac{t}{T}} \quad (18)$$

This equation is identical with equation (6) for constant ground-water pressure; that is, the transient pressure differential can be determined as if the line representing the steady state were a constant piezometric pressure level. As will be seen in Fig. 4-C and also the diagram in Fig. 3-C, the steady state may for practical purposes be considered attained at a time after a change in piezometer level, or start of a change in the rate α , equal to three to four times the basic time lag.

When the piezometer level increases or decreases linearly with time, it may be concluded that the steady state is attained and that the rate of change, α , is equal to that for the ground-water pressure. If the piezometer level now is raised or lowered by the amount H'_0 , and the transient pressure differentials are observed, then the basic time lag may be determined by means of a semi-logarithmic plot of

the ratios H'/H'_0 and the time, t , as in Fig. 3-D; that is, the basic time lag is the time corresponding to $H'/H'_0 = 0.37$. To complete the analogy with constant ground-water pressures, the transient pressure differential may be observed at equal time intervals, t , and the basic time lag determined by,

$$\frac{t}{T} = \ln \frac{H'_0}{H'_1} = \ln \frac{H'_1}{H'_2}, \text{ etc.}$$

or by

$$\frac{t}{T} = \ln \frac{h'_1}{h'_2} = \ln \frac{h'_2}{h'_3}, \text{ etc.}$$

where h'_1, h'_2, h'_3 are the increment pressure differentials. However, it is generally advisable to use the ratios H'/H'_0 and a diagram of the type shown in Fig. 3-D. Having thus determined the basic time lag, the difference between the piezometer and ground-water levels, αT , can be computed.

Applications for Sinusoidal Fluctuating Pressures

Periodic fluctuations of the ground-water pressure, in form approaching a sinusoidal wave, may be produced by tidal variations of the water level of nearby open waters, Fig. 5-A. Such fluctuations of the ground-water pressure may be represented by the equation

$$z = z_a \sin \frac{2\pi t}{T_w} \quad (19)$$

where z_a is the amplitude and T_w the period of the wave. By means of the basic differential equation (4) the following equation for the fluctuations of the piezometer level is obtained,

$$\frac{dy}{dt} = \frac{1}{T} (z_a \sin \frac{2\pi t}{T_w} - y) \quad (20)$$

Through the temporary substitution of a new variable v and $y = ve^{-\frac{t}{T}}$, setting $\frac{2\pi T}{T_w} = \tan \frac{2\pi t_s}{T_w}$, and with $y = y_0$ for $t = 0$, the following solution of the equation is obtained,

$$y = z_a \cos \frac{2\pi t_s}{T_w} \sin \frac{2\pi}{T_w} (t - t_s) + \left[y_0 + z_a \cos \frac{2\pi t_s}{T_w} \sin \frac{2\pi t_s}{T_w} \right] e^{-\frac{t}{T}}$$

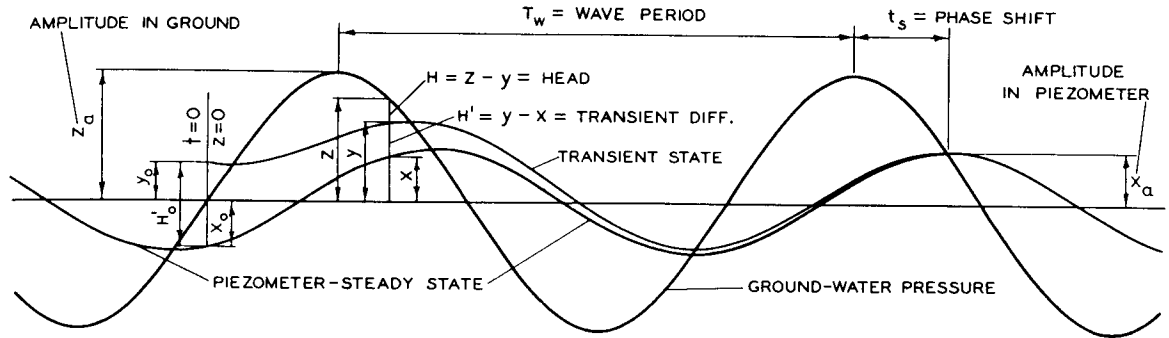

GROUND-WATER PRESSURES
 $T_w = \text{PERIOD}$ $Z_a = \text{AMPLITUDE}$

$$z = Z_a \sin \frac{2\pi}{T_w} t \quad (19)$$

PRESSURES INDICATED BY PIEZOMETER

$T = \text{BASIC TIME LAG}$

$$\frac{dy}{dt} = \frac{1}{T} (z_a \sin \frac{2\pi t}{T_w} - y) \quad (20)$$

STEADY STATE
 $t_s = \text{PHASE SHIFT}$ $x_a = \text{AMPLITUDE}$

$$x = x_a \sin \frac{2\pi}{T_w} (t - t_s) \quad (23)$$

$$\tan \frac{2\pi}{T_w} t_s = \frac{2\pi}{T_w} T \quad (21) \quad \frac{x_a}{Z_a} = \cos \frac{2\pi}{T_w} t_s \quad (22)$$

TRANSIENT STATE

$$y = x_a \sin \frac{2\pi}{T_w} (t - t_s) + (y_0 + x_a \sin \frac{2\pi}{T_w} t_s) e^{-\frac{t}{T}} \quad (24)$$

TRANSIENT DIFFERENTIAL $H' = y - x$

$$H' = (y_0 + x_a \sin \frac{2\pi}{T_w} t_s) e^{-\frac{t}{T}} = H'_0 e^{-\frac{t}{T}} \quad (25)$$

A - TRANSIENT AND STEADY STATES

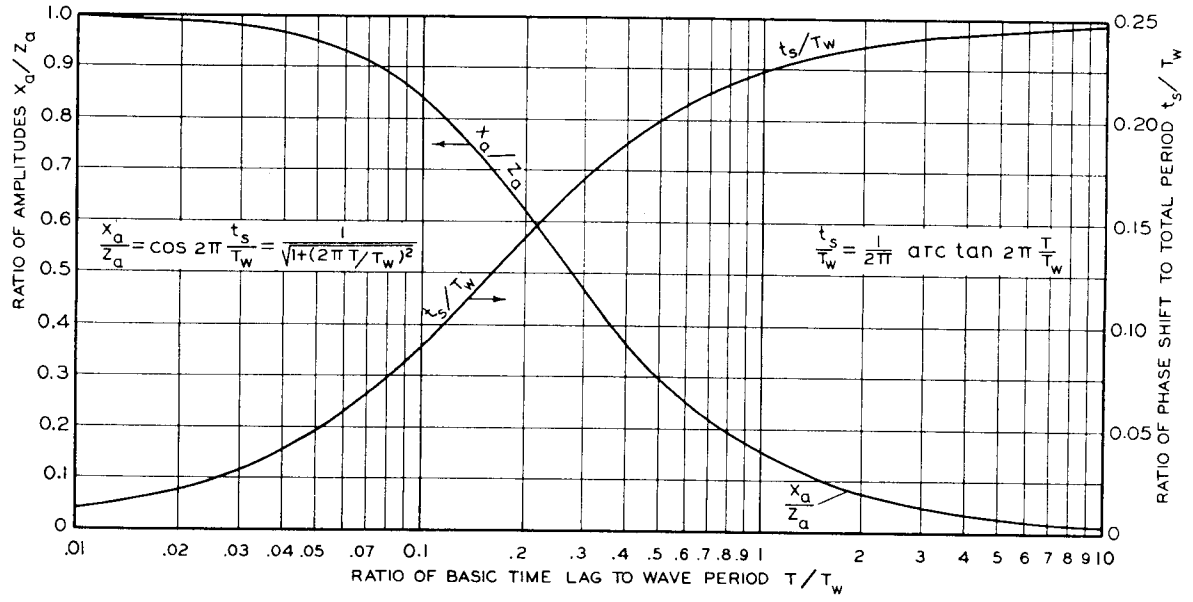

B - CHANGE IN AMPLITUDE AND PHASE OF STEADY STATE WITH BASIC TIME LAG

Fig. 5. Sinusoidal fluctuating ground-water pressure

For large values of t , $e^{-\frac{t}{T}}$ becomes very small and is zero for the steady state, for which the following equation applies, substituting x for y ,

$$x = z_a \cos \frac{2\pi t_s}{T_w} \sin \frac{2\pi}{T_w} (t - t_s)$$

This equation represents a sinusoidal wave with the phase shift t_s , determined by,

$$\tan \frac{2\pi t_s}{T_w} = \frac{2\pi T}{T_w} \quad (21)$$

and the amplitude

$$x_a = z_a \cos \frac{2\pi t_s}{T_w} = \frac{z_a}{\sqrt{1 + (2\pi T/T_w)^2}} \quad (22)$$

The equation for the steady state can then be written,

$$x = x_a \sin \frac{2\pi}{T_w} (t - t_s) \quad (23)$$

and the equation for the transient state,

$$y = x_a \sin \frac{2\pi}{T_w} (t - t_s) + (y_0 + x_a \sin \frac{2\pi t_s}{T_w}) e^{-\frac{t}{T}} \quad (24)$$

The transient pressure differential, $H' = y - x$, is determined by

$$H' = (y_0 + x_a \sin \frac{2\pi t_s}{T_w}) e^{-\frac{t}{T}} = H'_0 e^{-\frac{t}{T}} \quad (25)$$

where H'_0 is the transient differential for $t = 0$. Equation (25) is identical with equations (6) and (18), and the transient pressure differential can also in this case be computed as if the steady state were a constant pressure level. H' may be determined as a function of H'_0 by means of the diagram shown in Fig. 3-C, and it will be seen that for practical purposes the steady state is reached after elapse of a time equal to three to four times the basic time lag.

Equations (22) and (23) are represented by the diagram in Fig. 5-B, by means of which the phase shift and the decrease of amplitude in the piezometer can easily be determined. If the fluctuations of the piezometer level have reached the steady state and the wave period, T_w , and the phase shift, t_s , can be observed in the field, it is theoretically possible to determine the basic time lag by means of the

diagram in Fig. 5-B. However, it is difficult to determine the phase shift by direct observation, since it cannot be assumed that the pressure fluctuations in the ground water are in phase with those of the surface waters. When the fluctuations in the ground-water pressure are caused by load and stress changes without material seepage and volume changes of the soil, it is possible that the phase shift in pore-water pressures, with respect to the surface water, may be insignificant even though a material decrease in amplitude occurs. On the other hand, when pressure changes in the pore water in part are caused by infiltration or are accompanied by changes in water content of the soil, then it is possible that there also will be a material shift in phase of the pressure fluctuations. The basic time lag may be determined during the steady state by raising or lowering the piezometer pressure, observing the transient pressure differentials, and plotting the ratios H'/H'_0 and the elapsed time in a diagram similar to that shown in Fig. 3-D.

Corrections for Influence of the Hydrostatic Time Lag

The characteristics of an installation for determination of ground-water levels and pressures may change with time because of sedimentation, clogging, and accumulation of gases in the system or in the soil near the intake. When observations of such levels and pressures are to be corrected for influence of the hydrostatic time lag, the first task is to determine the basic time lag and verify that the assumptions, on which the general theory is based, are satisfied. This is best accomplished during periods when the ground-water pressure is constant, but as shown in the foregoing sections, the verification may also be performed during the steady state of linear and sinusoidal variations in the ground-water and piezometer levels.

Verification by means of transient pressure differentials can be used irrespective of the form of the curve representing the steady state of pressure variations. The pressure variations may be represented by the following general equations, $z = F(t)$ for the ground-water pressure; $x = f(t)$ for the steady state of the piezometer pressure; and $y = g(t)$ for the transient state or after the piezometer pressure has been raised or lowered by an arbitrary amount H'_0 . The transient pressure differential is the $H' = y - x$, and according to equation (4), which applies to all conditions,

$$\frac{dy}{z - y} = \frac{dt}{T} = \frac{dx}{z - x} = \frac{dy - dx}{x - y} = \frac{dH'}{H'}$$

or

$$\ln H' = -\frac{t}{T} + C$$

and with $H' = H'_0$ for $t = 0$

$$\frac{t}{T} = \ln \frac{H'_0}{H'}$$

which is identical with equation (5). Therefore, when the piezometer pressure varies in such a manner that the pressures can be predicted with sufficient accuracy for a future period of reasonable length, the basic time lag may be determined by raising or lowering the piezometer pressure by an arbitrary amount, H'_0 , observing the transient pressure differentials, H' , and plotting the ratios H'/H'_0 as a function of time as shown in Fig. 3-D. Application of the basic equation (4) requires that the points in the semi-logarithmic plot fall on a straight line through the origin of the diagram.

Having determined the basic time lag and verified that the assumptions are satisfied, corrections for influence of the time lag in case of linear or sinusoidal variations may be determined as shown in Figs. 4 and 5. In case of irregular fluctuations, it should first be noted that when the piezometer curve passes through a maximum or minimum, the pressure indicated by the piezometer must be equal to that of the ground water. In this connection it is again emphasized that the fluctuations of the ground-water pressure are not necessarily in phase with those of the water level of nearby surface waters. The maxima or minima of the piezometer variations may be used as starting points for the corrections, which may be determined by assuming either an equivalent constant value or, alternatively, an equivalent constant rate of change of the ground-water pressure during each time interval.

The first of these methods is shown in Fig. 6-A. The difference, H_c , between the equivalent constant ground-water pressure and the piezometer pressure at the start of the time interval may be determined by equation (7) and substituting H_c for H_0 and h for y ; that is,

$$H_c = \frac{h}{E} \quad (26)$$

where h is the change in piezometer pressure and E is the equalization ratio for the time interval, t , or time lag ratio t/T ; see Fig. 3-C. It is now assumed that the actual ground-water pressure in the middle of the time interval is equal to the equivalent constant pressure during the interval.

In applying the second method of correction, Fig. 6-B, it is assumed that the pressure difference at the beginning of the time interval, H_0 , has been determined, for example by starting the operations at a maximum or minimum of the piezometer curve. Designating the equivalent uniform rate of change in ground-water pressure by α , the total change during the time interval, $H_t = \alpha t$, can be computed by means of equation (12), or when solving for αt and introducing the equalization ratio E ,

$$H_t = \frac{h - EH_0}{1 - E \frac{T}{t}} \quad (27)$$

This method will usually give more accurate results than the method of equivalent constant pressure, but the latter method is easier to apply. The results obtained by the two methods are compared in Fig. 6-C, and it will be seen from the equations and the diagram that the difference in results is only a few per cent when the initial pressure difference is large and the time interval is small, in which case the easier method of equivalent constant pressures may be used. On the other hand, there is considerable difference in results and the method of equivalent constant rate of change should be used when the initial pressure difference is small and the time lag ratio is large.

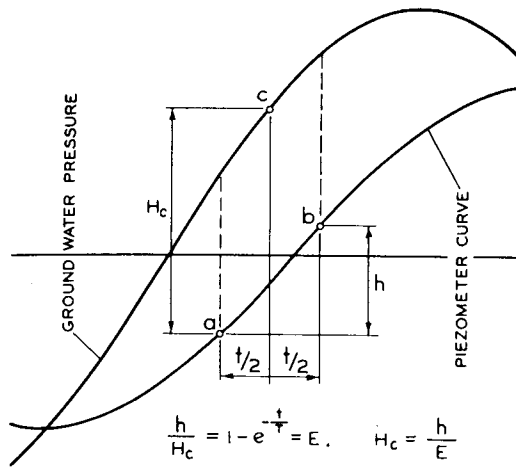

$$\frac{h}{H_c} = 1 - e^{-\frac{t}{T}} = E, \quad H_c = \frac{h}{E}$$

DETERMINATION OF GROUND-WATER PRESSURE METHOD OF EQUIVALENT CONSTANT PRESSURE

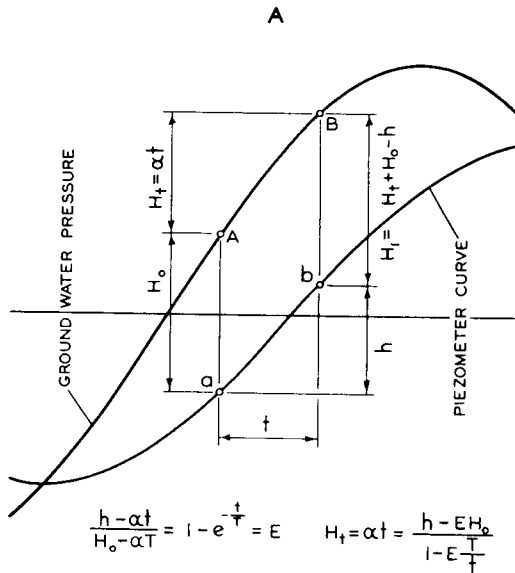

$$\frac{h - \alpha t}{H_0 - \alpha t} = 1 - e^{-\frac{t}{T}} = E \quad H_t = \alpha t = \frac{h - E H_0}{1 - E \frac{t}{T}}$$

DETERMINATION OF GROUND-WATER PRESSURE METHOD OF LINEAR CHANGE IN PRESSURE

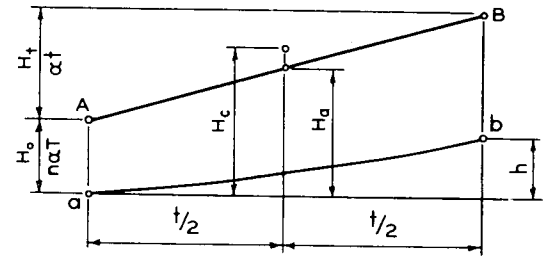

ASSUME LINEAR CHANGE A TO B AND $H_t = \alpha t, H_0 = n \alpha T$

$$\frac{h - \alpha t}{H_0 - \alpha T} = 1 - e^{-\frac{t}{T}} = E, \quad h = \alpha t + E(n-1)\alpha T, \quad n = \frac{H_0 \cdot t}{H_t \cdot T}$$

$$H_c = \frac{h}{E} = \frac{\alpha t}{E} + (n-1)\alpha T \quad H_a = H_0 + \frac{1}{2}\alpha t = n\alpha T + \frac{1}{2}\alpha t$$

$$\frac{H_c}{H_a} = \frac{n + \frac{1}{E} \frac{t}{T} - 1}{n + \frac{1}{2} \frac{t}{T}}$$

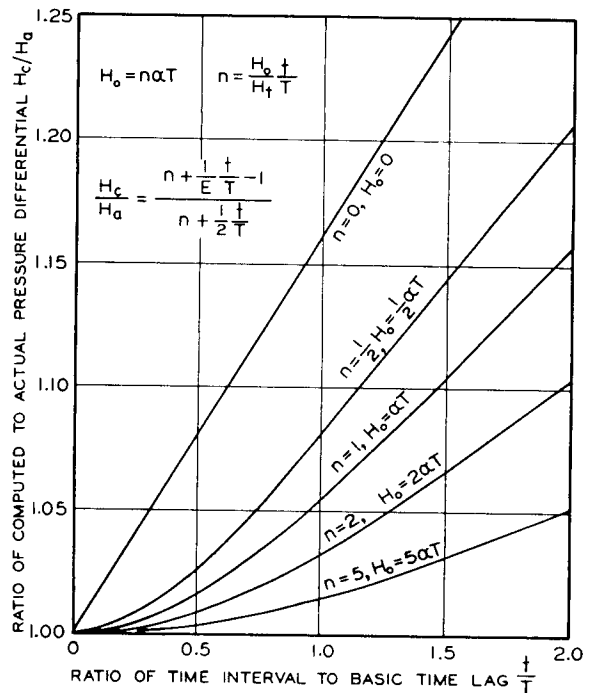

C - RELATIVE ACCURACY OF METHODS

Fig. 6. Corrections for influence of hydrostatic time lag

Influence of the Stress Adjustment Time Lag

In absence of detailed theoretical and experimental investigations of the stress adjustment time lag and its influence on pressure observations, the following discussion is tentative in character, and its principal object is to call attention to the problems encountered.

As mentioned in discussing Fig. 1, the stress adjustment time lag is the time required for changes in water content of the soil in the vicinity of the intake or well point as a result of changes in the stress conditions. A distinction must be made between the initial stress changes and adjustments, which occur only during and immediately after installation of a pressure measuring device, and the transient but repetitive changes which occur each time water flows to or from the intake or well point during subsequent pressure observations.

Initial disturbance and stress changes

When a boring is advanced by removal of soil, the stresses in the vicinity of its bottom or section below the casing will be decreased with a consequent initial decrease in pore-water pressure and tendency to swelling of the soil. A flow of water from the boring to the soil will increase the rate of swelling, and the combined initial hydrostatic and stress adjustment time lags will probably be decreased when the initial hydrostatic pressure inside the boring or well point is slightly above the normal ground-water pressure, Fig. 7-A.

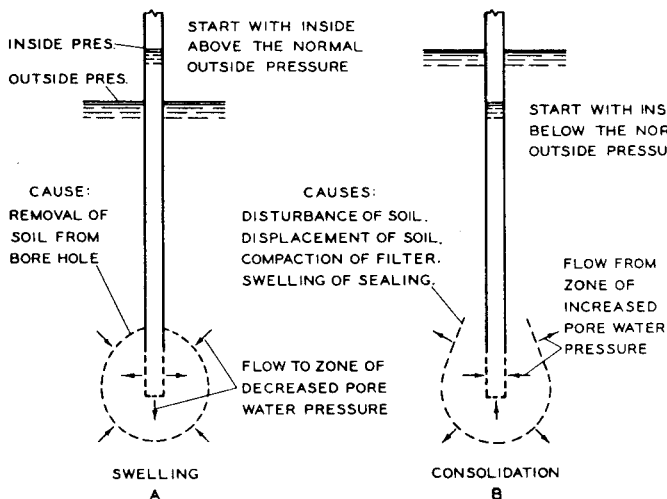

Fig. 7. Initial disturbance and stress changes

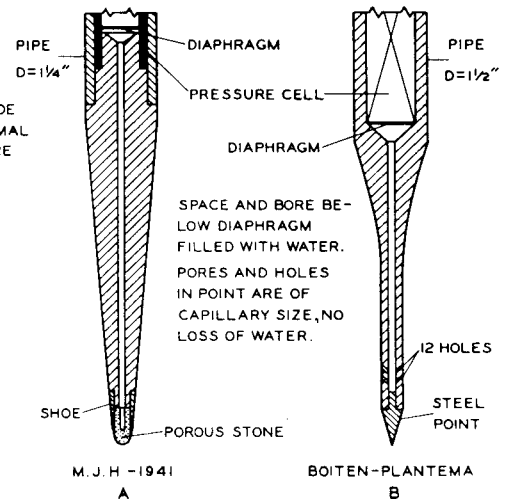

Fig. 8. Points for pressure sounding rod

A zone with increased pore-water pressures and a tendency to consolidation of the soil may be caused by disturbance and displacement of soil during the driving of a well point and by compaction of a sand filter or a seal above a well point or pressure cell installed in an oversize bore hole, Fig. 7-B. Subsequent swelling of the sealing material may also cause consolidation of the surrounding soil, but its effect on the pore-water pressures in the vicinity of the well point is uncertain. A flow of water from the soil to the well point will increase the rate of consolidation, and when the basic time lag of the installation is large, the combined initial hydrostatic and

stress adjustment time lags will probably be decreased when the initial hydrostatic pressure inside the well point is below the normal ground-water pressure.

The initial stress adjustment time lag depends on the dimensions of the zone of stress changes and on the permeability, sensitivity to disturbance, and consolidation characteristics of the soil. The initial stress adjustment time lag will be small compared to the hydrostatic time lag when the total volume change of the soil is small compared to the required increase or decrease of the volume of water in the pressure measuring device, as in case of a boring or observation well in coarse-grained soils. On the other hand, the stress adjustment time lag may be very large compared to the hydrostatic time lag for a pressure cell installed in fine-grained and highly compressible soils.

The initial stress adjustment time lag can be reduced by decreasing the dimensions of the well point and/or filter, but this will increase the hydrostatic time lag. When the ground-water observations are to be extended over a considerable period of time, the hydrostatic time lag is usually governing and the well point should be large. On the other hand, when it is desired to make only a single or a few measurements at each location and depth, and when a sensitive pressure measuring device is used, then the well point should be small in order to reduce the zone of disturbance and the initial stress adjustment time lag. Even then there is an optimum size, and when the dimensions of the well point are made smaller than that size, the consequent decrease in the initial stress adjustment time lag may be more than offset by an increase in the hydrostatic time lag.

Examples of points for pressure measuring devices, similar to sounding rods and intended for reconnaissance exploration of ground-water conditions in soft or loose soils, are shown in Fig. 8. The one to the left, designed by the writer (14, 15), has a larger intake area than the one shown to the right and designed by BOITEN and PLANTEMA (1), but the latter is sturdier and will probably cause less disturbance of the soil in the immediate vicinity of the point.

Transient consolidation or swelling of soil

When water is flowing to or from a pressure measuring device, the pore-water pressures, the effective stresses in, and the void ratio of the soil in the vicinity of the well point or intake will be subject to changes. As a consequence, the rate of flow of water to or from the intake will be increased or decreased, and this will influence the shape of the equalization diagrams. The above mentioned changes are more or less transient, and with decreasing difference between the piezometer and ground-water pressures, the stress conditions and void ratios will approach those corresponding to the pore-water pressures in the soil mass as a whole. The

probable sequence of consolidation and swelling of the soil around a rigid well point when the piezometer level is lowered or raised is shown in Fig. 9.

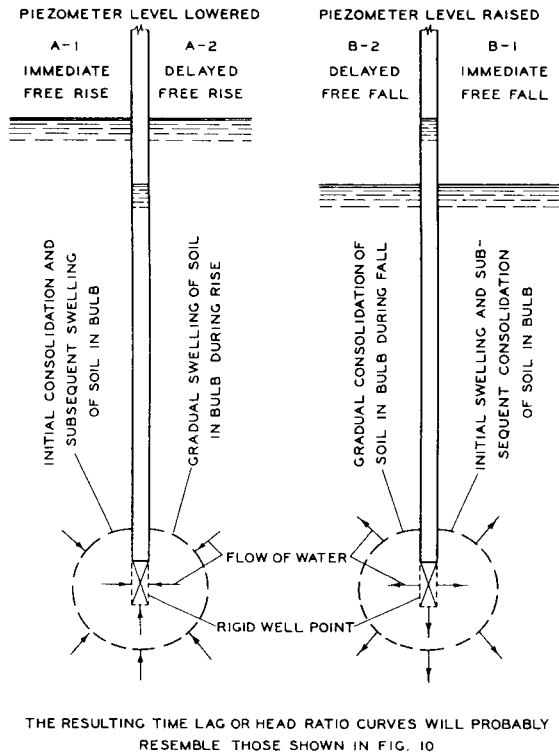

Fig. 9. Transient changes in void ratio

test results are shown in Fig. 10. The volume changes during these permeability tests were very small since the test specimens were overconsolidated in order to obtain nearly equal consolidation and swelling characteristics.

When the water level in the standpipe, Fig. 10, is raised and immediately thereafter allowed to fall -- corresponding to Case B-1 in Fig. 9 -- an initial swelling of the soil takes place, since the total vertical stresses remain constant whereas the pore-water pressure has been increased and the effective stresses tend to decrease. As a consequence, the rate of flow from the standpipe to the soil sample is increased and the initial slope of the equalization diagram becomes steeper. As the swelling progresses and the water level in the standpipe falls, the rate of excess flow decreases; the equalization diagram acquires a concave curvature, and a condition will be reached where the void ratio of the soil corresponds to the pore-water

* The relatively simple conditions shown in Fig. 9, and a comparison with the conditions in a permeameter, may not apply in case of an open bore hole, when the well point or intake is not rigid, and when the pressure in Case B is so great that the soil is deflected and a clearance is created between the well point and the soil.

It is difficult by theory or experiment to determine the changes in void ratio and water content around a well point, but similar changes occur during soil permeability tests with a rising or falling head permeameter, and observations made immediately after the head is applied in such a permeameter usually furnish too high values for the coefficient of permeability and are discarded as unreliable. Although the stress conditions around a rigid well point are more complicated than in a soil test specimen in a permeameter, the results of permeability tests, which are extended until practical equalization of the water levels is attained, will furnish an indication of the magnitude of the transient consolidation and swelling and on the resulting shape of equalization diagrams for a rigid well point*. A series of such tests were performed with Atlantic muck, a soft organic clay, and the testing arrangement and some

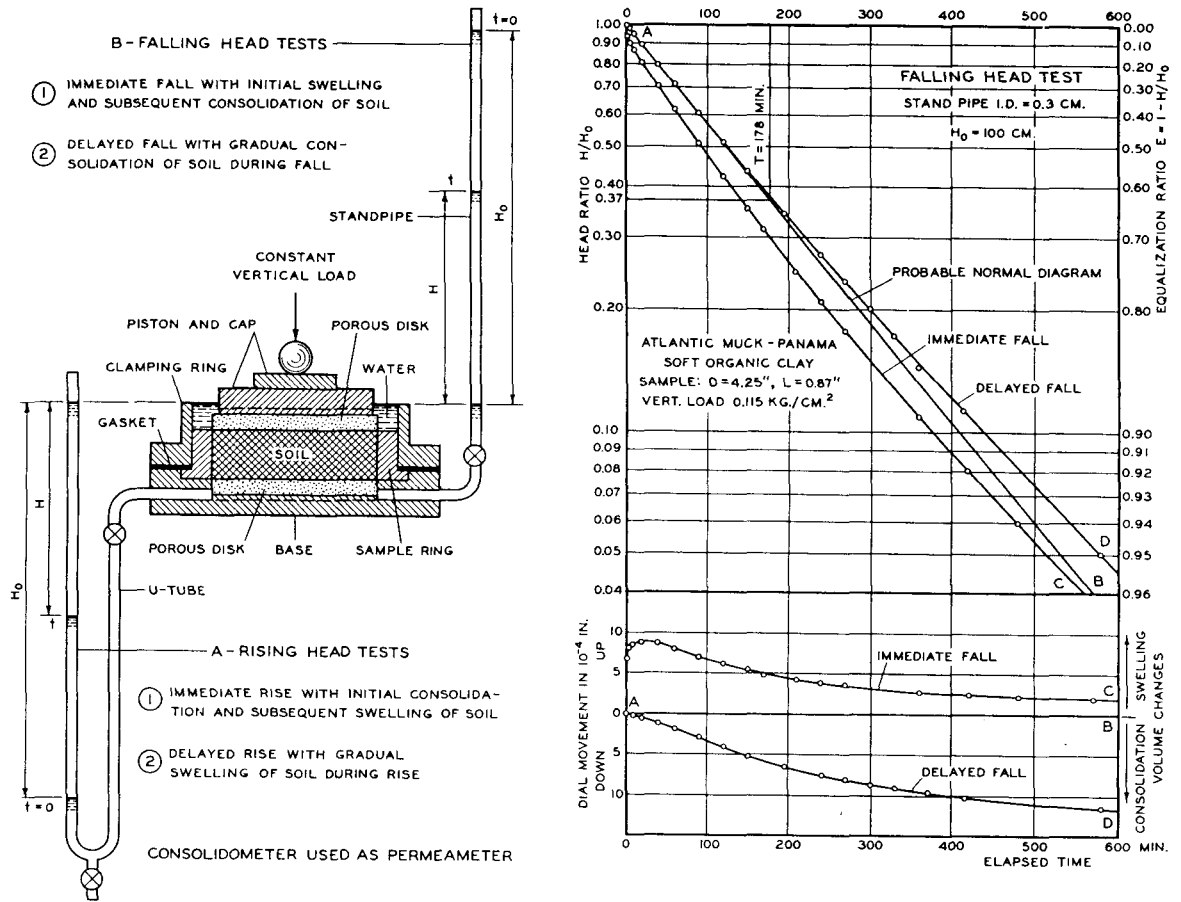

Fig. 10. Volume changes during laboratory permeability tests

pressure indicated by the standpipe level. With further fall in this level and decrease in pore-water pressures, a reconsolidation of the soil takes place with a consequent deficiency in rate of flow from the standpipe. The curvature of the equalization diagram decreases; the diagram becomes fairly straight and may even acquire a slight convex curvature as it approaches the normal diagram, obtained when there is no change in void ratio of the soil. However, the ultimate shape and slope of the diagram could not be determined from the results of tests so far performed, since these results were influenced by very small temperature changes in the laboratory.

When the water level in the standpipe is raised and maintained in its upper position until the initial swelling of the soil sample is completed and then allowed to fall -- Cases B-2 in Figs. 9 and 10 -- a gradual re-consolidation of the soil takes place during the actual test, and an equalization diagram which lies above the normal diagram is obtained, but its lower part is more or less parallel to the lower part of the diagram for immediate fall.

Similar diagrams were obtained by rising head tests. When the water level in the U-tube is lowered and immediately thereafter allowed to rise, Case A-1 in Figs. 9 and 10, the soil will be subjected to an initial consolidation with a consequent increase in rate of flow to the U-tube, but this volume decrease of the soil will later be eliminated by a swelling and a corresponding deficiency in rate of flow to the U-tube. The resulting equalization diagram has a concave curvature and lies below the normal diagram. When the water level in the U-tube is maintained in its lower position until the initial consolidation is completed and then allowed to rise, a gradual swelling of the soil takes place; the rate of flow to the U-tube is decreased, and the equalization diagram lies above the normal diagram.

All the above mentioned tests were repeated several times with both undisturbed and remolded soil, and the results obtained were all similar to those shown in Fig. 10. A slight sudden drop in head ratio in case of immediate fall -- or rise -- is probably due to a small amount of air in the system. As already indicated, the shape of the lower part of the diagrams was influenced by small amounts of leakage and evaporation and by temperature changes. The temperature in the laboratory did not vary more than 1.5° F from the mean temperature, but even such small variations are sufficient to cause conspicuous irregularities in the test results when the active head is small. However, it is believed that the results are adequate for demonstration of the consolidation and swelling of the soil during permeability tests and of the resulting general shape of the equalization diagrams.

Volume changes of gas in soil

The influence of gas bubbles in an open or closed pressure measuring system is summarized in Fig. 1 and discussed briefly on pages 6 and 7. Whereas such gas bubbles may cause a change in both the ultimate indicated pressure and the time lag or slope of the equalization diagram, they will not materially influence the shape of the latter, since changes in pressure and volume of the gas bubbles occur nearly simultaneously with the changes in hydrostatic pressure within the system. On the other hand, when the gas bubbles are in the soil surrounding the well point and their volume and the water content of the soil are changed, there will be a time lag between changes in hydrostatic pressure in the system and corresponding changes in pressure and volume of the gas bubbles, and this time lag will cause a change in both slope and shape of the equalization diagrams. The general effect of the gas bubbles is an increase in the apparent compressibility of the soil, and the equalization diagrams should be similar to those shown in Fig. 10.

The change in volume of the gas bubbles, when the piezometer level is lowered or raised, and probable resulting equalization diagrams are shown in Fig. 11. This figure and the following discussion are essentially a tentative interpretation of the results of the laboratory permeability tests and the field observations shown in Figs. 10 and 17.

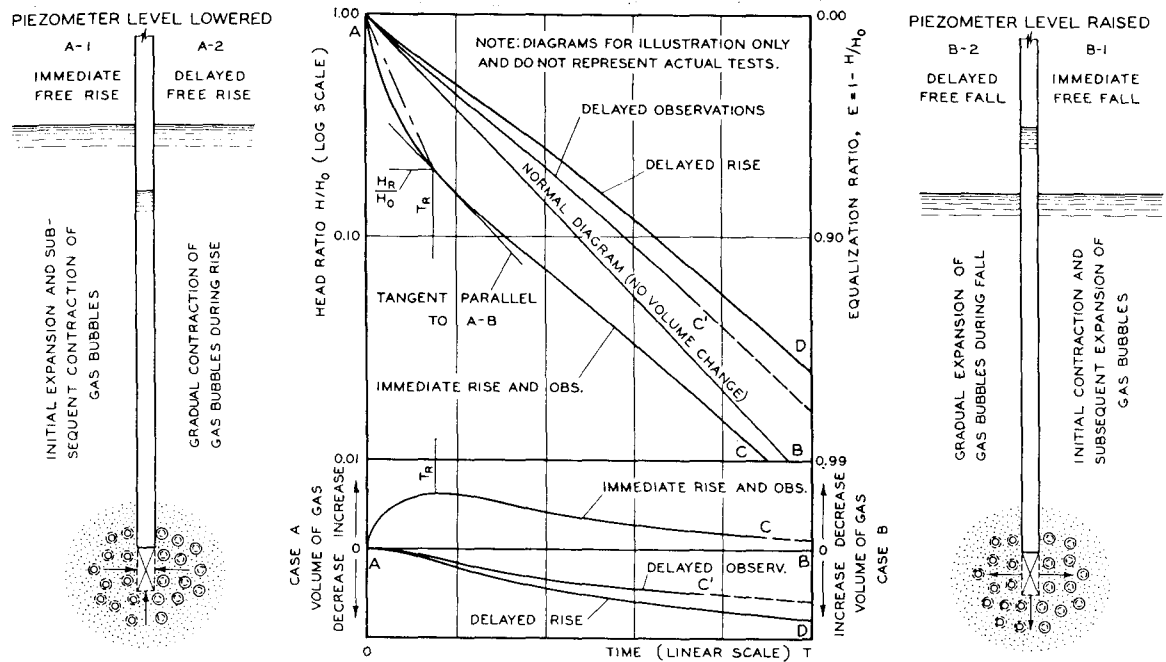

Fig. 11. Influence of volume changes of gas in soil

When the piezometer level suddenly is lowered and immediately thereafter allowed to rise, Case A-1, the pressure in the pore water is decreased, and the gas bubbles tend to expand and force an excess amount of water into the well point; that is, the initial rate of rise of the piezometer level will be increased and the equalization diagram, A-C, will have a steeper slope than the normal diagram, A-B, and a concave curvature. It is emphasized that the normal diagram, A-B, corresponds to the condition of no volume change of the gas bubbles and not to complete absence of gas bubbles in the soil. Even when the volume of the gas bubbles does not change, the presence of these bubbles will decrease the effective permeability of the soil and increase the time lag of the piezometer. As the piezometer level rises, the difference between the pressures in the gas bubbles and the surrounding pore water decreases. At the time T_r these pressures are equalized, and the rate of excess inflow ceases; that is, the tangent to the equalization diagram, A-C, at the time T_r should be parallel to the normal diagram, A-B. With a further rise in piezometer level, the pore-water pressure around the well point increases; the volume of the gas bubbles decreases, and there will be a deficiency in inflow of water. The curvature of the equalization diagram decreases and may eventually become zero or, perhaps, even change to a slight convex curvature as the volume of the gas bubbles approaches its original value.

If the observations were started at the time of reversal of the volume changes, T_r , the volume of the gas bubbles would decrease throughout the observations; there

would be a deficiency in the rate of inflow, and the equalization diagram, A-C', would be above the normal diagram. A similar but higher-lying diagram, A-D, would be obtained if the piezometer level is not allowed to rise immediately after lowering but is maintained in its lower position until the initial swelling of the gas bubbles is completed, Case A-2. The two diagrams A-C and A-D should ultimately become parallel, and the normal diagram is a straight line between these limiting diagrams and is tangent at "A" to diagrams A-C' and A-D.

When the piezometer level suddenly is raised and immediately thereafter is allowed to fall, Case B-1, the volume of the gas bubbles at first decreases with a consequent excess outflow of water from the piezometer. Later on the gas bubbles expand until their original volume is attained, and during this period there will be a corresponding deficiency in rate of outflow. The resulting equalization diagram is similar in form to A-C for Case A-1. When the piezometer level is maintained in its upper position until the initial contraction of the gas bubbles is completed and then is allowed to fall, an equalization diagram similar to A-D is obtained.

Normal operating conditions

The discussions in the foregoing sections concern mainly time lag tests during which the piezometer level suddenly is changed whereas the general ground-water level or pore-water pressure remains constant. In normal operation the ground-water pressure changes first, and the piezometer level follows these changes with a certain pressure difference or time lag. When the ground-water level or pore-water pressure changes, the void ratio of the soil and the volume of gas bubbles below the ground-water level also tend to change, but the rate of such changes generally decreases in the immediate vicinity of a well point or intake for a pressure measuring installation on account of the pressure difference and time lag. However, all changes progress in the same direction and there is no initial increase in void ratio and water content followed by a decrease -- or vice versa -- as in the case of time lag tests.

In general, normal operating conditions resemble in most cases those of delayed fall or rise, or rather delayed observations, shown in Figs. 10 and 11. *It is probable that the time lag during normal operating conditions corresponds to an equalization diagram which, for practical purposes, may be represented by a straight line through the origin of the diagram and parallel to the lower portions of the diagrams obtained in time lag tests.* However, sufficient experimental data for verification of the suggested approximation -- especially comparative tests during rapidly changing ground-water pressures and with several pressure measuring installations having widely different basic time lags -- are not yet available.

As indicated by permeability tests of the type shown in Fig. 10, it is probable that the influence of swelling or consolidation of the soil is very small or negligible when observation wells or open piezometers are used in ground-water observations,

but it is also possible that such changes in void ratio may cause appreciable distortion of the equalization diagrams and increase in actual time lag when pressure gages or cells with a small basic time lag are used and the soil is relatively compressible. On the other hand, gas bubbles in the soil around a well point may cause considerable distortion of the equalization diagrams and increase in actual time lag even for open piezometers; see Fig. 17. Accumulation of gas in the pressure measuring system causes no curvature of the equalization diagram but materially decreases its slope and increases the effective time lag under normal operating conditions.

PART III -- DATA FOR PRACTICAL DETERMINATION AND USE OF TIME LAG

Flow through Intakes and Well Points

For the purpose of designing or selecting the proper type of pressure measuring installation for specific soil and ground-water conditions, the basic time lag may be computed by means of equation (3). In order to facilitate such computations, formulas for flow through various types or shapes of intakes or well points are assembled in Fig. 12. These formulas are all derived on the assumption that the soil stratum in which the well point is placed is of infinite thickness and that artesian conditions prevail, or that the inflow or outflow is so small that it does not cause any appreciable change in the ground-water level or pressure. Except when otherwise noted by subscripts, as in k_v and k_h , it is also assumed that the permeability of the soil, k , is uniform throughout the stratum and equal in all directions.

The formula for Case 1 is that for a point source, and by reasons of symmetry the flow in Case 2 is half as great, but the formula for this case has also been derived directly by DACHLER (6). Derivation of the formula for Case 3 is given in the books by FORCHHEIMER (9) and DACHLER (6). A simple formal mathematical solution for Case 4 is not known to the writer, and the formula shown in Fig. 12 is empirical and based on experiments by HARZA (12) and a graphical solution through radial flow nets by TAYLOR (28). The formulas for Cases 5 and 6 are derived by addition of the losses in piezometric pressure head outside the casing -- Cases 3 and 4 -- and in the soil inside the casing. The formulas are only approximately correct since it is assumed that the velocity of flow is uniformly distributed over the length and cross section of the soil plug. It is taken into consideration that for soil within the casing the vertical permeability is governing and may be different from that of the soil below the casing on account of soil disturbance and sedimentation.

The formula given for Case 7 is derived by DACHLER (6) on basis of flow from a line source for which the equipotential surfaces are semi-ellipsoids. Therefore, and as emphasized by DACHLER, the formula can provide only approximate results when it is applied to a cylindrical intake or well point. In Case 8 it is assumed that the flow lines are symmetrical with respect to a horizontal plane through the center of the intake, and the formula for Case 7 is then applied to the upper and lower halves of the intake. The accuracy of these formulas probably decreases with decreasing values of L/R and L/D . When these ratios are equal to unity, Cases 7 and 8 correspond to Cases 2 and 1, respectively, but furnish 13.4 per cent greater values for the flow. For large values of L/R and L/D the following simplified formulas may be used,

$$\text{CASE 7.} \quad q = \frac{2\pi L k H}{\ln(2L/R)}$$

$$\text{CASE 8.} \quad q = \frac{2\pi L k H}{\ln(2L/D)}$$

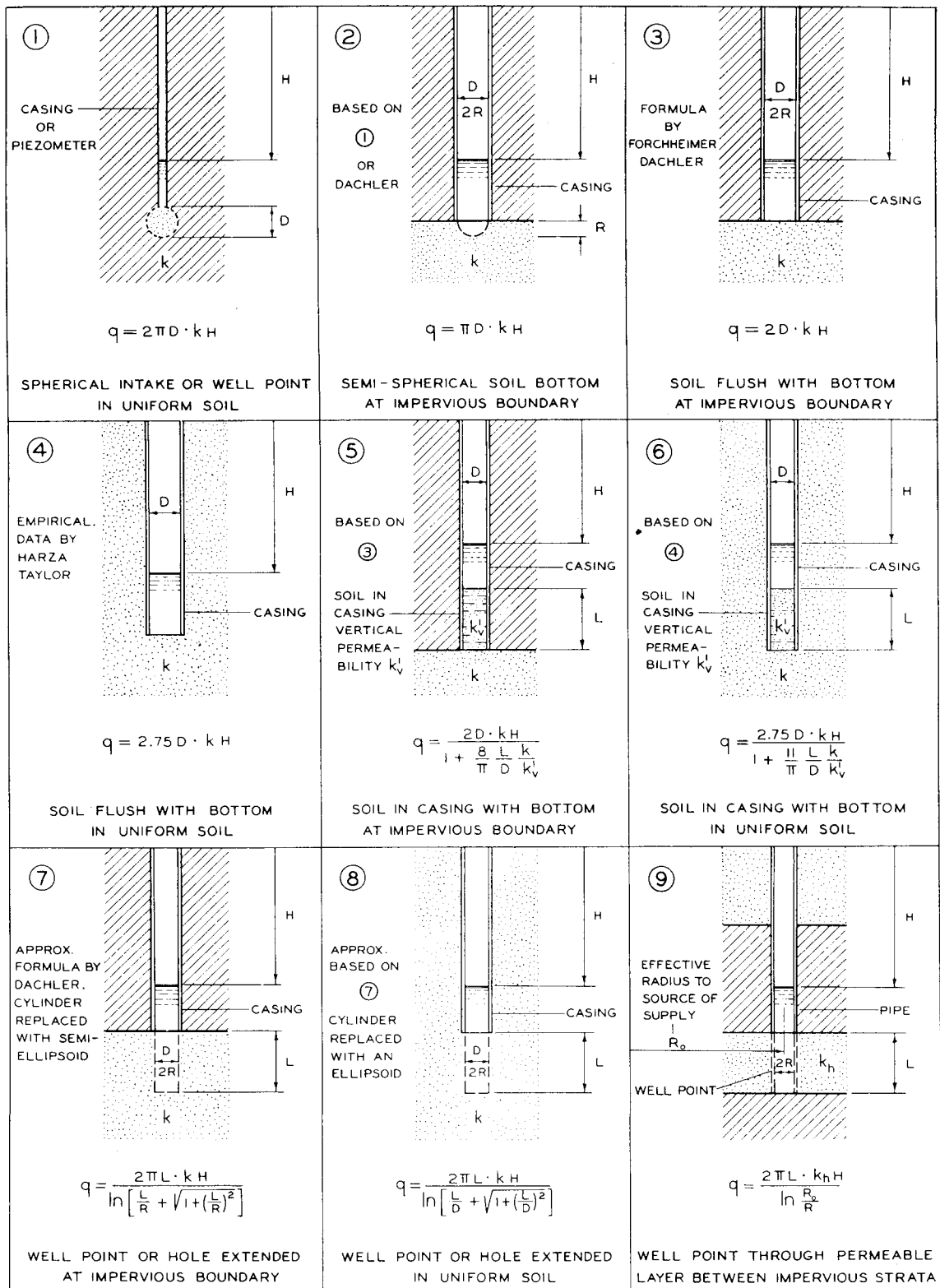

q = RATE OF FLOW IN cm^3/SEC , H = HEAD IN CM, k = COEF. OF PERMEABILITY IN cm/SEC , $\ln = \log_e$, DIMENSIONS IN CM.

CASES 1 TO 8: UNIFORM PERMEABILITY AND INFINITE DEPTH OF PERVIOUS STRATUM ASSUMED

FORMULAS FOR ANISOTROPIC PERMEABILITY GIVEN IN TEXT

Fig. 12. Inflow and shape factors

In this form the formulas were derived earlier by SAMSIOE (26). When L/R or L/D is greater than four, the error resulting from use of the simplified formulas is less than one per cent. In Case 9 the flow lines are horizontal and the coefficient of horizontal permeability, k_h , is governing. The effective radius, R_o , depends on the distance to the source of supply and to some extent on the compressibility of the soil, MUSKAT (22) and JACOB (17, 18). It may be noted that the simplified formula for Case 7 is identical with the formula for Case 9 when $R_o = 2L$. For flow through wells with only partial penetration of the pervious stratum, reference is made to MUSKAT (22) and the paper by MIDDLEBROOKS and JERVIS (21).

The assumptions, on which the derivation of the formulas in Fig. 12 are based, are seldom fully satisfied under practical conditions. It is especially to be noted that the horizontal permeability of soil strata generally is much larger than the vertical permeability. Correction of the formulas for the effect of anisotropic permeability is discussed in the following section. Even when such corrections are made, the formulas should be expected only to yield approximate results, since the soil strata are not infinite in extent and are rarely uniform in character. However and taking into consideration that the permeability characteristics of the soil strata seldom are accurately known in advance, the formulas are generally adequate for the purpose of preliminary design or selection of the proper type of pressure measuring installation, but the basic time lag obtained by the formulas should always be verified and corrected by means of field experiments.

Influence of Anisotropic Permeability

As first demonstrated by SAMSIOE (26) and later by DACHLER (6) for two-dimensional or plane problems of flow through soils, the influence of a difference between the coefficients of vertical and horizontal permeability of the soil, k_v and k_h , may be taken into consideration by multiplying all horizontal dimensions by the factor $\sqrt{k_v/k_h}$ and using the mean permeability $k_m = \sqrt{k_v \cdot k_h}$, whereafter formulas or flow nets for isotropic conditions may be used.

A general solution for three-dimensional problems and different but constant coefficients of permeability k_x , k_y , and k_z in direction of the coordinate axes is given by VREEDENBURG (31) and MUSKAT (22). With k_o an arbitrarily selected coefficient, the following transformation is made,

$$x' = x \sqrt{k_o/k_x} \qquad y' = y \sqrt{k_o/k_y} \qquad z' = z \sqrt{k_o/k_z} \qquad (28)$$

and when an equivalent coefficient of permeability

$$k_e = k_o \sqrt{\frac{k_x}{k_o} \cdot \frac{k_y}{k_o} \cdot \frac{k_z}{k_o}} \qquad (29)$$

is used, then the problem may be treated as if the conditions were isotropic. In applying these transformations to problems of flow through intakes or well points in soil with horizontal isotropic permeability, k_h , and vertical permeability k_v , it is convenient to use the following substitutions,

$$k_o = k_z = k_v \quad k_x = k_y = k_h \quad \text{and} \quad m = \sqrt{k_h/k_v} \quad (30)$$

whereby the transformations assume the following form,

$$x' = x/m \quad y' = y/m \quad \text{or} \quad r' = r/m \quad \text{and} \quad z' = z \quad (31)$$

$$k_e = k_v \sqrt{m^2 \cdot m^2} = k_v \cdot m^2 = k_h \quad (32)$$

That is, the problems can be treated as for isotropic conditions when the horizontal dimensions are divided by the square root of the ratio between the horizontal and vertical coefficients of permeability and the flow through the transformed well points is computed for a coefficient of permeability equal to k_h . When these transformations are applied to Cases 1 and 2 in Fig. 12, the sphere and semi-sphere become an ellipsoid, respectively a semi-ellipsoid, and formulas corresponding to those for Cases 7 and 8 should then be used. In Cases 5 and 6 the transformations should be applied only to flow through soil below the casing and not to soil within the casing. With introduction of the mean coefficient of permeability,

$$k_m = \sqrt{k_v \cdot k_h} = m \cdot k_v = k_h/m \quad (33)$$

the flow through the intakes and well points shown in Fig. 12 can be expressed as follows:

$$\text{CASE 1.} \quad q = \frac{2\pi D k_h H}{\ln(m + \sqrt{1 + m^2})}$$

$$\text{CASE 2.} \quad q = \frac{\pi D k_h H}{\ln(m + \sqrt{1 + m^2})}$$

$$\text{CASE 3.} \quad q = 2 D k_m H$$

$$\text{CASE 4.} \quad q = 2.75 D k_m H$$

$$\text{CASE 5.} \quad q = \frac{2 D k_m H}{1 + \frac{8 L k_m}{\pi D k_v}}$$

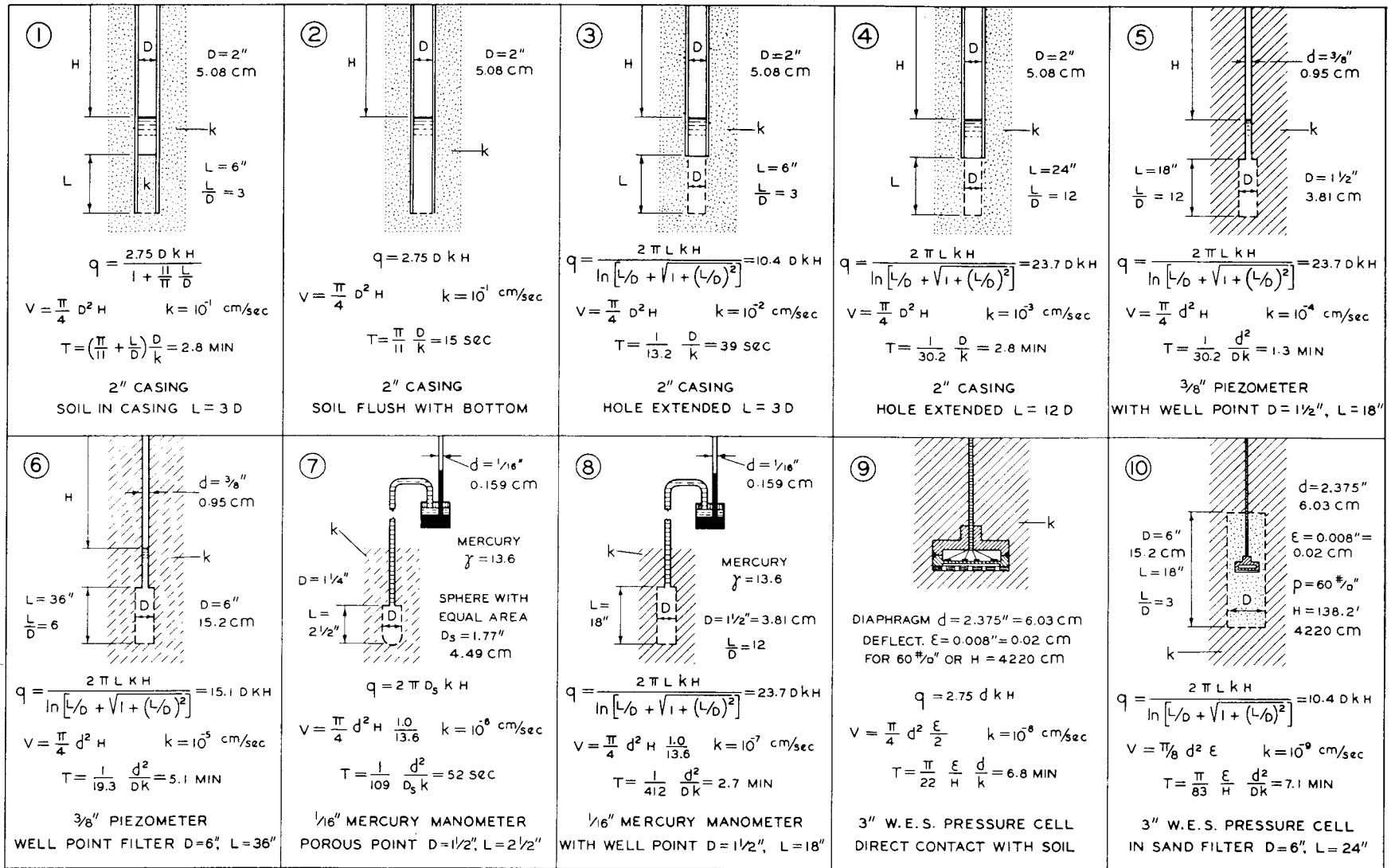

q = RATE OF FLOW FOR HEAD H , V = TOTAL VOLUME OF FLOW TO EQUALIZE PRESSURES, $T = V/q$ = BASIC TIME LAG, ISOTROPIC SOIL CONDITIONS ASSUMED

Fig. 13. Examples of computation of basic time lag

$$\text{CASE 6. } q = \frac{2.75 D k_m H}{1 + \frac{11 L k_m}{\pi D k_v}}$$

$$\text{CASE 7. } q = \frac{2 \pi L k_h H}{\ln (mL/R + \sqrt{1 + (mL/R)^2})}$$

$$\text{CASE 8. } q = \frac{2 \pi L k_h H}{\ln (mL/D + \sqrt{1 + (mL/D)^2})}$$

The formula for Case 9 in Fig. 12 is already expressed in terms of the horizontal permeability and is not affected by the transformation. The modified formulas for Cases 1 and 2 should be considered as being only approximately correct, and for isotropic conditions or $m = 1$ they yield 13.4 per cent greater values of flow than obtained by the basic formulas in Fig. 12. In Cases 7 and 8 and for large values of mL/R or mL/D the denominators may be replaced with $\ln (2mL/R)$, respectively $\ln (2mL/D)$.

Computation of Time Lag for Design Purposes

Examples of computation of the basic time lag, using the flow formulas in Fig. 12, are shown in Fig. 13. In all cases it is assumed that the soil is uniform and the permeability equal in all directions; this applies also to soil in the casing as shown in Case 1. The porous cup point in Case 7 is replaced with a sphere of equal surface area and the flow computed as through a spherical well point. This transformation furnishes a time lag which is slightly too small, since flow through a spherical well point is greater than through a point of any other shape and equal surface area. The pressure cell shown in Cases 9 and 10 is similar to the one described in a report by the WATERWAYS EXPERIMENT STATION (33). It may be noted that hydrostatic pressure cells with a diaphragm diameter of only 3/4 in. have been built and used successfully by the Waterways Experiment Station, and that a pressure cell with a diaphragm diameter of about one inch is described in a paper by BOITEN and PLANTEMA (1); see also Fig. 8-B. It is emphasized that the basic time lags for Cases 9 and 10 are computed on the assumption that there is no accumulation of gases below the diaphragm or in the sand filter; see discussion on pages 7 and 8.

A few general rules may be deduced from the examples shown in Fig. 13. In all cases the basic time lag is inversely proportional to the coefficient of permeability. When the ratio between the effective length and the diameter of the intake,

TIME LAGS		FOR 90 PERCENT EQUALIZATION = T_{90}										BASIC TIME LAG T
		SAND			SILT			CLAY				
APPROXIMATE SOIL TYPE		10^{-1}	10^{-2}	10^{-3}	10^{-4}	10^{-5}	10^{-6}	10^{-7}	10^{-8}	10^{-9}	10^{-10}	10^{-6}
COEFFICIENT OF PERMEABILITY IN CM/SEC												
1	2" CASING - SOIL IN CASING, L = 3D = 6"	6 ^m	1 ^h	10 ^h	4.2 ^d							193 ^d
2	2" CASING - SOIL FLUSH BOTTOM CASING	0.6 ^m	6 ^m	1 ^h	10 ^h	4.2 ^d						17 ^d
3	2" CASING - HOLE EXTENDED, L = 3D = 6"		1.5 ^m	15 ^m	2.5 ^h	25 ^h	10 ^d					4.5 ^d
4	2" CASING - HOLE EXTENDED, L = 12D = 24"			6 ^m	1 ^h	10 ^h	4.2 ^d	42 ^d				47 ^h
5	3/8" PIEZOMETER WITH WELL POINT DIAMETER 1/2", LENGTH 18"				3 ^m	30 ^m	5 ^h	50 ^h	21 ^d			130 ^m
6	3/8" PIEZOMETER WITH WELL POINT AND SAND FILTER, D = 6", L = 36"					12 ^m	2 ^h	20 ^h	8.3 ^d	83 ^d		51 ^m
7	1/16" MERCURY MANOMETER, SINGLE TUBE WITH POROUS CUP POINT, D = 1/4", L = 2 1/2"		ONE-HALF OF VALUES FOR 1/16" MERCURY U-TUBE MANOMETER OR 4 1/2" BOURDON GAGE.				2 ^m	20 ^m	3.3 ^h	33 ^h	14 ^d	52 ^s
8	1/16" MERCURY MANOMETER, SINGLE TUBE WITH WELL POINT, D = 1 1/2", L = 18"									6 ^m	1 ^h	10 ^h
9	3" W. E. S. HYDROSTATIC PRESSURE CELL IN DIRECT CONTACT WITH SOIL								16 ^m	2.6 ^h	26 ^h	4 ^s
10	3" W. E. S. HYDROSTATIC PRESSURE CELL IN SAND FILTER, D = 6", L = 18"									16 ^m	2.6 ^h	0.4 ^s

SYMBOLS: s = SECONDS, m = MINUTES, h = HOURS, d = DAYS - ASSUMPTIONS: CONSTANT GROUND-WATER PRESSURE AND INTAKE SHAPE FACTOR, ISOTROPIC SOIL, NO GAS, STRESS ADJUSTMENT TIME LAG NEGLIGIBLE. THE COMPUTED TIME LAGS HAVE BEEN ROUNDED OFF TO CONVENIENT VALUES

Fig. 14. Approximate hydrostatic time lags

L/D , remains constant, the basic time lag is inversely proportional to the diameter of the intake and directly proportional to the cross-sectional area or the square of the diameter of the piezometer or manometer tube. When furthermore the diameters of the intake and piezometer are equal, Cases 1 to 4, the basic time lag is directly proportional to the diameter.

The results of the examples in Fig. 13 are summarized in a slightly different form in the last column in Fig. 14. The basic time lags are here given for a coefficient of permeability $k = 10^{-6}$ cm/sec., and these time lags may be used as a rating of the response to pressure changes for the various types of installations. For the examples shown in Figs. 13 and 14 this rating time lag varies from 193 days for a 2-in. boring with 6 in. of soil in the casing to 0.4 seconds for a 3-in. pressure cell placed in a 6-in. by 18-in. sand filter.

In the central part of Fig. 14 the basic time lags for various coefficients of permeability have been multiplied by 2.3 and indicate the time lags for 90 per cent equalization of the original pressure difference, which approximately is the time lag to be considered in practical operations. As mentioned on page 12, the time lag for 99 per cent equalization is twice as great as for 90 per cent equalization. According to data furnished the writer by Dr. A. WARLAM, the volume change of a 4-1/2-in. Bourdon pressure gage is 0.5 to 1.0 cm³ for 1.0 kg/cm² change in pressure, or approximately half of that for a 1/16-in., single-tube, mercury manometer. Therefore, when the standpipe in Cases 7 and 8 is connected to a 4-1/2-in. Bourdon gage or to a double-tube mercury manometer with 1/16-in. inside diameter, the time lags will be about one-half those shown for a 1/16-in., single-tube mercury manometer. It is possible that the above mentioned volume change for a Bourdon pressure gage includes deformations of pliable rubber or plastic tube connections used in the experiments, and that the volume changes and corresponding time lags are smaller when rigid connections are used.

In all cases the computed time lags should be considered as being only approximate values, and they have been rounded off to convenient figures. The actual time lags may be influenced by several factors not taken into consideration in the above mentioned computations, such as stress adjustment and volume changes of soil and gases in the soil or pressure measuring system, sedimentation or clogging of the well point, filter, or surrounding soil, etc. The actual time lags may therefore be considerably greater or smaller than those indicated in Figs. 13 and 14, and special attention is called to the fact that the horizontal permeability of the soil, because of stratifications, often is many times greater than the vertical permeability as generally determined by laboratory tests and often used as a measure of the permeability of the soil stratum as a whole. Nevertheless, the examples shown in Figs. 13 and 14 will furnish some indication of the relative responsiveness of the various types of installations and permit a preliminary selection of the type suited for specific conditions and purposes.

Examples of Field Observations and Their Evaluation

Logan International Airport, Boston

Observations of pore-water pressures in the foundation soil of Logan International Airport at Boston are described in papers by CASAGRANDE (3) and GOULD (10). Most of the piezometers used were of the Casagrande type, shown diagrammatically in Fig. 15-A. The results of a series of time lag tests for piezometer C are

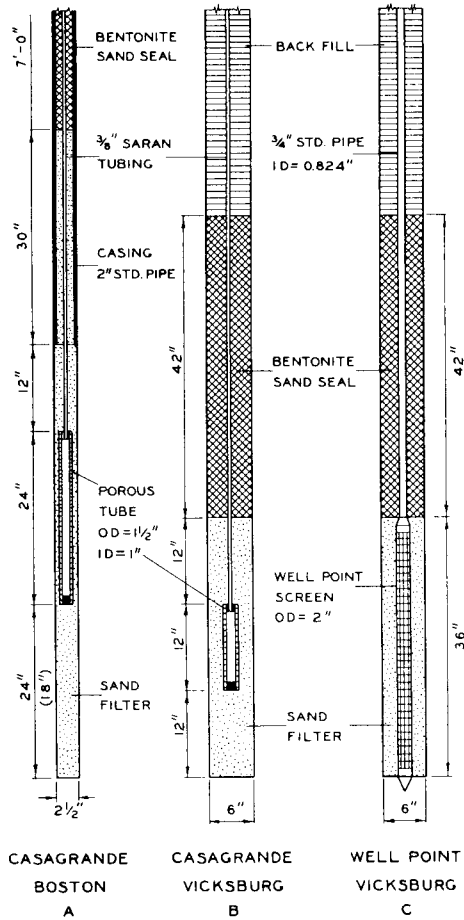

Fig. 15. Piezometers used in tests

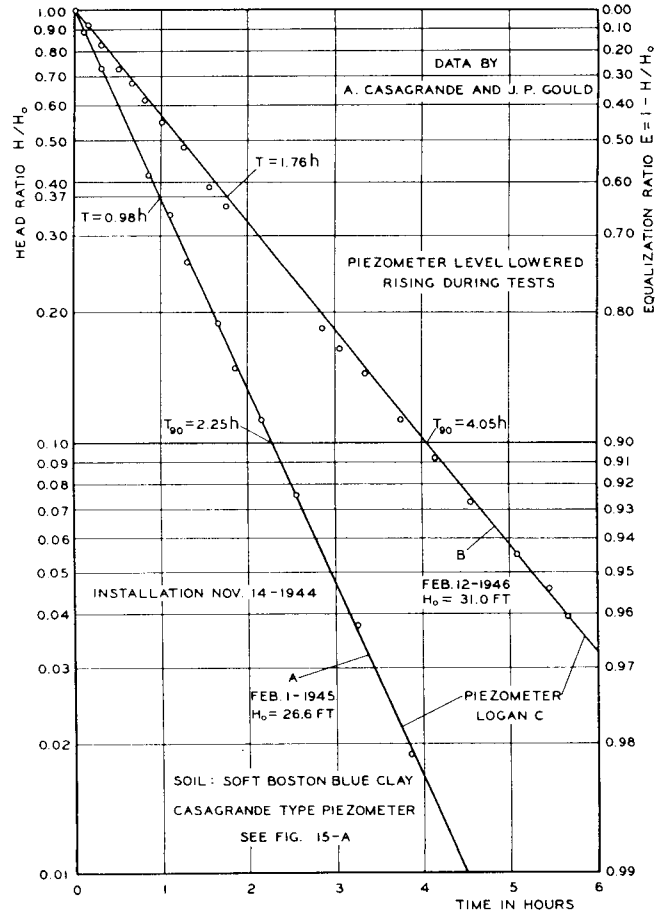

Fig. 16. Time lag tests at Logan Airport, Boston

summarized in the paper by GOULD and further details were placed at the writer's disposal by CASAGRANDE. The filter or intake for this piezometer is installed in soft Boston Blue clay at a depth of 47 ft below the finished grade of fill.

The equalization diagrams obtained in two of the above mentioned tests, performed a year apart, are shown in Fig. 16. The first of these diagrams is straight,

thereby indicating that the influence of transient stress adjustments or volume changes of the soil and gas in the voids is negligible; the basic time lag determined by this diagram is 0.98 hours. The equalization diagram obtained a year later shows a slight curvature and a basic time lag of 1.76 hours. Since the curvature is very small, the increase in time lag is probably caused by clogging of the porous tube or point and the filter. Estimates of the coefficients of permeability of the soil were obtained by means of new methods of settlement analysis, GOULD (10), and it was found that k_v varies between $(28 \text{ and } 35) \times 10^{-9}$ cm/sec and k_h between $(940 \text{ and } 1410) \times 10^{-9}$ cm/sec. Using the average values $k_v = 31.5 \times 10^{-9}$ cm/sec and $k_h = 1175 \times 10^{-9}$ cm/sec, the transformation ratio, m , is then

$$m = \sqrt{k_h/k_v} = \sqrt{37.5} = 6.1$$

The dimensions of the installation as given in the paper by GOULD are: diameter of filter $D = 2.5$ in. = 6.35 cm; length of filter $L = 54$ in. = 137.2 cm; inside diameter of piezometer $d = 0.375$ in. = 0.95 cm. The rate of flow for the active head H is obtained by the simplified formula for Case 8 on page 35

$$q = \frac{2\pi L k_h H}{\ln(2mL/D)}$$

and the total volume of flow required for equalization is,

$$V = \frac{\pi}{4} d^2 H$$

The basic time lag as determined by equation 3 is then,

$$T = \frac{V}{q} = \frac{d^2 \ln(2mL/D)}{8 L k_h} = \frac{0.95^2 \ln(263.6)}{8 \cdot 137.2 \cdot 1175} 10^9 = 3910 \text{ sec} = 1.09 \text{ hours} \quad (34)$$

which agrees closely with the actual time lag, $T = 0.98$ hours.

Vicinity of Vicksburg, Mississippi

A preliminary series of comparative tests with various types of observation wells and piezometers has been performed by the WATERWAYS EXPERIMENT STATION (34). The wells and piezometers were installed behind the Mississippi River levees at two locations, Willow Point and Reid Bedford Bend. Time lag tests were made one to eight months after installation, and some of the equalization diagrams obtained in these tests are shown in Fig. 17. All the diagrams show a distinct initial curvature, and the period of observations was often too short, covering only the first and curved part of the diagrams. It was observed that gas emerged from some of the piezometers, and it is probable that the initial curvature of the equalization diagrams is caused by transient volume changes of gas bubbles accumulated in the

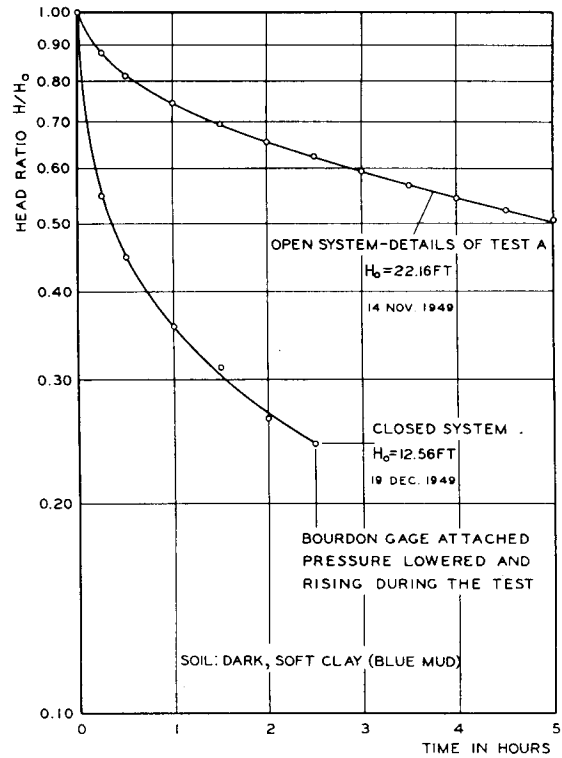
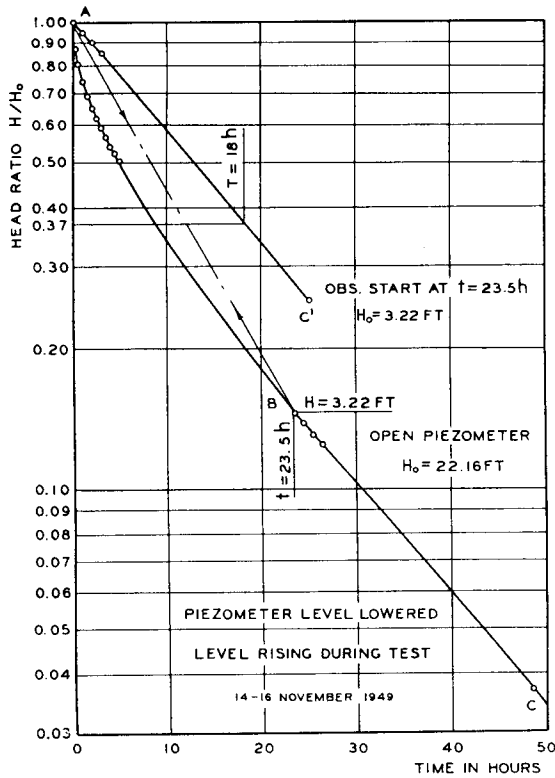

WILLOW POINT PIEZOMETER NO. 1 - CASAGRANDE TYPE FIG. 15-B

A - EXTENDED TESTS OPEN SYSTEM

B - DETAILS OPEN AND CLOSED SYSTEMS

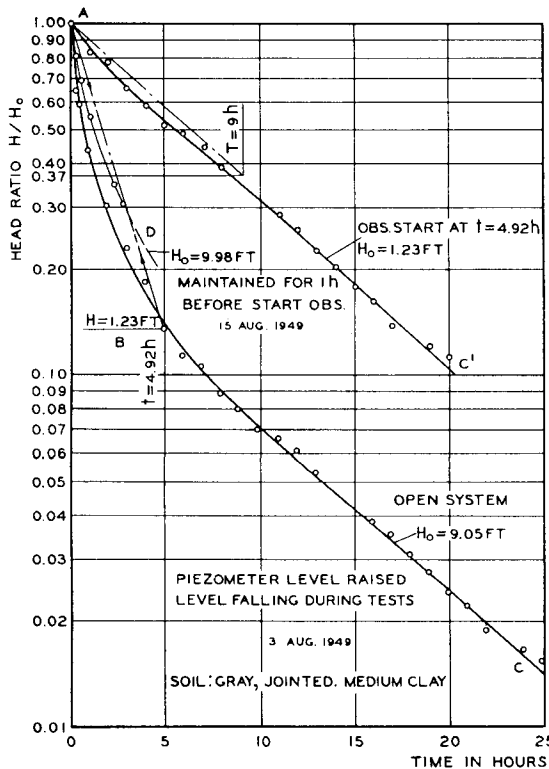

CASAGRANDE TYPE PIEZOMETER FIG. 15-B

C - REID BEDFORD PIEZOMETER NO. 8

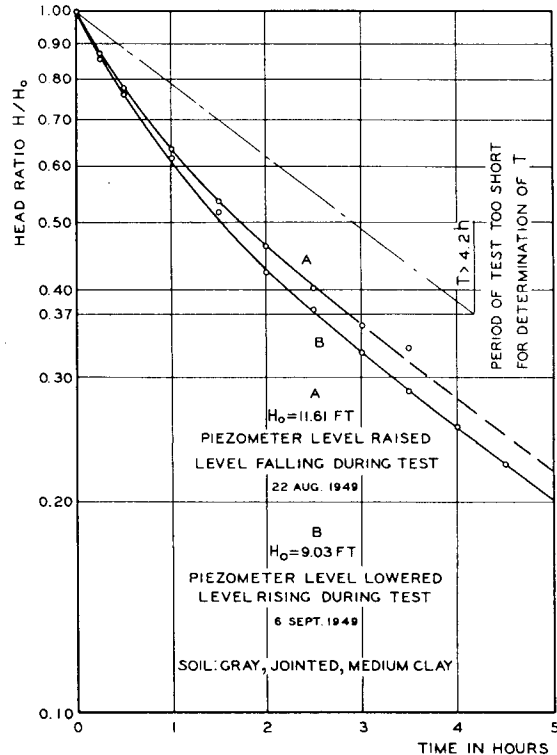

WELL POINT WITH SAND FILTER FIG. 15-C

D - REID BEDFORD PIEZOMETER NO. 10

Fig. 17. Time lag tests by the Waterways Experiment Station, Vicksburg

soil near the well points or filters. The individual piezometers in the two groups are only 15 ft apart, and it is possible that time lag tests on a piezometer to a minor extent were influenced by flow to or from neighboring piezometers.

Laboratory tests on soil samples from the vicinity of the intakes for these installations indicate that the coefficients of vertical permeability vary between $(10 \text{ and } 150) \times 10^{-9}$ cm/sec. Data on the coefficients of horizontal permeability are not available, and the soils at Reid Bedford Bend were jointed. Therefore, reliable estimates of the theoretical basic time lags cannot be made, but the basic time lags obtained by means of the equalization diagrams fall between those computed on basis of isotropic conditions and coefficients of permeability equal to the above mentioned upper and lower limits of the coefficients of vertical permeability.

Piezometer No. 1 at Willow Point is of the modified Casagrande type, Fig. 15-B, and is installed 92.5 ft below ground surface in a soft dark clay, locally known as "blue mud." The first part of the equalization diagram, Fig. 17-A, is curved but the lower part is fairly straight, possibly with a slight reverse curvature. If the observations are started 23.5 hours after the piezometer level was lowered, the diagram A-C' would be obtained; this diagram is parallel to the lower part, B-C, of the main diagram. As indicated on page 28, it is probable that the effective equalization diagram for the piezometer under normal operating conditions may be represented by a straight line through the origin and parallel to the lower and fairly straight part of the diagram obtained in a time lag test. By drawing such a line in Fig. 17-A, an effective basic time lag $T = 18$ hours is obtained.

In a second time lag test a Bourdon pressure gage was attached to the piezometer so that a closed system was formed. The pressure in the system was lowered by bleeding off a small amount of water, but the piezometric pressure level was above the gage level throughout the test. The equalization diagram obtained by observing the subsequent rise in pressure, Fig. 17-B, is lower and has considerably greater curvature than the one for an open system, which can be explained by the fact that the total amount of flow required for pressure equalization in the closed system is materially decreased, and the influence of volume changes of the gas bubbles and the soil consequently is greater.

Piezometer No. 8 at Reid Bedford is also of the modified Casagrande type and is installed 30 ft below ground surface in a gray, jointed, medium clay. The irregular, closely spaced joints in this clay are probably caused by previous drying, and the surfaces of some of the joints are covered with a thin layer of silt, but the joints at the depth of the piezometer intake are probably closed. The equalization diagram, A-B-C in Fig. 17-C, shows a pronounced initial curvature, but the lower part of the diagram is fairly straight. A straight line through the origin and parallel to the lower part of the diagram indicates an effective basic time lag $T = 9$ hours. In a second test the head -- $H_0 = 9.98$ ft -- was maintained for one hour before the

piezometer level was allowed to fall and the observations were started. The resulting equalization diagram, A-D, is above the first diagram and not so strongly curved. If the full head had been maintained for at least 24 hours, it is probable that a diagram similar to A-C' or the lower portion, B-C, of the main diagram would have been obtained.

Piezometer No. 10 at Reid Bedford is installed 15 ft from piezometer No. 8 and at the same depth. The sand filter has the same dimensions as for No. 8, but the porous tube is replaced with a well point screen extending through the whole length of the filter, and the piezometer proper is a 3/4-in. standard pipe; Fig. 15-C. Equalization diagrams were obtained for both falling and rising piezometer levels and are shown in Fig. 17-D. The periods of observation are too short for definite determination of the effective basic time lag, which is greater than 4.2 hours but probably smaller than the 9 hours obtained for piezometer No. 8. The initial curvature of the diagrams is considerably less than that of the diagrams for piezometer No. 8, which may be explained by the fact that the cross-sectional area of the piezometer pipe is $(0.824/0.375)^2 = 4.8$ times as great and that the influence of volume changes of soil and gas bubbles consequently is smaller. However, the basic time lag should then also be 4.8 times as great, since the dimensions of the sand filters for piezometers 8 and 10 are identical, but the equalization diagrams indicate a smaller time lag. This inconsistency may be due to local joints and other irregularities in soil conditions, but it is also probable that the well point screen is less subject to clogging than a porous tube, and that gases can escape more easily since the screen extends to the top of the sand filter.

Piezometer No. 11 at Reid Bedford consists of a 3/4-in. standard pipe with its lower end in the center of a sand filter at the same depth and with the same dimensions as the filters for piezometers 8 and 10. The time lag observations for piezometer No. 11 are incomplete but indicate that the effective basic time lag is at least 25 hours. It is probable that this increase in time lag, in comparison with piezometers 8 and 10, is caused by clogging of the sand in the immediate vicinity of the end of the pipe and of sand which may have entered the lower part of the pipe. Cleaning of the pipe and subsequent careful surging would undoubtedly decrease the time lag, but it is probable that clogging would re-occur in time.

Piezometer No. 15 at Reid Bedford is a 3/4-in. standard pipe with a solid drive point and a 4-in.-long, perforated section above the point. The pipe was driven to the same depth as the other piezometers and then withdrawn one foot. In a time lag test the piezometer level was raised 7.48 ft, and in 22.7 hours it fell only 0.12 ft. The lower part of the equalization diagram, during which the piezometer level fell from 7.45 ft to 7.36 ft in 17 hours, is fairly straight. For such a small drop in piezometer level it is better to compute the effective basic time lag by means of equation (5) than to determine it graphically; that is,

$$T = \frac{t}{\ln (H_o/H)} = \frac{17}{\ln (7.45/7.36)} = 1730 \text{ hours} = 72 \text{ days} \quad (35)$$

Because of the solid drive point, it is doubtful that withdrawal of the pipe for one foot materially affects flow to or from the perforated section, and the effective length of the latter would then be less than 4 in., even when the perforations remain open. However, it is possible that the perforations have been filled with molded soil during the driving, that a smear layer of remolded soil is formed around the pipe, and that this layer has covered the joints in the clay and decreased its effective permeability.

Determination of Permeability of Soil in Situ

Basic formulas

When the dimensions or shape factor, F , of a pressure measuring installation are known, it is theoretically possible to determine the coefficients of permeability of the soil in situ by field observations.

For constant head, H_c , and rate of flow, q , equation (1) yields,

$$k = \frac{q}{F H_c} \quad (36)$$

For variable head but constant ground-water level or pressure, the heads H_1 and H_2 corresponding to the times t_1 and t_2 , and $A = \frac{\pi}{4} d^2$ the cross-sectional area of the standpipe, the following expression is obtained by means of equation (5),

$$t_2 - t_1 = T \left(\ln \frac{H_o}{H_2} - \ln \frac{H_o}{H_1} \right) = \frac{A}{F k} \ln \frac{H_1}{H_2}$$

$$k = \frac{A}{F (t_2 - t_1)} \ln \frac{H_1}{H_2} \quad (37)$$

This is also the formula commonly used for determination of coefficients of permeability in the laboratory by means of a variable head permeameter.

The simplest expression for the coefficient of permeability is obtained by determination of the basic time lag, T , of the installation and use of equation (3); that is,

$$k = \frac{A}{F T} \quad (38)$$

The shape factors, F , for various types of observation wells and piezometers may be obtained from the formulas in Fig. 12 and on pages 33 and 35 by eliminating the factors (kH) , respectively $(k_m H)$ or $(k_h H)$, from the right side of the

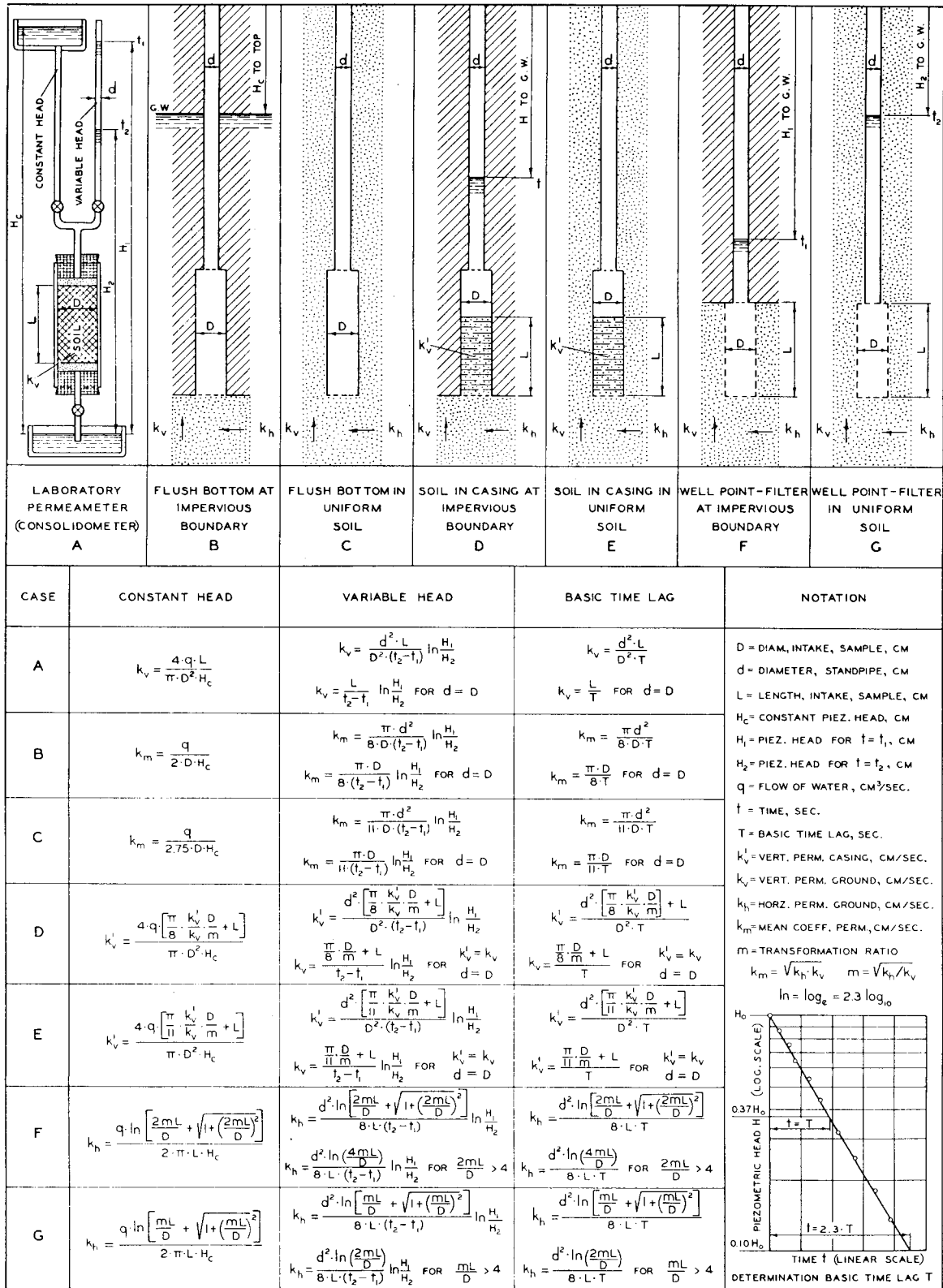

ASSUMPTIONS

SOIL AT INTAKE, INFINITE DEPTH AND DIRECTIONAL ISOTROPY (k_v AND k_h CONSTANT) - NO DISTURBANCE, SEGREGATION, SWELLING OR CONSOLIDATION OF SOIL - NO SEDIMENTATION OR LEAKAGE - NO AIR OR GAS IN SOIL, WELL POINT, OR PIPE - HYDRAULIC LOSSES IN PIPES, WELL POINT OR FILTER NEGLIGIBLE

Fig. 18. Formulas for determination of permeability

equations. Explicit formulas for determination of coefficients of permeability by constant head, variable head, and basic time lag tests with permeameters and various types of borings and piezometers are summarized in Fig. 18. For a permeameter, Case A, the rate of flow for the head H is $q = \frac{\pi}{4} D^2 kH/L$, or $F = \frac{\pi}{4} D^2/L$. In cases D and E the coefficient of vertical permeability of soil in the casing is usually governing, and the equations have been solved for this coefficient and appear in a form slightly different from that corresponding to Cases (5) and (6) in Fig. 12 and on pages 33 and 35. Simplified formulas for $d = D$, $k'_v = k_v$, and the ratio (mL/D) greater than 2 or 4, are given below the main formulas in each case.

The basic time lag is easily determined by means of an equalization diagram -- or a semilogarithmic plot of time versus head -- as the time T corresponding to $H = 0.37H_0$; i.e., $\ln(H_0/H) = 1$. The work involved in plotting the diagram is offset by simpler formulas for computing the coefficient of permeability, compared to the formulas for variable head, and the diagram has the great advantage that it reveals irregularities caused by volume changes or stress adjustment time lag and permits easy advance adjustment of the results of the tests. It is emphasized that the above mentioned methods and formulas are applicable only when the basic assumptions for the theory of time lag, page 9, are substantially correct.

Examples of applications

The following dimensions apply to the permeability tests on Atlantic muck, Fig. 10: $D = 4.25$ in. = 10.8 cm; $L = 0.87$ in. = 2.21 cm; $d = 0.30$ cm. The basic time lag obtained from the probable normal diagram in Fig. 10 is $T = 178$ minutes, and hence

$$k_v = \frac{d^2 L}{D^2 T} = \frac{0.30^2 \cdot 2.21}{10.8^2 \cdot 178 \cdot 60} = 159 \times 10^{-9} \text{ cm/sec.}$$

The slope of the lower parts of the equalization diagrams corresponds to a basic time lag $T = 210$ min and $k_v = 135 \times 10^{-9}$ cm/sec. Larger basic time lags and correspondingly smaller values of the coefficients of permeability were obtained in similar tests with other undisturbed samples of Atlantic muck.

The first test with piezometer C at Logan International Airport, Fig. 16, gave a basic time lag $T = 0.98$ hours = 3530 seconds. With $k_v = 31.5 \times 10^{-9}$ cm/sec and the dimensions given on page 39, the coefficient of horizontal permeability of Boston Blue clay may be determined as follows:

$$k_h = \frac{d^2 \ln(2mL/D)}{8 \cdot L \cdot T} = \frac{0.95^2 \ln(m \cdot 43.2)}{8 \cdot 137.2 \cdot 3530} = 233.5 \cdot 10^{-9} \cdot \ln(m \cdot 43.2)$$

This equation may be solved by estimating the value of $m = \sqrt{k_h/k_v}$ and successive corrections, which yield

$$k_h = 1310 \times 10^{-9} \text{ cm/sec} \quad \text{and} \quad k_h/k_v = 1310/31.5 = 41.6$$

These values lie within the limits obtained by other methods, GOULD (10), and discussed on page 39.

The second time lag test with piezometer C gave $T = 1.76$ hours and indicated thereby that clogging of the porous tube had taken place. Therefore, reliable values of the coefficient of permeability can no longer be obtained by means of this installation. This applies also to the installations at Willow Point and Reid Bedford, Fig. 17, since the strong initial curvature of the equalization diagrams indicates large transient volume changes and probably accumulation of gas bubbles in the sand filters and surrounding soil with a consequent decrease in permeability of this soil and increase in time lag.

Advantages and limitations

Observation of the basic time lag for borings and piezometers provides theoretically a very simple method for determination of the permeability of soil in situ, even for anisotropic conditions. However, many difficulties are encountered in the practical execution of such permeability tests and evaluation of the results obtained, since the latter are subject to the same sources of error as those of pressure observations discussed in Part I, and since methods of correction for the influence of some of these sources of error have not yet been devised.

The shape factor of the installation must be computed, but some of the formulas in Figs. 12 and 18 are empirical or only approximately correct, and they are all based on the assumption of infinite thickness of the soil layer in which the well point or intake is installed. When sand filters are used, the dimensions must be determined with greater accuracy than is required for pressure observations. The greatest part of the hydraulic friction losses occur near the intake, and the results of a test consequently indicate the permeability of the soil in the immediate vicinity of the intake. Misleading results are obtained when the permeability of this soil is changed by disturbance of the soil during advance of a bore hole or installation of filters or well points. Leakage, clogging of the intake or removal of fine-grained particles from the surrounding soil, and accumulation of gases near the intake or within the pressure measuring system may render the installation wholly unreliable as a means of determining the permeability of the undisturbed soil. Gas bubbles in the soil near the intake will decrease the permeability, cause curvature of the equalization diagram, and increase the effective basic time lag. Gas bubbles in a coarse-grained filter or within the pressure measuring system will not cause any

appreciable curvature of the equalization diagram but will materially decrease the slope of the diagram and increase the basic time lag so that too small values of the coefficients of permeability are obtained.

Many of the above mentioned sources of error are avoided in the commonly used pumping tests, during which the shape of the draw-down curve is determined for a given rate of flow, but such tests are expensive and time consuming. Determination of the permeability of soil in situ by means of the time lag of observation wells and piezometers has so many potential advantages that it is to be hoped that systematic research will be undertaken in an effort to develop reliable methods of calibration or experimental determination of shape factors, and also of methods for detection, correction, or elimination of the various sources of error in the observations. Until such research is successfully completed, it is advisable to exert great caution in the practical application of the results obtained by the method.

REFERENCES

- ✓ 1. BOITEN, R. G. and PLANTEMA, G., An Electrically Operating Pore Water Pressure Cell. Proc. Second Int. Conf. Soil Mech., Rotterdam 1948, v. 1, p. 306-309.
2. CASAGRANDE, A., Piezometers for Pore Pressure Measurement in Clay. Memorandum. Graduate School of Engineering, Harvard University, Cambridge, Mass., July 1946.
3. CASAGRANDE, A., Soil Mechanics in the Design and Construction of the Logan International Airport. Journal Boston Society of Civil Engineers, April 1949, v. 36, p. 192-221.
4. CHRISTIANSEN, J. E., Effect of Trapped Air on Soil Permeability. Soil Science, 1944, v. 58, p. 355-365.
- ✓ 5. CUPERUS, J. L. A., Permeability of Peat by Water. Proc. Second Int. Conf. Soil Mech., Rotterdam 1948, v. 1, p. 258-264.
6. DACHLER, R., Grundwasserströmung (Flow of Ground Water). 141 p. Julius Springer, Wien 1936.
- ✓ 7. DE BEER, E. and RAEDSCHELDERS, H., Some Results of Waterpressure Measurements in Clay Layers. Proc. Second Int. Conf. Soil Mech., Rotterdam 1948, v. 1, p. 294-299.
8. FIELDS, K. E. and WELLS, W. L., Pendleton Levee Failure. Paper contains drawing and description of piezometer and pressure gage, p. 1402. A second pore-water pressure gage is described in a discussion by R. B. Peck, p. 1415. Trans. Am. Soc. Civ. Eng., 1944, v. 109, p. 1400-1413. Discussions p. 1414-1429.
9. FORCHHEIMER, PH., Hydraulik (Hydraulics), 3 ed., 596 p. B. G. Teubner, Leipzig und Berlin, 1930.
- ✓ 10. GOULD, J. P., Analysis of Pore Pressure and Settlement Observations at Logan International Airport. Harvard Soil Mechanics Series No. 34, Department of Engineering, Harvard University, Cambridge, Mass., December 1949.
11. HARDING, H. J. B., Some Recorded Observations of Ground Water Levels Related to Adjacent Tidal Movements. Proc. Second Int. Conf. Soil Mech., Rotterdam 1948, v. 4, p. 317-323.
12. HARZA, L. F., Uplift and Seepage under Dams. Paper contains results of model tests to determine inflow into wells. Trans. Am. Soc. Civ. Eng., 1935, v. 100, p. 1352-1385. Discussions p. 1386-1406.
13. HUIZINGA, T. K., Measurement of Pore Water Pressure. Proc. Second Int. Conf. Soil Mech., Rotterdam 1948, v. 1, p. 303-306.

14. HVORSLEV, M. J., Discussion of paper by George L. Freeman, The Application of Soil Mechanics in the Building of the New York Worlds Fair. Discussion deals with the need of and methods for determination of pore-water pressures. Presented at the ASCE Meeting, New York, Jan. 1940.
15. HVORSLEV, M. J., Survey of Methods for Field and Laboratory Investigation of Soils. Report to the Waterways Experiment Station, Corps of Engineers, Vicksburg, Miss., June 1941.
16. HVORSLEV, M. J., Subsurface Exploration and Sampling of Soils for Civil Engineering Purposes. Report on a research project of the American Society of Civil Engineers, sponsored by the Engineering Foundation, Harvard University, Waterways Experiment Station. Final printing 521 p., November 1949. Obtainable through the Engineering Foundation, New York.
17. JACOB, C. E., On the Flow of Water in an Elastic Artesian Aquifer. Trans. American Geophysical Union, 1940, v. 21, p. 574-586.
18. JACOB, C. E., Drawdown Test to Determine Effective Radius of Artesian Well. Trans. Am. Soc. Civ. Eng., 1947, v. 112, p. 1047-1064. Discussions p. 1065-1070.
19. KIRKHAM, D., Proposed Method for Field Measurement of Permeability of Soil below the Water Table. Proc. Soil Science Soc. Amer., 1947, v. 12, p. 54-60.
20. MEINZER, O. E., Hydrology. Volume IX of Physics of the Earth. 712 p. McGraw-Hill Book Co., New York and London, 1942.
21. MIDDLEBROOKS, T. A. and JERVIS, W. H., Relief Wells for Dams and Levees. Trans. Am. Soc. Civ. Eng., 1947, v. 112, p. 1321-1338. Discussions p. 1339-1402.
22. MUSKAT, M., The Flow of Homogeneous Fluids through Porous Media. 737 p. McGraw-Hill Book Co., New York and London, 1937.
23. RICHARDS, L. A. and GARDNER, W., Tensiometer for Measuring the Capillary Tension of Soil Water. Jour. Amer. Soc. Agron., 1936, v. 28, p. 352-358.
24. RICHARDS, L. A., Soil Moisture Tensiometer Materials and Construction. Soil Science, 1942, v. 53, p. 241-248.
25. ROGERS, W. S. A., A Soil Moisture Meter. Jour. Agr. Science, 1935, v. 25, p. 326-343.
26. SAMSIOE, A. F., Einfluss von Rohrbrunnen auf die Bewegung des Grundwassers (Influence of Wells on the Movement of Ground Water). Zeitschrift für angewandte Mathematik und Mechanik, April 1931, v. 11, p. 124-135.
27. SPEEDIE, M. G., Experience Gained in the Measurement of Pore Pressures in a Dam and its Foundation. Proc. Second Int. Conf. Soil Mech., Rotterdam 1948, v. 1, p. 287-294.
28. TAYLOR, D. W., Fundamentals of Soil Mechanics. 700 p. John Wiley & Sons, New York, 1948.

29. TERZAGHI, K., Measurement of Pore Water Pressure in Silt and Clay. Civil Engineering, 1943, v. 13, p. 33-36.
30. TOLMAN, C. F., Ground Water. 593 p. McGraw-Hill Book Co., New York and London, 1937.
31. VREEDENBURG, G. G. J., On the Steady Flow of Water Percolating through Soils with Homogeneous-Anisotropic Permeability. Proc. First Int. Conf. Soil Mech., Harvard 1936, v. 1, p. 222-225.
32. WALKER, F. C. and DAEHN, W. W., Ten Years of Pore Pressure Measurements. Proc. Second Int. Conf. Soil Mech., Rotterdam 1948, v. 3, p. 245-250.
33. WATERWAYS EXPERIMENT STATION, CORPS OF ENGINEERS, Soil Pressure Cell Investigation. Interim Report. The report also contains drawings and descriptions of hydrostatic pressure cells. Technical Memorandum No. 210-1, Vicksburg, Miss., 1944.
34. WATERWAYS EXPERIMENT STATION, CORPS OF ENGINEERS, Investigation of Pore Pressure Measuring Devices. Inter-office report in preparation; deals principally with various types of observation wells and piezometers.