

# Time-resolved in-cylinder PIV measurement in a light duty optical engine under PPC conditions

**Citation for published version (APA):**

Wang, H., Tanov, S., Izadi Najafabadi, M., Wang, Z., & Johansson, B. (2016). Time-resolved in-cylinder PIV measurement in a light duty optical engine under PPC conditions. In *Lisbon Symposium on the Application of Laser and Imaging Techniques to Fluid Mechanics*  
[http://lces.dem.ist.utl.pt/lxaser/lxaser2016/finalworks2016/papers/04.1\\_6\\_246paper.pdf](http://lces.dem.ist.utl.pt/lxaser/lxaser2016/finalworks2016/papers/04.1_6_246paper.pdf)

**Document license:**  
Unspecified

**Document status and date:**  
Published: 04/07/2016

**Document Version:**  
Publisher's PDF, also known as Version of Record (includes final page, issue and volume numbers)

**Please check the document version of this publication:**

- A submitted manuscript is the version of the article upon submission and before peer-review. There can be important differences between the submitted version and the official published version of record. People interested in the research are advised to contact the author for the final version of the publication, or visit the DOI to the publisher's website.
- The final author version and the galley proof are versions of the publication after peer review.
- The final published version features the final layout of the paper including the volume, issue and page numbers.

[Link to publication](#)

**General rights**

Copyright and moral rights for the publications made accessible in the public portal are retained by the authors and/or other copyright owners and it is a condition of accessing publications that users recognise and abide by the legal requirements associated with these rights.

- Users may download and print one copy of any publication from the public portal for the purpose of private study or research.
- You may not further distribute the material or use it for any profit-making activity or commercial gain
- You may freely distribute the URL identifying the publication in the public portal.

If the publication is distributed under the terms of Article 25fa of the Dutch Copyright Act, indicated by the "Taverne" license above, please follow below link for the End User Agreement:

[www.tue.nl/taverne](http://www.tue.nl/taverne)

**Take down policy**

If you believe that this document breaches copyright please contact us at:

[openaccess@tue.nl](mailto:openaccess@tue.nl)

providing details and we will investigate your claim.

# Time-Resolved In-cylinder PIV Measurement in a Light Duty Optical Engine under PPC Conditions

Hua Wang<sup>1,\*</sup>, Slavey Tanov<sup>2</sup>, Mohammad Izadi Najafabadi<sup>3</sup>, Zhenkan Wang<sup>4</sup>, Bengt Johansson<sup>2</sup>

1: Dantec Dynamics, Denmark

2: Div. of Combustion Engines, Lund University, Sweden

3: Dept. of mechanical Engineering, Technische Universiteit Eindhoven, Netherlands

4: Div. of Combustion Physics, Lund University, Sweden

\* Correspondent author: hwg@dantecdynamics.com

**Keywords:** Time Resolved PIV, PIV processing, Engine in-cylinder flow, Injection Strategy

## ABSTRACT

The understanding of in-cylinder flow field is one of the keys to realize Partially Premixed Combustion (PPC) for internal combustion engines, which has potential to achieve high combustion efficiency with low soot and NO<sub>x</sub> emissions. In this work, time resolved Particle Image Velocimetry (PIV) was performed to measure the flow field inside the cylinder of a single-cylinder light-duty optical diesel engine.

The engine was modified to Bowditch configuration, and was installed with a quartz piston and a transparent cylinder liner, to allow optical access. The geometry of the quartz piston crown is based on the regular combustion chamber design of mass produced diesel engine, including a re-entrant bowl shape. This causes severe distortion on the obtained images, which has to be handled by a distortion correction method before PIV process.

The in-cylinder flow structures in a vertical plane at the center of cylinder were obtained both within the piston bowl and within the squish volume, during the compression and expansion stroke. Measurements were performed under three different injection strategies as well as motored engine condition. Both the instantaneous flow field from single cycle and ensemble average flow field calculated from 100 cycles at motored engine condition show a well match with previous studies. The results from fired engine conditions show different interaction between injected fuel and in-cylinder air at different Crank Angle Degrees (CADs) with different injection strategies.

All the results in this study can provide a quantitative dataset being useful to model validation of numerical simulation work to investigate PPC engine more.

---

## 1. Introduction

Recently Partially Premixed Combustion (PPC) or Premixed Charge Compression Ignition (PCCI) has been investigated intensively on internal combustion engines, due to its well-known potential for both high combustion efficiency and very low soot as well as NO<sub>x</sub> emissions, to meet the strict emission regulation nowadays [Noehre et al. 2006, Reitz 2013]. One of the key parameters to realize PPC in engines is ignition delay, which is defined as the time difference or the crank angle between start of the final fuel injection and start of combustion (SOC). Ignition delay is influenced by many parameters in engine, such as injection strategies, Exhaust Gas Recirculation (EGR) rate, in-cylinder temperature distribution, etc. Among them, the in-cylinder flow structure play a key role to determine ignition delay, via determining fuel air mixing [Solaka et al. 2013]. Understanding the in-cylinder flow field and then the mixing process is therefore one of the key to realize PPC on engines.

Particle Image Velocimetry (PIV) is a non-intrusive laser diagnostic technique and has been proved to be a mature technique for mapping flow fields. PIV was firstly used to study engine in-cylinder flow in late 1980s [Reuss et al. 1989], and recently receives more and more attention due to the rapid development of digital cameras and advanced PIV process algorithms. Particularly, the recent advancement in the high-speed cameras and diode-pumped solid-state lasers has made it possible to obtain crank-angle-based time resolved 2D or even 3D PIV measurement in engine [Zhao 2012]. This provides the possibility to investigate the large cycle-to-cycle variation and the turbulence of engine flow simultaneously.

Most of the PIV studies on engine either used a flat optical piston geometry or a modified geometry that allows optical access while produces little-to-no distortion of the light emanating from the combustion chamber. Only a few PIV studies have acquired velocity fields in a diesel engine with production-like optical piston, which has a re-entrant, bowl-in-piston geometry [Miles et al. 2006, Colban et al. 2008]. Colban et al. developed a methodology to correct for the optical distortions generated by the curved surfaces of the relatively complex piston geometry and were able to identify the main flow structures in the r-z plane.

To the authors' knowledge, all the PIV studies in an engine with production-like optical piston before 2015 were using a non-time resolved PIV system and performed phase average analysis later based on particle images from a number of cycles. Considering the large cycle-to-cycle variations of internal combustion engine, the flow development derived by this way cannot be very precise due to that the flow field at certain crank angle is obtained from particle images which are acquired from different engine cycles.

One of the limitation of using high speed PIV system for this study is availability of high speed PIV laser with enough power. Thanks to the fast development of high speed PIV laser, Wang and Tanov et al recently started to use a high speed time-resolved PIV system to expand previous work [Wang et al. 2015, Tanov et al, 2015]. They were able to obtain particle images and later individual velocity information of every two crank angle within around 40 engine cycles. They also performed a valuable analysis on the cycle-to-cycle variation and in-cylinder-turbulence based those results.

This work is a further expansion of the study mentioned above. The engine was running at skip-fire mode to achieve more stable boundary conditions. Flow fields of different injection strategies were measured, aiming to investigate more about the influence of different injection strategies on in-cylinder flow.

## 2. Experimental Setup

### 2.1 Engine Facilities

The experiments were performed in a Bowditch-designed single-cylinder engine modified from a Volvo D5 light duty diesel engine. Table 1 shows its specification. A schematic of the optically accessible engine, including a production-like optical piston and an optical cylinder liner with height of 3 cm, is shown in Fig. 1. The same figure also shows a geometrically accurate representation of the piston bowl, which has a maximum internal radius of 25.1 mm, a bowl rim radius of 22.6 mm, and a maximum depth of 14.8 mm. Due to the large top ring-land crevice required for side-view imaging, the geometric compression ratio of this optical engine is lower than the target of 16, typical of PPC combustion systems. The engine further allows the intake swirl to be adjusted by a swirl control valve and was operated at a swirl ratio of 2.6 through this work. A Bosch common rail fuel injection system and a 5-hole solenoid Bosch injector were used for fuel injection.

**Table 1** Engine geometry and fuel injection specifications

Engine Base Type	Volvo D5
Number of cylinders	5
Number of valves	4, two for intake, two for exhaust
Bore (mm)	81
Stroke (mm)	92.3
Displacement (L)	0.48

Compression ratio (original metal configuration)	16:1
Compression ratio (optical configuration)	11.3:1
Swirl ratio	2.6

### Fuel Injection

Type	Common Rail
Fuel-injection type	Solenoid
Hydraulic flow rate	360 cc/30s @100bar
Umbrella angle	140°
Orifice diameter (mm)	0.159
Number of holes	5

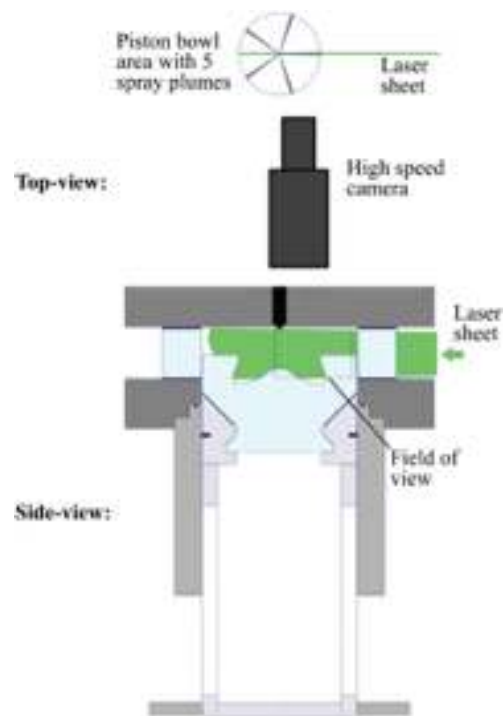


Fig. 1 Schematic of optical engine and PIV setup

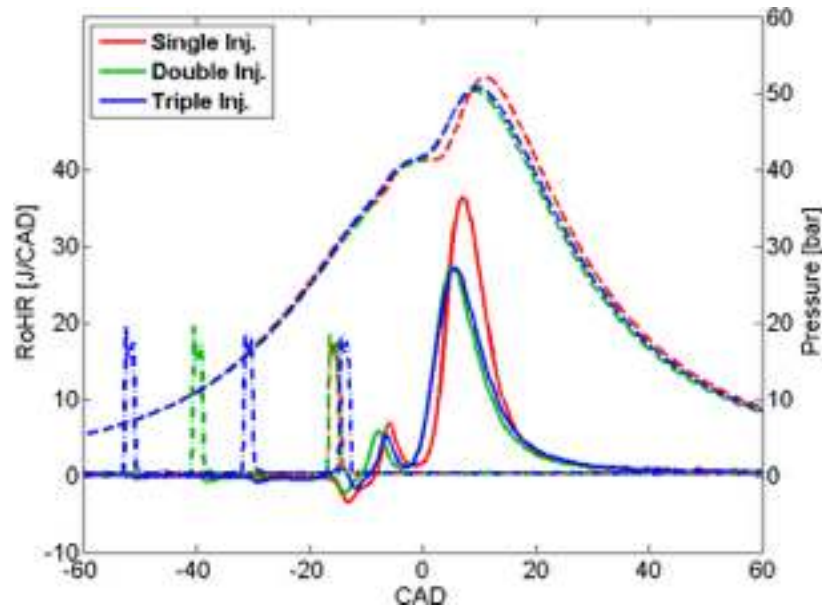
## 2.2 Operation Conditions

Through this study, the engine was running at 800 rpm, with an injection pressure of 850 bar. A blended fuel, PRF 70, consisting of 30% n-heptane and 70% iso-octane in volume percentage was used in the experiment to achieve suitable ignition delay prior auto-ignition for PPC. Injection strategy was the main variable for the comparison and three different injection strategies (single,

double and triple injection) were tested. Combustion phasing (CA50, which means crank angle for 50% total heat release after the ignition) was kept constant at  $8 \pm 0.5$  Crank Angle Degree (CAD) after Top Dead Center (TDC). At SOC the fuel/air mixture was stratified to achieve stable ignition and controlled heat release. The intake air temperature was kept at 40 °C and the intake air pressure was 1.2 bar. Additional operating conditions are summarized in Table 2. Heat release rate and pressure traces for different conditions are shown in Fig. 2.

**Table 2** Engine operation conditions

<b>Engine operation parameters</b>			
Intake pressure (bar)		1.2	
Intake temperature (°C)		40	
Injection pressure (bar)		850 $\pm$ 2	
Fuel mass for single injection (mg)		12.4	
O <sub>2</sub> (vol %)		21	
Cooling water temperature (°C)		65 $\pm$ 2	
Liner temperature (°C)		80	
Fuel type		PRF 70	
<b>Injection timing</b>		SOI (CAD)	Duration per Injection (CAD)
Case A	Single	16	2.5
Case B	Double	40/16	1.9
Case C	Triple	55/30/18.5	1.7/1.7/2



**Fig. 2** Heat release rates (solid line) and pressure (dash line) at constant combustion phasing ( $CA_{50} = 8$  CAD after TDC)

The engine was only fired once every four cycles to minimize thermal and mechanical loading of the optical components and to maintain the thermal boundary conditions of the combustion chamber.

### 2.3 PIV Measurement system

An Nd: YLF diode pumped dual cavity laser (model type: DualPower 30-1000), was used here as the light source. Its wavelength is 527nm and it can reach maximum 30mJ energy per pulse at a repetition rate of 1 kHz. In the case of engine running at 800rpm, the laser shoots at 4.8 kHz, with 10mJ energy per pulse, to provide one pair of illumination per crank angle. A light sheet optics unit was used to generate a diverging light sheet. The light sheet was passing through the injector tip, and focused in the area between injector tip and liner inner surface in the thickness-wise view. The light sheet had a height around 3 cm through the field of view.

Titanium Dioxide ( $TiO_2$ ) powder was used as PIV seeding particles, which have a mean particle diameter from 2 to 3  $\mu m$  and a density of 4260  $kg/m^3$ . Assuming Stokes drag, the particle time constant ( $\tau_s$ ) – representing the response time to changes in the flow – is roughly 40  $\mu s$  at TDC-like thermodynamic conditions. At these conditions,  $\tau_s$  is slightly larger than the estimated Kolmogorov time scale and thus the seeding particles can follow most of the turbulent structures. Seeding particles were introduced from a cylindrical container fed by a swirl airflow of around 20 liters/min, which was precisely controlled by a mass flow meter. The seeding flow was then mixed with the intake stream inside the intake manifold. The  $TiO_2$  powder was baked over 24 hours before seeding into the engine, to prevent the particles agglomeration efficiently. In

addition, water vapor was added to the intake stream, as part of EGR gases, to reduce the electrostatic charge build-up, and eventually to reduce the chance of having the particles adhere to the optics of the engine. These two procedures were proved to be essential for in-cylinder PIV measurement in the optical engines.

Images were acquired in double shutter mode using a high speed CMOS camera (SpeedSense 710). The image format was cropped to  $1040 \times 440$  pixel to increase the maximum camera frame rate. The exposure time for all image pairs was  $63 \mu\text{s}$  for the first frame and around  $142 \mu\text{s}$  for the second frame. The long exposure for the second image was due to the time required to readout the first image from camera sensor. The time between the laser pulses was set to  $15 \mu\text{s}$ , which is a good compromise between resolving velocities and being able to perform the cross-correlation. A synchronization system was used to synchronize the engine rotation and PIV image acquisition system so one image pair can be obtained every crank angle degree.

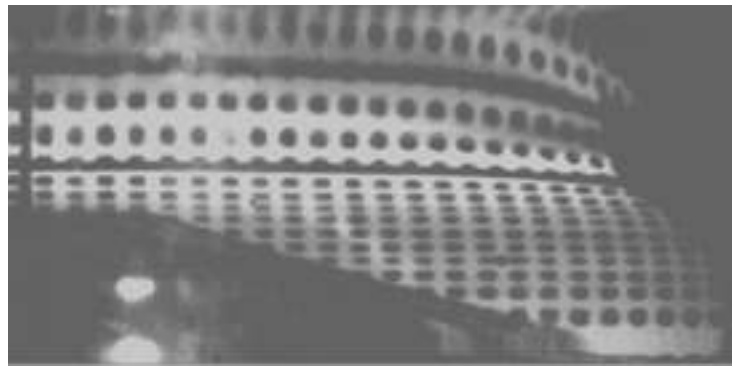
The optical piston with a similar bowl geometry with a realistic one would bring significant optical distortion to the acquired image. Considering the piston glass has irregular thickness in the optical path, thus distortion is impossible to be compensated by adding additional optics between the engine and the camera; and so far it can be only handled by software image dewarping. A Nikkor 105 mm lens with an extension ring of 13mm was used here and the lens aperture was closed as much as possible ( $f\# 16$ ) to obtain focus in the full field of view. With this imaging system, the resulted spatial resolution is around  $25 \mu\text{m}/\text{pixel}$ .

No filter was used in this measurement, since it was proved that there was little soot luminosity from PPC combustion thus the Mie scattering light from particles was always dominant here.

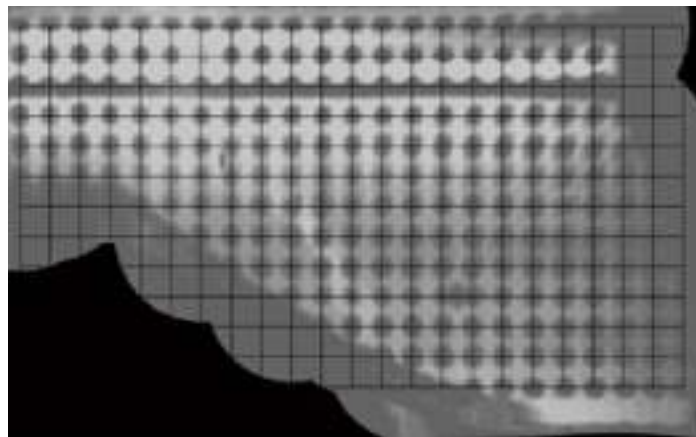
#### **2.4 Image distortion correction**

Using a production-like re-entrant optical piston resulted in severe image distortion. This can be minimized through recording a reference targets and determining a transformation matrix, which is later applied on particle images to correct its distortion. Fig. 3 shows the reference target image with distortion and after distortion correction. In this study, a dot target was used, which has uniform located dot markers ( $1\text{mm} \times 1\text{mm}$ ) on its surface.





(a)



(b)

**Fig. 3** Dot target image: (a) raw image before distortion correction; (b) after distortion correction

## 2.5 PIV evaluation

Velocity vectors were computed on the distortion corrected image pairs using Adaptive PIV, a commercial PIV processing software provided by Dantec Dynamics. This method allows the interrogation area (IA)—based on which the cross correlation is computed—to iteratively adapt its size, shape, as well as orientation in order to improve the calculated vector accuracy in the end. In this study, the IA size was selected to start with  $32 \times 32$ ; it can go down to  $8 \times 8$  during iteration if necessary.

Once the raw vector maps had been computed, a moving average algorithm was first applied to the raw individual vector field to remove outlier vectors. The filter size was  $3 \times 3$  vectors. With this method, each vector was replaced by the median value of the surrounding eight neighbors. The vector maps after applied with moving average were used for further analysis.

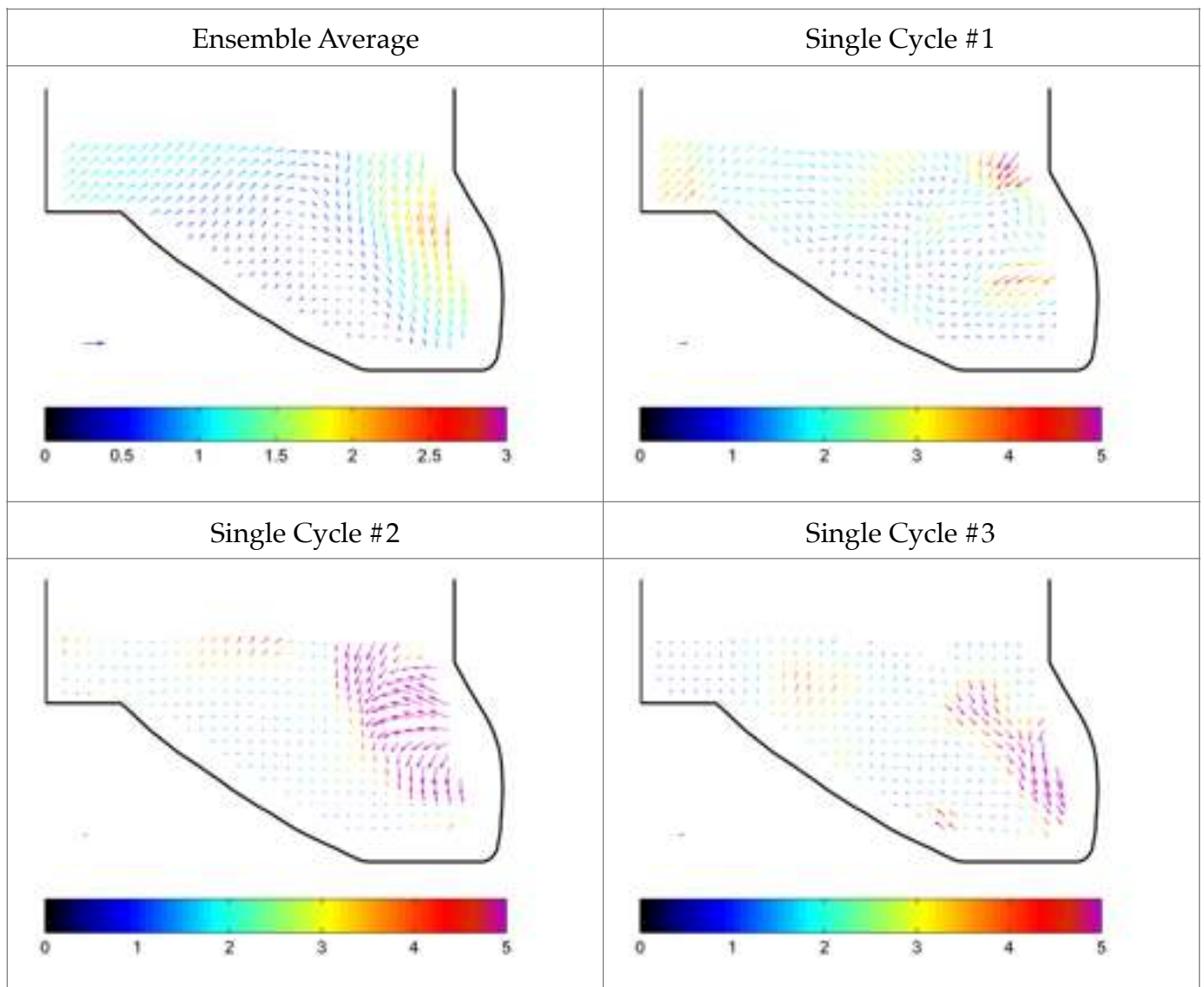
## 3. Results and Analysis

### 3.1 Motored condition

The PIV results from engine motored condition are first presented and analyzed here to validate this measurement, since the flow field at this point is well studied. Fig. 4 shows the velocity fields at TDC while the engine was motored at 800 rpm. Both instantaneous flow fields from three consecutive cycles and ensemble average velocity field from 140 consecutive cycles are presented here. The ensemble average velocity is defined as:

$$\bar{U}_{EA}(\theta) = \frac{1}{N} \sum_{i=1}^N U(\theta, i) \quad (1)$$

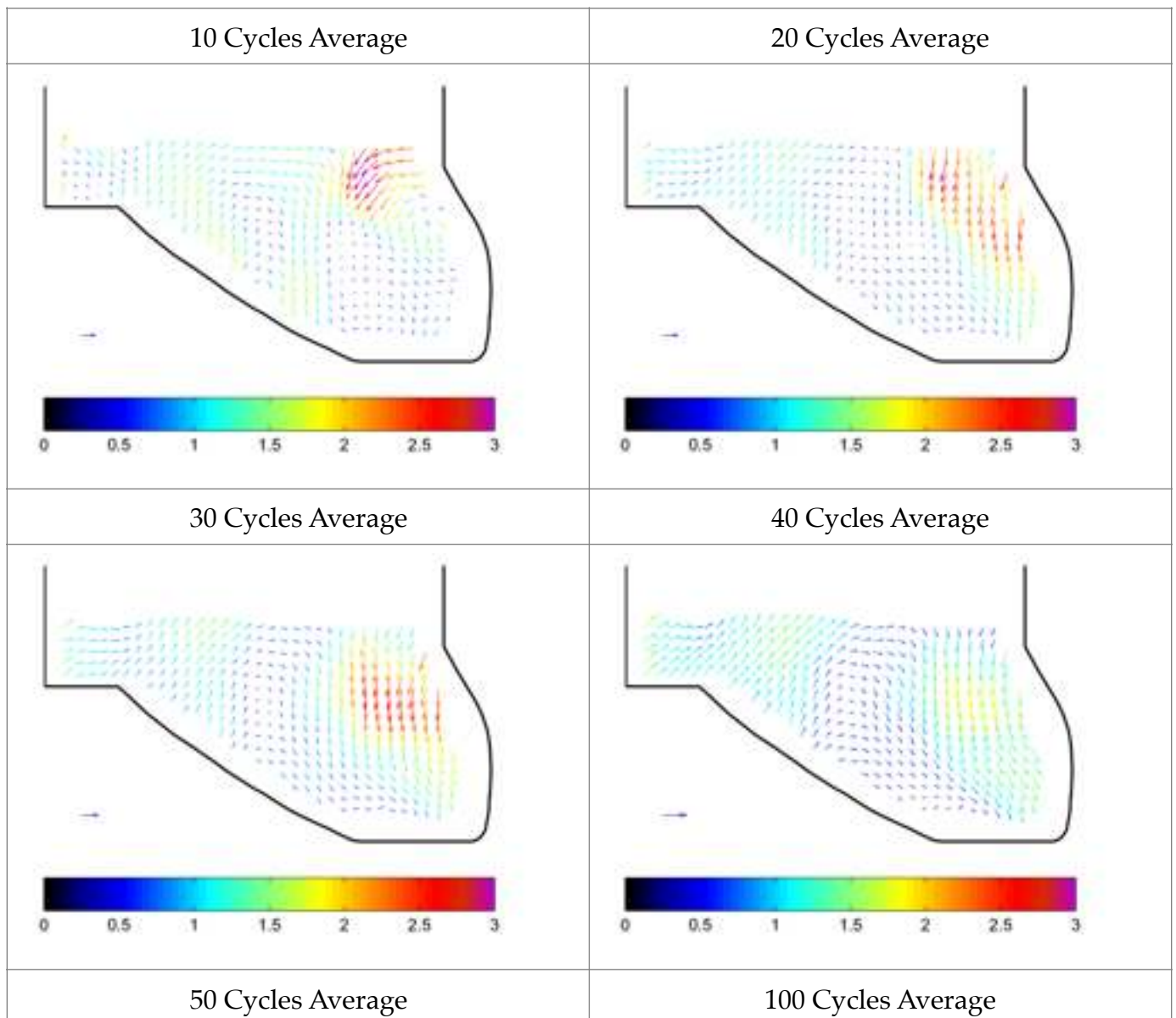
Where  $U$  means instantaneous velocity,  $\theta$  indicates the CAD,  $i$  is the cycle index and  $N$  is the number of cycles used to calculate ensemble average velocity.

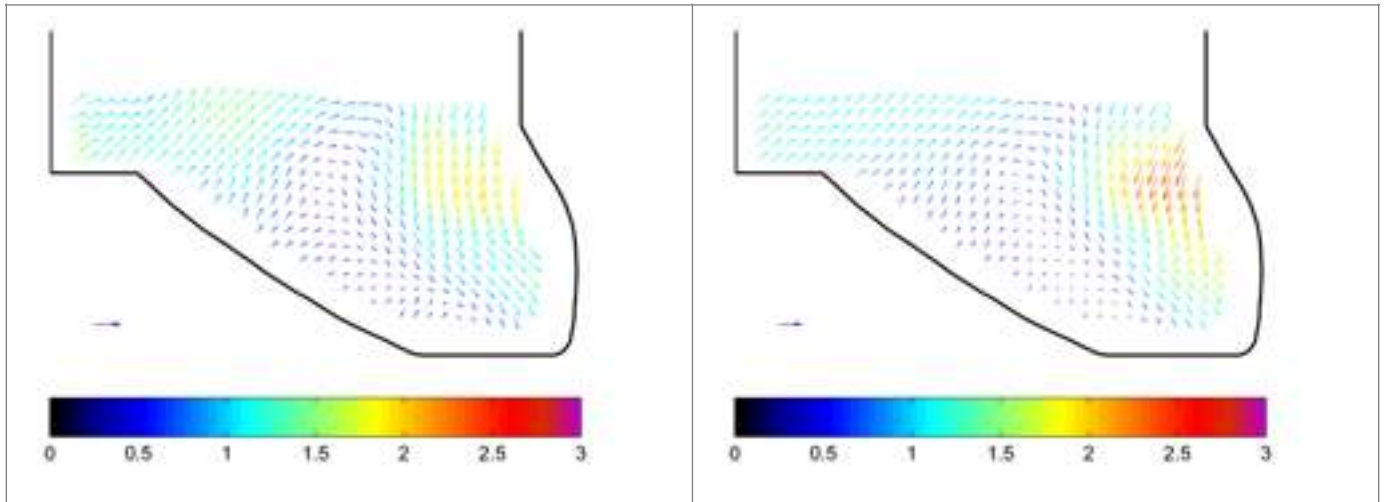


**Fig. 4** Velocity field at TDC, 800 rpm motored condition (Reference vector: 2m/s)

Significant cycle to cycle variation can be observed here. Nonetheless, the mean field flow structure can still be seen in most of instantaneous flow fields of single cycles. The center of piston bowl pushed the flow upward, which met the roof of combustion chamber and bounced back to the piston bowl. This forms a clockwise rotation structure. This structure has been also observed by several previous studies [Colban et al. 2008, Wang et al. 2015].

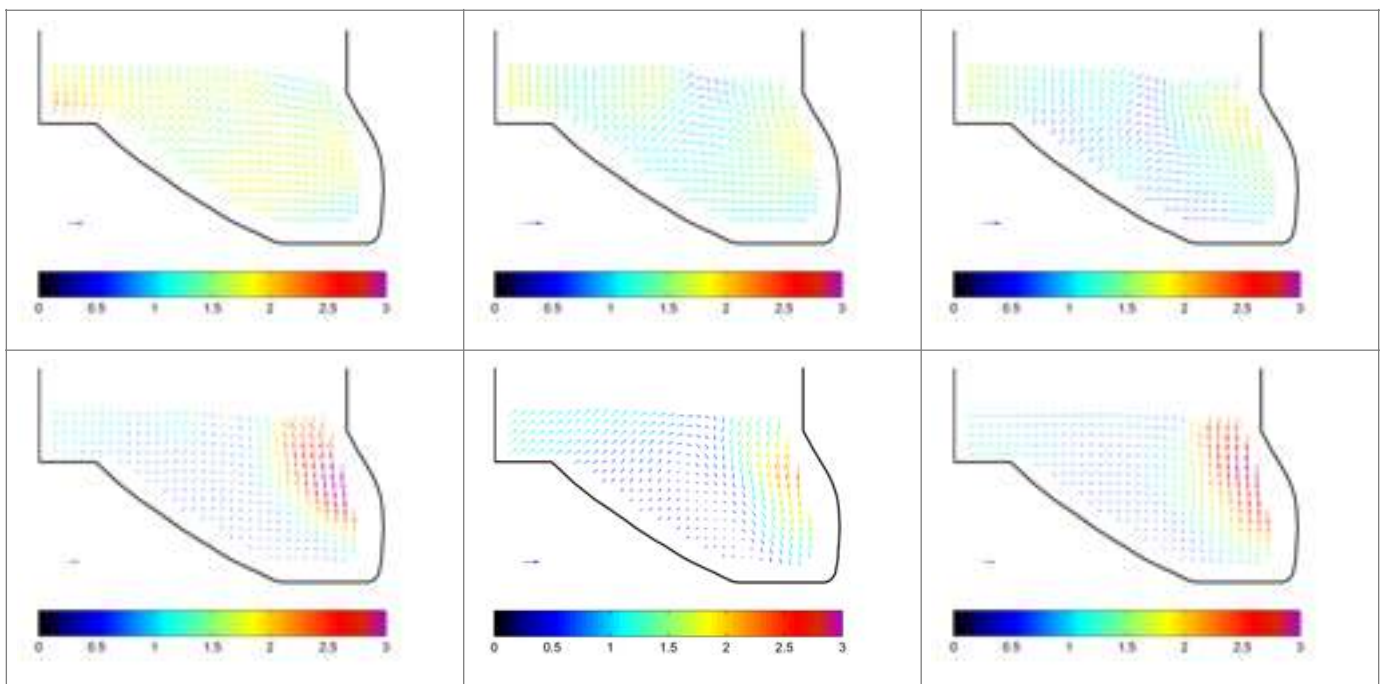
Fig. 5 shows the ensemble average velocity fields averaged over 10, 20, 30, 40, 50 and 100 cycles to illustrate the progression of mean field convergence. The ensemble average vector field converges quickly, showing almost no change beyond a 30-cycles average.





**Fig. 5** Ensemble velocity field over different numbers of cycles to show convergence, at TDC, motored condition  
(Reference vector: 2m/s)

Fig. 6 shows the ensemble average flow field development of motored condition inside the piston bowl from 20 CAD before TDC (BTDC) to 20 CAD after TDC (ATDC). Before and at 20CAD BTDC, the in-cylinder flow is mainly driven by the piston motion. Later as the piston moving closer to the cylinder roof, more and more flow is compressed by the cylinder roof, and eventually forms a rotation structure at TDC due to the re-entrant piston bowl shape. After TDC, as the piston moving down, the in-cylinder flow start to expand and the bulk flow is following the piston bowl downwards. Similar structure has been observed and discussed in detail by previous studies [Colban et al. 2008, Wang et al. 2015, and Tanov et al. 2015].



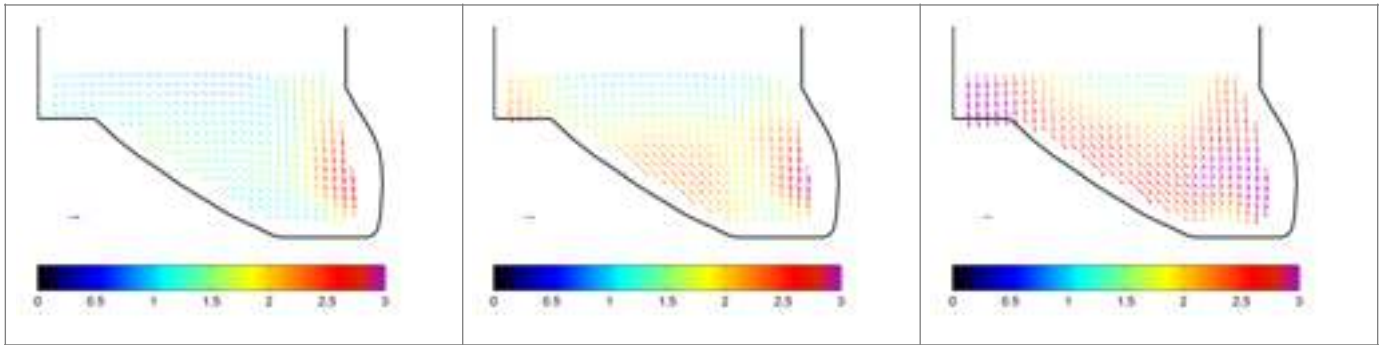


Fig. 6 Ensemble average flow development inside the piston bowl, motored condition

### 3.2 Fired condition

Fig. 7-9 shows the ensemble average flow development of three fired conditions with different injection strategy. At single injection condition, the flow field development was the same as motor condition before the start of injection (16CAD BTDC). Soon after start of injection (15CAD BTDC), high speed spray entered the piston bowl and dominated the in-bowl flow field. Later the fuel impacted the inner wall of piston bowl and formed a small vortex at the right hand of the impact area. This clockwise vortex was pushed upwards by the upward bulk flow until TDC, when combustion took place. After TDC, the flow started a complex development due to both expansion of combustion chamber and combustion event. The main flow was moving downwards, driven by the expansion of combustion chamber. Meanwhile a counter rotate vortex structure was observed until 20 CAD after TDC (ATDC), when the combustion finished. This structure also helped to bring the flow to the squish region. In order to understand this structure, information of the third velocity component (out of plane velocity) is needed.



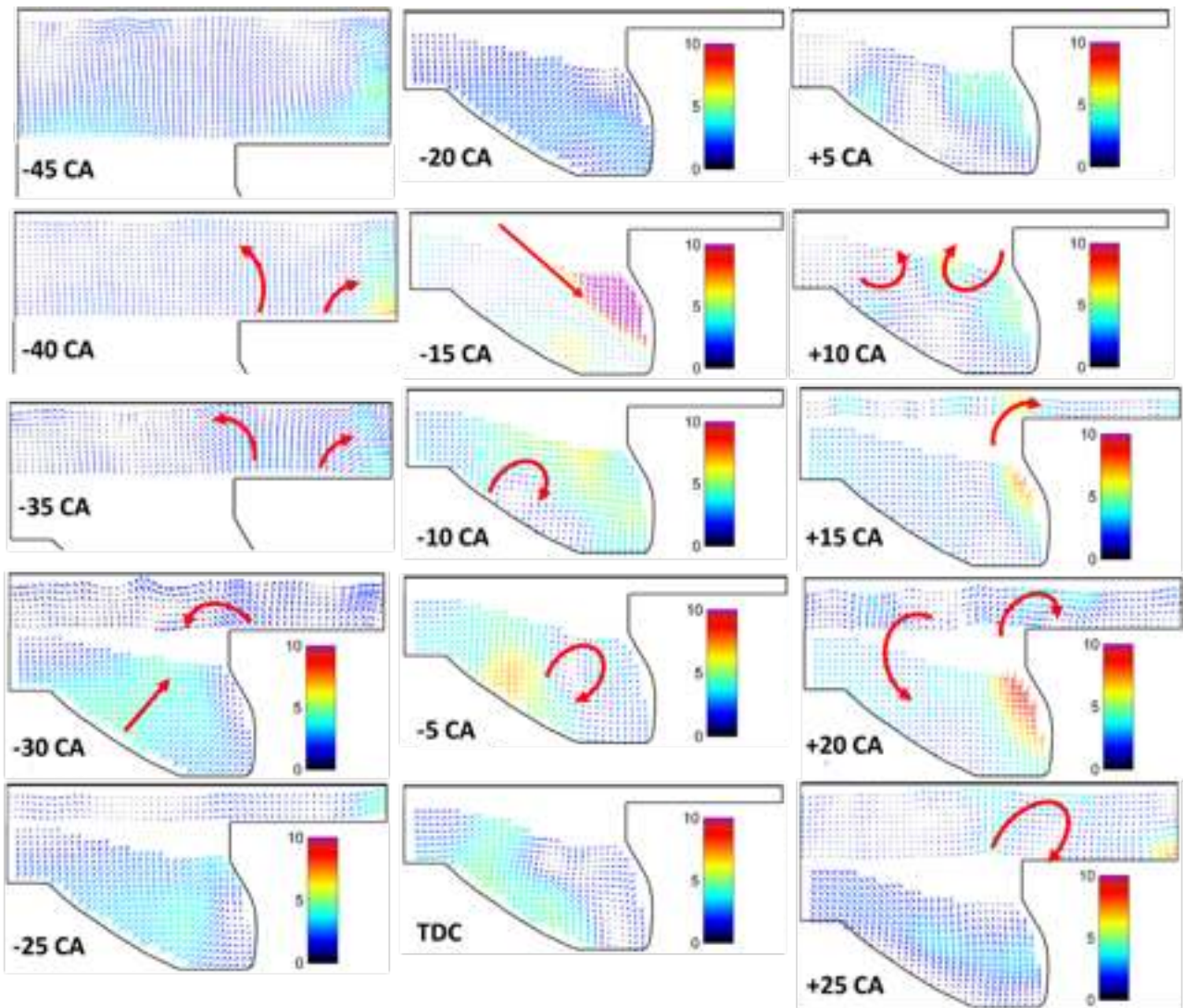


Fig. 7 Ensemble average flow development, single injection

In case of double injection, the in-cylinder flow was first influenced by the first injection at 40 BTDC. At this point, the piston was still relatively far from the cylinder roof and thus the in-bowl flow was not influenced by the injected fuel yet. However, the fuel injection accelerated the flow motion. It seems the upward bulk flow pushed the small amount of injected fuel away from center of cylinder. After the second injection, the flow field had the similar developing pattern as single injection condition. Due to double fuel injection, the amount of fuel injected at 16 CAD BTDC was less compared with single injection, and thus the in-bowl flow was less influenced by the injected fuel.

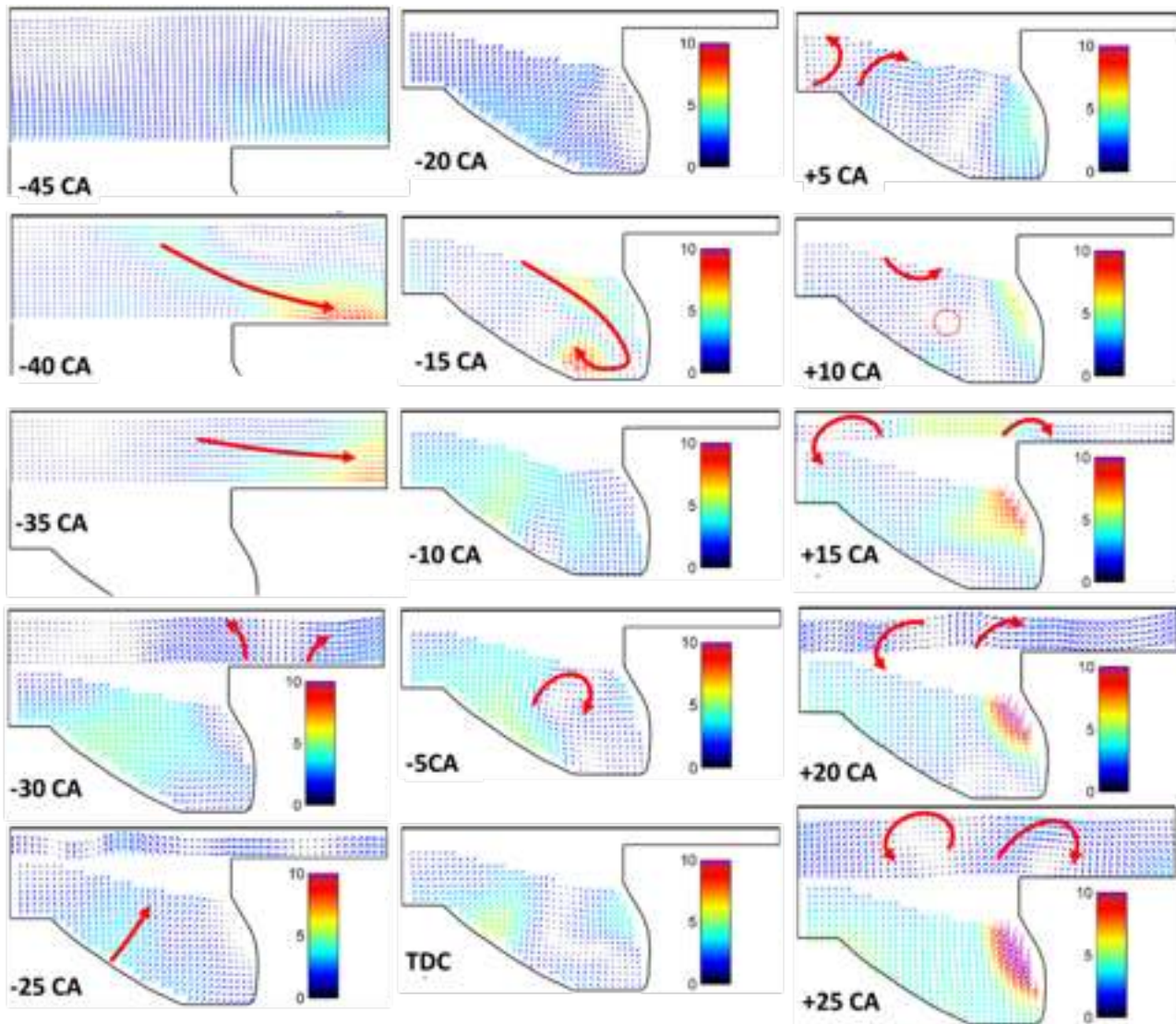


Fig. 8 Ensemble average flow development, double injection

In case of triple injection, the injection of same amount of fuel was split to three times. As a result, the bulk flow before combustion was much less influenced by the injection events. The big vectors observed near the cylinder liner of squish region from 45 to 30 CAD BTDC are questionable, which might due to bad illumination condition. In this region, light sheet is strongly diffused and the background is much brighter than other area. Thus the noise level is much higher and the results are questionable here.

At 15 CAD BTDC, the sign of injection can be still observed. The injected fuel firstly hit the piston bowl and then rebounded, rolled up the surrounded air-fuel mixture and formed a vortex eventually. The flow structure of this case is very similar as the one with double injection. This is also reflected from the heat release rate profile (Fig. 2): the heat release rate profiles of double injection and triple injection are almost overlapped after TDC. In another similar study [Wang et



al. 2015, Tanov et al. 2015] had similar observation. They also analyzed the turbulence and claimed that the turbulence would increase if injection is split.

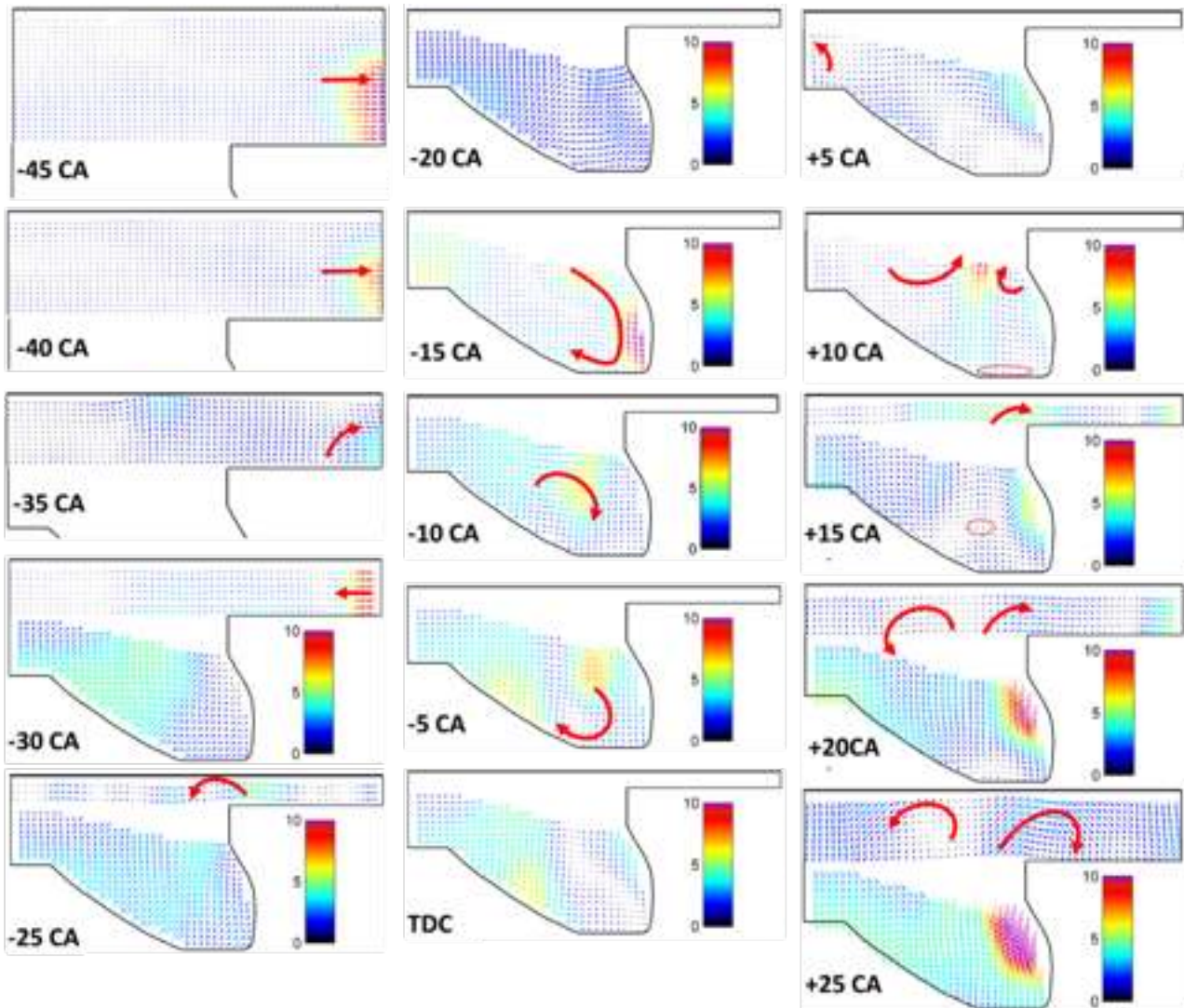


Fig. 9 Ensemble average flow development, triple injection

#### 4. Conclusion

A time-resolved PIV measurement was successfully performed on a light duty optical engine with a re-entrant piston bowl shape, under several different conditions. The re-entrant piston bowl shape brings the measurement results closer to reality, while causing severe image distortion, which must be handled carefully during PIV evaluation.

Both ensemble average flow field based on many cycles and instantaneous flow field from single cycles were obtained in this study. Both of them are analyzed for motored condition, which shows a good agreement with previous studies.



The crank angle development of ensemble average flow field resulted from three injection strategies are compared here. All results indicate the interaction between injected fuel and the air inside the piston bowl, which forms a vortex there. The more times of injection, the less influence is observed to the bulk flow. It is also found that combustion created a counter-rotate vortex structure.

The results generated in this study provides an experimental database, and will be used to validate a parallel simulation study of such PPC engine.

## Reference

- Colban W, Ekoto I, Kim D, and Miles P C (2008) In-Cylinder PIV Measurements in an Optical Light-Duty Diesel at LTC Conditions. Conference on Thermo-and fluid Dynamic Processes in Diesel Engines, Valencia, Spain, 2008
- Miles PC, Hildingsson L, and Hultqvist A (2006) The Influence of Fuel Injection and Heat Release on Bulk Flow Structures in a Direct-Injection, Swirl-Supported Diesel Engine. 13th Symposium on Applications of Laser Techniques to Fluid Mechanics, Lisbon, Portugal, 2006
- Noehre C, Andersson M, Johansson B, and Hultqvist A (2006), Characterization of Partially Premixed Combustion. SAE Technical Paper 2006-01-3412
- Reitz R (2013) Directions in internal combustion engine research. Combustion and Flame 160, no. 1 (2013): 1-8.
- Reuss D, Adrian R, Landreth C, French D et al (1989) Instantaneous Planar Measurements of Velocity and Large-Scale Vorticity and Strain Rate in an Engine Using Particle-Image Velocimetry. SAE Technical Paper 890616
- Solaka H, Tuner M, and Johansson B (2013) Analysis of Surrogate Fuels Effect on Ignition Delay and Low Temperature Reaction during Partially Premixed Combustion. SAE Technical Paper 2013-01-0903
- Tanov ., Wang Z, Wang H, Richter M et al. (2015) Effects of Injection Strategies on Fluid Flow and Turbulence in Partially Premixed Combustion (PPC) in a Light Duty Engine. SAE Technical Paper 2015-24-2455, 2015, doi:10.4271/2015-24-2455.
- Wang Z, Tanov S, Wang H, Richter M, Johansson B and Alden M (2015) Partially Premixed Combustion (PPC) in a Light Duty Engine for Different Injection Strategies. SAE Technical Paper 2015-24-2454 doi:10.4271/2015-24-2454

- Zhao H (2012) Laser Diagnostics and Optical Measurement Techniques. SAE International, U.S.A.

### **Acknowledgments**

This research was performed at Lund University. The authors would like to acknowledge the Swedish Energy Agency and KCFP (Grant number 22485-2) for financial support. The research leading to these results has also received funding from the People Programme (Marie Curie Actions) of the European Union's Seventh Framework Programme FP7/2007-2013/ under REA grant agreement number 607214.