

# Tiny Web Services: Design and Implementation of Interoperable and Evolvable Sensor Networks

Nissanka B. Priyantha, Aman Kansal, Michel Goraczko, and Feng Zhao  
Microsoft Research

{bodhip, kansal, michelg, zhao}@microsoft.com

## ABSTRACT

We present a web service based approach to enable an evolutionary sensor network system where additional sensor nodes may be added after the initial deployment. The functionality and data provided by the new nodes is exposed in a structured manner, so that multiple applications may access them. The result is a highly inter-operable system where multiple applications can share a common evolving sensor substrate. A key challenge in using web services on resource constrained sensor nodes is the energy and bandwidth overhead of the structured data formats used in web services. Our work provides a detailed evaluation of the overheads and presents an implementation on a representative sensor platform with 48k of ROM, 10k of RAM and a 802.15.4 radio. We identify design choices that optimize the web service operation on resource constrained sensor nodes, including support for low latency messaging and sleep modes, quantifying trade-offs between the design generality and resource efficiency. We also prototyped an example application, for home energy management, demonstrating how evolutionary sensor networks can be supported with our approach.

## Categories and Subject Descriptors

C.2.4 [Computer Systems Organization]: Computer Communication Networks—*Distributed Systems*; J.7 [Computer Applications]: Computers in Other Systems

## General Terms

Measurement, Performance

## Keywords

web services, TCP/IP, battery life

## 1. INTRODUCTION

As sensor networks move from labs to long-running real-world deployments, a major problem we are facing is the difficulty in augmenting and evolving an existing sensing infrastructure over time, with additional hardware and software capabilities. Such evolutionary sensor networks are representative of a broad class of applications

where heterogeneous sensors are deployed for multiple co-existing sensing tasks within a single confined physical space such as an office, home, or warehouse. Consider as an example a home energy usage monitoring and control system. In the US, residential energy usage is a significant fraction of the total energy consumed. In 2001, for instance, the 107 million US homes consumed 21.86 Quadrillion ( $10^{15}$ ) Btu of energy costing USD 157.5 billion [18]. Efforts such as energy efficient construction and energy saving appliances [12] are underway, and many believe that better visibility into how energy is delivered and consumed in homes will be a key towards enabling further energy savings. Sensor networks can play a significant role, for example, in optimizing home energy consumption in response to the activity state of the occupants.

The home energy management application can be more cost-effective when allowed to use a sensor network deployed in an evolutionary manner. The home may have pre-existing wireless sensors deployed for a security application based on intrusion sensors on doors and windows, and motion detection sensors in indoor areas near the perimeter. The home may also have a temperature sensor used to control a cooling or heating system. At a later time, more motion or activity sensors may be added to the home in other indoor areas for monitoring the activity of a senior resident (such as for detecting disruptions to normal routine). The home energy management application can use many of these sensors to detect home occupancy and user activity. In addition to using the existing sensors, it may add new sensors to the deployment for measuring, visualizing, and controlling power usage.

In many existing sensor network usage scenarios, each application deploys its dedicated set of sensors. Each node is programmed with a sensor data collection, event detection, or query processing capability and sends its data (sensor readings, events, query responses) to its user application using custom protocols and message formats [20, 27]. This mode of usage is not well suited for situations where sensor nodes with different protocols, say from different manufacturers, may be added to a sensor deployment over time. The custom protocols, new data types, and new functionality of the new nodes may not be exposed by the gateway. Adding new end-user applications to the existing deployment becomes difficult due to lack of direct access to sensor capabilities. An alternative will be to support the evolution of a sensing system and hardware with a common, well-understood application-level interface, so that all deployed sensors are available to all applications (Figure 1). As new sensors are added for new applications, existing applications may also benefit from the added sensors. Certain new applications that may not be cost effective to deploy with dedicated sensors may become feasible.

Permission to make digital or hard copies of all or part of this work for personal or classroom use is granted without fee provided that copies are not made or distributed for profit or commercial advantage and that copies bear this notice and the full citation on the first page. To copy otherwise, to republish, to post on servers or to redistribute to lists, requires prior specific permission and/or a fee.

SenSys'08, November 5–7, 2008, Raleigh, North Carolina, USA.

Copyright 2008 ACM 978-1-59593-990-6/08/11 ...\$5.00.

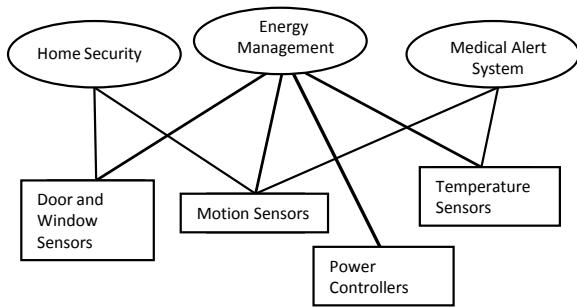

**Figure 1: An example of evolutionary sensor network with sensors shared by multiple applications.**

To support such system evolution, two fundamental features are needed:

**Structured data:** The first is that the data generated by the sensor nodes be represented in a structured format that any application may understand. For instance, data objects represented in XML may be read by any application while a custom bit representation requires a detailed documentation to interpret.

**Programmatic description of functionality:** The second feature is that the functionality of a sensor node be understood programmatically. While a new sensor node added may automatically connect to the network using say DHCP and related methods, an application cannot use it until the functionality of the device is known. Programmatic access to sensor node functionality may allow a new user application to discover all sensors it may use or even allow existing application to add features as new sensor nodes are deployed.

As an added advantage, this could make end-user application development less prone to bugs since most of the message formats and packet exchanges can be programmatically and automatically generated from the programmatic description rather than by manually reading the documentation for required bit sequences and message protocols for each custom gateway device format.

The above capabilities already exist for Internet connected devices and are available through web services: web method calls allow structured data objects to be exchanged with remote resources and the web service description enables programmatic ways to express the device functionality. The key **challenge** we must address in using such an approach for sensor networks is the minimization of resource cost for providing structured data formats and functionality descriptions at the sensor nodes. These resource costs are negligible for wired nodes. However, for low-power wireless sensor nodes that run for years without battery replacement, all resources including bandwidth, processor capability, and the active duty cycle are very limited. In this case, it is not obvious if the additional data size and processing costs for such structured access can be supported.

The **goal** of this research is to quantify the resource costs of providing structured and programmatic access to sensor nodes using web services, and to identify design options that minimize these costs and trade-offs between interface generality and resource efficiency. We characterize the costs of using web services in sensor networks, and describe our design choices for making these costs acceptable on a resource constrained wireless device. To support ease of programming, our design choices maintain compatibility with commonly used web service development tools.

To constrain our design exploration and implementation, we use

a prototype sensor node that we built using an MSP430 processor and an IEEE 802.15.4 radio (Figure 2). The processor runs at 6Mhz, contains 48k of ROM, and operates at power levels typical of many low-power sensor nodes designed for multi-year lifetimes. The radio provides a maximum raw data rate of 250kbps. We im-

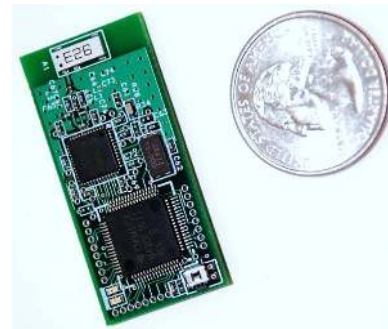

**Figure 2: The wireless sensor platform, with an MSP430 processor and 802.15.4 radio, for carrying out the experiments reported in the paper.**

plement web services on the above low-power platform, using only 15.8kB of ROM space. The energy and latency overheads compared to sending the raw data in 802.15.4 packets are very small: the battery lifetime is reduced by less than 11% and the latency increase is only 23.09ms when transmitting a 40 byte message every 10 minutes.

Our research yields several important guidelines for efficient use of TCP/IP and web services on sensor networks, including the use of persistent TCP connections, disabling delayed acknowledgments in TCP, and using link layer retransmissions. While traditional web service usage assumes that the server hosting the service is always on, we show how web services can be hosted in an energy efficient manner on duty cycled nodes that must enter a low power disconnected state for long periods of time. We further discuss the proper choice of web service bindings and XML decoding for efficient implementation on sensors with very limited memory.

We use the home energy application to provide realistic requirements and application constraints for an evolutionary sensor network, such as to obtain sample message types required, events generated, sampling rates, and other system constraints. Further, to test the application, we built prototype power sensor nodes that measure the energy used by an appliance (for up to 2kW) plugged into our sensor node. The sensor node doubles as an actuator and can turn the power to the appliance on or off as well, similar to the system in [19]. As a test case, we deployed the power sensor-actuator nodes in a home with wireless motion sensors and perimeter intrusion sensors for a period of 12 days. Sample sensor traces from the deployment are shown in Figure 13. Using the sensor data, a simple occupancy-based optimization algorithm was able to achieve a 7.2% saving in home energy usage. More details of the case study are in Section 6.2.

The **contributions** of the paper are threefold:

1. Characterize the energy costs of various overheads associated with using web services,
2. Enumerate the design options available and the associated trade-offs in implementing web services, indicating the most suitable choices for sensor nodes, and
3. Present our implementation of the web service approach using only 15.8kB of ROM and < 1kB of RAM.

While the home energy application is used as a concrete test case for this research, the device resource constraints for the sensor nodes used are representative of many other wireless sensor network deployments and our design is thus relevant to more general systems.

The rest of the paper is organized as follows. Section 2 discusses related work. Section 3 discusses the relevance of web services to sensor networks. Section 4 discusses our design space explorations to optimize the operation of web services on resource-constrained sensor nodes. Section 5 presents the experimentally measured energy and latency overheads of the proposed approach. Section 6 describes our prototype implementation, including our power sensor node, and the test deployment of the home energy management application. We discuss the objectives achieved by our design and some of the key open issues in Section 7.

## 2. RELATED WORK

The use of XML-based structured data has previously been explored in sensor networks in IRISnet [9]. However, XML was used to represent a logical view of the data available across multiple sensor nodes rather than to expose sensor node functionality via web services. The implementation was focused on gateways and non-resource constrained sensor nodes such as video cameras. Our work focuses on the low-power sensor nodes and uses XML to support web services, enabling a very different set of features compared to [9]. Another effort, SensorML [29], provides descriptions of sensor systems using XML, focusing on the data formats and functions for a wide range of sensors. Our focus is on providing structured data and programmatic access to functionality on resource-constrained nodes.

Web services have been prototyped on embedded systems [16, 17], though for devices with more resources than the low-power sensor nodes. The code size and memory footprints achieved there are an order of magnitude larger than the ones in our system. We discuss the key design trade-offs in achieving a reduced overhead implementation.

Another related web service implementation for devices is provided in SOCRADES [8], a middleware architecture for building production processes on top of Devices Profile for Web Services (DPWS) enabled smart objects. Due the limitations of device capability, DPWS is implemented on gateway devices. We implement web services directly on resource-constrained devices using the Web Services Description Language (WSDL) [6] specification, eliminating the need for application layer gateways that may get tied to a custom format between the gateways and sensor nodes hampering evolvability.

Another closely related work is the support for network layer interoperability using TCP/IP in sensor nodes [10, 11]. Our paper focuses on the application layer interfaces provided through web services, and assumes that the network layer interoperability, using the TCP/IP implementation from [10], is already available. We use IPv4 in our evaluation of network layer overheads and resource costs for web services. A newer version, IPv6, is now widely supported and is expected to have greater overheads in terms of the number of bytes transferred and resultant number of packets. However, efforts such as 6lowpan [21] provide methods to reduce those overheads. An implementation of 6lowpan for low power sensor networks is available [1].

Web services have also been built using UDP [7] instead of TCP, using SOAP encapsulation. However, UDP does not provide end-to-end reliability and in order to avoid re-inventing TCP like functionality at the application layer, our design uses TCP.

In hosting web services on power-constrained sensor nodes, we include support for sleep modes and duty cycled operation through

the use of event notifications. The use of events has been proposed for web services through the WS-Eventing [28] specification. We keep our design compatible with [28] to enable easy integration with web service based Internet applications.

We also explore the design advantages of compressing the XML-based structured data formats used in web services in order to reduce their bandwidth and energy overheads. XML compression has been considered before [5, 2]. The compression ratios for several XML compression schemes are compared in [2] but most of those methods are not suitable for implementation on low-power sensor nodes. We discuss the relevance of such XML compression to low-power sensor nodes in Section 4.5.

Standards such as ZigBee<sup>1</sup> [30], Zwave, X10, and Echelon may also support interoperability of low-power devices. However, each of these standards is tied to a single physical layer standard and, these standards need application layer gateways to connect to the rest of the Internet. We focus on an alternative approach that is built on widely-used open standards such as TCP/IP and web services. The TCP/IP layer enables any two devices with IP-compatible physical layers to communicate; while the web services layer enables an application to access resource-constrained devices using the same tools that are used for accessing other online services hosted on more powerful servers, without the need for application-layer gateways. We do not aim to provide an exhaustive comparison between our approach and other standards that enable device interoperability; rather, we provide an evaluation point that helps compare a web services-based solution to other standards.

## 3. WEB SERVICES FOR SENSORNETS

To explain the relevance of web services for sensor networks, we briefly summarize the capabilities of web services and show their advantages for sensor networks.

### 3.1 Structured data and functionality

Web services provide a mechanism for distributed applications to use resources that are on remote devices in a manner similar to local resources. A typical usage scenario is that some functionality available on one server is exposed as a method call for applications running on remote devices. The web service protocol stack internally creates and exchanges the appropriate network messages required for the call, and provides the returned data object to the calling application. The programmer does not have to be concerned with the network protocols, packet formats, or other low-level details of the underlying network. For example, a weather server may provide a method to obtain temperature: `Float temperature = GetTemperature(string Location)` and any application, running on an Internet connected device, can call this method.

To realize the above functionality, web services standards specify two key components: *ports* and *bindings*. The ports represent the application layer functionality to be provided: method calls that the web service supports. The bindings specify which network protocols are supported. For instance, if the data and arguments for the ports are carried in a SOAP [14] formatted packet, then the binding is said to be SOAP.

Both the ports and bindings for a web service are specified using the web service description language (WSDL) [6]. The specification of a web services is usually referred to as its WSDL description. If the functionality of a sensor node is expressed using a WSDL description, it can simply be accessed using the specified method calls.

<sup>1</sup>Currently, only members of the ZigBee Alliance may implement products based on the ZigBee specification.

## 3.2 Advantages

The use of web services on sensor nodes goes beyond simply enabling a new format for packet exchanges. It has the following significant advantages.

The first key advantage is interoperability. Our approach enables sensor deployments to be shared across multiple applications in a very flexible manner. Not only does it improve the performance of existing applications due to more sensors being available, but also enables deploying new applications that may not be cost effective to deploy if dedicated hardware is required. For instance, in the example shown in Section 1, once the sensors required for the security, medical monitoring, and energy management applications have been deployed, it becomes inexpensive to add a home automation application.

Second, the use of web services improves the programmability of the system. The WSDL description of the sensor node can be automatically parsed by high level language development tools such as Visual Studio and NetBeans IDE. The programmer only sees a high level language object with the appropriate methods. Using the sensor node in the application is as easy as calling the appropriate method calls of this object. The development tool and the protocol stack automatically generate the messages to be transmitted over the radio, receive the response, and simply provide the end result to the application. The programmer is no longer required to code multiple custom protocols.

A third advantage is the ease of integration with enterprise systems through the Internet. Many network applications are already built using web services. If similar interfaces can be supported on sensor nodes as well, much physically sensed data can be incorporated into the existing information technology infrastructures, enabling cyber-physical systems with many new capabilities.

Fourthly, the approach of running web services directly on the device eliminates the need for providing multiple gateways converting between the custom message formats of each sensor manufacturer and the applications.

In addition to the application layer advantages of web service based protocols, the use of IP for the network layer also provides many benefits, including ease of network management, use of DHCP based address assignment, and the ability to work with many PHY layers. The proposed 6lowpan specification reduces the IP overhead by header compression, and it also enables the use of sensor network-specific routing within the low power sections of a network to avoid the overheads of full scale IP routing on low-power nodes. Several routing protocols optimized for sensor networks have been developed and can be incorporated at the 6lowpan shim layer for routing. Several sensor network specific MAC layers have also been proposed and these can be implemented at the lower layers without affecting the web services application layer specification.

It may be noted that the web service approach is meant to improve the interface between sensor nodes and end user applications. The programming of the sensor nodes themselves is not significantly affected and existing tools such as [26, 15] may be used. The only impact is that a web service interface is provided along with its WSDL description. Some of the methods provided may even result in the node communicating with other nodes for in-network processing. These messages may continue to be in custom formats since they are not meant for client applications but are only used internally by a group of coordinating sensor nodes deployed together. The end result of such joint processing may be offered through the web service interface.

The many advantages of using the structured web service based approach come with a non-negligible resource cost. Conventional

wisdom calls for designing custom protocols that optimize message formats to the last bit for reducing communication energy overheads for matching the resource constraints of sensor networks. The obvious question then is: *are the resource costs of web service based interaction is acceptable?*

## 4. DESIGN SPACE EXPLORATION AND IMPLICATIONS

To address the above question regarding resource costs, we explore the design space relevant to supporting web services on sensor nodes. Compared to using raw data over the link layer, using web services involves overheads at three layers: the network layer (IP), transport layer (TCP) and the web service application layer. We address the challenges in each of these areas by first characterizing the overheads and then designing our system to minimize these overheads.

The feasibility of implementing TCP/IP on resource-constrained devices with limited code space has already been addressed in [10]. However, given the implementation, actually using it for hosting web services on sensor nodes leads to further challenges, in terms of the energy and latency costs of communication. For instance there is a  $\simeq 3000\%$  overhead in message size when using TCP/IP. We discuss the design choices including the effective use of persistent TCP, link layer retransmissions and related options to minimize the TCP/IP overheads. Our optimizations achieve significant reduction in overheads, reducing the latency to a mere 21ms for a TCP exchange, without losing compatibility.

The web service layer introduces significant overheads in message size and processing complexity. Our goal is to keep the energy and latency overheads to only what is needed for evolutionary and interoperable development. We optimize the operation of the web service layer by enabling the web service host sensor nodes to enter long sleep modes through the use of eventing. We also optimize web service message size overheads through efficient encapsulations and reduce the processing overhead of parsing XML messages by exploiting sensor specific information.

### 4.1 Network and transport layer design

We use TCP/IP at the transport and network layer as it is a widely used protocol and will support communication with a large number of applications. It has the added advantages of ease of network management using well-established tools, ease of interaction with existing IP based networks, and the better chance of adoption by a wider community. The TCP/IP standards were developed for always-on devices while sensor nodes must be duty cycled to achieve long battery lifetime. Any increase in the length of data transfers due to TCP/IP headers and control messages will lead to higher battery overheads. Effectively using these standards, even with an available implementation, is non-trivial.

To optimize our design and minimize these overheads, we characterize the latency associated with TCP/IP using the experimental setup from Section 5.1. We used *uIP* [10] as our TCP/IP implementation on sensor nodes. We obtained various TCP/IP performance measurements presented below by applying appropriate TCP/IP options.

#### 4.1.1 TCP/IP overheads

Consider a small amount of raw data (such as an event report with sensor values) to be transmitted, say 10 bytes. A conventional sensonet would transfer this data in a barebone 802.15.4 packet to reduce overhead. With TCP/IP, the packets must also carry 40 bytes of TCP/IP header. The minimum number of bytes required

for acknowledgment is 1 for the custom protocol while the standard TCP acknowledgment is used for TCP/IP. To examine the delay, message, and packet overhead associated with a TCP transfer, we capture network message timing for this communication, between a wireless sensor node and an application running on a PC.

Figure 3 shows the TCP message exchange and the timing captured at the sensor node and at the PC. Table 1 shows the various overheads due to TCP/IP compared to sending data directly using 802.15.4 packets. We observe that the percentage overhead due to TCP/IP is extremely large. The number of bytes sent, the number of packets sent, and the total latency are affected significantly.

	Minimum required	With TCP/IP	TCP/IP overhead
Packets	2	8	300%
Bytes	11	338	2973%
Delay (ms)	6	375	6150%

**Table 1: Overhead due to TCP/IP compared to sending raw data (assuming raw data is 10 bytes and acknowledgment in the absence of TCP/IP is 1 byte).**

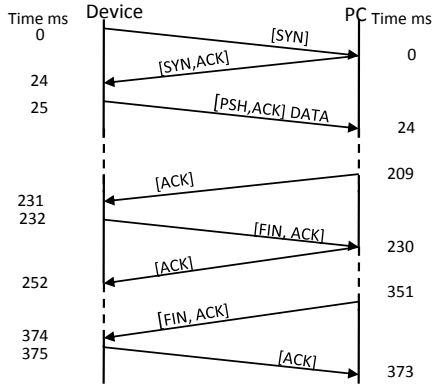

**Figure 3: TCP Message exchange latencies.**

#### 4.1.2 Optimizations for sensor nodes

It is possible to optimize the operation without compromising interoperability with standard devices. We examine some of the techniques for reducing the above overheads below.

**Persistent TCP connections.** The overhead in number of packets required for a TCP transfer can be reduced using persistent TCP. A typical use of TCP connections is for two machines to establish a connection, transfer some data, and terminate the connection. However, for a sensor node, all the web service-related communication would be with a small number of applications using it. Here, it is much more efficient for the client application to maintain a persistent TCP connection with the sensor node and use it to transfer data as needed. With persistent TCP connections, from the previous example (Figure 3), only 2 message transfers (message labeled [PSH, ACK] DATA and the corresponding [ACK] message) are needed, resulting in a latency of  $(231 - 25) = 206$  ms. This reduces the delay, number of packets, and number of bytes associated with a TCP transfer significantly. The only overhead for persistent connections is the TCP heartbeat message, which is very infrequent. However, persistent TCP connections introduce one complication when implementing web services. Our web service implementation

makes heavy use of the HTTP protocol. In the older HTTP specification (version 1.0), a web server indicates the end of data transfer by closing the TCP connection. The current HTTP 1.1 specification [13] mandates that an HTTP 1.1 client correctly interprets the `content-length`: field sent by the server to determine the end of a HTTP transfer, and ending the TCP connection is not required to indicate end of transfer. However, if a client application states the older version in the HTTP request header, the sensor node will be forced to terminate the TCP connection after the data transfer, and the reduction in overheads possible through persistent TCP will not be realized.

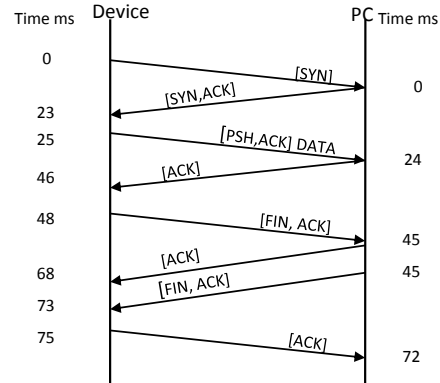
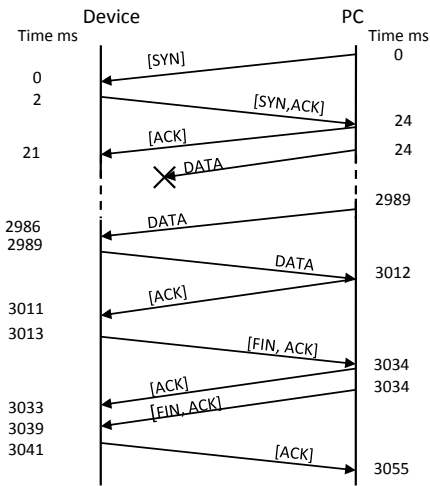

**Figure 4: TCP Message exchange latencies with delayed acknowledgments disabled.**

**Disable delayed TCP acknowledgments.** The latency overhead after using persistent TCP can further be reduced by disabling the delayed acknowledgment feature of TCP. TCP uses cumulative acknowledgments; an acknowledgment for byte number  $n$  acknowledges all the bytes up to  $n$ . Delayed acknowledgment feature uses the cumulative acknowledgment feature to reduce the number of messages sent over the network: after receiving a packet, the receiver waits for one other packet before sending the acknowledgment. For every other packet received at a host, the TCP protocol stack starts a 200ms timer. If another packet is received before this timer expires, an acknowledgment is sent immediately. Otherwise, an acknowledgment is generated when the timer expires. This mechanism works well when a TCP connection is used to transfer a long sequence of packets. However, when sending a single message at a time over a persistent connection, the delayed acknowledgment feature causes an extra  $\approx 200$ ms delay (the [209ms, 24ms] interval on the PC side in Figure 3) between sending of a message and the receipt of the acknowledgment. To reduce this delay, the TCP delayed acknowledgments must be disabled on both the host PC and the sensor node. Delayed acknowledgments is a TCP option; hence, turning off delayed acknowledgments does not require changes to the existing TCP implementations. However in current TCP implementations, unlike most TCP options, delayed acknowledgments can only be turned off at a network interface or machine level granularity. If applying this option at such a coarse granularity is a concern, a gateway device can act as a proxy and have the delayed acknowledgment feature turned off. This can be achieved without knowing the exact nature of new sensor nodes that may be added after the gateway is installed. Essentially, the application layer is not using the gateway and hence no sensor-specific information is used by the gateway; the gateway is only providing a TCP connection. Figure 4 shows the same data transfer as in Figure 3, with delayed acknowledgments disabled on the PC side.

We observe that the combination of no delayed acknowledgments with persistent TCP connections results in a, much smaller delay,  $(46 - 25) = 21$  ms, for transmitting the 10 byte payload and receiving the corresponding acknowledgment.

**Link layer retransmissions.** TCP uses packet retransmissions to achieve end-to-end reliability of data. These retransmissions incur significant delays. For example, in Figure 5, when the packet number 4 is lost due to a collision, that packet get retransmitted (packet number 5) only after a 2965ms delay. Such end-to-end retransmission is less suitable for wireless links since packet loss probability is higher compared to wired links. Similar to the use of link-layer ARQs in commonly used in wireless standards such as 802.11, we can recover almost all packet losses using much faster link layer retransmissions without causing TCP timeouts.



**Figure 5: TCP Message exchange latencies with TCP retransmission delay.**

**Low power mode between TCP messages.** The energy overhead for keeping the radio on can be further reduced by turning off the radio in between TCP messages. From the timing diagrams in Figure 3 and Figure 4, we observe that there is always some delay between a packet transmission and the corresponding reply. Although part of this delay will be random due to various network and application level randomness, there is a fixed minimum delay defined by the link capacities, hop count, and the packet size. If this delay is known, either through calculations or measurements, the battery-powered sensor node can safely sleep for this minimum period after receiving the link layer acknowledgment.

**6lowpan.** IPv6 is now being widely supported in many networks and this causes the network layer header size to increase beyond the overheads measured in our experiment above. In fact, the increased size of the header may even make the IPv6 packet too large to fit into a single 802.15.4 packet. The 6lowpan specification [21] provides a way for IPV6 packets to be transmitted over 802.15.4, with mesh routing and shorter addresses. The reduced length addresses suffice for ensuring unique node addresses within a local sensor network in most cases. Also, 6lowpan uses a 8 byte header (including *Mesh Under* header) compared to the 20 byte header used in IPV4 enabling further savings. Thus, when IPv6 compatibility is needed, the sensor nodes may use 6Lowpan and a standard 6lowpan gateway for connecting them to the rest of the IPv6 network.

**Link layer fragmentation.** The 802.15.4 radio packet can support a maximum of 127 bytes, including TCP/IP headers. With this

limited payload size, when a large amount of data needs to be sent over TCP, the data needs to be broken into multiple TCP segments resulting in increased message delivery times and power consumption. These overheads can be reduced using the link layer fragmentation provided by 6lowpan specification. This link layer fragmentation enables us to take a large TCP/IP segment and break it into multiple 802.15.4 packets, which can be sent as a burst of packets to limit the message delivery delays and to reduce the packet retransmissions by *acquiring* the channel for the duration of the packet burst. The shorter delays and reduced packet retransmissions also reduce the energy consumption.

## 4.2 Supporting duty cycled nodes

Traditional web service implementations assume that the server hosting the web service is typically on and available. Battery-powered sensor nodes however, must enter low power modes to conserve battery and they cannot be reached when in the low power state.

There are two main techniques for interacting with a sensor or an actuator node – one in which the node is always ready to receive messages (the client application connects to the node as needed) and the other in which the node is event driven (the sensor node sends an event when the sensor detects some interesting change). Considering the example of the home sensor network previously described (Section 1), one may observe that some nodes, such as the power actuator nodes on lights or power sockets, the heating controller, or other actuators may need to be always ready to receive messages. Regardless of whether web services are used or not, these nodes will need to be reachable when required.

On the other hand, sensors such as PIR-based motion sensors, glass-brake detectors, door intrusion sensors, smoke detectors, and several others benefit from event driven operation. If web services are not hosted on the sensor node, it may easily turn off its radio and enter deep sleep state, periodically polling its sensor or waking up on an interrupt generated by the sensor, to reduce energy consumption. It would turn on the entire node and radio only when an event is detected. A large class of sensor nodes fall into this category and if web services are to be used on such nodes without causing excessive energy overheads, the ability to enter sleep modes must be supported. One possibility is to use the duty cycling at the MAC layer, similar to what is available in 802.15.4 and 802.11. However, such MAC layer solutions use short sleep durations to preserve the responsiveness of the node, while a typical sensor that generates events has long inactive periods that can easily extend to several hours. Hence a MAC layer-based solution with an acceptable response time can increase the node energy consumption, compared to a solution that enables the node to sleep between sensing events. We support duty cycled nodes through the use of web service eventing (WS-Eventing) [28]. With eventing, a sensor node hosting a web service can be in sleep mode for the entire duration between sensing events.

WS-Eventing describes five functional entities (Figure 6):

1. *Event sources* that generate events (e.g. a smoke detector),
2. *Event subscribers* that are interested in a particular event,
3. A *subscription manger* that accepts and manages requests from subscribers,
4. An *event subscription database* that stores all active subscriptions, and
5. A *notification manager* that receives the original event and sends it to all active subscribers found in the database.

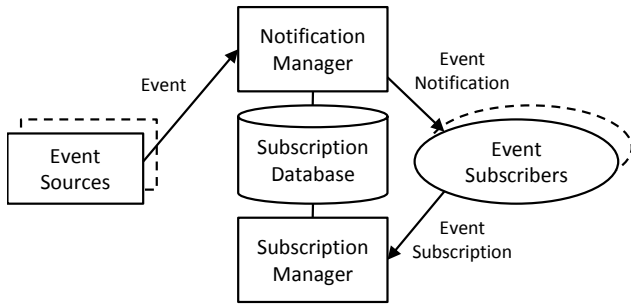

Figure 6: Web Services Eventing architecture.

When implementing WS-Eventing in a sensor network, the subscription manager and the notification manager should be implemented on a gateway device that is always on, rather than on the sensor node itself, to reduce computational complexity and energy consumption. A single such device can handle event subscriptions and notifications for multiple sensors (a fail over device may be used to eliminate the single point of failure in the system). WS-Eventing specifies only the interface exposed by the subscription manager and the notification manager, while the format and the delivery mechanism of an event is left open (although an XML message describing the event is preferred). This implies that any sensor node that is designed with the specified event subscription and notification interfaces can be supported by the gateway. New devices may be added without changing the gateway. The sensor node could define its own events and send notifications containing data that is semantically relevant to the sensor node's function. For instance, a smoke detector may generate events corresponding to smoke detection and low battery. To achieve the goal of structured data, our implementation encodes events in XML, and describes the events in the WSDL description of the sensor node.

### 4.3 Web service method encapsulation

As we described in Section 1, our web services implementation is centered around the WSDL standard. WSDL supports several encapsulation protocols for sending the method calls to the web service host device. Currently supported encapsulation protocols are SOAP, HTTP, and MIME. The `binding` section of the WSDL file describes which one of these standards is used for accessing device methods.

Currently, SOAP is considered the de-facto standard for transferring web service messages. However, a fully standards compliant SOAP server implementation requires considerable computational and memory resources than those provided by low-power processors such as MSP430. The SOAP envelop is very verbose and also needs significant radio bandwidth. Referring back to the home sensor network example discussed earlier, two of the method calls used by the applications are listed in Table 2 along with the byte size for their SOAP encapsulations (two versions of SOAP are in common use and are listed). Both the processing complexity and the message size make the use of SOAP incompatible with the resource constraints of a sensor node. Most of these envelopes are too large to fit within a single 802.15.4 packet, and fragmentation will also worsen the communication latency.

However, SOAP provides much more functionality than what is required for accessing devices with limited functionality. A more lightweight approach for sending web service messages is to use HTTP. Since a standards compliant HTTP sever can easily be implemented on a resource-constrained processor such as an MSP430,

Method Name	SOAP 1.1	SOAP 1.2	HTTP
GetTemperature	491	442	162
GetTemperatureResponse	479	499	258
SetTemperature(70)	528	482	202
SetTemperatureResponse	455	475	230

Table 2: Web service message sizes for different encapsulations.

HTTP binding becomes the ideal choice for sensor networks. Apart from the reduction in the computational complexity, the HTTP bindings also result in smaller messages (Table 2) due to the elimination of the relatively large SOAP envelopes from method calls.

The WSDL standard specifies multiple techniques for encoding method calls and call parameters within HTTP. The first one, called URL Encoding, maps the method call to a particular path within the HTTP server. For example, the `SetTemperature()` method on the sensor with IP address `192.168.1.4` may map to the `http://192.168.1.4/setTemp` URL. The URL encoding technique for sending method parameters specifies a direct mapping between different fields (tags and parameters) in an XML document representing a method call and the parameters encoded in an HTTP GET request. The URL encoding method is identical to the way parameters are passed in a URL using an HTTP query string when an HTML form is submitted with a GET request. For example, the `SetTemperature(25)` method can be encoded as `http://192.168.1.4/setTemp?temp=25`. The second option, called URL Replacement, is similar to URL encoding except that instead of encoding the parameters in a HTTP query string, the parameters are mapped to the path of the HTTP GET URL. The `SetTemperature(25)` method described above can be encoded as `192.168.1.4/setTemp/temp/25`. The third option is XML POST. In this approach, an XML formatted string is sent containing the method name and parameters, using HTTP POST. The sensor decodes the XML string and extracts the method parameters.

All the above methods are supported by the standard and the WSDL description of the sensor node's web service can specify which alternative is used. The web service implementation on the host sensor node should use the URL encoding or URL replacement methods whenever possible. First, these techniques results in a smaller message size compared to sending a full XML message; second, the decoder for the URL encoding/replacement can be much simpler than for XML encoding. In section 5, we show that simple method calls can easily be encoded within a single 802.15.4 packet. However, if the method parameters are specified within a complex XML message with varying number of elements (e.g. a variable length array), it may not be possible to specify a direct mapping from method parameters to a URL encoding/replacement, requiring a POST-based XML solution.

### 4.4 XML parsing on sensor nodes

XML parsing at the sensor node is only needed when URL encapsulation does not suffice, such as for passing structured arguments. The overheads of implementing a general purpose XML parser are unlikely to be compatible with the resource constraints of a low-power processor. However, a key observation is that, when the device functionality is limited, the WSDL description only exposes a small number of methods and events. All messages that the sensor is required to respond to are created as specified in the WSDL description provided by the sensor. Clearly, the XML parser on the sensor can be designed to only parse the simple messages that it expects. Thus, simple text matching to search for the method

name and argument names suffices. Typically, the sensor node manufacturer who specifies the WSDL implements the parser. Although such a parser can be auto generated from the WSDL, we implemented a hand-coded custom XML parser on each device. The use of a custom parser remains transparent to the client applications since they receive web service responses or events as specified in the WSDL description and the sensor node remains fully compliant.

#### 4.5 Compression and optimization

The XML format used for structured representation of data and methods was not designed for constrained sensor nodes and can be very verbose. There are several techniques that can be used to help reduce the message size increase due to XML. A first approach is to use compression. Either generic compression based on LZW algorithms, such as zip, or XML-specific compression methods (sometimes referred to as binarization since they do away with the text representation) such as [5, 2] may be used. This approach does require a predetermined compression scheme be chosen and implemented by sensor nodes as well as a gateway node that connects the sensor network to rest of the network. The message size after compression is shown in Table 3 for generic (Zip) and XML specific (XMLPPM) compression. A second approach is to optimize

Compression	GetTemp.	GetTemp-Response	SetTemp.	SetTemp-Response
Original	85	181	125	153
Xmlppm	65	98	85	92
Zip	114	157	138	151
Comp1	81	101	101	107
Comp2	26	46	46	53

**Table 3: Sizes of request and response message payloads (excludes encapsulation) with different compression schemes.**

the XML format by replacing some the method names and argument names that are defined by the sensor node, with very compact tags. For instance, the method name `GetTemperature` that is 14 bytes (112 bits) may be replaced by single byte (allowing up to  $2^8$  tags within a single WSDL description). The XML node and element markers are left uncompressed for automated tools to continue working as before. For human readability, a dictionary that lists the mapping from the compact tags to the human readable method or parameter names may be provided. Table 3 also shows the compression achieved using this approach, labeled `Comp1`. A further variation, where in addition to the method names and parameters, the common strings such as the XML header marker and namespace URL are also replaced with compact tags, labeled `Comp2`, is also shown.

Since the XML payloads in the sensor node method calls in our application context are relatively small, the use of Zip is not very efficient. The second approach of using compact tags is most efficient. The tag mapping dictionary is retrieved only infrequently from the sensor node, similar to the access frequency of the sensor WSDL.

## 5. EVALUATION

We implemented web services on a resource-constrained sensor node, using the design choices discussed in the previous section. In this section we evaluate the performance of the web services implementation, in terms of its communication, energy, and code-complexity overheads.

Detailed measurements reveal that for a variety of practical scenarios, the overheads in energy and latency are very acceptable. For instance, for a sensor node generating one event every 10 minutes, the reduction in battery lifetime is only 10.84%. The latency increase is within a few tens of milliseconds and is typically acceptable for most sensing applications. The measurements also reveal scenarios where the overheads may lead to significant performance degradation.

### 5.1 Experiment setup

The evaluations require detailed visibility into the latency and energy overheads due to the increased message sizes, processing overheads, and increased number of packets due to the web service based approach. We use the setup shown in Figure 7 to measure the fine-grained timing behavior of communication over 802.15.4 radio links.

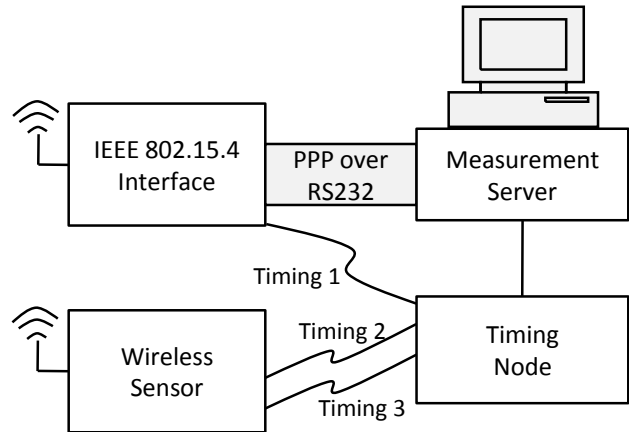
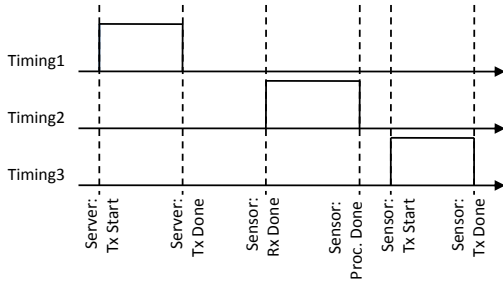

**Figure 7: Experimental setup for evaluating network performance**

A measurement server is set up with an IEEE 802.15.4 network interface<sup>2</sup>. The wireless sensor used is our prototype node (Figure 2) consisting of a MSP430F1611 processor running at 6MHz and a CC2420 radio. This node runs the *uIP* TCP/IP implementation [10] along with our web service implementation. To obtain packet transmission and processing delays, we disabled the random delays between the application's `send()` command and the start of CC2420 data transmission. We used a timing node consisting of a MSP430, wired to the server over USB, to collect timing of various events at the sensor node and the server's wireless interface. To obtain timing, we connected a wire, denoted as signal (`Timing1`), to the server's wireless interface and 2 wires, (`Timing2` and `Timing3`), to the wireless sensor. Figure 8 shows the timing of the three signals `Timing1 ... Timing3`: the server's wireless interface asserts the `Timing 1` signal when it starts sending a radio packet, and clears it when the packet transmission is finished. The wireless sensor asserts the `Timing2` signal on receiving a radio packet, and clears it after processing the packet. The sensor asserts `Timing3` when it starts sending a packet, and clears it after the packet is sent. The difference between, `Timing1` and `Timing2` represents the time taken by the sensor to decode and assemble the packet in the radio module. To obtain accurate timing,

<sup>2</sup>The 802.15.4 interface is a MicaZ mote connected on the serial port at 115200 baud, using the PPP [25] protocol. A local IP subnet is implemented over this PPP connection, bringing the packets received on the radio to the server's TCP/IP stack.





**Figure 8: Communication activity timing in the experiment set up.**

the timing node used a temperature compensated clock source running at 6MHz. To capture timing at the server, the Wireshark packet sniffer was used. A single run using this setup produces an output of the form shown in Table 4. This sample output also shows that the packet processing times on the sensor, that include the web service method call parsing and the TCP/IP stack processing, are very small: for the first packet the processing time is  $10.67 - 9.68 = 0.99\text{ms}$  and for the second one, it is  $36.35 - 35.53 = 0.82\text{ms}$ .

Time (ms)	Event	TCP Action
0.00	Server Tx start	TCP data
6.19	Server Tx done	(74 byte request)
9.68	Sensor Rx done	
10.67	Packet processed	
10.68	Sensor Tx start	TCP ACK
11.71	Sensor Tx done	
29.29	Server Tx start	TCP data
33.35	Server Tx done	(27 byte request)
35.53	Sensor Rx done	
36.35	Packet processed	
36.36	Sensor Tx start	TCP data
37.78	Sensor Tx done	(37 byte reply)

**Table 4: Message communication and processing times.**

## 5.2 Energy cost

The use of TCP/IP and structured XML data for web services increases the message sizes and hence the energy consumption at sensors. The increased energy consumption reduces the battery life. In this section, we examine the impact on battery life due to web services. Suppose the application wishes to transfer  $x$  bytes of payload. A barebone protocol can send this data directly over 802.25.4 packets with no additional headers, while the web service approach does involve the TCP/IP and encapsulation headers. For encapsulation, we use HTTP 1.1 that has request and reply headers of 21 and 37 bytes respectively. We vary  $x$  from 1 to 80. Payload sizes for example methods in our prototype (Table 3) lie in this range with XML optimization. With web services, when  $x$  is increased beyond 53 bytes, two packets are needed to transmit the complete request (due to TCP/IP and HTTP headers) while in the barebone case one packet suffices. As discussed in section 4, we use persistent TCP connections and disable TCP delayed acknowledgments.

For the energy numbers, we use a MSP430F1611 processor running at 5MHz (internal DCO) consuming  $\approx 3\text{mA}$  when active, and  $2\mu\text{A}$  during sleep, and a CC2420 radio that consumes  $18.8\text{mA}$  in receive,  $17.4\text{mA}$  in transmit (0dBm output power), and  $0.02$

$\mu\text{A}$  in sleep modes. Timing is measured using the experimental setup from section 5.1. We use this timing to compute the power consumption and the resultant battery lifetime assuming two AA (2200 mAh) batteries. The battery self-discharge for typical alkaline batteries is used:  $\approx 3\%$  loss of capacity per year due to self discharge [3]. With time  $t$  expressed in years, this yields the capacity,  $c(t)$  at time  $t$  as:  $c_t = c_0 e^{-t \times \ln(0.97)}$  where  $c_0$  is the initial capacity. The battery is assumed dead when the voltage falls to 1.05V (corresponding to  $c(t_{dead}) = 400\text{mAh}$ , using the battery discharge curve) from the initial 1.5V.

Figure 9(a) shows the battery life assuming that the radio is turned off during the gaps between TCP message transmissions, and Figure 9(b) shows the battery life if the radio is kept powered on (receive mode) during the whole TCP transfer, for both the web service (WS) and the barebone approaches. The three curves represent three application scenarios requiring one message every 1 minute, 10 minutes, or 100 minutes.

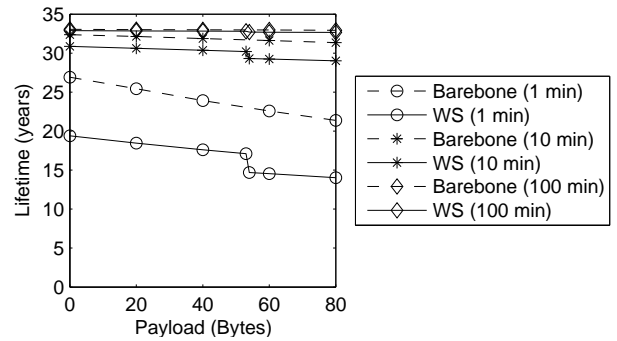

(a) Radio Off Within Transfer

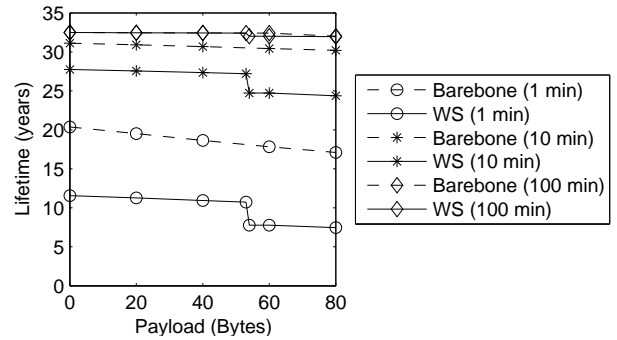

(b) Radio On For Entire Transfer

**Figure 9: Battery life variation with client request size.**

We observe that incremental cost due to different message sizes is comparatively small compared to the total battery life, when the complete message can fit inside a single packet. When a message is sent every 10 minutes, the reduction in lifetime is 4.74% at a request size of 40 bytes, and with the radio on for the entire TCP transfer, the reduction is 10.85%. The reduction becomes more significant with very frequent message exchanges, such as once every minute are considered, but such high rates are less likely to be needed. In our prototype deployment of the home energy management application over 12 days (Section 6.2), we observed that sensor states for door intrusion sensors, motion sensors, and power sensors changed only 2 to 20 times a day, keeping the event generation rate between once every 100 minutes to once every 10 minutes. Also, while at high message rates, there is a significant impact on

lifetime when the request splits into multiple packets under the web service approach, the impact becomes negligible at more practical message rates.

In summary, we observe that the incremental cost of using web services is not significantly higher than the barebone protocol. The comparisons made above in fact give an unfair advantage to the barebone protocol. In the above evaluation, we assumed there are no overheads due to message retransmissions, carrier sensing delays, link layer acknowledgments, or radio wake-up schemes. The communication was assumed to be synchronized so that radios were turned on only during active communication. In practice, such packet losses and retransmissions will occur and even the barebone protocol usage will involve some overheads in waking up the next-hop nodes before transmission. When such overheads are included in the comparison, the incremental overhead of web services would be even smaller.

### 5.3 Response time

In certain time-critical sensor network applications, such as those involving human interaction, the response time of the system becomes very important. Consider as an example the time to turn on a lamp when a home automation application on the user's cellphone sends a turn-on request. While web service overheads are acceptable for most of the network links, the latency increase on the last leg involving 802.15.4 links to the sensor is a concern. Assume for such applications that the wireless sensor/actuator is already on. The lamp power actuator in the previous example may stay on by using power from the wall socket. The wake-up overheads, if involved, would be similar for a barebone protocol or the web service approach.

The response time depends on the time taken to complete a web services method call. We measured the response time for varying web method request sizes, using the setup from Section 5.1. Figure 10 shows the results. We note that the response time is not significantly affected by the request size as long as the request can fit in to a single IP packet (53 bytes of request payload). For a 40 byte payload at an average message rate of once every 10 minutes, the latency increase is only 23.09ms.

The delay is a few tens of milliseconds, even when the request breaks up into two packets. There is a potential to reduce the delay increase when the payload splits across multiple packets even within the web service based approach. The delay increases sharply because the TCP/IP stack from *uIP* used in our prototype sends and acknowledges each packet individually. Schemes such as fragmentation and reassembly at the link layer (Section 4) or sending multiple packets without having TCP wait for individual packet acknowledgments can reduce this delay in case of larger web method requests.

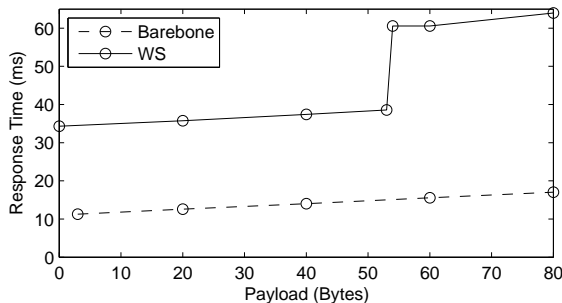

Figure 10: Response time for comparison.

## 6. PROTOTYPE IMPLEMENTATION AND DEPLOYMENT

In this section, we demonstrate the use of our web services solution to support an evolving sensor network deployment in the context of a home energy management application. We also show that the ROM space required by our prototype implementation for hosting a power sensor web service on a low power sensor is only 15.8k, including the XML parser, HTTP server, and the TCP/IP stack. We also present the design of our power sensing and actuating node along with a 12 day deployment of the home energy management application.

### 6.1 System description

We implemented web services on a resource-constrained platform using an MSP430 processor and an 802.15.4 radio (Figure 2). A central controller was implemented on PC with a 802.15.4 network interface. Figure 11 shows the block diagram of our implementation.

The components shown in the figure are described below:

**Sensors:** Each sensor node contains two WSDL files that describes the WSDL ports and binding: `dev.wsdl`, specifying the method calls supported by a device, and `bindings.wsdl`, specifying how the methods are encapsulated and transported. The information in `dev.wsdl` completely describes the method names, parameter names, and the data types of the parameter and return values. The `bindings.wsdl` WSDL file imports the `dev.wsdl`, making `bindings.wsdl` the complete WSDL description of the sensor. For devices that generate events, `bindings.wsdl` includes three additional methods, and a separate Port type. Two of these methods, `void eventOn(string eventName)` and `void eventOff(string eventName)` are used for enabling and disabling specific events; the other method `void setHandlerURL(string url)` sets the URL to which the events are posted. These three methods are only accessible by the *Controller* while the methods defined in `dev.wsdl` are accessible to applications. As described in section 4, `bindings.wsdl` uses HTTP bindings with URL encodings for method calls, and XML messages for return values. The sensor runs an HTTP server for accessing WSDL files and for calling device methods.

Table 5 shows the RAM and ROM storage requirements for implementing web services on the power sensing node, including the storage for the WSDL files. The column labeled 'Const' represents the constants stored in ROM. As the table shows, the device imple-

Module	Code (bytes)	Data (bytes)	Const (bytes)
Libraries	804	2	76
Hardware control	408	78	12
Radio Driver	4282	404	14
TCP/IP	2964	332	4
Web server+ XML parser	2380	54	4864
<b>Total</b>	<b>10838</b>	<b>870</b>	<b>4970</b>

Table 5: Power sensor memory usage.

mentations can easily fit inside a low-power processor such as the MSP430. The two WSDL files `dev.wsdl` and `bindings.wsdl` are large: 2.7kB and 1.3kB respectively. However, this is not a major concern since they are accessed only very infrequently, for populating the controller's internal state as described in the following sections.

**Sensor Registrar:** The registrar is responsible for registering new devices with the controller. In our current implementation, a user

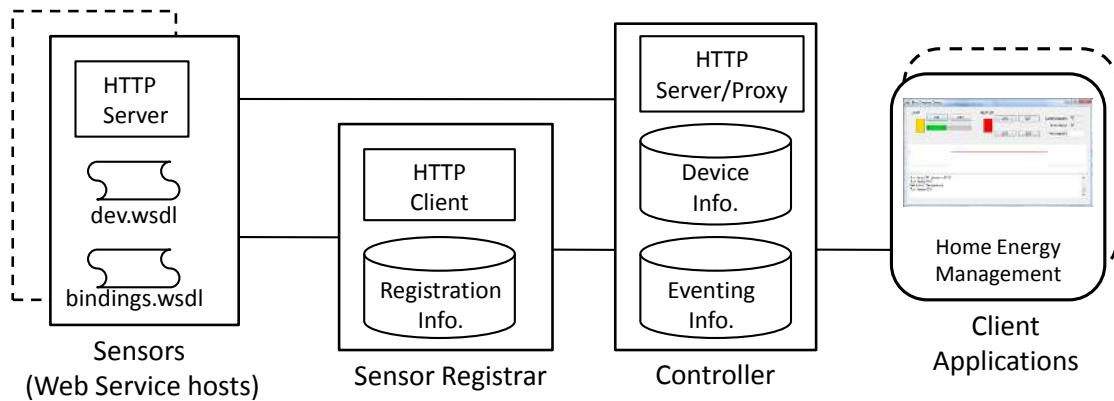

Figure 11: Block diagram of web services implementation for sensor networks.

enters a pre-assigned device IP address and a user-friendly device name using a GUI. Future work includes supporting DHCP-based address assignment and exchanging a secret key for link layer security. Once a sensor is registered, the registrar accesses the device and downloads the two WSDL files. It combines these two WSDL files, the user-friendly name, and the device IP address into a single XML file and uploads it to the Controller. Although currently implemented on a PC, registrar and the controller may be implemented on a device such as an 802.15.4 access point or a set-top box.

**Controller:** The controller acts as the central entity that bridges the sensor network and the client applications that wish to use the sensors. The controller acts as an HTTP server for registering new devices and for accessing the currently registered list of devices. When a client application or a web browser, accesses the `http://Controller/index.htm`, the Controller dynamically generates an HTML page listing the currently registered sensors. Each sensor's listing also includes a link to a sensor WSDL description of the form `http://Controller/wsd1/<sensorName>.wsdl`. When the sensor WSDL link is accessed, the Controller uses the sensor's stored WSDL files to dynamically generate a new WSDL file with SOAP bindings, in place of the original HTTP binding in the sensor's `bindings.wsdl`.

The SOAP bindings allow additional SOAP-based functionality to be supported on connections between the Controller and the client applications. For instance, the client applications may be running on a device connected to the home through the Internet, and the security features of SOAP may be used for authenticating this access. Note that the conversion of bindings does not require sensor specific knowledge, and can be performed for old or new sensors added to the system. This conversion also has a side effect that some web service development tools that only support SOAP bindings can also be used by the client application developer. When a client application calls a sensor's method using SOAP, the Controller intercepts the SOAP message, extracts the method name and method parameters, and sends them to the sensor using HTTP bindings. If the call is successful, the controller encapsulates the XML file returned from the sensor within a SOAP message and returns the SOAP message to the application. If the call fails (an HTTP error message is received), the Controller returns a SOAP fault. The Controller also implements the event subscription manager, subscription database, and notification manager required for eventing (Figure 6). When an application subscribes to a sensor event, the

Controller updates its subscription database and itself subscribes to this event by using the sensor's event subscription method call. Whenever the sensor generates the event, the Controller (being also the notification manager) distributes the event to all client applications that have subscribed to it.

The sensor may enter a low power state with its radio turned off after receiving a threshold number of event subscription requests, assuming some applications are using the data it generates. It will now turn on its radio only to transmit events when generated. If more applications wish to call any of the web service methods on the sensor, the Controller must wait for the sensor to wake up and then send the method call to it. Since this can have a significant delay, client applications may benefit from using the asynchronous mode for a sensor's web service method calls. Our current implementation does not support this functionality yet. The Controller can use methods such as repeated beaconing [24] to wake up sensors or simply wait for the sensor to wake up at a scheduled time for achieving this functionality.

**Client Applications:** The client applications are end user applications that use the sensor network through the web service interfaces. They call the methods exposed by sensors using SOAP method calls to the sensor's web service address as provided by the Controller-generated sensor WSDL description. Web services development environments such as Visual Studio and NetBeans IDE can automatically parse the WSDL description to generate a high level language object, such as a Java object, that represents the web service on the sensor. The application developer simply calls the methods of this object to use the sensor. The developer only needs to know the semantics of the sensor, such as how to use the sensor data (for instance, temperature may be used to control the heating), but does not need to read any detailed documentation about how the arguments required to be sent for a particular functionality are represented in a bit sequence or what is the sequence of packet exchanges required. The client application in our system, home energy management, and its deployment are discussed in the next section.

## 6.2 Home energy management application

As an example of an evolutionary sensor system we present a home energy management application that uses sensors that are typically deployed for other home sensor networking applications such as security and medical alerts. The energy management application adds a small number of new nodes in the existing network.

The new nodes are power sensors that provide the capability to both measure the power drawn by the appliance plugged into it and to power on or off that appliance. The application also includes a GUI that lets a user manually control the power actuators or visualize the energy usage of appliances plugged into our power sensors.

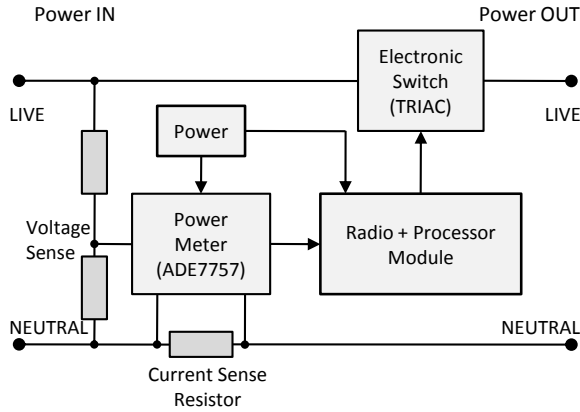
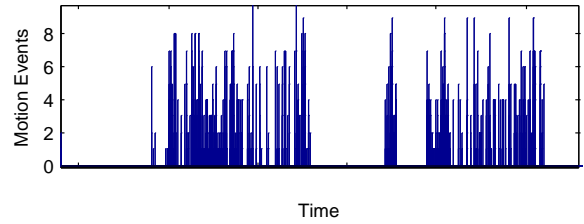

Figure 12: The smart-socket block diagram.

The sensor platform used is our prototype shown in Figure 2. We also built the power sensor-actuator node, denoted a “smart-socket.” A block diagram of the smart-socket is shown in Figure 12. The smart-socket plugs into an existing wall power socket and provides another socket to plug in the appliance. Our design supports appliances up to 2kW which is sufficient for most typically used lamps, home entertainment electronics, home computers and network equipment, and kitchen appliances. The measurement and visualization of power consumption is known to be useful for saving energy [23] the smart-socket may be used in an energy visualization system to help users reduce their carbon footprint. Our home energy management application goes one step further and uses the smart-sockets in conjunction with other sensors in the home to automatically reduce energy usage.

We deployed the power and motion sensors in a volunteer family’s home for a period of 12 days. Smart-sockets were deployed on most-used entertainment electronics and lamps. To represent the evolutionary deployment, we assumed that a medical alert application has already deployed motion sensors in the home (we built these by interfacing an off-the-shelf motion sensor [22] to a Telo mote). Motion sensors were deployed in the living area, study room, and each bedroom. To represent the sensors deployed as part of the security system, we obtained the data from the same home’s security system. This system had an on-line interface exposed by its monitoring company’s website that allows downloading security sensor data. Sample traces from a motion sensor in the living area, the main door security sensor, and a smart-socket connected to a dim-able lamp are shown in Figure 13. The time axis details are omitted to protect the volunteer family’s privacy. The home energy management application uses the data from multiple sensors to determine whether the home is occupied, and which room is the one occupied. This information can be used to save energy spent on heating, home electronics, and lighting by turning off devices when not required.

**Energy Savings:** To illustrate the usefulness of the evolutionary approach, we use the motion activity to control the heating. The energy savings achieved by the evolutionary application are shown in Figure 14. Total reduction in heating energy was 7.2%<sup>3</sup>. Energy is



(a) Motion sensor, partial trace

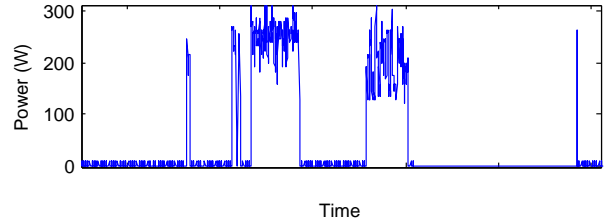

(b) Power Sensor, partial trace

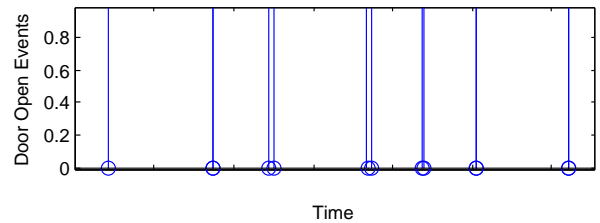

(c) Security sensor, partial trace

Figure 13: Test case: sample data from a deployed home energy management system.

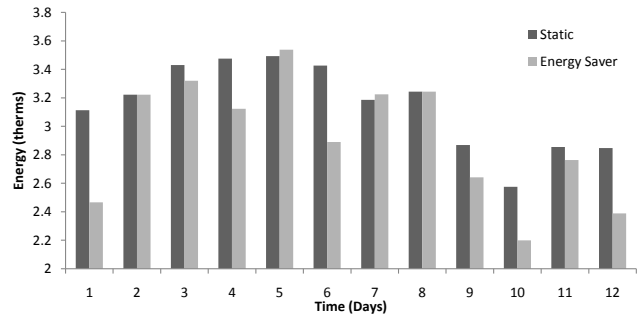

Figure 14: Savings achieved by adding an energy management application to a home sensor system.

saved by setting the desired temperature to a lower value when the home is not occupied. The algorithm aggregates the motion output from all motion sensors to determine home occupancy status and sets the indoor temperature to a lower value. Since the furnace in the deployment home was not interfaced to our sensor network we experimentally measured the home’s heat loss model<sup>4</sup> and the heating furnace energy usage. The energy savings were then computed

<sup>3</sup>The monthly gas consumption was 90.8 therms and these savings with the local energy price convert to USD 8.44 per month.

<sup>4</sup>Heat loss over time duration  $\Delta t$ , denoted  $Q_{loss}(\Delta t)$ , is propor-

based on these models. While for illustrative purposes, we used a simple algorithm that infers only home occupancy from sensor data to save energy, more sophisticated energy management algorithms may be designed that use the sensor inputs to control the heating by individual zone within the home, and control energy usage other than for heating. The design of the energy saving algorithm and the details of the illustrative algorithm used are beyond the scope of this paper.

## 7. DISCUSSIONS

Our design space exploration and prototype implementation demonstrated how structured data and programmatic specification of functionality can be enabled in resource-constrained sensor nodes. For a range of usage scenarios, the battery lifetime impact is very acceptable, and the increase in communication latency is only a few tens of milliseconds. For instance, when transmitting a 40 byte message every 10 minutes, the battery lifetime impact was estimated as 10.84% with a 23.09ms increase in response time for message exchanges. We also saw that many optimizations can be made that make the implementation of web services on sensor nodes to be very efficient in terms of processing complexity and memory sizes required. For instance, we greatly simplified the XML parser by exploiting the fact that the sensor node is only required to respond to messages specified in its own WSDL description, reducing the entire stack containing the web service, HTTP server, TCP/IP, 802.15.4 radio driver, and related libraries to a very compact 15.8kB. While web services are traditionally used for always-on systems, we showed how sleep modes could be used when battery-powered sensor nodes host the web service. Thus, with appropriate design and implementation decisions, web services become feasible on resource-constrained sensor nodes and enable the deployment of evolutionary sensor networks that can be used by multiple applications.

The web service approach is designed for end-user applications to access sensor nodes. It does not change the need to develop efficient programs on the sensor nodes, and tools such as [26, 15] are required for that purpose. Acquisition and processing of data on the sensor node is performed as before. The key change is that the message interface exposed to external applications uses structured data and WSDL descriptions.

While our explorations address many of the design challenges in realizing the benefits of web services in sensor networks, further issues remain.

**Sleep modes:** A key design characteristic of battery-powered sensor networks is that the nodes must enter disconnected sleep modes. This affects the operation of TCP/IP and web service interaction. We showed that using eventing and persistent TCP helps support the sleep modes. However, further work is needed to ensure that all network layer message exchanges, such as for network management, and interactive web service data transfers are designed considering the sleep mode. For instance, the gateway connecting the 802.15.4 network to the Internet could buffer packets destined to sleeping nodes and have mechanisms to send wake-up messages, possibly at the link layer. Applications may use the web method calls in an asynchronous manner.

**Mesh overheads:** We presented our evaluations without considering the multi-hop networking overheads. With multi-hop connections to the difference between interior and exterior temperature:

$$Q_{loss}(\Delta t) = \alpha * \Delta t * (T_{in} - T_{out})$$

where  $\alpha$  was experimentally estimated by measuring interior temperature  $T_{in}$  and exterior temperature  $T_{out}$ , for multiple values of  $\Delta t$ , with the furnace turned off.

tions, each hop in the communication will also have node wake-up, route maintenance, and MAC layer congestion overheads. All these overheads will affect both a barebone message protocol with small message sizes as well as our structured data format. Evaluating the exact proportion of the overhead needs further experimentation.

**Security:** It is also necessary to ensure that mechanisms to provide message privacy work correctly with the web service approach. A shared-key security architecture, where each sensor shares its unique key with the gateway can be used for message encryption. When unique shared keys are used in a multi-hop network, one must ensure that the intermediate nodes can read the parts of the message that contain addressing information; similarly, the 6lowpan header should not be encrypted so that the 6lowpan message can be converted to an equivalent IPv6 packet without having to decrypt the entire message. The CC2420 provides 128-bit AES encryption in hardware. The portion of the 802.15.4 packet to be encrypted can be specified, thus enabling access to routing and 6lowpan header information at intermediate sensors without giving access to data. CC2420 also enables automatic nonce generation and verification for protection against replay attacks. Shared-key encryption needs a mechanism to establish the shared secret between a sensor and the gateway. One solution is to generate the key at the gateway, and then communicate it to the sensor using a limited-range communication link that lasts only for a short duration. The spatial and temporal proximity of the sensor and the gateway reduces the risk of an eavesdropper getting the key. Another solution is to manually exchange a short key between the sensor and the gateway, and use this short key to establish a stronger key [4].

## 8. REFERENCES

- [1] Arch Rock Corporation. An IPv6 network stack for wireless sensor networks. "http://www.archrock.com/downloads/Arch\_Rock\_6LoWPAN\_Whitepaper.pdf".
- [2] C. Augeri, B. Mullins, L. Baird, D. Bulutoglu, and R. Baldwin. An Analysis of XML Compression Efficiency. In *Proc. of ACM Workshop on Experimental Computer Science (ExpCS '07)*, June 2007.
- [3] Alkaline Manganese Dioxide handbook and application manual. [http://data.energizer.com/PDFs/alkaline\\_appman.pdf](http://data.energizer.com/PDFs/alkaline_appman.pdf).
- [4] P. Chandra. *Bulletproof wireless security: GSM, UMTS, 802.11*. Elsevier, 2005.
- [5] J. Cheney. XML specific compression tools. <http://sourceforge.net/projects/xmlppm>.
- [6] R. Chinnici, J.-J. Moreau, A. Ryman, and S. Weerawarana. Web Services Description Language (WSDL) Version 2.0. <http://www.w3.org/TR/wsd120/>. W3C Recommendation.
- [7] H. Combs, M. Gudgin, J. Justice, G. Kakivaya, D. Lindsey, D. Orchar, A. Regnier, J. Schlimmer, S. Simpson, H. Tamura, D. Wright, and K. Wolf. Soap-over-udp. Global XML Web Services Specifications.
- [8] L. M. S. de Souza, P. Spiess, M. Köhler, D. Guinard, S. Karnouskos, and D. Savio. SOCRADES: A Web Service based Shop Floor Integration Infrastructure. In *IOT*, volume 4952 of *Lecture Notes in Computer Science*. Springer, 2008.
- [9] A. Deshpande, S. Nath, P. B. Gibbons, and S. Seshan. Cache-and-query for wide area sensor databases. In *SIGMOD '03 : Proceedings of the 2003 ACM SIGMOD international conference on Management of data*.
- [10] A. Dunkels. Full TCP/IP for 8-bit architectures. In *MobiSys '03: Proceedings of the 1st international conference on*

- Mobile systems, applications and services*, pages 85–98, New York, NY, USA, 2003. ACM.
- [11] A. Dunkels, J. Alonso, and T. Voigt. Making TCP/IP viable for wireless sensor networks. In *Work-in-Progress Session of the first European Workshop on Wireless Sensor Networks (EWSN)*, 2004.
- [12] Energy Star. <http://www.energystar.gov/>.
- [13] R. Fielding, J. Gettys, J. Mogul, H. Frystyk, L. Masinter, P. Leach, and T. Berners-Lee. Hypertext transfer protocol – http/1.1. <http://www.w3.org/Protocols/rfc2616/rfc2616.html>. IETF RFC 2616.
- [14] M. Gudgin, M. Hadley, N. Mendelsohn, J.-J. Moreau, H. Nielsen, A. Karmarkar, and Y. Lafon. SOAP Version 1.2 Part 1 : Messaging Framework (Second Edition). <http://www.w3.org/TR/soap12-part1/>. W3C Recommendation.
- [15] C.-C. Han, R. Kumar, R. Shea, E. Kohler, and M. Srivastava. A dynamic operating system for sensor nodes. In *ACM MobiSys*, pages 163–176, 2005.
- [16] J. Helander. Deeply embedded xml communication: towards an interoperable and seamless world. In *EMSOFT '05 : Proceedings of the 5th ACM international conference on Embedded software*, pages 62–67, 2005.
- [17] J. Helander and Y. Xiong. Secure web services for low-cost devices. In *ISORC '05 : Proceedings of the Eighth IEEE International Symposium on Object-Oriented Real-Time Distributed Computing*.
- [18] Energy information administration: Residential energy consumption survey 2001. <http://www.eia.doe.gov/emeu/recs/recs2001/detailcetbls.html>. Official Energy Statistics from the US Government.
- [19] J. Lifton, M. Feldmeier, Y. Ono, C. Lewis, and J. A. Paradiso. A platform for ubiquitous sensor deployment in occupational and domestic environments. In *ACM/IEEE IPSN*, pages 119–127, New York, NY, USA, 2007. ACM.
- [20] A. Mainwaring, J. Polastre, R. Szewczyk, D. Culler, and J. Anderson. Wireless sensor networks for habitat monitoring. In *First ACM Workshop on Wireless Sensor Networks and Applications*, Atlanta, GA, USA, September 2002.
- [21] G. Montenegro, N. Kushalnagar, J. Hui, and D. Culler. Transmission of IPv6 packets over IEEE 802.15.4 networks. <http://www.ietf.org/rfc/rfc4944.txt>. IETF RFC 4944.
- [22] Parallax. PIR sensor 555-28027. <http://www.parallax.com>.
- [23] J. E. Petersen, V. Shunturov, K. Janda, G. Platt, and K. Weinberger. Dormitory residents reduce electricity consumption when exposed to real-time visual feedback and incentives. *International Journal of Sustainability in Higher Education*, 8(1):16 – 33, 2007.
- [24] C. Schurgers, V. Tsiatsis, S. Ganeriwal, and M. Srivastava. Optimizing sensor networks in the energy-density-latency design space. *IEEE Transactions on Mobile Computing (TMC)*, pages 70– 80, January-March 2002.
- [25] W. Simpson. The point-to-point protocol (PPP). <http://tools.ietf.org/html/rfc1661>. IETF RFC 1661.
- [26] Tinyos: a component based os for the networked sensor regime. <http://webs.cs.berkeley.edu/tos/>.
- [27] G. Werner-Allen, K. Lorincz, J. Johnson, J. Lees, and M. Welsh. Fidelity and yield in a volcano monitoring sensor network. In *7th USENIX Symposium on Operating Systems Design and Implementation (OSDI)*, November 2006.
- [28] D. Box et al. web services eventing (ws-eventing). <http://www.w3.org/Submission/WS-Eventing/>. W3C Member Submission.
- [29] SensorML parser and processing engine. "<http://vast.uah.edu/SensorML/>".
- [30] ZigBee alliance. <http://www.zigbee.org/>.