

Received July 14, 2019, accepted August 2, 2019, date of publication August 13, 2019, date of current version August 28, 2019.

Digital Object Identifier 10.1109/ACCESS.2019.2934982

Toward High Accuracy Positioning in 5G via Passive Synchronization of Base Stations Using Thermally-Insensitive Optical Fibers

WENWU ZHU^{1,2}, (Student Member, IEEE), ERIC R. NUMKAM FOKOUA¹, YONG CHEN¹, THOMAS D. BRADLEY¹, SEYED REZA SANDOGHCHI¹, (Member, IEEE), MENG DING¹, (Student Member, IEEE), GREGORY T. JASION¹, MARCO N. PETROVICH¹, (Senior Member, IEEE), FRANCESCO POLETTI¹, MINGSHAN ZHAO^{1,2}, (Member, IEEE), DAVID J. RICHARDSON¹, (Fellow, IEEE), AND RADAN SLAVÍK¹, (Senior Member, IEEE)

¹Optoelectronics Research Centre, University of Southampton, Southampton SO17 1BJ, U.K.

²School of Optoelectronic Engineering and Instrumentation Science, Dalian University of Technology, Dalian 116024, China

Corresponding authors: Mingshan Zhao (mszhao@dlut.edu.cn) and Radan Slavík (r.slavik@soton.ac.uk)

This work was supported in part by the UK EPSRC “Airguide Photonics” Programme under Grant EP/P030181/1. The work of W. Zhu was supported in part by the China Scholarship Council Studentship. The work of F. Poletti was supported in part by the ERC Lightpipe Project under Grant 682724. The work of R. Slavík was supported in part by the Royal Academy of Engineering Senior Research Fellowship. The data for this work is accessible through the University of Southampton Institutional Research Repository (<https://doi.org/10.5258/SOTON/D1036>).

ABSTRACT Positioning accuracy in 5G networks (achieved via techniques based on observed time difference of arrival (OTDoA)) is limited by the synchronization error between the cellular base stations. Here, we demonstrate that these base stations can be synchronized entirely passively through the use of emerging forms of hollow core fiber (HCF) as the data transmission medium in the 5G front-haul network. This is possible due to the excellent thermal stability of HCF which allows the synchronization error among cellular base stations to be reduced significantly as compared to systems based on standard single mode fibers. Reducing this synchronization error is necessary to meet the strict timing requirements envisaged for 5G networks. We analyze the polarization mode dispersion, chromatic dispersion, and thermal stability of the HCF and give suggestions on how to use the HCF to balance overall radio over fiber (RoF) link performance in 5G front-haul networks. In a proof of concept experiment we show that HCF links enable the positioning error (calculated with the OTDoA method) to be reduced down to the centimeter level even when subject to tens of degrees Celsius temperature variations. This represents a 20-fold improvement over standard single mode fiber systems which would require active compensation schemes to achieve similar levels of time synchronization accuracy.

INDEX TERMS 5G, positioning, synchronization, hollow core fiber.

I. INTRODUCTION

The fifth generation mobile networks (5G) will provide (as compared to 4G) greater bandwidth, 10 times larger data rates per user, 100 times more connected users, ultra-low latency, and high accuracy geographical positioning as a new service [2]. High positioning accuracy at the centimeter level will be instrumental for emerging applications such as autonomous driving, geographic routing, beam steering and reliable emergency rescue [3]–[6].

The associate editor coordinating the review of this article and approving it for publication was San-Liang Lee.

Positioning services are traditionally provided by global navigation satellite systems (GNSSs) like Global Positioning System (GPS), which can provide meter level positioning accuracy. Besides not being precise enough for the afore-mentioned applications, GNSSs need line of sight (LoS) conditions, which are easily compromised in severe weather conditions, indoors, or in urban environments. Additionally, for a mobile user or Internet of Things (IoT) applications, the time to the first fix (TTFF) typically takes tens of seconds [7]. Besides the unwanted time delay, this also consumes power, which is often a critical consideration,

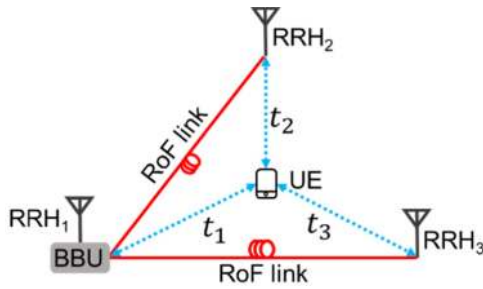

FIGURE 1. Configuration of front-haul network. UE: User equipment, BBU: Base-band unit, RRH_{*i*}: *i*-th remote radio head, RoF: Radio over fiber, t_i is the signal transmission time between UE and RRH_{*i*}.

e.g., in battery-operated equipment. In 4G, an alternative to GNSS has been adopted, the Observed Time Difference of Arrival (OTDoA) method. This method is based on measuring the time of arrival difference of a reference signal emitted from three nearby base stations (equipped with Remote Radio Heads, RRHs) at the User Equipment (UE) [8], see Figure 1. Its accuracy depends on the synchronization of the RRHs. For example, a 1 m positioning accuracy requires the time synchronization error to be below 2.5 ns [9]. Other methods to improve the positioning accuracy of 5G include: increasing the LTE bandwidth [10], use of optimized waveforms [11], [12] and use of fingerprints of deployed antennas [13]. However, it appears that some form of OTDoA is the most likely candidate to be implemented in 5G [14], [15].

Regarding current standardization efforts for 5G timing, no definitive consensus has yet emerged. For example, reference [16] suggests absolute time error across the entire network to be within ± 130 ns with the following relative timing error tolerances: ± 20 ns from the time server (grand-master), ± 100 ns from the time transportation (depending on the number of intermediate nodes), and ± 10 ns for the base stations. For the OTDoA based positioning services, only the last number (± 10 ns) is relevant, as the base stations/RRHs connected to the same Base-band Unit (BBU) are fed with the same timing signal. We expect that stricter timing standards may be adopted in due course, as the above-mentioned standardization proposal gives (as we show later) relatively limited performance in terms of positioning accuracy. Thus, we refer to the standardization proposal in [16] as ‘conservative’.

The time variations at the base stations/RRHs level come from:

- (i) stability of the Local Oscillator (e.g., $\pm 5 \sim \pm 50$ ppb for Oven Controlled Crystal Oscillator, OCXO) [17].
- (ii) power amplifiers (e.g., 20 dB gain change causes 6 ns propagation time difference) [18].
- (iii) signal processing element (e.g., 19 ns delay variation from FPGA’s IP core [19]).
- (iv) transmission medium (temperature stability of the fiber and coaxial cable, 8 ppm/K and 100 ppm/K respectively) [20], [21]. Although fiber is less sensitive, its length is significantly higher than for the electric connections.

These data suggest that the timing precision using current technologies will be in the tens of nanoseconds range, requiring improvements in all four above-mentioned parts of the system to reach the conservative ± 10 ns target. Further improvements still will be needed if a stricter standard (e.g., sub-nanosecond timing target) is to be met. We expect that each of the four timing error contributors mentioned above will need to be within ± 2 ns (conservative standard) and ± 500 ps or better (if a stricter standard is to be adopted), respectively.

In this paper, our discussion focuses on the aspects of the transmission medium (iv), i.e. time variations due to optical fibers that connect the RRHs with a Base-Band Unit (BBU), which form the so called front-haul network [22], Figure 1. In 5G, there will be a large number of RRHs, so their architecture will need to be very simple (to minimize cost), ideally receiving and transmitting signal without any additional hardware or electrical signal processing. This implies analog communications between the RRHs and the BBU using radio-over-fiber (RoF) and no use of GPS or IEEE Precision Time Protocols (PTP) (see for example [23]–[25]) for time and frequency synchronization. The interconnecting RoF links will be exposed to environmental variations, causing the signal propagation time through the optical fibers to vary significantly due to temperature fluctuations. For the positioning services, this timing variation will convert into a positioning error when using OTDoA based methods [26]. Outdoor temperature variation usually exceeds 10°C within one day, and in most countries also 30°C for one season, and over 60°C for one year [27], [28]. For a 1-km long single mode fiber (SMF-28) based RoF link, 60°C temperature change causes propagation time change of 2.4 ns (typical thermal propagation delay sensitivity of un-cabled SMF-28 is 40 ps/km/K [20], and is higher if the fiber is cabled fiber [29]). Considering two RRHs connected with the same BBU (Fig. 1) with 1-km long fibers, this gives maximum timing error of almost 5 ns (assuming un-cabled fiber) or more (for a cabled one). Un-cabled SMF-28 is in this scenario just at the edge of the conservative acceptable timing error of ± 2 ns. Thus, we can conclude that for the conservative timing requirements [16], SMF-28 fibers will be appropriate only for limited distances (e.g., up to 1 km fiber between a BBU and the most distant RRH) and limited temperature variations (e.g., $<30^\circ\text{C}$). However, for stricter timing standards or less benign conditions, SMF-28 cannot meet the requirements unless a compensation technique is used.

To the best of our knowledge, the synchronization error in 5G due to RoF links has not been studied before, though it has been considered in some other applications e.g. in metrology or within the square kilometer array telescope [30], [31]. In these applications, methods aiming at solving the synchronization problem have already been proposed, e.g. using active feedback control, or phase conjugate delivery [32], [33]. However, similar to the IEEE PTP, these methods need extra hardware and the correcting loop bandwidth is restricted by the signal round trip time. When

moving to the high frequency bands that 5G envisages, high frequency RF components will be needed for these synchronization techniques (e.g., frequency mixers, doublers and filters) which are likely to be associated with prohibitively high costs. Calibration of the RoF link based on temperature could reduce the time synchronization error, however, its efficiency would depend on the accuracy of the temperature measurement along the RoF link.

In this paper, we investigate how the 5G synchronization and positioning accuracy can be achieved in a simple, passive, and efficient way using new emerging optical fibers. These fibers, known as Hollow Core Fibers (HCF), offer excellent thermal stability of propagation delay [34], allowing for a drastic (~ 20 times) reduction of the synchronization error between different RRHs. As we show here, HCF-based RoF links allow for centimeter-level positioning accuracy using OTDoA, even when the temperature varies by as much as ± 30 °C or when the polarization of the light propagating through the fiber changes. This level of accuracy will allow for the synchronization of RRHs in an entirely passive way and meet the time error criterion proposed by the current standardization efforts and be even future-proof should stricter standards be adopted.

II. THERMAL SENSITIVITY OF OPTICAL FIBERS

As mentioned above, signal propagation time through standard optical fibers changes at a rate of 40 ps/km/K [29]. Considering a 1 km long fiber and a year-round temperature change of 60 °C, this gives a 2.4 ns time difference. We have shown that in HCF, this thermal sensitivity is reduced by almost 20 times to 2 ps/km/K [35], reducing the above-mentioned time variations from 2.4 ns down to 120 ps. This reduction is due to the fact that light propagates through an air-filled core rather than in a glass material. The flexibility of controlling the optical properties of these hollow-core fibers through structural design implies that this improved performance can be improved still. Indeed, we have shown that in a particular HCF geometry, the so called hollow core photonic bandgap fiber (HC-PBGF), this already-small sensitivity, (which is observed over most of HC-PBGF transmission window), can be further reduced down to zero or even made negative [34], [36], albeit over a small spectral range near the long wavelength edge of the fiber's transmission window. However, a fiber operating at this zero-sensitivity wavelength as opposed to the center of the window suffers from relatively higher attenuation, chromatic dispersion [36] and large differential properties between the polarization states of the fundamental mode [37]. This means that a careful consideration of the optimum operating point needs to be carried out for any given application. In particular, we need to evaluate whether the advantage of almost-zero thermal sensitivity (achieved at the edge of the transmission window) is not overshadowed by other transmission impairments that are generally stronger at the transmission window edge as compared to its central part (where thermal sensitivity is not zero, but still very small as compared to standard optical

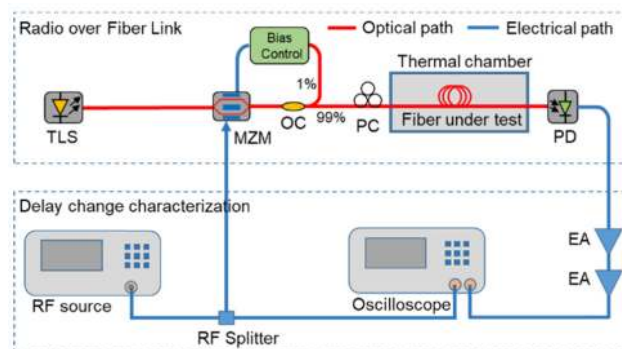

FIGURE 2. Experimental setup for analyzing the time delay performance of an RoF link. TLS: Tunable laser source, MZM: Mach-Zehnder modulator, OC: Optical coupler, PC: Polarization controller, PD: Photodiode, EA: Electrical amplifier.

fibers). Making such analysis for 5G front-haul applications is one of the objectives of our paper.

III. PERFORMANCE OF THE HC-PBGF LINK

Our experimental set-up (Figure 2) consists of an RoF link and means to accurately characterize the timing changes. The RoF link components include: a tunable laser source (TLS, Pure Photonics), 40-GHz LiNbO₃ amplitude modulator (MZM), polarization controller (PC), 1-km long HC-PBGF under test (detailed parameters can be found in [34]) or 1-km SMF-28 (for comparative purposes), and a photodiode (PD, Agilent 83440C). Our RoF link bandwidth was 40 GHz.

The polarization state of the light launched into the RoF fiber is adjusted via a polarization controller to allow us to study the impact of polarization on the timing performance of the fiber. This is to mimic a real-world environment in which polarization can change over time, due for example to thermal fluctuations, or random fiber bends, etc. The fiber under test was put into a thermal chamber to allow for emulation of environmental thermal changes. As RoF link delay is largely independent of the carrier frequency, we carried our timing measurement at a relatively low frequency of 7 GHz (limited by our real time oscilloscope). However, the timing performance (measured in seconds) should be identical for 5G frequencies, e.g., 28 GHz and 60 GHz. Our 7-GHz carrier was split into two with a splitter with one part used to drive the MZM operated at its quadrature transmission point whilst the other half was used as a reference signal sent to the oscilloscope. After the RoF link, the signal was amplified (with two electrical amplifiers (EAs)) and sent into the oscilloscope to measure its phase/delay change as the temperature and polarization states were modified.

We first characterized the polarization properties and chromatic dispersion (CD) of the HC-PBGF. The differential group delay (DGD) was measured by changing the polarization state (using PC) of the light before launching into the fiber under test and recording the maximum delay variations. This measurement was repeated for a range of wavelengths (over C+L bands) and temperatures. Polarization

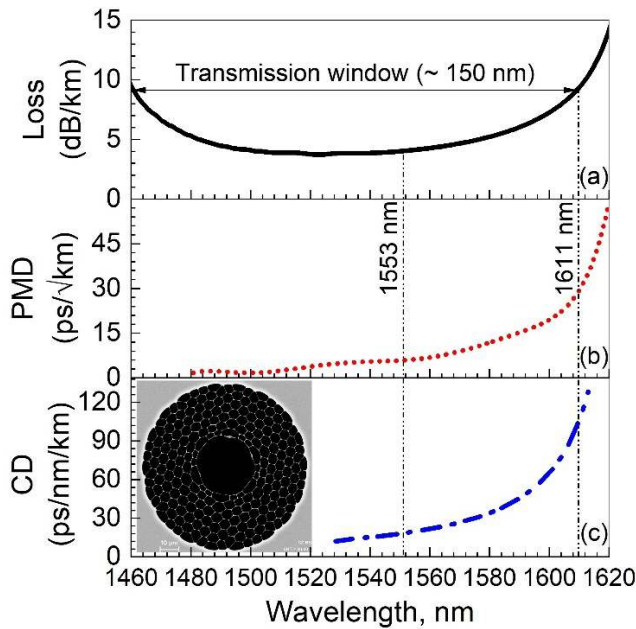

FIGURE 3. (a): Loss spectrum (solid black), (b): Polarization mode dispersion (red dash) and (c): Chromatic dispersion (blue dash dot) of the HC-PBGF. Inset: A scanning electron micrograph of the fiber end face.

mode dispersion (PMD) was then evaluated from averaged DGD data, Figure 3(b). We also measured PMD with the IEEE recommended fixed analyzer method [38], achieving good agreement of both methods. The propagation time of optical signals passing through the fiber changes with signal polarization/PMD. This means that if changes in the fiber’s environment (e.g. temperature, stresses or bends) cause frequency or polarization drift of the signal, this will contribute to the fiber’s perceived environmental sensitivity. The PMD characterizes the magnitude of these changes. The signal time of arrival variations may cause synchronization errors in timing-sensitive applications (e.g., positioning in 5G as discussed in this work).

We also measured the fiber CD using the same set-up as used for the PMD, measuring the group delay as a function of wavelength, and then calculating the CD from it, see Figure 3(c).

From Figure 3, we see that the PMD and CD both increase significantly at the long-wavelength edge of the HC-PBGF transmission window [37], which is where (as we have mentioned earlier) the lowest (zero) thermal sensitivity of the HC-PBGF occurs.

To measure the thermal properties of the fiber under test, the thermal chamber temperature was first kept at 58 °C for one hour and then it was turned off, causing the temperature to drop at a very slow rate of 2 °C/hour (Figure 4). This slow change helped to maintain a uniform distribution of the temperature inside the chamber. During the cooling down process, we kept recording the time delay changes and repeated the entire process several times for various TLS wavelengths (timing data were recorded from 50 °C to 30 °C to avoid the initial non-uniform temperature distribution and

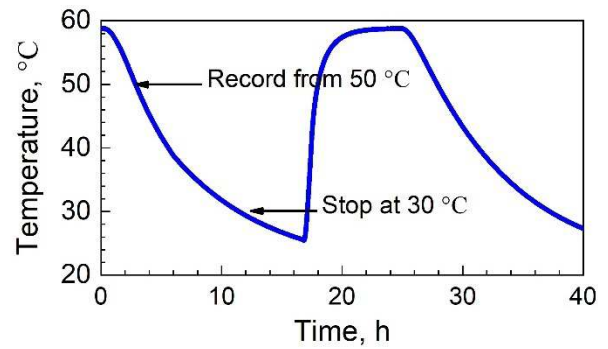

FIGURE 4. Temperature inside the thermal chamber over time.

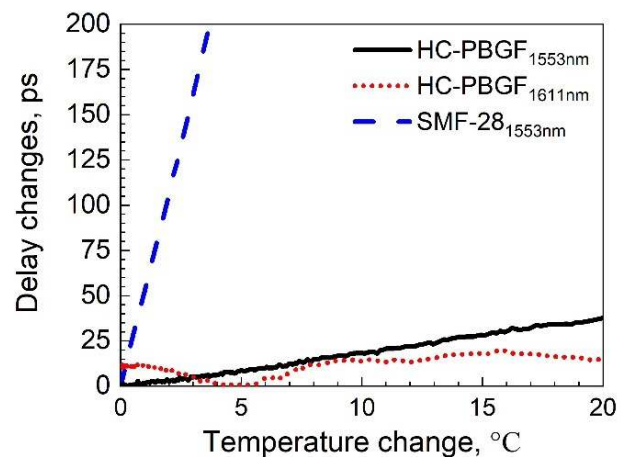

FIGURE 5. Delay changes with temperature for SMF-28 at 1553 nm (blue, dash) HC-PBGF at 1553 nm (black, solid) and HC-PBGF at 1611 nm (red, dot).

very slow final settling of the temperature). The thermal delay properties of the HC-PBGF at two different wavelengths (1553 nm and 1611 nm respectively) are shown in Figure 5. We evaluated the thermal delay at two wavelengths, 1553 and 1611 nm; 1553 nm is a wavelength near the center of the HC-PBGF transmission window (where loss, CD, and PMD are all relatively low), while 1611 nm is the wavelength at which our HC-PBGF is fully thermally insensitive [34]. At 1553 nm, the delay changes linearly by 38 ps for a temperature change of 20 °C. Considering the fiber length of 1 km, this corresponds to a rate of 1.9 ps/km/K, which is typical for hollow core fibers [35], [39], and is more than 20 times smaller than for SMF-28 (measured to be 43 ps/km/K and shown in Figure 5 for comparison). At 1611 nm, where we would expect no delay change with temperature (as it is the ‘zero thermal sensitivity point’), we observe that the delay changes by about ±10 ps without any obvious relationship with temperature. We believe this is due to the PMD that is significantly larger at the zero-sensitivity wavelength as compared to the center of the transmission window, Figure 3. If we look closely we can just observe small oscillations on the 1553 nm trace in Figure 5 of a similar form to the 1611 nm trace. We believe this to be due to the significantly lower PMD at 1553 nm. The origin of these oscillations is in temperature induced changes in PMD, and hence the

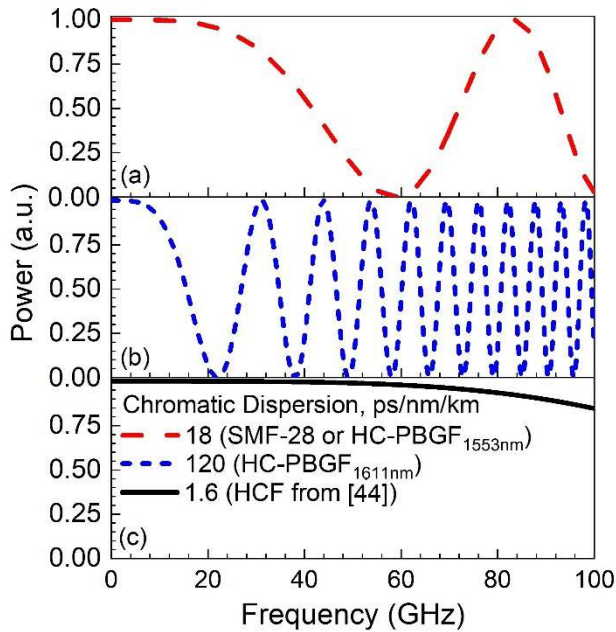

FIGURE 6. CD-induced power fading for (a): 1-km long SMF-28 and HC-PBGF at 1553 nm (red, dash), (b): HC-PBGF at 1611 nm (blue, short dash) and (c): Considering HCF from [44] (black, solid).

polarization evolution of signal light propagating through the relatively long length of HC-PBGF, and this in turn impacts the associated propagation delay.

Another possible origin for this variation may be the thermally-induced change of polarization state of the input signal launched into the HC-PBGF. If this happens, the propagation time through the fiber will change as a result of the PMD. As we see in Figure 5, operating the HC-PBGF over a temperature range of 20 °C at 1553 nm gives about a timing stability twice worse than at 1611 nm. It is worth mentioning that the PMD in HC-PBGFs results from small structural imperfections [37], [40] and thus could be significantly improved in due course with realistic improvements in fiber manufacturing processes, promising significantly better thermal performance at the zero-sensitivity point in due course.

For a practical RoF link, besides the signal delay properties, the CD has also to be considered, as it causes signal fading [41]. The RF power fading due to the dispersion is calculated from

$$P \propto \cos^2\left(\frac{\pi LD\lambda^2 f^2}{c}\right) \quad (1)$$

where L is the length of the fiber, D is the value of CD, λ is the wavelength, f is the frequency of the RF signal and c is the speed of the light in vacuum.

At 1611 nm, we measured $D_{1611} = 120$ ps/nm/km, while at 1553 nm, $D_{1553} = 18$ ps/nm/km, which is actually very close to the CD of SMF-28. The RF power calculated using Eq. (1) as a function of the carrier frequency is plotted in Figure 6. As we can see, the CD of HC-PBGF operating at the zero sensitivity point (1611 nm) is too high for 5G frequencies for the fiber lengths used (1 km). For operation at 1553 nm,

the RF power decreases by less than 3 dB at 40 GHz, similarly with for SMF-28, which is sufficient for most, but not all frequencies of interest in 5G.

To increase the RoF operation frequency or reach, a fiber with lower CD must be used. For standard optical fibers, lower dispersion is likely to introduce non-linear signal distortion due to the fiber nonlinearity [42]. This is very different in HCFs, where the fiber nonlinearity is approximately three orders of magnitude smaller and consequently they can be operated at zero (or close-to-zero) CD without any (non-linear) signal distortion [43]. Interestingly, newly emerging and rapidly improving anti-resonant type HCFs (ARFs), can be designed to have very low level of CD over a very large spectral window (e.g. < 2 ps/nm/km over 1000 nm [44], [45]), effectively eliminating CD-induced power fading in 5G front-haul networks, even for frequencies of 60 GHz and distances in excess of 1 km (black solid curve in Figure 6). Such fibers are extremely promising, having recently demonstrated lowest ever attenuation of 1.3 dB/km for any HCF reported to date [46], making them very attractive for RoF applications over longer distances than considered here. Unlike in PBGFs, the thermal sensitivity of ARF is limited by the thermal expansion of the silica glass from which they are made and cannot be completely eliminated. However, this residual thermal sensitivity remains 20 times lower than that of SMF-28 i.e. 2 ps/km/K.

To conclude, for 5G RoF links, HCFs with low CD (< 2 ps/nm/km) and low thermal sensitivity (< 2 ps/km/K) represent an ideal choice of transmission fiber, surpassing SMF-28 significantly in timing stability (> 20 times) and CD-induced fading, while not suffering from any fiber-induced non-linear signal distortion.

IV. POSITIONING PERFORMANCE

Finally, we have analyzed the potential positioning accuracies based on the measured thermal and polarization properties of the HC-PBGF we had available for this study, and for SMF-28 as a comparison.

We used the standard OTDoA method for calculating the UE position, in which the UE measures the time of arrival of signals received from at least three base stations or RRHs. The time difference from any two times of arrival determines a hyperbola, and the intersection of two hyperbolas ($T_{1,2} = T_1 - T_2$ and $T_{1,3} = T_1 - T_3$) determines the UE position (x_t, y_t) [9].

Due to the synchronization error between these stations, the UE measured time difference can be expressed as:

$$\Delta T_{1,i} = \frac{\sqrt{(x_t - x_i)^2 + (y_t - y_i)^2}}{c} - \frac{\sqrt{(x_t - x_1)^2 + (y_t - y_1)^2}}{c} + (T_i - T_1) \quad (2)$$

where $\Delta T_{1,i}$ is the time difference between the reference RRH₁ and the i-th RRH measured by UE, (x_i, y_i) is the

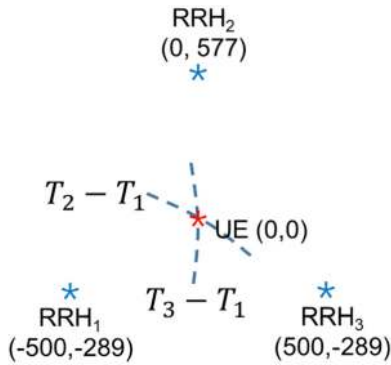

FIGURE 7. OTDoA positioning method.

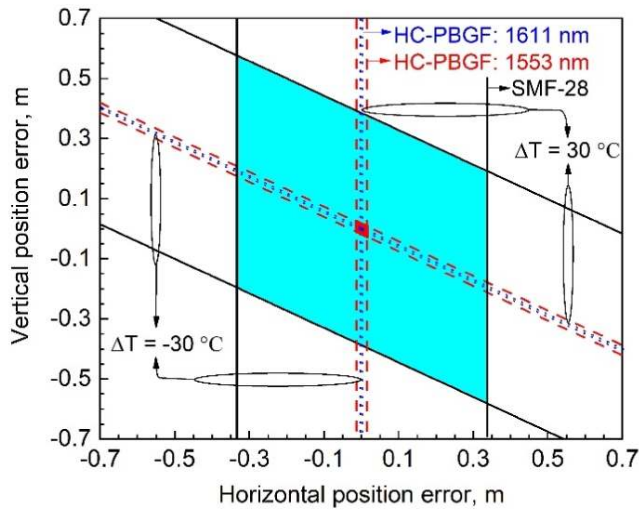

FIGURE 8. Positioning error boundary plotted based on $\pm 30^\circ\text{C}$ temperature variations. Dashed red lines show the positioning performance of HC-PBGF working at 1553 nm, blue dotted lines show HC-PBGF working at 1611 nm, and black solid lines show SMF-28. Blue, red and light blue regions are the possible calculated UE position for a temperature change within $\pm 30^\circ\text{C}$.

coordinates of the i -th RRH, and $T_i - T_1$ is the fixed delay plus the additional synchronization error between two RRHs.

To calculate the positioning error, we made the following assumption: the distance between any two RRHs is 1 km, the RoF links are 1.5 km long (to account for the fact that the fibers connecting RRHs are always longer than the distance between them) and the UE is at the center of the three RRHs. The coordinates of the UE and three RRHs are given in Figure 7. Assuming that both RoF links experience a year-round temperature change of $\pm 30^\circ\text{C}$, which gives a baseline to evaluate the positioning performance under any other temperature fluctuation, this temperature change will result in a synchronization error which in turn will lead to a positioning error.

Figure 8 shows the positioning error calculated using Eq. (2), considering the HC-PBGF and SMF-28 properties shown in Figure 5, the temperature induced synchronization error and the network topology described in Figure 7. When the RRHs are connected with SMF-28, the maximum synchronization error is ± 2 ns, corresponding to a positioning

TABLE 1. Performance comparison of different fibers and working conditions.

	SMF-28 1553nm	Hollow Core PBGF 1611 nm	Hollow Core PBGF 1553 nm	Hollow Core ARF [44] - [46]
Thermal delay sensitivity (ps/km/K)	43	0	1.9	~ 2 (expected)
PMD (ps $\sqrt{\text{km}}$)	0.06 [47]	22 \dagger 1.2 \ddagger	5 \dagger <0.2 \ddagger	--
CD (ps/nm/km)	17	120	0-18	<2
Optical loss (dB/km)	0.2	9	4.5	1.3
RF power penalty	Medium	High	Medium	Low
Positioning error ($\pm 30^\circ\text{C}$, mm)	± 700	± 4	± 30	± 30

\dagger measured value for the fiber used in this manuscript,

\ddagger predicted value considering improved fiber design and fabrication [37].

error of ± 700 mm. When using the HC-PBGF at 1553 nm, the synchronization error reduces to less than ± 90 ps, and the corresponding maximum positioning error is ± 30 mm. For operation at 1611 nm, the maximum positioning error was further reduced to ± 4 mm, with this error resulting from change in the polarization state of the light/PMD. The overall performance comparison is shown in Table 1. Considering all the aspects (PMD, CD, RF power penalty, and insertion loss) HC-PBGF working at the center of its transmission window is currently the best choice, although the emerging ARFs would give even better performance.

V. CONCLUSION

We have analyzed the thermal and PMD properties of HC-PBGF relevant to time synchronization in a 5G fiber front haul network. The overall best performance was achieved when operating the HC-PBGF at the center of its transmission window, where the thermal sensitivity of the propagation delay is more than 20 times lower than for SMF-28, reducing the year-round timing error in 5G network (where the distance between base stations are typically considered to be < 1 km) from ± 2 ns to ± 90 ps. The value of ± 2 ns is at the limit of what is required for conservative 5G timing proposals and would give very tight margins on the timing performance of the electronics/processing parts of the system. The eventual stricter 5G timing proposals cannot be met with SMF-28 unless some active compensation is employed, but are achievable with HC-PBGFs.

Timing errors of the order of ± 2 ns (SMF-28) and ± 90 ps (HC-PBGF) correspond to a positioning error of ± 700 mm and ± 30 mm respectively. Clearly, the performance given by HC-PBGF is essential for applications like autonomous vehicles navigation or indoor localization. [6], suggesting stricter timing standards than those proposed in [16] are to be expected for 5G networks.

It is worth mentioning that the influence of fiber cabling to the timing performance needs to be also studied, as current cabling solutions are known to degrade the fiber timing performance.

Newly emerging HCFs (e.g., ARFs) are expected to give further improvement in performance, in particular in terms of chromatic dispersion and loss.

The excellent thermal stability of HCFs relevant for time synchronization is further complemented by three of its other key properties relevant to 5G front haul networks. These are the low latency (signals propagate about 50% faster in HCFs as compared to SMF-28 [48]), the very low non-linearity, and finally the very low chromatic dispersion. The latter two properties allow for operation at very high carrier frequencies (e.g., 60 - 100 GHz) without chromatic-dispersion-induced signal fading or nonlinear signal distortion.

REFERENCES

- [1] *Study on Scenarios and Requirements for Next Generation Access Technologies (Release 15)*, document TR 38.913, 3GPP, Jul. 2018. [Online]. Available: <https://www.3gpp.org/DynaReport/38913.htm>
- [2] A. Osseiran, F. Boccardi, V. Braun, K. Kusume, P. Marsch, M. Maternia, O. Queseth, M. Schellmann, H. Schotten, H. Taoka, H. Tullberg, M. A. Uusitalo, B. Timus, and M. Fallgren, "Scenarios for 5G mobile and wireless communications: The vision of the METIS project," *IEEE Commun. Mag.*, vol. 52, no. 5, pp. 26–35, May 2014.
- [3] P. Kela, M. Costa, J. Turkka, M. Koivisto, J. Werner, A. Hakkarainen, M. Valkama, R. Jantti, and K. Leppanen, "Location based beamforming in 5G ultra-dense networks," in *Proc. IEEE 84th Veh. Technol. Conf. (VTC-Fall)*, Sep. 2016, pp. 1–7.
- [4] J. Rantakokko, J. Rydell, P. Strömbäck, P. Händel, J. Callmer, D. Törnqvist, F. Gustafsson, M. Jobs, and M. Grudén, "Accurate and reliable soldier and first responder indoor positioning: Multisensor systems and cooperative localization," *IEEE Wireless Commun.*, vol. 18, no. 2, pp. 10–18, Apr. 2011.
- [5] I. Skog and P. Handel, "In-car positioning and navigation technologies—A survey," *IEEE Trans. Intell. Transp. Syst.*, vol. 10, no. 1, pp. 4–21, Mar. 2009.
- [6] M. Schreiber, C. Knöppel, and U. Franke, "LaneLoc: Lane marking based localization using highly accurate maps," in *Proc. IEEE Intell. Vehicles Symp. (IV)*, Jun. 2013, pp. 449–454.
- [7] P. V. W. Loomis, R. Eschenbach, P. Braisted, and C. Lau, "Reduction of time to first fix in an SATPS receiver," Google Patent 5917444 A, Jun. 29, 1999.
- [8] J. Medbo, I. Siomina, A. Kangas, and J. Furuskog, "Propagation channel impact on LTE positioning accuracy: A study based on real measurements of observed time difference of arrival," in *Proc. IEEE 20th Int. Symp. Pers., Indoor Mobile Radio Commun.*, Sep. 2009, pp. 2213–2217.
- [9] S. Fischer, "Observed time difference of arrival (OTDOA) positioning in 3GPP LTE," Qualcomm, San Diego, CA, USA, White Paper 1.1, 2014, pp. 1–62.
- [10] H. Wymeersch, G. Seco-Granados, G. Destino, D. Dardari, and F. Tufvesson, "5G mmWave positioning for vehicular networks," *IEEE Wireless Commun.*, vol. 24, no. 6, pp. 80–86, Dec. 2017.
- [11] A. Dammann, T. Jost, R. Raulefs, M. Walter, and S. Zhang, "Optimizing waveforms for positioning in 5G," in *Proc. IEEE 17th Int. Workshop Signal Process. Adv. Wireless Commun. (SPAWC)*, Jul. 2016, pp. 1–5.
- [12] F. Schaich, T. Wild, and Y. Chen, "Waveform contenders for 5G—Suitability for short packet and low latency transmissions," in *Proc. IEEE 79th Veh. Technol. Conf. (VTC Spring)*, May 2014, pp. 1–5.
- [13] V. Savic and E. G. Larsson, "Fingerprinting-based positioning in distributed massive MIMO systems," in *Proc. IEEE 82nd Veh. Technol. Conf.*, Sep. 2015, pp. 1–5.
- [14] *Study on Indoor Positioning Enhancements for UTRA and LTE (Release 13)*, document TR 37.857, 3GPP, 2016. [Online]. Available: <https://portal.3gpp.org/desktopmodules/Specifications/SpecificationDetails.aspx?specificationId=2629>
- [15] Z. Chaloupka, "Technology and standardization gaps for high accuracy positioning in 5G," *IEEE Commun. Standards Mag.*, vol. 1, no. 1, pp. 59–65, Mar. 2017.
- [16] H. Li, L. Han, R. Duan, and G. M. Garner, "Analysis of the synchronization requirements of 5G and corresponding solutions," *IEEE Commun. Standards Mag.*, vol. 1, no. 1, pp. 52–58, Mar. 2017.
- [17] SiTime. (2018). *SiTime Emerald OCXO Product*. [Online]. Available: <https://www.sitime.com/sites/default/files/gated/Emerald-OCXO-Product-Brief.pdf>
- [18] R. Exel, G. Gaderer, and P. Loschmidt, "Localisation of wireless LAN nodes using accurate TDoA measurements," in *Proc. IEEE Wireless Commun. Netw. Conf.*, Apr. 2010, pp. 1–6.
- [19] J. Zou, J.-P. Elbers, R. Veisllari, J. B. Braute, M. Fontaine, S. Bjørnstad, and P. Ritoša, "Field-trial evaluation of low-latency and timing-accurate 100G Ethernet aggregator for converged mobile X-haul," in *Proc. Eur. Conf. Opt. Commun. (ECOC)*, Sep. 2018, pp. 1–3.
- [20] V. Dangui, H. K. Kim, M. J. F. Dignonnet, and G. S. Kino, "Phase sensitivity to temperature of the fundamental mode in air-guiding photonic-bandgap fibers," *Opt. Express*, vol. 13, no. 18, pp. 6669–6684, 2005.
- [21] K. Czuba and D. Sikora, "Temperature stability of coaxial cables," *Acta Phys. Polonica A*, vol. 119, no. 4, pp. 553–557, 2011.
- [22] C.-L. I. C. Rowell, S. Han, Z. Xu, G. Li, and Z. Pan, "Toward green and soft: A 5G perspective," *IEEE Commun. Mag.*, vol. 52, no. 2, pp. 66–73, Feb. 2014.
- [23] M. Koivisto, M. Costa, J. Werner, K. Heiska, J. Talvitie, K. Leppänen, V. Koivunen, and M. Valkama, "Joint device positioning and clock synchronization in 5G ultra-dense networks," *IEEE Trans. Wireless Commun.*, vol. 16, no. 5, pp. 2866–2881, May 2017.
- [24] G. Berardinelli, F. M. L. Tavares, O. Tirkkonen, T. B. Sorensen, and P. Mogensen, "Distributed initial synchronization for 5G small cells," in *Proc. IEEE 79th Veh. Technol. Conf. (VTC Spring)*, May 2014, pp. 1–5.
- [25] L. Gavrilovska, V. Rakovic, and V. Atanasovski, "Visions towards 5G: Technical requirements and potential enablers," *Wireless Pers. Commun.*, vol. 87, no. 3, pp. 731–757, Apr. 2016.
- [26] B. H. Chen, J. A. Lee, and W. M. MacDonald, "Method and apparatus for UE positioning in LTE networks," Google Patent 20110124347 A1, May 26, 2011.
- [27] W. Qian and X. Lin, "Regional trends in recent temperature indices in China," *Climate Res.*, vol. 27, no. 2, pp. 119–134, 2004.
- [28] P. D. Jones and D. Lister, "The development of monthly temperature series for Scotland and Northern Ireland," *Int. J. Climatol.*, vol. 24, no. 5, pp. 569–590, Apr. 2004.
- [29] M. Bousonville, M. K. Bock, M. Felber, T. Ladwig, T. Lamb, H. Schlarb, S. Schulz, C. Sydlo, S. Hunziker, P. Kownacki, and S. Jablonski, "New phase stable optical fiber," in *Proc. Beam Instrum. Workshop*, Apr. 2012, pp. 101–103.
- [30] G. Santarelli, F. Narbonneau, M. Lours, D. Chambon, S. Bize, A. Clairon, C. Daussy, O. Lopez, and M. E. Tobar, "High performance frequency dissemination for metrology applications with optical fibers," in *Proc. IEEE Int. Freq. Control Symp. Expo.*, Aug. 2005, pp. 925–927.
- [31] B. Wang, X. Zhu, C. Gao, Y. Bai, J. W. Dong, and L. J. Wang, "Square kilometre array telescope—Precision reference frequency synchronisation via 1f-2f dissemination," *Sci. Rep.*, vol. 5, Sep. 2015, Art. no. 13851.
- [32] B. Wang, C. Gao, W. L. Chen, J. Miao, X. Zhu, Y. Bai, J. W. Zhang, Y. Y. Feng, T. C. Li, and L. J. Wang, "Precise and continuous time and frequency synchronisation at the 5×10^{-19} accuracy level," *Sci. Rep.*, vol. 2, Aug. 2012, Art. no. 556.
- [33] F. Yin, A. Zhang, Y. Dai, T. Ren, K. Xu, J. Li, J. Lin, and G. Tang, "Phase-conjugation-based fast RF phase stabilization for fiber delivery," *Opt. Express*, vol. 22, no. 1, pp. 878–884, 2014.
- [34] U. S. Mutugala, E. R. N. Fokoua, Y. Chen, T. Bradley, S. R. Sandoghchi, G. T. Jasion, R. Curtis, M. N. Petrovich, F. Poletti, D. J. Richardson, and R. Slavik, "Hollow-core fibres for temperature-insensitive fibre optics and its demonstration in an Optoelectronic oscillator," *Sci. Rep.*, vol. 8, no. 1, Dec. 2018, Art. no. 18015.
- [35] R. Slavik, G. Marra, E. N. Fokoua, N. Baddela, N. V. Wheeler, M. Petrovich, F. Poletti, and D. J. Richardson, "Ultralow thermal sensitivity of phase and propagation delay in hollow core optical fibres," *Sci. Rep.*, vol. 5, Oct. 2015, Art. no. 15447.
- [36] E. N. Fokoua, M. N. Petrovich, T. Bradley, F. Poletti, D. J. Richardson, and R. Slavik, "How to make the propagation time through an optical fiber fully insensitive to temperature variations," *Optica*, vol. 4, no. 6, pp. 659–668, 2017.
- [37] E. N. Fokoua, W. Zhu, Y. Chen, S. R. Sandoghchi, T. D. Bradley, M. N. Petrovich, D. J. Richardson, F. Poletti, and R. Slavik, "Polarization effects on thermally stable latency in hollow-core photonic bandgap fibres," in *Proc. Opt. Netw. Commun. Conf. Exhib. (OFC)*, 2019, p. M3C-7.
- [38] N. Gisin, R. Passy, and J. P. von der Weid, "Definitions and measurements of polarization mode dispersion: Interferometric versus fixed analyzer methods," *IEEE Photon. Technol. Lett.*, vol. 6, no. 6, pp. 730–732, Jun. 1994.

- [39] U. S. Mutugala, J. Kim, T. D. Bradley, N. V. Wheeler, S. R. Sandoghchi, J. R. Hayes, E. N. Fokoua, F. Poletti, M. N. Petrovich, D. J. Richardson, and R. Slavík, "Optoelectronic oscillator incorporating hollow-core photonic bandgap fiber," *Opt. Lett.*, vol. 42, no. 13, pp. 2647–2650, 2017.
- [40] F. Poletti, N. G. R. Broderick, D. J. Richardson, and T. M. Monro, "The effect of core asymmetries on the polarization properties of hollow core photonic bandgap fibers," *Opt. Express*, vol. 13, no. 22, pp. 9115–9124, 2005.
- [41] S. A. Havstad, A. B. Sahin, O. H. Adamczyk, Y. Xie, and A. E. Willner, "Optical compensation for dispersion-induced coherent fading in optical transmission of double-sideband signals," Google Patent 6388785 B2, May 14, 2002.
- [42] K. S. Kim, R. H. Stolen, W. A. Reed, and K. W. Quoi, "Measurement of the nonlinear index of silica-core and dispersion-shifted fibers," *Opt. Lett.*, vol. 19, no. 4, pp. 257–259, 1994.
- [43] Z. Liu, B. Karanov, L. Galdino, J. R. Hayes, D. Lavery, K. Clark, K. Shi, D. J. Elson, B. C. Thomsen, M. N. Petrovich, D. J. Richardson, F. Poletti, R. Slavík, and P. Bayvel, "Nonlinearity-free coherent transmission in hollow-core antiresonant fiber," *J. Lightw. Technol.*, vol. 37, no. 3, pp. 909–916, Feb. 1, 2019.
- [44] J. R. Hayes, S. R. Sandoghchi, T. D. Bradley, Z. Liu, R. Slavík, M. A. Gouveia, N. V. Wheeler, G. Jasion, Y. Chen, E. N. Fokoua, M. N. Petrovich, D. J. Richardson, and F. Poletti, "Antiresonant hollow core fiber with an octave spanning bandwidth for short haul data communications," *J. Lightw. Technol.*, vol. 35, no. 3, pp. 437–442, Feb. 1, 2017.
- [45] Z. Liu, L. Galdino, J. R. Hayes, D. Lavery, B. Karanov, D. J. Elson, K. Shi, B. C. Thomsen, M. N. Petrovich, D. J. Richardson, F. Poletti, R. Slavík, and P. Bayvel, "Record high capacity (6.8 Tbit/s) WDM coherent transmission in hollow-core antiresonant fiber," in *Proc. Opt. Fiber Commun. Conf. Exhib. (OFC)*, May 2017, pp. 1–3.
- [46] T. Bradley, J. R. Hayes, Y. Chen, G. T. Jasion, S. R. Sandoghchi, R. Slavík, E. N. Fokoua, S. Bawn, H. Sakr, I. A. Davidson, A. Taranta, J. P. Thomas, M. N. Petrovich, D. J. Richardson, and F. Poletti, "Record low-loss 1.3dB/km data transmitting antiresonant hollow core fibre," in *Proc. Eur. Conf. Opt. Commun. (ECOC)*, Sep. 2018, pp. 1–3.
- [47] Corning. (2014). *Corning SMF-28e+ Optical Fiber*. [Online]. Available: <http://www.corning.com/worldwide/en/products/communication-networks/products/fiber/smf-28e-.html>
- [48] F. Poletti, N. V. Wheeler, M. N. Petrovich, N. Baddela, E. N. Fokoua, J. R. Hayes, D. R. Gray, Z. Li, R. Slavík, and D. J. Richardson, "Towards high-capacity fibre-optic communications at the speed of light in vacuum," *Nature Photon.*, vol. 7, no. 4, pp. 279–284, Mar. 2013.



YONG CHEN received the Ph.D. degree in physics from the University of Bath, in 2013. Soon after that, he joined the Optoelectronics Research Centre (ORC), University of Southampton, where he is currently a Senior Research Fellow, mainly working on the development of novel hollow core fibers. His research interests include design, fabrication, and characterization of microstructured optical fibers, postprocessing of conventional and microstructured fibers, mode converters, and nonlinear fiber optics.



THOMAS D. BRADLEY received the M.Phys. and Ph.D. degrees from the University of Bath, Bath, U.K., in 2009 and 2014, respectively. His Ph.D. degree and earlier career research has focused on the fabrication, characterization, and loading of gas species in both antiresonant and photonic bandgap hollow core fibers. In 2014, he joined the Optoelectronics Research Centre, Southampton, U.K., where he is currently a Postdoctoral Researcher with the microstructured optical fiber groups. His current research interests include the fabrication of low-loss antiresonant hollow core fibers, development of novel characterization tools for optical fibers, and gas filling in hollow core fibers. He received the Best Early Career Presentation Prize at the Engineering and Physical Sciences Research Council Manufacturing the Future Conference, in 2014.



SEYED REZA SANDOGHCHI received the bachelor's (Hons.) and M.Eng. degrees in telecommunication engineering from the Sadjad Institute of Higher Education, Mashhad, Iran, in 2005, and the University of Malaya, Kuala Lumpur, Malaysia, in 2011. He joined the Optoelectronics Research Centre, University of Southampton, in 2012, and was awarded the Ph.D. in the area of speciality optical fibers and microstructure optical fibers. He had significant role in the establishment of Integrated Lightwave Research Group and the fiber drawing tower at the University of Malaya. He has produced more than 90 publications among which one won the Best Student Paper Award at ECOC 2015, and two have been selected as Spotlight on Optics, in 2014 and 2015, respectively. He has been working with MOF Group at the ORC, since 2016, and has joined Lumenity Ltd., since 2018. He has a strong background and numerical modeling expertise in radio frequency communication devices, electromagnetism, optical fibers, and optical fiber test and measurement systems. His research interests include (among others) micro- and nano-structured optical waveguides, microscopy and nanoscopy, optical fiber test and measurement methods, and optical biosensing. He is currently working on microstructure optical fibers, where his main research activities include improving manufacturing techniques, developing interconnection methods, and designing and implementing test and measurement systems.



systems, hollow core fibers, and their applications.

WENWU ZHU received the Ph.D. degree in optical engineering from the School of Optoelectronic Engineering and Instrumentation Science, Dalian University of Technology, China, in 2019. From 2017 to 2018, he was with the Optoelectronics Research Centre, University of Southampton, as a Visiting Ph.D. Student. He is currently a TD Litho Process Engineer with Intel DMTM, working at the process development of 3D NAND memory chip. His research interests include radio over fiber



dielectric optical waveguides and their applications.

ERIC R. NUMKAM FOKOUA received the B.Sc. degree in microelectronics from Nankai University, Tianjin, China, in 2008, the M.Sc. degrees in photonics from the Universities of St. Andrews, Scotland, and Ghent, Belgium, in 2010. Having joined the Optoelectronics Research Centre soon after, he received the Ph.D. degree in optoelectronics, in 2014, for the work on the numerical modeling of hollow core photonics bandgap fibers. His research interests include numerical simulations of



MENG DING was born in Henan, China, in 1991. He received the B.S. degree from the Huazhong University of Science and Technology, Wuhan, China, in 2013, and the M.S. degree from the Shanghai Institute of Optics and Fine Mechanics, Chinese Academy of Sciences, Shanghai, China, in 2017. He is currently pursuing the Ph.D. degree with the Optoelectronic Research Centre, University of Southampton, Southampton, U.K. His research interests include hollow-core fibers and their applications.



fabrication process of hollow microstructured optical fibers.

GREGORY T. JASION received the M.Eng. degree in aerospace engineering and the Ph.D. degree from the University of Southampton, Southampton, U.K. He is currently a Royal Academy of Engineering Research Fellow with the University of Southampton. He specializes in the field of multiphase flow with an emphasis on computational modeling. These interests brought him to the Optoelectronics Research Centre to develop fluid dynamics models to understand and improve the



MINGSHAN ZHAO received the Ph.D. degree in electronic engineering from Ghent University, Belgium, in 2003. He is currently a Professor with the School of Optoelectronic Engineering and Instrumentation Science, Dalian University of Technology (DUT), Dalian, China, where he leads the Photonics Research Center. His current research interests include microwave photonic components and systems, polymer-based photonic integration for optical communication, and optical sensing.



Prize of the Society of Glass Technology, U.K., for his work on chalcogenide fibers. Since 2003, he has been working on silica microstructured fibers. He is currently a Professor with the ORC and a member of the EPSRC Centre for Innovative Manufacturing in Photonics. His research interests include the development of novel fiber structures, including photonic bandgap, antiresonant, highly nonlinear, dispersion tailored fibers and their application in telecommunications, gas sensing, and power delivery. He is a Senior Member of the Optical Society of America, has coauthored more than 190 publications in journals and conference proceedings, and is a frequent invited speaker at international conferences and meetings. He serves in the technical program committee of the IEEE Sensors conference and is an Associate Editor of the IEEE SENSORS JOURNAL.

MARCO N. PETROVICH (M'11–SM'12) received the Laurea degree in physics from the University of Padua, Padua, Italy, in 1998, and the Ph.D. degree in optoelectronics engineering from the University of Southampton, Southampton, U.K., in 2003. He joined the Optoelectronics Research Centre (ORC), in 1999, as a recipient of a prestigious Ph.D. studentship funded by the Pirelli Cables. He has been involved in multiple aspects of fiber fabrication. In 2001, he received the A.E. Owen



published more than 1000 conference and journal papers and produced more than 20 patents. His current research interests include among others: optical fiber communications, microstructured optical fibers, and pulsed high-power fiber lasers. He received the Royal Society University Fellowship, in 1991, in recognition of his pioneering work on short-pulsed fiber lasers. He is a Fellow of the OSA and IET. He became a Fellow of the Royal Academy of Engineering, in 2009, and a Fellow of the Royal Society, in 2018.

DAVID J. RICHARDSON (F'14) received the B.Sc. and Ph.D. degrees in fundamental physics from Sussex University, Brighton, U.K., in 1985 and 1989, respectively. He joined the Optoelectronics Research Centre (ORC), Southampton University, Southampton, U.K., in 1989. He is currently the Deputy Director of the ORC with responsibility for the ORC's fiber-related activities. He is a prominent figure in the international photonics community and has



coauthored more than 80 journals and 200 conference publications and produced four patents. His research interests include the design of photonic bandgap and antiresonant fibers, the development of fiber-optic characterization techniques, and the fabrication of non-silica-based fibers and devices. He is the holder of the European Research Fellowship Consolidator Grant.

FRANCESCO POLETTI received the Laurea degree in electronics engineering from the University of Parma, Parma, Italy, and the Ph.D. degree from the Optoelectronics Research Centre (ORC), Southampton, U.K., in 2000 and 2007, respectively, where he is currently a Professor. He has worked for three years on optical network design at Marconi Communications and for more than ten years on the development of new generations of microstructured optical fibers at the ORC. He has



as a Post-doctoral Research Fellow. Since 2009, he has been with the Optoelectronics Research Centre, University of Southampton, U.K. His research interests include optical and optics-assisted signal processing, study of environmental sensitivity of optical fibers, and hollow-core optical fibers and their applications in telecommunications, metrology, and sensing. He is a Fellow Member of the Optical Society of America.

RADAN SLAVÍK (M'07–SM'07) received the M.Sc. and Ph.D. degrees in optics and optoelectronics from the Faculty of Mathematics and Physics, Charles University, Prague, Czechia, in 1996 and 2000, respectively, and the D.Sc. degree from the Academy of Sciences of the Czech Republic, in 2009. From 1995 to 2000 and from 2004 to 2009, he was with the Institute of Photonics and Electronics, Czech Academy of Sciences, Prague. From 2000 to 2003, he was with the Centre d'Optique, Photonique et Laser, Université Laval, QC, Canada, as a

...