

Santosh Kumar Sarkar

Trace Metals in a Tropical Mangrove Wetland

Chemical Speciation, Ecotoxicological
Relevance and Remedial Measures

 Springer

Trace Metals in a Tropical Mangrove Wetland

Santosh Kumar Sarkar

Trace Metals in a Tropical Mangrove Wetland

Chemical Speciation, Ecotoxicological Relevance and Remedial Measures

 Springer

Santosh Kumar Sarkar
Department of Marine Science
University of Calcutta
Calcutta, West Bengal
India

ISBN 978-981-10-2792-5 ISBN 978-981-10-2793-2 (eBook)
DOI 10.1007/978-981-10-2793-2

Library of Congress Control Number: 2017944178

© Springer Nature Singapore Pte Ltd. 2018

This work is subject to copyright. All rights are reserved by the Publisher, whether the whole or part of the material is concerned, specifically the rights of translation, reprinting, reuse of illustrations, recitation, broadcasting, reproduction on microfilms or in any other physical way, and transmission or information storage and retrieval, electronic adaptation, computer software, or by similar or dissimilar methodology now known or hereafter developed.

The use of general descriptive names, registered names, trademarks, service marks, etc. in this publication does not imply, even in the absence of a specific statement, that such names are exempt from the relevant protective laws and regulations and therefore free for general use.

The publisher, the authors and the editors are safe to assume that the advice and information in this book are believed to be true and accurate at the date of publication. Neither the publisher nor the authors or the editors give a warranty, express or implied, with respect to the material contained herein or for any errors or omissions that may have been made. The publisher remains neutral with regard to jurisdictional claims in published maps and institutional affiliations.

Printed on acid-free paper

This Springer imprint is published by Springer Nature
The registered company is Springer Nature Singapore Pte Ltd.
The registered company address is: 152 Beach Road, #21-01/04 Gateway East, Singapore 189721, Singapore

*Dedicated to my respected Gurudev
Bramhananda Tirthanath – who ignited
my quest for knowledge*

Foreword

Trace metal contamination in coastal regions, especially estuaries, is of global concern due to their toxicity, abundance, and persistence in the environment and subsequent accumulation in organisms. The author's knowledge and expertise on such emerging aspects have been reflected in the present book entitled, *Trace Metals in a Tropical Mangrove Wetland: Chemical Speciation, Ecotoxicological Relevance and Remedial Measures*. He has an intricate network and collaborative research program with globally – acclaimed scientists which have a certain reputation in this field of research. This is a well-conceived book which encompasses mainly the case studies of Sundarban mangrove wetland (a UNESCO World Heritage Site), an Anthropocene megadelta formed at the estuarine phase of Ganges estuary and Bay of Bengal.

The coastal regions of Sundarban are under severe stress due to intensive anthropogenic activities leading to elevated concentrations of trace metals/metalloids in biotic and abiotic matrices of the ecosystem. This comprehensive treatise is a timely approach to quantify spatiotemporal distributions and geochemical fractionation of metals and explore the degree of metal contamination and its environmental risks using contamination indices and sediment quality guidelines (SQGs). Substantial data were collected through extensive and systematic field studies in Sundarban conducted by the author and his research group and presented in succinct style. Various geochemical indices that have been discussed with practical examples, such as geoaccumulation index, enrichment factor to assess quantification of sediment pollution, and sediment quality guidelines (SQGs), provide useful information that can be easily communicated to local managers and decision-makers. Moreover, an attempt has also been made to present a detailed account of statistical tools and their applications in a lucid manner citing practical examples for the benefit of students. A detailed description of analytical instruments used for total metal and chemical speciation analyses has also been illustrated with supporting diagram & figures. The chemical speciation of trace metals is of great importance as the information provides sound information on the origin, mobilization, biological availability, and potential toxicity to various organisms. Furthermore, it demonstrates how mangrove plants could be used to detoxify metal – contaminated sites via phytoremediation.

I feel that the book is of paramount importance, with the intensive development of industrialization and rapid expansion of the urbanization economic boom in developing countries, including India. I sincerely hope that the book will influence trace metal pollution control measures and would provide a tool for effectively protecting the fragile wetland environment. Prof. Sarkar's effort to highlight the environmental problems in this stressed globally important mangrove environment is highly commendable. Furthermore, it demonstrates how mangrove plants could be used to detoxify contaminated sites via phytoremediation.

Soil- and Groundwater-Management
University of Wuppertal
Wuppertal, Germany

Jörg Rinklebe

Preface

Coastal regions at the continent–ocean interface are complex and dynamic environments due to physical, chemical, and biological interactions and extremely sensitive to natural and human-induced stresses. These productive zones have been largely affected by natural as well as anthropogenic activities producing inorganic and organic pollutants, leading to potential long-term negative impacts on human health and the ecosystem as a whole (Dou et al. 2013; Wang et al. 2015; Xu et al. 2015a). Trace metal, the ubiquitous inorganic pollutants, has received global attention due to its toxicity, and also its abilities for further accumulations and biomagnifications in successive trophic levels.

Intertidal sediments could be recognized as potential abiotic matrices of the coastal and estuarine environments which serve as the potential repository of trace metals and act as a reliable indicator of ecosystem degradation of the coastal environment. Trace metal contamination in coastal marine environments is posing an increasingly serious threat as they are resistant to biodegradation. To assess the environmental impact of polluted sediments, information on total concentrations alone is not sufficient because metals are present in different chemical forms in sediments (exchangeable, carbonate, reducible, oxidizable, residual). Only part of the metals present can be easily remobilized. Thus, the chemical form of metals (speciation) in the sediment is of great significance in determining their behavior in the environment and their transport and remobilization potential. However, there is lack of integrated information regarding sources, distribution, speciation of trace metal, and its ecotoxicological relevance in coastal and marine ecosystems.

Hence, the author has made a modest attempt to compile regional case studies on distribution and quantification of total trace metal(loid)s along with some selective topics of interest, such as acid-leachable trace metals, sequential extraction and speciation of metals in sediment as well as representative biota samples in Indian Sundarban mangrove wetland, the vulnerable Anthropocene megadelta. In addition, a chapter has been devoted to illustrate statistical evaluations of field data for calculating sediment quality indices for the benefit of the young researchers working in this relevant field. The wetland undergoes pronounced ecological changes due to discharges of untreated or semi-treated domestic and municipal sewage, agricultural runoff, and effluents from multifarious industries resulting in negative impact on estuary's geochemistry. The book has been composed of two main parts:

the first half deals with the distribution and characteristics of total and acid-leachable trace metals. The second half has been mainly dealt with the chemical speciation of selective trace metals in sediments and representative biota of Sundarban, a taxonomically diverse and biologically productive environment along with phytoremediation capacity of selected mangrove plants to reduce trace metal pollution. The comprehensive treatise in total trace metal and its speciation in sediments provides useful baseline information regarding trace metal contamination in this coastal environment which would be useful for adopting strategies for sustainable management of living and nonliving resources.

The reference book is accorded to serve both basic and advanced information for the policy makers, coastal zone managers, and large section of people involved in coastal research conservation and management. I think this would provide better understanding and stimulate greater interest in the topic metal pollution and educated public would come forward in taking dynamic role to reduce pollution as a whole. Constructive comments and suggestions for improvement of the text are gratefully appreciated.

Calcutta, India

Santosh Kumar Sarkar

Acknowledgments

I should acknowledge the generous support from the following academicians and researchers who have shared their knowledge and reviewed specific chapters of the book and provided me with their constructive suggestions and valuable comments: Drs. Jiang-Shiou Hwang of National Taiwan Ocean University; Simonetta Corsolini of the University of Siena, Italy; Krishna Das of the University of Liege, Belgium; Karla Pozo of Masaryk University, Czech Republic; Emmanoel V. Silva-Filho of the Fluminense Federal University, Brazil; Jason Kirby of the Commonwealth Scientific and Industrial Research Organisation (CSIRO), Australia; M. P. Jonathan of CIEMAD IPN, Mexico; M. N. V. Prasad of the University of Hyderabad, India; Rahul Kundu of Saurashtra University, India; Jayant Kumar Mishra of Pondicherry University, India; Dr. Mathammal Sudarshan of the Inter-University Consortium for DAE Facilities, Calcutta Centre, India; Dr. P. Raja of ICAR, Indian Institute of Soil and Water Conservation, India; and K. K. Satpathy of the Indira Gandhi Centre for Atomic Research (IGCAR), India. The incredible support and assistance rendered by my research students, Bhaskar Deb Choudhury, Ranju Choudhury, Dibyendu Rakshit, Soumita Mitra, and Priyanka Mondal, as well as by my daughter Prathama Sarkar for preparing the manuscript is greatly appreciated.

Finally, I would like to express my sincere gratitude to Dr. Mamta Kapila, Senior Editor of Springer (India) Pvt. Ltd. at Life Science and Biomedicine; Mr. KrishnaKumar, Project Manger – SPi Global Services; and Ashok Kumar, senior executive of Springer Nature for their keen interest, valuable suggestions, as well as technical assistance in the publication of the book. The book would not materialize without their constant encouragement, cooperation, and guidance. Last but not the least, I wish to thank my wife Manjushree Sarkar who tolerated my incessant work and extended her full support and cooperation in completing the work.

I sincerely hope this would provide greater understanding and stimulate greater interest in the topic “metal and its speciation.”

Contents

1	Introduction	1
1.1	Why Sediments Should Be Given Priority for Pollution Monitoring Program?	2
1.2	Sources of Trace Metal Contamination	4
1.2.1	Point and Nonpoint Sources of Pollution	5
1.3	Sediment Accumulation Rate	6
1.4	Definition and Significance for Metal Speciation	8
1.5	Impact of Multiple Stressors on Trace Metal Pollution	10
1.5.1	Impact of Anthropogenic Activities for Metal Enrichments	10
1.5.2	Interaction Between Climate Change and Dispersion of Pollutants	12
1.6	Conclusion	16
	References	17
2	Materials and Methods	27
2.1	Study Sites and Selection of Sampling Stations	27
2.2	Sampling Strategy and Preservation of Sediment Samples	34
2.3	Analytical Protocol	35
2.3.1	Instrumental Techniques in Environmental Chemical Analysis	35
2.3.2	Quality Assurance/Quality Control	49
2.4	Sediment Quality Assessment and Ecological Risk	50
2.4.1	Pollution Load Index (PLI)	50
2.4.2	Contamination Factor (CF)	51
2.4.3	Geoaccumulation Index (I_{geo})	53
2.4.4	Enrichment Factor	54
2.4.5	Potential Ecological Risk Index	56
2.4.6	Modified Degree of Contamination (mC_d)	58
2.4.7	Nemerow Pollution Load Index	60
2.4.8	Mean ERM Quotient (m-ERM-Q)	61
2.4.9	Mean PEL Quotient (m-PEL-Q)	62
2.4.10	Sediment Quality Guidelines (SQGs)	64

2.5	Statistical Analyses	65
2.5.1	Correlation Matrix	68
2.5.2	Principal Component Analysis (PCA)	68
2.5.3	Dendrogram	70
2.5.4	Factor Analysis	71
2.5.5	Analysis of Variance (ANOVA)	72
2.5.6	Box and Whisker Plot	73
2.6	Conclusion	75
	References	75
3	Trace Element Contamination in Surface Sediment of Sundarban Wetland	79
3.1	Introduction	80
3.2	Materials and Methods	81
3.2.1	Study Site	81
3.2.2	Sediment Collection and Pretreatment	82
3.2.3	Physicochemical Analysis of Sediments	82
3.2.4	Sample Digestion and Analytical Protocol	83
3.2.5	Assessment of Sediment Quality Guidelines (SQGs)	83
3.2.6	Assessment of Sediment Contamination and Ecological Risks	83
3.2.7	Statistical Analysis	85
3.3	Results and Discussion	85
3.3.1	Sediment Geochemical Characteristics	85
3.3.2	Distribution of Trace Elements in Sediments	86
3.3.3	Assessment of Element Toxicity with Empirical SQGs	89
3.3.4	Assessment of Sediment Contamination	90
3.3.5	Statistical Evaluation	91
3.4	Conclusion	96
	References	97
4	Total and Acid-Leachable Trace Metals in Surface Sediment of Sundarban Wetland and Adjacent Hooghly River Estuary	101
4.1	Introduction	102
4.2	Materials and Methods	103
4.2.1	Study Area and Sampling Sites	103
4.2.2	Collection and Preservation of Sediment Sample	103
4.2.3	Physicochemical Analysis of Sediments	104
4.2.4	Analytical Procedure	105
4.2.5	Parameters of Sediment Quality Assessment	106
4.2.6	Sediment Quality Guidelines (SQGs)	107
4.2.7	Statistical Analysis	108

4.3	Results and Discussion	108
4.3.1	Sediment Geochemical Characteristics	108
4.3.2	Total and Acid-Leachable Trace Metal (ALTM) Concentration	110
4.3.3	Bioavailability of Trace Metal Concentration	112
4.3.4	Evaluation of Sediment Contamination	113
4.3.5	Sediment Quality Guidelines (SQGs)	115
4.3.6	Statistical Analyses	115
4.3.7	Comparison of TM Concentration with Other Estuarine Regions	117
4.4	Conclusion	117
	References	121
5	Bioaccumulation of Trace Metals in Macrozoobenthos of Sundarban Wetland	125
5.1	Introduction	126
5.1.1	In Situ Biological Monitors	127
5.2	Methodology	128
5.2.1	Collection of Research Samples	128
5.2.2	Analytical Protocol	128
5.3	Results and Discussion	131
5.3.1	Sediment Geochemical Characteristics	131
5.3.2	Pattern of Trace Metal Accumulation in Macrozoobenthos	132
5.4	Conclusion	140
	References	141
6	Geochemical Speciation and Risk Assessment of Trace Metals in Sediments of Sundarban Wetland	145
6.1	Introduction	146
6.2	Significance of Sequential Extractions for Metal Speciation	148
6.2.1	Drawback of Sequential Extraction Technique	149
6.3	Materials and Methods	150
6.3.1	Sample Collection and Sediment Quality Analysis	150
6.3.2	Analytical Procedure	150
6.3.3	Statistical Analyses	153
6.4	Results and Discussion	153
6.4.1	Sediment Quality Characteristics	153
6.4.2	Metals Present in Total Concentration in Sediments	154
6.4.3	Geoaccumulation Index (I_{geo})	156
6.4.4	Comparison with Sediment Quality Guidelines	157
6.4.5	Speciation Patterns of Metals/Metalloids	160
6.4.6	Statistical Analyses and Interpretations	165
6.5	Conclusion	167
	References	168

7 Organotin Compounds in Surface Sediments of Sundarban Wetland and Adjacent Coastal Regions	173
7.1 Introduction	173
7.2 Methodology	175
7.2.1 Study Area and Sampling Design	175
7.2.2 Analytical Protocol	176
7.2.3 Statistical Analysis	177
7.3 Results and Discussion	177
7.3.1 Sediment Geochemistry	177
7.3.2 Levels of Butyltin Contamination	179
7.3.3 Ecotoxicological Concerns	183
7.3.4 Alternate Booster Biocides for TBT	183
7.4 Conclusion	184
References	184
8 Arsenic Speciation in Sediments and Representative Biota of Sundarban Wetland	189
8.1 Introduction	190
8.2 Experimental Design	192
8.2.1 Sampling Sites	192
8.2.2 Polychaete and Sediment Collection	192
8.2.3 Reagents and Standards	193
8.2.4 Total Digestion and Extraction of Sediments	193
8.2.5 Total Digestion and Extraction of Polychaetes	194
8.3 Instrumentation	195
8.3.1 Total Arsenic Analysis	195
8.4 Results and Discussion	196
8.4.1 Sediment Geochemistry	196
8.4.2 Arsenic in Sediments	197
8.4.3 Arsenic in Polychaetes	199
8.4.4 Arsenic in Shellfish and Finfish	203
8.5 Conclusion	204
References	205
9 Phytoremediation of Trace Metals by Mangrove Plants of Sundarban Wetland	209
9.1 Introduction	210
9.2 Techniques of Phytoremediation	212
9.2.1 Phytoextraction	212
9.2.2 Rhizofiltration	214
9.2.3 Phytovolatilization	214
9.2.4 Phytostabilization	215
9.2.5 Phytodegradation	215
9.2.6 Rhizodegradation/Phytostimulation	216

9.3	Advantages and Disadvantages of Phytoremediation	216
9.3.1	Advantages	216
9.3.2	Disadvantages	217
9.4	Important Criteria for Trace Metal Accumulation in Plants	218
9.5	Material and Methods	219
9.5.1	Description of the Study Sites	219
9.5.2	Sample Collection and Preservation	220
9.5.3	Analyses of Trace Metals in Sediments and Plants	220
9.5.4	Analysis by Scanning Electron Microscope (SEM)	221
9.5.5	Statistical Analyses	221
9.6	Results and Discussion	223
9.6.1	Sediment Geochemistry	223
9.6.2	Assessment of Sediment Quality Values	225
9.6.3	Sediment Quality Guidelines (SQGs)	228
9.6.4	Trace Metal Content in Mangrove Plants	229
9.6.5	Quantification of Phytoextraction Efficiency	232
9.6.6	Statistical Analyses	234
9.6.7	Assessment of Sediment Trace Metal Pollution	237
9.6.8	Sediment Quality Guidelines (SQGs)	238
9.7	Conclusion	239
	References	240

About the Author

Santosh Kumar Sarkar Entrusted as a Professor of Marine Science at the University of Calcutta, India and has over 30 years of research experience in marine and estuarine ecology, biology, and geochemistry. He has authored more than 80 peer-reviewed research papers and several book chapters and also edited a book titled “Environmental Management” (SCIYO). He acted as the principal investigator for 12 national research projects and 7 international collaborative research projects. He has been working in tropical and temperate marine and brackishwater ecosystems in diverse disciplines, namely, Marine biodiversity, speciation of metals, trace organics, impact of climate change on biota, bioactive substances present in marine organisms, Phytoremediation of heavy metals by mangrove plants and sediment toxicity due to silver nanoparticles. He has engaged in joint research work with renowned research institutes around the globe, namely, the Ruđer Bošković Institute, Croatia; University of Genoa and University of Milan, Italy; IPIMAR/INRB IP, Portugal; University of Edinburgh and British Geological Survey, UK; University of Wuppertal, Germany; CSIRO, Adelaide, Australia; Masaryk University, Czech Republic; and Fluminense Federal University, Brazil. He published two books namely, *Loricata Ciliate Tintinnids in a Tropical Mangrove Wetland: Diversity, Distribution and Impact of Climate Change* with Springer in 2014, and *Marine Organic Micropollutants: A Case Study of the Indian Sundarban Mangrove Wetland* with Springer, 2016.

Coastal regions are complex and dynamic environments of immense ecosystem services. These are equipped with high ecological diversity and critical economic importance and keep changing its shape and position due to water dynamics, mainly associated with waves, tides, winds, periodic storms, sea level change, geomorphological processes such as erosion and accretion. These may be considered as highly vulnerable to environmental changes and have been largely affected by anthropogenic activities (municipal sewage, industrial effluents, agricultural discharges and sewage runoff, natural resource exploitation). Trace element contamination is a serious threat to marine environment and received global attention due to its toxicity, non-degradability (persistence), abundance, subsequent bioaccumulation, and biomagnification through successive trophic levels. Intertidal sediments are potential abiotic matrices of the coastal and estuarine regimes which serve as the useful and potential sink for trace metals. When effluents containing trace metals enter the surface water, metals do not remain in soluble form for a long time and have a tendency to deposit in sediments. Thus, sediments are considered more reliable to assess the pollution status of marine environment.

Trace metal contamination of the environmental media has attracted global attention because of their important effects on marine ecology and other aspects of the marine environment. So far, 12 trace metal(loid)s have been recognized as priority pollutants, namely, As, Be, Cr, Cu, Cd, Pb, Hg, Ni, Se, Ag, Ti, and Zn (Protano et al. 2014; Li et al. 2015a, b). Mercury is considered as one of the “critical pollutants” (popularly recognized as “Nasty 9”) as it is extremely harmful to the health of the environment.

The presence of trace metals/metalloids in sediment is thus considered to pose potential threats to marine ecosystems because these are nonbiodegradable, persistent, and long biological half-lives for elimination from the body and thus can cause critical problems (Christophoridis et al. 2009; Bednarova et al. 2013; Lai et al.

2013; Lim et al. 2013). One of the main problems is the potential for the toxic trace metals (mercury, chromium) to bioaccumulate and biomagnify, and these processes can result in long-term impacts on human health and on marine ecosystems as a whole (Rainbow 2007; Wang and Rainbow 2008). Human activities concentrated in urban and industrial areas influence the distribution of toxic metals in coastal environments (Frignani and Belluci 2004; Lim et al. 2013).

Coastal and estuarine zones in India including West Bengal are getting contaminated with inorganic and organic contaminants, mainly by anthropogenic-derived processes, keeping pace with the intensive development of industrialization and rapid expansion of the urbanization. Trace metals discharged into coastal waters rapidly become associated with suspended particulate matter (SPM) and incorporated in sediments as a result of adsorption, hydrolysis, and co-precipitation, making coastal sediments the most potential sink for inorganic and organic pollutants (Huo et al. 2013). Trace metals in sediments interact with sediment matrix through different binding mechanisms, such as adsorption to mineral surfaces, association with carbonates, Fe/Mn oxyhydroxides, and organic matter. Moreover, they exhibit different environmental behaviors critically dependent on their chemical forms and/or interactions, thus influencing mobility, bioavailability, and potential toxicity to organisms (Castillo et al. 2013). Considering the above, the book attempts to explore in quantifying total metal and its speciation in intertidal sediments as well as representative biota in coastal regions of Sundarban mangrove wetland. This would critically examine evaluating processes of transport, deposition, and release of trace metals under changing environmental conditions which, in turn, are controlled by the physicochemical as well as biological characteristics.

1.1 Why Sediments Should Be Given Priority for Pollution Monitoring Program?

Sediment is a potential abiotic matrix, composed of detritus, inorganic, and organic particles, and is relatively heterogeneous in terms of its physicochemical and biological characteristics (Hakanson 1992). An important component of estuarine environment in the biogeochemical cycling of metals (Ding et al. 2009; Dong et al. 2012), they are considered as one of the potential sinks and sources of inorganic and organic contaminants, during changes in environmental conditions (such as redox potential, pH, and others) (Chapman et al. 2013; Gu et al. 2014; Jonge et al. 2012; Nielsen et al. 2010). Moreover, estuarine sediments are highly susceptible to pollution due to their physicochemical characteristics (Cheng et al. 2013; Hu et al. 2013). They work excellently as a metal reservoir, due to the capacity of holding more than 90% of metals in the aquatic environment (Camargo et al. 2015; Zahra et al. 2014), as the trace metals are integrated and amplified by sediments and the trapping and accumulation are mainly done by flocculation and adsorption

processes. In addition, they also act as a potential secondary source of metals which might be released back into water columns along with changed environmental conditions (Zahra et al. 2014; Wang et al. 2015).

Considering the above features, the case studies have given due emphasis exclusively on sediments for the following reasons:

- (a) Intertidal sediments are the most useful and potential abiotic matrix of the coastal environment and serve as the major sink (repository) source of trace metal(oids) including trace organics. Rapid assimilation of these pollutants into sediments occurs by various physicochemical processes such as oxidation, degradation, dispersion, dilution, and ocean currents. When effluents from industries/agriculture enriched with metals enter the surface water, these do not exist in soluble forms for a long period of time and have a tendency to deposit in bottom sediments (Zhao et al. 2014; Yang et al. 2016). Hence, sediments are considered as a key indicator of water pollution by a wide range of chemical contaminants and act as potential secondary sources to access the pollution status of coastal environment.
- (b) The historical records of contamination can be assessed from sediments accumulated over the years and could be recognized as fixators of contamination level. Monitoring of trace metal deposition in sediments provides a continuous pollution surveillance in a metal-stressed region. Sediment analysis could specify the perfect pollution status and subsequent controlling measures to be adopted for sustainable management of the environment (Bastami et al. 2015, 2016).
- (c) Substantial quantities of free metal ions are preserved in sediments, while a negligible fraction of metals is present in dissolved water. The concentration of dissolved metals is determined by solvent extraction using chelating agents, ammonium pyrrolidine dithiocarbamate (APDC), and methyl isobutyl ketone (MIBK), as a standard analytical method and subsequently measured by graphite furnace atomic absorption spectrophotometer (GF-AAS). The process is labor-intensive (reagent purification and sample processing) and time-consuming as it demands large sample volume (usually in liter scale).
- (d) Sediments in aquatic environments may either retain large metals or release them to the water column by various remobilization processes (such as biological and chemical properties). Sediment geochemical characteristics (textural properties, pH, organic carbon, and oxidation–reduction potential) are key factors controlling accumulation and availability of trace metals in sediments. Trace metals trapped by fine-grained sediment particles (e.g., clay and silt) form stable complex and finally deposited in the bottom. In case of exceedance of trace metal concentrations over safe limits, these can result in long-term adverse impact on the health of micro-, meio-, and macrobenthic organisms (Liu et al. 2016) and may even damage the ecosystem.
- (e) Sediment acts as a useful conservative component in comparison to water in which contamination levels are highly variable and dynamic. In contrast, sediment core perfectly restores and integrates the historical contamination

record in successive sediment strata, and the effects of anthropogenic stresses are reflected on accumulation processes. For this reason, sediments have been recognized as potential environmental indicators to identify and monitor contamination sources from its past record.

- (f) It is worth to refer that sediments are a food source for deposit-feeder organisms (e.g. bivalve, molluscs, polychaets, annelids etc.), and any toxic and harmful substances retained in them can be transmitted to aquatic species, finally affecting wild lives including humans through the food chain (Rosado et al. 2015). Sediments are absorbed by benthic organisms and bioaccumulate and biomagnify through food chain, resulting in fundamental alterations to ecosystems leading adverse impact on human health (Gu et al. 2012; Malferrari et al. 2009; Plette et al. 1999; Ribeiro et al. 2013; Teuchies et al. 2012). For all these reasons, the presence of contaminants in the sediments of aquatic ecosystems has become a major environmental problem (Chapman and Wang 2001; Sainz and Ruiz 2006).
- (g) This has been experimentally demonstrated that metal concentrations in the sediment are more sensitive than those in other materials (Mutia et al. 2012). Genetic identification of aqueous environmental DNA (eDNA) provides site occupancy inferences for rare aquatic macrofauna that are often easier to obtain than direct observations of organisms. This relative ease makes eDNA sampling a valuable tool for conservation biology. Recently, Turner et al. (2015) tested the hypothesis that eDNA is more concentrated in surficial sediments than in surface water by measuring the concentration of aqueous and sedimentary eDNA from an invasive fish, bigheaded Asian carp (*Hypophthalmichthys* spp.), in experimental ponds and natural rivers.

1.2 Sources of Trace Metal Contamination

Trace metals in coastal environments originate from both natural processes (such as the weathering, volcanic eruptions, and erosion of soils and rocks) and anthropogenic sources (including municipal wastes, industrial effluents, and hazardous wastes discharged from the riverine system), and they are continually introduced to coastal environments in river discharges, through the atmosphere, and in submarine groundwater discharges (SGD) (Hwang and Yang 2003; Çevik et al. 2009; Yuan et al. 2012). Trace metals released into coastal water rapidly bind to particulate matter, most of which settles and accumulates in coastal sediment before they reach the open ocean (Hedge et al. 2009; Lim et al. 2013; Ra et al. 2013). However, some trace metals can be remobilized by diagenesis in sediment or resupplied to the overlying seawater (Fichet et al. 1998; Cukrov et al. 2011; Ra et al. 2011).

Metals occur naturally in the soil environment from the pedogenetic processes of weathering of parent materials at levels that are regarded as trace ($<1000 \text{ mg kg}^{-1}$)

and rarely toxic (Kabata-Pendias and Pendias 2001; Pierzynski et al. 2000). Due to the disturbance and acceleration of nature's slowly occurring geochemical cycle of metals by man, most soils of rural and urban environments may accumulate one or more of the metals above defined background values high enough to cause risks to human health, plants, animals, ecosystems, or other media (D'Amore et al. 2005). The metals essentially become contaminants in the soil environments because (1) their rates of generation via man-made cycles are more rapid relative to natural ones, (2) they become transferred from mines to random environmental locations where higher potentials of direct exposure occur, (3) the concentrations of the metals in discarded products are relatively high compared to those in the receiving environment, and (4) the chemical form (species) in which a metal is found in the receiving environmental system may render it more bioavailable (D'Amore et al. 2005). Metals in the soil from anthropogenic sources tend to be more mobile, hence bioavailable than pedogenic or lithogenic ones (Kuo et al. 1983; Kaasalainen and Yli-Halla 2003). Metal-bearing solids at contaminated sites can originate from a wide variety of anthropogenic sources in the form of metal mine tailings, disposal of high metal wastes, leaded gasoline and lead-based paints, fertilizers in agricultural fields, animal manures, biosolids (sewage sludge), compost, organochlorine pesticides, coal combustion residues, petrochemicals, and atmospheric deposition (Basta et al. 2005; Khan et al. 2008; Zhang et al. 2010).

Trace metals enter into aquatic environments through atmospheric deposition, sewage outfalls, urban storm water, and agricultural and industrial runoff. Then, the metals are absorbed and preserved in sediment, which enriches organisms through the food chain (Cheng et al. 2013). Trace metals in the sediment may recycle into the water column via sediment resuspension, adsorption, and changing chemical conditions (Dong et al. 2012).

1.2.1 Point and Nonpoint Sources of Pollution

A point source of pollution is a single identifiable localized source of air, water, thermal, and sound pollution and has negligible extent. Compared to nonpoint source pollutants, point source pollutants are characteristically (1) easier to control, (2) more readily identifiable and measurable, and (3) generally more toxic. In mathematical modeling, these sources can usually be considered as a mathematical point to simplify analysis.

Nonpoint sources (NPSs) are the consequence of agricultural activities (e.g., irrigation and drainage, applications of pesticides and fertilizers, runoff and erosion), urban and industrial runoff, erosion related to construction, mining and forest harvesting activities, pesticide and fertilizer applications, atmospheric or aeolian deposition, livestock waste, and hydrologic modification (e.g., dams, diversions, channelization, overpumping of groundwater, siltation). Point sources include hazardous spills, underground storage tanks, storage piles of chemicals, mine-waste ponds, deep-well waste disposal, industrial or municipal waste outfalls, runoff, and leachate from municipal and hazardous waste dumpsites and septic tanks.

Compared to point source pollution, NPS pollution is more difficult for monitoring and controlling measures, as these originates from diverse diffusive sources, combining a large surface area. Characteristically, nonpoint source pollutants (1) are difficult or sometimes impossible to identify the source, (2) enter the environment over a broad area and sporadic timeframe, (3) are partially related to certain uncontrollable meteorological events and existing geographic/geomorphologic conditions, (4) have the potential for maintaining a relatively long active presence on the global ecosystem, and (5) may result in long-term, chronic (and endocrine) effects on human health and soil-aquatic degradation.

1.3 Sediment Accumulation Rate

All sediments are a mixture of particles from multiple sources. The accumulation rate and type of sediment are determined by the relative quantities of particles from each source that are deposited in each location. When dominated by biogenous particles, it is recognized as “biogenous sediments” and “lithogenous sediments” when dominated by fragments of rocks and minerals. Lithogenous particles are the dominant input to ocean sediment. Most lithogenic material is discharged to the oceans from land as relatively large particles and deposited near river mouths, estuaries, and wetlands. In frozen river delta, British Columbia, Canada, sediment accumulation rate in nearby regions ranges from about 100 cm per 1000 year up to extreme ranks such as 7 m per year.

Somewhat smaller but still larger quantities of lithogenic sediments are transported offshore getting deposited on continental shelves. Such sediments can also reach the deep ocean floor in areas where the continental shelves are narrow or as turbidities. Many continental shelves are areas of high biological productivity. Accordingly, sediment rates on the continental shelf and slope and within marginal seas (such as Mediterranean), are generally confined ~10 to 100 cm per 1000 year.

In the deep ocean remote from land, lithogenous inputs are much revealed, and biogenous materials, especially calcium carbonate, is dissolved because it can settle and be buried. Therefore, sedimentation ranks in the deep ocean basins are very low, approx 0.1 cm per 1000 years. Under highly productive areas or on shallow seamounts, or oceanic plateaus remote from land, the increased rate of sedimentation of biogenous material raises the sedimentation rate by about an order of magnitude, to approx 1 cm per 1000 years.

Two methods are generally recognized to determine sediment deposition and sediment accumulation rates, namely, (1) in situ sediment trap experiments, a complicated process exclusively applicable to calm water basin and (2) isotope method based on measurements of ^{210}Pb activities in sediment cores. The ^{210}Pb , a radiogenic (via ^{238}U and ^{222}Rn) and radioactive isotope with a half-life of 22.1 years, is a very powerful application to estimate the sedimentation chronology (age-date the deposition of layered materials of sediments) with high precision of a few years under favorable environmental conditions.

Sedimentation is a complex process undergoing certain irregular stages of particle transport, emplacement, removal, and subsequent preservation in the seabed with somewhat preservation of strata (McKee et al. 1983). This definition implies several successive stages of long sedimentation processes. The first stage is deposition defined as temporary emplacement from and preservation on the seabed and pertains to this relatively short time of sediment formation. Sediment accumulation requires longer period of time resulting particle deposition and removal, leading to the preservation of the strata. Particle removal may be due to several mechanisms, e.g., physical erosion, biological resuspension, and chemical dissolution (McKee et al. 1983).

Sediment accumulation rate can be perfectly determined by an isotope method based on the analyses of changes in ^{210}Pb activity in the sediment profile. Rate of sediment accumulation in marine environment has been a subject of research done by many workers (Nicholas 1989; Appleby and Oldfield 1992 and Appleby 1997). However, these are the most controversial issues resulting from application of diverse methodologies and interpretation of the results. Sediment accumulation rate has been an important criterion on many geochemical processes and significant for sustaining the benthic organisms in this environment, especially the seabed fauna (Musielak 1985; Appleby and Oldfield 1992 and Appleby 1997).

Sediment accumulation rate, mainly dominated by terrigenous sources, varies widely due to natural variability of the concerned complicated processes. This depends on a number of factors, viz., quantity and quality of sediment being deposited, distance from sediment source, intensity of biological processes (e.g., algal blooms, bioturbation activities by macrozoobenthos), seasonal phenomena (e.g., natural geohazards, storm surges, floods), geological seabed composition, depth of seabed, and intensity of hydrological and hydrodynamic conditions. Moreover, the sources and amount of sediment transported from land to sea by atmosphere may also be affected by the intensity of weathering, erosion, and degradation.

Sedimentation rate may largely affect the trace metal concentration in the sediments (except adsorption and desorption processes). In case the concentration of metals is constant, the high sedimentation rate would dilute the metal concentrations in sediments. In contrast, low sedimentation rate of particles would present a concentrating effect. As a matter of fact, the trend of metal concentration in the water column might be altered by rate of sedimentation.

Metals produced by human activities which enter into rivers and estuaries finally affect coastal marine systems. As the sediment acts as a sink for inorganic or organic pollutants including trace metals in the water environment, it can significantly influence the behavior and bioavailability of pollutants (Yu et al. 2012). Metals derived from atmospheric deposition, external river input, and endogenous sediment release will eventually be adsorbed onto sinking particles in the water column and then settle down into the sediment together with these particles (Niu et al. 2009; Tao et al. 2012; Zhuang and Gao 2013). Therefore, the pollution level of metals (contamination history) can usually be assessed by examining the metal concentration in the sediment (Qin et al. 2006). The concentration of metals in the

sediment would be determined mainly by two factors, namely, metal concentration in the water column and rate of particles sinking from the water column into the sediment (i.e., sedimentation rate). Metal concentration in the water column is focused on studying the adsorption and desorption process in the solid–liquid two-phase (Peng et al. 2009). Except the adsorption and desorption process, sedimentation rate, however, may substantially affect the metal concentration in the sediment. If the metal concentration in the water column is constant, the high sedimentation rate of particles would dilute the metal concentration in the sediment. In contrast, the low sedimentation rate of particles would result a contrast effect. As a matter of fact, tendency of metal concentration in the water column could be changed by the sedimentation rate.

One of the most promising methods for estimation of sedimentation rate on a time scale of 100–150 years is by means of ^{210}Pb , a naturally occurring radioisotope with a half-life of 22.3 years (Goldberg 1963; Oldfield and Appleby 1984). The ^{210}Pb method was initiated by Goldberg (1963), then applied to lake sediments by Krishnaswamy et al. (1971), and subsequently introduced to marine sediments by Koide et al. (1972). The accumulation rate of the sediment comprising a > 100-year period can be determined only by an isotope method based on the analyses of changes in ^{210}Pb activity in the sediment profile (Musielak 1985; Appleby and Oldfield 1992 and Appleby 1997). It has been very popular in estimating the sedimentation rate of marine sediments (e.g., Owen and Lee 2004; Szymtkiewicz and Zalewska 2014). Meanwhile, it is common practice in the published literature to use ^{137}Cs as an independent tracer to verify ^{210}Pb method (e.g., Robbins and Edgington 1975; Matsumoto 1987). There has been significant measurable bomb-derived ^{137}Cs in the environment since the 1950s and a distinct peak in 1963 (Matsumoto 1987; Ritchie and McHenry 1990; He et al. 1996; Japan Meteorological Agency 2001).

For Sundarban and Hooghly estuary, Banerjee et al. (2011) applied vertical distribution of ^{210}Pb to ascertain geochronological age to calculate the mass accumulation rates and historic trace element inputs and their variations. The sediment cores from selected locations of Sundarban mangroves and Hooghly estuary reveal a wide range in sedimentation rates ($3.0\text{--}4.5\text{ mm year}^{-1}$) and mass accumulation rates ($0.41\text{--}0.78\text{ g cm}^{-2}\text{ year}^{-1}$) reflecting their respective locations. At a specific site of Sundarban, radionuclide inventories imply that sediment is effectively focused, resulting in significantly elevated mass accumulation rates. This is mainly due to the frequent exposure to the tidal inundation and flocculation under high saline conditions.

1.4 Definition and Significance for Metal Speciation

Trace metal pollution of the aquatic ecosystems has significantly enriched in recent times mainly due to intensive anthropogenic activities as previously discussed. This would cause serious ecological and human health hazards due to bioaccumulation and biomagnifications in intricate food webs. However, the total metal

accumulation in sediments is insufficient approach to measure the adverse impact on the environment because heavy metals in sediment can be present in different chemical forms and have different degrees of bioavailability (Noronha-D'Mello and Nayak 2016). Hence, it is very crucial to quantify the mobility and bioavailability of the metal(loid)s, especially the toxic ones (e.g., Hg, Cr, As), which facilitates the mechanisms of uptake through cell membranes, intracellular distribution, and binding to cellular macromolecules (Beyersmann and Hartwig 2008). For example, several chemical forms of chromium are present, but only trivalent (Cr III) and hexavalent (Cr VI) chromium are stable enough and the later is much more toxic for both acute and chronic exposures. The toxicological difference between Cr III and Cr VI is very much related to their chemical characteristics, maintaining the stability, mobility, and bioavailability of these species in marine systems.

Speciation may be defined as either the process of identifying and quantifying the different defined species, forms, or phases present in a material or the description of the amounts and kinds of these species, forms, or phrases (Ure et al. 1993a, b). In IUPAC, Templeton et al. (2000) defined speciation analysis as the process leading to the identification and determination of the different chemical and physical forms of an element existing in a sample. Michalke (2003) defined speciation analysis as the analytical activity of identifying and measuring species. Le (1999) broadly defined chemical speciation as the identification and quantification of chemical species, their distribution and transformation in the environment, their toxicity, and their health effects. Speciation of a metal affects not only its toxicity but also its volatilization, photolysis, sorption, atmospheric deposition, acid/base equilibrium, polymerization, complexation, electron-transfer reactions, solubility and precipitation equilibrium, microbial transformations, and diffusivity (Bodek et al. 1988). Each species of a specific element has different chemical and physical properties sometimes with profound differences in mobility, bioavailability, and/or toxicity in natural systems. Investigating the speciation of metals can provide valuable information on the origin, mode of occurrence, toxicity and mobility of the trace metals to living organisms, and troubleshooting metals' removal from systems such as soil treatment.

Sediments are the principal sink for metals in an aquatic environment, but when the environmental conditions change, sediments can act as a source. The total metal content of the sediments cannot provide a clear picture of the metal loadings and their behavior (such as mobility, toxicity, and bioavailability) with changing environmental conditions. To assess the environmental impact of polluted sediments, information on total concentrations alone is not sufficient because metals are present in different chemical forms in sediments (metal carbonates, oxides, sulfides, organometallic compounds, etc.). Only part of the metals present can be easily remobilized. Thus, the chemical form of the metals in the sediment is of great significance in determining behavior in the environment and their remobilization potential. The environmental behaviour of metals

depends strongly upon the specific chemical form & binding states (Gao and Chen 2012; Gleyzes et al. 2002). One method largely used to estimate the degree of metal contamination of a specific area and the potential risks linked to the increase in metal concentrations is to study the bioavailability of the metals in the sedimentation area (Peña-Icart et al. 2014). Metals are considered bioavailable when they are dissolved in the water column or interstitial water, incorporated to sediments through weak chemical bonds (i.e., the potentially labile parcel) or in metal complexes, and created by a colloidal material such as dissolved organic matter, hydroxyl, carbonates, and sulfides (Bayen 2012). The bioavailability and ecotoxicity of metals in sediment depend on the interactions between many variables such as pH, salinity, redox potential, mineral and organic content, and resident biota (Souza et al. 2015).

The chemical state of elements in the sediments (e.g., easily exchangeable ions, metal carbonates, oxides, sulfides, organometallic compounds, ions in crystal lattices of minerals) depends on prevailing environmental conditions (Usero et al. 1998; Weisz et al. 2000; Yu et al. 2010; Perez-Lopez et al. 2010; Delgado et al. 2011). Recently, Koukina et al. (2016) have shown that both natural (such as turbidities) and human-generated (such as urban and industrial activities) pressures affect the abundance and speciation of potential contaminants (including trace metals) and may change their bioavailability in estuarine system. Anthropogenic influences alter the prevailing environmental conditions (e.g., pH, redox potential, organic matter) which in turn remobilize the sediment-bound metal ions and make them bioavailable to the environment. Trace metals thus released from the sediment into the environment may have adverse impacts on living organisms (e.g., Li et al. 2012; Morillo et al. 2002, 2007; Peng et al. 2009; Delgado et al. 2011). Speciation not only helps in identifying the degree of association of metals in different phases but also distinguishes the origin (lithogenic or anthropogenic) of trace metals in the environment. Several authors (e.g., Izquierdo et al. 1997; Sundaray et al. 2011) have demonstrated that metals associated with the exchangeable and carbonate fraction have an anthropogenic origin, while the residual fraction corresponds to metals with a lithogenic origin.

1.5 Impact of Multiple Stressors on Trace Metal Pollution

1.5.1 Impact of Anthropogenic Activities for Metal Enrichments

Coastal environments are the most dynamic and complex landscapes forming critical habitats for organisms, providing recreational activities and storm protection, and above all enhancing the economic growth through tourism (Johns et al. 2001; Marshall et al. 2014). Rapid urbanization, industrialization, and amplified human population shifting toward the coast have resulted in widespread

modification of coastal ecosystems. The most important threat posed to marine environment is the presence of trace metals, due to their persistence and biogeochemical recycling nature (Liu et al. 2006; Qiao et al. 2013). Humans are also altering marine systems in diverse ways and over unprecedented spatial and temporal scales, resulting in many unexpected outcomes. Coastal areas including estuaries are among the most productive marine ecosystems; it is important that sediment contamination by trace metals be evaluated and that natural versus anthropogenic contribution be distinguished for effective remedial actions against metal pollution (Balls et al. 1997; Chapman and Wang 2001). Various factors such as nature of the sediments, grain size, properties of adsorbed particles, and metal characteristics control the mobility and accumulation of metals in sediments (Bastami et al. 2014). The distinctive sandy, rocky beaches and the various commercial tourist relaxation events, water sports, and other activities are the main tourist attractions. The geochemical studies of trace metals in marine beach environments near to the rapid developing coasts would aid in assessing natural and anthropogenic impacts as well as ecological risks are posed due to the presence of these metals. Sediments serve as a pool of metals that could be released to the overlying water from natural and anthropogenic processes such as fishing and tourist activities, diving, dredging, etc., resulting in potential adverse health effects.

A survey on the metal concentrations (As, Ba, Cd, Co, Cr, Cu, Fe, Mn, Ni, Pb, Sr, V, Zn) in beach water and sediments was reported by Jonathan et al. (2011) from the tourist destination of Acapulco city on the Pacific coast of Mexico. The concentration of dissolved trace metals (DTMs) in beach water and acid leachable trace metals (ALTMs) in sediments indicated that they are anthropogenic in nature due to the increased tourist activities in the crowded beach locations. The statistical analysis indicates both Fe and Mn play a major role as metal scavengers in both the medium (water and sediment) and the higher value of other metals is site specific in the study area, indicating that they are transported from the local area. Comparison results suggest that the beach water quality has deteriorated more than the sediments and necessary measures to be taken to restore the beach quality.

Nagarajan et al. (2013) also investigated the enrichment of partially leached trace metals (PLTMs) (Fe, Mn, Cr, Co, Cu, Ni, Pb, Sr, and Zn) from six different tourist beaches of Miri city, Sarawak, Malaysia. The concentration pattern suggests that the southern side of the study area is enriched with Fe (1821–6097 $\mu\text{g g}^{-1}$), Mn (11.57–90.22 $\mu\text{g g}^{-1}$), Cr (51.50–311 $\mu\text{g g}^{-1}$), Ni (18–51 $\mu\text{g g}^{-1}$), Pb (8.81–84.05 $\mu\text{g g}^{-1}$), Sr (25.95–140.49 $\mu\text{g g}^{-1}$), and Zn (12.46–35.04 $\mu\text{g g}^{-1}$). Compared to the ecotoxicological values, Cr > effects range low (ERL), lowest effect level (LEL), and severe effect level (SEL); Cu > unpolluted sediments, ERL, and LEL; Pb > unpolluted sediments; and Ni > ERL and LEL. Comparative results with other regions indicate that Co, Cr, Cu, Ni, and Zn are higher, indicating an external input rather than natural process. Overall, the results indicated that suitable action needs to be taken on the distribution of construction as well as tourist congestion in the region in order to avoid further

enrichment of toxic metals in the tourist destination (especially in coastal waters) and also the risk of metals entering the biological cycle, which could affect human health in the near future.

Amin et al. (2009) presented a comparative account of distributions, concentrations, and the pollution status of trace metals in Dumai coastal waters in Indonesia. They had considered eastern, central, and western Dumai and southern and northern Rupert Island to establish the effect of anthropogenic activities for accumulation of trace metals in surface sediments. This has been revealed that coastal sediments near Dumai city center (eastern and central Dumai) which have more anthropogenic activities were higher than those at other stations. In contrast, comparatively lower concentrations of trace metals in sediments from Rupert Island which has low human activities were identified. Local hydrodynamic and coastal topography, especially current direction in Rupert Strait, may play an important role in transporting contaminated water from the central Dumai where most of industries and anthropogenic activities were concentrated there and then deposited in the eastern Dumai coastal waters.

The present author and his research group illustrated the large-scale changes in water quality characteristics and plankton community structure due to occurrence of Annual Gangasagar Festival (AGF) at Sagar Island, western part of Indian Sundarban megadelta for 3-year duration (2012–2014; $n = 36$) (Rakshit et al. 2015). About 1 million pilgrims across India converge to take their holy bath at the confluence of Hooghly estuary and Bay of Bengal during January each year. The festival acts as multiple stressors modifying natural functions of the delta. Sound and sustainable management strategies are to be adopted to maintain the protection-usage equilibrium. The AGF is the second largest annual congregation of pilgrims (>1 million) across India taking a holy bath in the farthest southern point of Sagar Island at the mouth of Hooghly estuary (Fig. 2.1). This festival is responsible for multiple stressors that cause beach erosion, shoreline modifications, pollution of beaches with discarded plastic and electronic wastes, as well as destruction of natural habitats (mudflats, coastal dunes, vegetation, etc.), resulting in adverse impact on the coastal diversity. This sensitive ecotone has been subject to tourist, recreational, and festival activities over the years; hence, the authors strongly recommend adopting strategies of integrated river basin management focused on sewage treatment facilities, recycling of waste products, and riparian management. It is worth mentioning that control of coastal water bathing is important.

1.5.2 Interaction Between Climate Change and Dispersion of Pollutants

Human-stressed global climate change has stupendous impacts for marine environments which is changing in a rapid fashion (Hoegh-Guldberg and Bruno 2010; Doney et al. 2012) with unprecedented rates of change in seawater temperature during the last decade (Philippart et al. 2011). This also covers loss of sea ice

cover in the Arctic and Antarctic, sea level rise (SLR), increased occurrence of geohazards, more variable precipitation with more frequent intense rainfall events, and earlier occurrence of springtime algal blooms, especially harmful algal blooms (HABs) (IPCC 2007; Solomon et al. 2007; Hoegh-Guldberg and Bruno 2010).

Climate change pressures are also having profound and diverse consequences on coastal marine ecosystems, not only affecting species distributions and physiology but also ecosystem functioning. In the coastal zone, the environmental variables that may drive ecological responses to climate change include temperature, wave energy, upwelling events, and freshwater inputs, and all act and interact at a variety of spatial and temporal scales. To date, we have a poor understanding of how climate-related environmental changes may affect coastal marine ecosystems or which environmental variables are likely to produce priority effects. Ongoing climate change will affect marine ecosystems in a myriad of ways. Increasing atmospheric CO₂ concentration results in a lowering of ocean pH (ocean acidification) which may, among other effects, impair the viability of calcareous organisms (Doney et al. 2012). This may also result in changes to the concentrations of key chemical species such as hydroxides and carbonate and bicarbonate ions, which will affect the distribution of different forms of trace metals (e.g., biological availability) (Stockdale et al. 2016). Earth's climate has developed to hold adequate warmth from the sun to energize a sound, dynamic biological community, while protecting us from its harsher impacts. The introduction of huge quantity of pollutants thickens this cover of defensive gasses, causing heat to remain trapped within, instead of innocuously getting away upwards. Due to global warming, there are stream on impacts that can exacerbate the situation. Warmer temperatures will tend to increase ocean stratification, restricting the supply of nutrients to photosynthetic organisms in the surface waters (Steinacher et al. 2010). Warmer waters will also reduce the solubility of oxygen and exchange of subsurface low-oxygen waters with the atmosphere, potentially resulting in deoxygenation with subsequent negative effects on marine organisms (Vaquer-Sunyer and Duarte 2008). The synergistic effect of these changes is predicted to be an overall decrease in primary production (PP) over most of the global ocean, with the possible exception of the Arctic region (Bopp et al. 2013).

Metal contamination can be influenced by climate change through a set of potential factors, such as higher temperatures, higher wind speeds, and higher precipitation and freshwater inflow (Maar et al. 2015; Kim et al. 1999; Neumann 2010; Skogen et al. 2011). Temperature can affect metal uptake and depuration and physiological rates of mussels, which influence the body burdens of metals (Mubiana and Blust 2007; Sokolova and Lannig 2008). Wind-induced physical disturbance causes resuspension of particular-bound metals and higher release of dissolved metals from sediment pore water (Eggleton and Thomas 2004; Atkinson et al. 2007), and increased precipitation and freshwater inflow may enhance the exposure to metals in the system (Kim et al. 1999). Hence, the impacts of climate change should be given due emphasis while examining sediment quality assessment in relevance to inorganic and organic microcontaminants.

Thus, it is evident that environmental parameters, temperature, precipitation, and salinity are altered by climate change, which could affect the environmental distribution and biological effect of inorganic (trace metals/metalloids) and persistent organic pollutants (e.g., organochlorine pesticides, polycyclic aromatic hydrocarbons). Perusal of literature reveals that climate change will have wide negative impacts on the distribution and toxicity of environmental contaminants by altering physical, chemical, and biological drivers of partitioning between the atmosphere, water, sediment, and organisms (Bell et al. 2007; Buckman et al. 2007; Confalonieri et al. 2007; Dentener et al. 2006; Fiala et al. 2003; Hogrefe et al. 2004; Knowlton et al. 2004; Macdonald et al. 2005; Patra et al. 2007; Schiedek et al. 2007; Stevenson et al. 2006). Increased contaminants and salinity linked to climate change could enhance the toxicity of some environmental contaminants. Species with narrow ranges of tolerance to changing environmental condition may have difficulty acclimating to climate change. Temperature as well as precipitation, being altered by climate change, are expected to have the largest influence on the partitioning of chemical pollutants. Elevated temperature may alter the biotransformation of contaminants to more bioactive metabolites and impair homeostasis (Noyes et al. 2009).

Sundarban, the tectonically active and geochemically youngest river basin, can be recognized as the most delicate and globally threatened ecosystems residing at the boundary between land and water. This deltaic region is highly vulnerable to climate change producing alterations in temperature, precipitation, erosion, and salinity which can act synergistically to change ecosystem structure and function. IPCC (2007) has projected that with the rise in temperature and subsequent sea level rise in the coastal regions of Asia, including the Indian Sundarban, which would be exposed to increasing risks like coastal erosion. WWF-India (2010) has highlighted rising trend in sea surface temperature (0.019 °C per year) for the Sundarban region and predicted that more than 1.3 million people will be affected by the sea level rise and permanent submergence of land masses, storm surges, and coastal erosions. This will make Sundarban fall under high-risk megadelta by 2020. The climate variability (anomalous precipitations, etc.), extreme weather events (floods, storms), and human activities (tourism, deforestation, coastal construction, and intensive fisheries) expose the wetland to multiple pressures that contribute to further degradation of the estuarine ecosystems in this deltaic region.

Most importantly, increases in the intensity and frequency of storm events as well as floods linked to climate change as frequently observed in these coastal regions could lead to severe chemical contamination to water bodies. These are subjected to driven changes in the structure and functioning of ecosystem most susceptible to the impact of climate change. The possible means by which climate variability affects these wetland ecological processes are many and vary across a broad range of spatiotemporal scales. The Sundarban delta is a vital economic hub in terms of settlement, agriculture, and tourism and of great environmental significance. In recent decades, the prospect of climate change, in particular sea level rise

(SLR), and its effects on low-lying coastal areas have generated worldwide attention of coastal ecosystem. Coastal wetland, as an important part of coastal ecosystem, is particularly sensitive to SLR. To study the responses of coastal wetlands and to formulate feasible and practical mitigation strategies are the important prerequisite for seaming the coastal zone ecosystem.

Trend analysis of long-term weather variables in Sagar Island, the largest delta in the western part of Indian Sundarban, (Fig. 2.1) was elaborately studied by Mandal et al. (Mandal et al. 2013). The Island, a gigantic low-lying archipelago setting on the continental shelf of the Bay of Bengal, is one of the most vulnerable deltas to climate change. Extreme climate-driven multifarious threats, including tidal gushes, deluge with seawater, permanent submergence of land, occurrence of droughts, and water scarcity, have taken a toll on food and environmental security of the island. Significant ($p < 0.5$) anomalies and inter- and intra-annual rainfall distributions (pre-monsoon, monsoon, and postmonsoon months) were observed. The island is experiencing significant ($P < 0.5$) rising trend of interannual mean ($+0.021\text{ }^{\circ}\text{C year}^{-1}$) and maximum temperature ($+0.060\text{ }^{\circ}\text{C year}^{-1}$) with a reverse trend (decline) in minimum temperature ($-0.031\text{ }^{\circ}\text{C year}^{-1}$). Other weather variables like sunshine duration, wind speed, atmospheric evaporative demand, etc. also manifested a complex interaction and significant decreasing trend over long study periods (1982–2000).

The prospect of climate change, in particular sea level rise (SLR), and its impact on low-lying coastal areas have generated worldwide attention on coastal ecosystems (Nicholls et al. 2007; Solomon et al. 2007; Stralberg et al. 2011) and the services they provide particularly in flood management (e.g., Ervin et al. 2012; Fu et al. 2013). The SLR caused by climate change leads to inundation of coastal regions and may be a threat to the low-lying coastal regions (Williams et al. 2009; Chandramohan et al. 2001). Bindoff et al. (2007) reported that the average rate of sea level rise of 1.7 mm/year in the twentieth century was not uniform over decadal periods throughout the century (Church and White 2006; Jeverjeva et al. 2006, 2008). Unnikrishnan et al. (2006) estimated the region-specific sea level rise along the Indian coast, with a regional average of 1.29 mm/year (Unnikrishnan and Shankar 2007). Nandy and Bandopadhyay (2011) showed that the trend of annual sea level rise along the Hooghly River is 1.09 mm/year. This indicates that some areas along the Indian coast might have gone under the sea during the above-referred period and this inundation might be different in the regional scale depending on the topography of the region.

Climate change and catastrophic events will, of course, manifest themselves locally and will alter hydrological, meteorological, and organic carbon cycles. These will change the path of the contaminants through local systems, and there would be an enormous change especially in the rapidly developing industrial countries (including India). Recently, the author and his research group had intensively studied the impact of the tropical severe cyclonic storm “Aila” on the water quality characteristics and mesozooplankton community structure of Sundarban wetland. The Aila incident, which occurred on 25 May 2009, brought sharp changes

in the physicochemical water quality parameters as well as had significant impact on the mesozooplankton (body size 20–200 μm) community structure. An abrupt increase in water turbidity, chemical oxygen demand (COD), phytopigment chlorophyll b (chl b), as well as inorganic nutrients (nitrate, phosphate, and silicate) were noticed during post-Aila period with a corresponding decrease of water transparency and other phytopigments, both chl a and chl c. Reduction of zooplankton numerical density and species diversity index was also distinct during post-Aila period. In general, during storms, water movement in this coastal zone is controlled by forced waves caused by wind, and this movement gets further violent during severe cyclonic storms (SCS) like “Aila” when powerful transport of such water masses takes place landward. These forced waves later transform into free waves or swells and create orbital speeds or currents of high magnitude. The laminar flow of the water masses becomes turbulent with water current of variable speed and directions. During “Aila,” the total surge height of 10–13 m with wind speed of 90–110 kmph lashed the Sundarban wetland and brought about a stupendous change in the ecology of the coastal waters, including imbalance for trophic interactions, altering food web structures and consequent changes in ecosystem functions. This directly facilitates in coastal erosion as well as dispersal of pollutants from potential sources (e.g., adjacent agricultural fields).

The climate variability (seasonality and precipitation), extreme natural events (cyclonic storms, flooding), and intensive anthropogenic activities (boating, dredging, deforestation, tourism, transportation, and intensive fisheries) expose the Sundarban wetland to multiple stressors resulting in degradation of the estuarine ecosystems as a whole. It is worth to mention that these natural dynamics of high-energy meteorological phenomena would determine further the fate of contaminated sediments in the marine environment. Recently, Gopal et al. (2016) documented the enormous changes in trace metal distribution in allogenic polluted sediments caused by severe flood generated by the annual northeast monsoon during November–December 2015. This is the worst natural disaster affecting the Coromandel coastal region of the South Indian states like Tamil Nadu and Andhra Pradesh and the union territory of Puducherry specifically Chennai megacity. The enrichment factor reveals that the sediments are enriched by Pb, Cu, Zn, Cr, Co, and Ni followed by Fe. The observed *Igeo* value shows that the samples are contaminated by Pb, Cu, and Zn. The elemental concentration of the surface sediments is low when compared to other coastal region except Pb. The elevated level of Pb in the surface sediments is probably due to migration of contaminated urban soil from industrial and transportation sectors into marine environment.

1.6 Conclusion

Trace metal(loid) pollution has gained a global attention due to their environmental persistence, non-degradability, biogeochemical recycling, and ecotoxicological problems. Intertidal sediments support a lot of economic activities and thus

vulnerable to human-induced pressures at various scales. This abiotic matrix acts as potential sink and source of both inorganic and organic pollutants, through natural weathering processes and diverse anthropogenic inputs, resulting in health risk associated with impaired food chain. The accumulation and mobility of trace metals in sediments depend on multiple factors, such as nature and concentration of pollutants, chemical species involved, and various physicochemical factors in the environment. The coastal environment of Sundarban wetland and adjacent coastal regions are experiencing profound environmental stress mainly due to the multiple anthropogenic stresses from industrial, domestic, and tourist activities and urgently need to monitor regularly the levels of pollutants in various components of the marine environment. The sediments are known for their ability to accumulate heavy metals introduced into the seas and estuaries through direct industrial and urban effluents, river and atmospheric inputs, and leaching. In addition, river morphology and their interactions with tidal flows play significant role in trace metal distribution. The intensive anthropogenic activities along with the impact of climate changes have profound impact on the dispersal of contaminants including trace metals/metalloids.

References

- Amin B, Ismail A, Arshad A, Yap CK, Kamarudin MS (2009) Anthropogenic impacts on heavy metal concentrations in the coastal sediments of Dumai. *Indonesia Environ Monit Assess* 148:291–305
- Appleby PG (1997) Dating of sediments by ^{210}Pb : problems and solutions. In: Proceedings of a seminar 'dating of sediments and determination of sedimentation rate'. STUK A145, Helsinki, p 7
- Appleby PG, Oldfield F (1992) Application of ^{210}Pb to sedimentation studies. In: Ivanovich M, Harmon RS (eds) Uranium-series disequilibrium: application to Earth, marine, and environmental sciences. Clarendon Press, Oxford, pp 731–778
- Atkinson CA, Jolley DF, Simpson SL (2007) Effect of overlying water pH, dissolved oxygen, salinity and sediment disturbances on metal release and sequestration from metal contaminated marine sediments. *Chemosphere* 69:1428–1437
- Balls PW, Hull S, Miller BS, Pirie JM, Proctor W (1997) Trace metal in Scottish estuarine and coastal sediments. *Mar Pollut Bull* 34:42–50
- Banerjee K, Senthilkumar B, Ramachandran P, Ramesh R (2011) Sedimentation and trace metal distribution in selected locations of Sundarbans mangroves and Hooghly estuary, Northeast coast of India. *Environ Geochem Health* 34(1):27–42
- Basta NT, Ryan JA, Chaney RL (2005) Trace element chemistry in residual treated soil: key concepts and metal bioavailability. *J Environ Qual* 34(1):49–63
- Bastami KD, Bagheri H, Kheirabadi V, Zaferani GG, Teymori MB, Hamzehpoor A, Soltani F, Haghparast S, Harami SR, Ghorghani NF, Ganji S (2014) Distribution and ecological risk assessment of heavy metals in surface sediments along southeast coast of the Caspian Sea. *Mar Pollut Bull* 81(1):262–267
- Bastami KD, Afkhami M, Mohammadzadeh M, Ehsanpour M, Chambari S, Aghaei S, Esmaeilzadeh M, Neyestani MR, Lagzaee F, Baniamam M (2015) Bioaccumulation and ecological risk assessment of heavy metals in the sediments and mullet *Liza klunzingeri* in

- the northern part of the Persian Gulf. *Mar Pollut Bull* 94:329–334. doi:[10.1016/j.marpolbul.2015.01.019](https://doi.org/10.1016/j.marpolbul.2015.01.019)
- Bastami KD, Neyestani MR, Esmaeilzadeh M, Haghparast S, Alavi C, Fathi S, Nourbakhsh S, Shirzadi EA (2016) Geochemical speciation, bioavailability and source identification of selected metals in surface sediments of the Southern Caspian Sea. *Mar Pollut Bull* 114(2):1014–1023
- Bayen S (2012) Occurrence, bioavailability and toxic effects of trace metals and organic contaminants in mangrove ecosystems: a review. *Environ Int* 48:84–101
- Bednarova Z, Kuta J, Kohut L, Machat J, Klanova J, Holoubek I, Jarkovsky J, Dusek L, Hilscherova K (2013) Spatial patterns and temporal changes of metal distributions in river sediments in a region with multiple pollution sources. *J Soils Sediments* 13:1257–1269
- Bell ML, Goldberg R, Hogrefe C, Kinney PL, Knowlton K, Lynn B et al (2007) Climate change, ambient ozone, and health in 50 US cities. *Clim Chang* 82(1–2):61–76
- Beyersmann D, Hartwig A (2008) Carcinogenic metal compounds: recent insight into molecular and cellular mechanisms. *Arch Toxicol* 82:493
- Bindoff NL et al (2007) *Climate change 2007: the physical Science basis, Fourth assessment report of the Intergovernmental panel on climate change*. Cambridge University Press, Cambridge, pp 385–432
- Bodek I, Lyman WJ, Reehl WF, Rosenblatt DH (1988) In: Walton BT, Conway RA (eds) *Environmental inorganic chemistry: properties, processes, and estimation methods*, SETAC Special Publication Series. Pergamon Press, New York
- Bopp L, Resplandy L, Orr JC et al (2013) Multiple stressors of ocean ecosystems in the 21st century: projections with CMIP5 models. *Biogeosciences* 10:6225–6245
- Buckman AH, Brown SB, Small J, Muir DCG, Parrott J, Solomon KR et al (2007) Role of temperature and enzyme induction in the biotransformation of polychlorinated biphenyls and bioformation of hydroxylated polychlorinated biphenyls by rainbow trout (*Oncorhynchus mykiss*). *Environ Sci Technol* 41:3856–3863
- Camargo JBDA, Cruz ACF, Campos BG, Araújo GS, Fonseca TG, Abessa DMS (2015) Use, development and improvements in the protocol of whole sediment toxicity identification evaluation using benthic copepods. *Mar Pollut Bull* 91:511–517
- Castillo MLA, Trujillo IS, Alonso EV, Torres AGD, Pavón JMC (2013) Bioavailability of metals in water and sediments from a typical Mediterranean Bay (Málaga Bay, Region of Andalucía, Southern Spain). *Mar Pollut Bull* 76:427–434
- Çevik F, Göksu MZL, Derici SB, Findik Ö (2009) An assessment of metal pollution in surface sediments of Seyhan dam by using enrichment factor, geoaccumulation index and statistical analyses. *Environ Monit Assess* 152:309–317
- Chandramohan P, Jena BK, Kumar VS (2001) Littoral drift sources and sinks along the Indian coast. *Curr Sci* 81:292–297
- Chapman PM, Wang F (2001) Assessing sediment contamination in estuaries. *Environ Toxicol Chem* 20:3–22. <http://dx.doi.org/10.1002/etc.5620200102>
- Chapman PM, Wang F, Caeiro SS (2013) Assessing and managing sediment contamination in transitional waters. *Environ Int* 55:71–91
- Cheng Z, Man YB, Nie XP, Wong MH (2013) Trophic relationships and health risk assessments of trace metals in the aquaculture pond ecosystem of Pearl River Delta, China. *Chemosphere* 90:2142–2148
- Christophoridis C, Dedepsidis D, Fytianos K (2009) Occurrence and distribution of selected metals in the surface sediments of Thermaikos Gulf N. Greece. Assessment using pollution indicators. *J Hazard Mater* 168:1082–1091
- Church JA, White NJ (2006) A 20th century acceleration in global sea-level rise. *Geophys Res Lett* 33:L01602. doi:[10.1029/2005GL024826](https://doi.org/10.1029/2005GL024826)
- Confalonieri U, Menne B, Akhtar R, Ebi KL, Hauengue M, Kovats RS et al (2007) Human health. In: *Climate change 2007: impacts, adaptation and vulnerability contribution of Working Group*

- II to the Fourth assessment report of the Intergovernmental panel on climate change. Cambridge University Press, Cambridge
- Cukrov N, Frančišković-Bilinski S, Hlača B, Barišić D (2011) A recent history of metal accumulation in the sediments of Rijeka harbor, Adriatic Sea. *Croatia Mar Pollut Bull* 62:154–167
- D'Amore JJ, Al-Abed SR, Scheckel KG, Ryan JA (2005) Methods for speciation of metals in soils: a review. *J Environ Qual* 34(5):1707–1745
- Delgado J, Peláez JA, Tomás R, García-Tortosa FJ, Alfaro P, LópezCasado C (2011) Seismically-induced landslides in the Betic Cordillera (S Spain). *Soil Dyn Earthq Eng* 31:1203–1211
- Dentener F, Stevenson DS, Ellingsen K (2006) The global atmospheric environment for the next generation. *Environ Sci Technol* 40(11):3586–3594
- Ding Z, Liu J, Li L, Lin H, Wu H, Hu Z (2009) Distribution and speciation of mercury in surficial sediments from main mangrove wetlands in China. *Mar Pollut Bull* 58:1319–1325
- Doney SC, Ruckelshaus M, Emmett Duffy J et al (2012) Climate change impacts on marine ecosystems. *Annu Rev Mar Sci* 4:11–37
- Dong A, Zhai S, Zabel M, Yu Z, Zhang H, Liu F (2012) Heavy metals in Changjiang estuarine and offshore sediments: responding to human activities. *Acta Oceanol Sin* 31:88–101
- Eggleton J, Thomas KV (2004) A review of factors affecting the release and bioavailability of contaminants during sediment disturbance events. *Environ Int* 30:973–980
- Ervin D, Brown D, Chang H, Dujon V, Granek E, Shandas V et al (2012) Growing cities depend on ecosystem services. *Solutions* 2(6):74–86
- Fiala J, Cernikovsky L, de Leeuw F, Kurfuerst P (2003) Air pollution by ozone in Europe in summer 2003. Overview of exceedances of EC ozone threshold values during the summer season April–August 2003 and comparisons with previous years. European Environment Agency and the European Topic Centre on Air and Climate Change, Copenhagen
- Fichet D, Radenac G, Miramand P (1998) Experimental studies of impacts of harbor sediments resuspension to marine invertebrates larvae: bioavailability of Cd, Cu, Pb and Zn and toxicity. *Mar Pollut Bull* 36:509–518
- Frignani M, Belluci LG (2004) Heavy metals in marine coastal sediment: assessing sources, fluxes, history and trends. *Anal Chem* 94:479–486
- Fu B, Wang YK, Xu P, Yan K (2013) Mapping the flood mitigation services on ecosystems- a case study in the Upper Yangtze River Basin. *Ecol Eng* 52(0):238–246. <http://dx.doi.org/10.1016/j.ecoleng.2012.11.008>
- Gao XL, Chen CTA (2012) Heavy metal pollution status in surface sediments of the coastal Bohai Bay. *Water Res* 46:1901–1911
- Gleyzes C, Tellier S, Astruc M (2002) Fractionation studies of trace elements in contaminated soils and sediments: a review of sequential extraction procedures. *TrAC Trends Anal Chem* 21:451–467
- Goldberg EG (1963) Geochronology with 210Pb. In: Radioactivity dating. IAEA, Vienna, pp 121–131
- Gopal V, Krishnakumar S, Peter TS, Nethaji S, Kumar S, Jayaprakash KM, Magesh NS (2016) Assessment of trace element accumulation in surface sediments off Chennai coast after a major flood event. *Mar Pollut Bull* 14(2):1063–1071
- Gu YG, Yang YF, Lin Q, Li QS, Wang ZH, Wang XN (2012) Spatial, temporal, and speciation variations of heavy metals in sediments of Nan'ao Island, a representative mariculture base in Guangdong coast. *China J Environ Monit* 14:1943–1950
- Gu YG, Lin Q, Jiang SJ, Wang ZH (2014) Metal pollution status in Zhelin Bay surface sediments inferred from a sequential extraction technique, South China Sea. *Mar Pollut Bull* 81:256–261
- Hakanson L (1992) Sediment variability. In: Burton GA Jr (ed) Sediment toxicity assessment. Lewis Publishers, Boca Raton, pp 19–36
- He Q, Walling DE, Owens PN (1996) Interpreting the ¹³⁷Cs profiles observed in several small lakes and reservoirs in southern England. *Chem Geol* 129:115–131
- Hedge LH, Knott NA, Johnston EL (2009) Dredging related metal bioaccumulation in oysters. *Mar Pollut Bull* 58:832–840

- Hoegh-Guldberg O, Bruno JF (2010) The impact of climate change on the World's marine ecosystems. *Science* 328:1523–1528
- Hogrefe C, Lynn B, Civerolo K, Ku JY, Rosenthal J, Rosenzweig C et al (2004) Simulating changes in regional air pollution over the eastern United States due to changes in global and regional climate and emissions. *J Geophys Res-Atmos* 109(D22301):1–13
- Hu B, Cui R, Li J, Wei H, Zhao J, Bai F, Song W, Ding X (2013) Occurrence and distribution of metals in surface sediments of the Changhua River Estuary and adjacent shelf (Hainan Island). *Mar Pollut Bull* 76:400–405
- Huo S, Xi B, Yu X, Su J, Zan F, Zhao G (2013) Application of equilibrium partitioning approach to derive sediment quality criteria for metals in a shallow eutrophic lake, Lake Chaohu, China. *Environ Earth Sci* 69:2275–2285
- Hwang DW, Yang HS (2003) Distributions of metallic elements in the sediment cores from several shellfish-farming bays in Korea. *J Soc Océan* 38:17–23
- IPCC (2007) IPCC climate change 2007 – Fourth assessment report. Intergovernmental panel on climate change. IPCC, Geneva, p 104
- Izquierdo C, Usero J, Gracia I (1997) Speciation of metals in sediments from salt marshes on the southern Atlantic coast of Spain. *Mar Pollut Bull* 34:123–128. [http://dx.doi.org/10.1016/S0025-326X\(96\)00059-8](http://dx.doi.org/10.1016/S0025-326X(96)00059-8)
- Japan Meteorological Agency (2001) Bulletin of the radioactivity, vol 83. JMA, Tokyo, 21 pp
- Jeverejeva S, Grinsted A, Moore JC, Holgate SJ (2006) Nonlinear trends and multiyear cycles in sea level records. *J Geophys Res* 111:C09012. doi:10.1029/2005JC003229
- Jeverejeva S, Moore JC, Grinsted A, Woodworth PL (2008) Recent global sea level acceleration started over 200 years ago? *Geophys Res Lett* 35:L08715. doi:10.1029/2008GL033611
- Johns GM, Leeworthy VR, Bell,FW, Bonn MA (2001) Socioeconomic study of reefs in Southeast Florida. Final Report for Broward County, Palm Beach County, Miami-Dade County, Florida Fish and Wildlife Conservation Commission, and National Oceanic and Atmospheric Administration. Hazen and Sawyer. Hollywood, p 348
- Jonathan MP, Roy PD, Thangadurai N, Srinivasalu S, Rodríguez-Espinosa PF, Sarkar SK, Lakshumanan C, Navarrete-Lópezf M, Muñoz-Sevilla NP (2011) Metal concentrations in water and sediments from tourist beaches of Acapulco, Mexico. *Mar Pollut Bull* 62:845–850
- Jonge DM, Teuchies J, Meire P, Blust R, Bervoets L (2012) The impact of increased oxygen conditions on metal-contaminated sediments part I: effects on redox status, sediment geochemistry and metal bioavailability. *Water Res* 46:2205–2214
- Kaasalainen M, Yli-Halla M (2003) Use of sequential extraction to assess metal partitioning in soils. *Environ Pollut* 126(2):225–233
- Kabata-Pendias A, Pendias H (2001) Trace metals in soils and plants, 2nd edn. CRC Press, Boca Raton
- Khan S, Cao Q, Zheng YM, Huang YZ, Zhu YG (2008) Health risks of metals in contaminated soils and food crops irrigated with wastewater in Beijing, China. *Environ Pollut* 152(3):686–692
- Kim Y, Powell EN, Wade TL, Presley BJ, Brooks JM (1999) Influence of climate change on interannual variation in contaminant body burden in Gulf of Mexico oysters. *Mar Environ Res* 48:459–488
- Knowlton JER, Hogrefe C, Lynn B, Gaffon S, Goldberg RA, Rosenzweig C et al (2004) Assessing ozone-related health impacts under a changing climate. *Environ Health Perspect* 112(15):1157–1563
- Koide M, Soutar A, Goldberg ED (1972) Marine geochronology with 210Pb. *Earth Planet Sci Lett* 14:442–446
- Koukina SE, Lobus NV, Peresytkin VI, Dara OM, Smurov AV (2016) Abundance, distribution and bioavailability in surface sediments from the Cai River estuary and Nha Trang Bay (South China Sea, Vietnam). *Estuar, Coast Shelf Sci* (in press)
- Krishnaswamy S, Lal D, Martin JM, Meybeck M (1971) Geochronology of lake sediments. *Earth Planet Sci Lett* 11:407–414

- Kuo S, Heilman PE, Baker AS (1983) Distribution and forms of copper, zinc, cadmium, iron, and manganese in soils near a copper smelter. *Soil Sci* 135(2):101–109
- Lai TM, Lee W, Hur J, Kim Y, Huh IA, Shin HS, Kim CK, Lee JH (2013) Influence of sediment grain size and land use on the distributions of metals in sediments of the Han river basin in Korea and the assessment of anthropogenic pollution. *Water Air Soil Pollut* 224:1609–1621
- Le CX (1999) Arsenic speciation in the environment. *Canadian News*:18–20
- Li X, Liu L, Wang Y, Luo G, Chen X, Yang X, Gao B, He X (2012) Integrated assessment of metal contamination in sediments from a coastal industrial basin, NE China. *PLoS One* 7:e39690
- Li C, Song C, Yin Y, Sun M, Tao P, Shao M (2015a) Spatial distribution and risk assessment of heavy metals in sediment of Shuangtaizi estuary, China. *Mar Pollut Bull* 98:358–364
- Lim D, Jung SW, Choi MS, Kang SM, Jung HS, Choi JY (2013) Historical record of metal accumulation and lead source in the southeastern coastal region of Korea. *Mar Pollut Bull* 74:441–445
- Liu J, Cui B, Dong S, Zhu J, Yao W (2006) Study on the effect of highway construction on photosynthetic rate of roadsides plant in longitudinal range-Gorge Region. *Chin Sci Bull* 51(Supp):59–68
- Liu S, Shi X, Yang G, Khokiattiwong S, Kornkanitnan N (2016) Concentration distribution and assessment of heavy metals in the surface sediments of the western Gulf of Thailand. *Environ Earth Sci* 75:346
- Maar M, Larsen MM, Topping D, Petersen JK (2015) Bioaccumulation of metals (Cd, Cu, Ni, Pb and Zn) in suspended cultures of blue mussels exposed to different environmental conditions. *Estuar Coast Shelf Sci*. <http://dx.doi.org/10.1016/j.ecss.2015.10.010>
- Macdonald RW, Mackay D, Li YF, Hickie B (2005) How will global climate change affect risks from long-range transport of persistent organic pollutants? *Hum Ecol Risk Assess* 9(3):643–660
- Malferrari D, Brigatti MF, Laurora A, Pini S (2009) Heavy metals in sediments from canals for water supplying and drainage: mobilization and control strategies. *J Hazard Mater* 161:723–729
- Mandal S, Choudhury BU, Mondal M, Bej S (2013) Trend analysis of weather variables in Sagar Island, West Bengal, India: a long term perspective (1982–2010). *Curr Sci* 105(7):947–953
- Marshall FE, Banks K, Cook GS (2014) Ecosystem indicators for Southeast Florida beaches. *Ecol Indic* 44:81–91
- Matsumoto E (1987) Pb-210 geochronology of sediments. *Studies of the San'in Region. Nat Environ* 3:187–194
- McKee BA, Nittrouer CA, De Master DJ (1983) Concepts of sediment deposition and accumulation applied to the continental shelf near the mouth of the Yangtze River. *Geology* 11(11):631–633
- Michalke B (2003) Element speciation definitions, analytical methodology and some examples. *Ecotoxicol Environ Saf* 56:122–139
- Morillo J, Usero J, Gracia I (2002) Metal fractionation in sediments from the Tinto river (Spain). *Int J Environ An Ch* 82(4):245–257
- Morillo J, Usero J, Gracia I (2007) Potential mobility of metals in polluted coastal sediments in two bays of southern Spain. *J Coast Res* 23:352–361
- Mubiana VK, Blust R (2007) Effects of temperature on scope for growth and accumulation of Cd, Co, Cu and Pb by the marine bivalve *Mytilus edulis*. *Mar Environ Res* 63:219–235
- Musielak S (1985) The Puck Lagoon as an example of basin with sedimentation typical of lagoons Lubiatowo, part II, *Inst. Hydroeng.* In: Giżejowski J, Mielczarski A (eds) *Dynamics of lithodynamic environment of coastal marine areas, materials of I Polish school of sedimentology.* PAS, Gdańsk, pp 412–448. (in Polish)
- Mutia TM, Virani MZ, Moturi WN, Muyela B, Mavura WJ, Lalah JO (2012) Copper, lead and cadmium concentrations in surface water, sediment and fish, *C. Carpio*, samples from Lake Naivasha: effect of recent anthropogenic activities. *Environ. Earth Sci* 67:1121–1130

- Nagarajan R, Jonathan MP, Roy PD, Wai-Hwa L, Prasanna MV, Sarkar SK, Navarrete-López L (2013) Metal concentrate ions in sediments from tourist beaches of Miri City, Sarawak, Malaysia (Borneo Island). *Mar Pollut Bull* 73(2):369–373
- Nandy S, Bandyopadhyay S (2011) Trends of sea level change in the Hugli estuary, India. *Indian J Geo-Mar Sci* 40(6):802–812
- Neumann T (2010) Climate-change effects on the Baltic Sea ecosystem: a model study. *J Mar Syst* 81:213–224
- Nicholas MM (1989) Sediment accumulation rate and relative sea-level rise in lagoons. *Mar Geol* 88(3–4):201–219. [http://dx.doi.org/10.1016/0025-3227\(89\)90098-4](http://dx.doi.org/10.1016/0025-3227(89)90098-4)
- Nicholls RJ, Wong PP, Burkett VR, Codignotto JO, Hay JE, MaLean RF et al (2007) Coastal systems and low-lying areas. In: Parry ML, Canziani OF, Palutikof JP, van der Linden P, Hanson CE (eds) *Climate change 2007: impacts, adaptation and vulnerability. Contribution of working group ii to the Fourth assessment report of the Intergovernmental panel on climate change*. Cambridge University Press, Cambridge
- Nielsen LP, Risgaard-Petersen N, Fossing H, Christensen PB, Sayama M (2010) Electric currents couple spatially separated biogeochemical processes in marine sediment. *Nature* 463:1071–1074
- Niu H, Deng W, Wu Q, Chen X (2009) Potential toxic risk of heavy metals from sediment of the Pearl River in South China. *J Environ Sci* 21(8):1053–1058
- Noronha-D’Mello CA, Nayak GN (2016) Assessment of metal enrichment and their bioavailability in sediment and bioaccumulation by mangrove plant pneumatophores in a tropical (Zuari) estuary, west coast of India. *Mar Pollut Bull* 110:221–230
- Noyes PD, McElwee MK, Miller HD et al (2009) The toxicology of climate change: environmental contaminants in a warming world. *Environ Int* 35:971–986
- Oldfield F, Appleby PG (1984) Empirical testing of ^{210}Pb -dating models for lake sediments. In: Hayworth EY, Lund JWG (eds) *Lake sediments and environmental history*. Leicester University Press, Leicester, pp 93–124
- Owen RB, Lee R (2004) Human impacts on organic matter sedimentation in a proximal shelf setting. *Hong Kong Cont Shelf Res* 24:583–602
- Patra RW, Chapman JC, Lim RP, Gehrke PC (2007) The effects of three organic chemicals on the upper thermal tolerances of four freshwater fishes. *Environ Toxicol Chem* 26(7):1454–1459
- Peña-Icart M, Mendiguchía C, Villanueva-Tagle ME, Pomares-Alfonso MS, Moreno C (2014) Revisiting methods for the determination of bioavailable metals in coastal sediments. *Mar Pollut Bull* 89:67–74
- Peng JF, Song YH, Yuan P, Cui XY, Qiu GL (2009) The remediation of metals contaminated sediment. *J Hazard Mater* 161(2):633–640
- Perez-Lopez R, Nieto JM, Lopez-Coto I, Aguado JL, Bolivar JP, Santisteban M (2010) Dynamics of contaminants in phosphogypsum of the fertilizer industry of Huelva (SW Spain): from phosphate rock ore to the environment. *Appl Geochem* 25:705–715
- Philippart CJM, Anadón R, Danovaro R et al (2011) Impacts of climate change on European marine ecosystems: observations, expectations and indicators. *J Exp Mar Biol Ecol* 400:52–69
- Pierzynski GM, Sims JT, Vance GF (2000) *Soils and environmental quality*, 2nd edn. CRC Press, London
- Plette ACC, Nederlof MM, Temminghoff EJM, van Riemsdijk WH (1999) Bioavailability of heavy metals in terrestrial and aquatic systems: a quantitative approach. *Environ Toxicol Chem* 18:1882–1890
- Protano C, Zinnà L, Giampaoli S, Romano Spica V, Chiavarini S, Vitali M (2014) Heavy metal pollution and potential ecological risks in rivers: a case study from southern Italy. *Bull Environ Contam Toxicol* 92(1):75–80
- Qiao Y, Yang Y, Zhao J, Tao R, Xu R (2013) Influence of urbanization and industrialization on metal enrichment of sediment cores from Shantou Bay, South China. *Environ Pollut* 182:28–36
- Qin Y, Meng W, Zheng B, Su Y (2006) Heavy metal pollution in tidal zones of Bohai Bay using the dated sediment cores. *J Environ Sci* 18(3):610–615

- Ra K, Bang JH, Lee JM et al (2011) The extent and historical trend of metal pollution recorded in core sediments from the artificial Lake Shihwa, Korea. *Mar Pollut Bull* 62(8):1814–1821
- Ra K, Kim E-S, Kim K-Y, Kim J-Y, Lee J-M et al (2013) Assessment of heavy metal contamination and its ecological risk in the surface sediments along the coast of Korea. *J Coast Res* 65:105–110
- Rainbow PS (2007) Tracemetalbioaccumulation: models, metabolic availability and toxicity. *Environ Int* 33:576–582
- Rakshit D, Sarkar SK, Bhattacharya BD, Jonathan MP, Biswas JK, Mondal P, Mitra S (2015) Human-induced ecological changes in western part of Indian Sundarban megadelta: a threat to ecosystem stability. *Mar Pollut Bull* 99:186–194
- Ribeiro AP, Figueiredo AMG, Santos JOD, Dantas E, Cotrim MEB, Cesar LopesFigueira R, Silva Filho EV, Cesar Wasserman J (2013) Combined SEM/AVS and attenuation of concentration models for the assessment of bioavailability and mobility of metals in sediments of Sepetiba Bay (SE Brazil). *Mar Pollut Bull* 68:55–63
- Ritchie JC, McHenry JR (1990) Application of radioactive fallout cesium-137 for measuring soil erosion and sediment accumulation rates and sediment accumulation rates and patterns: a review. *J Environ Qual* 19:215–233
- Robbins JA, Edgington DN (1975) Determination of recent sedimentation rates in Lake Michigan using Pb-210 and Cs-137. *Geochim Cosmochim Acta* 39:285–304
- Rosado D, Usero J, Morillo J (2015) *Mar Pollut Bull* 98:106–114. <http://dx.doi.org/10.1016/j.marpolbul.2015.07.008>
- Sainz A, Ruiz F (2006) Influence of the very polluted inputs of the Tinto–Odiel system on the adjacent littoral sediments of southwestern Spain: a statistical approach. *Chemosphere* 62:1612–1622. <http://dx.doi.org/10.1016/j.chemosphere.2005.06.045>
- Schiedek D, Sundelin B, Readman JW, Macdonald RW (2007) Interactions between climate change and contaminants. *Mar Pollut Bull* 54(12):1845–1856
- Skogen MD, Drinkwater K, Hjøllø SS, Schrum C (2011) North Sea sensitivity to atmospheric forcing. *J Mar Syst* 85:106–114
- Sokolova IM, Lannig G (2008) Interactive effects of metal pollution and temperature on metabolism in aquatic ectotherms: implications of global climate change. *Clim Res* 37:181–201
- Solomon S, Qin D, Manning M, Chen Z, Marquis M, Averyt KB et al (eds) (2007) *Climate change 2007: the physical science basics, contribution of Working Group I to the Fourth assessment report of the Intergovernmental panel on climate change*. Cambridge University Press, Cambridge
- Souza I d C, Rocha LD, Morozesk M, Bonomo MM, Arrivabene HP, Duarte ID, Furlan LM, Monferrán MV, Mazik K, Elliott M, Matsumoto ST, Milanez CRD, Wunderlin DA, Fernandes MN (2015) Changes in bioaccumulation and translocation patterns between root and leaves of *Avicennia schaueriana* as adaptive response to different levels of metals in mangrove system. *Mar Pollut Bull* 94:176–184
- Steinacher M, Joos F, Frölicher TL et al (2010) Projected 21st century decrease in marine productivity: a multi-model analysis. *Biogeosciences* 7:979–1005
- Stevenson DS, Dentener FJ, Schultz MG, Ellingsen K, van Noije TPC, Wild O et al (2006) Multimodel ensemble simulations of present-day and near-future tropospheric ozone. *J Geophys Res-Atmos* 111(D8):D08301
- Stockdale A, Tipping E, Lofts S, Mortimer RJG (2016) Effect of ocean acidification on organic and inorganic speciation of trace metals. *Environ Sci Technol* 50(4):1906–1913
- Stralberg D, Brennan M, Callaway JC, Wood JK, Schile LM, Jongsomjit D et al (2011) Evaluating tidal marsh sustainability in the face of sea-level rise: a hybrid modelling approach applied to San Francisco Bay. *PLoS ONE* 6(11):e27388. <http://dx.doi.org/10.1371/journal.pone.0027388>
- Sundaray SK, Nayak BB, Lin S, Bhatta D (2011) Geochemical speciation and risk assessment of metals in the river estuarine sediments-A case study: Mahanadi basin. *India J Hazard Mater* 186:1837–1846

- Szmytkiewicz A, Zalewska T (2014) Sediment deposition and accumulation rates determined by sediment trap and ^{210}Pb isotope methods in the Outer Puck Bay (Baltic Sea). *Oceanology* 56 (1):85–106
- Tao Y, Yuan Z, Wei M, Xiaona H (2012) Characterization of heavy metals in water and sediments in Taihu Lake, China. *Environ Monit Assess* 184(7):4367–4382
- Templeton DM, Ariese F, Cornelis R, Danielsson L-G, Huntan H, Van Leeuwen HP (2000) Chemical speciation and fractionation of elements: definitions, structural aspects and methodological approach. *Pure Appl Chem* 72:1453–1470
- Teuchies J, De Jonge M, Meire P, Blust R, Bervoets L (2012) Can acid volatile sulfides(AVS) influence metal concentrations in the macrophyte *Myriophyllum aquaticum*. *Environ Sci Technol* 46:9129–9137
- Turner RC, Uy KL, Everhart RC (2015) Fish environmental DNA is more concentrated in aquatic sediments than surface water. *Biol Conserv* 183:93–102
- Unnikrishnan AS, Shankar D (2007) Are sea-level-rise trends along the coasts of the north Indian Ocean consistent with global estimates? *Glob Planet Chang* 57(3):301–307
- Unnikrishnan AS, Rupa Kumar K, Fernandes SE, Michael GS, Patwardhan SK (2006) Sea level changes along the Indian coast: observations and projections. *Curr Sci* 90:362–368
- Ure AM, Quevauviller P, Muntau H, Griepink B (1993a) Speciation of heavy metals in soil and sediments. An account of the environment and harmonization of extraction techniques under the auspices of the BCR of the Commission of the European Communities. *Int J Environ Anal Chem* 51:135–151
- Ure AM, Quevauviller P, Muntau H, Griepink B (1993b) Improvements in the determination of extractable contents of trace metals in soil and sediment prior to certification, EUR Report 14763 EN. Commission of the European Communities, Luxembourg
- Usero J, Gamero M, Morillo J, Gracia I (1998) Comparative study of three sequential extraction procedures for metals in marine sediments. *Environ Int* 24(4):487–496
- Vaquar-Sunyer R, Duarte CM (2008) Thresholds of hypoxia for marine biodiversity. *Proc Natl Acad Sci U S A* 105:15452–15457
- Wang WX, Rainbow PS (2008) Comparative approaches to understand metal bioaccumulation in aquatic animals. *Comp Biochem Physiol C Toxicol Pharmacol* 148:315–323
- Wang H, Wang J, Liu R, Yu W, Shen Z (2015) Spatial variation, environmental risk and biological hazard assessment of metals in surface sediments of the Yangtze River estuary. *Mar Pollut Bull* 93:250–258
- Weisz M, Polyak K, Hlavay J (2000) Fractionation of elements in sediment samples collected in rivers and harbors at lake Balaton and its catchment area. *Microchem J* 67:207–217
- Williams JS et al (2009) Coastal sensitivity to sea-level rise: a focus on the mid-Atlantic region. US Climate Change Science Program (USCCSP), Washington, DC, p 11
- Yang X, Wu P, Yin A, Zhang H, Zhang M, Gao C, Yang X et al (2016) Distribution and source analysis of heavy metals in soils and sediments of Yueqing Bay basin, East China Sea. *Mar Pollut Bull* 115(1–2):489–497. <http://dx.doi.org/10.1016/j.marpolbul.2016.11.046>
- Yu X, Yan Y, Wang W-X (2010) The distribution and speciation of trace metals in surface sediments from the Pearl River estuary and the Daya Bay, southern China. *Mar Pollut Bull* 60:1364–1371. <http://dx.doi.org/10.1016/j.marpolbul.2010.05.012>
- Yu T, Zhang Y, Zhanga Y (2012) Distribution and bioavailability of heavy metals in different particle-size fractions of sediments in Taihu Lake, China. *Chem Speciat Bioavailab* 24 (4):205–215
- Yuan H, Song J, Li S, Li N, Duan L (2012) Distribution and contamination of metals in surface sediments of the south yellow sea. *Mar Pollut Bull* 64:2151–2159
- Zahra A, Hashmi MZ, Malik RN, Ahmed Z (2014) Enrichment and geoaccumulation of metals and risk assessment of sediments of the Kurang Nallah—feeding tributary of the Rawal Lake reservoir. *Pakistan Sci Total Environ* 470–471:925–933
- Zhang MK, Liu ZY, Wang H (2010) Use of single extraction methods to predict bioavailability of metals in polluted soils to rice. *Commun Soil Sci Plant Anal* 41(7):820–831

-
- Zhao L, Xu Y, Hou H, Shanguan Y, Li F (2014) Source identification and health risk assessment of metals in urban soils around the Tanggu chemical industrial district, Tianjin, China. *Sci Total Environ* 468–469:654–662
- Zhuang W, Gao X (2013) Acid-volatile sulfide and simultaneously extracted metals in surface sediments of the southwestern coastal Laizhou Bay, Bohai Sea: concentrations, spatial distributions and the indication of heavy metal pollution status. *Mar Pollut Bull* 76(1):128–138

Abstract

The Indian Sundarban wetland and its adjacent Hooghly (Ganges) River Estuary are situated in the low-lying, meso-macrotidal, humid, and tropical belt, influenced severely by semidiurnal tides of high amplitude. This globally significant estuarine deltaic complex deserves special attention as they support to sustain rich and diverse flora and faunal communities. However, this productive but vulnerable wetland suffers from environmental degradation and becomes susceptible to chemical pollutants including trace metals which have changed the estuarine geochemistry by complex processes. The 24 studied sampling sites are representative of the variable environmental and energy regimes that cover a wide range of substrate behavior, wave–tide climate, geomorphologic–hydrodynamic regimes, and distances from the sea (Bay of Bengal). They have diverse human interference with a variable degree of exposure to heavy metal contamination. The chapter has been dealt with details of selection of the study sites, sampling strategy, instrumental techniques in environmental chemical analyses, and application of statistical methods for interpretation of data. In addition, the diagnostic of sediment contamination and ecological risks using several important indexes along with consensus sediment quality guidelines (SQGs) are also presented along with practical examples and their solutions.

Keywords

Trace metals • Sediment analyses • Sediment quality assessment • Ecological risk • Indian Sundarban • Hooghly estuary

2.1 Study Sites and Selection of Sampling Stations

The Sundarban delta complex, the largest single continuous tract of tidal halophytic mangrove forest in the world, covers ~1 million ha in the deltaic complex of the Ganga, Brahmaputra, and Meghna rivers and is shared between the extreme southern

part of Indian state of West Bengal (~40% in the 24 Parganas district) and southern Bangladesh (~60% Khulna district of Bangladesh). The area experiences a subtropical monsoonal humid climate with an average annual rainfall of 1600–1800 mm. The present investigation covers a wide geographical region of the Bengal Basin and can be broadly divided into Indian Sundarban wetland (mangrove-infested region) and Hooghly River Estuary (the non-mangrove region). The area is interspersed with a cluster of low-lying islands and tidal channel systems through which semidiurnal tides of meso-macrotidal amplitude interplay with moderate to strong wave effects.

Indian Sundarban wetland is a tide-dominated vulnerable and prograding megadelta formed at the estuarine phase of the Hooghly (Ganges) River and Bay of Bengal, presenting the largest continuous tract of mangrove forest beset with typical coastal topographic features. The thick mangrove forests are patterned into islands by deeply meandering and reticulate creek systems with variable width (a few meters to ~500 m) and length (from a few meters to several km). This covers an area of ~10,000 km² and shared by eastern India (38%) and neighboring country Bangladesh (62%). This delta complex is having a geo-genetic link to the tectonic Bengal Basin and presents one of the most dynamic, complex, and vulnerable low-elevation coastal zones (LE CZ), characterized by a complex and intricate network of tidal creeks, which surrounds hundreds of tidal islands exposed to different elevations at high and low semidiurnal tides. This area has been acclaimed as UNESCO World Heritage Site for its capacity of sustaining an excellent biodiversity. This meso-macrotidal coastal environment suffers from environmental degradation due to several anthropogenic activities which potentially influence the system environmental quality, such as solid wastes, agriculture, domestic effluents, rapid human settlements, tourist activities, deforestation, and increasing agricultural and aquaculture practices. A significant ecological pressure in the Hooghly estuarine environment is represented by the huge discharge of domestic and industrial wastes. Multifarious industries, namely, paper, tanneries, textile, chemicals, pharmaceuticals, plastic, and leather, are situated on both the banks in the upper stretch of Hooghly River as shown in Fig. 2.1. In addition, the estuary is also affected by the raw sewage discharged from the highly urbanized megacity Calcutta as well as Howrah city.

These are rapidly developing areas characterized by rapid growth of population, urbanization, and industrialization. Thus, a major concern of these regions is that the rapid economic growth would damage important natural ecosystems and resources and cause severe deterioration of environmental conditions. In addition, climate change may have its most pronounced effect on these wetlands through increasing the average temperature, alterations in hydrological regimes, spatiotemporal variability in precipitation, and the number and severity of extreme events (such as cyclones) as well as cause a rise in sea level. This is worth to refer that the Bay of Bengal has a tropical cyclone frequency of 20% (Barry and Chorley 1987) and when they reach the coast, strong winds coupled with decreased atmospheric pressure (storm surges) cause sea level to rise quickly. The waves of 6–7 m get access to the low-elevation coastal regions and damage the agriculture crops by intrusion of seawater. All these vital changes in extreme climate events can be recognized as a major threat to species survival and the health of natural systems.

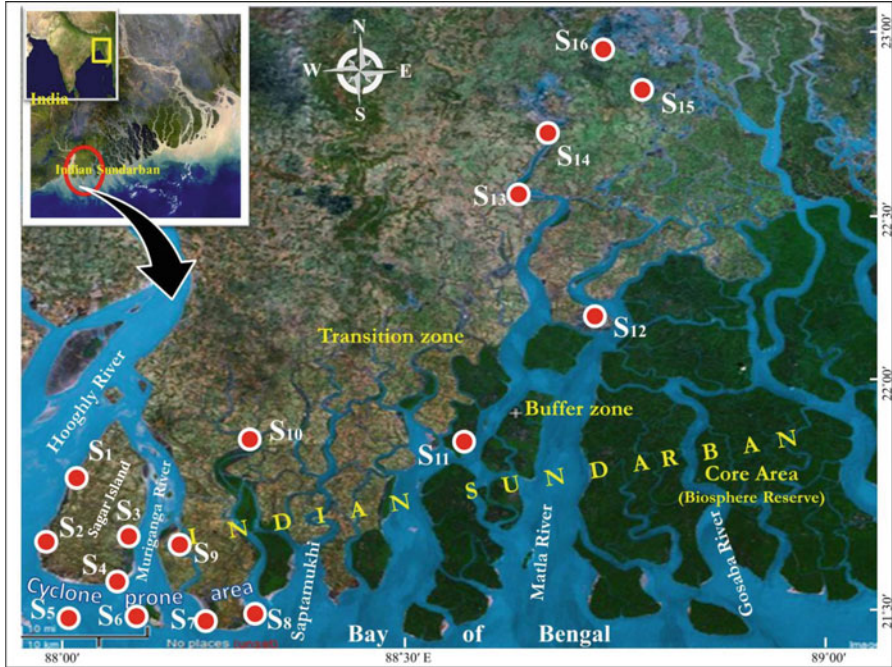

Fig. 2.1 Map of Sundarban wetland showing sampling sites [S₁, Phuldubi; S₂, Mayagoalinir Ghat; S₃, Chemaguri; S₄, Gangasagar; S₅, Lower Long Sand; S₆, Haribhanga; S₇, Frasersgunj; S₈, Bakkhali; S₉, Chandanpiri; S₁₀, Gangadharpur; S₁₁, Jharkhali; S₁₂, Gosaba; S₁₃, Dabu; S₁₄, Canning; S₁₅, Ghushighata; S₁₆, Dhamakhali]

Sampling sites ($n = 16$) were selected covering both the eastern and western flank of Sundarban, namely, Phuldubi, Mayagoalinir Ghat, Chemaguri, Gangasagar, Lower Long Sand, Haribhanga, Frasersgunj, Bakkhali, Chandanpiri, Gangadharpur, Jharkhali, Gosaba, Dabu, Canning, Ghushighata, and Dhamakhali in Sundarban wetland (Fig. 2.1). In addition, seven sampling sites were chosen along the lower stretch of the Hooghly (Ganges) estuary as follows: Barrackpore, Dakshineswar, Uluberia, Babughat, Budge Budge, Diamond Harbour, and Lot 8 (Fig. 6.1).

The Hooghly River Estuary (HRE) ($87^{\circ}55'01''\text{N}$ to $88^{\circ}48'04''\text{N}$ latitude and $21^{\circ}29'02''\text{E}$ to $22^{\circ}09'00''\text{E}$ longitude), the first deltaic offshoot of the Ganges River, is a well-mixed, tide-dominated, positive estuary because of its shallow depth (average ~ 6 m) and drains a catchment of $6 \times 10^4 \text{ km}^2$. This serves as a globally important model region because it provides perpetual water supply to West Bengal for multipurpose activities (such as irrigation, navigation of small ships and fishing boats, human and industry consumption together with fishing) and provides immense ecosystem services, supporting livelihood of millions of people. The estuary gets semidiurnal tides with maximum range of 5.5 m at spring and

minimum 1.8 m at neap. A significant ecological change is pronounced in this area due to huge discharges of untreated or semi-treated domestic and municipal sewage as well as effluents from multifarious industries (namely, paper, tanneries, textile, chemicals, pharmaceuticals, plastic, shellac, leather, jute, coal-based thermal power plants, fertilizer, etc.) carried by rivers as well as contaminated mud disposal from harbor dredging. Recent studies reported that the sedimentation accumulation rate in HRE is $\sim 3.0\text{--}4.8\text{ mm year}^{-1}$ (Banerjee et al. 2012). This high sedimentation rate can cause a change in the geochemical characteristics of the surface sediments on an annual scale as endorsed by other workers (Liu et al. 2011; Zhou et al. 2004). The geographical coordinates of each sampling site were finalized using a handheld global positioning system (GPS).

Situated within the same broad setting of tropical meso-macrotidal amplitude (2.5–6 m) in the lower deltaic plain, the sampling stations considered for the present volume are situated along different salinity gradients, wave and tidal environment, energy regimes, distance from the sea (Bay of Bengal), dispersion of the sediments, and diverse anthropogenic input with a variable degree of exposure from elemental concentrations. These sampling stations belong to distinctive geographic, geomorphic, and sedimentological settings with variations of energy domains characterized by wave–tide climate. Various physicochemical processes such as suspension–resuspension, lateral and vertical transport by biological activities (bioturbation), flocculation and deflocculation of mud clasts, atmospheric deposition, organic carbon (C_{org}) content, and grain size of the sediments are influential in the distribution of metals. Hydrology of these coastal systems presents a cyclic pattern, characterized by large amount of flood and ebb flow and rip and longshore current. The variations of physical processes such as suspension–resuspension, lateral and vertical transport by biological activities (bioturbation), and flocculation and deflocculation of mud clasts result in a spatial variation of the substratum behavior both in local and regional scales. The wave and tide climate of this low-lying tropical coast primarily controls the sediment dispersal patterns. Biogenic subduction and resuspension also play a significant role in the vertical and lateral transportation of sediments.

This coastal environment has been affected by numerous anthropogenic inputs and is becoming a receptor of diverse sources of both inorganic and organic contaminants. This is mainly concerned with rapid human settlement, tourism and port activities, and operation of an excessive number of mechanized boats, deforestation, and increasing agricultural and aquaculture practices. The ongoing degradation is also related to huge siltation, flooding, storm runoff, atmospheric deposition, and other stresses resulting in changes in water quality, depletion of fishery resources, choking of river mouth and inlets, and overall loss of biodiversity as evidenced from previous reports (Sarkar and Bhattacharya 2003, Rakshit et al. 2014). A significant ecological change is pronounced in this area due to huge discharges of untreated or semi-treated domestic and municipal wastes as well as effluents from multifarious industries carried by the rivers as well as contaminated mud disposal from harbor dredging (Sarkar et al. 2007). The sites have diverse

human interferences with a variable degree of exposure to trace metal and trace organic contamination. Moreover, the sites can be differentiated in terms of river discharge, erosion, flocculation, and atmospheric deposition.

A brief description of the studied sampling sites covering Indian Sundarban mangrove wetland as well as the adjacent Hooghly (Ganges) River Estuary is furnished below:

Phuldubi

Phuldubi (latitude 21°46'56"N and longitude 88°04'36"E) is a macrotidal creek situated at the western fringe of the Sagar Island. The creek is directly connected with the main stream of the Hooghly River. Both banks of the creek are covered with dense mangrove swamp. This creek mainly serves as irrigation channel.

Mayagoalinir Ghat

MG Ghat is a tidal creek, situated at latitude 21°47'N and longitude 88°05'E in the western flank of the Sagar Island of Indian Sundarban mangrove wetland and connected with the main stream of the Hooghly River. The main stresses are boating activities and fishing. The discharge from fish docking center is one of the most important point source of pollution in this site.

Chemaguri

Chemaguri (latitude 21°40'N and longitude 88°08'E) is a tidal creek at the eastern flank of the Sagar Island, and it is connected with Muri Ganga River, situated 9 km upstream from the mouth of the estuary and infested by mangrove plants.

Gangasagar

Gangasagar (latitude 21°38'24"N and longitude 88°04'46"E) is situated at the southwestern edge of Sagar Island and faces the eastern margin of the funnel-mouthed Hooghly estuary. The station faces the severity of the wave climate of the coastal Bay of Bengal and a macrotidal amplitude almost throughout the year. This station is thus prone to erosion specially during the episodic phases of tropical cyclones, the severe types of which have a recurrence interval of 3.28 years within 100 km of the island (Bandyopadhyay 1998). The sandy beach of this station often shows a mixture of coarse to fine particles that are derived from breaking down of the pavements. The lower intertidal sediments are subject to constant reworking by waves and tidal currents and thus are composed of more or less clear sand and silt, the clay fraction being absent.

Lower Long Sand

Lower Long Sand (21°33'29"N; 88°03'16"E) is situated at the most seaward part of the estuary and has direct marine influence. This site is situated in an offshore island on the Bay of Bengal.

Haribhanga

Haribhanga ($21^{\circ}37'00.5''\text{N}$; $88^{\circ}04'24.7''\text{E}$) is a small island situated in the Hariabhanga River which is a tidal estuarine river in and around the Sundarbans in North 24 Parganas district in the Indian state of West Bengal, bordering on Satkhira district of Bangladesh. The boating and fishing activities are the main source of pollution.

Frasergunj and Bakkhali

Bakkhali ($21^{\circ}33'04.7''\text{N}$; $88^{\circ}16'27.1''\text{E}$) and Frasergunj ($21^{\circ}34'42.4''\text{N}$; $88^{\circ}13'26.1''\text{E}$) are located on one of the many deltaic islands spread across southern Bengal. Most of the islands are part of the Sunderbans, barring a few at the fringes. Some of these are joined together with bridges over narrow creeks. This small island juts out into the vast expanse of the Bay of Bengal. Tourist activities, ferry services, and fishing were the main source of anthropogenic pollution.

Chandanpiri

This station ($21^{\circ}38'57.4''\text{N}$; $88^{\circ}17'49.6''\text{E}$) is situated on the western bank of Saptamukhi River. This area acts as a fish landing station as well as fish trawler and country boat docking site. A natural mangrove swamp can be seen on the either side of the river, but the natural vegetation is under threat due to the lack of knowledge of the local people who cut down the mangrove trees for creating space for the fishing boats and trawlers.

Gangadharpur

The mudflat of Gangadharpur ($21^{\circ}50.544'\text{N}$; $88^{\circ}18.727'\text{E}$) sampling location is situated on the western bank of the wide Saptamukhi River, a major tidal inlet in the Hooghly–Matla delta complex. A wide variety of mangrove species is present here, but due to lack of information, local people are destroying the forest for human settlement and other purposes.

Jharkhali

Jharkhali ($22^{\circ}02'09.6''\text{N}$; $88^{\circ}41'55.7''\text{E}$) is an eco-hub situated at the western bank of the middle stretch of Matla River experiencing semidiurnal tide. Along with the natural vegetation of mangrove, afforestation program by the Government of India has resulted in a breeding and nursery ground for mangroves here.

Gosaba

Gosaba ($22^{\circ}11'02''\text{N}$; $88^{\circ}49'07''\text{E}$) is situated in the western flank of Gosaba River, tributary of Hooghly River. The region is characterized by Sundarban biosphere reserve. This core region is a unique bioclimatic zone within a typical geographical situation in the coastal region of the Bay of Bengal. The immense tidal mangrove forests of Sundarban are in reality a mosaic of islands of different shapes and sizes, perennially washed by brackish water shrilling.

Dabu

The sampling site (22°15.063' N; 88°38.948' E) is situated by the western side of the upper stretch of Matla River within the tidal channel network of Hooghly–Matla River system. The station experiences intense semidiurnal tides through intricate waterways. The station acts as a tourist and fishing spot, and dominance of *Avicennia* species is noticeable.

Canning and Dhamakhali

These two sampling sites, Canning (22°18'40"N; 88°40'43"E) by the side of Matla River and the other at Dhamakhali (22°21'13"N; 88°52'38"E) by the side of Bidya River, are situated away from the direct influence of Hooghly River but within the tidal channel network of Hooghly–Matla or Hooghly–Bidya river systems.

Ghushighata

Ghushighata (latitude 22°30'N and longitude 88°46'E) is a shallow coastal area, situated at the northern boundary of the Sundarban. The area belongs to the low-lying mesotidal (2–4-m tidal amplitude) flat of the Bidya River, receiving semidiurnal tides with slight diurnal inequality. Situated at a distance of about 110 km from the Bay of Bengal, the area is generally sheltered from direct action.

Barrackpore

Barrackpore is located at 22°45'51"N and 88°20'40"E. It has an average elevation of 15 meters (49 ft). It is located in the Ganges–Brahmaputra delta region in the North 24 Parganas district of West Bengal state. The water was mainly affected due to discharge of sewage from jute industries.

Dakshineswar

Dakshineswar is located at 22°39'20"N and 88°21'28"E. It is situated alongside the Vivekananda Setu, in the North 24 Parganas district, north of Kolkata, on the east bank of Hooghly River and is famous for its temples. These stations belong to a lower deltaic plain experiencing intense semidiurnal tides and wave action with a meso-macrotidal setting (3–6-m amplitude).

Uluberia

Uluberia is located at 22.47°N and 88.11°E. It has an average elevation of 1 m (3.3 ft). It is situated on the bank of Hooghly River. Domestic and industrial effluents were the important source of pollution in this site.

Babughat

Babughat is situated at 22°49'32"N and 88°21'39"E. It is located near the Rabindra Setu, on the east bank of Ganges–Hooghly River. The water was highly turbid due to maritime trade and bathing and submerged of different idols, flowers, and finery particles.

Budge Budge

Budge Budge is located in the southwestern suburbs of Kolkata at $22^{\circ}33'58''\text{N}$ and $88^{\circ}11'16''\text{E}$, on the eastern bank of the Ganges River. Budge Budge owes much of its importance to the oil storage, thermal power plants, and jute mills.

Diamond Harbour

Diamond Harbour is situated at $22^{\circ}11'13''\text{N}$ and $88^{\circ}11'24''\text{E}$ and is the southern suburbs of Kolkata, on the confluence of the Hooghly River quite near where the river meets the Bay of Bengal. Due to ferry service, the water is highly turbid. Moreover, Diamond Harbour is also a fish landing site, and lots of fishing works are done here.

Lot 8

Lot 8 (latitude $21^{\circ}52'29''\text{N}$ and longitude $88^{\circ}10'09''\text{E}$) is situated at the eastern bank of the Muri Ganga River, the bifurcating distributory channel of the Hooghly estuary, about 40 km upstream from its mouth. The flood and ebb tidal currents have distinctive channels with occasional mixing of the two flows at points of major subaqueous shoals. Sedimentation in the station is characterized by dominant clay supposed to be deposited from the “turbidity maxima” (Dyer 1986) of the Hooghly estuary. This station receives waves caused by the south summer wind from the seaward side and, thus, has been given protection at places by constructing brick pavements. The accumulated mud of the upper intertidal zone here is apt to be transported downslope by gravitative movements to be accumulated in the lower intertidal region.

2.2 Sampling Strategy and Preservation of Sediment Samples

Surface (top 0–5 cm) sediment samples were collected from 23 sites (Figs. 2.1 and 6.1) during low tide in the intertidal regions. Plastic material was utilized to avoid metal pollution in the samples. After sampling, the sediment samples were sealed in clean polyethylene bags, transported back to the laboratory within a few hours, and kept frozen until further analysis. The sediment samples were then oven-dried at 60°C , and large calcareous debris and rock and plant fragments were removed.

Core samples were collected with the help of a steel corer (40 cm in length and 5 cm in diameter) which is gently pushed into the sediments and retrieved back in sealed position. They were transported in frozen conditions (-4°C) to the laboratory. The core length varied between stations (maximum depth of 40 cm) due to variations in the nature of substratum. The water on top was decanted, and the samples were subsampled at 4-cm interval with the help of PVC spatula. A thin film of sediment next to the core was left to avoid contamination. A composite sampling process was performed thus creating triplicates for each sampling site.

The samples were oven-dried (40°C) and were disaggregated using an agate mortar and pestle, sieved through 63- μm sieve, which was stored in pre-cleaned inert polypropylene bags for chemical analysis. All glassware used in collection and laboratory were pre-cleaned to minimize external contamination. All visible marine organisms and coarse shell fragments and sea grass leaves and roots were removed manually. The

portion of sieved samples was used for elemental analysis. Another portion of unsieved samples was used for determining sediment quality parameters (organic carbon, pH, and % of silt, clay, and sand). The organic carbon (Corg) content was determined following a rapid titration method (Walkey and Black 1934). pH was measured with a pH meter (model No. 101E) using a combination glass electrode manufactured by MS Electronics (India) Pvt. Ltd. Calcium carbonate was estimated by experimental procedures as presented elsewhere (Chatterjee et al. 2007). Unfortunately sediment dating was not done since the samples were collected from meso-macrotidal environment, which does not suit the dating techniques and the loss of the uppermost cores (Binelli et al. 2007). Mechanical analyses of sediment texture were done by sieving in a Ro-Tap Shaker (Krumbein and Pettijohn 1938) manufactured by W.S. Tyler Company, Cleveland, Ohio, and statistical computation of textural parameters was done by using formulae of Folk and Ward (1957). The grain size analyses were done by separating the sand fraction by wet sieving using a 63- μm mesh sieve. The silt (4–63 μm) and clay (<4 μm) fractions were determined using the pipette method (Gee and Bauder 1986) in which a sample suspension is prepared using sodium hexametaphosphate as the dispersing agent, and aliquots are pipetted at different time intervals and from different depths and dried and weighed for mass determination, and statistical computation of textural parameters was done by using formulae of Folk and Ward (1957). Prior to sampling, all the glassware and plasticware were decontaminated using 10% HNO_3 solution and then rinsed in double-distilled (Milli-Q) water.

The acid-leachable fraction extracts almost the whole degree of elements as it is absorbed by sediments depicting the contamination of an area (Agemian and Chau 1976; Voutsinou-Taliadouri and Varnavas 1995; Janakiraman et al. 2007). The extraction of acid-leachable metals was done by weighing 5 g of dry sediment sample in a 100-ml plastic bottle in which 75 ml of 0.5 N HCl was added, and after mechanically shaking for 16 h, it was filtered with Whatman “A” filter paper. The final filtered solution was analyzed for acid-leachable Fe, Mn, Cr, Cu, Ni, Pb, Cd, Mo, Ag, As, and Ba in ICP-MS. High-Purity Standards (NIST, USA) were used and standard solutions were prepared. The accuracy of the analysis was determined by standard addition method, and the recovery of elements was 75–97%. A standard reference material MAG1 was used to ensure the quality control and accuracy of the analysis. The samples were analyzed in triplicate, and the mean values of the analysis are presented in this study.

2.3 Analytical Protocol

2.3.1 Instrumental Techniques in Environmental Chemical Analysis

2.3.1.1 Atomic Absorption Spectrometry (AAS)

AAS is the most commonest and popular analytical technique in which a sample is vaporized and the non-excited atoms absorb electromagnetic radiation at characteristic wavelengths by the chemical element of interest. In contrast, Atomic Emission

Spectrometry (AES) is the technique in which a sample is vaporized and the atoms present are detected by their emission of electromagnetic radiation at characteristic wavelengths. It has many uses in different areas of chemistry such as clinical analysis of metals in biological fluids and tissues such as whole blood, plasma, urine, saliva, brain tissue, liver, muscle tissue, and semen and in some pharmaceutical manufacturing processes, like minute quantities of a catalyst that remain in the final drug product, and analyzing water for its metal content.

AAS is based on the measurement of the decrease in light intensity from sources (hollow-cathode lamp, HCL) when it passes through a vapor layer of the atoms of the analyte element. A detector measures the wavelengths of light transmitted by the sample and compares them to the wavelengths which originally passed through the sample. A signal processor then integrates the changes in wavelength absorbed, which appear in the readout as peaks of energy absorption at discrete wavelengths. The energy required for an electron to leave an atom is known as ionization energy and is specific to each chemical element. When an electron moves from one energy level to another within the atom, a photon is emitted with energy E . Atoms of an element emit a characteristic spectral line. Every atom has its own distinct pattern of wavelengths at which it will absorb energy, due to the unique configuration of electrons in its outer shell. This enables the qualitative analysis of a sample. The concentration is calculated based on the Beer–Lambert law. Absorbance is directly proportional to the concentration of the analyte absorbed for the existing set of conditions. The concentration is usually determined from a calibration curve, obtained using standards of known concentration. Most common interferences of AAS are (1) chemical interferences, (2) ionization interferences, (3) matrix interferences, (4) emission interferences, (5) spectral interferences, and (6) background absorption.

However, because of interferences, poor reproducibility, and poor detection limits, alternate methods of AAS, as described below, are used for elemental analyses in research samples, either ppm or ppb levels.

2.3.1.2 Flame Atomic Absorption Spectrometry (Flame-AAS)

Atomic absorption spectrometry is an analytical technique for the determination of elements based upon the absorption of electromagnetic radiation by free atoms, in the visible and ultraviolet region ($\lambda = 190\text{--}850\text{ nm}$). The technique has made a radical difference in quantitative multi-elemental analyses of a large number of samples. To obtain a cloud of free atoms, a solution of the analyte is aspirated into a flame when using flame-AAS. Most of the free atoms remain in the electronic ground state. If irradiated with light of their own characteristic resonance wavelength, these atoms will absorb some of the radiation by excitation of the electrons, the absorbance being proportional to the population density of atoms in the flame, thereby permitting a quantitative analysis. AAS is not an absolute technique, which means calibration with standard solutions is required for every new series of measurements (Fig. 2.2).

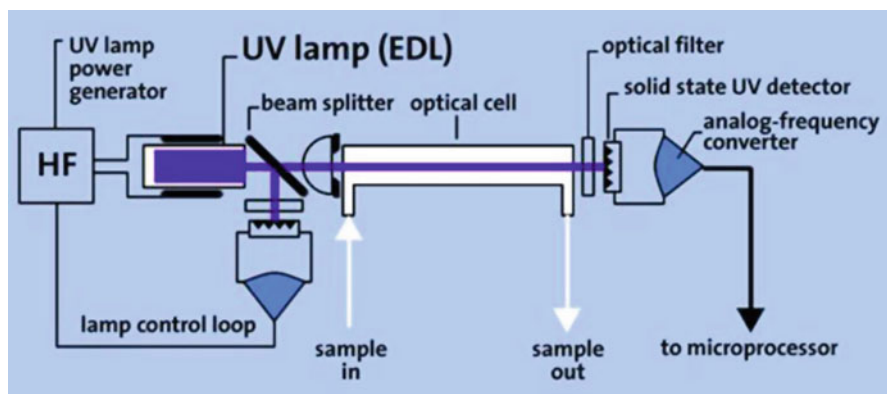

Fig. 2.2 Schematic diagram of the AAS measuring cell unit

2.3.1.3 Graphite Furnace Atomic Absorption Spectrometry (GF-AAS)

A modification of the AAS is the replacement of flame as an atomizer, recognized as electrothermal atomic absorption spectrometry, in which the sensitivity can be improved 1000 times than the conventional flame method. The ultra-trace levels (ng/ml) or ppb level of elements can be detected with the help of a graphite furnace, including the solid sample. The graphite tube which is aligned in the spectrophotometer optical path is an open-ended cylinder of graphite with a small hole in the center through which a small amount of the studied sample is introduced. The temperature is controlled to a maximum of about 3000° by controlling current flow. An inert gas is purged through the graphite tube to prevent tube destruction at high temperature from air oxidation. The internal gas is introduced directly inside the tube from the open ends and escapes out the central hole of the tube. First, the solvent of the solution is evaporated, followed by ashing of the sample, which removes most of the sample matrix. The last stage of the heating program is the atomization phase, which creates a cloud of free atoms in the graphite furnace. The concentration of free atoms in the furnace is measured by absorption of element-specific irradiation through the graphite furnace. This irradiation is produced by a hollow-cathode lamp, which contains the element of interest in its cathode. The amount of absorption is a measure for the concentration of the element in the sample solution.

2.3.1.4 Hydride Generation Atomic Absorption Spectrometry (HG-AAS)

The HG-AAS technique, also known as Mercury-Hydride Systems, is extremely sensitive for the hydride-forming elements such as Hg, As, Bi, Ge, Sb, Se, Sn, and Te as these elements [As III, As V, Se IV, Te IV, Sb III] form volatile hydrides either by zinc hydrochloric acid or sodium borohydride NaBH_4 . Later on, an inert gas stream (argon) separates the analytes from the matrix and leads them toward an electrically heated quartz tube. There are three distinct stages of the technique:

generation of the hydride, transfer to vapor to atomizer, and finally atomization completed at ~ 1000 °C, either electrically or by a flame. In the case of mercury, the solution is treated with SnCl_2 or sodium borohydride (NaBH_4), and the volatile mercury atoms are circulated with argon. As the mercury passed through and out of the cell, a peak-shaped absorption signal is recorded.

The technique is composed of (1) a HCL, (2) air/acetylene flame, and (3) complex hydride generation system. The nebulizer required in AAS is not used in this technique.

Hydride generation is the versatile technique commonly used for As derivatization (Soto et al. 1996; Korte and Fernando 1991), and the basic principle was first devised by Marsh (1836). Speciation of As involves three major steps such as extraction, derivatization and/or separation, and finally detection. It may be used in combination with many different detection systems, including flame and graphite furnace AAS, AES, and colorimetry. It is based on the production of volatile arsines either by zinc/hydrochloric acid or sodium borohydride (NaBH_4)/acid mixtures. The volatile arsines are transported by an inert gas to the detection system. The hydride generation system offers excellent sensitivity because all these elements As III and As V form volatile hydride when reduced by atomic hydrogen (generated by addition of NaBH_4 to acidified solution).

2.3.1.5 Cold-Vapor (Flameless) Atomic Absorption Spectrometry (CV-AAS)

CV-AAS is an extremely sensitive technique to measure total mercury (T_{Hg}) concentration with high precision from 1 ppt (parts per trillion) to 100 ppm (parts per million), and it is highly popular over a long period of time due to its simplicity, robustness, and relative freedom from matrix interferences. This so-called cold-vapor atomic absorption spectroscopy (CV-AAS) typically follows an analogous mechanism involving reduction of both Hg^{2+} and Hg_2^{2+} to metallic Hg in both acid and alkaline media. This is a fast and quantitative reaction, using Sn^{+2} as a reducing agent. The $\text{Hg}(0)$ formed is removed via a stream of argon bubbles and leads toward a quartz cell. Since the vapor contains Hg in atomic form, heating is redundant (hence, the name is cold vapor), except to avoid water vapor in the cell, and the absorbance can be instantly determined. Sensitivity goes well beyond the microgram per liter level, a must for enrichment analysis of this toxic element. For biota, sodium borohydride (NaBH_4) is used often for reduction, while sediment and water samples normally are reduced using SnCl_2 (tin (II) chloride) as a reducing agent at room temperature. To increase sensitivity, gold trap can be used, forming Hg–Ag amalgam, which can be thermally desorbed above 450 °C. Detection limits are typically in the 1–10-ng l^{-1} range with amalgamation, depending on the time/volume of sample preconcentrated onto the gold trap. The mercury concentration is measured in a 230-mm optical cell entirely made of fused silica at a wavelength of 253.7 nm (Fig. 2.3).

Special care is taken for digestion of the measured item as mercury is highly volatile. Microwave technique for digestion is not suitable for mercury. One gram

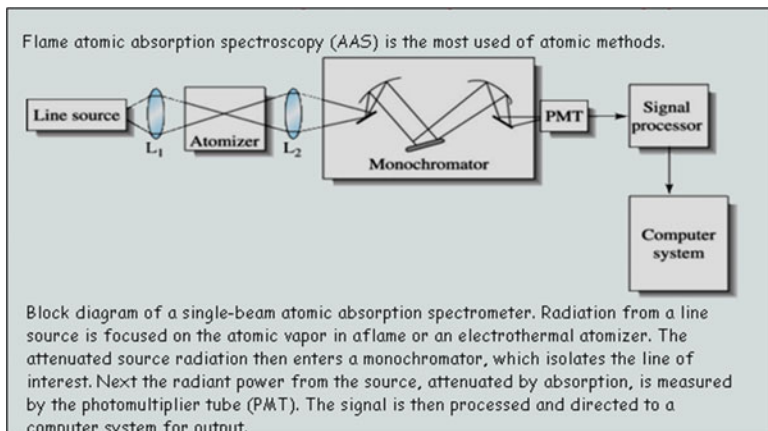

Photograph of AAS with its accessories



Fig. 2.3 Block diagram of the cold-vapor AAS

sample is treated with 4 ml of sulfuric acid Suprapur, Merck, and is kept overnight in a Teflon stopped vessel. The sample is then transferred in the reaction vessel and washed with deionized water. The method is suitable for determination of Hg in both abiotic and biotic matrices.

2.3.1.6 Gas Chromatography

Gas chromatography–tandem mass spectrometry (GC-MS/MS) is a versatile technique for identification and quantification of environmental contaminants in various matrices of environmental, food, and biological interest. It has advantages like high peak resolution, sensitivity, and unique identification abilities (both retention and

mass spectral fragmentation pattern). In order to measure the characteristics of individual molecules, mass spectrometer converts them into ions so that they can be moved about and manipulated by external electric and magnetic fields. The three essential functions of the mass spectrometer and the associated components are as follows: (1) Sample is ionized, usually to cations by loss of an electron. Ion source (2) and the ions are sorted and separated according to their masses and charges. Mass analyzer and (3) the separated ions are then measured and the results displayed on the chart.

Gas chromatography is very useful for forensic investigations, food analysis, drug analysis, and oil analysis. It is very essential for the process of separating and analyzing compounds. This runs on the principle of partition chromatography for separation of components. In terms of stationary and mobile phases, it is categorized under gas-liquid type of chromatography, i.e., stationary phase is a liquid layer supported over a stationary phase, while the mobile phase is an inert and stable gas, hence the perfect name as gas-liquid chromatography (GLC).

The analysis of the components in GC-MS will be performed in the following modes:

- (a) Full-scan mode – A GC-MS system in full-scan mode will monitor a range of mass-to-charge ratio.
- (b) Selected reaction monitoring (SRM): a method used in tandem mass spectrometry in which an ion of a particular mass is selected in the first stage of a tandem mass spectrometer. Products of these ions after fragmentation reaction of the precursor ion are selected in the second mass spectrometer stage for detection.
- (c) Selected ion monitoring (SIM) is limited to selective ion which is transmitted/detected by the instruments, as opposed to the full spectrum range. This mode of operation typically results in significantly increased sensitivity for the ion selected.

The following sources are commonly used in GC-MS/MS:

- (a) Electron ionization (EI) is an ionization method in which energetic electrons interact with gas phase atoms or molecules to produce ions. This technique is widely used in mass spectrometry, particularly for gases and volatile organic molecules.
- (b) Chemical ionization (CI) is an ionization technique used in mass spectrometry. CI is a lower-energy process than electron ionization. The lower energy yields less fragmentation and thus gives usually a simpler spectrum. A typical CI spectrum has an easily identifiable intact molecular species (e.g., a protonated molecule).

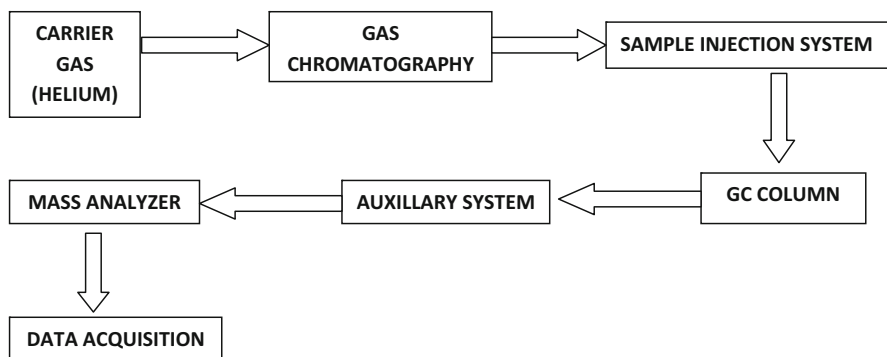
Flow diagram showing the working principle of GC-MS/MS

The gas is set to flow at a constant rate from the cylinder on to the liquid layer impregnated on solid support in a column. The sample is injected into the injection point and is carried by the mobile gas into the column. Inside the column, the components get separated by differential partition in between the mobile phase gas and stationary phase liquid. The component that partitioned into gas comes out of the column first and is detected by detector. The one partitioned into liquid phase comes out later and is also detected. The recordings are displayed onto computer software. From these peaks, one can identify the components and also their concentration (Fig. 2.4). Gas chromatography–mass spectrometry (GC-MS) is an analytical method that combines the features of gas chromatography and mass spectrometry to identify different substances within a test sample (Fig. 2.5).

2.3.1.7 Inductively Coupled Plasma Mass Spectrometry (ICP-MS)

Inductively coupled plasma mass spectrometry (ICP-MS) is a type of mass spectrometry which is being increasingly used as a highly sensitive multi-element analyzer for the trace element analyses (metals, semimetals, and nonmetals) in environmental and biological samples. This implies a unique combination of two techniques: inductively coupled plasma and mass spectrometry. The high temperature of the ICP facilitates almost complete decomposition of the sample into its constituent atoms. The ionization conditions within the ICP result in efficient ionization of majority of the elements in the periodic table.

The instrument has the capacity to measure the low detection limit, as low as one part in 10^{15} (part per quadrillion, ppq). It is capable of analyzing from Li to U and can be applied to solutions, solids, and gasses and widely used due to its versatility and low detection limits. It has its excellent application in identification and quantification of species. Compared to atomic absorption spectroscopy, ICP-MS has greater speed, precision, and sensitivity. The variety of applications exceeds that of inductively coupled plasma atomic emission spectroscopy and includes isotopic speciation. However, due to its very high cost, it is inaccessible to the developing countries (e.g., Bangladesh) that have persistent arsenic contamination.

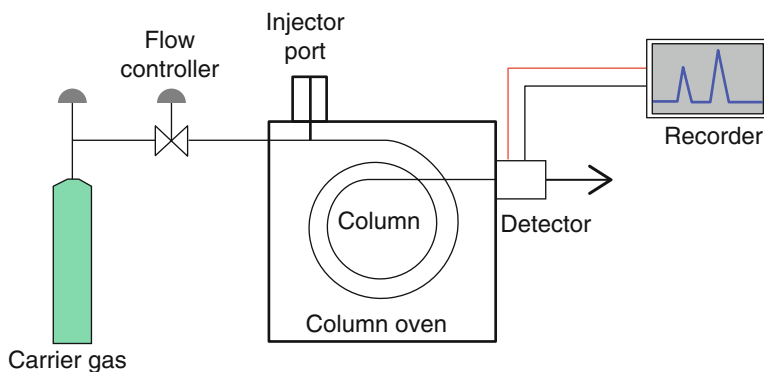

Photograph of Gas Chromatography (GC)



Fig. 2.4 Schematic diagram of the gas chromatography

Using ICP-MS is a sensitive method applied to the analyses of a range of metals. Solutions are vaporized using a nebulizer, while solids can be sampled using laser ablation. Gasses can be sampled directly. The sampled material is introduced into a high-energy argon plasma that consists of electrons and positively charged argon ions. In the plasma, the material is split into individual atoms. These atoms will lose electrons and become (singly) charged positive ions. Most elements ionize very efficiently (>90%) in the hot plasma. The layout of an ICP-MS. To allow their identification, the elemental ions produced in the plasma (ICP) must be transferred from 7000 K to room temperature and from atmospheric pressure to high vacuum. To do so, the ions are extracted through a number of apertures. Besides ions, also



Fig. 2.5 Photograph of Gas chromatography–mass spectrometry (GC-MS)

photons are produced in the plasma. Photons also pass through the apertures. They are not removed by vacuum and produce high background signal when they reach the detector. To minimize this background, a so-called photon-stop is present. This is a small metal plate placed in the center of the ion beam, which reflects the photons away from the detector. The positive ions are not stopped by the photon-stop because a positively charged cylinder lens guides them around it. Subsequently, the ion beam enters the quadrupole mass analyzer. In the quadrupole, the ions are separated on the basis of their mass-to-charge ratio. Each element has its own characteristic isotopes and masses and will therefore produce its own mass spectrum. After passing the quadrupole, the ions hit a special detector. It contains two stages to allow simultaneous measurements of high and low signals. This allows simultaneous detection of main components and ultra-trace elements in a single run, which makes the ICP-MS a perfect tool for survey analysis of totally unknown samples (Fig. 2.6).

2.3.1.8 High-Performance Liquid Chromatography (HPLC)

HPLC has multipurpose uses to separate, identify, and quantify each component in a mixture, e.g., for research purpose (this is most effective for separating the components of a complex biological sample or of similar synthetic chemicals from each other). The instrument has the following components (as shown in Fig. 2.7):

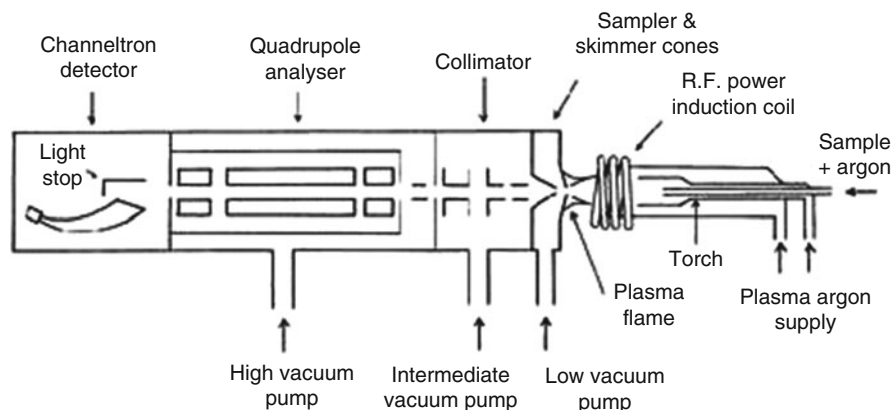

Fig. 2.6 Schematic diagram of ICP-MS

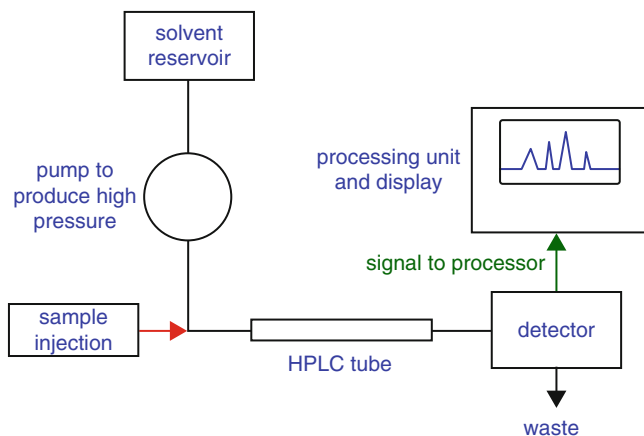

Fig. 2.7 Schematic diagram of HPLC

- (a) **Pumps and controller:** An important component in every HPLC system is its pumps. The pump(s) drives the mobile phase (for washing/equilibration/elution) from the reservoir, as per commands given through the controller, the mixer, and then the injector to the column. Either an isocratic mobile phase (driven by one pump only) or a properly designed gradient elution consisting of two or more solvents or buffers (driven by two or more pumps) is used during HPLC analysis.
- (b) **Injector valve:** samples to be analyzed are injected by a blunt-tipped microsyringe (HPLC syringe) through this part of the instrument.
- (c) **Detector:** After a desired sample is eluted from the column, the next important part is the detection of the right sample present in a mixture by a suitable detector. So, it is very important to know the chemistry of the desired sample.

For example, the nucleotides have absorbance at around 260 nm, while tryptophan and tyrosine have absorbance at 280 nm. Sugars are normally detected using a refractometer, while some of the neurotransmitters are detected by electrochemical detector. Consequently, various detectors are available commercially, viz., multi-wavelength UV/Vis detector, refractive index (RI) detector, fluorescence detector, etc.

- (d) Printer and data analysis: The final part of any HPLC system is a printer where peaks of desired sample are obtained after an expected interval of sample injection (elution time). This is also known as retention time. Retention time should be reproducible, and the system should be pre-calibrated by injecting standard compounds. Retention time is a specific property of every compound. Amount of samples injected should be directly proportional to the peak areas, and a standard curve may be obtained after injecting various amounts of the sample. So, the amount of a component present in an unknown sample may be determined from this standard curve. Nowadays, data analysis is mostly managed efficiently by using a computer.

It is also important to check whether the HPLC is perfectly working at the beginning of any work, and the following checkpoints are to be considered: determination of column efficiency, peak asymmetry factor (A_s), resolution (R), pressure drop ($\pm 30\%$), capacity factor, etc. Development of a right method for the analysis of a particular sample is dependent on some principles stated elsewhere (1–3).

- (e) Column (stationary phase): Like other chromatographic systems, there must be stationary phase and mobile phase. The mixture to be separated is carried through or passed through the stationary phase by the mobile phase, and the separation occurs because the components of the mixture are retarded to different degrees by the stationary phase. This is the most important part of any HPLC instrument, and selection of a right column for the analysis of a particular sample is an extremely important task. HPLC column packings are mostly silica based, and in some instances the packings are polymer based also. The functional mechanism of retention on bare (unmodified) silica gel packings involves interactions of the sample with polar hydroxyl groups on the surface of the silica particle [Si–OH]. Since the silica surface is very polar, retention and therefore the separation are based on the difference in the polar functionalities of different samples. The most polar molecule is more strongly retained (adsorbed) to the silica surface. This is known as normal-phase chromatography in which the packing is more polar than the mobile phase. Since silica is a reactive substrate, functionalities, e.g., C_{18} and C_{18} alkyl, aromatic phenyl, and cyano groups, can be bonded on silica particles. The surface chemistry of silica particle is altered by nonpolar functional groups. Consequently more polar mobile phase can be used when bonded silica is used as a stationary phase, and the process is termed as reversed-phase chromatography. Nowadays this is regularly used for the analysis of complicated samples. There are a number of different kinds of interactions between the

components and the stationary phase (column) which are utilized for the separation of components present in a mixture. Among these, ionic interaction, molecular shape differentiation, hydrophobic interaction, etc. are exploited for designing various kinds of columns.

2.3.1.9 Inductively Coupled Plasma Atomic Emission Spectroscopy (ICP-AES)

Inductively coupled plasma atomic emission spectrometry (ICP-AES) or inductively coupled plasma optical emission spectrometry (ICP-OES) is a well-established and cost-effective emission technique for fast and reliable multi-element analyses, comprising of ICP and optical spectrometer. This is an advanced type of emission spectroscopy using the inductively coupled plasma to produce excited atoms and ions and emitting electromagnetic radiation at specific wavelengths characteristic of an element particular to its atomic character. Due to high-temperature argon plasma, the excited atoms radiate energy at a particular wavelength (Fig. 2.8). The important characteristics of ICP may be furnished as follows:

- High temperatures (~ 8000 K).
- High electron number density ($1-3 \times 10^{15} \text{ cm}^{-3}$).
- The axial channel.
- Long residence time of sample aerosol inside the plasma (2–3 ns).
- Vaporization–atomization in a chemically inert environment.

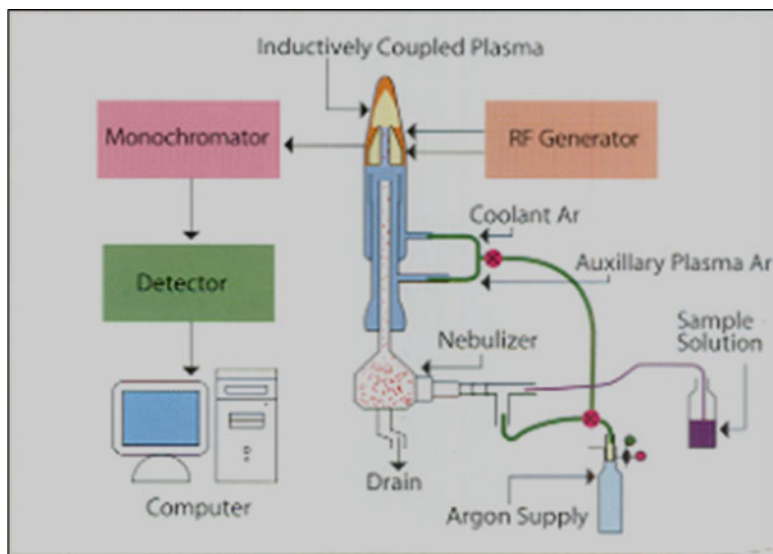

Fig. 2.8 Schematic diagram of ICP-AES

- Molecular species are either absent or present at very low levels.
- High first ionization energy of Ar ~ 15.75 eV.
- Low thermal conductivity of Ar (wrt He) – heat generated within the plasma fireball, sustaining stable operation at moderate power inputs.
- Robustness of the plasma.

2.3.1.10 Energy-Dispersive X-Ray Fluorescence (EDXRF)

XRF is a rapid, nondestructive multi-elemental analysis technique with sensitivity in the range of few ppm to %, and it is ideal for environmental research. This analytical method has been widely and routinely applied to the analysis of various archeological samples, historical relics, and works of art. X-ray fluorescence (XRF) analysis is based on the measurement of characteristic X-rays resulting from de-excitation of inner shell vacancy produced in a sample by means of a suitable source of incident radiation. EDXRF analysis employs detectors that will directly measure the energy of the X-rays in a suitable detecting medium.

X-ray fluorescence (XRF) is the simplest, rapid, accurate, and economic analytical technique used for the elemental analysis or chemical characterization of a wide range of sample, e.g., sodium (11) to uranium (92). XRF is widely used across the world due to its diverse applications as environmental analysis, geology, polymers, and electronics for solids and liquids and with a high sensitivity in detection levels (in the range of few ppm to sub-ppm level) and in most circumstances is nondestructive (Fig. 2.9). It relied on the measurement of characteristic X-rays resulting from de-excitation of inner shell vacancy produced in a sample by means of a suitable source of incident radiation, maintaining the main principle of spectroscopy.

There exists two main XRF methodologies, namely, energy dispersive (EDXRF) and wavelength dispersive (WDXRF), which have its own merits and demerits. In general an EDXRF spectrometer consists of the following components: (1) a source of X-rays, which could be an X-ray generator or radioisotope source; (2) a detector for measuring the X-rays, generally a Si(LI) semiconductor X-ray detector and data acquisition system; and (3) samples for X-ray bombardment.

Analysis by EDXRF involves use of ionizing radiation to excite the sample to be analyzed which ejects electrons from the atomic shells of the elements in the sample. Energy of the emitted fluorescent X-Ray is directly linked to a specific element being analyzed. It employs detectors that will directly measure the energy of the X-rays in a suitable detecting medium. It is this key feature which makes XRF such a fast analytical tool for elemental composition. A number of XRF peaks are possible for a single element, and typically these will all be present in the spectrum, with varying intensities. They form a characteristic fingerprint for a specific element. The energy of the X-ray peaks gives the signature of the element present, whereas the intensity of the peak gives a measure of the concentration.

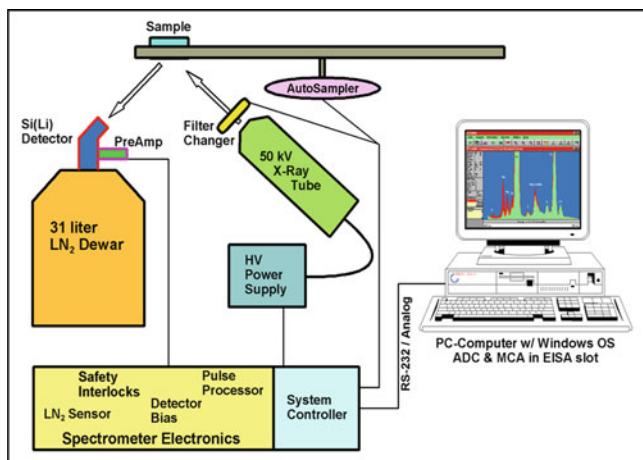

Schematic diagram showing ejecting electron from the atomic shell of an element

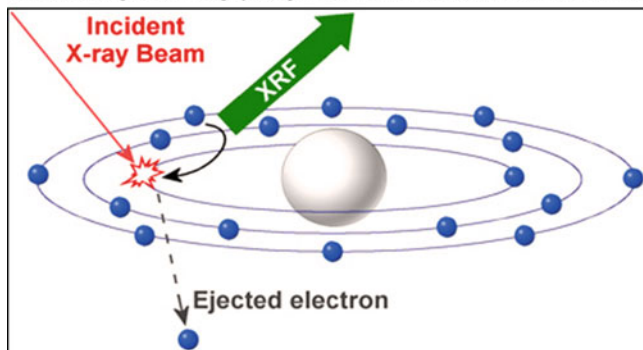

Photograph of ED-XRF



Fig. 2.9 Schematic diagram showing the working principle of EDXRF

2.3.1.11 Diffused Gradients in Thin Film Technique (DGT)

Passive sampling devices such as diffused gradients in thin films (DGTs) are emerging in situ techniques for detecting labile or bioavailable fraction of trace metals or speciation of metal contamination. This is a robust monitoring tool to measure both inorganic and labile organic species by trapping in specialized binding agents (Chelex resin) impregnated on polyacrylamide gel or hydrogel. The gels differentiate between ions based on size and kinetic lability and provide information about the on-site real toxicity. The gels are >90% water, and DGT samples contain gels of diverse pore sizes which can be distinguished between ions based on size and kinetic ability. The metal ions diffuse freely through a well-defined hydrogel layer and are subsequently immobilized in the gel impregnated with an exchange resin. DGT samples are deployed in aquatic systems for hours to days' time period. Later the matter was retrieved, and the gel containing the binding agent is eluted with acid to recover and subsequent analyses of trace elements to be studied. This metal fraction can be treated as representatives of the labile form than the total metal concentration (Campbell 1995).

In turn, semipermeable membrane devices (SPMDs), also a passive sampling device, consist of a membrane filled with the monoacid triglyceride, triolein, especially used to monitor trace levels of nonpolar and hydrophobic compounds which are easily bioavailable for most organisms (Koci et al. 2003). The data are important for examining the amount of chemical in the environment, such as polycyclic aromatic hydrocarbons, polychlorinated biphenyls, polybrominated diphenyl ethers, dioxins, and furans as well as hydrophobic wastewater effluents like fragrances, triclosan, and phthalates.

2.3.2 Quality Assurance/Quality Control

2.3.2.1 Certified Reference Material (CRMs)

CRMs are the "controls" used as a standard protocol to check the accuracy and precision of data generated, to validate analytical techniques, or for the calibration of the used analytical instruments (e.g., AAS). These are also recognized as "standard reference materials" (SRMs) by the National Institute of Standards and Technology (NIST), USA. High-quality CRMs are supplied only from research organizations/institutes with a robust quality system, maintaining a standard analytical protocol, and each certified value is accompanied by an uncertainty at a stated level of confidence. Accuracy and precision of analytical technique interference by matrix components may be estimated through analysis of certified reference materials (CRMs) in which the concentration of the target element is prescribed along with major characteristics of the matrices. The selection of reference material depends primarily on two criteria: (1) it must have a matrix similar to that of the studied sample and (2) similar level of concentration. In case of non-availability of required CRMs, the best option is to validate a method by spiking the sample with standard solutions and then calculating the recovery.

The reference materials provided by NRC Canada (MESS-3, PACS-2, HISS-1) provide wide coverage for a suite of trace elements, including certified values for heavy metals, as well as other transitional, alkali, and alkaline earth metals. CRMs are accompanied by a certificate; one or more of whose property values are certified. CRMs are used for different purposes in measurement quality, estimation of measurement uncertainty, internal quality control, and proficiency testing. Different types of RMs are required for different functions. The certified value is determined by at least two independent analytical methods. The CRM MESS-3 for Marine Sediment Reference Materials for Trace Metals and Other Constituents has been manufactured by the National Research Council of Canada (NRC-CNRC), primarily intended for use in the calibration of procedures and the development of methods for the analysis of marine sediments and materials with similar matrices. A very useful certified reference material for organotin analysis (NIES CRM No. 12 Marine Sediment) was prepared in 1989 by the National Institute for Environmental Studies, Japan, considering surface sediments sampled at the Tokyo Bay. This CRM will be of practical value in maintaining quality assurance for organotin analysis in marine environmental monitoring programs.

2.4 Sediment Quality Assessment and Ecological Risk

Heavy metal contamination has been assessed in diversified way by indexes or indicators, as described below, using the consensus-based sediment quality guideline (SQG). These can provide a perfect assessment of contamination and give a real indication of the ecological state exclusively in sediments in different environmental context. This is mainly based on toxicological probability or indexes based on the background concentration of heavy metals in local sediments. Nevertheless, each assessment method has its own merits and demerits for the assessment of heavy metal contamination, and an approach using background concentrations is the simplest to employ (Song and Choi 2017).

2.4.1 Pollution Load Index (PLI)

For the entire sampling site, PLI has been determined as the n th of the product of the n CF:

$$PLI = \sqrt[n]{(CF_1 \times CF_2 \times CF_3 \times \dots \times CF_n)}$$

where n = number of metals, CF = contamination factor, C_{Sample} = mean metal concentration in polluted sediments, and

$C_{Background\ value}$ = mean natural background value of the studied metal(oids); the world rock average values are chosen for these respective values.

According to Angula (1996), PLI is able to give an estimate the metal contamination status and the necessary action that should be taken. This empirical index provides a simple, comparative means for assessing the level of heavy metal

pollution. When $PLI > 1$, it denotes that metal pollution exists; otherwise, if $PLI < 1$, there is no metal pollution.

2.4.2 Contamination Factor (CF)

Metal concentration of trace metal in a specific study site is controlled by a set of parameters like nature of substrate, physicochemical conditions controlling the dissolution and precipitation of metals, and its distance from the pollution sites. Different metals/metalloids have both synergetic and antagonistic effects on the prevailing environment. CF is considered to be a potential tool in monitoring the pollution over a period of time. It is the ratio obtained by dividing the concentration of each metal in the soil/sediment by baseline or background value (concentration in uncontaminated/unpolluted soil/sediment):

$$CF = \frac{C_{\text{heavy metal}}}{C_{\text{background}}}$$

CF values were interpreted as suggested by Hakanson (1980) where $CF < 1$ indicates low contamination, $1 < CF < 3$ is moderate contamination, $3 < CF < 6$ is considerable contamination, and $CF > 6$ is very high contamination.

Calculate the CF and PLI at the five sampling sites for the following metals.

Given – the background values (proposed by Turekian and Wedepohl 1961) for the metals are as follows:

Cu, 45; Ni, 68; Zn, 95; As, 13; Co, 19; Cd, 0.30

Stations	Cu $\mu\text{g g}^{-1}$	Ni $\mu\text{g g}^{-1}$	Zn $\mu\text{g g}^{-1}$	As $\mu\text{g g}^{-1}$	Co $\mu\text{g g}^{-1}$	Cd $\mu\text{g g}^{-1}$
Sampling site S ₁	21.57	21.07	52.41	18.64	9.49	0.09
Sampling site S ₂	25.26	26.21	61.48	2.05	11.30	0.17
Sampling site S ₃	24.84	26.72	64.45	3.76	10.79	1.04
Sampling site S ₄	23.99	27.73	61.93	7.55	11.16	0.65
Sampling site S ₅	17.89	19.57	37.93	10.00	7.51	0.07

Step 1

To calculate the CF value of Cu for the sampling site S₁

$$\begin{aligned} CF &= \frac{C_{\text{heavy metal}}}{C_{\text{background}}} \\ &= \frac{21.57}{45} \\ &= 0.48 \end{aligned}$$

The CF value Cu was <1 in sediments of sampling site S_1 , which denotes “low contamination” by the metal.

Step 2

Similarly the CF was calculated for all the other metals at all the sampling sites from S_1 to S_5 .

Step 3

The CF values obtained for all the metals at all the sampling sites are as follows:

Stations	Cu	Ni	Zn	As	Co	Cd
Sampling site S_1	0.48	0.31	0.55	1.43	0.50	0.03
Sampling site S_2	0.56	0.39	0.65	0.16	0.59	0.05
Sampling site S_3	0.55	0.39	0.68	0.29	0.57	0.31
Sampling site S_4	0.53	0.41	0.65	0.58	0.59	0.19
Sampling site S_5	0.40	0.29	0.40	0.77	0.40	0.02

Pollution load index (PLI) is calculated for each sampling site taking into account the CF values of all the metals at that particular site. For the entire sampling sites, PLI has been determined as previously described.

Step 1

To calculate the PLI for sampling site S_1

$$\begin{aligned}
 \text{PLI} &= (\text{CF}_{\text{Cu}} \times \text{CF}_{\text{Ni}} \times \text{CF}_{\text{Zn}} \times \text{CF}_{\text{As}} \times \text{CF}_{\text{Co}} \times \text{CF}_{\text{Cd}})^{1/6} \\
 &= (0.48 \times 0.31 \times 0.55 \times 1.43 \times 0.50 \times 0.03)^{1/6} \\
 &= (0.002)^{0.17} \\
 &= 0.34
 \end{aligned}$$

Step 2

Similarly the PLI was determined for all the sampling sites from S_1 to S_5 .

Step 3

The PLI values obtained for all the sampling sites are as follows:

Stations	PLI
Sampling site S_1	0.34
Sampling site S_2	0.30
Sampling site S_3	0.44
Sampling site S_4	0.46
Sampling site S_5	0.26

Result

The PLI of all the sampling sites were <1 , indicating that the studied region was not polluted by the studied metals.

2.4.3 Geoaccumulation Index (I_{geo}) (Müller 1981)

The geoaccumulation index (I_{geo}) could be considered as a contamination index which is applied to evaluate both metal pollution and sediment quality. This is expressed by the following equation:

$$I_{\text{geo}} = \log_2[C_n/1.5B_n]$$

where C_n = measured sediment concentration of the trace element of interest (n) and B_n = geochemical background concentration of the same element. Factor 1.5 denotes background matrix correction factor due to lithospheric effects. I_{geo} is a comparative approach between a present metal concentration and to the preindustrial (uncontaminated) samples.

According to Müller (1981), there are seven classes of metal pollution ranging from 0 ($I_{\text{geo}} < 0$) to 6 ($I_{\text{geo}} > 6$) based on the following classification with gradually increasing I_{geo} values:

I_{geo} value	I_{geo} class	Designation of sediment quality
>5	6	Extremely polluted
4–5	5	Strongly extremely polluted
3–4	4	Strongly polluted
2–3	3	Moderately to strongly polluted
1–2	2	Moderately polluted
0–1	1	Uncontaminated to moderately polluted
0	0	

Find out the I_{geo} values of the following metals at the five sampling sites.

Given – the background values (proposed by Turekian and Wedepohl 1961) are as follows:

Cu, 45; Ni, 68; Zn, 95; As, 13; Co, 19; Cd, 0.30

Stations	Cu	Ni	Zn	As	Co	Cd
	$\mu\text{g g}^{-1}$	$\mu\text{g g}^{-1}$	$\mu\text{g g}^{-1}$	$\mu\text{g g}^{-1}$	$\mu\text{g g}^{-1}$	$\mu\text{g g}^{-1}$
Sampling site S_1	21.57	21.07	52.41	18.64	9.49	0.09
Sampling site S_2	25.26	26.21	61.48	2.05	11.30	0.17
Sampling site S_3	24.84	26.72	64.45	3.76	10.79	1.04
Sampling site S_4	23.99	27.73	61.93	7.55	11.16	0.65
Sampling site S_5	17.89	19.57	37.93	10.00	7.51	0.07

Step 1

To calculate the I_{geo} value of Cu for the sampling site S_1

$$\begin{aligned}
 I_{\text{geo}} &= \log_2(C_n/1.5 * B_n) \\
 &= \log_2(21.57/1.5 * 45) \\
 &= \log_2(21.57/67.5) \\
 &= \log_2(0.32) \\
 &= \frac{\log(0.32)}{\log_2} && [\because \text{Log}_b x = \text{Log}_a x / \text{Log}_a b] \\
 &= \frac{-0.50}{0.30} \\
 &= -1.65
 \end{aligned}$$

The geoaccumulation index value revealed that the sediment from sampling site S_1 can be characterized as practically “uncontaminated” with Cu as the I_{geo} was below zero.

Step 2

Similarly the I_{geo} was calculated for all the other metals at all the sampling sites from S_1 to S_5

Step 3

The I_{geo} values obtained for all the metals at all the sampling sites are as follows:

Stations	Cu	Ni	Zn	As	Co	Cd
Sampling site S_1	-1.65	-2.28	-1.44	-0.06	-1.59	-2.37
Sampling site S_2	-1.42	-1.96	-1.21	-3.25	-1.34	-1.38
Sampling site S_3	-1.44	-1.93	-1.14	-2.37	-1.40	1.21
Sampling site S_4	-1.49	-1.88	-1.20	-1.37	-1.35	0.52
Sampling site S_5	-1.92	-2.38	-1.91	-0.96	-1.92	-2.74

2.4.4 Enrichment Factor (Sakan et al. 2009)

The enrichment factor (EF) is a useful tool as a contamination index in environmental media to assess the extent of sediment contamination with respect to heavy metals by discriminating their naturally occurring and anthropogenic sources. EF of the heavy metal in the studied sample is based on the standardization of measured element against a reference element.

Enrichment factor (EF) is an index used to differentiate the natural metal sources from the anthropogenic ones. It is also used as a tool to reduce the interference of the grain size and mineral composition of the sediments on metal variability. To calculate the EF values for a given metal, the concentration was normalized to the textural characteristics of the Earth’s crust. In this study, iron (Fe) was used as the reference element for geochemical normalization because of the following reasons: (1) Fe is associated with fine solid surfaces, (2) its geochemistry is similar to that of many TEs, and (3) its natural concentration tends to be uniform (Bhuiyan et al. 2010).

The EF values for heavy metals in sediments were calculated using the following formula.

The EF is computed using the relationship below:

$$EF = (C_n/\text{metal})_{\text{sediment}} / (C_n/\text{metal})_{\text{reference}}$$

where C_n = concentration of the examined element “ n ” in the surface sediments.

According to Sakan et al. (2009), seven tiers of contamination levels were categorized based on different EF values: $EF < 1$ indicates no enrichment, < 3 is minor enrichment, 3–5 is moderate enrichment, 5–10 is moderately severe enrichment, 10–25 is severe enrichment, 25–50 is very severe enrichment, and > 50 is extremely severe enrichment. In order to better understand sediment quality and discern the metal contamination, geochemical normalization of enrichment factor is widely employed to identify anomalous metal concentrations for environmental assessment.

Find out the EF values of the following metals at the five sampling sites considering Fe as the reference metal.

Given – the background values are as follows (proposed by Turekian and Wedepohl 1961):

Cu, 45; Ni, 68; Zn, 95; As, 13; Co, 19; Cd, 0.30

Stations	Cu $\mu\text{g g}^{-1}$	Ni $\mu\text{g g}^{-1}$	Zn $\mu\text{g g}^{-1}$	As $\mu\text{g g}^{-1}$	Co $\mu\text{g g}^{-1}$	Cd $\mu\text{g g}^{-1}$	Fe $\mu\text{g g}^{-1}$
Sampling site S_1	226.00	48.00	182.00	7.57	15.80	0.12	40,800
Sampling site S_2	215.00	46.50	185.00	7.13	15.70	0.28	41,100
Sampling site S_3	115.00	22.10	86.00	3.50	7.80	0.29	20,100
Sampling site S_4	148.00	32.70	108.00	5.09	11.30	0.36	28,600
Sampling site S_5	153.00	38.00	113.00	6.03	13.30	0.29	32,600

Step 1

To calculate the EF value of Cu for the sampling site S_1

$$\begin{aligned} EF &= \frac{(\text{Metal/Fe})_{\text{Sample}}}{(\text{Metal/Fe})_{\text{Background}}} \\ &= \frac{(226/40,800)}{(45/47,200)} \\ &= \frac{0.005539}{0.000953} \\ &= 5.81 \end{aligned}$$

The EF value for Cu in the sediments of sampling site S_1 was 5.81, showing “moderately severe enrichment” by this metal.

Step 2

Similarly the EF was calculated for all the other metals at all the sampling sites from S_1 to S_5 .

Step 3

The EF values obtained for all the metals at all the sampling sites are as follows:

Stations	Cu	Ni	Zn	As	Co	Cd
Sampling site S_1	5.81	0.82	2.22	0.67	0.96	0.46
Sampling site S_2	5.49	0.79	2.24	0.63	0.95	1.05
Sampling site S_3	6.00	0.76	2.13	0.63	0.96	2.26
Sampling site S_4	5.43	0.79	1.88	0.65	0.98	2.00
Sampling site S_5	4.92	0.79	1.72	0.67	1.01	1.40

2.4.5 Potential Ecological Risk Index (Hakanson 1980)

Hakanson (1980) developed this unique index of ecological risk assessment dealing with the toxic metals/metalloids in soils/sediments, combining the combined effects of biological toxicology, environmental chemistry, as well as ecology, using the following formula:

$$R_1 = \sum E_r^i$$

where T_i denotes the toxic response factor for a given metal/metalloid i .

The formula for potential ecological risk index for the single heavy metal pollution is as follows:

$$E_r^i = C_f^i \times T_f^i$$

where T_f^i is the response coefficient for the toxicity of the single heavy metal. The formula reveals the hazards of heavy metals on the human and aquatic ecosystem and reflects the level of heavy metal toxicity and ecological sensitivity to the heavy metal pollution. The standardized response coefficient for the toxicity of heavy metals, which was made by Hakanson (1980), was adopted to be an evaluation criterion. Respectively, the corresponding coefficients based on its toxicity were Hg = 40, Cd = 30, As = 10, Cu = Pb = Ni = 5, Cr = 2, and Zn = 1 (Qinna et al. 2005).

The formula for potential toxicity response index for various heavy metals:

$$RI = \sum E_r^i$$

Table showing the relationship among RI, E_r^i , and pollution levels

Scope of potential ecological risk index (E_r^i)	Ecological risk level of single-factor pollution	Scope of potential toxicity index (RI)	General level of potential ecological risk
$E_r^i < 40$	Low	$RI < 150$	Low grade
$40 \leq E_r^i < 80$	Moderate	$150 \leq RI < 300$	Moderate
$80 \leq E_r^i < 160$	Higher	$300 \leq RI < 600$	Severe
$160 \leq E_r^i < 320$	High	$600 \leq RI$	Serious
$320 \leq E_r^i$	Serious		

Calculate the RI of the following metals.

Given – the background values (proposed by Turekian and Wedepohl 1961) for the metals are as follows:

Cu, 45; Ni, 68; Zn, 95; As, 13; Co, 19; Cd, 0.30; Fe, 47,200

Given: T_r^i of Cu = 5, Ni = 5, Zn = 1, and As = 10.

Stations	Cu	Ni	Zn	As	Co
	$\mu\text{g g}^{-1}$	$\mu\text{g g}^{-1}$	$\mu\text{g g}^{-1}$	$\mu\text{g g}^{-1}$	$\mu\text{g g}^{-1}$
Sampling site S ₁	21.57	21.07	52.41	18.64	9.49
Sampling site S ₂	25.26	26.21	61.48	2.05	11.30
Sampling site S ₃	24.84	26.72	64.45	3.76	10.79
Sampling site S ₄	23.99	27.73	61.93	7.55	11.16
Sampling site S ₅	17.89	19.57	37.93	10.00	7.51

Step 1

The contamination factors of all the metals were calculated as described in Sect. 2.4.2. The contamination factor (C_f) of Ni at sampling site S₁ was calculated as follows:

$$\begin{aligned}
 C_f^i &= C_n^i / C_r^i \\
 &= \frac{21.57}{68} \\
 &= 0.31
 \end{aligned}$$

Step 2

To calculate E_r^i for Ni at sampling site S₁ [$T_{Ni}^i = 5$]

$$\begin{aligned}
 E_r^i &= T_r^i \times C_f^i \\
 &= 5 \times 0.31 \\
 &= 1.55
 \end{aligned}$$

Step 3

E_r^i was calculated considering Cu, Ni, Zn, and As since the toxic factor (T_r^i) for Co was unavailable.

Similarly the E_r^i was calculated for all the other metals at all the sampling sites from S_1 to S_5 .

Stations	Cu	Ni	Zn	As
Sampling site S_1	2.40	1.55	0.55	14.34
Sampling site S_2	2.81	1.93	0.65	1.58
Sampling site S_3	2.76	1.96	0.68	2.89
Sampling site S_4	2.67	2.04	0.65	5.81
Sampling site S_5	1.99	1.44	0.40	7.69

The potential ecological risk index for single metal (E_r^i) of Cu, Ni, Zn, and As in all the sampling sites was lower than 40, indicating slight potential ecological risk of five metals in these sampling sites.

Step 4

To calculate the RI of these metals at sampling site S_1

$$\begin{aligned}
 RI &= \sum E_r^i \\
 &= E_{Cu}^i + E_{Ni}^i + E_{Zn}^i + E_{As}^i \\
 &= 2.40 + 1.55 + 0.55 + 14.34 \\
 &= 18.84
 \end{aligned}$$

Step 5

Similarly the RI value was calculated for all the sampling sites from S_1 to S_5 .

Stations	RI
Sampling site S_1	18.84
Sampling site S_2	6.96
Sampling site S_3	8.30
Sampling site S_4	11.16
Sampling site S_5	11.52

Results

The RI values of metals in sediment samples of all the sampling sites were lower than 150 indicating low potential ecological risk.

2.4.6 Modified Degree of Contamination (mC_d) (Abraham 2005)

The modified degree of contamination (mC_d) is defined as the sum of all the contamination factors (CFs) for a given set of estuarine pollutants divided by the

number of analyzed pollutants. The mean concentration of a pollutant element is based on the analysis of at least three samples of the impacted sediments (taken from either the uppermost layers of a core or from the associated surficial sediments). The baseline concentrations are determined from lower core concentrations or from similar nearby uncontaminated sediments.

$$\text{Modified degree of contamination (mC}_d) = \frac{\sum_{i=1}^n \text{CF}^i}{n}$$

where n = no. of analyzed metals, i = i th element (or pollutant), CF = contamination factor = $C_{\text{sample}}/C_{\text{background}}$

For the classification and description of the modified degree of contamination (mC_d) in estuarine sediments, the following gradations are proposed:

$\text{mC}_d < 1.5$	Nil to very low degree of contamination
$1.5 \leq \text{mC}_d < 2$	Low degree of contamination
$2 \leq \text{mC}_d < 4$	Moderate degree of contamination
$4 \leq \text{mC}_d < 8$	High degree of contamination
$8 \leq \text{mC}_d < 16$	Very high degree of contamination
$16 \leq \text{mC}_d < 32$	Extremely high degree of contamination
$\text{mC}_d \geq 32$	Ultrahigh degree of contamination

Calculate the mC_d at the five sampling sites for the following metals.

Stations	Cu $\mu\text{g g}^{-1}$	Ni $\mu\text{g g}^{-1}$	Zn $\mu\text{g g}^{-1}$	As $\mu\text{g g}^{-1}$	Co $\mu\text{g g}^{-1}$	Cd $\mu\text{g g}^{-1}$
Sampling site S_1	21.57	21.07	52.41	18.64	9.49	0.09
Sampling site S_2	25.26	26.21	61.48	2.05	11.30	0.17
Sampling site S_3	24.84	26.72	64.45	3.76	10.79	1.04
Sampling site S_4	23.99	27.73	61.93	7.55	11.16	0.65
Sampling site S_5	17.89	19.57	37.93	10.00	7.51	0.07

Step 1

The CF for the above metals was calculated as described in Sect. 2.4.2.

Stations	Cu	Ni	Zn	As	Co	Cd
Sampling site S_1	0.48	0.31	0.55	1.43	0.50	0.03
Sampling site S_2	0.56	0.39	0.65	0.16	0.59	0.05
Sampling site S_3	0.55	0.39	0.68	0.29	0.57	0.31
Sampling site S_4	0.53	0.41	0.65	0.58	0.59	0.19
Sampling site S_5	0.40	0.29	0.40	0.77	0.40	0.02

Step 2

To calculate the mC_d for the metals at sampling site S_1

$$\begin{aligned}
 \text{Modified Degree of Contamination (} mC_d \text{)} &= \frac{\sum_{i=1}^n Cf^i}{n} \\
 &= \frac{[CF_{Cu} + CF_{Ni} + CF_{Zn} + CF_{AS} + CF_{Co} + CF_{Cd}]}{6} \\
 &= \frac{0.48 + 0.31 + 0.55 + 1.43 + 0.50 + 0.03}{6} \\
 &= \frac{3.3}{6} \\
 &= 0.55
 \end{aligned}$$

Step 3

Similarly, the mC_d for all the sampling sites were calculated.

Stations	mC_d
Sampling site S_1	0.55
Sampling site S_2	0.40
Sampling site S_3	0.47
Sampling site S_4	0.49
Sampling site S_5	0.38

Results

The range of mC_d values indicates nil to very low degree of sediment contamination in the studied region.

2.4.7 Nemerow Pollution Load Index (Guang et al. 2010; Qingjie et al. 2008)

The Nemerow pollution index was used to determine whether or not sampling sites were polluted:

$$PI = \sqrt{\left[(Cf_{\text{mean}})^2 + (Cf_{\text{max}})^2 / 2 \right]}$$

where

Cf = contamination factor

Nemerow pollution index sediment quality indicators:

PI value	Qualification of sediment
PI < 0.7	Non-polluted sediment
0.7 < PI < 1	Nearly polluted sediment
1 < PI < 2	Lightly polluted sediment
2 < PI < 3	Moderately polluted sediment
3 < PI	Seriously polluted sediment

2.4.8 Mean ERM Quotient (m-ERM-Q) (Long et al. 1998)

In order to determine the possible biological effect of combined toxicant groups, one can calculate the mean quotient for a large range of contaminants. Mean ERM quotients have been related to probability of toxicity.

$$\text{Mean ERM quotient (m-ERM-Q)} = \frac{1}{n} \sum_{i=1}^n [(C_i / \text{ERM}_i) / n]$$

where

C_i = sediment concentration of the compound i

ERM_i = effects range median for compound i

N = number of compound i .

Mean ERM quotient (m-ERM-Q)	Probability of toxicity (%)
m-ERM-Q < 0.1	12
0.11 < m-ERM-Q < 0.5	30
0.51 < m-ERM-Q < 1.5	40
m-ERM-Q > 1.5	74

Calculate the m-ERM-Q of the following metals at different sampling sites.

The ERM of the metals is as follows: 51.6 $\mu\text{g g}^{-1}$ for Ni, 270 $\mu\text{g g}^{-1}$ for Cu, 410 $\mu\text{g g}^{-1}$ for Zn, 70 $\mu\text{g g}^{-1}$ for As, and 218 $\mu\text{g g}^{-1}$ for Pb.

Stations	Ni $\mu\text{g g}^{-1}$	Cu $\mu\text{g g}^{-1}$	Zn $\mu\text{g g}^{-1}$	As $\mu\text{g g}^{-1}$	Pb $\mu\text{g g}^{-1}$
Sampling site S_1	21.07	21.57	52.41	18.64	20.60
Sampling site S_2	26.21	25.26	61.48	2.05	19.10
Sampling site S_3	26.72	24.84	64.45	3.76	23.38
Sampling site S_4	27.73	23.99	61.93	7.55	22.91
Sampling site S_5	19.57	17.89	37.93	10.00	14.40

Step 1

To calculate the m-ERM-Q for the metals at sampling site S₁

$$\begin{aligned} \text{m-ERM-Q} &= \frac{\sum_{i=1}^n (C_i/\text{ERM}_i)}{n} \\ &= \frac{[(\text{Ni}/\text{ERM}_{\text{Ni}}) + (\text{Cu}/\text{ERM}_{\text{Cu}}) + (\text{Zn}/\text{ERM}_{\text{Zn}}) + (\text{As}/\text{ERM}_{\text{As}}) + (\text{Pb}/\text{ERM}_{\text{Pb}})]}{5} \\ &= \frac{[(21.07/51.6) + (21.57/270) + (52.41/410) + (18.64/70) + (20.60/218)]}{5} \\ &= 0.20 \end{aligned}$$

Step 2

Similarly the m-ERM-Q was calculated at all the sampling sites S₁ – S₅ to assess the toxicity of the metals.

Stations	m-ERM-Q
Sampling site S ₁	0.20
Sampling site S ₂	0.17
Sampling site S ₃	0.19
Sampling site S ₄	0.20
Sampling site S ₅	0.15

Results

The m-ERM-Q of the present study varied from 0.150 to 0.20 for all the sampling sites indicating that the combined effects of the selected metals in the sediments might cause 30% probability of being toxic to the biota.

2.4.9 Mean PEL Quotient (m-PEL-Q)

In order to evaluate the possible biological effects of the coupled toxicity of metals in the sediments, the mean PEL quotient (m-PEL-Q) by Long et al. 1998 was used, and values were calculated using the following formula:

$$\text{mean PEL quotient} = \frac{\sum_{i=1}^n (C_i/\text{PEL}_i)}{n}$$

where C_i is the sediment concentration of metal “ i ,” PEL_i is the probable effects level (PEL) for metal “ i ,” and “ n ” is the number of the studied metals. It was reported that the mean PEL quotients of <0.1 have a 9% probability of being toxic, the mean PEL quotients of 0.11–0.5 have a 21% probability of being toxic, the mean PEL quotients of 0.51–1.5 have a 49% probability of being toxic, and the

mean PEL quotients of >1.50 have a 76% probability of being toxic (Long et al. 2000).

Calculate the m-PEL-Q for the given metals at the following sites:

Given: PEL values ($\mu\text{g g}^{-1}$) for Cu, Ni, Zn, As, Co, and Cd are 108.20, 42.80, 271.0, 41.60, 0.70, and 4.20 respectively.

Stations	Cu $\mu\text{g g}^{-1}$	Ni $\mu\text{g g}^{-1}$	Zn $\mu\text{g g}^{-1}$	As $\mu\text{g g}^{-1}$	Hg $\mu\text{g g}^{-1}$	Cd $\mu\text{g g}^{-1}$
Sampling site S ₁	226.00	48.00	182.00	7.57	0.04	0.12
Sampling site S ₂	215.00	46.50	185.00	7.13	0.04	0.28
Sampling site S ₃	115.00	22.10	86.00	3.50	0.02	0.29
Sampling site S ₄	148.00	32.70	108.00	5.09	0.47	0.36
Sampling site S ₅	153.00	38.00	113.00	6.03	0.03	0.29

Step 1

To calculate the m-PEL-Q for the metals at sampling site S₁

$$\begin{aligned} \text{mean PEL quotient} &= \frac{\sum_{i=1}^n (C_i/\text{PEL}_i)}{n} \\ &= \frac{[(\text{Cu}/\text{PEL}_{\text{Cu}}) + (\text{Ni}/\text{PEL}_{\text{Ni}}) + (\text{Zn}/\text{PEL}_{\text{Zn}}) + (\text{As}/\text{PEL}_{\text{As}}) + (\text{Hg}/\text{PEL}_{\text{Hg}}) + (\text{Cd}/\text{PEL}_{\text{Cd}})]}{6} \\ &= \frac{[(226/108.20) + (48/42.80) + (182/271) + (7.57/41.60) + (0.04/0.70) + (0.12/4.20)]}{6} \\ &= \frac{2.09 + 1.12 + 0.67 + 0.18 + 0.06 + 0.03}{6} \\ &= 0.69 \end{aligned}$$

Step 2

Similarly the m-PEL-Q was calculated at all the sampling sites S₁ – S₅ to assess the toxicity of the metals.

Stations	m-PEL-Q
Sampling site S ₁	0.69
Sampling site S ₂	0.67
Sampling site S ₃	0.35
Sampling site S ₄	0.57
Sampling site S ₅	0.50

Results

The m-PEL-Q of the present study varied from 0.50 to 0.69 for sampling sites S₁, S₂, S₄, and S₅ indicating 49% probability of being toxic, while for the sampling site S₃, the m-PEL-Q value falls in the range of 0.11–0.50, indicating that the combined effects of the selected metals in the sediments might cause 21% probability of being toxic to the biota (Table 2.1).

Table 2.1 Synoptic features of the CRMs generally used for marine sample analyses

CRM	Characteristics	Certified arsenic value (expressed in $\mu\text{g g}^{-1}$ dry wt)	Producer
	<i>Marine organisms</i>		
CRM 279	Sea lettuce	3.09	BCR
DOLT-1	Dogfish liver	10.1 ± 1.4	NRCC
DORM-1	Dogfish muscle	17.7 ± 2.1	NRCC
TORT-1	Lobster hepatopancreas	24.6 ± 2.2	NRCC
NIES-6	Mussel (mousse)	9.2 ± 0.05	NIES
NIES-9	Sargasso seaweed	115 ± 9	NIES
	<i>Sediment</i>		
BCSS-1	Marine sediment	11.1 ± 1.4	NRCC
MESS-1	Marine sediment	10.6 ± 1.2	NRCC
SRM 1646	Estuarine sediment	11.6 ± 1.3	NIST

BCR Community Bureau of Reference, Belgium; NRCC National Research Council of Canada; NIES National Institute for Environmental Studies, Japan; NIST National Institute of Standards and Technology, Maryland, USA

2.4.10 Sediment Quality Guidelines (SQGs)

2.4.10.1 Effects Range-Low and Effects Range-Medium Values

This is very important to determine whether the concentrations of trace metals/metalloids in sediments pose a threat to the adjacent biota. Numerous sediment quality guidelines are used to protect aquatic biota from the harmful and toxic effects related with sediment-bound contaminants; they are a useful assessment tool of the potential pollution. These guidelines evaluate the degree to which the sediment-associated chemical status might adversely affect aquatic organisms and are designed for the interpretation of sediment quality. The most frequently used ERL–ERM guidelines were developed by the US National Oceanic and Atmospheric Administration (NOAA) to provide the effects range low (ERL) and effects range median (ERM) prescribed as sediment quality guidelines (SQGs). This delineated three concentration ranges for each xenobiotic and the corresponding estimation of the potential biological effect (Long et al. 1995). Concentrations below ERL represent a minimal effect observed. In contrast, concentrations at or above ERM values represent a probable effects range within which adverse biological effects frequently occur. Chemical levels in sediments between ERL and ERM represent a range within which biological effects occur occasionally. The biological effect determined by a mixture of chemicals can be calculated by the mean ERM quotient (m-ERM-Q) according to Long et al. (1998). This quotient has been related to the probability of toxicity based on the analyses of matching

chemical and toxicity data from several samples from US estuaries (Long et al. 2000). A mean ERM quotient lower than 0.1 has a 9% probability of being toxic, a mean ERM quotient of 0.11–0.50 has a 21% probability of toxicity, a mean ERM quotient of 0.51–1.50 has a 49% probability of being toxic, and a mean ERM quotient higher than 1.50 has a 76% probability of toxicity.

The TEL/PEL SQGs are also applied to assess the degree to which the sediment-associated chemical status might adversely affect aquatic organisms and are designed to assist in the interpretation of sediment quality (Macdonald et al. 1996; Long et al. 1998; Macdonald et al. 2000). The threshold effects level (TEL) was interpreted to present chemical concentrations below which adverse biological effects rarely occur, and the probable effects level (PEL) was intended to present chemical concentrations above which adverse biological effects frequently occur (Macdonald et al. 2000).

The prescribed sediment quality guideline values for selective eight trace metals are furnished below:

Metals	ERL	ERM	TEL	PEL
Cr	81.00	370.00	52.30	160.40
Ni	20.90	51.60	15.90	42.80
Cu	34.00	270.00	18.70	108.20
Zn	150.00	410.00	124.00	271.00
Cd	1.20	9.60	0.68	4.20
Hg	0.15	0.17	0.13	0.70
As	8.20	70.00	7.24	41.60
Pb	49.70	218.00	30.20	112.20

Effects range low (ERL) and effects range median (ERM) are SQGs developed by Long and Morgan (1990) to categorize the range of concentrations in sediment, the effects of which are scarcely observed or predicted (below the ERL), occasionally observed (ERL–ERM), and frequently observed (above the ERM) (Long et al. 1995). The classification of environmental risk assessment indices was shown in Table 2.2.

2.5 Statistical Analyses

In order to obtain information about characteristics, relationships, associations, and the metal's behavior in sediment biota of Sundarban wetland and the Hooghly estuary, basic statistical methods, including correlation analysis, factor analysis (FA), and hierarchical cluster analysis (CA), were carried out. Data were log transformed [$\log_{10}(n + 1)$] to eliminate the influence of different units of variance and give each determined variable an equal weight (Wang et al. 2013). A percent error in a variable is actually a multiplicative factor. For example, an error of 5% means the error is typically 5/100 times the value of the variable. When taking logs, the multiplicative factor becomes an additive factor, because that is how logs work:

Table 2.2 An overview of the classification of environmental risk assessment indices

Index	Classification	Description	References
Geoaccumulation index (I_{geo})	≤ 0	Unpolluted	Muller (1981)
	0–1	Unpolluted to moderately polluted	
	1–2	Moderately polluted	
	2–3	Moderately polluted to strongly polluted	
	3–4	Strongly polluted	
	4–5	Strongly to extremely polluted	
	> 5	Extremely polluted	
Enrichment factor (EF)	< 1	No enrichment	Sakan et al. (2009)
	< 3	Minor enrichment	
	3–5	Moderate enrichment	
	5–10	Moderately severe enrichment	
	10–25	Severe enrichment	
	25–50	Very severe enrichment	
	> 50	Extremely severe enrichment	
Potential ecological risk index for the single heavy metal (E^i)	< 40	Low risk	Hakanson (1980)
	40–80	Moderate risk	
	80–160	Considerable risk	
	160–320	High risk	
	≥ 320	Very high risk	
Potential ecological risk (RI)	< 150	Low risk	Hakanson (1980)
	150–300	Moderate risk	
	300–600	Considerable risk	
	≥ 320	Very high risk	
Modified degree of contamination (mC_d)	$mC_d < 1.5$	Nil to very low degree of contamination	Abraham (2005)
	$1.5 \leq mC_d < 2$	Low degree of contamination	
	$2 \leq mC_d < 4$	Moderate degree of contamination	
	$4 \leq mC_d < 8$	High degree of contamination	
	$8 \leq mC_d < 16$	Very high degree of contamination	

(continued)

Table 2.2 (continued)

Index	Classification	Description	References
	$16 \leq mC_d < 32$	Extremely high degree of contamination	
	$mC_d \geq 32$	Ultrahigh degree of contamination	
Contamination factor (CF)	<1	Low contamination	Hakanson (1980)
	1–3	Moderate contamination	
	3–6	Considerable contamination	
	>6	Very high contamination	
Nemerow pollution load index (PI)	$PI < 0.7$	Nonpolluted sediment	Guang et al. (2010) and Qingjie et al. (2008)
	$0.7 < PI < 1$	Nearly polluted sediment	
	$1 < PI < 2$	Lightly polluted sediment	
	$2 < PI < 3$	Moderately polluted sediment	
	$3 < PI$	Seriously polluted sediment	
Mean ERM quotient (m-ERM-Q)	<0.1	9% probability of toxicity	Long et al. (2000)
	0.11–0.5	21% probability of toxicity	
	0.51–1.5	49% probability of toxicity	
	>1.51	76% probability of toxicity	
Mean PEL quotient (m-PEL-Q)	<0.1	9% probability of toxicity	Long et al. (2000)
	0.11–0.5	21% probability of toxicity	
	0.51–1.5	49% probability of toxicity	
	>1.51	76% probability of toxicity	

$\log(Y^*error) = \log(Y) + \log(error)$. The percent error therefore becomes the same additive error, regardless of the value of Y. The log transformation makes the nonuniform residuals to become uniform. This feature of log transformation is useful for most of the multivariate statistical analyses.

2.5.1 Correlation Matrix

Correlation is any of a broad class of statistical relationships involving dependence, though in common usage it most often refers to the extent to which two variables have a linear relationship with each other. Correlation, also called correlation coefficient, indicates the strength and direction of a linear relationship between two random variables. In general statistical usage, correlation or co-relation refers to the departure of two variables from independence. Correlation may be defined as a major of the strength of association between two variables measured on a number of individuals and is quantified using the Pearson product-moment coefficient of linear correlation, usually known as the correlation coefficient (Rollinson 2014). In this broad sense, there are several coefficients, measuring the degree of correlation, adapted to the nature of data. A number of different coefficients are used for different situations. The best known is the Pearson product-moment correlation coefficient, which is obtained by dividing the covariance of the two variables by the product of their standard deviations. Correlation refers to any of a broad class of statistical relationships involving dependence. Correlations are useful because they can indicate a predictive relationship that can be exploited in practice. It refers to any departure of two or more random variables from independence, but technically it refers to any of several more specialized types of relationship between mean values. The Pearson correlation coefficient indicates the strength of a linear relationship between two variables, but its value generally does not completely characterize their relationship. The sample correlation coefficient (r) is an estimate of the population correlation (ρ), i.e., the correlation that exists in the total population of which only a sample has been measured. The probability may be estimated for different levels of significance, usually at the 5% (or 0.05) level or the 1% (0.01) level (these values may also be expressed as confidence limits, as 95% or 99%, respectively) (Rollinson 2014). The significant correlation (at 5% level) is possible when r value (correlation) ≥ 0.5 and p value (Pearson correlation) ≤ 0.05 . The significant correlation (at 1% level) is possible when r value (correlation) ≥ 0.1 and p value (Pearson correlation) $0.05 \leq p \leq 0.01$.

2.5.2 Principal Component Analysis (PCA)

Principal component analysis (PCA) is a widely used statistical procedure that uses an orthogonal transformation to convert a set of observations of possibly correlated variables into a set of values of linearly uncorrelated variables called principal components (PC). By transforming the original variables into a number of PCs, the first principal component (PC1) has the largest possible variance to account for as much of the variability in the observation as possible. The succeeding component (e.g., PC2, PC3, the second and third component, etc.) has the largest variance uncorrelated with those of the previous components. All these components play a significant role to explain the variations in environmental research.

This is the simplest of the true eigenvector-based multivariate analyses, which reduces multidimensional data to lower dimensions while restoring the overall information, covering standard deviation, covariance, and eigenvectors (Karamizadeh et al. 2013). This is widely used as ordination techniques for unfolding the ecological gradients and to explore spatiotemporal trends in environmental quality megadata set. PCA's key advantages are its low noise sensitivity, the decreased requirements for capacity and memory, and increased efficiency given the processes taking place in smaller dimensions; the complete advantages of PCA are (1) lack of redundancy of data given the orthogonal components (Phillips et al. 2005; Asadi et al. 2010), (2) reduced complexity in images grouping with the use of PCA (Phillips et al. 2005; Asadi et al. 2010), (3) smaller database representation since only the trainee images are stored in the form of their projections on a reduced basis (Phillips et al. 2005), and (4) reduction of noise since the maximum variation basis is chosen and so the small variations in the background are ignored automatically (Phillips et al. 2005).

PCA technique is widely applied in environmental pollution research to identify the hypothetical source of heavy metals (natural or anthropogenic). This is performed by varimax rotation which is employed because orthogonal rotation minimizes the number of variables with a high loading on each component. This facilitates the interpretation of PCA results. This technique clusters variables into groups such that variables belonging to one group are highly correlated with one another. PCA leads to a reduction of the initial dimension of the data set to four components which explains 96.29% of the data variation. Therefore, these four factors play a significant role to explain metal contamination in the study area.

Among the statistical techniques, both principal component analysis (PCA) and cluster analysis (CA) are useful tools to discover common patterns in data distribution, leading to initial dimension reduction of data sets and helping its interpretation (Franco-Uría et al. 2009). Both the processes assist to set up analyzed parameters in different factors/groups on the basis of contribution from their possible sources. FA and PCA have been widely used to expose variable redundancy and combine variables into single factors (Wilcke et al. 1998; Chen et al. 1999; Kumru and Bakac 2003; Navas and Machin 2002; Bretzel and Calderisi 2006). CA is often coupled to FA and PCA to provide groupings of individual variables according to distances or similarity indices (Facchinelli et al. 2001; Granero and Domingo 2002; Manta et al. 2002; Wang et al. 2005; Han et al. 2006). The explanation of the above data processing helps to identify pollution sources and allocate natural vs. anthropic contribution.

PCA is designed to transform the original variables into new, uncorrelated variables (axes), called the principal components, which are linear combinations of the original variables. The new axes lie along the directions of maximum variance (Sarbu and Pop 2005). The principal component (PC) can be expressed as the following:

$$Z_{ij} = a_{i1}x_{1j} = a_{i2}x_{2j} + a_{i3}x_{3j} + \dots + a_{im}x_{mj}$$

where z is the component score, a is the component loading, x is the measured value of a variable, i is the component number, j is the sample number, m is the total number of variables

2.5.3 Dendrogram

A *dendrogram*, commonly known as a tree diagram, is a visual graphical representation of the compound correlated data, and this is very frequently used in environmental analyses or computational biology to illustrate the arrangement of the clusters produced by hierarchical clustering. The result of a clustering is presented either as the distance or the similarity between the clustered rows or columns depending on the selected distance measure (Damle and Kshirsagar, 2012). The individual compounds are arranged along the bottom of the dendrogram, known as leaf nodes. Compound clusters are formed by joining individual compounds or existing compound clusters with the join point referred to as a node. At each dendrogram node, a right and left subbranch of clustered compounds is generally obtained. The individual spots are arranged along the bottom of the dendrogram and referred to as leaf nodes and directly represented as a nested list where each component corresponds to a branch of the tree (Fig. 2.10).

The vertical axis is labeled distance and refers to a distance measure between compounds or compound clusters. The height of the node can be thought of as the distance value between the right and left subbranch clusters. The measured distance between two clusters is calculated as follows: $D = 1 - C$, where D = distance and C = correlation between compound clusters. If compounds are highly correlated,

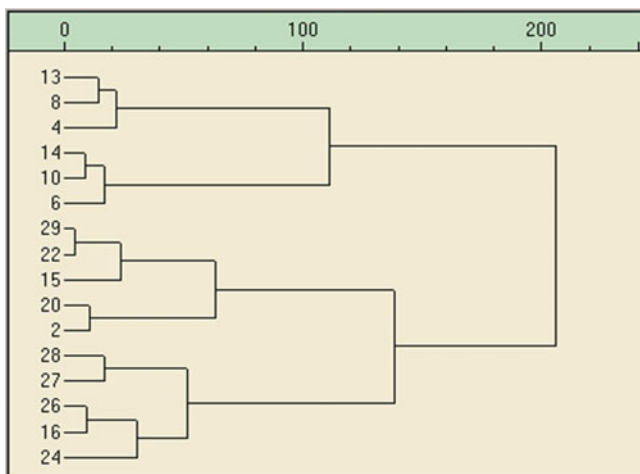

Fig. 2.10 Dendrogram showing the clustering of sampling units using Euclidean distance

the correlation value would be close to 1, and so the values of $D = 1 - C$ will be close to zero. Therefore, highly correlated clusters are nearer the bottom of the dendrogram. Compound clusters that are not correlated have a correlation value of zero and a corresponding distance value of 1. With compounds that are negatively correlated, revealing opposite nature of abundance or behavior, the value of correlation will be -1 and $D = 1 - (-1) = 2$.

The purpose of CA is to identify groups or clusters of similar sites on the basis of similarities within a class and dissimilarities between different classes (Sparks 2000). CA is a group of multivariate techniques whose primary purpose is to assemble objects based on the characteristics they possess. CA classifies objects so that each object is similar to the other. The resulting clusters of objects should then exhibit high internal (within cluster) homogeneity and high external (between clusters) heterogeneity. In this study, hierarchical agglomerative CA was performed on the normalized data set by means of the Ward's method, using squared Euclidean distances as a measure of similarity. CA was applied on experimental data standardized through z-scale transformation in order to avoid misclassification due to wide differences in data dimensionality (Liu et al. 2003).

Hierarchical cluster analysis (CCA) is the most frequently used CA for environmental analyses which groups samples on the basis of their similarities. This is a powerful statistical tool for grouping expected or unexpected clusters including the presence of outliers. The most similar points are grouped together forming a single cluster, and the process is repeated until all points belong to one cluster. This is an effective analysis showing distances between samples and data sets.

2.5.4 Factor Analysis

Factor analysis is a useful tool for investigating correlations between observed variables to estimate common factors. It allows investigating concepts that are not easily measured directly by collapsing a large number of variables into a few interpretable underlying factors. It makes use of second-order statistics to extract signal so that signal-to-noise ratio can be increased. Also, factor analysis is concerned with the dimensional (number of variables) reduction of a set of observed data in terms of small number of latent factors (Chen and Zhenhai 2006). The key concept of factor analysis is that multiple observed variables have similar patterns of responses because they are all associated with a latent (i.e., not directly measured) variable. In every factor analysis, there is the same number of factors as there are variables. Each factor captures a certain amount of the overall variance in the observed variables, and the factors are always listed in order of how much variation they explain.

The eigenvalue is a measure of how much of the variance of the observed variables a factor explains. Any factor with an eigenvalue ≥ 1 explains more variance than a single observed variable. So if the factor for socioeconomic status had an eigenvalue of 2.3, it would explain as much variance as 2.3 of the three variables. This factor, which captures most of the variance in those three variables,

could then be used in other analyses. The factors that explain the least amount of variance are generally discarded. The relationship of each variable to the underlying factor is expressed by the so-called factor loading. Here is an example of the output of a simple factor analysis looking at indicators of wealth, with just six variables and two resulting factors.

There are two types of factor analysis:

1. Exploratory factor analysis is applied if there is an idea about what structure the data have or how many dimensions are in a set of variables.
2. Confirmatory factor analysis is used for verification as long as a specific idea exists about what structure they have or how many dimensions are in a set of variables.

This is a statistical method used to describe variability among observed, correlated variables in terms of a potentially lower number of unobserved variables called factors. It is possible that variations in four observed variables mainly reflect the variations in two unobserved variables. Factor analysis searches for such joint variations in response to unobserved latent variables (Chaiya 2014). The information gained about the interdependencies between observed variables can be used later to reduce the set of variables in a data set. The main applications of factor analytic techniques are (1) to reduce the number of variables and (2) to detect structure in the relationships between variables, that is, to classify variables (Hill and Lewicki 2006).

2.5.5 Analysis of Variance (ANOVA)

Analysis of variance (ANOVA) is a statistical technique to test for significant differences between means considering the following assumptions: (1) random sampling and (2) variance associated with the variable of interest which must be the same for each population or for each data group.

Based on variations existing within the sample and variation existing between the samples, ANOVAs are used in three ways described as follows:

1. *One-way ANOVA*: A one way is the simplest type of ANOVA which refers to the number of independent variables – not the number of categories in each variable. Only one source of variation or factor is studied, with three or more samples simultaneously. This is used to test the null hypothesis that three or more treatments are equally effective.
2. *Two-way ANOVA*: A two-way ANOVA refers to an ANOVA using two independent variables which can be used to examine the interaction between the two independent variables. Interactions indicate that differences are not uniform across all categories of the independent variables.
3. *N-way multivariate ANOVA*: A researcher can use many independent variables, and this is an n-way ANOVA.

The difference between one-way ANOVA and two-way ANOVA can be attributed to the purpose for which they are used and their concepts. The purpose of one-way ANOVA is to see whether the data collected for one dependent variable are close to the common mean. On the other hand, two-way ANOVA determines whether the data collected for two dependent variables converge on a common mean derived from two categories. One-way ANOVA is used when there is only one independent variable with several groups or levels or categories, and the normally distributed response or dependent variables are measured, and the means of each group of response or outcome variables are compared. When there are two independent variables each with multiple levels and one dependent variable in question, the ANOVA becomes two way. The two-way ANOVA shows the effect of each independent variable on the single response or outcome variables and determines whether there is any interaction effect between the independent variables.

Results of the ANOVA are presented in a tabular form, which has columns labeled sum of squares (SS), df (degrees of freedom), mean square (MS), F (for F-ratio), and significance. The use of ANOVA depends on the research design.

2.5.6 Box and Whisker Plot

In descriptive statistics, a boxplot or a box-and-whisker diagram or plot is the most convenient way of graphically depicting groups of numerical data through their quartiles, which are uniform in their use. In this plot, a rectangle is drawn to represent the second and third quartiles, usually with a vertical line inside to indicate the median value. Bottom and top of the box are always the first (25%) and third quartiles (75%), and the band inside the box is always the second quartile (the median). The 25% of total value representing the minimum value of the sample and remaining 75% of total value representing maximum value of the sample indicate positive standard error in the upper end of the box and negative standard error in the lower end of the box respectively. The lower and upper quartiles are shown as horizontal lines on either side of the rectangle (Fig. 2.11).

Box-and-whisker plot can be useful to display differences between populations without making any assumptions of the underlying statistical distribution. The spacings between the different parts of the box help indicate the degree of dispersion (spread) and skewness in the data, and identify outliers. Boxplots can be drawn either horizontally or vertically. Any data observation which lies more than lower than the first quartile or higher than the third quartile is considered an outlier. Indicate where the smallest value that is not an outlier by connecting it to the box with a horizontal line or “whisker.” Optionally, also mark the position of this value more clearly using a small vertical line. Likewise, connect the largest value that is not an outlier to the box by a “whisker” (and optionally mark it with another small vertical line).

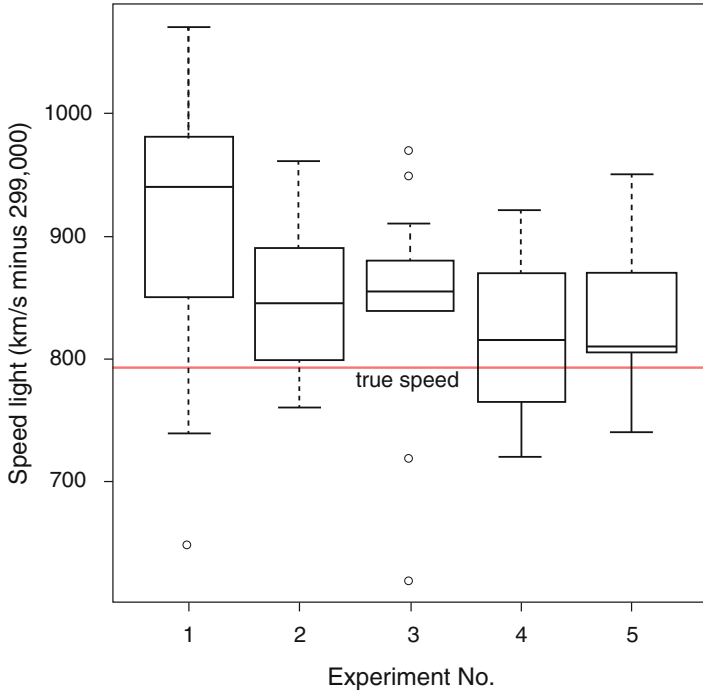

Fig. 2.11 Graphical representation of Box-and-whisker plot

Advantages of boxplots:

- (a) Graphically display a variable's location and spread at a glance.
- (b) Provide some indication of the data's symmetry and skewness.

- (c) Unlike many other methods of data display, boxplots show outliers.
- (d) By using a boxplot for each categorical variable side by side on the same graph, one quickly can compare data sets.

Disadvantages of boxplots:

- (a) They tend to emphasize the tails of a distribution, which are the least certain points in the data set.
- (b) They also hide many of the details of the distribution.

All statistical data processing in this book is carried out using commercial statistics software packages, and details of application and interpretation of the above-referred statistical tools have been described in the forthcoming chapters. This is recommended to apply log-transformed data to eliminate the influence of different units of variance and give each determined variable an equal weight (Wang et al. 2013).

2.6 Conclusion

Coastal zones in Indian Sundarban wetland and adjacent estuarine environs are potentially productive from ecological and economic point of view, but the environment is steadily degraded as these are recipients of toxic chemical compounds including trace metals and metalloids from a wide variety of point and nonpoint sources. Hence, proper and systematic monitoring of trace metal contamination (especially potentially hazardous metals) in biotic and abiotic matrices is of prime importance, employing specific analytical tools based on electrochemical, adsorption, emission, fluorescence, or X-ray properties of the concerned metals. The quality of measurements necessary for pollution monitoring programme is directly linked to a set of criteria, such as proper selection of sample site, specific type and treatment of research samples, sampling procedure, storage/preservation of the sample, and quality control of the final determination using standard analytical techniques. Multidimensional statistical treatment of the log-transformed data by applying a specific tool and their subsequent interpretations are also an important aspect for explanation and interpretation of research findings.

References

- Abraham GMS (2005) Holocene sediments of Tamaki Estuary: Characterisation and impact of recent human activity on an urban estuary in Auckland, New Zealand. Ph.D. thesis, University of Auckland, Auckland, New Zealand. 361p
- Agemian H, Chau ASY (1976) Evaluation of extraction technique for the determination of metals in aquatic sediments. *Analyst* 101:761–767
- Angula E (1996) The Tomlinson pollution index applied to heavy metal, mussel–watch data: a useful index to assess coastal pollution. *Sci Total Environ* 187:19–56

- Asadi SD, Subba Rao DV, Saikrishna V (2010) A comparative study of face recognition with principal component analysis and cross-correlation technique. *Int J Comput Appl* 10
- Bandyopadhyay S (1998) Coastal erosion and its management in Sagar Island, south 24Parganas, West Bengal. *Indian J Earth Sci* 24(34):51–69
- Banerjee K, Senthikumar B, Purvaja R, Ramesh R (2012) Sedimentation and trace metal distribution in selected locations of Sundarbans mangroves and Hooghly estuary, northeast coast of India. *Environ Geochem Health* 34(1):27–42
- Barry RG, Chorley RJ (1987) *Atmosphere, weather and climate*, 5e éd edn. Methuen, New York. 460 p
- Bhuiyan MAH, Parvez L, Islam MA, Dampare SB, Suzuki S (2010) Heavy metal pollution of coal mine-affected agricultural soils in the northern part of Bangladesh. *J Hazard Mater* 173:384–392
- Binelli A, Sarkar SK, Chatterjee M, Riva C, Parolini M, Bhattacharya BD, Bhattacharya A, Satpathy KK (2007) Concentration of polybrominated diphenyl ethers (PBDEs) in sediment cores of Sunderban mangrove wetland, northeastern part of bay of Bengal (India). *Mar Pollut Bull* 54:1220–1229
- Bretzel F, Calderisi M (2006) Metal contamination in urban soils of coastal Tuscany (Italy). *Environ Monit Assess* 118:319–335
- Campbell KR (1995) Concentrations of heavy metals associated with urban runoff in fish living in Stormwater ponds. *Arch Environ Contam Toxicol* 27:352–356
- Chaiya K (2014) A factor analysis of determining success in computer or electronic parts industries in Thailand. In: Gaol FL (ed) *Interdisciplinary behavior and social sciences: proceedings of the 3rd International Congress on Interdisciplinary Behavior and Social Science 2014 (ICIBSoS 2014)*, 1–2 November 2014, Bali, Indonesia
- Chatterjee M, Silva Filho EV, Sarkar SK, Sella SM, Bhattacharya A, Satpathy KK et al (2007) Distribution and possible source of trace elements in the sediment cores of a tropical macrotidal estuary and their ecotoxicological significance. *Environ Int* 33:346–356
- Chen CH, Zhenhai W (2006 August) ICA and factor analysis application in seismic profiling, IEEE International Conference on Geoscience and Remote Sensing Symposium, 1560–1563
- Chen M, Ma LQ, Harris WG (1999) Baseline concentrations of 15 trace elements in Florida surface soils. *J Environ Qual* 28:1173–1181
- Damle T, Kshirsagar M (2012) Role of permutations in significance analysis of microarray and clustering of significant microarray gene list. *Int J Comput Sci Issue* 9 (2:1)
- Dyer KR (1986) *Coastal and estuarine sediment dynamics*. Wiley, New York
- Facchinelli A, Sacchi E, Mallen L (2001) Multivariate statistical and GIS-based approach to identify heavy metal sources in soils. *Environ Pollut* 114:313–324
- Folk RL, Ward WC (1957) Brazos River bar[Texas]; a study in the significance of grain size parameters. *Int J Sed Res* 27:3–26
- Franco-Uría A, López-Mateo C, Roca E, Fernández Marcos ML (2009) Source identification of heavy metals in pasture by multivariate analysis in NW Spain. *J Hazard Mater* 165:1008–1015
- Gee GW, Bauder JW (1986) Particle-size analysis. In: Klute A (ed) *Methods of soil analysis*. Part 1. American Society of Agronomy, Madison, pp. 383–412
- Granero S, Domingo JL (2002) Levels of metals in soils of Alcalá de Henares, Spain: human health risks. *Environ Int* 28:159–164
- Guang X, Jian X, Yue Z, Caiyun Z, Qing W (2010) Application of Nemerow Pollution Index in landscape river water quality assessment of Tianjin, Bioinformatics and Biomedical Engineering (iCBBE). In: 4th international conference, pp 1–4
- Hakanson L (1980) An ecological risk index for aquatic pollution control: a sedimentological approach. *J Wat Res* 14:975–1001
- Han YM, Du PX, Cao JJ, Posmentier ES (2006) Multivariate analysis of heavy metal contamination in urban dusts of Xi'an, Central China. *Sci Total Environ* 355:176–186
- Hill T, Lewicki P (2006) *Statistics: methods and applications : a comprehensive reference for Science, industry, and data mining*. StatSoft, Inc.

- Janakiraman D, Jonathan MP, Srinivasalu S, Armstrong-Altrin JS, Mohan SP, Ram-Mohan V (2007) Trace metals in core sediments from Muthupet mangroves, SE coast of India: application of acid leachable technique. *Environ Pollut* 145:245–257
- Karamizadeh S, Abdullah SM, Manaf AA, Zamani M, Hooman A (2013) An overview of principal component analysis. *J Signal Inf Process* 4(03):173
- Koci V, Mlejnek M, Kochankova L (2003) Toxicological evaluation of exposed SPMD membranes. *Cent Eur J Chem* 1:28–34
- Korte NE, Fernando Q (1991) A review of As^{III} in groundwater. *Crit Rev Environ Contam* 21:1–39
- Krumbein WC, Pettijohn FJ (1938) *Manual of sedimentary petrology*. Plenum, New York, p 549
- Kumru MN, Bakac M (2003) R-mode factor analysis applied to the distribution of elements in soils from the Aydin basin, Turkey. *J Geochem Explor* 77:81–91
- Liu CW, Lin KH, Kuo YM (2003) Application of factor analysis in the assessment of groundwater quality in a Blackfoot disease area in Taiwan. *Sci Total Environ* 313:77–89
- Liu B, Hu K, Jiang Z, Yang J, Luo X, Liu A (2011) Distribution and enrichment of heavy metals in a sediment core from the Pearl River estuary. *Environ Earth Sci* 62:265–275
- Long ER, Morgan LG (1990) The potential for biological effects of sediment-sorbed contaminants tested in the National Status and Trends Program. NOAA Tech. Memo. NOS OMA 52. National Oceanic and Atmospheric Administration, Seattle. 1990:236
- Long ER, Mac Donald DD, Smith SL, Calder FD (1995) Incidence of adverse biological effects within ranges of chemical concentrations in marine and estuarine sediments. *Environ Manag* 19:81–97
- Long ER, Field LJ, MacDonald DD (1998) Predicting toxicity in marine sediments with numerical sediment quality guidelines. *Environ Toxicol Chem* 17:714–727
- Long ER, MacDonald DD, Severn CG, Hong CB (2000) Classifying the probabilities of acute toxicity in marine sediments with empirically-derived sediment quality guidelines. *Environ Toxicol Chem* 19:2598–2601
- Macdonald DD, Carr RS, Calder FD, Long ER, Ingersoll CG (1996) Development and evaluation of sediment quality guidelines for Florida coastal waters. *Ecotoxicology* 5:253–278
- MacDonald DD, Ingersoll CG, Berger TA (2000) Development and evaluation of consensus-based sediment quality guidelines for freshwater ecosystems. *Arch Environ Contam Toxicol* 39:20–31
- Manta DS, Angelone M, Bellanca A, Neri R, Sprovieri M (2002) Heavy metals in urban soils: a case of Palermo (Sicily), Italy. *Sci Total Environ* 300:229–243
- Marsh J (1836) Account of a method of separating small quantities of arsenic from substances with which it may be mixed. *Edinburgh Philos J* 21:229–236
- Müller G (1981) Die Schwermetallbelastung der sedimente des Neckars und seiner Nebenflüsse: eine Bestandsaufnahme. *Chem Zeitung* 105:157–164
- Navas A, Machin J (2002) Spatial distribution of heavy metals and arsenic in soils of Aragon (northeast Spain): controlling factors and environmental implications. *Appl Geochem* 17:961–973
- Phillips PJ, Flynn PJ, Scruggs T, Bowyer KW, Chang J, Hoffman K, Marques J, Min J, Worek W (2005) Overview of the Face Recognition Grand Challenge. In: *Computer vision and pattern recognition, 2005. CVPR 2005*. IEEE Computer Society conference on, 2005, pp. 947–954
- Qingjie, G., Jun, D., Yunchuan, X., Qingfei, W., Liqiang, Y., Calculating pollution indices by heavy metals in ecological geochemistry assessment and a case study in parks of Beijing. *J China Univ Geosci* 19 (2008) 230–241.
- Qinna Z, Qixin X, Kai Y (2005) Application of potential ecological risk index in soil pollution of typical polluting industries. *J East China Norm Univ Nat Sci* 1:110–115
- Rakshit D, Biswas SN, Sarkar SK, Bhattacharya BD, Godhantaraman N, Satpathy KK (2014) Seasonal variations in species composition, abundance, biomass and production rate of tintinnids (Ciliata: protozoa) along the Hooghly (Ganges) river estuary, India: a multivariate approach. *Environ Monit Assess* 186(5):3063–3078
- Rollinson HR (2014) *Using geochemical data: evaluation, presentation, interpretation*. Routledge

- Sakan SM, Djordjevic DS, Manojlovic DD, Polic PS (2009) Assessment of heavy metal pollutants accumulation in the Tisza river sediments. *J Environ Manag* 90:3382–3390
- Sarbu C, Pop HF (2005) Principal component analysis versus fuzzy principal component analysis. A case study, the quality of Danube water 1985-1996. *Talanta* 65:1215–1220
- Sarkar SK, Bhattacharya B, Das R (2003) Seasonal variations and inherent variability of selenium in marine biota of a tropical wetland ecosystem: implications for bioindicator species. *Ecol Indicat* 2(4): 367–375. Elsevier Press, Oxford
- Sarkar SK, Saha M, Takada H, Bhattacharya A, Mishra P, Bhattacharya B (2007) Water quality management in the lower stretch of the river Ganges, east coast of India: an approach through environmental education. *J Clean Prod* 15:65–73
- Song Y, Choi MS (2017) Assessment of heavy metal contamination in sediments along the coast of South Korea using Cs-normalized background concentrations. *Mar Pollut Bull* 117:532–537
- Soto EG, Rodriguez EA, Fernandez EF, Rodriguez DP (1996) Review: analytical methods for arsenic speciation in environmental samples. *Cienc* 4:149–164
- Sparks T (2000) *Statistics in ecotoxicology*. Wiley, Chichester
- Turekian KK, Wedepohl KH (1961) Distribution of the elements in some major units of the earth's crust. *Bull Geol Soc am* 72:175–192
- Voutsinou-Taliadouri F, Varnavas SP (1995) Geochemical and sedimentological patterns in the Thermaikos Gulf, North-West Aegean Sea, formed from multisource of elements. *Estuar Coast Shelf Sci* 40:295–320
- Walkey A, Black TA (1934) An examination of the Dugtijaraff method for determining soil organic matter and proposed modification of the chronic and titration method. *Soil Sci* 37:23–38
- Wang XS, Qin Y, Sang SX (2005) Accumulation and sources of heavy metals in urban topsoils: a case study from the city of Xuzhou, China. *Environ Geol* 48:101–107
- Wang ZH, Feng J, Jiang T, Gu YG (2013) Assessment of metal contamination in surface sediments from Zhelin Bay, the South China Sea. *Mar Pollut Bull* 76:383–388
- Wilcke W, Muller S, Kanchanakool N, Zech W (1998) Urban soil contamination in Bangkok: heavy metal and aluminum partitioning in topsoils. *Geoderma* 86:211–228
- Zhou HY, Peng XT, Pan JM (2004) Distribution, source and enrichment of some chemical elements in sediments of the Pearl River estuary. *China Cont Shelf Res* 24:1857–1875

Abstract

The chapter presents a comprehensive account regarding concentration, distribution, and possible pollution sources of selected trace elements in the surface sediment samples (top 0–10 cm; <63 μm in grain size) collected from the intertidal regions of the meso- macrotidal estuarine complex covering Sundarban mangrove wetland (SWM) and Hooghly River Estuary (HRE), eastern part of India. The total concentrations of the elements (expressed in $\mu\text{g g}^{-1}$ dry weight) showed a wide range of variations as follows: Al 7563.61–64,012.77, Fe 8326.24–44,653.68, Mn 143.49–728.08, V 13.25–93.43, Cr 11.58–82.75, Co 3.22–17.97, Ni 7.80–52.81, Cu 5.82–53.72, Zn 19.70–118.95, Pb 2.90–24.06, Cd 0.01–0.45, and As 1.85–10.66. Their distribution was likely to be determined by sediment transport pathways, hydrodynamic conditions, and input from point and nonpoint sources. The concentration of all elements (except Cd) was found to be maximum at the sampling site Frazergunj; hence, it can be identified as a “hot spot.” Assessment using consensus-based sediment quality guidelines (SQGs) indicates that the concentrations of Ni have exceeded both ERM and PEL values which might result in frequent harmful effects on sediment-dwelling organisms. At the sampling site Budge Budge in HRE, both geoaccumulation index (I_{geo}) and enrichment factor ($\text{EF}_{\text{Cd}} = 2.68$) values revealed significant pollution by Cd which might have been derived from anthropogenic sources. However, the mean ecological risk index ($\text{RI} = 31.39 \pm 12.21$) indicated low ecological risk for this estuarine environment. Pearson correlation showed significant positive correlation between elements and also good correlation of elements with finer fractions in sediments.

Keywords

Trace elements • Environmental assessment • Hooghly River Estuary • Sundarban mangrove wetland • Intertidal region

3.1 Introduction

Coastal zone interfacing between the land and oceans is extremely sensitive to environmental and human-induced changes (Clabby 2010; Wang et al. 2014; Xu et al. 2016a). These fragile environs are the “sink” for continents as they constantly receive and concentrate pollutants and other negative consequences of developmental activities taking place in the surroundings (Gao and Chen 2012; Chakraborty 2017). Trace metal contamination has attained a global attention and is considered a serious threat due to their environmental persistence, non-degradability, biogeochemical recycling, and ecotoxicological risks through transfer in food chain (Diagomanolin et al. 2004; Xu et al. 2015a, b, 2016b; Forstner and Wittmann 1979; Sakan et al. 2006; Yang et al. 2012). Coastal regions are considered of high biological production coupled with high biodiversity. However, their enormous ecosystem services are highly affected due to recipient of a wide range of inorganic and organic pollutants (Holder 2002; Gredilla et al. 2015).

Trace metals may originate from various point and non-point sources in the environment, including industrial pollution, atmospheric deposition, river or ocean transportation, nonpoint sources, and natural geochemical processes (Liu et al. 2015). The anthropogenic input of metallic elements, particularly from rapid economic development in coastal regions, results in severe environmental problems in marine ecosystems (Daskalakis and O'Connor 1995; Zhang and Liu 2002; Ruiz et al. 2005; Xu et al. 2014, 2015a, b).

The intertidal zones are complex and dynamic environment, where physical, chemical, and biological interactions between continents and marine systems have profound influence on the transport and fate of trace metals (Lau and Chu 2000; Spencer 2002; Zhang and Gao 2015). Therefore, intertidal sediment is identified as one of the major reservoirs of heavy metals originated from both natural and anthropogenic sources, and it also plays a significant role in the biogeochemical cycling of metals (Duran et al. 2008; Ding et al. 2009; Zhang and Gao 2015).

Sediments exhibit a great capacity to accumulate trace metals at even low concentrations in aquatic environments (Christophoridis et al. 2009; Hu et al. 2013). Thus, temporal and spatial surveys of inorganic contaminants in sediments are useful for assessing pollution in the marine environment and for providing basic information for the determination of environmental health risks (Li et al. 2012; Hu et al. 2013). Unfortunately, such information is not sufficient in the coastal areas of West Bengal, eastern part of India (Watts et al. 2013; Sarkar et al. 2012; Antizar-Ladislao et al. 2015; Corsolini et al. 2012). Hence, the present study has been undertaken with the following objectives: (1) to determine the concentrations and distributions of elements in surface sediment along the coastal regions of West Bengal and (2) to assess the ecological risks posed by the elements to the environment.

3.2 Materials and Methods

3.2.1 Study Site

The Hooghly River Estuary (HRE), the first deltaic offshoot of the Ganges River, is an urban, industrialized, mixohaline-positive estuary with shallow depth (average ~6 m) and drains a catchment area of 6×10^4 km². The catchment area of HRE is highly urbanized, with commercial, light industrial, and domestic land use areas. This is a well-mixed estuary due to its shallow depth and intense tidal mixing, experiencing semidiurnal tides (maximum and minimum range of 5.5 m at spring and 1.8 m at neap, respectively). This globally significant estuary provides perpetual supply of water to the plains of West Bengal for multipurpose activities (such as irrigation, navigation of small ships and fishing boats, human and industry consumption together with fishing) and thus supporting the lives of millions of people. The increasing population density is accompanied by severe environmental stress on the river. There are influxes of effluent from diverse anthropogenic activities (including multifarious industries, sewage runoff, boat building and repair yards, paper recycling plant, and heavy vehicular and maritime traffic) into the river.

A significant ecological change is pronounced in this area due to huge discharges of untreated or semi-treated domestic and municipal sewage as well as effluents from multifarious industries carried by rivers as well as contaminated mud disposal from harbor dredging. The sedimentation accumulation rate in HRE and Indian Sundarban is ~3.0–4.8 mm year⁻¹ (Banerjee et al. 2012) which can cause a change in the geochemical characteristics of the surface sediments on an annual scale as endorsed by other workers (Liu et al. 2011).

The Indian Sundarban, the largest prograding tide-dominated megadelta in the estuarine phase of the tidal Hooghly River of an area 9630 km², is situated in the low-lying, humid, and tropical setup. The delta showed a large variety of morphological and depositional features, reflecting variations in river discharge regime, geological structure, and coastal energy conditions. These form highly productive ecological niches inhabited by a wide variety of fauna and flora. This coastal environment suffers from environmental degradation due to rapid human settlement, tourism and port activities, and operation of mechanized boats, deforestation, and increasing agricultural and aquaculture practices.

The region is impacted by substantial human activity and is the recipients of heavy metal discharges. The upstream of the Hooghly River flows through some of the most industrialized and urbanized (megacity Calcutta and Howrah) regions which make it one of the highly human-impacted rivers in India. Therefore, this study area is ideal for investigating the trace element distribution and assessing the pollution level of the region. Both the Hooghly estuary and Sundarban wetland play an important role in economic development and natural environmental evolution. The results of this study would provide a useful aid for sustainable coastal management in the region.

Thirteen sampling sites, almost equidistant from each other, have been chosen along the stretches of the HRE covering ~150 km [namely, Chandannagar (S₁),

Budge Budge (S₂), Nurpur (S₃), Diamond Harbour (S₄), Lot 8 (S₅), and Phuldubi (S₆) and six samplings sites from the adjacent Sundarban mangrove environment [Canning (S₇), Basanti (S₈), Frazergunj (S₉), Herobhanga (S₁₀), Netidhopani (S₁₁), Gona (S₁₂), and Gangasagar (S₁₃)]. The sampling sites were selected considering the sediment dispersal patterns along the drainage network systems. They are representative of the variable environmental and energy regimes that cover a wide range of substrate behavior, wave–tide climate, and intensity of bioturbation (animal–sediment interaction), geomorphological–hydrodynamic regimes, and distances from the sea (Bay of Bengal). They belong to a lower deltaic plain experiencing intense semidiurnal tides and wave action with a meso-macrotidal setting (3–6-m amplitude).

The major environmental problem of estuaries is the contaminants they receive from different sources. These wastes are carried away from upstream by the tidal current and deposited downward in the estuarine complex of Hooghly River and the associated mangroves of Sundarban. Mangrove forests are important in intertidal ecosystems that cover approximately 1.7×10^5 km² of the tropical and subtropical regions of the world (Valiela et al. 2001; Krauss et al. 2008; Chai et al. 2015).

3.2.2 Sediment Collection and Pretreatment

The surface (0–10 cm) sediments were collected during ebb tide from 6 estuarine to 7 coastal sampling sites covering Sundarban coastal regions and the adjacent Hooghly estuary. Sediments were collected using plastic spatula and sealed in acid-rinsed polyethylene bags with no head space and temporarily kept in a cooler box with ice packs at 4 °C to prevent changes in chemical composition among different phases. The sediments were stored at –20 °C until further analysis. Samplings were at least triplicated at each location to ensure the representativeness of the samples. During sample collection, a handheld global positioning system (GPS) was used to locate the sampling sites. An aliquot of each sample was lyophilized at 330 mTorr and –82.2 °C in a VirTis apparatus (Telstar, Spain) for 48 h. A portion of the dried sample was sieved through a 63- μ m mesh for homogenization and stored in sealed plastic bags. A fraction of fresh unsieved sample was separated for determining the sediment quality parameters like organic carbon and grain-size fraction.

3.2.3 Physicochemical Analysis of Sediments

The organic carbon ($C_{\text{org}}\%$) content of the sediments was determined with a rapid titration method (Walkey and Black 1934). The grain-size analyses were done by separating the sand fraction by wet sieving using a 63- μ m mesh sieve. The silt (4–63 μ m) and clay (<4 μ m) fractions were determined using the pipette method (Gee and Bauder 1986) in which a sample suspension is prepared using sodium hexametaphosphate as the dispersing agent, and aliquots are pipetted at different

time intervals and from different depths and dried and weighed for mass determination, and statistical computation of textural parameters was done by using formulae of Folk and Ward (1957). Textural classification of the sediment samples was based on the relative percentages of clay ($<4\ \mu\text{m}$), silt ($4\text{--}63\ \mu\text{m}$), and sand ($>63\ \mu\text{m}$).

3.2.4 Sample Digestion and Analytical Protocol

0.25 g of dry, grounded, and sieved sediment samples were taken in PTFE digestion vessels. The samples were digested in a closed microwave system in acid digestion mixture of 1 ml HNO_3 (MERCK) and 3 ml HCl. The solution was transferred to polypropylene tubes after centrifuge, and subsequently the concentration of trace metals was analyzed with the help of inductively coupled plasma atomic emission spectroscopy (ICP-AES) under the following operational conditions: auxiliary gas flow $0.2\ \text{l}\ \text{min}^{-1}$ and plasma power of 1300 W. For mercury, ~ 1 g of sample was digested using 20 ml of aqua regia 0% solution in a closed system, and the concentration was determined by CV-AAS after SnCl_2 solution. For quality assurance, marine sediment standard reference material, PACS-2 (National Research Council of Canada), was simultaneously analyzed with the metal analysis. The standard deviation of metal concentrations was consistent with these indicated in standard reference material.

3.2.5 Assessment of Sediment Quality Guidelines (SQGs)

Effects range low (ERL) and effects range median (ERM) are SQGs developed by Long and Morgan (1990) to categorize the range of concentrations in sediment, the effects of which are scarcely observed or predicted (below the ERL), occasionally observed (ERL–ERM), and frequently observed (above the ERM) (Long et al. 1995). The TEL/PEL SQGs are also applied to assess the degree to which the sediment-associated chemical status might adversely affect aquatic organisms and are designed to assist in the interpretation of sediment quality (Macdonald et al. 1996, 2000; Long et al. 1998). The threshold effects level (TEL) was interpreted to present chemical concentrations below which adverse biological effects rarely occur, and the probable effects level (PEL) was intended to present chemical concentrations above which adverse biological effects frequently occur (Macdonald et al. 2000).

3.2.6 Assessment of Sediment Contamination and Ecological Risks

For interpretation of data, choice of background values plays an important role (Memet 2011). The best alternative is to compare concentrations between contaminated and mineralogically and texturally comparable, uncontaminated

sediments (Rubio et al. 2000). Since there were no data on background concentrations for the studied coast sediment and soils of areas, the background values used in this paper were the average shale value (Turekian and Wedepohl 1961).

3.2.6.1 Enrichment Factor

The enrichment factor for the trace elements was worked out adopting the following equation (Herut and Sandler 2006):

$$EF = \frac{(\text{Metal/Fe})_{\text{Sample}}}{(\text{Metal/Fe})_{\text{Background}}}$$

EF values lower than 1.5 indicate that the metal is entirely provided from crustal contribution, and values higher than 1.5 indicate that a significant portion of the element is from non-crustal sources (Herut and Sandler 2006).

In this study, iron (Fe) was used as the reference element for geochemical normalization because of the following reasons: (1) it is associated with fine solid surfaces; (2) its geochemistry is homologous to many trace metals; and (3) its natural concentration tends to be uniform (Bhuiyan et al. 2010).

3.2.6.2 Geoaccumulation Index (I_{geo})

The geoaccumulation index (I_{geo}) is a powerful tool for calculation of the abundance and pollution levels of trace metals in sediment. It is determined using the following formula (Müller 1969):

$$I_{\text{geo}} = \log_2(C_n / 1.5 * B_n)$$

where C_n is the concentration of metals measured in sediment samples and B_n is the geochemical background concentration of the metal (n) which is the same as those used in the aforementioned enrichment factor calculation. Factor 1.5 is the background matrix correction factor due to lithospheric effects (Müller 1969). The geoaccumulation index consists of seven classes: $I_{\text{geo}} \leq 0$ (class 0, practically uncontaminated), $0 < I_{\text{geo}} \leq 1$ (class 1, uncontaminated to moderately contaminated), $1 < I_{\text{geo}} \leq 2$ (class 2, moderately contaminated), $2 < I_{\text{geo}} \leq 3$ (class 3, moderately to heavily contaminated), $3 < I_{\text{geo}} \leq 4$ (class 4, heavily contaminated), $4 < I_{\text{geo}} \leq 5$ (class 5, heavily to extremely contaminated), and $I_{\text{geo}} > 5$ (class 6, extremely contaminated).

3.2.6.3 Potential Ecological Risk Factor (RI)

E_r^i is an index of ecological risk assessment developed by Hakanson (1980) and widely used to evaluate the degree of pollution of trace metals in the sediments.

Following are the equations in calculating E_r^i :

$$C_f^i = C_s^i / C_n^i \quad (3.1)$$

$$E_r^i = T_r^i \times C_f^i \quad (3.2)$$

$$RI = \Sigma E_r^i \quad (3.3)$$

where RI is the sum of potential risk of individual heavy metal, E_r^i is the potential risk of individual heavy metal, T_r^i is the toxic response factor for a given heavy metal, C_f^i is the contamination coefficient, C_s^i is the present concentration of heavy metals in sediments, and C_n^i is the average shale value heavy metal concentration in sediments. Hakanson (1980) defined five categories of E_r^i (low risk, $E_r^i < 40$; moderate risk, $40 \leq E_r^i < 80$; considerable risk, $80 \leq E_r^i < 160$; high risk, $160 \leq E_r^i < 320$; very high risk, $E_r^i \geq 320$) and four categories of RI (low risk, $RI < 150$; moderate risk, $150 \leq RI < 300$; considerable risk, $300 \leq RI < 600$; very high risk, $RI \geq 600$).

3.2.7 Statistical Analysis

The logarithm-transformed data [$\log_{10} (n + 1)$] were applied to eliminate the influence of different units of variance and give each determined variable an equal weight (Wang et al. 2013). Correlations were calculated using Pearson correlation coefficient (Sokal and Rohlf 1981) to analyze the relationships among all the variables for each sampling site. One-way analysis of variance (ANOVA) was performed to establish the relationships between the elements and variation between the sampling sites using the statistical software Minitab 13. Hierarchical cluster analysis (HCA) was performed with squared Euclidean distances as a measure of similarity. Principal component analysis (PCA) was performed using XLSTAT 14 software.

3.3 Results and Discussion

3.3.1 Sediment Geochemical Characteristics

The geochemical characteristics of sediments are summarized in Table 3.1. The pH values of the surface sediment varied from slightly acidic at Budge Budge (6.96) to slightly basic in nature. The slightly acidic pH observed during the dry pre-monsoon season might be due to the decomposition of organic matter and subsequent formation of carbonic acid (Ahmad et al. 1996; Dhanakumar et al. 2013). Organic carbon ($C_{org}\%$) content ranged from 0.15% at Nurpur (S_3) to 0.81% at Herobhanga (S_{10}), and such low values might be the result of marine sedimentation and mixing processes at the sediment water interface where the rate of delivery as well as rates of degradation by microbial-mediated processes can be high (Antizar-Ladislao et al. 2015). Very low content of $C_{org}\%$ in intertidal sediments

Table 3.1 Geochemical characteristics of the sediments along Hooghly River Estuary (HRE) and adjacent Sundarban mangrove wetland

Sampling sites	pH	C_{org} (%)	Grain-size fractions			Texture
			Sand% ($>63 \mu\text{m}$)	Silt% ($4-63 \mu\text{m}$)	Clay% ($<4 \mu\text{m}$)	
Chandannagar (S1)	7.49	0.51	17.77	32.2	50.03	Clayey fine
Budge Budge (S2)	6.96	0.36	15.95	27.43	56.63	Clayey fine
Nurpur (S3)	7.28	0.15	10.14	33.35	56.51	Clayey fine
Diamond Harbour (S4)	7.63	0.42	19.16	24.10	56.74	Clayey fine
Lot 8 (S5)	7.16	0.42	6.57	32.33	61.10	Clayey very fine
Phuldubi (S6)	7.26	0.15	0.75	48.60	50.65	Silty clay
Canning (S7)	7.02	0.36	1.80	14.40	83.80	Clay
Basanti (S8)	7.19	0.18	0.90	23.03	76.08	Clay
Frazergunj (S9)	7.21	0.48	2.40	36.75	60.85	Clay
Herobhanga (S10)	7.24	0.81	1.80	27.60	70.60	Clayey very fine
Netidhopani (S11)	7.55	0.45	2.30	58.20	39.50	Silty clay loam
Gona (S12)	7.48	0.54	3.30	53.70	43.00	Silty clay
Gangasagar (S13)	7.57	0.66	97.71	0.50	1.79	Sandy

of Sundarban had already been recorded and related to the poor absorption capacity of organic compounds to negatively charged quartz grains, which predominate in this estuarine environment (Sarkar et al. 2004; Chatterjee et al. 2007). The $C_{org}\%$ fluctuated among the sediment samples with no regular distribution pattern. The sediment contained admixtures of sand, silt, and clay-size particles. Textural composition exhibited wide variations from clayey very fine to sandy. The sand, silt, and clay content varied from 0.9% to 97.17%, 0.5% to 58.2%, and 1.76% to 83.8%, respectively. The spatial variation in grain-size distribution reflects changes in the hydraulic environment. The dominance of fine fraction (clay + silt) in all the sampling sites except Gangasagar (S_{13}) suggested that lower-energy settings are prevalent in this estuarine system, whereas higher sand content ($>97\%$) at the sampling site S_{13} reflects the higher-energy environment within the fluvial–estuarine system.

3.3.2 Distribution of Trace Elements in Sediments

Descriptive statistics of concentration of the elements including mean \pm standard deviations, maximum, minimum, and shale values are shown in Table 3.2. The total concentrations (expressed in $\mu\text{g g}^{-1}$ dry weight) showed a wide range of variations

Table 3.2 Concentration of elements, maximum, minimum, mean, standard deviation (SD), and median (in $\mu\text{g g}^{-1}$) in the intertidal surface sediments along Hooghly River Estuary (HRE) and Sundarban mangrove wetland

Sampling sites	Al	Fe	Mn	V	Cr	Co	Ni	Cu	Zn	Pb	Cd	As
Chandannagar (S1)	32,699.90	30,043.30	475.15	57.87	42.71	11.97	29.67	41.24	91.71	15.69	0.18	6.88
Budge Budge (S2)	28,357.46	26,664.63	532.03	50.64	39.50	10.65	25.88	24.39	69.09	12.28	0.45	6.02
Nurpur (S3)	36,797.24	31,799.70	622.09	58.84	50.67	12.62	32.55	33.64	79.26	14.06	0.25	6.34
Diamond Harbour (S4)	25,727.48	26,528.52	524.63	44.14	35.02	10.85	25.96	24.78	65.74	10.99	0.16	5.12
Lot 8 (S5)	53,280.69	38,430.92	626.66	81.16	66.47	15.05	40.50	39.69	95.35	18.88	0.12	9.02
Phuldubi (S6)	40,901.75	38,967.74	714.71	62.96	59.12	15.71	43.64	44.96	106.57	19.50	0.12	8.85
Canning (S7)	28,434.57	26,353.18	552.53	47.33	41.54	9.76	26.42	38.28	69.49	12.44	0.07	6.53
Basanti (S8)	23,097.48	34,336.63	559.08	38.06	43.94	14.65	39.32	46.17	102.90	20.59	0.07	7.65
Frazergunj (S9)	64,012.77	44,653.68	728.08	93.43	82.75	17.97	52.81	53.72	118.95	24.06	0.09	10.66
Herobhanga (S10)	51,741.56	37,781.20	436.88	79.36	70.64	14.69	44.41	39.45	99.38	18.37	0.05	7.71
Netidhopani (S11)	47,124.74	37,432.64	410.78	73.61	66.72	13.27	39.79	41.99	95.67	17.88	0.07	8.84
Gona (S12)	37,049.66	34,372.81	608.65	60.84	60.54	12.96	37.94	40.94	83.32	16.60	0.07	9.03
Gangasagar (S13)	7563.61	8326.34	143.49	13.25	11.58	3.22	7.80	5.82	19.70	2.90	0.01	1.85
Maximum	64,012.77	44,653.68	728.08	93.43	82.75	17.97	52.81	53.72	118.95	24.06	0.45	10.66
Minimum	7563.61	8326.34	143.49	13.25	11.58	3.22	7.80	5.82	19.70	2.90	0.01	1.85
Mean ($n = 13$) \pm SD	36,676 \pm 14,949	31,976 \pm 9030	533 \pm 151	58 \pm 20	51 \pm 18	12 \pm 3	34 \pm 11	36 \pm 12	84 \pm 25	15 \pm 5	0.13 \pm 0.12	7 \pm 2
Shale value ^a	80,000.00	47,200.00	850.00	130.00	90.00	19.00	68.00	45.00	95.00	20.00	0.30	13.00
ERL ^b	–	–	–	–	81.00	–	20.90	34.00	150.00	46.70	1.20	8.20
ERM ^b	–	–	–	–	370.00	–	51.60	270.00	410.00	–	9.60	70.00
TEL ^c	–	–	–	–	52.30	–	15.90	18.70	124.00	30.20	0.68	7.24

(continued)

Table 3.2 (continued)

Sampling sites	Al	Fe	Mn	V	Cr	Co	Ni	Cu	Zn	Pb	Cd	As
PEL ^c	-	-	-	-	160.00	-	42.80	108.00	271.00	112.00	4.20	41.60
>ERL	-	-	-	-	1(7.7%)	-	12 (92.3%)	9 (69.2%)	0	0	0	5 (38.4%)
>ERM	-	-	-	-	0	-	1(7.7%)	0	0	0	0	0
>TEL	-	-	-	-	6(46%)	-	12 (92.3%)	12 (92.3%)	0	0	0	7 (53.8%)
>PEL	-	-	-	-	0	-	3(23%)	0	0	0	0	0

The effect-based SQGs are also listed. Numbers in the parentheses are percentages of sampling sites that exceeded the SQGs

The bold values indicate the maximum concentration of trace elements

^aAverage shale value. Turekian and Wedepohl (1961)

^bERL effects range low, ERM effects range median. Long et al. (1995)

^cTEL threshold effects level, PEL probable effects level. Macdonald et al. (1996)

with Al, 7563.61–64,012.77; Fe, 8326.24–44,653.68; Mn, 143.49–728.08; V, 13.25–93.43; Cr, 11.58–82.75; Co, 3.22–17.97; Ni, 7.80–52.81; Cu, 5.82–53.72; Zn, 19.70–118.95; Pb, 2.90–24.06; Cd, 0.01–0.45; and As, 1.85–10.66. The significant spatial variations of total metal concentrations in sediments were analyzed with one-way analysis of variance (ANOVA) ($F = 663.65$; $p < 0.05$). The mean concentration (expressed in $\mu\text{g g}^{-1}$) of the elements in surface sediments collected from the coastal regions of West Bengal was ranked in the following decreasing order: Al ($36,676 \pm 14,949$) > Fe ($31,976 \pm 9030$) > Mn (533 ± 151) > Zn (84 ± 25) > V (58 ± 20) > Cr (51 ± 18) > Cu (36 ± 12) > Ni (34 ± 11) > Pb (15 ± 5) > Co (12 ± 3) > As (7 ± 2) > Cd (0.13 ± 0.12). The inconsistent, anomalous trend of distribution and spatial heterogeneity of the 12 elements were very much pronounced which might be attributed to (1) location of the sampling sites along HRE and adjacent Sundarban mangrove wetland experiencing different tidal and geomorphic settings and differences in hydrodynamic regimes, (2) natural variability including intricate physical and chemical processes, (3) variations in sediment particle size (clayey very fine to sandy), and (4) nonhomogeneous inputs from point and nonpoint sources of the elements. The mean concentrations of all the elements were lower than the average shale value as proposed by Turekian and Wedepohl (1961). The sampling site Gangasagar (S_{13}) had sandy texture (97.7% sand) which can be associated to the minimum concentrations of all the elements; after all elements are generally associated to finer sediment parcels. Frazergunj (S_9), a prime fish landing site located in Sundarban, had the maximum concentration for all the elements except Cd. The synchronous elevation in the concentrations of the elements at the sampling site S_9 might be attributed to anthropogenic stresses such as boating and fishing activities, tourism and port activities, operation of mechanized boats, runoff from nearby agricultural fields, etc. It is worthy to mention that with the exception of sampling site Budge Budge (S_2) where the concentration ($0.45 \mu\text{g g}^{-1}$) of Cd was very high, the concentrations at all the other sampling sites did not exceed $0.20 \mu\text{g g}^{-1}$. The high value of Cd might be due to manufacture and application of phosphate fertilizers, fossil fuel combustion and disposal of industrial and domestic waste, edible oil refining industry, and boating activities.

3.3.3 Assessment of Element Toxicity with Empirical SQGs

The total metal concentration data obtained were assessed by two empirical SQGs (ERL and ERM and TEL and PEL), and the comparison results are shown in Table 3.2. Comparison with the empirical SQGs showed that in the 13 sampling sites, the concentration for Cr at 7.7% and 46.0%, Ni at 92.3%, Cu at 69.2% and 92.6%, and As at 38.4% and 53.8% of the sampling sites has exceeded the ERL and TEL values, respectively, indicating that adverse biological effects would rarely occur. In addition, Ni concentration exceeded the ERM and PEL values at 7.7% and 23.0% of the sampling sites, respectively, indicating adverse biological effects might occur frequently.

3.3.4 Assessment of Sediment Contamination

3.3.4.1 Enrichment Factor (EF)

To detect the contamination of the elements and quantify the possible anthropogenic impacts, EF was calculated for each selected element and sampling site, as shown in Fig. 3.1. The results showed that the EF values of the elements followed the following order: Zn > Cu > Pb > Co > Mn > V > Cr > As > Ni > Cd > Al. All the EFs calculated were lower than 1.5 ($EF < 1.5$) indicating that the elements might entirely be derived from crustal combination or through natural weathering. However, EF values of Zn and Cd at the sampling sites Chandannagar (S_1) and Budge Budge (S_2), respectively, were higher than 1.5, suggesting that these elements were influenced by anthropogenic sources such as disposal of industrial and domestic sewage, use of phosphate fertilizers in the nearby agricultural fields, use of antifouling paints, etc.

3.3.4.2 Geoaccumulation Index (I_{geo})

According to Müller scale, the results of I_{geo} (Fig. 3.2) characterized the sediments as practically “uncontaminated” with the studied elements at all the sampling sites as all the values of I_{geo} were less than 0. However, I_{geo} value of Cd (0.01) suggested

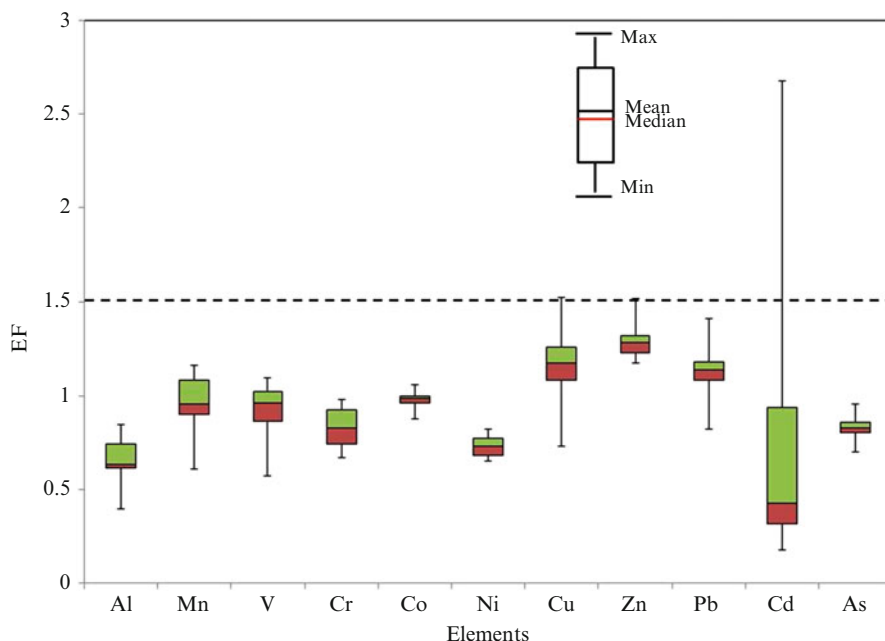

Fig. 3.1 Enrichment factors of the studied elements in the intertidal surface sediments along HRE and adjacent Sundarban mangrove wetland using Fe as normalizer. Values in the section below the bottom *dot line* ($EF < 1.5$) suggest that the elements may be entirely from crustal materials or natural weathering processes

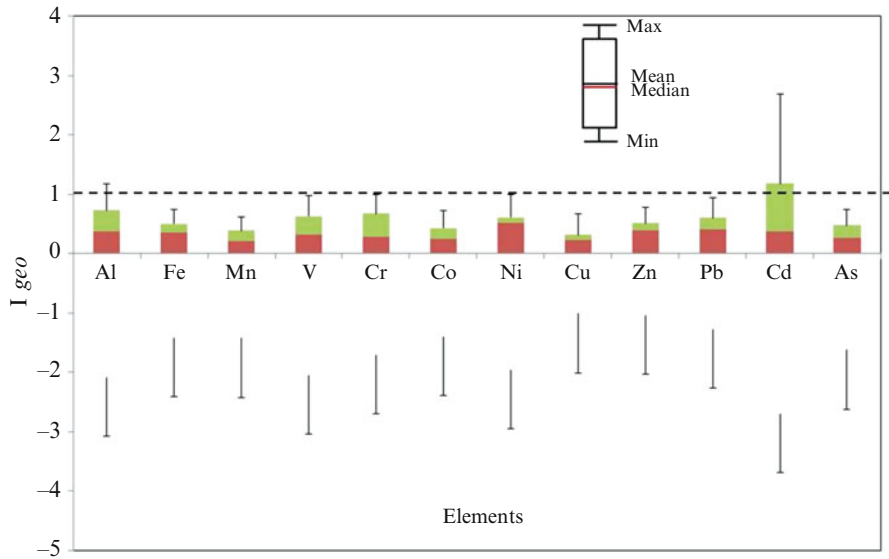

Fig. 3.2 Geoaccumulation index of the elements for the 13 sampling sites. Values in the section below the bottom *dot line* ($I_{geo} < 0$) indicate that the elements were at a practically unpolluted level; values in the section between the two *dot lines* ($0 \leq I_{geo} < 1$) indicate that the elements were at an unpolluted to moderately polluted level

that the sediment from the sampling site Budge Budge (S_2) was “uncontaminated to moderately contaminated” ($0 < I_{geo} \leq 1$) by this element.

3.3.4.3 Ecological Risk Assessment

Figure 3.3 shows the E^i_r and RI calculated considering seven elements (Cr, Ni, Cu, Zn, Pb, Cd, and As) as the biological toxic response factor (T^i_r) for other elements was unavailable. The ecological risk posed by the individual elements at each sampling site was considered to be low ($E^i_r < 40$) except for Cd at the sampling site Budge Budge (S_2), where it showed moderate risk ($40 \leq E^i_r \leq 8$). The E^i_r values of Cd varied from 0.94 at Gangasagar (S_{13}) to 45.38 at Budge Budge (S_2) with a mean of 5.59, indicating that it had a low ecological risk, in general. However, the combined effect of all the elements exhibited RI values less than 150 ($RI < 150$), indicating that the surface sediments at all the sampling sites posed low ecological risk to the environment.

3.3.5 Statistical Evaluation

3.3.5.1 Correlation Between the Elements

The correlation matrix for the concentrations of the elements and sediment geochemical characteristics are shown in Table 3.3. There were significant positive

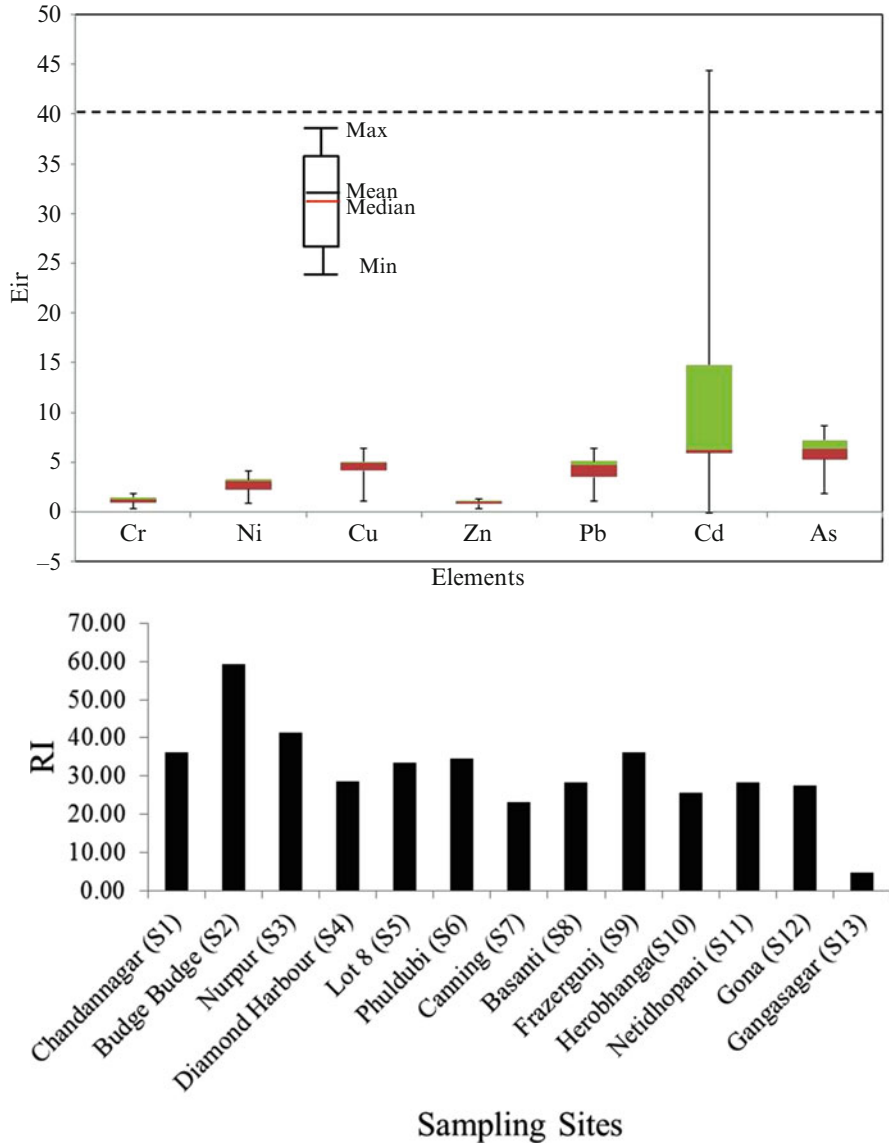

Fig. 3.3 E_{ir}^i value of each element in the studied area (left) and RI value of the studied elements for each station (right). For E_{ir}^i values, these in the section below the dot line ($E_{ir}^i < 40$) indicate that the potential ecological risks of the studied elements in the sediments were at a low level. For RI values, these in the section below $RI < 150$ indicate that the combined potential ecological risk of the studied elements in the sediments was at a low level

Table 3.3 Pearson correlation showing intermetallic relationship

	Al	Fe	Mn	V	Cr	Co	Ni	Cu	Zn	Pb	Cd
Fe	0.94**										
	0.000										
Mn	0.79**	0.89**									
	0.001	0.000									
V	0.99**	0.94**	0.80**								
	0.000	0.000	0.001								
Cr	0.98**	0.97**	0.82**	0.97**							
	0.000	0.000	0.001	0.000							
Co	0.96**	0.99**	0.90**	0.91**	0.95**						
	0.000	0.000	0.000	0.000	0.000						
Ni	0.93**	0.99**	0.86**	0.92**	0.98**	0.99**					
	0.000	0.000	0.000	0.000	0.000	0.000					
Cu	0.87**	0.97**	0.88**	0.87**	0.92**	0.95**	0.96**				
	0.000	0.000	0.000	0.000	0.000	0.000	0.000				
Zn	0.90**	0.99**	0.87**	0.90**	0.94**	0.99**	0.98**	0.98**			
	0.000	0.000	0.000	0.000	0.000	0.000	0.000	0.000			
Pb	0.90**	0.99**	0.87**	0.90**	0.95**	0.99**	0.99**	0.98**	0.99**		
	0.000	0.000	0.000	0.000	0.000	0.000	0.000	0.000	0.000		
Cd	0.116	0.133	0.339	0.172	0.052	0.147	0.048	0.052	0.134	0.088	
	0.705	0.665	0.257	0.574	0.866	0.631	0.876	0.867	0.662	0.775	
As	0.93**	0.98**	0.86**	0.92**	0.97**	0.96**	0.97**	0.96**	0.96**	0.98**	0.050
	0.000	0.000	0.000	0.000	0.000	0.000	0.000	0.000	0.000	0.000	0.872

** $p \leq 0.01$

correlations between the elements, except Cd, suggesting their common sources, mutual dependence, and identical behavior during transport. The absence of correlation between Cd and other elements suggested that the concentration of these elements was not controlled by a single factor, but a combination of geochemical support phases and their mixed associations (Shang et al. 2015). The high positive correlation of Fe with the elements indicated that these elements are contributed to the environment by the Fe oxides (Veerasingam et al. 2012), and significant higher correlations obtained between Al and the elements indicated that these elements were mainly derived from terrigenous materials along with the anthropogenic origin. Highly significant positive correlations were found between Al and As ($r = 0.93$; $p \leq 0.01$), indicating that As was probably affected by siliciclastic and anthropogenic inputs (Xu et al. 2014). The significant positive correlation of finer particles (silt + clay) with Al ($r = 0.86$; $p \leq 0.01$), Fe ($r = 0.95$; $p \leq 0.01$), Mn ($r = 0.92$; $p \leq 0.01$), V ($r = 0.88$; $p \leq 0.01$), Cr ($r = 0.89$; $p \leq 0.01$), Co ($r = 0.94$; $p \leq 0.01$), Ni ($r = 0.92$; $p \leq 0.01$), Cu ($r = 0.94$; $p \leq 0.01$), Zn ($r = 0.94$; $p \leq 0.01$), Pb ($r = 0.93$; $p \leq 0.01$), and As ($r = 0.91$; $p \leq 0.01$) reveals that these elements in the sediments mainly exist in mud particles ($<63 \mu\text{m}$) due to the high specific surface area of the fine particles which results in greater surface adsorption and ionic attraction between the elements.

3.3.5.2 Hierarchical Cluster Analysis (HCA)

Hierarchical cluster analysis (HCA) was carried out to study the behavioral pattern of the elements of the 13 sampling sites (depicted in Fig. 3.4a) which formed two distinct clusters. Cluster 1 comprising solitary sampling site Gangasagar (S_{13}), a high-energy regime located at the confluence of Hooghly River and Bay of Bengal, could be considered as the most pristine site. The relatively low concentration of all the elements might be attributed to the sandy sediment texture of Gangasagar that prevents sedimentation of fine-grained sediment. The rest of the sampling sites, on the other hand, form the second cluster, with subgrouping formed between Budge Budge (S_2)–Diamond Harbour (S_4), Chandannagar (S_1)–Nurpur (S_3), and Herobhanga (S_{10})–Netidhopani (S_{11}) depending on their differential exposures to differential levels of anthropogenic stresses, distance from the sea, influence of tidal activity, and their location either to the Hooghly River or Sundarban mangrove wetland.

Cluster analysis was performed to identify relationships among metals and their possible sources (Chung et al. 2011; Thuong et al. 2013). Four clusters were observed (Fig. 3.4b) for the elements in 0–10-cm sediment. The first cluster was formed by Al and Fe and was highly correlated with each other ($r = 0.94$; Table 3.3). Though both the major elements are found to be abundant in the Earth's crust (Turekian and Wedepohl 1961), they were derived from both anthropogenic and lithogenic sources in this environment. The second cluster formed by V and Cr indicated that these two elements were mainly derived from anthropogenic sources (e.g., inorganic fertilizer application, glass production, leather manufacture, etc.). The third and fourth clusters of Ni and Cu and Co and Pb, respectively, were mainly derived from human-induced pollutions (e.g., discharge of domestic and industrial

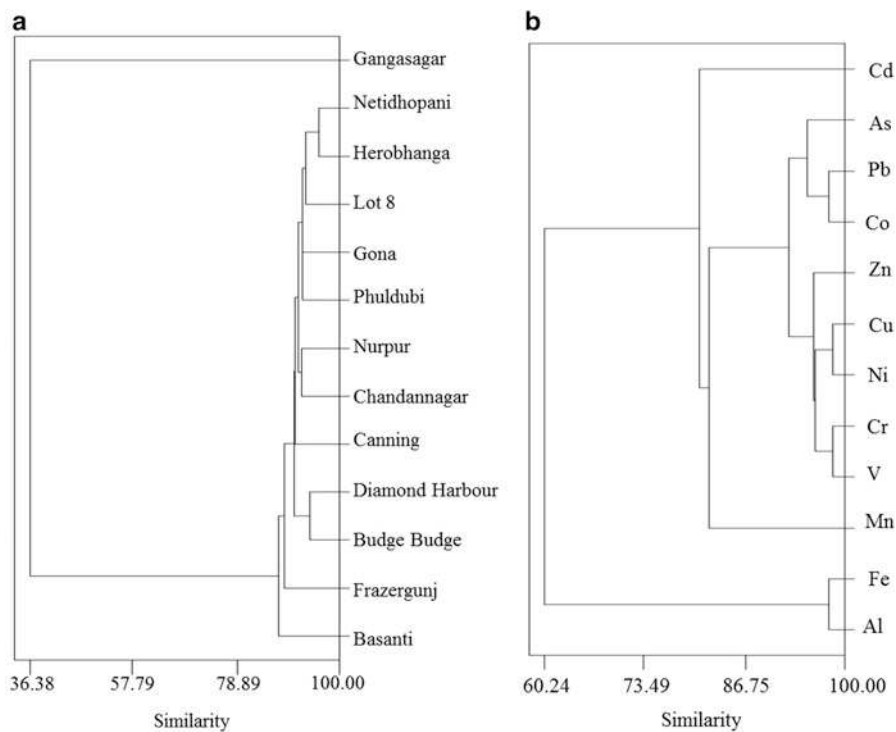

Fig. 3.4 Dendrogram showing the relationship between (a) 13 sampling sites and (b) 12 trace elements

effluents as well as release of agricultural input into the river, vehicle fumes, etc.). The above results were also confirmed by correlation matrix (Table 3.3).

3.3.5.3 Principal Component Analysis (PCA)

Principal component analysis extracted two common factors explaining 84.5% of the total data variability. According to Cattell and Jaspers (1967), PCs with eigenvalue >1 were retained. Most of the elements were grouped together near the right side of the X-axis (Fig. 3.5), which contributed high positive loadings to factor 1 (F1). The first factor contributed 71.44% of total variance, showing strong positive loadings on Fe (0.99), Mn (0.81), V (0.86), Cr (0.92), Co (0.98), Ni (0.97), Cu (0.94), Zn (0.97), Pb (0.97), As (0.97), and mud (0.89). The elements which are grouped with Fe and Al indicate that they mainly originate from natural rock weathering processes, and the high positive loading of mud can be termed as “mud factor” which indicate that they were concentrated in the finer particles. This result coincides with the conclusion of correlation analysis revealing that these elements might have a common source of origin. The solitary element Cd is

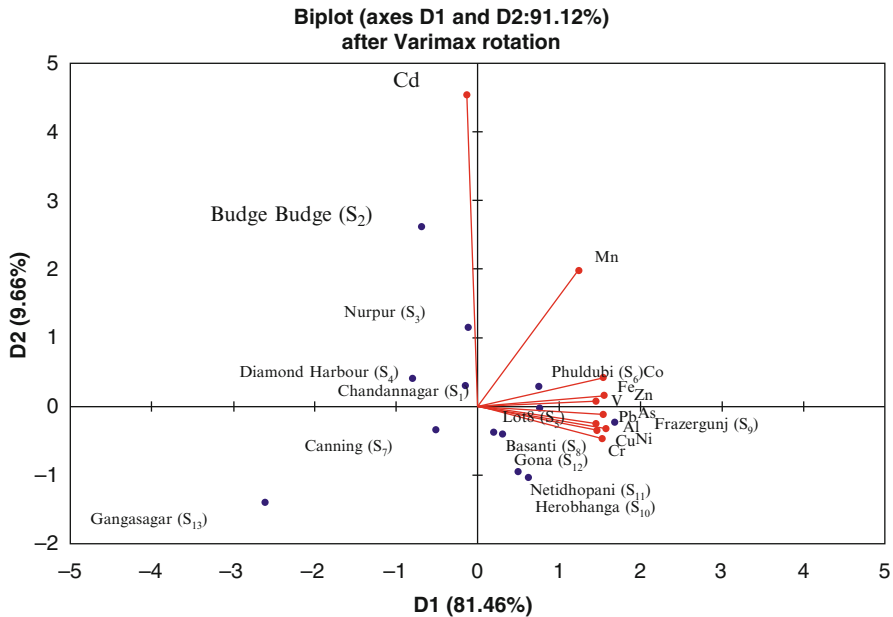

Fig. 3.5 Plot of principal component analysis (PCA) of sediments for elements and sampling sites

scattered in the plot (Fig. 3.5), suggesting its anthropogenic source in this environment.

The second factor (F2), explaining 13.13% of total variance, contained a negative high loading on Cd (0.95) with $C_{org}\%$. The use of phosphate fertilizers is an important source of Cd in this estuarine environment. Other sources of Cd may include inorganic fertilizers (e.g., nitrogen or potash), atmospheric deposition, or anthropic wastes such as sewage sludge, wastewater, or waste materials (Thuong et al. 2013).

3.4 Conclusion

The baseline study documented the sources, distribution, and ecological risk of surface sediments in a tropical meso-macrotidal estuarine environment. This is evident that trace metal contamination is affected by a wide range of complex and cohesive mechanisms/processes such as adsorption/desorption, precipitation, coagulation, and flocculation. The concentrations of the elements showed anomalous distribution in the sediments with majority of the elements showing maximum concentration at Frazergunj, western part of Sundarban. The results of sediment quality indicators (I_{geo} , EF, and E^l_r) revealed significant pollution by Cd, and it possesses low environmental risk at the sampling site Budge Budge (S₂), Hooghly estuary. The data provided in this study is expected to serve as a useful guide for

sound management of this river basin where intensive and diverse anthropogenic activities have been found to be culpable for trace metal contamination. There is always a change in the positions of the repository and source of pollutants in such dynamic coastal environment. The concentrations of trace elements were controlled by discharge points from the catchment area, marine boat activities, bay morphology, and sediment types (sand, silt, and clay) as endorsed by Alyazichi et al. (2017) while studying the trace element pollution in surface sediments from the Georges River, Southern Sydney, Australia. Reliable continuous environmental monitoring, the determination of local background through sediment cores, and further ecotoxicological studies are essential for identifying and preventing pollution in this stressed estuarine environment.

References

- Ahmad S, Siddiqui EN, Khalid S (1996) Studies on certain physico chemical properties of soil of two fresh water ponds of Darbhanga. *Environ Pollut* 31:31–39
- Alyazichi YM, Jones BG, McLean E, Pease J, Brown H (2017) Geochemical Assessment of trace element pollution in surface sediments from the Georges River, Southern Sydney, Australia. *Arch Environ Contam Toxicol* 72(2):247–259
- Antizar-Ladislao B, Mondal P, Mitra S, Sarkar SK (2015) Assessment of trace metal contamination level and toxicity in sediments from coastal regions of West Bengal, eastern part of India. *Mar Pollut Bull* 101:886–894
- Banerjee K, Senthikumar B, Purvaja R, Ramesh R (2012) Sedimentation and trace metal distribution in selected locations of Sundarbans mangroves and Hooghly estuary, Northeast coast of India. *Environ Geochem Health* 34(1):27–42
- Bhuiyan MAH, Parvez L, Islam MA, Dampare SB, Suzuki S (2010) Heavy metal pollution of coal mine-affected agricultural soils in the northern part of Bangladesh. *J Hazard Mater* 173:384–392
- Cattell RB, Jaspers J (1967) A general plasmode (no. 30-10-5-2) for factor analytic exercises and research. *Multivar Behav Res Monogr* 67:1–212
- Chai M, Shen X, Li R, Qiu G (2015) The risk assessment of heavy metals in Futian mangrove forest sediment in Shenzhen Bay (South China) based on SEM–AVS analysis. *Mar Pollut Bull* 97:431–439
- Chakraborty P (2017) Mercury exposure and Alzheimer’s disease in India – an imminent threat? *Science of the total environment*. [dx.doi.org/10.1016/j.scitotenv.2017.02.168](https://doi.org/10.1016/j.scitotenv.2017.02.168)
- Chatterjee M, Silva Filho EV, Sarkar SK, Sella SM, Bhattacharya A, Satpathy KK, Prasad MVR, Chakraborty S, Bhattacharya BD (2007) Distribution and possible source of trace elements in the sediment cores of a tropical macrotidal estuary and their ecotoxicological significance. *Environ Int* 33:346–356
- Christophoridis C, Dedepsidis D, Fytianos K (2009) Occurrence and distribution of selected heavy metals in the surface sediments of Thermaikos Gulf, N. Greece. Assessment using pollution indicators. *J Hazard Mater* 168:1082–1091
- Chung CY, Chen JJ, Lee CG, Chiu CY, Lai WL, Liao SW (2011) Integrated estuary management for diffused sediment pollution in Dapeng Bay and neighbouring rivers (Taiwan). *Environ Monit Assess* 173:499–517
- Clabby C (2010) Does peak phosphorous loom? *Am Sci* 98(4):291
- Corsolini S, Sarkar SK, Guerranti C, Bhattacharya BD, Rakshit D, Jonathan MP, Godhantaraman N (2012) Perfluorinated compounds in surficial sediments of the Ganges River and adjacent Sundarban mangrove wetland, India. *Mar Pollut Bull* 64:2829–2833

- Daskalakis KD, O'Connor TP (1995) Normalization and elemental sediment contamination in the coastal United States. *Environ Sci Technol* 29:470–477
- Dhanakumar S, Rutharvel Murthy K, Solaraj G, Mohanraj R (2013) Heavy-metal fractionation in surface sediments of the Cauvery River Estuarine Region, Southeastern Coast of India. *Arch Environ Contam Toxicol* 65:14–23
- Diagomanolin V, Farhang M, Ghazi-Khansari M, Jafarzadeh N (2004) Heavy metals (Ni, Cr, Cu) in the Karoon waterway river, Iran. *Toxicol Lett* 151:63–68
- Ding Z, Liu J, Li L, Lin H, Wu H, Hu Z (2009) Distribution and speciation of mercury in surficial sediments from main mangrove wetlands in China. *Mar Pollut Bull* 58:1319–1325
- Duran R, Ranchou PM, Menuet V, Monperrus M, Bareille G, Goñi M, Salvado J, Amouroux D, Guyoneaud R, Donard O, Caumette P (2008) Mercury methylation by a microbial community from sediments of the Adour Estuary (Bay of Biscay, France). *Environ Pollut* 156:951–958
- Folk RL, Ward WC (1957) Brazos River bar [Texas]; a study in the significance of grain size parameters. *Int J Sediment Res* 27:3–26
- Forstner U, Wittmann GTW (1979) *Metal pollution in the aquatic environment*. Springer, Berlin/Heidelberg/New York
- Gao XL, Chen CTA (2012) Heavy metal pollution status in surface sediments of the coastal Bohai Bay. *Water Res* 46:1901–1911
- Gee GW, Bauder JW (1986) Particle-size analysis. In: Klute A (ed) *Methods of soil analysis*, part 1. American Society of Agronomy, Madison, pp 383–412
- Gredilla A, Stoichev T, Valleuelo SFO, Rodriguez-Iruretagoiena A, Morais P, Arana G, Diego A, Madariaga JM (2015) Spatial distribution of some trace and major elements in sediments of the Cavado estuary (Esposende, Portugal). *Mar Pollut Bull* 99:305–311. <http://dx.doi.org/10.1016/j.marpolbul.2015.07.040>
- Hakanson L (1980) An ecological risk index for aquatic pollution control: a sedimentological approach. *J Water Res* 14:975–1001
- Herut B, Sandler A (2006) Normalization methods for pollutants in marine sediments: review and recommendations for the Mediterranean. *Israel Oceanographic & Limnological Research and Geological Survey of Israel IOLR Report H*, 18
- Holder JV (2002) Chemistry and the environment. In: Clark JH, Mac Quarrie D (eds) *Handbook of green chemistry and technology*. Blackwell Science Ltd, Oxford, pp 67–78
- Hu B, Cui R, Li J, Wei H, Zhao J, Bai F, Song W, Ding X (2013) Occurrence and distribution of heavy metals in surface sediments of the Changhua River Estuary and adjacent shelf (Hainan Island). *Mar Pollut Bull* 76:400–405
- Krauss KW, Lovelock CE, McKee KL (2008) Environmental drivers in mangrove establishment and early development: a review. *Aquat Bot* 89:105–127
- Lau SS, Chu LM (2000) The significance of sediment contamination in a coastal wetland, Hong Kong, China. *Water Res* 34:379–386
- Li X, Liu L, Wang Y, Luo G, Chen X, Yang X, Gao B, He X (2012) Integrated assessment of heavy metal contamination in sediments from a coastal industrial basin, NE China. *PLoS One* 7:e39690
- Liu B, Hu K, Jiang Z, Yang J, Luo X, Liu A (2011) Distribution and enrichment of heavy metals in a sediment core from the Pearl River Estuary. *Environ Earth Sci* 62:265–275
- Liu Z, Shaoming Pan S, Sun Z, Ma R, Chen L, Wang Y, Wang S (2015) Heavy metal spatial variability and historical changes in the Yangtze River estuary and North Jiangsu tidal flat. *Mar Pollut Bull* 98:115–129
- Long ER, Morgan LG (1990) The potential for biological effects of sediment-sorbed contaminants tested in the national status and trends program. NOAA Technical Memorandum NOS OMA 52. National Oceanic and Atmospheric Administration, Seattle, Washington, DC
- Long ER, Mac Donald DD, Smith SL, Calder FD (1995) Incidence of adverse biological effects within ranges of chemical concentrations in marine and estuarine sediments. *Environ Manag* 19:81–97

- Long ER, Field LJ, Mac Donald DD (1998) Predicting toxicity in marine sediments with numerical sediment quality guidelines. *Environ Toxicol Chem* 17:714–727
- Macdonald DD, Carr RS, Calder FD, Long ER, Ingersoll CG (1996) Development and evaluation of sediment quality guidelines for Florida coastal waters. *Ecotoxicology* 5:253–278
- MacDonald DD, Ingersoll CG, Berger TA (2000) Development and evaluation of consensus-based sediment quality guidelines for freshwater ecosystems. *Arch Environ Contam Toxicol* 39:20–31
- Memet V (2011) Assessment of heavy metal contamination in sediments of the Tigris River (Turkey) using pollution indices and multivariate statistical techniques. *J Hazard Mater* 195:355–364
- Müller G (1969) Index of geo-accumulation in sediments of the Rhine River. *Geo J* 2:108–118
- Rubio B, Nombela MA, Vilas F (2000) Geochemistry of major and trace elements in sediments of the Ria de Vigo (NW Spain): an assessment of metal pollution. *Mar Pollut Bull* 40:968–980
- Ruiz F, Abad M, Bodergat AM, Carbonel P, Rodríguez-Lázaro J, Yasuhara M (2005) Marine and brackish-water ostracods as sentinels of anthropogenic impacts. *Earth Sci Rev* 72:89–111
- Sakan S, Grzetić I, Worpević D (2006) Distribution and fractionation of heavy metals in the Tisa (Tisza) River sediments. *Environ Sci Pollut Res (Online First)*:1–8
- Sarkar SK, Franciscovic-Bilinski S, Bhattacharya A, Saha M, Bilinski H (2004) Levels of elements in the surficial estuarine sediments of the Hugli river, northeast India and their environmental implications. *Environ Int* 30:1089–1098
- Sarkar SK, Binelli A, Riva C, Parolini M, Chatterjee M, Bhattacharya A, Bhattacharya BD, Jonathan MP (2012) Distribution and ecosystem risk assessment of polycyclic aromatic hydrocarbons. *Polycycl Aromat Compd* 32:1–26
- Shang Z, Ren J, Tao L, Wang X (2015) Assessment of heavy metals in surface sediments from Gansu section of Yellow River, China. *Environ Monit Assess* 187:79
- Sokal RR, Rohlf JF (1981) *Biometry: the principles and practice of statistics in biological research*, 2nd edn. W. H. Freeman and Company, San Francisco, p 859
- Spencer KL (2002) Spatial variability of metals in the inter-tidal sediments of the Medway Estuary, Kent, UK. *Mar Pollut Bull* 44:933–944
- Thuong NT, Yoneda M, Ikegami M, Takakura M (2013) Source discrimination of heavy metals in sediment and water of To Lich River in Hanoi City using multivariate statistical approaches. *Environ Monit Assess* 185:8065–8075
- Turekian KK, Wedepohl KH (1961) Distribution of the elements in some major units of the earth's crust. *Bull Geol Soc Am* 72:175–192
- Valiela I, Bowen JL, York JK (2001) Mangrove forests: one of the world's threatened major in tropical environments. *Bioscience* 10:807–815
- Veerasingam S, Venkatachalapathy R, Ramkumar T (2012) Heavy metals and ecological risk assessment in marine sediments of Chennai, India. *Carpathian J Earth Environ Sci* 7 (2):111–124
- Walkey A, Black TA (1934) An examination of the Dugtijaraff method for determining soil organic matter and proposed modification of the chronic and titration method. *Soil Sci* 37:23–38
- Wang ZH, Feng J, Jiang T, Gu YG (2013) Assessment of metal contamination in surface sediments from Zhelin Bay, the South China Sea. *Mar Pollut Bull* 76:383–388
- Wang J, Huang C, Ni Z, Jin G, Cao L, Chen H, Waxi L (2014) Analysis on distribution, speciation and source of heavy metals in superficial sediments in the Pearl River Estuary (in Chinese). *Mar Sci Bull* 33:259–267
- Watts MJ, Barlow TS, Button M, Sarkar SK, Bhattacharya B, Alam A, Gomes A (2013) Arsenic speciation in polychaetes (Annelida) and sediments from the intertidal mudflat of Sundarban mangrove wetland, India. *Environ Geochem Health* 35(1):13–25
- Xu Y, Sun Q, Yi L, Yin X, Wang A, Li Y, Chen J (2014) The source of natural and anthropogenic heavy metals in the sediments of the Minjiang River Estuary (SE China): implications for historical pollution. *Sci Total Environ* 493:729–736

- Xu F, Tian X, Yin X, Yan H, Yin F, Liu Z (2015a) Trace metals in the surface sediments of the eastern continental shelf of Hainan Island: sources and contamination. *Mar Pollut Bull* 99:276–283
- Xu G, Pei S, Liu J, Gao M, Hu G, Kon X (2015b) Surface sediment properties and heavy metal pollution assessment in the near-shore area, north Shandong Peninsula. *Mar Pollut Bull* 95:395–401
- Xu F, Qiu L, Cao Y, Huang J, Liu Z, Tian X, Li A, Yin X (2016a) Trace metals in the surface sediments of the intertidal Jiaozhou Bay, China: sources and contamination assessment. *Mar Pollut Bull* 104:371–378
- Xu F, Tian X, Yin F, Zhao Y, Yin X (2016b) Heavy metals in the surface sediments of the northern portion of the South China Sea shelf: distribution, contamination, and sources. *Environ Sci Pollut Res* 23:8940–8950
- Yang Y, Chen F, Zhang L, Liu J, Wu S, Kang M (2012) Comprehensive assessment of heavy metal contamination in sediment of the Pearl River Estuary and adjacent shelf. *Mar Pollut Bull* 64:1947–1955
- Zhang J, Gao X (2015) Heavy metals in surface sediments of the intertidal Laizhou Bay, Bohai Sea, China: distributions, sources and contamination assessment. *Mar Pollut Bull* 98:320–327
- Zhang J, Liu CL (2002) Riverine composition and estuarine geochemistry of particulate metals in China—weathering features, anthropogenic impact and chemical fluxes. *Estuar Coast Shelf Sci* 54:1051–1070

Total and Acid-Leachable Trace Metals in Surface Sediment of Sundarban Wetland and Adjacent Hooghly River Estuary

Abstract

The chapter examines a detailed account of the geochemical assessment of ten trace metals (TMs) in total and acid-leachable (ALTM) fractions of the surface sediments (grain size $< 63 \mu\text{m}$; top 0–10 cm) from Sundarban coastal regions and adjacent Hooghly River Estuary (HRE), India. Total TM concentration exhibited a wide range of variations in the following descending order (mean values expressed in mg kg^{-1} dry weight): Fe (32343.40 ± 6726.21) $>$ Mn (549.51 ± 121.85) $>$ Zn (87.63 ± 15.86) $>$ Cr (64.83 ± 12.81) $>$ Ni (55.67 ± 8.66) $>$ Cu (49.13 ± 20.24) $>$ Co (41.48 ± 9.03) $>$ As (36.65 ± 11.74) $>$ Pb (24.78 ± 2.64) $>$ Cd (4.63 ± 1.65). An overall similar trend was also discernible for leachable fractions, except two hazardous trace metals, Pb and As. The mean bioavailability for the TMs revealed that Pb was the most mobile (27.10%), followed by Cu, Zn, and As (13–17%) and Cd, Ni, Co, and Cr (4–7%), mainly concerned with multitude of human activities (industrial effluents, discharge of sewage, agricultural runoff, etc.). Maximum concentration of majority of the TMs was evident at the lower stretch of the estuary. The geoaccumulation index (I_{geo}) and contamination factor (CF) values affirm the intensity of severe pollution by Cd and As. The ecological risk associated with the TMs in sediment was considered to be occasionally observed for As, Cd, Cu, and Ni (effects range low (ERL)–effects range medium (ERM)) and frequently observed for Ni (greater than ERM) based on assessment using consensus-based sediment quality guidelines (SQGs). A similar pattern of correlations was observed for TMs and ALTMs as evident from Pearson correlation matrix, whereas ALTMs exhibited significant association with silt. The study provides a useful tool for sustainable management in this productive estuarine complex.

Keywords

Sediment • Acid-leachable trace metals (ALTMs) • Bioavailability • Ecological risk assessment • Hooghly River Estuary (HRE) • Indian Sundarban wetland

4.1 Introduction

In sediments, heavy metals are in existence in a number of chemical forms and generally exhibit different physical and chemical behaviors in terms of chemical interaction, mobility, biological availability, and potential toxicity (Sundaray et al. 2011; Ma et al. 2016). Due to urbanization and rapid growth of industrialization, heavy metals are released exponentially in the estuarine environment. Anthropogenic activity has dramatically increased the amount of potentially toxic compounds in many ecosystems, threatening human health and causing a decline in species diversity (UNEP/MAP 2012; Belabed et al. 2013; Zaaboub et al. 2015). Sediments are the main repository and source of heavy metals in the aquatic environment and play an important role in the transport and storage of potentially hazardous metals (Nasr et al. 2015). The study of sediment plays an important role as they have a long residence time. Marine sediments act as a sink for heavy metals, concentrating them and acting as a filter through precipitation and sequestration (Satpathy et al. 2012). In addition to acting as heavy metal sinks, a number of simultaneous processes, including resuspension and bioturbation, occur in marine and estuarine environments which can make them available for uptake into the biosphere (Gonzalez-Fernandez et al. 2011).

In general, the determination of the total concentration of metals in sediments is not considered a good indicator to be able to predict the capacity for mobilization or determine the toxic effects of these elements (Nasr et al. 2015; Duodu et al. 2017).

With respect to contaminated sediment, study of bioavailability is very important in predicting the potential environmental and ecotoxicological impacts. It may be defined as the maximum amount of a contaminant which is available, or solubilized, in the gastrointestinal environment of an organism (Tumer and Olsen 2000). Thus, the leaching of metals provides database of the bioavailable metals in any aquatic environment which are often readily available to organisms affecting them directly (Jonathan et al. 2010). The binding behavior of metals in sediments is crucial for assessing both the source and potential risk they pose to aquatic species. The binding behavior or mobility is affected with changes in environmental conditions such as pH, redox potential, sorbent nature, and presence and concentration of organic and inorganic ligands, including humic and fulvic acids, root exudates, and nutrients (Violante et al. 2010). These factors are all related for the metals to be transferred or mobilized between sediment and overlying water which are in turn important for evaluating the potential impact on aquatic organisms such as mobility as well as the bioavailability of the metals in sediment (Peijnenburg et al. 2007).

Reporting the actual metal concentrations within the leached fraction alone seems a more logical way to eliminate the need for mathematical corrections or physical separations of the final output. This fraction depends on the association of the elements with particles, the binding strength and the water properties such as pH, and the redox potential, salinity, dissolved metal species which are in touch with the solid phase (Filgueiras 2004; Jonathan et al. 2010).

The aim of the present study is (i) to assess the TM contamination level in sediments and subsequently to measure their bioavailability to predict potential toxicity of sediments in a tropical estuarine environment and (ii) to employ a range of sediment quality indices to give insights into the risk posed by the contaminated sediment. In addition, the sources of metals are quantified to give potential information for the formulation of effective mitigation and management strategies.

4.2 Materials and Methods

4.2.1 Study Area and Sampling Sites

Hooghly River Estuary (HRE), the first deltaic offshoot of the Ganges River, is an urban, industrialized, mixohaline-positive, well-mixed estuary with shallow depth (average ~ 6 m) and drains a catchment area of 6×10^4 km². The estuary gets semidiurnal tides with maximum range of 5.5 m at spring and minimum 1.8 m at neap. This globally significant estuary provides perpetual supply of water to the plains of West Bengal for multipurpose activities (such as irrigation, navigation of small ships and fishing boats, human and industry consumption together with fishing), thus supporting the lives of millions of people. A significant ecological change is pronounced in this area due to huge discharges of untreated or semi-treated domestic and municipal sewage as well as effluents from multifarious industries carried by rivers as well as contaminated mud disposal from harbor dredging. Recent studies reported that the sedimentation accumulation rate in HRE and Indian Sundarban is ~ 3.0 – 4.8 mm year⁻¹ (Banerjee et al. 2012). This high sedimentation rate can cause a change in the geochemical characteristics of the surface sediments on an annual scale as endorsed by other workers (Liu et al. 2011).

Surface sediment samples (top 0–10 cm) were collected along the Hooghly River Estuary [Tribeni (S₁), Chandannagar (S₂), Barrackpore (S₃), Budge Budge (S₄), Nurpur (S₅), Diamond Harbour (S₆), Lot 8 (S₇), and Gangasagar (S₈)] (as shown in Fig. 2.1). The studied sampling sites are characteristically different from each other having different geomorphic and tidal environments, different wave energy fluxes, exposure to contaminants, and distances from the sea (Bay of Bengal). The variations of physical processes such as suspension–resuspension, flocculation–deflocculation, and adsorption–desorption of mud clasts result in a spatial variation of the sediment behavior in local and regional scales. The sampling sites also differ from each other and have diverse human interference with a variable degree of exposure to trace metal contamination. The brief description of the sampling sites selected for this study is reported in Table 4.1.

4.2.2 Collection and Preservation of Sediment Sample

The surface sediments were collected using a PVC tube during ebb tide from intertidal areas of eight sampling sites along the Hooghly River Estuary (HRE).

Table 4.1 Description of sampling sites along the Hooghly River Estuary (S_1 to S_8) along with respective sources of pollution from point and nonpoint sources

Sampling sites	Coordinates	Nature of ecological stress
Tribeni (S_1)	22°59'25" N– 88°24'12"E	Paper factory, tire and rayon industry, jute mills, thermal power station, crematorium, untreated domestic discharge, ferry service, brick kiln
Chandannagar (S_2)	22°15'35" N– 88°22'17"E	Jute mills, oil mills, tannery, brick kiln, ferry service, idol immersion
Barrackpore (S_3)	22°45'51" N– 88°20'40"E	Thermal power plants, rifle factory, dry cell and cable industries, leather industry, riverine traffic, use of antifouling paints and use of burnt oil in mechanized boats, use of herbicides and pesticides in near-shore agricultural fields
Budge Budge (S_4)	22°33'58" N– 88°11'16"E	Crematorium, jute mills, cable industry, oil storage plant, thermal power plants
Nurpur (S_5)	22°12'40" N– 88°04'16"E	Paper factory and coal-based thermal power plant
Diamond Harbour (S_6)	22°11'13"N– 88°11' 24" E	Leather industry, tourism activities, ferry service, fish landing site, and mud disposal from harbor dredging
Lot 8 (S_7)	22°52'29"N– 88°10'09"E	Boating, agricultural runoff and domestic sewage. Frequent dredging, fishing activity
Gangasagar (S_8)	21°38'24" N– 88°04'46"E	Boating, tourist activities, dredging, fishing, and agricultural, domestic, and aquaculture practices

The samples are sealed in acid-rinsed polyethylene bags with no head space and temporarily kept in a cool box with ice packs at 4 °C to prevent changes in chemical composition among different phases. The sediments were stored at –20 °C until further analysis. Samplings were at least triplicated at each location to ensure the representativeness of the samples. During sample collection, a handheld global positioning system (GPS) was used to locate the sampling sites.

4.2.3 Physicochemical Analysis of Sediments

The sediment samples were oven-dried at 40 °C to a constant weight. The dried sediments are ground gently with an agate mortar and pestle; a portion of the dried sample was sieved through a 63- μ m nylon mesh for homogenization and stored in sealed plastic bags until further analyses. A fraction of fresh unsieved sample was separated for determining the sediment quality parameters like organic carbon and grain-size fraction. The organic carbon (C_{org} %) content of the sediments was determined with a rapid titration method (Walkey and Black 1934).

The grain-size analyses were done by separating the sand fraction by wet sieving using a 63- μ m mesh sieve. The silt (4–63 μ m) and clay (<4 μ m) fractions were determined using the pipette method (Gee and Bauder 1986) in which a sample suspension is prepared using sodium hexametaphosphate as the dispersing agent, and aliquots are pipetted at different time intervals and from different depths and

dried and weighed for mass determination, and statistical computation of textural parameters was done by using formulae of Folk and Ward (1957). Textural classification of the sediment samples was based on the relative percentages of clay ($<4 \mu\text{m}$), silt ($4\text{--}63 \mu\text{m}$), and sand ($>63 \mu\text{m}$).

4.2.4 Analytical Procedure

4.2.4.1 Total Trace Metals

Due to the high specific surface of the smaller particles and strong association with metals (Idris et al. 2007), the analysis of TM content was conducted for fine grain-size fractions ($<63 \mu\text{m}$) to describe the characteristics of sediment samples. Dry powdered samples (0.5 g) were mixed with 9 ml of conc. HNO_3 and 3 ml of hydrofluoric acid (HF) for 15 minutes in a microwave system for total digestion analysis. The digestion was made for approximately 9 minutes at $180 \text{ }^\circ\text{C} \pm 4.8 \text{ }^\circ\text{C}$ and was subsequently filtered and centrifuged (EPA 3052). The reagent blanks were carried on parallel with all analyses, and the blank values were lower than 0.38% of the sample signals. Analyses of standards were done for every fifth sample to maintain the accuracy of analysis. Samples were analyzed thrice to get the accurate results on all aspects.

4.2.4.2 Autoclave Digestion of Acid-Leachable Trace Metals (ALTM)s

ALTM)s (Cu, Cd, Ni, Pb, Co, Zn, Mn, Fe, Cr, As) were determined using modified EPA 3050B microwave digestion method with 0.5 g of dry fine material (Drik et al. 1998; Jonathan et al. 2013). An acid mixture of 9:3 ratio (9 ml of conc. HNO_3 + 3 ml of conc. HCl) was added in a closed polytetrafluoroethylene (PTFE) vessel which is attached with a safety valve working at 6.8 atm (100 psi). A predigestion of solid sample (in open vessel) is done before sealing the PTFE vessels. The major component that was modified from the original procedure was the use on the amount of acid and the use of autoclave technique instead of the regular microwave digestion method. Subsequently, the aqueous solution was filtered using $0.45 \mu\text{m}$ and was made up to 50 ml for further analysis. The final solution was analyzed in ICP-OES (Varian 720ES) for Cu, Ni, Co, Zn, Mn, Fe, Cr, and As and in AASGF (Varian Spectra AA220 G7A 110) for Cd and Pb. The accuracy of the present analysis was checked with CRM-LO-B (loam soil B; Lot No. 691029), and the recoveries of those elements were equal to that of the certified values (Navarrete-Lo'pez et al. 2012) (Table 4.2). The analytical reagents used in the whole analysis were of high-purity analytical reagents. The glass vessels and the equipments used in the analyses were washed twice with dilute HCl to avoid any external contamination.

Table 4.2 Comparison of elemental recoveries through autoclave digestion method from SRM 691029 (loam soil B) using HNO₃ + HCl mixture

Methods	Reported EPA 3050A–loam soil B (reported)	Autoclave digestion 9-ml HNO ₃ + 3-ml HCl mixture (present study)
Trace Metals		
Cu	52.0 ± 4.0	52.1 ± 4
Cd	83.0 ± 5.0	76.8 ± 5
Ni	54.0 ± 4.0	52 ± 8
Pb	95.0 ± 3.0	93.8 ± 12
Co	59.0 ± 3.0	45.6 ± 4
Zn	206.0 ± 10	208 ± 22
Mn	1.47 ± 0.16	1.19 ± 0.09
Fe	22.3 ± 0.8	25.7 ± 1.85
Cr	48.0 ± 2.0	49 ± 3.2
As	45.0 ± 3.0	42.3 ± 5.2

4.2.5 Parameters of Sediment Quality Assessment

For interpretation of data, choice of background values plays an important role (Memet 2011). The best alternative is to compare concentrations between contaminated and mineralogically and texturally comparable, uncontaminated sediments (Rubio et al. 2000). Since there were no data on background concentrations for the studied coast sediment and soils of areas, the background values used in this paper were the average shale value (Turekian and Wedepohl 1961).

4.2.5.1 Geoaccumulation Index (I_{geo})

The geoaccumulation index (I_{geo}) is defined by the following equation:

$$I_{geo} = \log_2[C_n/1.5*B_n]$$

where C_n = concentration of the examined element “n” in the surface sediments and B_n = geochemical background concentration of element “n.” Factor 1.5 is the background matrix correction factor due to lithospheric effects. Müller (1981) proposed the following classes for increasing I_{geo} values: class 0 (practically uncontaminated), $I_{geo} \leq 0$; class 1 (uncontaminated to moderately contaminated), $0 < I_{geo} < 1$; class 2 (moderately contaminated), $1 < I_{geo} < 2$; class 3 (moderately to strongly contaminated), $2 < I_{geo} < 3$; class 4 (strongly contaminated), $3 < I_{geo} < 4$; class 5 (strongly to extremely contaminated), $4 < I_{geo} < 5$; and class 6 (extremely contaminated), $5 > I_{geo}$.

4.2.5.2 Contamination Factor (CF) and Pollution Load Index (PLI)

For the entire sampling site, PLI has been determined as the nth root of the product of the n CF:

$$PLI = (CF_1 \times CF_2 \times CF_3 \times \dots \times CF_n)^{1/n}$$

where:

n = number of metals.

CF = contamination factor = $C_{\text{Sample}}/C_{\text{background value}}$.

C_{Sample} = mean metal concentration in polluted sediments.

$C_{\text{Background value}}$ = mean natural background value of that metal.

CF values were interpreted as suggested by Hakanson (1980), where $CF < 1$ indicates low contamination, $1 < CF < 3$ is moderate contamination, $3 < CF < 6$ is considerable contamination, and $CF > 6$ is very high contamination.

When $PLI > 1$, it means that a pollution exists; otherwise, if $PLI < 1$, there is no metal pollution (Tomlinson et al. 1980).

4.2.5.3 Enrichment Factor (EF)

Enrichment factor (EF) is a useful tool in determining the degree of anthropogenic heavy metal pollution (Sakan et al. 2009). The EF is computed using the relationship below:

$$EF = \frac{(\text{Metal/Fe})_{\text{Sample}}}{(\text{Metal/Fe})_{\text{Background}}}$$

In this study, iron (Fe) was used as the reference element for geochemical normalization because of the following reasons: (i) Fe is associated with fine solid surfaces, (ii) its geochemistry is similar to that of many trace metals, and (iii) its natural concentration tends to be uniform (Bhuiyan et al. 2010). EF values were interpreted as suggested by Sakan et al. (2009), where $EF < 1$ indicates no enrichment, < 3 is minor enrichment, 3–5 is moderate enrichment, 5–10 is moderately severe enrichment, 10–25 is severe enrichment, 25–50 is very severe enrichment, and > 50 is extremely severe enrichment.

4.2.6 Sediment Quality Guidelines (SQGs)

Effects range low (ERL) and effects range median (ERM) are SQGs developed by Long and Morgan (1990) to categorize the range of concentrations in sediment, the effects of which are scarcely observed or predicted (below the ERL), occasionally observed (ERL–ERM), and frequently observed (above the ERM) (Long et al. 1995). The TEL/PEL SQGs are also applied to assess the degree to which the sediment-associated chemical status might adversely affect aquatic organisms and are designed to assist in the interpretation of sediment quality (Macdonald et al. 1996; Long et al. 1998; Macdonald et al. 2000). The threshold effects level (TEL) was interpreted to present chemical concentrations below which adverse biological

effects rarely occur, and the probable effects level (PEL) was intended to present chemical concentrations above which adverse biological effects frequently occur (Macdonald et al. 2000).

4.2.7 Statistical Analysis

The logarithm-transformed data [$\log_{10}(n + 1)$] were applied to eliminate the influence of different units of variance and give each determined variable an equal weight (Wang et al. 2013). The whole geochemical data set was analyzed using STATISTICA (version 8.0) to generate the factor analysis. The factor scores/analysis for TMs (two factors) and ALTMs (three factors) was generated based on the eigenvalues (>1) (e.g., Jonathan et al. 2013). Correlations were calculated using Pearson correlation coefficient (Sokal and Rohlf 1981) to analyze the relationships among all the variables for each site.

4.3 Results and Discussion

4.3.1 Sediment Geochemical Characteristics

The edaphic factors (pH, organic carbon ($C_{org}\%$), and grain-size fractions (wt. %)) in sediments of the eight sampling sites (as shown in Table 4.3). pH of the surface sediment samples ranged from slightly acidic pH of 6.89 at Barrackpore (S_3) to slightly basic pH of 7.57 at Gangasagar (S_8). The slightly acidic pH observed during the dry pre-monsoon season might be due to the decomposition of organic matter and subsequent formation of carbonic acid (Ahmad et al. 1996; Dhanakumar et al. 2013).

Values of $C_{org}\%$ showed a small range of variations, 0.27% in Tribeni (S_1) to 0.66% in Gangasagar (S_8); the observed values are comparatively low in relation to the values found in the sediments from other Indian coastal areas, such as Gulf of Mannar (Jonathan and Ram Mohan 2003), Cochin (Sunil Kumar 1996), and Muthupet mangroves (Janaki-Raman et al. 2007). The sediments of this estuarine environment are dominated by negatively charged quartz grains which are related with the poor absorbability of organics and hence account for the low values of $C_{org}\%$ (Sarkar et al. 2004). The low $C_{org}\%$ values are related with negatively charged quartz, which predominate in sediments in this estuarine environment (Sarkar et al. 2004). In addition, the constant flushing activity by the tides along with the impact of waves in intertidal zone can support the low $C_{org}\%$ in sediments.

Textural composition showed dominance of fine particles from clayey to clayey very fine which is concerned to the low fluvial discharge and a better mixing of saline and freshwater, facilitating flocculation and subsequent settling of suspended particles (Nair et al. 1982). Textural differences may be attributed to vigorous estuarine mixing, suspension–resuspension, and flocculation–deflocculation processes.

Table 4.3 Geochemical characteristics and concentrations of trace metals (expressed in mg kg^{-1} dry weight) in surface sediments along Hooghly River Estuary

Abiotic parameters	Sampling sites							
	S ₁	S ₂	S ₃	S ₄	S ₅	S ₆	S ₇	S ₈
pH	7.16	7.49	6.89	6.96	7.28	7.63	7.16	7.57
C _{org} (%)	0.27	0.60	0.63	0.36	0.45	0.42	0.42	0.66
% clay (<4 μm)	51.18	50.03	51.83	56.63	56.51	56.74	61.10	50.40
% silt (4–63 μm)	27.53	32.20	31.58	27.43	33.35	24.10	32.33	19.60
% sand (>63 μm)	21.30	17.77	16.59	15.95	10.14	19.16	6.57	30.00
Sediment texture	Clayey fine	Clayey fine	Clayey fine	Clayey fine	Clayey fine	Clayey fine	Clayey very fine	Clayey
<i>Trace metals</i>								
Cu	38.70	67.20	25.80	57.10	36.10	22.40	75.40	74.50
Cd	5.40	5.60	5.20	5.40	4.80	4.60	5.20	5.20
Ni	54.90	52.90	47.20	50.40	49.50	46.20	65.50	66.40
Pb	24.45	28.75	27.05	24.98	22.93	22.63	26.33	25.88
Co	43.30	44.50	41.50	42.70	41.80	41.20	49.60	49.70
Zn	94.90	107.90	74.40	91.20	69.30	60.10	97.30	98.60
Mn	483.60	467.20	450.40	517.10	542.10	479.90	576.90	578.40
Fe	30257.50	30837.30	27313.50	28316.10	28747.10	25527.30	36556.80	36335.00
Cr	61.30	58.50	54.40	58.20	54.40	54.40	76.20	76.10
As	53.98	41.99	41.99	39.99	37.99	41.99	24.97	33.95

4.3.2 Total and Acid-Leachable Trace Metal (ALTM) Concentration

The distribution and concentrations of total TMs and acid-leachable trace metals (ALTM) in the intertidal surface sediments from HRE are shown in Tables 4.3 and 4.4, respectively. The inconsistent, anomalous trend of distribution and spatial heterogeneity of the ten TMs were very much pronounced which might be attributed to (i) location of the eight sampling sites along HRE experiencing different tidal and geomorphic settings and differences in hydrodynamic regimes, (ii) natural variability including intricate physical and chemical processes, (iii) variations in sediment particle size (clayey very fine to clayey), and (iv) nonhomogeneous inputs from point and nonpoint sources of the TMs.

Copper concentration ranged from 22.40 mg kg⁻¹ to 75.40 mg kg⁻¹ and in the ALTM fraction from 1.83 mg kg⁻¹ to 19.50 mg kg⁻¹, representing greater than 15% of bioavailable Cu at all the sampling sites (except at Gangasagar (S₈)). The potential anthropogenic contributors of Cu are the use of antifouling paints used locally in boats in harbor and tourist areas (Marmolejo-Rodriguez et al. 2007), industrial effluent discharge, and input of untreated domestic sewage. The concentration of total Cd varied from 4.60 mg kg⁻¹ at Diamond Harbour (S₆) to 5.60 mg kg⁻¹ at Chandannagar (S₂), with a mean concentration of 4.63 ± 1.65 mg kg⁻¹. A consistent and uniform trend of Cd concentration in sediment was remarkably present in all the sampling sites which might be attributed to urban sewage, fertilizers from the nearby agricultural field and traffic load, paint industries, ship waste, and anticorrosive paints applied on the boats and ships (Nobi et al. 2010). In the acid-leachable phase, Cd showed the lowest percentage (avg. 4.32%) with maximum content of 0.30 mg kg⁻¹ at Lot 8 (S₇). This toxic metal is widely spread by human activity, volcanic activities, and erosion and in the production of nickel-cadmium batteries or in welding.

Nickel concentration varied from 46.20 mg kg⁻¹ to 66.40 mg kg⁻¹ with an average of 55.67 ± 8.66 mg kg⁻¹. The elevated Ni values at the surface layer are due to the effective trapping of Ni in aerobic conditions in the oxic-suboxic conditions in the study area (Sawlan and Murray 1983). The concentration of Co ranging from 41.20 mg kg⁻¹ to 49.70 mg kg⁻¹ exhibited a homogeneous distribution pattern in the sediment. The percentage of Ni and Co in the acid-leachable fraction varied from 1.54% to 9.07% of the TM concentration.

Total Pb concentrations ranged between 22.63 mg kg⁻¹ and 28.75 mg kg⁻¹, while its leachable counterpart ranged from 5.30 to 9.40 mg kg⁻¹, representing 20.58% to 33.27% of the total Pb. The prevalent high concentration might be attributed to river-borne sources (Förstner 1983) as well as intensive human activities (Alagarsamy 2006) including agriculture in the drainage basin (Monbet 2006) and auto-exhaust emission together with atmospheric deposition (Adriano 1986). The average Pb levels in Indian River sediments are about 14 mg kg⁻¹ (Decov et al. 1999). In this study, all the sampling sites have Pb concentrations greater than 14 mg kg⁻¹. The maximum and minimum concentration of Zn varied from 60.10 mg kg⁻¹ to 107.90 mg kg⁻¹. In the estuary, the labile Zn contents are relatively homogeneous with 12.27–23.45% of the total. Although Zn is mobile in

Table 4.4 Acid-leachable trace metal concentration and percentage of bioavailable fraction in surface sediments

Sampling sites	Cu		Cd		Ni		Pb		Co		Zn		Mn		Fe		Cr		As	
	mg kg ⁻¹	%	mg kg ⁻¹	%	mg kg ⁻¹	%	mg kg ⁻¹	%	mg kg ⁻¹	%	mg kg ⁻¹	%	mg kg ⁻¹	%	mg kg ⁻¹	%	mg kg ⁻¹	%	mg kg ⁻¹	%
S ₁	6.38	16.47	0.20	3.70	4.40	8.01	5.88	24.03	3.30	7.62	13.78	14.52	73.23	15.14	4083.78	13.50	4.53	7.38	6.61	12.25
S ₂	10.83	16.11	0.23	4.02	4.80	9.07	9.40	32.70	3.33	7.47	15.73	14.57	70.98	15.19	4284.73	13.89	4.95	8.46	4.39	10.45
S ₃	5.20	20.16	0.28	5.29	3.85	8.16	9.00	33.27	2.88	6.93	14.33	19.25	77.13	17.12	4116.78	15.07	5.13	9.42	8.52	20.30
S ₄	8.85	15.50	0.23	4.17	4.00	7.94	6.70	26.83	2.68	6.26	14.48	15.87	79.30	15.34	3902.33	13.78	4.18	7.17	4.35	10.87
S ₅	9.15	25.35	0.15	3.13	3.05	6.16	5.30	23.12	2.45	5.86	16.25	23.45	74.88	13.81	3455.98	12.02	3.13	5.74	6.08	16.01
S ₆	3.73	16.63	0.18	3.80	3.50	7.58	5.85	25.86	2.60	6.31	12.23	20.34	78.68	16.39	3891.83	15.25	3.33	6.11	8.33	19.85
S ₇	19.50	25.86	0.30	5.77	5.35	8.17	8.00	30.39	3.13	6.30	17.60	18.09	85.35	14.79	4890.15	13.38	3.48	4.56	2.96	11.87
S ₈	1.83	2.45	0.08	1.44	1.03	1.54	5.33	20.58	1.48	2.97	12.10	12.27	31.08	5.37	1923.13	5.29	2.40	3.15	3.13	9.23

most sediment, clay fractions are capable of holding Zn quite strongly, especially at neutral and alkaline pH regimes (Kabata-Pendias 2010).

Iron and Mn have fairly close distribution patterns of enrichment in sediment (Fe, 25527.30–36556.80 mg kg⁻¹; Mn, 450.40–578.40 mg kg⁻¹) at all the sampling sites which might be due to the early diagenetic processes as well as the strong association to the geochemical matrix between the two trace metals (Jonathan et al. 2010). In the acid-leachable phase, Fe and Mn varied from 1923.13–4890.15 mg kg⁻¹ to 31.08–85.35 mg kg⁻¹, respectively.

A variety of anthropogenic activities contributes to the release of chromium in the sediments. For TM and ALTMs, Cr concentration varied from 54.40 mg kg⁻¹ to 76.20 mg kg⁻¹ and from 2.40 mg kg⁻¹ to 5.13 mg kg⁻¹, respectively. This transitional metal is mainly derived from paint, coating, and tannery industries in this estuarine region as endorsed by Alam et al. 2010. Arsenic is a naturally occurring trace metal widely distributed in the natural environment (Chen et al. 2010). Arsenic concentration in the sediments ranged from 24.97 mg kg⁻¹ at Lot 8 (S₇) to 53.98 mg kg⁻¹ at Tribeni (S₁). In the acid-leachable phase, its concentration varied from 2.96 to 8.52 mg kg⁻¹ representing 9.23% to 20.30% of the total concentration. The higher concentration of As in this estuarine region might be attributed to application of fertilizers and insecticides in the nearby agricultural fields, intense exploitation of groundwater, as well as burning of coal for domestic purposes. The contaminant is also derived from urbanization of the catchment area and the associate sewage and domestic water discharge (Morelli and Gasparon 2014).

A unique consistent trend of maximum concentration of majority of TMs (Cu, Ni, Co, Mn, Fe, and Cr) has been encountered at the lower stretch of the estuary. The prevalent high concentrations are very much concerned to the severe ongoing human activities including dredging, fishing, transport, and erosion. For similar reasons, sharp synchronous elevated levels of majority of the ALTMs (Cu, Cd, Ni, Zn, Mn, and Fe) were also observed at the same sampling site.

4.3.3 Bioavailability of Trace Metal Concentration

The percentage of bioavailable fraction in surface sediments of Hooghly River Estuary is reported in Table 4.4. Total metal content does not indicate the potential availability of sediment-bound metals to aquatic life. Thus, the study of bioavailability is important in predicting environmental and ecotoxicological impacts. Potential metal bioavailability was calculated as the percentage of the exchangeable fraction relative to the total metal concentration in the sample providing a method to assess the risk posed to the benthic fauna by heavy metals (Tessier et al. 1979).

In the estuary, Pb showed a strong affinity with the acid-leachable fraction (bioavailability percentages ranging from 27 to 55%) suggesting its easier mobility and bioavailability in this aquatic medium, whereas the bioavailability percentages of the other ALTMs were below 20%. Among the studied ALTMs, Cr was in the lower percentage in the acid-leachable fraction (3–9%), indicating that this toxic

metal cannot be remobilized into the aquatic medium under (bio)geochemical conditions normally occurring in nature (El-Bilali et al. 2002). Exchangeable Fe varied between 5% and 15%, with a high value of 15.07% and 15.25% at sampling sites Barrackpore (S₃) and Diamond Harbour (S₆), respectively. The bioavailability of Fe and Mn was monitored because of their tendency to form iron oxides and hydroxides and thus act as potential scavengers for other heavy metals (Siegel 2002). These bioavailable fractions can be mobilized under oxidant conditions close to the shore region or open ocean, where they can be available to water column during the seasonal/annual rainfall events. When compared to the total metal concentrations, potential metal bioavailability decreased in the following order: Pb > Cu > Zn > Mn > As > Fe > Ni > Cr > Co > Cd.

4.3.4 Evaluation of Sediment Contamination

4.3.4.1 Geoaccumulation Index (I_{geo})

All sediments fall in class 0 for Ni, Pb, Zn, Mn, Fe, and Cr, indicating that the sampling sites were not contaminated by these studied TMs (as shown in Fig. 4.1). For all the sampling sites, Co and Cd fall in class 2 and class 4, respectively, showing moderate to strong contamination by these metals. For As, three sampling sites fall in class 1, and the rest of the sampling sites fall in class 2 indicating moderate contamination of the studied area. In this area, As contamination was already observed in previous studies, and it is probably due to groundwater contamination (Dowling et al. 2002). This contamination can have natural origin, such as coal seams in Rajmahal Basin and arsenic mineral rocks in the upper reaches of the Ganges River system. The highly reducing nature of groundwater would reduce As, causing the possible desorption of As (Acharyya et al. 2000).

4.3.4.2 Contamination Factor (CF) and Pollution Load Index (PLI)

The CF values for Cd at all the sampling sites were >6 in sediments indicating a “very high contamination” by these trace metals (Fig. 4.2). The CF values for As varied from 1.92 to 4.15 showing “considerable contamination, while the CF values for Co indicated a moderate contamination.”

The pollution load index ranged from 1.51 at Barrackpore (S₃) to 1.94 at Lot 8 (S₇) with a mean of 1.74 indicating that the studied region was moderately polluted with the studied TMs (Fig. 4.2).

4.3.4.3 Enrichment Factor (EF)

In order to get information about the potential sources of TMs in the intertidal sediments of HRE, the EF of each element at each sampling site was calculated. The results showed that the mean EF values of the studied TMs followed the sequence Cd (27.02) > As (4.85) > Co (3.63) > Pb (1.98) > Cu (1.66) > Zn (1.41) > Ni (1.23) > Cr (1.06) > Mn (0.94). The EF values of Cu, Ni, Pb, Zn, Mn, and Cr at all the sampling sites were less than 3 (EF < 3) indicating minor enrichment of the sediments by these TMs. Moderate enrichments (3 < EF < 5)

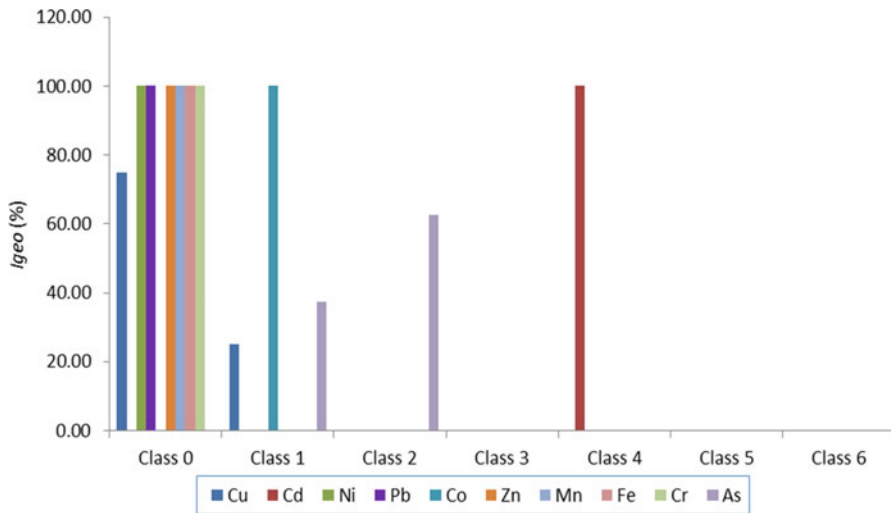

Fig. 4.1 Variations in Geoaccumulation index (I_{geo}) of total trace metals

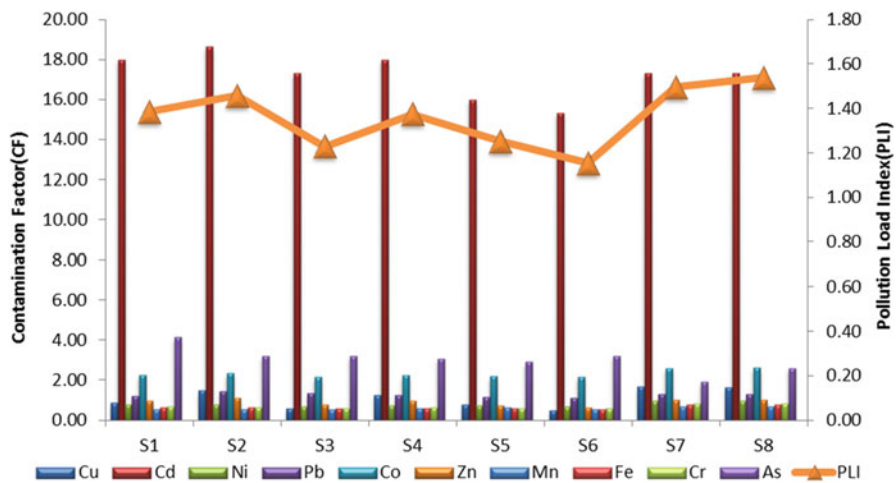

Fig. 4.2 Contamination factor and pollution load index for the total trace metals

at all the sampling sites were Co and As (except Lot 8 (S₇)). Cadmium exhibited “severe to extremely severe enrichment” (EF > 22.38) of the sediment at all the sampling sites which may be attributed to phosphate fertilizers used in the nearby catchment area. The spatial distribution of EF_{Cd} suggested that the major sources of Cd in the surface sediments of the studied area might be different from that of the other studied TMs.

4.3.5 Sediment Quality Guidelines (SQGs)

According to US NOAA's sediment quality guidelines (SQGs), it was observed that the total trace metal concentrations of Cu (at all sampling sites), Cd (at all sampling sites), Ni (at S₃, S₄, S₅, and S₆), and As (at all sampling sites) have exceeded the effects range-low values indicating ecotoxicological risk to the macrozoobenthos (e.g., polychaetes, gastropods, and bivalve mollusks) would be occasionally observed. Nickel concentrations at S₁, S₂, S₇, and S₈ were above effects range median implying adverse biological effects.

When compared to the TEL–PEL SQGs, the concentrations of Cu, Cr, and As fall in the range between TEL and PEL with 100%, 100%, and 50% of the sampling sites. The concentrations of Cd and Ni at all the sampling sites have exceeded the probable effects level (PEL) indicating potential harm for aquatic organisms. Arsenic had exceeded PEL values at 50% of the sampling sites.

4.3.6 Statistical Analyses

4.3.6.1 Factor Analysis

The associations of geochemical elements were determined for both TMs and ALTMs (Fig. 4.3a, b). The factors were generated applying the varimax rotation matrix based on the eigenvalues (more than 1). The factor analysis for TMs indicates a cumulative percentage of 83.18 with two factors, and for ALTMs, it was 89.16% with three factors. Factor 1 in both TMs and ALTMs can be termed as “Fe–Mn oxide factor” as it is associated with Cr, Cu, Ni, and Co (in both fractions) and Pb, Cd, and Zn for ALTMs alone. Factor 2 for both TMs and ALTMs can be termed as “anthropogenic factor,” where positive values are seen in Pb and Cd (for TMs), Cu and Zn (for ALTMs), and a strong negative behavior of As (in ALTMs) suggesting that all the trace metals are associated within each other except As. The separate behavior of As is especially due to the following reasons: (i) extensive use of pesticides in the region (e.g., Dushenkov and Kapulnik 2000), (ii) use in smelting industries, and (iii) the sulfide ores (carbon deposits) which occur naturally in the upstream side of the river (e.g., Bradl 2005).

4.3.6.2 Correlation Coefficient

Results of correlation matrix showed diverse positive correlations as follows: Cd with Cu ($r = 0.74$; $p \leq 0.05$), Pb ($r = 0.79$; $p \leq 0.05$), Ni ($r = 0.88$; $p \leq 0.01$), and Co ($r = 0.82$; $p \leq 0.05$); Ni with Cu ($r = 0.81$; $p \leq 0.05$); Co with Cu ($r = 0.72$; $p \leq 0.05$) and Ni ($r = 0.97$; $p \leq 0.01$); Zn with Cu ($r = 0.94$; $p \leq 0.01$); Mn with Cu ($r = 0.72$; $p \leq 0.05$), Cd ($r = 0.80$; $p \leq 0.05$), Ni ($r = 0.92$; $p \leq 0.01$), and Co ($r = 0.86$; $p \leq 0.01$); Fe with Cu ($r = 0.78$; $p \leq 0.05$), Cd ($r = 0.90$; $p \leq 0.01$), Ni ($r = 0.99$; $p \leq 0.01$), Co ($r = 0.95$; $p \leq 0.01$), and Mn ($r = 0.95$; $p \leq 0.01$); and Cr

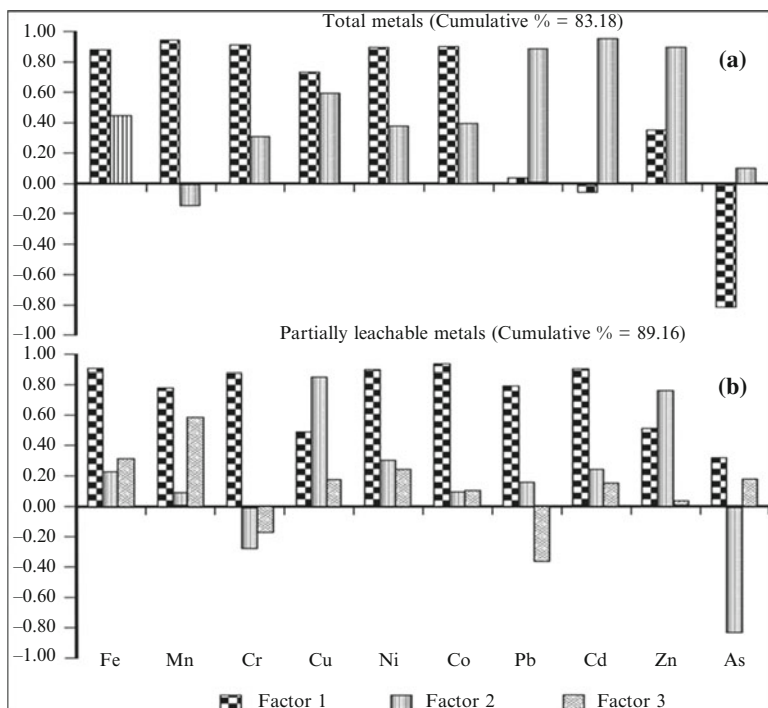

Fig. 4.3 Results of factor analysis for total and acid-leachable trace metals

with Cd ($r = 0.72$; $p \leq 0.05$), Ni ($r = 0.74$; $p \leq 0.05$), Pb ($r = 0.74$; $p \leq 0.05$), Co ($r = 0.82$; $p \leq 0.05$), and Fe ($r = 0.71$; $p \leq 0.05$). Positive correlation between these trace metals suggested that they have a common point of origin, mutual dependence, and identical behavior during transport in the estuarine environment. Acid-leachable fraction of Mn and Fe exhibits significant positive correlation with the trace metals as previously discussed, indicating that the ALTMs in the sediments are mainly combined with Fe–Mn oxyhydroxides. Further in sediments, TMs interact with sediment matrix through different binding mechanisms, including adsorption to mineral surfaces and association with carbonates, Fe/Mn oxyhydroxides, organic matter, sulfides, and the lattices of refractory crystalline minerals such as silicates, exhibiting different environmental behaviors critically dependent on their chemical forms and/or interactions and thus influencing mobility, bioavailability, and toxicity to organisms (Castillo et al. 2013). The significant positive correlation of finer particles (especially with silt) with Cu ($r = 0.62$; $p \leq 0.05$), Ni ($r = 0.59$; $p \leq 0.05$), Co ($r = 0.64$; $p \leq 0.05$), Zn ($r = 0.59$; $p \leq 0.05$), Mn ($r = 0.64$; $p \leq 0.05$), and Fe ($r = 0.59$; $p \leq 0.05$) reveals that the available fractions of the TMs in the sediments mainly exist in the fine particles due

to greater surface adsorption and ionic attraction and that ALTMs are enriched in sediments mainly due to waterborne pollution of different types (Hu et al. 2013).

4.3.7 Comparison of TM Concentration with Other Estuarine Regions

Comparison values of TMs and ALTMs of the present study with that of other regions around the world indicate higher values for most of the TMs (except Zn and As) which could be due to the digestion methodology and in the extreme cases due to the input from industrial developments in the region (Table 4.5). In Indian conditions, the concentration pattern of the TMs varies with reference to the site due to development in the region, but mostly all the metals are on the higher side as uncontrolled input is done in the study area and, moreover, the region rests on one of the metropolitan towns (Kolkata) of India. However, ecotoxicological values indicate that all the mean values of TMs are higher than LEL and higher than unpolluted sediments. The above enrichments clearly suggest that considerable amount of trace metals are available to the marine organisms which could be adsorbed or incorporated into the biological cycle in the near future.

4.4 Conclusion

The work presents an informative and valuable data pertaining to TMs and ALTMs in surface sediments of a tropical meso-macrotidal estuary and provided the characteristics of contamination along with their potential sources. The observed spatial differences are mainly concerned with complex geochemical and biogeochemical processes. Since the concentrations of Cu, Cd, Ni, and As have exceeded the conventional SQG protocol, necessary preventive measures should be adopted to overcome the ecotoxicological risk for the benthos. Most importantly, the toxic metal Pb showed potential toxicity as it could mobilize from the sediment due to higher concentration in the leachable fraction. The coastal environment of West Bengal is considerably constrained due to human-induced stresses like dredging, riverine traffic, industrial and domestic discharges either in semi-treated or untreated forms. Hence, the authors strongly recommend regular monitoring emphasizing on accurate appraisal of the potential risk of metals to this estuarine environment.

Table 4.5 Comparison of trace metal concentrations of the present study with estuarine and mangrove regions around the world along with standard sediment quality guidelines (SQGs)

Study area	Extraction type	Fe	Mn	Cr	Cu	Ni	Co	Pb	Cd	Zn	As	Hg	References
<i>Worldwide rivers, mangroves, and estuary</i>													
Panuco River, Mexico		13,451	607	19.88	21.62	16.56	-	46.11	1.81	92.18	-	-	Jonathan et al. (2013)
Saudi mangrove, Arabian Gulf	HF	-	28.7	-	1.8	-	-	11.8	-	7.3	-	-	Sadiq and Zaidi (1994)
Eastern Scheldt, Est. Netherlands	HF	-	-	109	58	49	-	97	2.0	257	-	-	Beefink et al. (1982)
Illawarra region, S. Australia	HF	50,700	475	69	80	-	-	282	1.1	2163	-	-	Chenhal et al. (1992)
Krka R. estuary, Adriatic coast	Amm. acct.	-	232.2	10.67	16	5.67	0.75	10.8	-	9.67	-	-	Prohic and Kniewald (1987)
Pearl R. estuary, S. China	Amm. acct.	-	-	-	0.01-8.41	-	-	0.08-0.35	-	0.23-1.71	-	-	Li et al. (2000)
Hong Kong mangrove swamps	HNO ₃	14,300	77.88	16.75	22.85	8.68	-	41.09	0.39	81.08	-	-	Tam and Wong (2000)
Bristol Channel, UK	HCl	1600	58-1013	-	8-1860	-	1.4-14.9	22-4760	0.20-0.90	43-2656	-	-	Luoma and Bryan (1981)

Indian rivers, mangroves, and estuary

Yamuna River	Fe-Mn oxide	43.8	31.2	–	23.6	–	–	–	41.1	–	15.8	–	–	Subramanian et al. (1987)
Gulf of Mannar	HOAc	255	82	4.25	–	5.91	5.04	3.06	3.06	0.15	3.60	–	–	Jonathan and Ram Mohan (2003)
Ennore creek core sediments	HOAc	1673	108	5.4	–	3.1	3.0	6.3	6.3	0.11	16.6	–	–	Selvaraj et al. (2003)
Pichavaram mangroves	HCl	1786	55.2	16.24	7.53	7.8	–	24.2	24.2	0.60	11.31	–	–	Lakshumanan (2001)
Thambraparani estuary	HCl	415	79	10.13	11.09	6.92	–	53.98	53.98	0.51	28.21	–	–	Jayaprakash et al. (2014)
Muthupet mangroves	HCl	11,295	611.5	21.76	11.35	21.14	13.95	30.0	30.0	0.79	15.89	–	–	Janaki-Raman et al. (2007)
Sundarban mangroves	HCl	4457	393	13.52	36.60	8.47	–	15.37	15.37	0.015	–	–	–	Jonathan et al. (2010)
Uppanar River, Cuddalore	HCl	1673	26.7	6.79	3.77	3.77	3.03	7.2	7.2	0.39	8.88	–	–	Ayyampertumal et al. (2006)
Present study – total partial	HF	30486.3	511.9	61.69	49.65	54.13	44.29	25.37	25.37	5.18	86.71	39.61	–	–
	HCl	3818.6	71.3	3.89	8.18	3.75	2.73	6.93	6.93	0.20	14.56	5.55	–	–

(continued)

Table 4.5 (continued)

Study area	Extraction type	Fe	Mn	Cr	Cu	Ni	Co	Pb	Cd	Zn	As	Hg	References
<i>Ecotoxicological values</i>													
Unpolluted sediments	-	-	770	-	33	52	-	19	-	95	-	-	Salomons and Forstner (1984)
Effects range low (ERL)	-	-	-	81	34	20.9	-	46.7	-	150	-	-	Long et al. (1995)
Effects range medium (ERM)	-	-	-	370	270	51.6	-	218	-	410	-	-	Long et al. (1995)
Lowest effects level (LEL)	-	-	460	26	16	16	-	31	-	120	-	-	USEPA (2001)
Severe effects level (SEL)	-	-	1110	110	110	75	-	250	-	820	-	-	USEPA (2001)

All values in mg kg⁻¹

References

- Acharyya SK, Lahiri S, Raymahashay BC, Bhowmilk A (2000) Arsenic toxicity of groundwater in parts of the Bengal basin in India and Bangladesh: the role of quaternary stratigraphy and Holocene sea-level fluctuation. *Environ Geol* 39:231–238
- Adriano DC (1986) Trace elements in terrestrial environments. Springer, New York
- Ahmad S, Siddiqui EN, Khalid S (1996) Studies on certain physico chemical properties of soil of two fresh water ponds of Darbhanga. *Environ Pollut* 31:31–39
- Alagarsamy R (2006) Distribution and seasonal variation of trace metals in surface sediments of the Mandovi estuary, west coast of India. *Estuar Coast Shelf Sci* 67:333–339
- Alam MA, Gomes A, Sarkar SK, Shuvaeva OV, Vishnevetskaya NS, Gustaytis MA, Bhattacharya BD, Godhantaraman N (2010) Trace metal bioaccumulation by soft-bottom Polychaetes (Annelida) of Sundarban mangrove Wetland, India and their potential use as contamination indicator. *Bull Environ Contam Toxicol* 85:492–496
- Ayyamperumal T, Jonathan MP, Srinivasalu S, Armstrong-Altrin JS, Ram-Mohan V (2006) Assessment of acid leachable trace metals in sediment cores from River Uppanar, Cuddalore, southeast coast of India. *Environ Poll* 143:34–45
- Banerjee K, Senthikumar B, Purvaja R, Ramesh R (2012) Sedimentation and trace metal distribution in selected locations of Sundarbans mangroves and Hooghly estuary, Northeast coast of India. *Environ Geochem Health* 34(1):27–42
- Beeftink WG, Nieuwenhuizen J, Stoepler M, Mohl C (1982) Heavy metal accumulation in salt marshes from the western and eastern Scheldt. *Sci Total Environ* 25:199–223
- Belabed B, Laffray X, Dhib A, Fertouna-Belakhal M, Turki S, Aleya L (2013) Factors contributing to heavy metal accumulation in sediments and in the intertidal mussel *Perna perna* in the Gulf of Annaba (Algeria). *Mar Pollut Bull* 74:477–489
- Bhuiyan MAH, Parvez L, Islam MA, Dampare SB, Suzuki S (2010) Heavy metal pollution of coal mine-affected agricultural soils in the northern part of Bangladesh. *J Hazard Mater* 173:384–392
- Bradt HB (2005) Arsenic. In: Heavy metals in the environment, vol 6. Academic Press/Elsevier, London, pp 93–98
- Castillo MLA, Trujillo IS, Alonso EV, Torres AGD, Pavón JMC (2013) Bioavailability of heavy metals in water and sediments from a typical Mediterranean Bay (Málaga Bay, Region of Andalucía, Southern Spain). *Mar Pollut Bull* 76:427–434
- Chen WH, Erker BT, Kanematsu M, Darby JL (2010) Disposal of arsenic-laden adsorptive media: economic analysis for California. *J Environ Eng ASCE* 136:1082–1088
- Chenhall BE, Yassini I, Jones BG (1992) Heavy metal concentrations in lagoonal salt marsh species, Illawarra region, southeastern Australia. *Sci Total Environ* 125:203–225
- Decov VM, Subramanian V, Van Grieken R (1999) Chemical composition of riverine suspended matter and sediments from the Indian sub-continent. In: Ittekkot V, Subramanian V, Annadurai S (eds) Biogeochemistry of Rivers in tropical South and Southeast Asia. Heft 82. SCOPE Sonderband. Mitteilugen aus dem Geologisch-Paläontologischen Institut der Universität, Hamburg, pp 99–109
- Dhanakumar S, Rutharvel Murthy K, Solaraj G, Mohanraj R (2013) Heavy-metal fractionation in surface sediments of the Cauvery River Estuarine Region. Southeastern Coast of India *Arch Environ Contam Toxicol* 65:14–23
- Dowling CB, Poreda RJ, Basu AR, Aggarwal PK (2002) Geochemical study of arsenic release mechanisms in the Bengal Basin groundwater. *Water Resour Res* 38(9):1173–1190
- Drik D, Link WP, Kingston HM (1998) Development and validation of the new EPA micro-wave assisted leach method 3051A. *Environ Sci Technol* 32(22):3628–3632
- Duodu GO, Goonetilleke A, Ayokoa GA (2017) Potential bioavailability assessment, source apportionment and ecological risk of heavy metals in the sediment of Brisbane River estuary, Australia. *Mar Pollut Bull* 117:523–531

- Dushenkov S, Kapulnik Y (2000) In: Raskin J, Ensley BD (eds) *Phytoremediation of toxic metals – using plants to clean up the environment*. Wiley, New York, pp 89–106
- El-Bilali L, Rasmussen PE, Hall GEM, Fortin D (2002) Role of sediment composition in trace metal distribution in like sediments. *Appl Geochem* 17(9):1171–1181
- Filgueiras AV (2004) *Extracción secuencial de metales pesados en sedimentos: Desarrollo de métodos rápidos y aplicaciones*. PhD thesis, Facultad de Química, Universidad de Vigo, p 340
- Folk RL, Ward WC (1957) Brazos River bar [Texas]; a study in the significance of grain size parameters. *Int J Sed Res* 27:3–26
- Förstner U (1983) Assessment of metal pollution in river waters and estuaries. In: Thornton I (ed) *Applied Environ Geochem*. Academic, London, pp 395–423
- Gee GW, Bauder JW (1986) Particle-size analysis. In: Klute A (ed) *Methods of soil analysis, part 1*. American Society of Agronomy, Madison, pp 383–412
- Gonzalez-Fernandez D, Garrido-Perez M, Nebot-Sanz E, Sales-Marquez D (2011) Source and fate of heavy metals in marine sediments from a semi-enclosed deep embayment subjected to severe anthropogenic activities. *Water Air Soil Pollut* 1–12
- Hakanson L (1980) An ecological risk index for aquatic pollution control: a sedimentological approach. *J Wat Res* 14:975–1001
- Hu B, Li J, Zhao J, Yang J, Bai F, Dou Y (2013) Heavy metal in surface sediments of the Liaodong Bay, Bohai Sea: distribution, contamination, and sources. *Environ Monit Assess* 185:5071–5083
- Idris AM, Eltayeb MAH, Potgieter-Vermaak SS, Grieken RV, Potgieter JH (2007) Assessment of heavy metals pollution in Sudanese harbours along the Red Sea Coast. *Microchem J* 87:104–112
- Janaki-Raman D, Jonathan MP, Srinivasalu S, Armstrong-Altrin JS, Mohan SP, Ram-Mohan V (2007) Trace metal enrichments in core sediments in Muthupet mangroves, SE coast of India: application of acid leachable technique. *Environ Pollut* 145:245–257
- Jayaprakash M, Arya V, Gopal V, Muthuswamy S, Kalaivanan P, Giridharan L, Jonathan MP (2014) Bioavailable trace metals in micro-tidal Thambraparani estuary, Gulf of Mannar, SE coast of India. *Est Coast Shelf Sci* 146:42–48
- Jonathan MP, Ram Mohan V (2003) Heavy metals in sediments of the inter shelf off the Gulf of Mannar, southeast coast of India. *Mar Pollut Bull* 46:258–268
- Jonathan MP, Sarkar SK, Roy PD, Alam Md A, Chatterjee M, Bhattacharya BD, Bhattacharya A, Satpathy KK (2010) Acid leachable trace metals in sediment cores from Sunderban Mangrove Wetland, India: an approach towards regular monitoring. *Ecotoxicology* 19:405–418
- Jonathan MP, Roy PD, Rodríguez-Espinosa PF, Sarkar SK, Muñoz-Sevilla NP, Navarrete-López M, Srinivasalu S, Thangadurai N (2013) Evaluation of trace element concentration (acid leachable) in sediments from River Pánuco and its adjacent lagoon areas, NE México. *Environ Earth Sci* 68:2239–2252
- Kabata-Pendias A (2010) *Trace elements in soils and plants*, 4th edn. CRC Press, Boca Raton
- Lakshumanan C (2001) *Modeling organic carbon deposition, degradation and preservation in sediments of Pichavaram mangrove wetlands, southeast coast of India* (unpublished Ph.D. thesis) Anna University, Chennai, India, 178
- Li X, Wai OWH, Li YS, Coles BJ, Ramsey MH, Thornton I (2000) Heavy metal distribution in sediment profiles of the Pearl River estuary, South China. *Appl Geochem* 15:567–581
- Liu B, Hu K, Jiang Z, Yang J, Luo X, Liu A (2011) Distribution and enrichment of heavy metals in a sediment core from the Pearl River Estuary. *Environ Earth Sci* 62:265–275
- Long ER, Morgan LG (1990) *The potential for biological effects of sediment-sorbed contaminants tested in the national status and trends program*. NOAA Technical Memorandum NOS OMA 52. National Oceanic and Atmospheric Administration. Seattle, Washington
- Long ER, Mac Donald DD, Smith SL, Calder FD (1995) Incidence of adverse biological effects within ranges of chemical concentrations in marine and estuarine sediments. *Environ Manag* 19:81–97

- Long ER, Field LJ, MacDonald DD (1998) Predicting toxicity in marine sediments with numerical sediment quality guidelines. *Environ Toxicol Chem* 17:714–727
- Luoma SN, Bryan SW (1981) A statistical assessment of the form of trace metals in oxidized estuarine sediments employing chemical extractants. *Sci Total Environ* 17:165–196
- Ma X, Zuo H, Tian M, Zhang L, Meng J, Zhou X, Min N, Chang X, Liu Y (2016) Assessment of heavy metals contamination in sediments from three adjacent regions of the Yellow River using metal chemical fractions and multivariate analysis techniques. *Chemosphere* 144:264–272
- Macdonald DD, Carr RS, Calder FD, Long ER, Ingersoll CG (1996) Development and evaluation of sediment quality guidelines for Florida coastal waters. *Ecotoxicology* 5:253–278
- MacDonald DD, Ingersoll CG, Berger TA (2000) Development and evaluation of consensus-based sediment quality guidelines for freshwater ecosystems. *Arch Environ Contam Toxicol* 39:20–31
- Marmolejo-Rodriguez AJ, Prego R, Meyer-Willerer A, Shumilin E, Cobelo-Garcia A (2007) Total and labile metals in surface sediments of the tropical river-estuary system of Marabasco (Pacific coast of Mexico): influence of an iron mine. *Mar Pollut Bull* 55:459–468
- Memet V (2011) Assessment of heavy metal contamination in sediments of the Tigris River (Turkey) using pollution indices and multivariate statistical techniques. *J Hazard Mater* 195:355–364
- Monbet P (2006) Mass balance of lead through a small macrotidal estuary: the Morlaix River estuary (Brittany, France). *Mar Chem* 98:59–80
- Morelli G, Gasparon M (2014) Metal contamination of estuarine intertidal sediments of Moreton Bay, Australia. *Mar Pollut Bull* 89:435–443
- Muller G (1981) Die Schwermetallbelastung der sedimente des Neckars und seiner Nebenflüsse: eine Bestandsaufnahme. *Chem Zeitung* 105:157–164
- Nair RR, Hashimi NH, Rao VP (1982) On the possibility of high-velocity tidal streams as dynamic barriers to longshore sediment transport: evidence from the continental shelf off the Gulf of Kutch, India. *Mar Geol* 47:77–86
- Nasr SM, Soliman NF, Khairy MA, Okbah MA (2015) Metals bioavailability in surface sediments off Nile delta, Egypt: application of acid leachable metals and sequential extraction techniques. *Environ Monit Assess* 187:312
- Navarrete-López M, Jonathan MP, Salgado-Galeana JA, Rodríguez-Espinosa PF (2012) Analysis of leached trace metals in natural soils and sediments using autoclave method. *Environ Monit Assess* 184(4):2285–2293
- Nobi EP, Dilipan E, Thangaradjou T, Sivakumar K, Kannan L (2010) Geochemical and geo-statistical assessment of heavy metal concentration in the sediments of different coastal ecosystems of Andaman Islands, India. *Estuar Coast Shelf Sci* 87:253–264
- Peijnenburg W, Zablotkaja M, Vijver MG (2007) Monitoring metals in terrestrial environments within a bioavailability framework and focus on soil extraction. *Ecotoxicol Environ Saf* 67:163–179
- Prohic E, Kniewald G (1987) Heavy metal distribution in recent sediments of the Krka River estuary: an example of sequential extraction analysis. *Mar Chem* 22:279–297
- Rubio B, Nombela MA, Vilas F (2000) Geochemistry of major and trace elements in sediments of the Ria de Vigo (NW Spain): an assessment of metal pollution. *Mar Pollut Bull* 40:968–980
- Sadiq M, Zaidi TH (1994) Sediment composition and metal concentration in mangrove leaves from the sandy coasts of the Arabian Gulf. *Sci Total Environ* 155:1–8
- Sakan SM, Djordjevic DS, Manojlovic DD, Polic PS (2009) Assessment of heavy metal pollutants accumulation in the Tisza river sediments. *J Environ Manag* 90:3382–3390
- Salomons W, Förstner U (1984) *Metals in hydrocycle*. Springer, Berlin/Heidelberg/New York, pp 63–98
- Sarkar SK, Bilinski SF, Bhattacharya A, Saha M, Bilinski H (2004) Levels of elements in the surficial estuarine sediments of the Hugli River, northeast India and their environmental implications. *Environ Int* 30:1089–1098

- Satpathy K, Mohanty A, Prasad M, Natesan U, Sarkar S (2012) Studies on the variations of heavy metals in the marine sediments off Kalpakkam, East Coast of India. *Environ Earth Sci* 65:89–101
- Sawlan JJ, Murray JW (1983) Trace metal remobilization in the interstitial waters of red clay and hemipelagic marine sediments. *Earth Planet Sci Lett* 64:213–230
- Selvaraj K, RamMohan V, Srinivasalu S, Jonathan MP, Siddartha R (2003) Distribution of non-detrital trace metals in sediments cores from Ennore creek, southeast coast of India. *J Geol Soc India* 62:191–204
- Siegel FR (2002) *Environmental geochemistry of potentially toxic metals*. Springer, Berlin, p 218
- Sokal RR, Rohlf JF (1981) *Biometry: the principles and practice of statistics in biological research*, 2nd edn. W. H Freeman and Company, San Francisco, 859p
- Subramanian V, Van Grieken R, Van't Dack L (1987) Heavy metal distributions in the sediments of Ganges and Brahmaputra rivers. *Environ Geol Water Sci* 9:93–103
- Sundaray SK, Nayak BB, Lin S, Bhatta D (2011) Geochemical speciation and risk assessment of heavy metals in the river estuarine sediments-a case study: Mahanadi basin, India. *J Hazard Mater* 186:1837–1846
- Sunil Kumar R (1996) Distribution of organic carbon in the sediments of Cochin mangroves, south west coast of India. *Indian J Mar Sci* 25:274–276
- Tam NFY, Wong YS (2000) Spatial variation of heavy metals in surface sediments of Hong Kong mangrove swamps. *Environ Pollut* 110:195–205
- Tessier A, Campbell PGC, Bisson M (1979) Sequential extraction procedure for the speciation of particulate trace metals. *Anal Chem* 51:844–851
- Tomlinson DC, Wilson JG, Harris CR, Jeffrey DW (1980) Problems in the assessment of heavy metals in estuaries and the formation pollution index. *Helgoland Mar Res* 33:566–575
- Tumer A, Olsen YS (2000) Chemical versus enzymatic digestion of contaminated estuarine sediment: relative importance of iron and manganese oxides in controlling trace metal bio-availability. *Estuar Coast Shelf Sci* 51:717–728
- Turekian KK, Wedepohl KH (1961) Distribution of the elements in some major units of the earth's crust. *Bull Geol Soc Am* 72:175–192
- UNEP/MAP (2012) *State of the mediterranean marine and coastal environment*. UNEP/MAP-Barcelona Convention, Athens, pp 0–96
- United States Environmental Protection Agency (USEPA) (2001) *The role of screening-level risk assessments and refining contaminants of concern in Baseline ecological risk assessments*, Publication 9345 0-14, EPA 540/F-01/14, June, 2001
- Violante CV, Perelomov L, Caporale AG, Pigna M (2010) Mobility and bioavailability of heavy metals and metalloids in soil environments. *J Soil Sci Plant Nutr* 10(3):268–292
- Walkey A, Black TA (1934) An examination of the Dugtijaraff method for determining soil organic matter and proposed modification of the chronic and titration method. *Soil Sci* 37:23–38
- Wang ZH, Feng J, Jiang T, Gu YG (2013) Assessment of metal contamination in surface sediments from Zhelin Bay, the South China Sea. *Mar Pollut Bull* 76:383–388
- Zaaboub N, Martins MVA, Dhib A, Bejaoui B, Galgani F, Bour ME, Aleya L (2015) Accumulation of trace metals in sediments in a Mediterranean Lagoon: usefulness of metal sediment fractionation and elutriate toxicity assessment. *Environ Pollut* 207:226–237

Abstract

The use of bioindicator organisms for the biomonitoring of heavy metal toxicity and their ecological effects draws special attention. Many marine invertebrate species fulfill the following criteria: sensitivity to a wide range of inorganic contaminants (especially to heavy metals), cost-effectiveness for repeatable tests, and readily interpretable biological consequences of pollution. Among the potential marine invertebrates used as bioindicators, littoral benthic species form key components to address the metal bioavailability. Polychaetes (Annelida) are the dominant component of soft-bottom macroinvertebrate communities, forming a potential macrozoobenthos group. The chapter has been designed to investigate the trace metal bioaccumulation strategies in diverse macrozoobenthos groups (polychaetous annelids and bivalve and gastropod mollusks) along with the host sediments from the intertidal regions of Indian Sundarban mangrove wetland. The suitability of using these organisms in biomonitoring of heavy metals has been elaborated with the present research findings. Both species-dependent variability and temporal variations were pronounced. A high degree of organ specificity was evident in the bivalves where gill and mantle exhibited higher metal accumulation due to ion exchange property of the mucous layer covering these organs while shells represent very poor accumulation. The organisms are differentially selective for a range of metals, and these variations might be influenced by a number of intrinsic and extrinsic factors. Moreover, the concentration of heavy metals in the tissues of marine invertebrates depends on the accumulation strategy adopted by each species for each metal. The enrichment of Mn (maximum 730 mg kg^{-1}) and Zn (maximum 320 mg kg^{-1}) was recorded for all the polychaetes followed by Cr, Cu, As, Co, Ni, and Pb, showing sharp variations between the species. However, concentrations of Sn and Hg were very low with small variations between the species. An overall high bioconcentration factor (BCF) was recorded in the capitellid worm *Mastobranthus indicus*. The results of the investigation indicate metal bioaccumulation in these macrozoobenthos group

has the potential for use in any future regulatory framework monitoring and eventually controlling ambient metal pollution levels.

Keywords

Macrozoobenthos • Polychaetes • Molluskan shellfishes • Bioaccumulation • Bioindicator • Trace metals • Sundarban wetland

5.1 Introduction

Invertebrates occupy a key position as intermediate consumers in the pelagic as well as benthic food chains of aquatic ecosystems. Then, aquatic organisms may represent excellent bioindicators of the marine water quality. The main purpose of monitoring the concentrations of heavy metals in biota is to determine the toxicological risk faced by marine organisms and even by humans through the ingestion of contaminated edible species. The use of particular organisms as biomonitors of heavy metal bioavailability in coastal water allows comparisons to be made over space and time, as biomonitors provide integrated measures of the ecotoxicologically significant fraction of ambient metal in water (Phillips and Rainbow 1993; Rainbow 1995). Biomonitors generally accumulate heavy metals to concentrations that are relatively easy to measure, since they concentrate metals continuously, often several orders of magnitude above ambient water concentrations. Essential characteristics required of biomonitors include the capacity to accumulate pollutants without being killed by the encountered levels and their sedentary nature in order to be representative of the area. In addition, biomonitors should be abundant in the area of study, be sufficiently long-lived, and be of a reasonable size to provide enough tissue for analysis. Polychaetous annelids fulfill all these criteria mentioned above, and the suitability of these organisms in the measurement of bioavailable contaminants has been established in measuring, monitoring, and research programs.

Crustaceans inhabiting sandy beaches around the globe appear in biomonitoring programs with increasing frequency. Recently, Fialkowski and Rainbow (2016) asserted the usefulness of *Talitrus saltator*, the talitrid amphipod crustacean, as a convenient biomonitoring species of trace metal bioavailability in coastal waters, by working on the distributional range of the species in the Baltic Sea. Among the abiotic matrices, avian feathers can be used as reliable noninvasive bioindicator for monitoring heavy metal accumulation in seabirds and the marine environments (Markowski et al. 2013). Mercury levels in scalp hair are a frequently used marker of mercury exposure in humans, and this has been confirmed from extensive researches done by Masih et al. (2016) and Diez et al. (2011).

Polychaetes are one of the most significant functional groups of benthic macrozoobenthos (MZ) in shallow marine habitats and mostly abundant in benthic communities, exhibiting a high stability and adaptability to different environmental conditions. These worms are pivotal parts of food webs, multiplying trophic

connections with their richness, abundance, and diverse feeding strategies (Fauchald 1977), and they serve as an important descriptor of environmental conditions (Samuelson 2001). These MZ are widely used for biomonitoring contamination in coastal waters throughout the world and for environmental risk assessments, as this group was proved to tolerate a high burden of heavy metals within their tissues. The potential effect of trace metals, including toxic ones, on this benthic group is of ecological importance (Sato and Nakashima 2003; Zhou et al. 2004) since these species come in direct contact with the sediments (Hutchings 1998; Olsgard and Somerfield 2000).

In addition, intertidal mollusks, especially gastropods and bivalves, are key components of the local littoral MZ and have given due importance to address the metal bioavailabilities. Metal bioaccumulation in these dominant organisms has the potential for use in any future regulatory framework monitoring and eventually controlling ambient metal pollution levels.

There has been dearth of studies on documenting sediment-based bioaccumulation of trace metals by these MZ groups. Hence the present chapter is dealt with a detailed account to assess the efficiency of these groups for bioaccumulation of trace metals and also to evaluate the use of any species of this group as bioindicator species.

5.1.1 In Situ Biological Monitors

A good number of key monitoring species, both plants and animals, are frequently used to evaluate the spatiotemporal variations in metal bioavailability in the marine and estuarine environment. In situ monitoring species or biomonitors are essential in assessing the impacts of contamination on the environment and should fulfill the following criteria if they are to be used successfully:

1. Sedentary or sessile in nature, so that they could represent the area sampled.
2. Contaminants should be accumulated without lethal impacts to the concerned bioindicator species and should be robust enough for experimental design in pollution field investigations.
3. Abundant throughout the year, widely distributed, and sufficiently long-lived to allow the sampling more than 1 year, if required. They should be properly identified, common, and easily collected for further comparison between monitoring sites.
4. Dependent on the species, they are able to reflect metal availability in different sub-environments and in different fractions in the water. For example, generally seaweeds can absorb dissolved metals from seawater whereas suspension feeders (e.g., bivalve mollusks) respond to metals both dissolved in the water and bound to particulate matter (Rainbow 1995; Wang et al. 1996).

Typical bioindicators or “sentinel” species for assessment of metal bioavailability are bivalve mollusks, seaweeds, amphipods, and relatively stationary/sedentary fish such as

sculpins (Rainbow 1995; Rig  t et al. 2007; Golding et al. 2013). An important advantage of the use of monitoring species is that they provide a time-integrated measure of the metal availability in the environment they inhabit depending on their uptake and exclusion mechanisms (Rainbow 1995). However, the application of such species for monitoring purposes has certain complications, e.g., due to the species-specific regulator mechanisms for some metals such as zinc and copper (Rainbow 1995).

5.2 Methodology

5.2.1 Collection of Research Samples

Five sampling sites in tidal mudflats of Sundarban coastal regions have been selected characterized with diverse geomorphological features and environmental stresses, namely, Haribhanga, Gangasagar, Chemaguri, Mayagoalinir Ghat, and Ghushighata. The sampling sites belong to the northern and southern extremities of Sundarban with contrasting tidal environments, wave energy fluxes, distance from the sea (Bay of Bengal), and differential human interferences. These contrasting habitats were selected in order to find out the sensitiveness in the behavior of polychaete communities to different environmental conditions. The four soft-bottom benthic polychaete species were collected from mean high water and mean low water lines from the above-referred sites: (1) *Namalycastis fauveli* (family: Nereididae), (2) *Dendronerides arborifera* (family: Nereididae), (3) *Perinereis cultrifera* (family: Nereididae), and (4) *Mastobranchus indicus* (family: Capitellidae). Regarding feeding guilds, the first three species are omnivorous while the last one is surface-deposit feeders.

Similarly, the following representative molluskan shellfishes were selected as they provided diverse exposure levels of contaminant uptake. The filter-feeder bivalves *Macoma birmanica* (family Tellinidae) and *Crassostrea cucullata* (family Ostreidae) along with the gastropods (namely, *Littorina littorea*, *Telescopium telescopium*, and *Cerithidea cingulata*) were collected at low tides from the intertidal zone for further studies. The representatives of soft-bottom dominant polychaetes and gastropod mollusks have been shown in Figs. 5.1 and 5.2.

5.2.2 Analytical Protocol

The studied biota samples were collected from mean high water and mean low water lines. For trace metal analyses, 20 congeneric species of uniform size (Simpson 1979) were collected from each station, transported to the laboratory in acid-washed plastic containers (Moody and Lindstrom 1977), rinsed free of mucus and sediments with seawater, depurated properly for 2–3 days (defecation of sediments and any undigested materials), and dried to a constant weight at 60 °C. Samples were pulverized and homogenized in a Teflon mortar. The host sediment

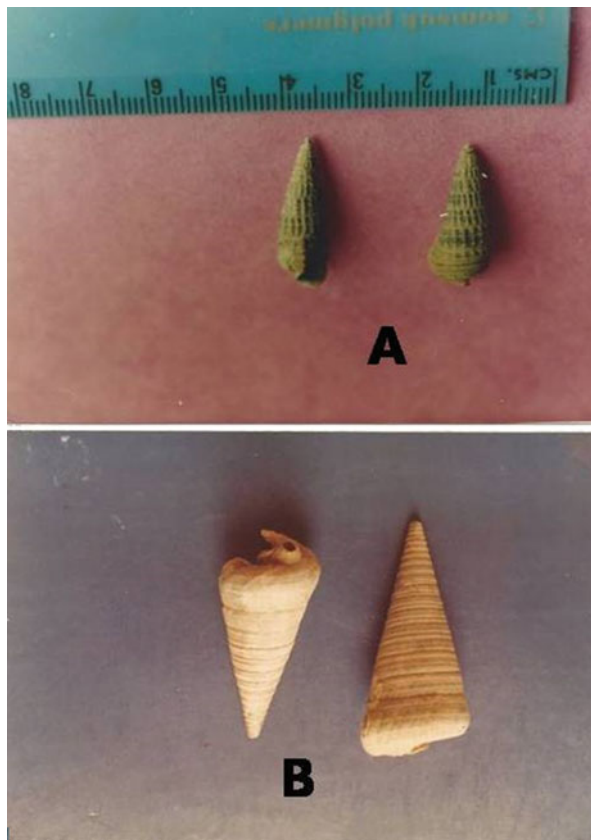

Fig. 5.1 Representative of soft-bottom dominant polychaetes identified from Sundarban

samples of the respective study sites were simultaneously collected from all the sampling sites, using a Peterson grab, and transported to the laboratory in acid-wash plastic containers (Moody and Lindstrom 1977). Then the sediment was wet sieved (63 μm) since this fraction contains more sorbed metal per gram of sediment due to its larger specific surface area and subsequently oven dried at 50 $^{\circ}\text{C}$. The fraction < 63 μm has been recommended for pollutant studies especially with respect to trace metals (Foster 2004). Organic carbon (C_{org}) content of the soil was determined employing a rapid titration method (in chronic acid environment) (Walkey and Black 1934). pH was measured with the help of a deluxe pH meter (model no. 101E) using combination glass electrode manufactured by M.S. Electronics (India) Pvt. Ltd. Mechanical analysis of sediment were done by sieving in a Ro-Tap Shaker (Krumbein and Pettijohn 1938) manufactured by W.S. Tyler Company, Cleveland, Ohio, and statistical computation of texture parameters was done by using the formulae of Folk and Ward (1957) and following standards of Friedman and Sanders (1978). Salinity was measured in situ with the help of a refractometer.

Bioessential metals (Mn and Zn) and trace elements (Cr, Cu, As, Co, Ni, and Pb) in sediments and biota samples were determined by Direct current plasma atomic emission spectrometry (DCP-AES) using the instrument PGS-2 (Carl Zeiss Jena, Germany). The mercury atomic absorption (AA) analyzer RA-915+ of Lumex Ltd. (St. Petersburg, Russia) with a pyrolytical attachment RP-91C was used for direct mercury determination in both sediments and polychaete samples

Fig. 5.2 Representative of the two gastropod species inhabiting in the tidal mudflat of Sundarban: (a) *Cerithidea cingulata* and (b) *Telescopium telescopium*



(Ganeev et al. 1995). The detection limits for Cd, Pb, As, Ni, Cr, Hg, and Cu were 10, 10, 0.5, 10, 20, 0.5, and 10 $\mu\text{g/g}$, respectively. The non-selective absorption of the sample was controlled in the dynamic regime with Zeeman correction in the instrument. Sample preparation procedure for DCP-AES analysis included the following steps: (1) homogenization of the sample with graphite powder (1:1) in organic glass mortar, (2) ashing the mixture at 450 °C during 3 h, and (3) successive dilution of homogenized samples with graphite powder and magnesium oxide MgO to prevent As loss at the ashing stage, providing its content in each subsample at the level of 10%. DCP-AES analysis: 20 mg of the subsamples with dilution of 4 and 8 prepared according to abovementioned procedure were placed into the cavity of graphite electrode. A unified series of reference samples was prepared on the base of graphite powder containing 10% of MgO. The average values of two results for each subsample with dilutions 4 and 8 were considered as ultimate ones. Quality assurance: certified reference materials (River Sediment BCR-320 as well as Dogfish Liver DOLT-2) were used to ensure the quality control and accuracy of the analyses. Certified reference materials (Sediment BCR-320 for sediment and Dogfish Liver DOLT-2 for biota) were concurrently analyzed to maintain the

quality control and accuracy of the analyses; the recovery rates for trace metals in the standard reference material ranged between 7 and 112% for sediments and 77 and 125% for biota.

5.3 Results and Discussion

5.3.1 Sediment Geochemical Characteristics

The sediment quality parameters of five sampling sites of Sundarban wetland exhibit variations, as depicted in Table 5.1. Soil temperature showed minimum value of 20.5 °C (during monsoon) to a maximum of 29.5 °C (during pre-monsoon) resulting from seasonal effects in a tropical system. Values of pH range from slightly acidic to basic (range from 7.7 to 8.4) where the acidic nature is recorded as a solitary case for Ghushighata (during monsoon 2008). This is partly due to the oxidation of FeS₂ and FeS to SO₄²⁻ and partly results from the decomposition of mangrove litter and hydrolysis of tannin in mangrove plants releasing various kinds of organic acids (Liao 1990). Organic carbon (C_{org}) values were below 1% in all the stations except at Gangasagar. One of the features of C_{org} in the sediments is that the concentration increases as the particle size of the sediment decreases. The finer particles (silt + clay) showed an efficacious relationship with C_{org} while the coarser fraction has no patent kinship. There exists strong positive correlations between organic carbon and clay particles ($p < 0.01$) which demonstrates adsorbability and efficacy of fine-grained particles for organic carbon. Regarding textural composition, the five stations also exhibit wide variations, such as sandy silty clay at Haribhanga, sandy clay at Gangasagar, and silty clay for the rest of three stations.

Table 5.1 Sediment quality characteristics of the five sampling sites of Sundarban wetland

Sites	Seasons	Temp (°C)	pH	C_{org} (%)	Sand (%)	Silt (%)	Clay (%)
Haribhanga	POM	21	8.1	0.4	23.65	62.05	14.3
	PRM	29	8.4	0.46	39.3	44.25	16.45
Gangasagar	PRM	28.5	8.4	0.22	32.85	58.45	8.7
Chemaguri	POM	24	8.1	0.55	22.8	67.7	9.5
	PRM	26	8	0.69	1.3	51.6	47.1
	M	20.5	8.2	0.89	0.8	84.74	14.46
Mayagoalinir Ghat	PRM	27	8	0.57	9.45	69.78	20.77
	M	20.5	8.3	0.73	0.35	49.68	49.97
Ghushighata	PRM	29.5	8	1.03	11.85	30.85	57.3
	M	24.5	7.7	1.44	2.7	47.25	50.05

POM postmonsoon, *PRM* pre-monsoon, *M* monsoon

5.3.2 Pattern of Trace Metal Accumulation in Macrozoobenthos

5.3.2.1 Trace Metals in Benthic Polychaetes

Marine invertebrates show different accumulation strategies that vary intraspecifically with different trace metals and are potentially predetermined by the rate of uptake of the metals (Rainbow 1990). Among the 11 trace metals examined, the maximum differences in metal concentration in the four polychaete species were found for Mn, Zn, Cu, and As (as shown in Table 5.2) which are also well marked in concentration of metals in sediments. Both the metals, Mn and Zn, showed their maximum values of 730 mg kg^{-1} and 320 mg kg^{-1} , respectively, in *M. indicus* at the site Chemaguri. The elevated values of these bioessential elements are expected as they play an important role in the metabolic processes of these organisms. Moreover, Cu has an important biochemical role as an enzyme activator as a consistent of flavoprotein (Mahler 1956). The elevated levels of Cu and Zn in the polychaete tissues are likely to be associated with antifouling paint residues arising from boat maintenance and vessel repair activities by the coastal people. The consistent higher values of these two elements in all the studied polychaetes suggest that these two have a high potential for biomagnifications during their transfer to the top predators. The elevated level of Cu in *P. cultrifera* of 52 mg kg^{-1} (at sampling site Gangasagar) may also be involved in the deterrence of predators (Gibbs et al. 1981). Physiological differences can also result in marked differences in trace metal accumulation. For example, nereid worm can regulate Zn while Cu is accumulated and stored in membrane-bound vesicles rather than being excreted (Depledge and Rainbow 1990). Recently, Sayed et al. (2017) evaluated the accumulation efficiency and sensitivity of the nereid polychaete *Nereis succinea* to heavy metal pollutants collected from the Red Sea and suggested its possible use as biological monitor for metal contaminants at marine habitats. The body Zn concentrations of all the four polychaete species are relatively independent of ambient concentrations and appear to be internally regulated. This might be attributed to the weak net accumulation through partial regulation of trace elements as observed in accumulation of Zn in the polychaete *Nereis (Hediste) diversicolor* (Amiard et al. 1987). The results of correlation coefficient matrix show that both Mn and Zn are positively and significantly correlated (either 5% or 1% level) with majority of the metals suggesting a common source or chemical similarity. Regarding arsenic, interspecific variations are pronounced where the minimum value of 4.9 mg kg^{-1} in *N. fauveli* was almost four times less than that of *P. cultrifera* where the maximum value of 21 mg kg^{-1} was recorded. This elevated level of arsenic in *P. cultrifera* may be involved in the deterrence of predators (Gibbs et al. 1983). Concentrations in polychaete species reflect total As loads in bottom sediments. Therefore, some species may serve as suitable biological indicators of the availability of sediment-bound arsenic, ascertained by Bryan and Langston (1992). However, it is difficult to ascertain the differences in arsenic bioaccumulation among the five sites of very different sediment chemistry as endorsed by Casado-Martinez et al. (2010). Arsenic concentration in sediments exceeded the sediment criterion (where ER-L value for arsenic is 8.2 mg kg^{-1}) for all the samples and thus is expected to increase the incidence of adverse negative effects on living resources from rare to occasional.

Table 5.2 Trace metal concentrations in polychaete body tissues and adjacent sediments of five sites of Sundarban wetland (mg kg⁻¹)

Sites	Seasons	Species	Mn	Zn	As	Cd	Co	Cr	Cu	Ni	Pb	Sn	Hg
S ₁	POM	<i>P. cultrifera</i>	380	220	21	0.65	13.2	45	39	33	15	1.7	0.05
		Sediment	650	95	36.3	0.21	24.5	52.5	53.3	51.9	22.6	3.9	0.03
S ₂	PRM	<i>P. cultrifera</i>	650	220	17	0.6	16.2	45	36.5	33	18.5	2.5	0.08
		Sediment	580	75	22.6	0.22	22.6	55	40	39.6	16.2	1.7	0.04
S ₃	POM	<i>P. cultrifera</i>	180	140	7	0.55	10.6	14.7	52	23	5.1	1.4	0.2
		Sediment	460	74	26.1	0.16	22	63	40.3	35.6	17.4	4.6	0.03
S ₄	PRM	<i>M. indicus</i>	460	150	16.9	0.6	13	43	44.5	32	17	2.3	0.08
		Sediment	560	149	27	0.2	24.2	65	46	51	26.3	5.2	0.03
S ₅	M	<i>M. indicus</i>	420	180	13.5	0.6	10.2	38	35.5	25	22	0.8	0.07
		Sediment	600	190	22.2	0.16	22	57	41.5	39.2	28.2	2.1	0.02
S ₄	PRM	<i>M. indicus</i>	730	320	17.6	0.65	15	46	40	39	23	4	0.28
		Sediment	530	114	28.8	0.25	23.8	50	74.6	42.8	25.8	5.5	0.04
S ₄	M	<i>N. fauveli</i>	70	85	4.9	0.2	8.6	8.5	31	7.5	2.2	0.5	0.2
		Sediment	400	75	14.8	0.16	23.4	65	46.4	40	23.4	1.6	0.03
S ₅	PRM	<i>M. indicus</i>	650	200	12.5	0.8	13.1	55	37	32.5	23	4.2	0.2
		Sediment	640	133	19.4	0.18	24.2	70.6	62.4	48.7	28	6.4	0.05
S ₅	M	<i>D. arborifera</i>	160	140	9.5	0.4	4.8	4.8	33	7.8	0.95	0.5	0.15
		Sediment	350	95	29.4	0.5	23.8	143	37.5	43.3	25.3	4.7	0.05
S ₅	M	<i>M. indicus</i>	180	230	11	2	6.4	105	25	18	4.4	1	0.17
		Sediment	350	104	32.3	2.2	22.6	149	36.2	33.9	23.5	4.1	0.05

S₁, Haribhanga, S₂ Gangasagar, S₃ Chemaguri, S₄ Mayagoalinir Ghat, S₅ Ghushighata
 POM postmonsoon, PRM pre-monsoon, M monsoon

Cadmium is a non-essential metal which is not regulated metabolically or eliminated in organisms in comparison to essential metals (Cu and Zn) (Fernandes et al. 2007). Interestingly, the concentration of Cd has been found to be much greater in the majority of the polychaete samples in comparison to the sediment. Cadmium is present in the sediments at a trace level (ranges from 0.16 to 2.2 mg kg⁻¹), but it was readily accumulated in polychaetes much higher than adjacent sediments. This indicates their excellent accumulation capacity which might cause acute toxicity to other organisms and human being through marine food chain. Zhou et al. (2004) have observed that Cd accumulation in the polychaete *H. japonica*, in terms of the amount and exposure time, suggests a passive regulation for Cd accumulation occurring in this species.

The capitellid worm *M. indicus* at Chemaguri accumulated maximum concentration of Cr (105 mg kg⁻¹) and may be considered as potential Cr accumulators in comparison with the rest of the polychaete species. The highly elevated chromium level at this site might be due to the mixing of tannery effluents in the sewage canal from the adjacent tanneries containing high toxic chromium compounds along with high organic matter and salt content. The elevated level of Cr in the body tissues of the same capitellid worm was recorded at this site (164 mg kg⁻¹) (Sarkar et al. 2004), which is in conformity with the present findings. It is worthwhile to mention that the chromium content in sediments was also high at this site (143–149 mg kg⁻¹) which is above the ER-L value and may possess some ecotoxicological risks to organisms living in sediments. Copper is one of the most common contaminants found at high concentrations in aquatic environments, and thus the aquatic biotas are being exposed to elevated levels of copper. In contrast to Cd, Cu is an essential element for the subsistence of many animals. This is a component of many metalloenzymes and respiratory pigments, playing a significant role in cellular metabolism activities (Cousins 1985).

Accumulation of Pb in polychaete tissues exhibited an erratic pattern where the low values were recorded in *P. cultrifera* (at Gangasagar) (0.95 mg kg⁻¹) as well as *N. fauveli* (at Mayagoalinir Ghat) (23 mg kg⁻¹). The accumulation of Pb in the individual polychaete species was found to be lower than those found in the adjacent sediments (Table 5.2) which endorse previous findings while studying gastropod, bivalve mollusks, and fishes from Sundarban environment (Saha et al. 2006).

Concentrations of three potential pollutants, Cd, Sn, and Hg, exhibited a lower degree of accumulation in all the polychaete species than the rest of the eight metals. This might be related to the unique adaptive strategies of these worms by secreting mucus in response to these metals which help in reducing metal availability for uptake. This was demonstrated experimentally by Mouneyrac et al. (2003) on the polychaete *H. diversicolor*. Many parameters may affect the mercury accumulation, such as specimen size, sexual maturity, feeding habits, trophic position, water quality, and environmental contamination (Kehrig et al. 1998). Even closely related species may be feeding on subtly different food sources with consequently different inputs of metals for accumulation (Rainbow 1995). It is, thus, not surprising that the polychaete species do not have similar metal body

burdens even when present together at the same site. BAF was determined as a ratio between the concentrations of metal in the organism (mg kg^{-1} dry wt) and that in the surrounding medium (mg kg^{-1} dry wt). The maximum BAF value was recorded in *M. indicus* at Chemaguri for Mn, Zn, and Hg. Consistent higher values were also pronounced for all the polychaetes for Cd, Zn, and Hg.

5.3.2.2 Trace Metals in Benthic Molluskan Shellfish

The capacity of representatives of benthic mollusks, especially gastropods and bivalves, to accumulate potentially toxic trace metals in their tissues from the ambient medium, is well-documented and proved to be excellent bioindicators of trace metal concentrations (Phillips, 1977). The present investigation also revealed the same potentiality in these two groups inhabiting in intertidal mudflat of Sundarban coastal regions. The studied species exhibited either organ-specific or species-specific pattern for accumulating specific metals (as evidenced from Tables 5.3 and 5.4) which was also endorsed by previous workers (Bryan and Langston 1992; Rajan and Kalyani 1990). Iron, Zn, and Cu were preferentially accumulated in both gastropods and bivalves as shown by other researchers (Rajendran et al. 1988; Pillai et al. 1986). A uniform pattern of distribution of Mn was recorded which might be accumulated from the food source (Eisler 1981). Maher et al. (2016) observed an overall variation in trace metal accumulation in the marine gastropod *Cellana tramoserica* (Holten, 1802) (Limpets family Nacellidae) between individuals and inherent variability due to genetic variability, resulting in positive skewing of population distributions. The findings inferred that the species could be efficiently used as a biomonitor of metal contamination in nearshore environments.

However, few metals (Co, Ni, Cd, and Pb) were below the spectrographic detection level for the studied species, excepting few cases. This depletion might be attributed to the respective concentration of these metals in seawater. Both Hg and As exhibited higher concentration especially in visceral mass and gill of *M. birmanica* (Table 5.3). This might be due to their bioavailability and feeding habits which results in biomagnifications. These values are higher than the maximum permissible limits (0.5 ppm for Hg and 1.0 ppm for As) in seafood for human consumption (FAO, 1983). Kesavan et al. (2013) observed the unique relations between sediments and accumulation of a suite of heavy metals (Cd, Co, Cu, Fe, Mg, Mn, Pb, Zn) in three molluskan shellfishes, namely, *Meretrix meretrix*, *Crassostrea madrasensis*, and *Cerithidea cingulata* from Uppanar estuary, south-east coast of India.

Considering the relative levels of each metal present, a concentration series for each tissue can be determined. High enrichment of Zn especially in mantle ($4700 \mu\text{g/g}$) and gill ($8200 \mu\text{g/g}$) of the oyster and in mantle ($8900 \mu\text{g/g}$) of the mussel was registered which might enter either by ingestion of particulate material (living and nonliving) suspended in the water or by uptake of dissolved metal from the water (Ayling 1978; Luoma 1983). Barnes (1968) studied the passage of sediments through the gills of lamellibranchiate mollusks and found that the sediment particles get trapped by secretions of the hypobranchial glands. The

Table 5.3 Heavy metal concentrations (mean values expressed in $\mu\text{g/g}$ dry wt) in various soft tissues from the mussel *M. birmanica* (size range 6.40 ± 0.5 cm) from Chemaguri mudflat, Sundarban wetland

	Fe	Zn	Cu	Mn	Co	Ni	Cd	Pb	Hg	As
RSD	1.50%	1.50%	1.20%	1.80%	1.50%	1.50%	1.50%	4.80%	4.50%	4.50%
DL ($\mu\text{g}/\text{ml}$)	0.10	0.018	0.077	0.052	0.12	0.14	0.028	0.19	0.00047	0.000095
		(1000 $\mu\text{g}/\text{g}^b$)	(70.0 $\mu\text{g}/\text{g}^b$)				(2.0 $\mu\text{g}/\text{g}^b$)	(2.5 $\mu\text{g}/\text{g}^b$)		
Tissue	Fe	Zn	Cu	Mn	Co	Ni	Cd	Pb	Hg	As
March	n									
	8									
Visceral mass ^a	3640	300	50	90	BDL	BDL	BDL	BDL	3.67	0.53
Podium	300	290	30	50	BDL	BDL	BDL	BDL	0.86	BDL
Siphon	2200	440	30	90	BDL	BDL	BDL	BDL	1.65	BDL
Mantle	4200	250	110	100	BDL	BDL	BDL	BDL	2.02	0.26
Gill	2400	920	60	80	BDL	BDL	BDL	BDL	0.81	BDL
Adductor muscle	1130	190	30	50	BDL	BDL	BDL	BDL	1.64	0.51
April	n									
	8									
Visceral mass ^a	2140	510	70	60	BDL	BDL	BDL	BDL	0.26	1.66
Podium	210	390	BDL	30	BDL	BDL	BDL	20	0.59	0.54
Siphon	3190	520	230	120	BDL	BDL	BDL	BDL	0.76	0.38
Mantle	5300	550	230	120	BDL	BDL	BDL	BDL	1.02	1.09
Gill	1630	1740	100	70	BDL	BDL	BDL	BDL	4.53	0.14
Adductor muscle	730	620	40	60	BDL	BDL	BDL	BDL	2.24	0.86
July	n									
	11									
Visceral mass ^a	2690	560	10	70	30	BDL	BDL	BDL	1.39	0.75
Podium	160	200	BDL	BDL	10	BDL	BDL	BDL	0.68	BDL
Siphon	2840	380	BDL	60	20	BDL	BDL	BDL	0.16	BDL
Mantle	3470	250	40	100	20	BDL	BDL	BDL	1.88	0.38
Gill	1470	500	10	20	20	BDL	BDL	BDL	2.42	0.08
Adductor muscle	800	1600	20	10	20	BDL	BDL	BDL	0.63	0.16

gills, being the vital organ in the filter-feeding, are continuously exposed to the ambient medium than the other body parts (Romeril 1971). The mucous covering of the gill and mantle might also have increased the adsorption of metals (Kumarguru and Ramamurthy 1978; Rajan and Kalyani 1990). Pringle et al. (1968) reported that mucous is complex sulfated mucopolysaccharide with exchange properties which facilitate a rapid exchange of metal ions across the cell membrane.

In general, a fair enrichment of Fe, Zn, Cu, and to some extent Mn was evident in the visceral mass for both the bivalves. The digestive diverticula present in the mass is actively involved in the digestion and absorption of food and excretion. Hence, it takes an active part in heavy metal accumulation. Lysosomes present in the cells also help in increasing metal concentration in the tissues. Adductor muscle in the bivalve showed a low concentration of metals in comparison with other organs which might be attributed to their least activity and nonsecretory function. The mussel may react to changes in metal levels by synthesizing metal-binding protein (Noel- Lambodt 1976) or by forming metal granules (Coombs and George 1978), thereby increasing the storage compartment. Accumulation of trace metals by mussel is influenced by salinity, temperature, and concentration of metals in water (Boyden and Romeril 1974).

Among essential trace metals, Zn and Cu seemed to be preferentially concentrated in *C. cucullata* (Table 5.4) which might be attributed to the capability of this filter-feeding bivalve to biomagnify these elements from seawater (Eisler, 1981). The gills and mantle showed a high uptake of these metals which is consistent with the findings of Korringa (1952) that positive polyvalent ions such as Al^{+++} , Cu^{+++} , Fe^{+++} , Zn^{+++} , and Mn^{+++} are concentrated by mucous sheets of oysters. Similar observation was also reported by Arul et al. (1990) and Brooks and Rumsby (1965). The present data demonstrates the potentiality of oysters as sentinel accumulators of heavy metals and can be successfully used for biomonitoring studies as emphasized by several workers (Hartwell et al. 1991).

The concentration of metals in the bivalves depends both on the level of the metal in the ambient medium and a variety of other ecological and biological factors. Forstner and Wittman (1981) pointed out that heavy metal concentration in oyster is a function of water quality, seasonal factors, temperature, salinity, diet, spawning, and individual variation. Ayling (1974) postulated that uptake of trace metal from sediment by oysters is related to both metal availability in the sediments and the animals' intake ability.

In gastropods, Fe, Zn, Cu, and Mn were accumulated with marked variations, and the values showed a species-specific pattern. The herbivorous winkle, *L. littorea*, registered a special affinity for accumulating Cu throughout the study period (maximum value 4300 $\mu\text{g/g}$), whereas *T. telescopium* and *C. cingulata* exhibited potentiality for Fe, Zn, and Mn, respectively. Substantial variation of these metals among the gastropods might be related to the nature of diet (Young 1975; Eisler 1981) and pollution (Phillips 1978). Recently, Ubrihien et al. (2017) established a link between metal accumulation at a contaminated site and reduced health of the intertidal gastropod *Bembicium nanum*, by measuring lysosomal destabilization, and thus could be recognized as bioindicator species.

Table 5.4 Heavy metal concentrations in soft tissues of a rock oyster, *C. cucullata* (4.12 ± 1.10 cm) (mean values expressed in µg/g dry wt)

	n	Fe	Zn	Cu	Mn	Co	Ni	Cd	Pb
April	12								
Visceral mass ^a		1000	700	270	20	BDL	BDL	BDL	BDL
Mantle		500	700	200	BDL	BDL	BDL	BDL	BDL
Gill		1000	2000	800	BDL	BDL	BDL	BDL	BDL
Ad. muscle		600	260	70	BDL	BDL	BDL	BDL	BDL
May	14								
Visceral mass ^a		1870	4700	480	50	10	BDL	30	BDL
Mantle		1040	4400	540	30	20	10	BDL	BDL
Gill		780	1000	340	20	10	BDL	20	BDL
Ad. muscle		710	1900	30	30	10	BDL	BDL	BDL
June	16								
Visceral mass ^a		1500	2300	510	80	BDL	BDL	60	20
Mantle		750	2300	490	30	BDL	BDL	40	20
Gill		1300	2200	570	20	BDL	BDL	40	BDL
Ad. muscle		180	530	60	BDL	BDL	BDL	20	20
July	14								
Visceral mass ^a		430	2500	610	40	BDL	BDL	30	BDL
Mantle		250	900	230	BDL	BDL	BDL	BDL	BDL
Gill		320	4500	770	40	BDL	BDL	30	BDL
Ad. muscle		270	2800	100	40	BDL	BDL	BDL	BDL
November	18								
Visceral mass ^a		440	2500	610	10	20	20	20	10
Mantle		750	3000	600	50	20	20	20	10
Gill		480	8200	560	20	30	20	20	20
Ad. muscle		570	1800	420	40	30	30	20	BDL
December	14								
Visceral mass ^a		330	3200	180	BDL	BDL	BDL	BDL	BDL
Mantle		220	2200	160	BDL	BDL	BDL	BDL	BDL
Gill		450	2600	540	BDL	BDL	BDL	BDL	BDL
Ad. muscle		210	200	240	BDL	BDL	BDL	BDL	BDL

n number of samples taken, *BDL* below detection limit

^aIncludes the gut contents

Elevated levels of Cu were attributable primarily to proximity to anthropogenic point sources as well as the copper storage granules (Martjoa et al. 1980). High values of Mn might be due to the composition of the muddy substrates (Graham 1972). Again, Boyden (1977) asserted that concentration of metals in gastropod mollusks is governed to some extent by the size of the organisms and mostly values decrease with increase in size or are dependent on size.

5.3.2.3 Factors Affecting Accumulation of Trace Metal in Biota

Trace metals get access into body tissues of marine organisms through variety of pathways, including seawater, particulate matter as well as ingestion of contaminated food. The nature of the contaminant itself, either inorganic or organic, is a crucial factor affecting tissue uptake, as well as the capacity of the organism to metabolize and excrete it. Accumulation strategy for a range of metals varies a wide range by each species for each metals, and these variations might be influenced by a number of intrinsic (e. g., size, age, and sex) and extrinsic (e. g., metal speciation and salinity) factors (Powell and White 1990). This strategy results from the net difference between rates of uptake and excretion of metal, as affected by change in body tissue. Relative rates of metal uptake and excretion are affected by features of the biology of the organisms, including the permeability of external surface, the nature of the food, and the efficiency of the osmoregulatory systems present (Rainbow 1990).

A set of environmental factors such as water current, renewal of water, pH, hardness, salinity, etc., also greatly affect the trace metal accumulation in marine biota. The greater metabolic rate of small organisms may partially account for the higher concentration of the essential elements like Zn and Cu (Williamson 1980). Body size and weight also play a significant role in metal bioaccumulation. In addition, uptake of metals and subsequent bioavailability are highly dependent on geochemical and biological factors. Among biological factors, there are major differences in bioaccumulation between species. Within a single species, accumulation can be a function of age, size, sex (especially for mollusks), genotype, phenotype, feeding activity, and reproductive state (Boening 1997).

5.4 Conclusion

The study provides important baseline data on the accumulation strategies of a diverse group of macrozoobenthos (MZ) inhabiting in Sundarban mudflat which can be used to assess future changes in contaminants for sustainable management of this stressed wetland. The diverse group of benthic MZ (polychaetes, gastropod, and bivalve mollusks) are found suitable for use as potential biomonitors and can be incorporated into the design of extensive pollution biomonitoring program in Sundarban coastal regions. These species possess all requisite characteristics to be considered a suitable biomonitor for metal contaminants in the environment, i.e., hardy, sessile, widespread, sufficient tissue mass, and a metal accumulator. The high degree of variability in metal/metalloid bioaccumulation of the MZ requires in-depth and long-term monitoring program. The coastal regions of India, including West Bengal, are in a stage of fast industrial and economic development; the increasing magnitude of diffusive sources includes street runoff, mining, dredging, as well as aeolian transport, and atmospheric deposition appears to have maintained high contamination levels. These processes affirm that metal exposure may continue to provide an alarming risk to this coastal environment. The study has pointed ample opportunity to investigate the complex interactions in muddy shore intertidal

food chains controlling metal trophic transfer in marine ecosystems. It is recommended for long-term assessments of changes in the patterns of physical forcing factors along with changes influx of potential contaminants on a wide array of edible species including fishes. Future research would benefit from large sample sizes and speciation of trace metals in the abiotic matrices as well as in the concerned species to better understand their bioavailability.

References

- Amiard JC, Triquet C, Berthet B, Metayer C (1987) Comparative study of the patterns of bioaccumulation of essential (Cu, Zn) and non-essential (Cd, Pb) trace metals in various estuarine and coastal organisms. *J Exp Mar Biol Ecol* 106:73–89
- Arul V, Rajan A, Kalyani M (1990) Dynamics of zinc concentration in *Katelyasia opima* (Gmelin) (Mollusca: Bivalvia) collected from Vellar estuary. *Proc Int Symp Mar Pollut* 277–286
- Ayling GM (1974) Uptake of cadmium, zinc, copper, lead and chromium in the Pacific oyster *Crassostrea gigas*. *Water Res* 8:729–738
- Ayling AL (1978) The relation of food availability and food preferences to the field diet of an echinoid *Evechinus chloroticus* (Valenciennes). *J Exp Biol Ecol* 33:223–235
- Barnes RD (1968) Invertebrate zoology. WB. Sanders Co, London, p 311
- Boening DW (1997) An evaluation of bivalves as biomonitors of heavy metals pollution in marine waters. *Environ Monit Assess* 55:459–470
- Boyd CR (1977) Effect of size upon metal content of shellfish. *J Mar Biol Assoc UK* 57:675–714
- Boyd CR, Romeril MG (1974) A trace metal problem in pond oyster culture. *Mar Pollut Bull* 5:74–78
- Brooks RR, Rumsby D (1965) Heavy metals in some New Zealand commercial sea fishes. *N Z J Mar Freshw Res* 8:155–166
- Bryan GW, Langston WJ (1992) Bioavailability, accumulation and effects of heavy metals in sediments with special reference to United Kingdom estuaries: a review. *Environ Pollut* 76:89–131
- Casado-Martinez MC, Smith BD, Luoma SN, Rainbow PS (2010) Bioaccumulation of arsenic from water and sediment by a deposit feeding polychaetes (*Arenicola marina*): a biodynamic modeling approach. *Aquat Toxicol* 98:34–43
- Coombs TL, George SG (1978) Mechanisms of immobilization and detoxication of metals in marine organisms. In: McLusky DS, Berry AJ (eds) *Physiology and behavior of marine organisms*. Pergamon Press, Oxford, pp 179–187
- Cousins RJ (1985) Absorption, transport and hepatic metabolism of copper and zinc special reference to metallothionein and ceruloplasmin. *Physiol Rev* 65:238–309
- Depledge MH, Rainbow PS (1990) Models of regulation and accumulation of trace metals in marine invertebrates. *Comp Biochem Physiol Comp Pharmacol* 97:1–7
- Diez S, Esbri JM, Tobias A, Higuera P, Martinez-Coronado A (2011) Determinants of exposure to mercury in hair from inhabitants of the largest mercury mine in the world. *Chemosphere* 84:571–577
- Eisler R (1981) Trace metal concentrations in marine organisms. Pergamon Press, New York, 687 pp
- Fauchald K (1977) The polychaete worms. Definitions and keys to the orders, families and genera, Science Series 28. Natural History Museum, Los Angeles
- Fernandes C, Nhas-Fernandes AF, Peixotoc F, Salgado MA (2007) Bioaccumulation of heavy metals in *Liza Saliens* from the Esmoriz-Paramos coastal Lagoon, Portugal. *Ecotoxicol Environ Saf* 66:426–431

- Fialkowski W, Rainbow PS (2016) What can the amphipod crustacean *Talitrus saltator* tell about variations in trace metal bioavailabilities in Baltic Sea coastal waters? *Estuar Coast Shelf Sci* (in press). <http://dx.doi.org/10.1016/j.ecss.2016.08.010>
- Folk RL, Ward WC (1957) Brazos River bar [Texas]; a study in the significance of grain size parameters. *Int J Sediment Res* 27:3–26
- Food and Agricultural Organization (1983) Compilation of legal limits for hazardous substances in fish and fishery products. Compiled by C.E Nauen, FAO, Rome
- Foster HD (2004) How HIV-1 causes AIDS: implications for prevention and treatment. *Med Hypotheses* 62:549–553
- Friedman GM, Sanders JE (1978) Principles of sedimentology. Wiley, New York. 792 p
- Forstner U, Wittmann GTW (1981) Metal pollution in the aquatic environment. Springer, Heidelberg. 486 pages
- Ganeev AA, Pogarev SE, Ryzhov VV, Sholupov SE, Dreval TV (1995) The new method for direct and express determination of mercury in oil, gas condensate, and biological samples. *Ecol Chem* 4:122–126
- Gibbs PE, Bryan GW, Ryan KP (1981) Copper accumulation by the polychaetes *Melinna palmata*: an antipredation mechanism? *J Mar Biol Assoc U K* 61:707–722
- Gibbs PE, Langston WJ, Burt GR, Pascoe PL (1983) *Tharyxmarioni* (Polychaeta): a remarkable accumulator of arsenic. *J Mar Biol Assoc U K* 63:313–325
- Golding LA, Borgmann U, Dixon DG (2013) Cadmium bioavailability to *Hyalella azteca* from a periphyton diet compared to an artificial diet and application of a biokinetic model. *Aquat Toxicol* 126:291–298
- Graham DL (1972) Trace metal levels in intertidal mollusks of California. *Veliger* 14:365–372
- Hartwell SI, Wright DA, Takacs R, Hocutt CH (1991) Relative respiration and feeding rates of Oyster and British water clam in variously contaminated wastes. *Mar Pollut Bull* 22(4):191–197
- Hutchings P (1998) Biodiversity and functioning of polychaetes in benthic sediments. *Biodivers Conserv* 7:1133–1145
- Kehrig HA, Malm O, Moreira I (1998) Mercury in widely consumed fish micropogoniasfumieri (Demarest 1823) from four main Brazilian estuaries. *Sci Total Environ* 213:263–271
- Kesavan K, Murugan A, Venkatesan V, Vijay Kumar BS (2013) Heavy metal accumulation in mollusks and sediment from Uppanar estuary, southeast coast of India. *Thalassas* 29(2):15–21
- Korringa P (1952) Recent advances in oyster biology. *Q Rev Biol* 27:266–308–339–365
- Kumaraguru AK, Ramamoorthi K (1978) Toxicity of copper to three estuarine bivalves. *Mar Environ Res* 1:43–48
- Liao JF (1990) The chemical properties of the mangrove *Solonchak* in the northeast part of Hainan Island. *Acta Scient Nat Univ Sunyatseni (Suppl)* 9:67–72
- Luoma SN (1983) Bioavailability of trace metals to aquatic organisms: a review. *Sci Total Environ* 28:1–22
- Mahler HR (1956) Nature and functions of metalloflavoproteins. *Adv Enzymol* 17:233
- Maher W, Maher N, Taylor A, Krikowa F, Ubrihien R, Mikac KM (2016) The use of the marine gastropod, *Cellana tramoserica*, as a biomonitor of metal contamination in near shore environments. *Environ Monit Assess* 188:391
- Markowski M, Kaliński A, Skwarska J et al (2013) Avian feathers as Bioindicators of the exposure to heavy metal contamination of food. *Bull Environ Contam Toxicol* 91:302–305
- Masih A, Taneja A, Singhvi R (2016) Exposure profiles of mercury in human hair at a terai belt of North India. *Environ Geochem Health* 38:145
- Memet V (2011) Assessment of heavy metal contamination in sediments of the Tigris River (Turkey) using pollution indices and multivariate statistical techniques. *J Hazard Mater* 195:355–364
- Moody JR, Lindstrom RM (1977) Selection and cleaning of plastic container for storage of trace element samples. *Analyt Chem* 49:2264–2267

- Mouneyrac C, Mastain O, Amiard JC, Amiard-Triquet C, Beaunier P, Jeantet AY, Smith BD, Rainbow PS (2003) Trace-metal detoxification and tolerance of the estuarine worm *Hediste diversicolor* chronically exposed in their environment. *Mar Biol* 143:731–744
- Olsgard F, Somerfield PJ (2000) Surrogates in marine benthic investigations— which taxonomic unit to target? *J Aquat Ecosys Stress Recovery* 7:25–42
- Phillips DJH (1977) The use of biological indicator organisms to monitor trace metal pollution in marine and estuarine environments - a review. *Environ Pollut* 13:281–317
- Phillips DJH (1978) The common mussel *Mytilus edulis* as an indicator of trace metals in Scandinavian waters. II. Lead, iron and manganese. *Mar Biol* 46:147–156
- Phillips DJH, Rainbow PS (1993) Biomonitoring of trace aquatic contaminants. *Els Appl Sci* 37:371
- Pillai VK, Ponniah AG, Valsala KK, Nair PVR (1986) Heavy metal load in a few bivalves from coastal waters of south India. In: Proceedings of the National Seminar on mussel watch, vol I. Cochin University of Science and Technology, Cochin, pp 93–104
- Powell MI, White KM (1990) Heavy metal accumulation by barnacles and its implications for their use as biological monitors. *Mar Environ Res* 30:91–118
- Pringle BH, Hissong DE, Katz EL, Mulawka ST (1968) Trace metal accumulation by estuarine mollusks. *J Sanit Eng Div* 94:455–575
- Rainbow PS (1990) Heavy metal levels in marine invertebrates, in heavy metals in the marine environments (Furness RW, Rainbow PS (eds)). CRC Press, Boca Raton, pp 67–79
- Rainbow PS (1995) Biomonitoring of heavy metal availability in the marine environment. *Mar Pollut Bull* 31(4–12):183–192
- Rajan A, Kalyani M (1990) *Donax cuneatus* (L.) (Mollusca: Bivalvia) – Indicator of copper in sandy shores of Porto Novo. *Proc Intl S ymp Mar Pollut* 26:1–275
- Rajendran N, Tagore J, Kasinathan R (1988) Heavy metal concentrations in oyster *Crassostrea madrasensis* (Preston) of Cuddalore backwaters, southeast coast of India. *Indian J Mar Sci* 17:174–175
- Rigét F, Dietz R, Born E, Sonne C, Hobson KA (2007) Temporal trends of mercury in marine biota of west and northwest Greenland. *Mar Pollut Bull* 54(1):72–80
- Romeril MG (1971) The uptake and distribution of Zn in oysters. *Mar Biol* 9:347–354
- Saha M, Sarkar SK, Bhattacharya B (2006) Interspecific variation in heavy metal body concentrations in biota of Sundarban mangrove wetland, northeast India. *Environ Int* 32:203–207
- Samuelson GM (2001) Polychaetes as indicators of environmental disturbance on subarctic tidal flats, Iqaluit, Baffin Island, Nunavut Territory. *Mar Pollut Bull* 42(9):733–741
- Sarkar SK, Franciscovic-Bilinski S, Bhattacharya A, Saha M, Bilinski H (2004) Levels of elements in the surficial estuarine sediments of the Hugli river, northeast India and their environmental implications. *Environ Int* 30:1089–1098
- Sarkar SK, Saha M, Takada H, Bhattacharya A, Mishra P, Bhattacharya B (2007) Water quality management in the lower stretch of the River Ganges, east coast of India: an approach through environmental education. *J Clean Prod* 15(16):1459–1467
- Sarkar SK, Binelli A, Riva C, Parolini M, Chatterjee M, Bhattacharya A, Bhattacharya BD, Jonathan MP (2012) Distribution and ecosystem risk assessment of polycyclic aromatic hydrocarbons. *Polycycl Aromat Compd* 32:1–26
- Sato M, Nakashima A (2003) A review of Asian *Hediste* species complex (Nereididae, Polychaeta) with descriptions of two new species and a redescription of *Hediste japonica* (Izuka, 1908). *Zool J Linn Soc* 137:403–445
- Sayed RE, Said M, Tharwat A, AbdAllah Mostafa MA, El-Shimy NA (2017) Efficiency of Polychaete *Nereis* (Neanthes) *Succinea* as Biomonitor for heavy metals pollution in the Red Sea Egypt. *Atmos Ocean Sci* 2(1):18–23
- Simpson RD (1979) Uptake and loss of zinc and lead by mussels (*Hytilus edulis*) and relationships with body weight and reproductive cycle. *Mar Pollut Bull* 10:74–78

- Ubrihien RP, Taylor AM, Maher WA (2017) Bioaccumulation, oxidative stress and cellular damage in the intertidal gastropod *Bembicium nanum* exposed to a metal contamination gradient. *Mar Freshw Res; CSIRO Publishing* 68(5):922–930
- Walkey A, Black TA (1934) An examination of the Dugtijaraff method for determining soil organic matter and proposed modification of the chronic and titration method. *Soil Sci* 37:23–38
- Wang WX, Fisher NS, Luoma SN (1996) Kinetic determination of trace element bioaccumulation in the *Mytilus edulis*. *Mar Ecol Prog* 140:91–113
- Williamson P (1980) Variables affecting body burdens of lead, zinc and cadmium in a roadside population of snail *Cepacahortinsis*. *Mull Oecol* 44:213–220
- Young ML (1975) The transfer of Zn^{65} and Fe^{59} along a *Ficus serratus* (Lo)-*Littorina obtusata* (L.) food chain nr. *Biol Ass UK* 55:587–610
- Zhou QX, Kong FX, Zhu L (2004) *Ecotoxicology: principles and methods*. Science Press, Beijing, pp 161–217

Geochemical Speciation and Risk Assessment of Trace Metals in Sediments of Sundarban Wetland

6

Abstract

The sequential extraction process is a unique tool in assessing the specific geochemical forms and binding states in the sediments and their ecological risk on the biotic species and thus confirming the environmental behavior of metals (mobility, pathways, and bioavailability). Different sequential extraction schemes have been used for the geochemical fractionation study of metals in sediments. Owing to the need for standardization and subsequent validation of extraction schemes for sediment analysis, the European Community Bureau of Reference (BCR) introduced in 1993 a new three-step sequential extraction. This BCR sequential extraction method analyzes different fractions of metals in the soil: acid extractable (water soluble, exchangeable, and bound to carbonates), reducible (bound to Fe and Mn oxides), oxidizable (bound to sulfides and organic matter), and residual. Water-soluble and exchangeable forms are considered readily mobile and available to biota, while metals that are incorporated into the crystalline lattices of clays appear relatively inactive. BCR procedure was followed in the present study to determine the concentrations of 11 trace metals (Al, As, Cd, Co, Cr, Cu, Fe, Mn, Ni, Pb, Zn) in different geochemical phases of sediments collected along the Hugli (Ganges) River Estuary and adjacent Sundarban mangrove wetland, India. This is considered as the most conventional method as it is simple, is applicable to all kinds of sediments, is low cost, and has easily understandable and comparable results. The chapter presents detailed information with respect to the origin, mobilization and transport, biological availability, and potential toxicity to various species.

Keywords

Sequential extraction • Chemical fractionation • Heavy metals • Sediment quality guidelines (SQGs) • Sediment • Hugli estuary • Sundarban

6.1 Introduction

Heavy metal contamination in the coastal regions has become a serious problem especially in Asian countries as they undergo accelerated development of urbanization and industrialization. In India, toxic metal/metalloid pollution in marine and riverine ecosystem is steadily increasing due to uncontrolled and untreated disposal of industrial and municipal wastewaters. Heavy metals are a great concern due to their persistence in the aquatic system, abundance, and subsequent accumulation of high level of toxicity. Trace elements are present in sediment in various ways such as ion exchange, adsorption, precipitation, and complexation and hence not permanently fixed by sediment. Natural and anthropogenic activities have the ability to cause changes in certain environment conditions, such as salinity, pH, redox potential, or organic ligand concentrations. These can remobilize contaminated sediments releasing the elements from sediments and sediment pore water to the water column and cause contamination of surrounding waters. Daily tidal currents, wind energies, and storms in coastal and estuarine systems can cause periodical remobilization of surface sediments (Calmano et al. 1993).

Information on the total concentration of heavy metals is the most fundamental way to get an overall sediment quality assessment and thus does not provide sound basic information for determination of environmental health risk, strongly related to their specific chemical forms and binding state (Filgueiras et al. 2002, 2004; Islam et al. 2015). Generally, heavy metals exist in sediments in different chemical forms, which exhibit different physicochemical behaviors which determine the mobility, chemical interaction, biological availabilities, and potential toxicity (He et al. 2009; Keshavarzi et al. 2014). Hence, metal fractionation which occurred in different geochemical forms is of crucial importance which have distinct bioavailability, mobility, and reactivity in sediments. Heavy metals interact with sediment fractions and exhibit different binding mechanisms with carbonates, Fe–Mn oxides, and organic matter (Gao and Li 2012). Determination of the geochemical fractionation of trace metals in sediment matrices is crucial to ascertain their toxicity, mobility, and actual sources, either natural or anthropogenic. Accumulation of trace metals in the resistant fraction indicates their origin from natural sources, whereas nonresistant fraction indicates their origin from anthropogenic sources (Liu et al. 2015). The sequential extraction is an effective approach to get the precise information about the strength and ways of metal association pattern within the different binding phases of the sediments.

In addition, activities such as dredging and drilling result in major sediment disturbances, leading to changes in chemical properties of sediment (Eggleton and Thomas 2004). Sequential extraction (Tessier et al. 1979) can provide information about the identification of the main binding sites, the strength of element binding to the particulates, and the phase associations of trace elements in sediment. Following this basic scheme, some modified procedures with different sequences of reagents or operational conditions have been developed gradually over years (Borovec et al. 1993; Campanella et al. 1995; Zdenek 1996; Gomez Ariza et al. 2000). Considering the diversity of procedures and the lack of uniformity in

different protocols, a European Community Bureau of Reference (BCR, now the European Community's Standards, Measurement, and Testing Program) method was proposed (Ure et al. 1993) and was applied by a large group of researchers (Ho and Evans 1997; Lopez-Sanchez et al. 1998; Usero et al. 1998; Martin et al. 1998; Agnieszka and Wieslaw 2002). In this study, we followed the sequential extraction procedure proposed by the European Union's Standards, Measurements, and Testing Program (Sahuquillo et al. 1999).

The chapter aims to assess the chemical fractionation of 11 trace metals (Al, As, Cd, Co, Cr, Cu, Fe, Mn, Ni, Pb, and Zn) in surface sediments collected from intertidal regions of Sundarban wetland along with the adjacent Hugli River Estuary. The potential toxicity due to trace element bioavailability has been evaluated by employing sediment quality guidelines (SQGs). Numerical SQGs have been demonstrated as a useful tool for assessing the quality of sediments in different aquatic bodies and identifying the chemical concentrations resulting in adverse effects on sediment-dwelling organisms (Long et al. 2006). The most recent development in sediment quality guidelines is where the effect-level concentrations from several guidelines of similar narrative intent are combined through averaging to yield consensus-based lower and upper effect values for contaminants of concern. The consensus-based values for individual contaminants provide an accurate basis for predicting the presence or absence of toxicity (MacDonald et al. 2000).

Recently, José Moacir de Carvalho Araújo Júnior et al. (2016) evaluated the burrowing activity of the crab *Ucides cordatus* and its effects on Fe, Cu, and Zn fractionation, bioavailability, and bioaccumulation in a semiarid mangrove area (Ceará state, NE-Brazil). They have reported that the burrowing activity and seasonal variation affect the biogeochemical conditions of mangrove soils increasing metal bioavailability and bioaccumulation. The crab burrows favor the entrance of oxygen into the soil, oxidizing the pyrite and forming poorly crystalline Fe minerals, increasing the risks of biocontamination.

The Hugli (the lower stretch of Ganges River) River Estuary (21°00'–22°30'N and 88°00'–89°28'E) is a tropical and turbid environment. This represents a dynamic and biologically productive system, jointly influenced by geomorphological, physicochemical, and biological processes. It is a densely populated, low-lying, and highly vulnerable coastal environment where over-siltation creates a huge problem, especially in the context of primary productivity. The deltaic tidal stretch receives heavy discharge of industrial effluents to the tune of 430 million liter per day from multifarious industries situated on the banks of Hugli River (Sen et al. 1994). Tide is semidiurnal and belongs to macrotidal regime (tidal range up to 6 m; Sarkar et al. 2002) producing a strong flushing of the coastal areas, effectively dispersing pollutants. Hugli River collects and transports natural weathering products as well as potentially harmful elements derived from anthropogenic sources. It has been estimated that at Kolkata, the Ganges annually supplies 411×10^6 t of total load to the Hugli estuary (Sarkar et al. 2004). The system is subject to human disturbances such as eutrophication, land reclamation, overfishing, and overexploitation of coastal resources. The estuary has become

vulnerable to chemical pollutants such as heavy metals, organochlorine pesticides, petroleum-derived hydrocarbons, chlorinated hydrocarbons, etc., which might have changed the estuary's geochemistry and affected the quality of the local coastal environment (Sarkar et al. 2004; Saha et al. 2006).

Previous studies on the pollution status of Sundarban wetland along with the adjacent Hugli estuary have revealed an elevated concentrations of total trace elements (Cu and Zn) and metalloid (As) in surface and core sediments exceeding the SQG values called effects range low (ERL) implying occasional or frequent biological effects (Sarkar et al. 2004; Chatterjee et al. 2007, 2009). Hence, the chapter has taken utmost care to identify and evaluate the mobility and nature of toxicity of selective trace elements in sediment samples.

6.2 Significance of Sequential Extractions for Metal Speciation

Geochemical fractionation approach to the chemical speciation has provided a useful tool and opens a new dimension in assessing the potential mobility/bioavailability of heavy metals and metalloids in soils/sediments. Sequential extraction is an important and ubiquitous method that provides information about the strength of metal binding to particulate and the phase associations of metals in solid matrix (Hass and Fine 2010; Sutherland 2010; Tessier et al. 1979). The process provides more or less detailed information concerning the origin, mode of occurrence, biological and physicochemical availabilities, and mobilization and transport of heavy metals. The procedure stimulates the mobilization and retention of these species in the natural environment using changes in environmental condition such as pH, redox potential, and degradation of organic matter. A series of reagents is applied to the sample, increasing the strength of the extraction at each step, in order to dissolve the trace metal present in different sediment phases. The extractants are inert electrolytes, weak acids, reducing agents, oxidizing agents, and strong mineral acids.

Sequential extraction, as described above, involves the use of a series of chemical extractants that selectively dissolve the different chemical constituents of sediment materials, by adopting different techniques to analyze the geochemical fractions (Schramel et al. 2000; Kaasalainen and Yli-Halla 2003; Anju and Banerjee 2010). Among such techniques, the most employed technique is the European Community Bureau of Reference (BCR). This is a three-step sequential extraction which harmonizes various sequential extraction processes, considering varying numbers of steps, types of reagents, and extraction condition (Cuong and Obbard 2006; Yan et al. 2010; Oyeyiola et al. 2011; Moore et al. 2015), widely used in numerous types of solid samples, including freshwater sediments, saltwater sediments, soil, sewage sludge, and particulate matter (Filgueiras et al. 2002; Gleyzes et al. 2002; Hass and Fine 2010; Sutherland 2010).

Different techniques related to sequential extraction facilitate fractionation, and the theory behind the process is that the most mobile or exchangeable metals are

removed in the first fraction, following successive geochemical stages in order of decreasing of mobility which are described as follows:

1. *Acid-soluble phase*: This fraction is also known as nonspecifically adsorbed fraction, made up of exchangeable metals and others bound to carbonates which can be released into the water column by the action of cations (K, Ca). It is susceptible to changes in pH and forms the most labile bond to the soil/sediment and, therefore, the most dangerous for the environment. The carbonate-bound fraction is susceptible to changes in pH; an acid solution is used second. Metals bound to Fe and Mn oxides are particularly susceptible to anoxic (reducing) conditions, so a solution capable of dissolving insoluble sulfide salts is used third.
2. *Reducible phase*: The metals bound to Fe and Mn oxides are particularly susceptible to anoxic (reducing) conditions and thus can be released if the sediment changes from the toxic to the anoxic state, due to activity of microorganisms (bacteria) in the soils/sediments.
3. *Oxidizable phase*: This fraction relates to metal associated to organic matter and sulfides, which can be released under oxidizing conditions, due to resuspended particles (by dredging, strong currents, flooding, tides, etc.) coming into contact with oxygen-rich water. To remove metals bound in the organic phase, the organic material must be oxidized using reagents, such as hydrogen peroxide with ammonium acetate readsorption.
4. *Residual phase*: Typically metals of anthropogenic inputs tend to reside in the first three fractions, and metals found in the residual fraction are of natural occurrence. The residual fraction is lithogenous and inert (non-bioavailable) and hardest to remove and requires the use of strong acids (such as nitric acid, hydrochloric acid, or mixture such as aqua regia) to break down the crystal structures of primary and secondary minerals.

The heavy metals in the soils and sediments are bound to different fractions with different strengths; the value can therefore give a clear indication of soil and sediment reactivity, which in turn assesses the risk connected with the presence of heavy metals in a terrestrial or aquatic environment. The rationale of the sequential extraction procedure is that each successive reagent dissolves a different component, which can contain heavy metals within their crystalline structures.

6.2.1 Drawback of Sequential Extraction Technique

(a) Depending on pH, Eh, temperature, and duration of reaction time, there are possibilities of back extraction and overassessment of the concerned trace element, and (b) the technique is strongly matrix dependent; hence, the minerals present in different sediment types may also affect the process (river/pond sediments vs. deep-sea sediments).

6.3 Materials and Methods

6.3.1 Sample Collection and Sediment Quality Analysis

Nine monitoring stations, namely, Barrackpore, Dakshineswar, Uluberia, Babughat, Budge Budge, Diamond Harbour, Frazergunj, Gangasagar, and Haribhanga have been chosen considering the existence of typical sediment dispersal patterns along the drainage network systems (Fig. 6.1). Stations are representative of the Ganges River basin of different environmental stresses and geomorphic–hydrodynamic conditions; moreover, they are located at different distances from the sea (Bay of Bengal) and are exposed to a variable level of trace element contamination. Six sampling sites have been chosen along the lower stretch of Hugli estuary, while three sampling sites were chosen in the marine coastal area overlooking the Hugli estuary. During sample collection, a manual global positioning system (GPS) was used to fix the coordinates of the study sites. All sampling sites together with the main stresses to which they are subjected are reported in Table 6.1.

Sediment samples weighing ~10 g were randomly collected from the top 3–5 cm of the surface at each sampling site during low tide using a grab sampler, pooled and thoroughly mixed. Samplings were at least triplicated to ensure the representativeness of the samples. Immediately after collection, the samples were placed in sterilized plastic bags in the ice box and transported to the laboratory. Samples were oven-dried at 50 °C to a constant weight, most gently disaggregated, transferred into pre-cleaned inert polypropylene bags, and stored in deep freeze prior to analyses. Each sample was divided into two aliquots: one unsieved (for the determination of sediment quality parameters) and the other sieved through 63- μm metallic sieves (for elemental analyses).

6.3.2 Analytical Procedure

Organic carbon content was determined following a rapid titration method (Walkey and Black 1934) and pH with the help of a deluxe pH meter (model no. 101E) using combination glass electrode manufactured by M.S. Electronics (India) Pvt. Ltd. Mechanical analyses of sediment were done by sieving in a Ro-Tap Shaker manufactured by W.S. Tyler Company, Cleveland, Ohio.

Sediment samples were acid digested in polytetrafluoroethylene vessels with HCl and HNO₃ (3:1) and HF neutralized with H₃BO₃ in a 650-W microwave oven. The digested samples were filtered, transferred to polyethylene containers, and stored at +4 °C until further analyses. All reagents were Suprapur® grade (Merck). Reagent blank was processed with the samples and did not show any significant contamination. Accuracy of the procedure was checked using two different certified reference materials (CRM): MESS-2 and PACS-2. These are marine sediments certified by the National Research Council of Canada for the element content. The MESS-2 (characterized by element concentrations more

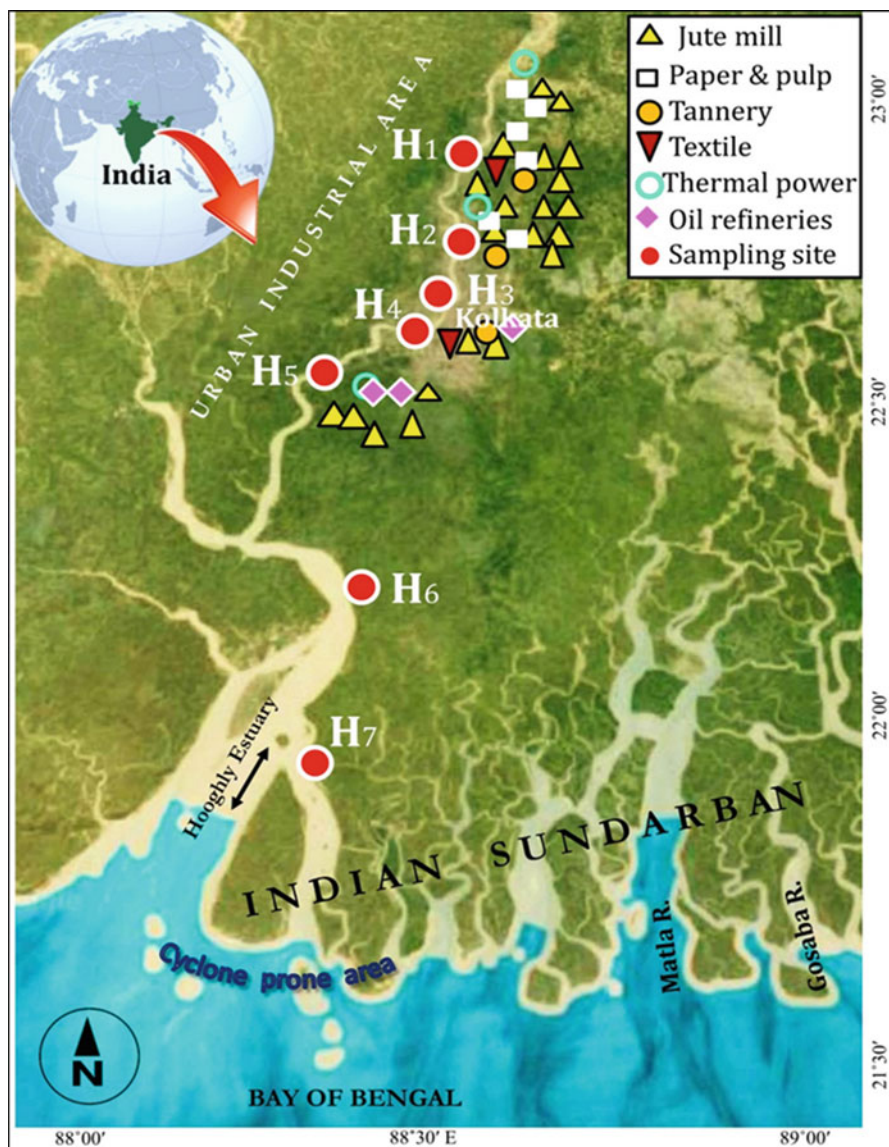

Fig. 6.1 Map showing location of nine sampling stations along with the position of multifarious industries along the banks of Hooghly estuary (H₁, Barrackpore; H₂, Dakshineswar; H₃, Uluberia; H₄, Babughat; H₅, Budge budge; H₆, Diamond Harbour; H₇, Lot8/Kakdwip)

similar than PACS-2 to those measured in the analyzed samples) recovery ranged between 91% and 116% for all the elements.

Sequential extraction is carried out based on the method previously used by Tessier et al. (1979) with subsequent upgradations made according to the BCR. The

Table 6.1 Nature of diverse human-induced stresses of the nine monitoring sites covering Sundarban wetland and adjacent coastal regions

Sampling Site	Latitude (°N)	Human-induced stresses
	Longitude (°E)	
Barrackpore	22°43' 16" N	Industrial effluents, domestic sewage disposal, boating, bathing, immersion ghat of idols
	88°21' 20" E	
Dakshineswar	22°39' 17" N	Industrial and domestic effluents, boating, bathing
	88°12' 25" E	
Uluberia	22°33' 53" N	Domestic and industrial effluents
	88°20' 19" E	
Babughat	22°30' 10" N	Power plant discharges, domestic sewage, boating
	88°11' 48" E	
Budge Budge	22°28' 06" N	Domestic and industrial effluents, bathing, boating, immersion ghat of idols
	88°06' 54" E	
Diamond Harbour	22°11' 14" N	Boating, recreational activities, bathing, fishing, jetties for fishing trawlers
	88°11' 15" E	
Frazergunj	21°34' 44" N	Tourist activities, ferry services, fishing
	88°15' 03" E	
Gangasagar	21°38' 15" N	Boating, tourist activities, dredging, fishing, agricultural, domestic, and aquacultural practices
	88°03' 53" E	
Haribhanga	21°34' 20" N	Boating, fishing, and ferrying
	88°01' 25" E	

procedure is composed of the following three phases: (1) exchangeable and bound to carbonate (phase I), (2) bound to Fe and Mn oxides and hydroxides (phase 2), and (3) bound to organic matter and sulfides (phase 3). The first phase (phase 1) is extracted with 0.11 M acetic acid, while phase 2 is done with 0.5 M hydroxylamine hydrochloride, adjusted to pH 2 with nitric acid (65%). The final phase 3 is extracted with 8.8 M hydrogen peroxide (stabilized at a pH included between 2 and 3), treated at 80 °C in a microwave oven using a program consisting of a 30-min ramp and a 60-min hold at 50% power in pressure- and temperature-controlled conditions (80 psi and 85 °C), and 2 M ammonium acetate adjusted to pH 2 with nitric acid (65%). Each extraction was carried out overnight (16 h) at room temperature. All the reagents employed were Tracepur[®] grade (Merck Eurolab, Italy). After each extraction, the samples were separated from the aqueous phase by centrifuging at 4000 rpm for 15 min. The sediments were washed with Milli-Q water and centrifuged again and later on added to supernatants.

The element content of the residual or inert phase was obtained from the difference between the total content and the sum of three phases as previously referred. The residual phase of the element content is considered the difference between the total metal concentration and sum of three phases (phase 1 + phase 2 + phase 3), as described by Ianni et al. (2000, 2001), Ramirez et al. (2005), and Mester et al. (1998). Accuracy of the analysis was checked with BCR-701 (SM&T). The recovery rates for trace elements in the standard reference material ranged

between 77% and 118%. Inductively coupled plasma atomic emission spectrometer (ICP- AES) Vista Pro (Varian) was used for analyzing the 11 trace metals concentration, whereas electrothermal atomization atomic absorption spectrometry was used for Cd estimation.

6.3.3 Statistical Analyses

Principal component analysis (PCA) is a multivariate statistical technique that deals with the internal structure of matrices. This is a widely used valuable ordination method in ecological studies, breaking down a resemblance matrix into a set of orthogonal components. The PC scores provide information on all of the studied variables combined into a single number, with the loadings indicating the relative contribution of each variable to that score (Farnham et al. 2003). Hierarchical clustering or hierarchical cluster analysis (HCA) is a widely used data analysis tool that characterizes similarities among samples *and* distance between two *clusters* to be the maximum distance between their individual components. The sample similarities are represented on two dimensional diagrams, known as dendrograms (Ragno et al. 2007). Statistical analyses were carried out with the help of software STATISTICA (StatSoft, Inc. 2001).

6.4 Results and Discussion

6.4.1 Sediment Quality Characteristics

The values of general sediment properties such as pH, organic carbon (%), and sediment textures (sand, silt, and clay) in surface sediments of the nine sampling sites have been presented in Table 6.2. The sediment quality characteristics are characterized by slightly basic pH (7.50–8.36) with maximum values recorded in the stations closest to the sea and minimum in station Frezergunj. These were different from the low pH values in most of the mangrove swamps in Hong Kong (Tam and Wong 2000), where sediments were not frequently flooded by the tide and become acidic in reducible conditions. Values of organic carbon exhibited narrow range (0.22% at station Gangasagar to 1.02% at Dakshineswar), and prevalent values are significantly low while compared to the existing values encountered in other coastal regions, such as Gulf of Mannar (Jonathan and Ram Mohan 2003), Cochin (Sunil Kumar 1996), and Muthupet mangroves (Janaki-Raman et al. 2007). The observed low organic carbon values might be linked to the following reasons: (1) poor absorbability of organics on negatively charged quartz grains, which predominate in sediments in this estuarine environment (Sarkar et al. 2004), and (2) the constant flushing activity by tides along with the impact of waves which can support the low values in the sediments. Regarding textural properties, the sediment samples revealed variable admixture of sand, silt, and clay. The finer clay fractions were dominant in low-energy regions of suspensional deposits. In contrast, the

Table 6.2 Sediment quality characteristics of the nine sampling sites covering Sundarban wetland and adjacent coastal regions

Sampling sites	Salinity	pH	Organic carbon (%)	Sediment texture		
				Sand (%)	Silt (%)	Clay (%)
Barrackpore	<0.5	7.86	0.35	4	87.1	8.9
Dakshineswar	<0.5	7.8	1.02	1	76.5	22.5
Uluberia	0–1	7.9	0.91	16.7	69.6	13.7
Babughat	0–2.5	7.6	0.74	18.25	47.42	34.33
Budge Budge	<0.5	7.9	0.52	2.24	41.97	55.79
Diamond Harbour	0–5.6	8.36	0.56	3.15	41.13	55.71
Frazergunj	30–34.3	7.5	0.36	98.02	0.18	0
Gangasagar	32–35	8.14	0.22	32.85	58.45	8.7
Haribhanga	35	8.1	0.46	39.3	44.25	16.45

other two size fractions, silt and sand, dominate those regions where the energy level is high. Absolute dominance of sand (~98%) was recorded from station Frezergunj, but sediments from four study sites, namely, Barrackpore, Dakshineswar, Uluberia, and Gangasagar, contain higher percentage of silt (>50%). A variable admixture of sand, silt, and clay exists in other sampling sites which reflects to a variable degree of erosion and deposition, differences of tidal mixing, and flocculation and deflocculation processes.

6.4.2 Metals Present in Total Concentration in Sediments

The concentrations of the total elements varied within a very narrow range and were compared to the data obtained from other Indian coastal regions (Subramanian and Mohanachandran 1990; Chatterjee et al. 2009). Similar trace element concentrations were also reported by Datta and Subramanian (1998) throughout the Bengal Basin, where anthropogenic perturbation is low and river channel may receive a several centimeter-thick sediment layer in a single event during peak flow, preventing to bear the signature of an accumulation of trace elements. The total concentrations of trace elements in the sediments were in the following decreasing order: Al > Fe > Mn > Zn > Cr > Ni > Cu > Pb > Co > As > Cd. The maximum concentrations for As, Fe, Mn, and Ni were encountered at station Haribhanga, while lowest element concentrations were found at station Uluberia. The high concentrations of Cd and Pb obtained at station Babughat, adjacent to the megacity Calcutta (about 4.5 million residents, but about 14.2 million including suburbs), might be attributed to anthropogenic input from vehicular traffic, industrial activities, and discharge of untreated sewage. Very low (close to the detection limit) Cd concentration was found in other sampling stations (Table 6.3).

Table 6.3 Concentration of trace metals in sediments (expressed in $\mu\text{g g}^{-1}$ dry weight) of nine sampling sites covering Sundarban wetland and adjacent coastal regions

	Al	As	Cd	Co	Cr	Cu	Fe	Mn	Ni	Pb	Zn
Barrackpore	70,289	8.81	0.165	13.02	67.63	27.83	37,737	591	31.93	20.44	86.55
Dakshineswar	70,879	8.44	0.452	13.99	74.76	36.83	39,405	625	34.17	22.33	90.72
Uluberia	62,044	6.41	0.220	12.06	58.24	21.11	33,428	597	27.49	17.00	64.05
Babughat	72,613	8.49	0.492	14.88	76.84	27.85	40,303	726	35.03	19.55	80.44
Budge Budge	72,134	8.65	1.792	14.53	73.52	32.33	40,070	712	35.04	33.18	83.14
Diamond Harbour	64,325	6.79	0.106	12.00	64.76	31.99	34,273	613	31.30	17.86	69.58
Frazergunj	77,529	7.77	0.044	14.00	75.12	28.35	40,084	389	38.06	20.48	74.37
Gangasagar	68,146	8.08	0.027	12.69	62.51	22.17	36,786	511	34.27	19.73	61.38
Haribhanga	72,666	9.40	0.044	14.06	74.22	36.60	40,838	785	40.09	22.92	74.88

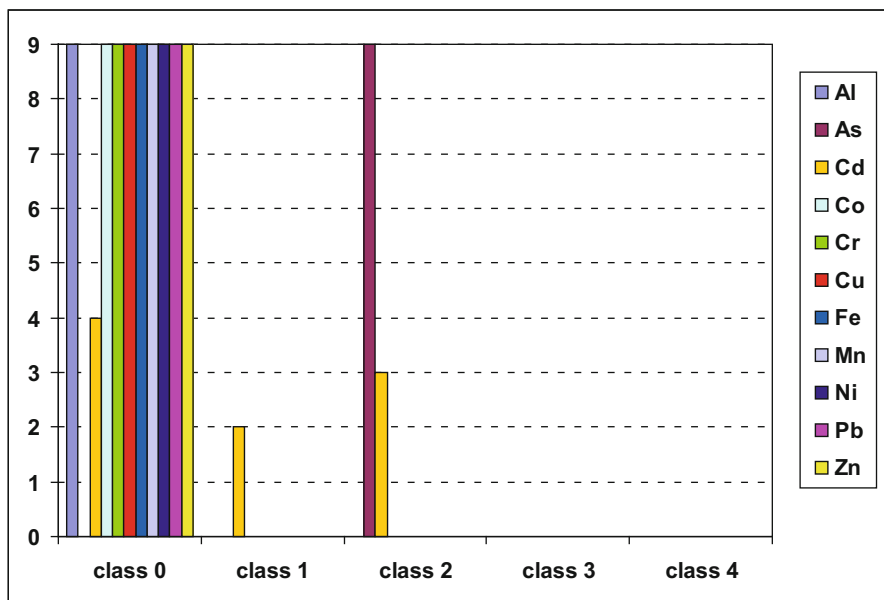

Fig. 6.2 Graph showing the Geoaccumulation index (I_{geo}) calculated for the 11 trace metals in the nine monitoring sites

6.4.3 Geoaccumulation Index (I_{geo})

The geoaccumulation index (I_{geo}) of Müller (1979) has been calculated for the analyzed elements, by comparing current concentrations with preindustrial levels, in order to estimate the metal contamination in sediments. The equation used for the calculation of I_{geo} is $\log_2 (C_n/1.5 B_n)$, where C_n is the measured content of element “n” and B_n the element’s content in “average shale” (Salomon and Förstner 1984). As shown in Fig. 6.2, the I_{geo} values of Al, Co, Cr, Cu, Fe, Mn, Ni, Pb, and Zn were below 0 ($I_{geo} \leq 0$) indicating that the area is not contaminated for these elements. Unlike the Hugli River, in other rivers of the Bengal Basin, such as Meghna and Brahmaputra, Cr exhibits higher I_{geo} values with respect to the other elements (Datta and Subramanian 1998). For Cd two stations exhibited “uncontaminated to moderately contaminated” status, while three stations revealed class 2 level of contamination indicating “moderate contamination” of the sediments. Arsenic exhibited “moderate contamination” ($1 < I_{geo} < 2$) at all the sampling sites. In this area, As contamination was already observed in previous studies, and it is probably due to groundwater contamination (Dowling et al. 2002). This contamination can have natural origin, such as coal seams in Rajmahal Basin and arsenic mineral in mineral rocks in the upper reaches of the Ganges River system. The highly reducing nature of groundwater would reduce As, causing its possible desorption (Acharyya et al. 2000).

6.4.4 Comparison with Sediment Quality Guidelines

Total and sequential extraction of trace metals as observed in the present investigation is compared with consensus-based SQGs values (as depicted in Table 6.4). The values are related to TEC (concentration below which harmful effects on benthic organisms were not expected) and PEC (concentration above which harmful effects on benthic organisms expected to occur frequently). Again, effects range-low, ERL (concentrations below which adverse biological effects are recorded in less than 10% of studies), and effects range-medium, ERM (concentrations above which effects are more frequently observed in more than 75% of studies), values are also taken into consideration. The concentrations of both Pb and Zn at all the studied stations were lower than both TEC and ERL, while comparing their respective values. In the total as well as labile fraction, concentration of Cd at the site Babughat was observed to be greater than both ERL and TEC but lower than PEC and ERM values. This denotes negative impacts on benthos due to the large amount of trace metal bound to the most labile phase of the sediment. Again, concentrations of total Cu at three sites (Dakshineswar, Budge Budge, and Haribhanga) exceeded higher than TEC but lower than PEC prescribed values. However, Cu concentrations at Dakshineswar and Haribhanga were higher than the prescribed ERL levels. Arsenic concentrations are higher than ERL value at 55.5% of the stations but lower than TEC value. Since more than 50% of total arsenic is not observed in the residue, attention should be given to a change in the environment conditions which could induce a release of this metalloid from the sediments. Concentrations of Ni and Cr are higher than TEC (Ni is also higher than ERL) but lower than PEC (and ERM in the case of Ni) in all the stations. Nevertheless, more than 70% of Ni as well as 90% of Cr are present in the residual fractions; hence, the adverse effects of these hazardous metals are not expected.

Mean sediment quality guidelines quotients (mSQGQ) have been developed for assessing the potential effects of contaminant mixtures in sediments (Long et al. 2006): they are determined by calculating the arithmetic mean of the quotients derived by dividing the concentrations of chemicals in sediments by their respective SQGs. The probability of observing sediment toxicity can be estimated by comparing the mSQGQ in a sample to previously published probability tables. It is important to keep in mind that mSQGs cannot be used to accurately predict the uptake and bioaccumulation of sediment-bound chemicals by fish, wildlife, and humans, even if there is considerable evidence that this assessment tool can be predictive of the presence or absence of toxic effects (Long et al. 2006). In order to evaluate the possible biological effects of the coupled toxicity of As, Cd, Cr, Cu, Ni, Pb, and Zn in the sediments, the mSQGQ was calculated considering ERM as sediment quality guidelines (Table 6.5). The mean quotient values ranged from 0.16 (at Uluberia) to 0.24 (at Babughat). Using PEC values instead of ERM, the mean SQGQ ranges from 0.25 in station Uluberia to 0.38 in station Babughat (Table 6.5).

SQGs are calculated for seven studied trace metals comparing ERM as sediment quality guidelines (Table 6.5). The mean quotient values range from 0.16 (at Uluberia) to 0.24 (at Babughat). Using PEC values instead of ERM, the mean

Table 6.4 Sediment quality guideline concentrations with respect to total and labile fraction of the trace metals in the analyzed samples (expressed in microgram per gram of dry weight)

Elements	Fraction	$S_i < \text{TEC}$	TEC ($\mu\text{g}/\text{g-dw}$)	$\text{TEC} < S_i < \text{PEC}$	PEC ($\mu\text{g}/\text{g-dw}$)	$S_i < \text{ERL}$	ERL ($\mu\text{g}/\text{g-dw}$)	$\text{ERL} < S_i < \text{ERM}$	ERM ($\mu\text{g}/\text{g-dw}$)
As	Total	All	9.79	None	33	Uluberia, Diamond Harbour, Frazergunj, Gangasagar	8.2	Barrackpore, Dakshineswar, Babughat, Uluberia, Haribhanga	70
	Labile	All		None		All		None	
Cd	Total	Barrackpore, Dakshineswar, Babughat, Uluberia, Diamond Harbour, Frazergunj, Gangasagar, Haribhanga	0.99	Budge Budge	4.98	Barrackpore, Dakshineswar, Babughat, Uluberia, Diamond Harbour, Frazergunj, Gangasagar, Haribhanga	1.2	Budge Budge	9.6
	Labile	Barrackpore, Dakshineswar, Babughat, Budge Budge, Diamond Harbour, Frazergunj		Budge Budge		Budge Budge, Uluberia, Diamond Harbour, Frazergunj		Budge Budge	

Cr	Total	None	43.4	All	111	All	81	None	370
	Labile	All		None		All		None	
Cu	Total	Barrackpore, Babughat, Uluberia, Frazergunj, Gangasagar	31.6	Dakshineswar, Budge Budge, Diamond Harbour, Haribhanga	149	Barrackpore, Budge Budge, Babughat, Uluberia, Diamond Harbour, Frazergunj, Gangasagar	34	Dakshineswar, Haribhanga	270
	Labile	All		None		All		None	
Ni	Total	None	22.7	All	48.6	None	20.9	All	51.6
	Labile	All		None		All		None	
Pb	Total	All	35.8	None	128	All	46.7	None	218
	Labile	All		None		All		None	
Zn	Total	All	121	None	459	All	150	None	410
	Labile	All		None		All		None	

Table 6.5 Mean sediment quality guideline quotients calculated for the nine sampling stations using PEC and ERM as SQGs

Sites	SQGG _{PEC}	SQGG _{ERM}
Barrackpore	0.30	0.19
Dakshineswar	0.33	0.21
Uluberia	0.25	0.16
Babughat	0.33	0.21
Budge Budge	0.38	0.24
Diamond Harbour	0.28	0.18
Frazergunj	0.32	0.21
Gangasagar	0.28	0.18
Haribhanga	0.34	0.22

SQGG ranges from 0.25 (at Uluberia) to 0.38 (at Babughat) (Table 6.5). In a preliminary survey at Biscayne Bay (port of Miami and the adjoining saltwater reaches of the lower Miami River, FL, USA), it is revealed that the average amphipod survival (*Ampelisca abdita*) decreased slightly from the least contaminated (ERM_Q <0.03) to the intermediate category (ERM_Q included in 0.03–0.2 range) and then decreased greatly in the most contaminated sediments (ERM_Q included in 0.2–2 range). Hence it is presumed a low toxicity of sediments for the nine sampling sites of the present work for benthos. It is important to note that the benthic response to contaminants covaried among stations with both the mean ERM quotients and the effect of natural factors, such as the sediment texture, TOC, and salinity (Long et al. 2006).

6.4.5 Speciation Patterns of Metals/Metalloids

The potential ecotoxicological relevance of trace metals in sediments is mainly concerned to their total content as well as their chemical speciation or geochemical fractionation. Various physicochemical processes control the availability and the fate of elements in sediment (Palleyi et al. 2015). The results of chemical partitioning of the studied trace metals (Al, As, Cd, Co, Cr, Cu, Fe, Mn, Ni, Pb, and Zn) are presented in Fig. 6.3. Fractionation results showed that there are two groups of elements with similar chemical partitioning: group 1 including Al, Cr, Fe, Ni, and Co and group 2 including As, Cu, Mn, and Pb. In the first group, residual fraction is the dominant form of Al, Cr, Fe, Ni, and Co, with the average percentages of 96.3, 89.95, 88.85, 56, and 74%, respectively, indicating that they are strongly associated with minerals and resistant components of the solid matrix. Compared with the first group, the elements in the second group (As, Cu, Mn, and Pb) dominantly presented in the non-residual fractions (F1 + F2 + F3), indicating that they are strongly associated with minerals and resistant components of the solid matrix. Heavy metals in the non-residual fractions are more bioavailable than in residual fraction (Larner et al. 2006). According to Brady et al. (2014), changes in the environmental conditions commonly lead these elements to become easily bioavailable.

Concentrations of Al, Fe, and Cr are very low in exchangeable phase (0.08%, 0.26%, and 1.72% as mean values, respectively), limiting their potential toxicity as pollutants. Arsenic is found with the greatest proportion in the oxidizable phase, suggesting its strong affinity for combining with organic matter in sediments. Cadmium was mainly present in the exchangeable and bound to carbonate phase (more than 60%) in all the stations with the exception of station Frazergunj, where the Cd percentage represents only 25% of the total concentration. However, the concentration of Cd was found to be negligible in phases 2 and 3. The maximum labile Cd concentration was recorded at Babughat, located adjacent to the megacity Calcutta. Datta and Subramanian (1998) found that the concentrations of elements in the non-detrital phases were higher in stations sampled in the Hugli River around Calcutta than in samples collected along Brahmaputra and Meghna rivers. Lead mostly occurs in the reducible phase (55.70%) and demonstrates its strong affinity to Fe–Mn oxides in sediments. In the residual fraction, Zn exhibited a wide range of variations (38.5–70%), and the distribution pattern in each fraction followed the following decreasing order: residual > reducible > oxidizable > exchangeable and bound to carbonates.

The chemical partitioning of the investigated elements (Al, As, Cd, Co, Cr, Cu, Fe, Mn, Ni, Pb, and Zn) from each extraction step is shown in Fig. 6.3. Aluminum, Cr, and Fe are present mainly in the residual phase, representing 95.8–96.8%, 88.9–91%, and 83.0–94.7% of the total concentration, respectively, which implies that these elements are strongly linked to the inert fraction of the sediments. This result was in good agreement with data reported by several studies carried out

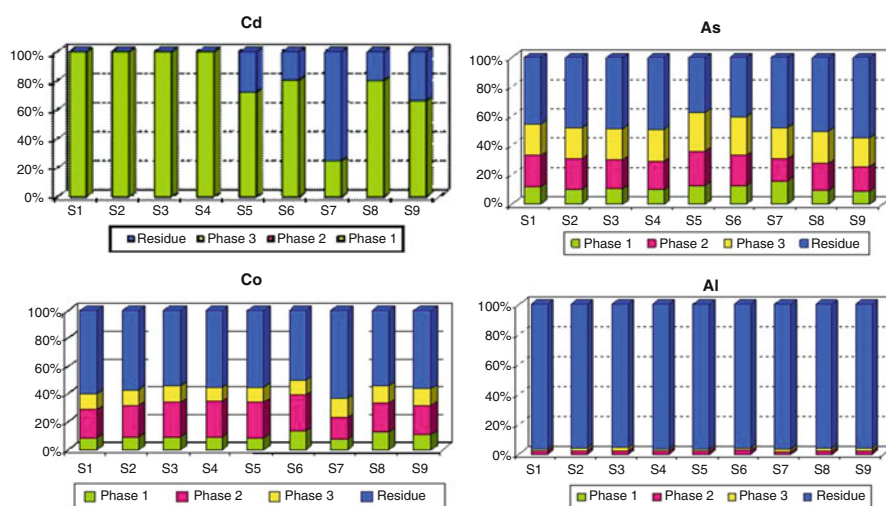

Fig. 6.3 Geochemical fractionation of trace metals (Al, As, Cd, Co, Cr, Cu, Fe, Mn, Ni, Pb, and Zn). Results are expressed as percentage of the total metal concentration [S1, Barrackpore; S2, Dakshineswar; S3, Uluberia; S4, Babughat, S5, Budge Budge; S6, Diamond Harbour; S7, Frazergunj; S8, Gangasagar; S9, Haribhanga]

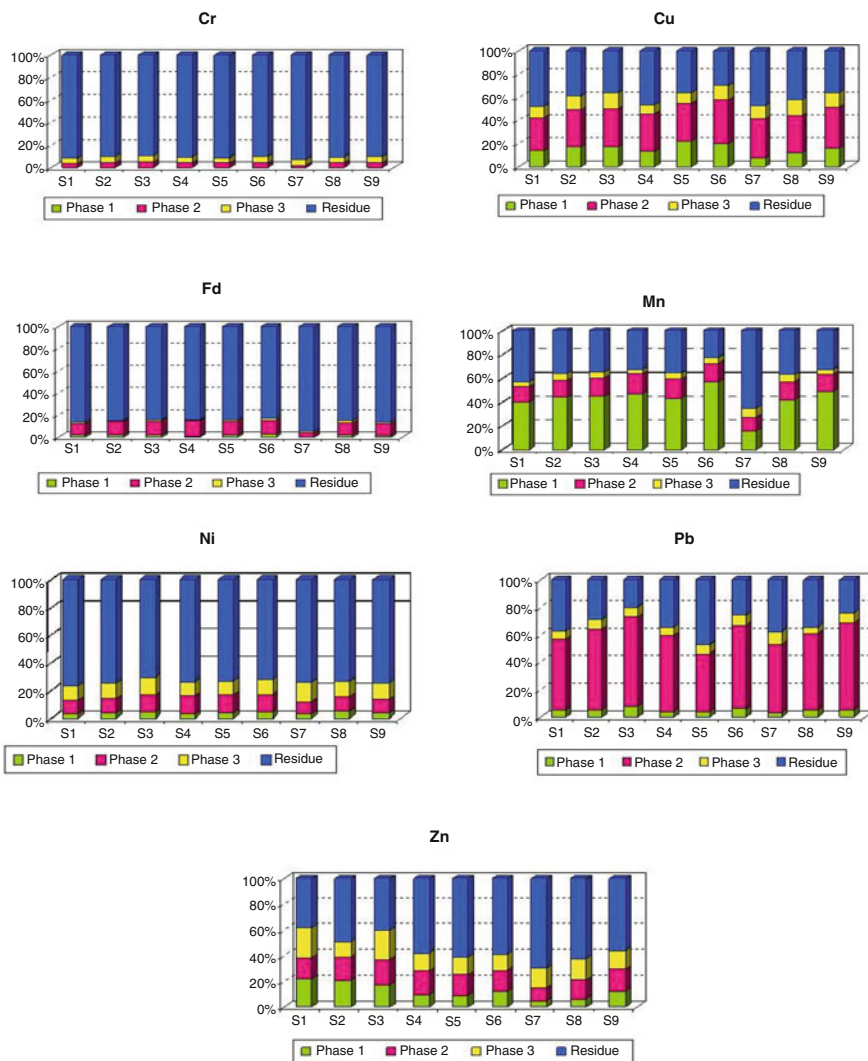

Fig. 6.3 (continued)

worldwide in marine coastal areas (Usero et al. 1998; Martin et al. 1998; Yuan et al. 2004; Takarina et al. 2004). The high percentage of Fe in the residual phase indicates that most of the iron exists as crystalline iron peroxides (goethite, limonite, magnetite, etc.). The remaining Fe is associated with the reducible phase (mean, 11.25%). Large amounts of Fe accumulate in the residual phase probably because it is basically of natural origin, being the most common element in the earth’s crust. Concentrations of Al, Fe, and Cr are very low in exchangeable phase

(0.08%, 0.26%, and 1.72% as mean values, respectively), limiting their potential toxicity as pollutants. It should be noted that sediments always act as reservoir for elements; therefore, their potential risk of pollution to environment has always to be considered. As, Co, Ni, and to some extent Zn, are found mainly in the residue (~50% of the total concentration).

Both the hazardous heavy metals Co and Ni are associated to the residue respectively for 56% and 74% of the total concentration, with a speciation similar in all the samples. A mean of 23% of Co is present in the phase 2. The maximum percentage of labile Co (~13%) was measured in Diamond Harbour and Gangasagar, and this enrichment may be due to a recent input of this element. The dominant proportion of Ni in the residual phase is in agreement with the results of other studies (Martin et al. 1998; Mester et al. 1998). Apart from the residue, Ni is also existed in phases 2 and 3 (about 10% in each phase). The metalloid arsenic is distributed mainly between the residual (mean 47%), the reducible, and the oxidizable phases (mean 19% and 22%, respectively). Acharyya et al. (2000) observed that arsenic is adsorbed to iron hydroxide-coated sand grains and to clay minerals in the sediments of the Ganges delta from West Bengal. Among the studied trace metals, this metalloid is recorded with the substantial proportion in the oxidizable phase coinciding with organic and sulfur compounds. Arsenic is present in the phase 1 for about 10% of the total content at the site Frezergunj where phase 1 rises up to 16%. The alluvial basin of the Ganges River is the most arsenic-contaminated area. Arsenic in solution is easily entrapped in the fine-grained organic-rich sediments deposited in the Ganges delta (Acharyya et al. 2000). The percentage of silt (lower than 70% except in Babughat and Dakshineswar) may have contributed to a low retention of dissolved arsenic As since coarse sediments are less efficient at retaining As. Cadmium was mainly present in the labile phase (more than 60%) in all the stations excepting the station Frezergunj, where the Cd labile percentage represents only 25% of the total concentration. Cadmium concentrations were negligible in phases 2 and 3. Maximum labile Cd concentration was measured at Babughat, adjacent to megacity Calcutta. Datta and Subramanian (1998) found that the concentrations of elements in the non-detrital phases were higher in stations sampled in the Hugli River around Calcutta than in samples collected along Brahmaputra and Meghna rivers. The petroleum refinery, industrial, and mining effluents carried by the Hugli River may be responsible for this higher concentrations of non-detrital fractions.

Approximately 40% of the total Cu concentration is bounded to the residual phase, while 33% of Cu is associated to Fe–Mn oxide and hydroxide (phase 2). The substantial portion of Cu in the residual phase is likely due to the fact that Cu is easily chemisorbed on or incorporated in clay minerals (Pickering 1986). Concentrations of Cu were low in exchangeable phase for all studied samples, showing a percentage of 7% (at the site Gangasagar) to 22% (at Babughat), with a mean value of 15%. Copper is characterized by high complex constant with organic matter; thus, it can be hypothesized that Cu is bound to labile organic matter such as lipids, proteins, and carbohydrates. On the other hand, high-element concentration

in labile phase could be linked to recent coastal inputs as endorsed by Ramirez et al. 2005.

Manganese may be considered as the most mobile element as this was present in all four geochemical fractions which were also endorsed by previous workers (Usero et al. 1998; Ngiam and Lim 2001). Maximum percentage (a mean of 42%) in the labile phase was encountered for this element. This is probably due to close association of Mn with carbonates (Dassenakis et al. 2003) as emphasized by others (Kiratli and Ergin 1996; Morillo et al. 2004). In this phase, weakly sorbed Mn retained on sediment surface by relatively weak electrostatic interactions, and this may be released by ion exchange processes as well as dissociation of Mn-carbonate phase (Tessier et al. 1979). The result indicates that considerable amount of Mn may be released into environment in more acidic conditions (Thomas et al. 1994), while maximum labile percentage was recorded in Diamond Harbour (57%). In contrast, its residual phase was 65% of the total concentration in Frezergunj, while the labile Mn constitutes a minor fraction (15%). A substantial Mn percentage was also recorded in the residual phase (mean 37.8%), followed by the reducible phase (14.7%), in which Mn exists as oxides in more reducing conditions in the sediments (Panda et al. 1995).

For Pb, Fe–Mn oxide phase (mean 55.7%) was dominant for all the geochemical phases, followed by the residual phase (mean 30.2%). Trace percentage of the total Pb is detected as exchangeable labile (mean 5.3%) as well as oxidizable phases (mean 6.8%). Atmospheric input as fallout from vehicular emission can be a potential source of Pb for Babughat where the reducible part is as high as 65% and only 19.9% of the total is associated with the residue. The prevalent high percentage of Pb in reducible phase is complying with the known ability of amorphous Fe–Mn oxides to scavenge Pb from solution (Dawson and Macklin 1998; Ramos et al. 1999). Caille et al. (2003) observed that resuspension of anoxic sediment results in a rapid desorption of Pb and Cu adsorbed to sulfides. Thus, a high element percentage in the reducible fraction can be considered an ecological hazard for the pelagic system because Fe and Mn species can be reduced into the pore waters during early diagenesis by microbially mediated redox reactions (Canfield 1989). Dissolution will also release Pb associated with oxide phases to the pore water possibly to the overlying water column (Petersen et al. 1995) and to benthic biota (Jones and Turki 1997). The major sources of Pb are derived from several anthropogenic sources, including agriculture in the drainage basin (Monbet 2006), auto-exhaust emission together with atmospheric deposition (Adriano 1986). In addition, a substantial contribution from the multifarious factories located in the upstream of the Hugli River (as shown in Fig. 6.2) dealing with lead-producing lead ingots and lead alloys plays a crucial role (Sarkar et al. 2007).

The percentage of Zn in residue is highly variable (38.5–70%), and the distribution pattern in each fraction was present in the following descending order: residual > reducible > oxidizable > exchangeable and bound to carbonates. Some difference in Zn speciation was recorded among the sampling sites: at Barrackpore, Dakshineswar, and Babughat about 40% of Zn is present in the residue, while in the other stations, this percentage increases to more than 60%. In station Barrackpore,

the exchangeable and oxidizable phases shared over 22% of the total Zn, whereas labile Zn was as low as 4.6% at Frazergunj. A major part of Zn (16.3%) is associated with Fe–Mn oxide phase, because of the high stability constants of Zn oxides. Fe oxides adsorb considerable quantities of Zn, and these oxides may also occlude Zn in the lattice structures (Banerjee 2003).

6.4.6 Statistical Analyses and Interpretations

Principal component analysis extracted two common factors that explained 83% of the total data variability (Fig. 6.4). Principal components with eigenvalue >1 were retained, as recommended by Cattell and Jaspers (1967). Majority of the elements were clustered together near the left side of the x-axis (Fig.), which contributed high positive loadings to factor 1 (F1). The first factor contributed 68% of total variance, showing strong positive loadings on Al, As, Co, Cr, Cu, Fe, Ni, and Zn. The elements which are grouped with Fe and Al indicate that they mainly originate from natural rock weathering processes and can be termed as “Al–Fe factor.” Many previous workers (Du Laing et al. 2009; Bi et al. 2006; Zhu et al. 2013a, b) have

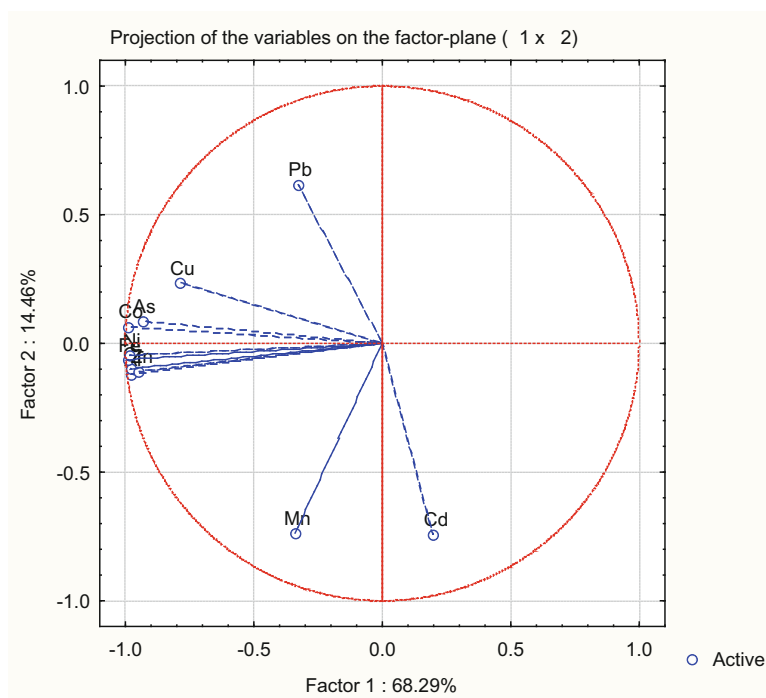

Fig. 6.4 Results of the principal component analysis (PCA) showing variable plot

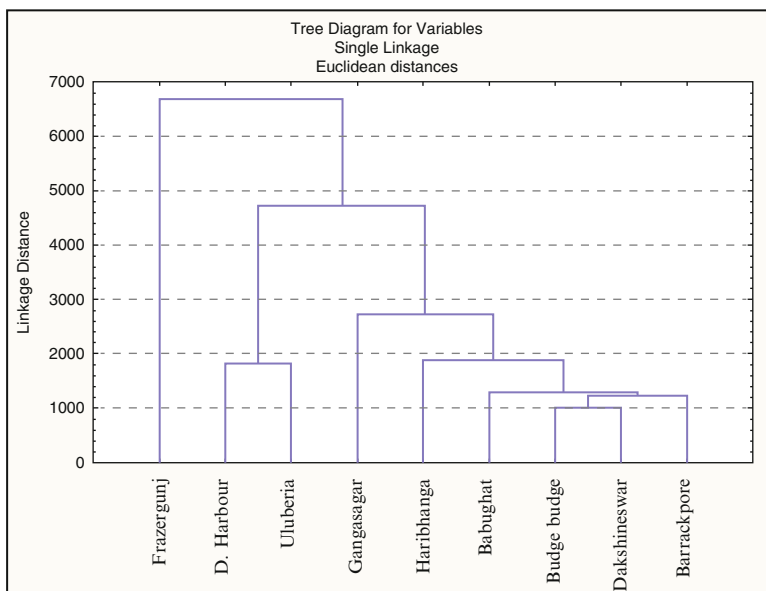

Fig. 6.5 Dendrogram showing clustering of monitoring sites in Sundarban wetland

endorsed that due to the large specific surface areas, iron hydroxides/oxides are excellent adsorbents and carriers of trace metals. The elements Cd, Mn, and Pb are scattered in the plot, suggesting its anthropogenic source in this environment. The second factor explained 15% of total variance.

Hierarchical cluster analysis (HCA) was carried out by applying Euclidean distances to study the distribution pattern of trace metals at the nine sampling stations (depicted in Fig. 6.5) which formed two distinct clusters. Cluster 1 comprising solitary sampling station Frazergunj, which could be considered as the station with the maximum percentage of elements, is bound to residual fraction. This site belonged to the marine coastal environment; and the textural properties of this station are characterized by high content of sand (~99%), indicating high-energy zone. However, it is worth mentioning that fine grain-size fractions ($\leq 63 \mu\text{m}$), due to their high surface area to mass ratio, can adsorb more metals and thus play a significant role in the distribution of TEs (Zhu et al. 2016).

The relationships between variables and the differences between stations were evaluated by PCA, considering 36 objects (four sediment phases for nine stations) as well as 11 trace metals studied. Two significant components were identified explaining 68.3% and 14.5% of the total variance. By examining the loadings of the variables on the components (Fig. 6.4), it is evident that majority of the trace metals (excepting Cd, Mn, and Pb) are significantly correlated. Most of Cd and Mn are present in the first phase unlike other elements: labile Cd and Mn represent more than 60% and 40% of the total concentration, respectively (except Frazergunj). Cadmium and Mn speciation can be explained to their sheer affinity for carbonates.

Lead is the only element bound to the reducible phase for more than 50%. This is a very reactive element in water column and bound to hydroxy- and oxyligands due to its scavenging-type behavior. Copper exhibited positive significant correlations with majority of the elements (except Cd and Mn).

In the score plot (Fig. 6.4), phases 1, 2, 3, and 4 (corresponding to labile, reducible, oxidizable, and residual phases) are identifiable by 1, 2, 3, and 4 suffix, respectively. Residue concentrations were characterized by negative values of PC1 in all the studied stations and consequently by high concentrations of Al, As, Co, Cr, Fe, Ni, and Zn. In contrast, semi-axis labile and oxidizable metal concentrations are distributed in the positive PC1. However, reducible concentrations are located along the positive PC2 semi-axis for all the stations, i.e., high Pb concentrations. The group formed by elements bound to organic matter and sulfides (phase 3) is characterized by low values of both PC1 and PC2. Therefore, a low percentage of elements (higher than 20% exclusively for all arsenic data and for Zn in stations Barrackpore and Budge Budge) is bound to the oxidizable phase, suggesting the presence of an oxidant environment. High Mn and Cd concentrations are associated with negative values of PC2; therefore, a relatively high concentration of labile Mn and Cd is present in almost all the samples (especially in Babughat). Samples are prevalently grouped in relation to the sediment geochemical phase, suggesting a similar element speciation among the stations. Station Frazergunj represents an exception; in fact the labile fraction is closely associated to the oxidizable phase group.

An HCA was performed by applying Euclidean distances to quantitatively identify specific groups of similar stations. In the dendrogram, two main clusters are very much distinguished for the sampling stations (as evidenced in Fig. 6.5): the first is represented by station Frazergunj (the marine environment, with a different grain size dominated by coarser particles), characterized by the highest element percentage bound to residue, while the second group is comprised of all other studied stations. A subgroup formed by two stations, namely, Diamond Harbour and Uluberia, can be individuated. An overall enrichment of trace element concentrations in finer particles than the coarser as the former is provided with larger surface area which is beneficial for absorption processes. This was also previously recorded by Ramirez et al. (2005) from sandy beaches in Chile, which is particularly evident for Cd.

6.5 Conclusion

Geochemical fractionation of trace metals is a novel approach to evaluate their toxicity in the context of bioavailability of the specific fractions, and it is related to physicochemical conditions such as pH, redox potential, carbonates, cationic exchange capacity, and organic matter in sediments. The outcome of BCR sequential extraction revealed the following valuable insights regarding the geochemical phases of heavy metal present in the estuarine: (1) Al, Cr, and Fe were mostly present in the residual phase, while other metals were present in the four phases

contributing different percentages; (2) the dominant Cd, Mn, and Pb proportion was detected in the non-residual fractions; and (3) Mn had the highest percentage in the labile phase, because of its well-known close association with carbonates. Most importantly, the results reveal more than 50% of the total As is present as labile; hence, immediate measure should be taken as there is every chance in releasing this toxic and potentially hazardous metalloid from the sediments under changing environment conditions. The studied estuarine environment is considerably constrained due to severe human-induced stresses like dredging, drilling, fishing, and agriculture activities. Hence, proper measures should be adopted to ensure appropriate treatment of industrial as well as domestic sewages before directly discharging into the river. This is strongly recommended for comprehensive consideration to develop effective and efficient management policies to control the metal discharge into the estuary.

References

- Acharyya SK, Lahiri S, Raymahashay BC, Bhowmilk A (2000) Arsenic toxicity of groundwater in parts of the Bengal basin in India and Bangladesh: the role of Quaternary stratigraphy and Holocene sea-level fluctuation. *Environ Geol* 39:231–238
- Adriano DC (1986) Trace elements in terrestrial environments. Springer, New York
- Agnieszka S, Wieslaw Z (2002) Application of sequential extraction and the ICPAES method for study of the partitioning of metals in fly ashes. *Microchem J* 72:9–16
- Anju M, Banerjee DK (2010) Comparison of two sequential extraction procedures for heavy metal partitioning in mine tailings. *Chemosphere* 78:1393–1402
- Banerjee ADK (2003) Heavy metal levels and solid phase speciation in street dusts of Delhi, India. *Environ Pollut* 123(1):95–105
- Bi XY, Feng XB, Yang YG, Qiu GL, Li GH, Li FL, Liu TZ, Fu ZY, Jin ZS (2006) Environmental contamination of heavy metals from zinc smelting areas in Hezhang County, western Guizhou, China. *Environ Int* 32:883–890
- Borovec Z, Tolar V, Mraz L (1993) Distribution of some metals in sediments of the central part of the Labe (Elbe) River, Czech Republic. *Ambio* 22:200–205
- Brady JP, Ayoko GA, Martens WN, Goonetilleke A (2014) Enrichment, distribution and sources of heavy metals in the sediments of Deception Bay, Queensland. *Australia Mar Pollut Bull* 81:248–255
- Caille N, Tiffreau C, Leyval C, Morel JL (2003) Solubility of metals in an anoxic sediment during prolonged aeration. *Sci Total Environ* 301:239–250
- Calmano W, Hong J, Förstner U (1993) Binding and mobilization of heavy metals in contaminated sediments affected by pH and redox potential. *Water Sci Technol* 28(8–9):53–58
- Campanella L, D’Orazio D, Petronio BM, Pietrantonio E (1995) Proposal for a metal speciation study in sediments. *Anal Chim Acta* 309:387–393
- Canfield DE (1989) Reactive iron in marine sediments. *Geochim Cosmochim Acta* 53:619–632
- Cattell RB, Jaspers J (1967) A general plasmode (no. 30-10-5-2) for factor analytic exercises and research. *Multivar Behav Res Monogr* 67:1–212
- Chatterjee M, Silva Filho EV, Sarkar SK, Sella SM, Bhattacharya A, Satpathy KK (2007) Distribution and possible source of trace elements in the sediment cores of a tropical macrotidal estuary and their ecotoxicological significance. *Environ Int* 33:346–356
- Chatterjee M, Massolo S, Sarkar SK, Bhattacharya AK, Bhattacharya BD, Satpathy KK, Saha S (2009) An assessment of trace element contamination in intertidal sediment cores of Sunderban

- mangrove wetland, India for evaluating sediment quality guidelines. *Environ Monit Assess* 150:307–322
- Cuong TD, Obbard JP (2006) Metal speciation in coastal marine sediments from Singapore from Singapore using a modified BCR-sequential extraction procedure. *Appl Geochem* 21:1335–1346
- Dassenakis M, Adrianos H, Depiazzi G, Konstantas A, Karabela M, Sakellari A, Scoullas M (2003) The use of various methods for the study of metal pollution in marine sediments, the case of Euvoikos Gulf, Greece. *Appl Geochem* 18:781–794
- Datta DK, Subramanian V (1998) Distribution and fractionation of heavy metals in the surface sediments of the Ganges–Brahmaputra–Meghna river system in the Bengal Basin. *Environ Geol* 36:93–101
- Dawson EJ, Macklin MG (1998) Speciation of heavy metals in floodplain and flood sediments: a reconnaissance survey of the Aire Valley, West Yorkshire, Great Britain. *Environ Geochem Health* 20:67–76
- de Carvalho Araújo Júnior JM, Ferreira TO, Suarez-Abelenda M, Nóbrega GN, Brito Marques Albuquerque AG, Bezerra A d C, Otero XL (2016) The role of bioturbation by *Ucides cordatus* crab in the fractionation and bioavailability of trace metals in tropical semiarid mangroves. *Mar Pollut Bull* 111:194–202
- Dowling CB, Poreda RJ, Basu AR, Aggarwal PK (2002) Geochemical study of arsenic release mechanisms in the Bengal Basin groundwater. *Water Resour Res* 38(9):1173–1190
- Du Laing G, Chapagain SK, Dewispelaere M, Meers E, Kazama F, Tack FMG, Rinklebe J, Verloo MG (2009) Presence and mobility of arsenic in estuarine wetland soils of the Scheldt estuary (Belgium). *J Environ Monit* 11:873–881
- Eggleton J, Thomas KV (2004) A review of factors affecting the release and bioavailability of contaminants during sediment disturbance events. *Environ Int* 30:973–980
- Farnham IM, Johannesson KH, Singh AK, Hodge VF, Stetzenbach KJ (2003) Factor analytical approaches for evaluating groundwater trace element chemistry data. *Anal Chim Acta* 490:123–138
- Filgueiras AV, Lavilla I, Bendicho C (2002) Chemical sequential extraction for metal partitioning in environmental solid samples. *J Environ Monit* 4:823–857
- Filgueiras AV, Lavilla I, Bendicho C (2004) Evaluation of distribution, mobility and binding behaviour of heavy metals in surficial sediments of Louro River (Galicia, Spain) using chemometric analysis: a case study. *Sci Total Environ* 330(1–3):115–129
- Gao XL, Li PM (2012) Concentration and fractionation of trace metals in surface sediments of intertidal Bohai Bay, China. *Mar Pollut Bull* 64:1529–1536
- Gleyzes C, Tellier S, Astruc M (2002) Fractionation studies of trace elements in contaminated soils and sediments: a review of sequential extraction procedures. *TrAC Trends Anal Chem* 21:451–467
- Gomez Ariza JL, Giraldez I, Sanchez-Rodas D, Moralesm E (2000) Metal sequential extraction procedure optimized for heavily polluted and iron Oxide rich sediments. *Anal Chim Acta* 414:151–164
- Hass A, Fine P (2010) Sequential selective extraction procedures for the study of heavy metals in soils, sediments, and waste materials—a critical review. *Crit Rev Environ Sci Technol* 40:365–399
- He Z, Song J, Zhang N, Zhang P, Xu Y (2009) Variation characteristics and ecological risk of heavy metals in the south Yellow Sea surface sediments. *Environ Monit Assess* 157(1):515–528
- Ho D, Evans GJ (1997) Operational speciation of cadmium, copper, lead and zinc in the NIST standard reference materials 2710 and 2711 (Montana soil) by the BCR sequential extraction procedure and flame atomic absorption spectrometry. *Anal Commun* 34:363–364
- Ianni C, Magi E, Rivaro P, Ruggieri N (2000) Trace metals in Adriatic coastal sediments: distribution and speciation pattern. *Toxicol Environ Chem* 78:73–92

- Ianni C, Ruggieri N, Rivaro P, Frache R (2001) Evaluation and comparison of two selective extraction procedures for heavy metal speciation in sediments. *Anal Sci* 17:1273–1278
- Islam MS, Ahmed MK, Raknuzzaman M, Habibullah AI M, Md Islam MK (2015) Heavy metal pollution in surface water and sediment: a preliminary assessment of an urban river in a developing country. *Ecol Indic* 48:282–291
- Janaki-Raman D, Jonathan MP, Srinivasalu S, Armstrong-Altrin JS, Mohan SP, Ram-Mohan V (2007) Trace metal enrichments in core sediments in Muthupet mangroves, SE coast of India: application of acid leachable technique. *Environ Pollut* 145:245–257
- Jonathan MP, Ram Mohan V (2003) Heavy metals in sediments of the inner shelf off the Gulf of Mannar, southeast coast of India. *Mar Pollut Bull* 46:263–268
- Jones B, Turki A (1997) Distribution and speciation of heavy metals in surficial sediments from the Tees estuary, north-east England. *Mar Pollut Bull* 34(10):768–779
- Kaasalainen M, Yli-Halla M (2003) Use of sequential extraction to assess metal partitioning in soils. *Environ Pollut* 126(2):225–233
- Keshavarzi B, Ebrahimi P, Moore F (2014) A GIS-based approach for detecting pollution sources and bioavailability of metals in coastal and marine sediments of Chabahar Bay, SE Iran. *Chem Erde Geochem* 75(2):185–195. <http://dx.doi.org/10.1016/j.chemer.2014.11.003>
- Kiratli N, Ergin M (1996) Partitioning of heavy metals in surface Black Sea sediments. *Appl Geochem* 11:775–788
- Larner BL, Seen AJ, Townsend AT (2006) Comparative study of optimized BCR sequential extraction scheme and acid leaching of elements in the certified reference material NIST 2711. *Anal Chim Acta* 556:444–449
- Liu Z, Pan S, Sun Z, Ma R, Chen L, Wang Y, Wang S (2015) Heavy metal spatial variability and historical changes in the Yangtze River estuary and North Jiangsu tidal flat. *Mar Pollut Bull* 98:115–129
- Long ER, Ingersoll CG, MacDonald DD (2006) Calculation and uses of mean sediment quality guideline quotients: a critical review. *Environ Sci Technol* 40:1726–1736
- Lopez-Sanchez JF, Sahuquillo A, Fiedler HD, Rubio R, Rauret G, Muntau H, Quevauviller P (1998) CRM 601, a stable material for its extractable content of heavy metals. *Analyst* 123:1675–1677
- MacDonald DD, Ingersoll CG, Berger T (2000) Development and evaluation of consensus-based sediment quality guidelines for freshwater ecosystems. *Arch Environ Contam Toxicol* 39:20–31
- Martin R, Sanchez DM, Gutierrez AM (1998) Sequential extraction of U, Th, Ce, La and some heavy metals in sediments from Ortigas River, Spain. *Talanta* 46:1115–1121
- Mester Z, Cremisini C, Ghiara E, Morabito R (1998) Comparison of two sequential extraction procedures for metal fractionation in sediment samples. *Anal Chim Acta* 259:133–142
- Monbet P (2006) Mass balance of lead through a small macrotidal estuary: the Morlaix River estuary (Brittany, France). *Mar Chem* 98(1):59–80
- Moore F, Nematollahi MJ, Keshavarzi B (2015) Heavy metals fractionation in surface sediments of Gowatr bay-Iran. *Environ Monit Assess* 187:4117
- Morillo J, Usero J, Gracia I (2004) Heavy metal distribution in marine sediments from the southwest coast of Spain. *Chemosphere* 55:431–442
- Müller G (1979) Schwermetalle in den sedimenten des Rheins-Veränderungen seit. *Ther Umsch* 79:133–149
- Ngiam LS, Lim PE (2001) Speciation patterns of heavy metals in tropical estuarine anoxic and oxidized sediments by different sequential extraction schemes. *Sci Total Environ* 275:53–61
- Oyeyiola AO, Olayinka KO, Alo B (2011) Comparison of three sequential extraction protocols for the fractionation of potentially toxic metals in coastal sediments. *Environ Monit Assess* 172(1–4):319–327
- Palleyi S, Banoo S, Kar RN, Panda CR (2015) Textural and geochemical characteristics of off shore sediment of North Bay of Bengal: a statistical approach for marine metal pollution. *Int J Sediment Res* 30:208–222

- Panda D, Subramanian V, Panigrahy RC (1995) Geochemical fractionation of heavy metals in Chilka Lake (east coast of India)—a tropical coastal lagoon. *Environ Geol* 26:199–210
- Petersen W, Wallman K, Li PL, Schroeder F, Knauth HD (1995) Exchange of trace elements at the sediment–water interface during early diagenesis processes. *Mar Freshw Res* 46:19–26
- Pickering WF (1986) Metal ion speciation—soil and sediments (a review). *Ore Geol Rev* 1:83–146
- Ragno G, De Luca M, Ioele G (2007) An application of cluster analysis and multivariate classification methods to spring water monitoring data. *Microchem J* 87:119–127
- Ramirez M, Massolo S, Frache R, Correa J (2005) Metal speciation and environmental impact on sandy beaches due to El Salvador copper mine, Chile. *Mar Pollut Bull* 50:62–72
- Ramos L, González M, Hernández L (1999) Sequential extraction of copper, lead, cadmium, and zinc in sediments from Ebro River (Spain): relationship with levels detected in earthworms. *Bull Environ Contam Toxicol* 62:301–308
- Saha M, Sarkar SK, Bhattacharya B (2006) Interspecific variation in heavy metal body concentrations in biota of Sunderban mangrove wetland, northeast India. *Environ Int* 32:203–207
- Sahuquillo A, López-Sánchez JF, Rubio R, Rauret G, Thomas RP, Davidson CM, Ure A (1999) Use of a certified reference material for extractable trace metals to assess sources of uncertainty in the BCR three-stage sequential extraction procedure. *Anal Chim Acta* 382:317–327
- Salomon W, Förstner U (1984) *Metals in the hydrocycle*. Springer, Berlin
- Sarkar SK, Bhattacharya B, Debnath S, Bandopadhyaya G, Giri S (2002) Heavy metals in biota from Sunderban wetland ecosystem, India: implications to monitoring the environmental assessment. *Aquat Ecosyst Health Manag* 5(2):207–214
- Sarkar SK, Bilinski SF, Bhattacharya A, Saha M, Bilinski H (2004) Levels of elements in the surficial estuarine sediments of the Hugli river, northeast India and their environmental implications. *Environ Int* 30:1089–1098
- Sarkar SK, Saha M, Takada H, Bhattacharya A, Mishra P, Bhattacharya B (2007) Water quality management in the lower stretch of the river Ganges, east coast of India: an approach through environmental education. *J Clean Prod* 15:1559–1567
- Schramel O, Michalke B, Kettrup A (2000) Study of the copper distribution in contaminated soils of hop fields by single and sequential extraction procedures. *Sci Total Environ* 263:11–22
- Sen M, Chakraborty AK, Ghosh AK, Bahadropadhyaya KK (1994) Water quality of the Hooghly: some aspects. *Seas Explor*:14–22
- Statsoft Inc (2001) *Statistica (Data Analysis Software System)*, version 6, www.statsoft.com
- Subramanian V, Mohanachandran G (1990) Heavy metals distribution and enrichment in the sediments of southern east coast of India. *Mar Pollut Bull* 21:324–330
- Sunil Kumar R (1996) Distribution of organic carbon in the sediments of Cochin mangroves, south west coast of India. *Indian J Mar Sci* 25:274–276
- Sutherland RA (2010) BCR®: a review of 10-years of sequential extraction analyses. *Anal Chim Acta* 680:10–20
- Takarina ND, Browne DR, Risk MJ (2004) Speciation of heavy metals in coastal sediments of Semarang, Indonesia. *Mar Pollut Bull* 49:854–874
- Tam NFY, Wong YS (2000) Spatial variation of heavy metals in surface sediments of Hong Kong mangrove swamps. *Environ Pollut* 110:195–205
- Tessier A, Campbell PGC, Bisson M (1979) Sequential extraction procedure for the speciation of particulate trace metals. *Anal Chem* 51:844–851
- Thomas RP, Ure AM, Davidson CM, Littlejohn D, Rauret G, Rubio R, López-Sánchez JF (1994) Three-stage sequential extraction procedure for the determination of metals in river sediments. *Anal Chim Acta* 286:423–429
- Ure AM, Quevauviller P, Muntau H, Griepink B (1993) Speciation of heavy metals in solids and harmonization of extraction techniques undertaken under the auspices of the BCR of the Commission of the European Communities. *Int J Environ Anal Chem* 51:135
- Usero J, Gamero M, Morillo J, Gracia I (1998) Comparative study of three sequential extraction procedures for metals in marine sediments. *Environ Int* 24:478–496

- Walkey A, Black TA (1934) An examination of the Dugtijaraff method for determining soil organic matter and proposed modification of the chronic and titration method. *Soil Sci* 37:23–38
- Yan C, Li Q, Zhang X, Li G (2010) Mobility and ecological risk assessment of heavy metals in surface sediments of Xiamen Bay and its adjacent areas. *China Environ Earth Sci* 60 (7):1469–1479
- Yuan C, Shi J, He B, Liu J, Liang L, Jiang G (2004) Speciation of heavy metals in marine sediments from the East China Sea by ICP-MS with sequential extraction. *Environ Int* 30 (6):769–783
- Zdenek B (1996) Evaluation of the concentrations of trace elements in stream sediments by factor and cluster analysis and the sequential extraction procedure. *Sci Total Environ* 177:237–250
- Zhu ZM, Li ZG, Bi X, Han ZX, Yu GH (2013a) Response of magnetic properties to heavy metal pollution in dust from three industrial cities in China. *J Hazard Mater* 246-247:189–198
- Zhu ZM, Sun GY, Bi XY, Li ZG, Yu GH (2013b) Identification of trace metal pollution in urban dust from kindergartens using magnetic, geochemical and lead isotope analyses. *Atmos Environ* 77:9–15
- Zhu Z, Xue J, Deng Y, Chen L, Liu J (2016) Trace metal contamination in surface sediments of intertidal zone from Qinhuangdao, China, revealed by geochemical and magnetic approaches: distribution, sources, and health risk assessment. *Mar Pollut Bull* 105:422–429

Organotin Compounds in Surface Sediments of Sundarban Wetland and Adjacent Coastal Regions

7

Abstract

Assessment of sediment quality is of prime importance for proper management of marine environment as required by the Water Framework Directive (2000/60/EC) (WFD) and Marine Strategy Framework Directive (2008/56/EC) (MSFD) that considered sediment as the crucial component for sound management of water bodies. Organotin compounds (tributyltin (TBT), dibutyltin (DBT), monobutyltin (MBT), and triphenyltin (TPhT)) are widely used as active ingredients in marine antifouling coating to resist the settlement of biofouling agents. The chapter explores the quantification and speciation of butyltin contamination levels in surficial intertidal sediments of Indian Sundarban mangrove wetland as well as adjacent Hooghly (Ganges) estuary. Concentration of TBT, DBT, and MBT exhibited a wide range of variations for 16 studied stations of diverse environmental stresses. The correlation coefficient values showed positive significant values between the compounds as follows: MBT and DBT ($r = 0.62$; $p = 0.01$) and DBT and TBT ($r = 0.54$; $p = 0.03$). The degradation of TBT assessed by BT degradation index (BDI) revealed recent input of BTs at eight studied stations and very recent degradation or absolutely no degradation at four other stations. Based on Australian sediment quality guidelines (SQGs), it is revealed that TBT concentrations in majority of study sites are high and to be considered as potential threats for sustenance of benthic organisms.

Keywords

Organotin compounds • Butyltin • Contaminants • Sediment • Indian Sundarban

7.1 Introduction

Organotin compounds (OTCs) are ubiquitous, persistent synthetic contaminant with a wide range of applications ranging from biocides in agriculture and as catalysts and plastic stabilizers in industry. However, the main input of OTCs as

butyltin derivatives (BTs) to the sea originates from antifouling paints that are used to protect ship hulls from biofouling organisms (e.g., barnacles). Dibutyltin (DBT) and monobutyltin (MBT) were used as stabilizing additives against the effects of light and heat on PVC (Ebdon et al. 1998; Hoch 2001; Olushola Sunday et al. 2012). In the 1960s, tributyltin (TBT) also began to be used as an antifouling agent in paints for the hulls of ships and boats and surfaces of stationary structures in prolonged contact with seawater. TBT controls the growth and attachment of barnacles, mussels, tubeworms, algae, and other marine fouling organisms, and its application has resulted in enormous savings to the shipping industry. However, the widespread use of these compounds resulted in a serious problem for the marine ecosystems. TBT has been defined as the most toxic substance ever introduced into the marine environment (Goldberg 1986; Sonak et al. 2009), even at very low concentrations (Szpunara et al. 1996; Hoch 2001).

The International Convention on the Control of Harmful Antifouling Systems on Ships, recognized as the AFS Convention, was implemented on 17 September 2008 (IMO 2001). The convention was adopted from various alarming reports on various toxic and sublethal effects of organotins to both pelagic and benthic organisms, chiefly by tributyltin (TBT) and triphenyltin (TPhT). These biocide compounds have been extensively used as active ingredients in marine antifouling paints due to its longer durability, higher efficiency, and low-cost value. They resist the settlement and growth of the biofouling organisms on structures such as ship hulls, boat, etc. The International Maritime Organization (IMO) has also prohibited the usage of these OT compounds as a potential component of antifouling paint (Sonak et al. 2009; Antizar-Ladislao 2008; Rodríguez et al. 2010). However, imposition of the order did not instantly solve to remove TBT due to its hydrophobicity and excellent retaining capacity in sediments.

Both TBT and TPhT disrupt the endocrine system of target organisms (especially gastropods and bivalve mollusks), leading to sterility and species extinctions as a consequence of reproductive and developmental disorders (Alzieu 1998; Hoch 2001), gastropod imposex (masculinization of females), mussel larva mortality, and oyster malformation. The classic example is related to the occurrence of imposex in the dog whelk *Nucella lapillus* which is hypersensitive to TBT, and this causes female to grow a vas deferens and a penis. These block the opening of the female genital duct and thus have a dramatic impact on this predatory gastropod mollusk.

The priority pollutant TBT is leached from antifouling paints quickly absorbed by organic materials in the water (bacteria, algae, or suspended particulate matter) (Luan et al. 2006; Antizar-Ladislao 2008) and later on incorporated into tissue of filter-feeding organisms and finally accumulated animals of higher trophic levels (e.g., fish, birds, and mammals). Due to its sublethal effects and persistence (Kim et al. 2011; Silva et al. 2014), TBT produced shell calcification anomalies in oyster farming and severe sexual disorders especially in marine gastropod mollusk species (Qiu et al. 2011; Choi et al. 2013; Silva et al. 2014). TBT still continues to represent a great environmental problem for marine organisms due to its half-life of about 19 years (Adelman et al. 1990). India has the hazardous waste (management and handling) rules, 1989 (amended in 2003). This provides the detailed guidelines for

the manufacturer storage and import of hazardous wastes. So far, there is no legal ban on the use of TBT-based antifouling paints in India. Most importantly there are scarce information regarding the level of organotin in biotic and abiotic compartments from coastal regimes in India (Rajendran et al. 2001; Bhosle et al. 2004, 2006; Garg et al. 2011).

The present chapter has been devoted to determine the concentration of TBT along with its degradation products, dibutyltin (DBT) and monobutyltin (MBT), in surficial sediments covering 16 monitoring sites of Sundarban estuarine complex and Hugli River suffering from increasing trade and maritime activities and thus deserves special attention in the context of contamination.

7.2 Methodology

7.2.1 Study Area and Sampling Design

The Hugli River (~260 km long), a major distributary of the Ganges River in the east coast of India, provides multiple ecosystem services and provides perpetual water supply to the plains of West Bengal for a number of activities, such as irrigation, navigation of small ships and fishing boats, and human and industry consumption together with fishing. The wave–tide climate of this low-lying tropical coast primarily controls the sediment dispersal patterns. Biogenic subduction and resuspension also play a significant role in the vertical and lateral transportation of sediments.

Surface marine sediments (top 3–5 cm of the surface) were collected in triplicate from intertidal regions using a grab sampler during low tide from 16 monitoring sites covering both Hugli River as well as Sundarban mangrove wetland, such as Barrackpore, Dakshineswar, Babughat, Budge Budge, Diamond Harbour, Lot 8, Ghushighata, Dhamakhali, Canning, Gosaba, Jharkhali, Kakdwip, Chemaguri, Bakkhali, Gangasagar, and Haribhanga. Sampling locations were selected considering the sediment dispersal patterns along the drainage network systems (Table 7.1) and suspected presence of BTs as a consequence of boating activities. The stations are representative of the variable environmental and energy regimes that cover a wide range of substrate behavior, wave–tide climate, and intensity of bioturbation (animal–sediment interaction), geomorphic–hydrodynamic regimes, and distances from the sea, Bay of Bengal. Samples were pooled and properly mixed, stored in sterilized plastic bags in the ice box, and subsequently oven-dried at 50 °C. Later on they were very gently disaggregated, individually transferred into pre-cleaned inert polypropylene bags, and finally stored in deep freeze prior to analysis. The pooled samples were each segregated into two aliquots: one unsieved for sediment geochemical characteristics and the other sieved through 63- μm metallic sieves to be used for BT analysis.

Table 7.1 Description of the sampling stations^a along with respective ecological stresses

Sampling station	Description of ecological stresses
<i>Location of the station along the stretch of the Hugli River</i>	
Barrackpore	Upstream, main stresses are industrial effluents, domestic sewage disposal, boating, bathing, occasional immersion of idols
Dakshineswar	Upstream, main stresses being industrial and domestic effluents, recreational and traditional practices, bathing, boating, etc.
Babughat	Upstream, domestic and industrial effluents, bathing, frequent immersion of idols, boating, etc.
Budge Budge	Upstream, industrial stress mainly power plant discharges, domestic sewage, boating, etc.
Diamond Harbour	Downstream, mainly boating, recreational activities, bating, etc.
Lot 8	Frequent dredging, boating, fishing, etc.
<i>Location of the stations in Sundarban coastal regions</i>	
Ghushighata	Effluents from east Kolkata tanneries, agricultural and other anthropogenic activities, boating
Dhamakhali	Effluents from tanneries, boating, and fishing
Canning	Boating and fishing
Gosaba	Boating, fishing, and anthropogenic activities
Jharkhali	Boating, fishing, and aquacultural activities
Kakdwip	Boating, aquacultural and agricultural runoffs, fishing, dredging, etc.
Chemaguri	Boating and fishing
Bakkhali	Tourist activities, boating, and anthropogenic wastes
Gangasagar	Boating, tourist activities, dredging, fishing, agricultural, domestic and aquacultural practices
Haribhanga	Boating and fishing

^aSee Fig. 6.1 for sampling site location

7.2.2 Analytical Protocol

The sediment samples were characterized for particle size, pH, and organic carbon. Particle size was determined by sieving the dried samples in a Ro-Tap Shaker (Krumbein and Pettijohn 1938) manufactured by W.S. Tyler Company, Cleveland, Ohio, and statistical computation of textural parameters was done by using the formulae of Folk and Ward (1957). The determination of pH was conducted with a digital pH meter 101E Deluxe Model (EI Products, India) using a combination glass electrode manufactured by MS Electronics (India) Pvt. Ltd. Organic carbon (C_{org}) content of the soil was determined following a rapid titration method (Walkey and Black 1934) after oxidizing with potassium dichromate ($K_2Cr_2O_7$) in the presence of sulfuric acid (H_2SO_4).

Sieved sediment samples (5.0 g) were weighed into 25-ml beakers and spiked with 150 μ l of the surrogate, triphenyltin chloride (TPT), resulting in a concentration of 3 ng g^{-1} . Samples were extracted using an ASE 300 solvent extractor (DIONEX, Camberley, UK) using a method (100 °C \times 25 min) based upon

DIONEX Application note 339 (2001). Sediment extracts were analyzed on a Thermo Finnigan gas chromatography (GC) equipped with a mass selective detector (MSD), coupled to a Thermo TriPlus autosampler (all Thermo Fisher, Loughborough, UK). Analyses of organotins were worked out with the help of GC-MS (split/splitless injection) maintaining the standard analytical protocol devised at the National Institute for Coastal and Marine Management/RIKZ (Stronkhorst et al. 2004). Blanks (solvent) and spiked blanks (standards spiked into solvent) were concurrently analyzed. The calibration was frequently checked by the repeated analyses of quality control standards. Recoveries of surrogate standards and internal standards in samples were above 80% throughout all sample analyses. Results of the standard reference materials used to ensure the QC/QA of the analysis are shown in Table 7.2.

7.2.3 Statistical Analysis

STATISTICA software (StatSoft Inc. 2011) was used to calculate for Pearson product correlation coefficients between BTs and organic carbon in sediment.

7.3 Results and Discussion

7.3.1 Sediment Geochemistry

The sediment geochemistry in the context of pH, textural properties, and C_{org} , as depicted in Table 7.3, was characteristically different for 16 study sites, and the prevalent variations were overall reflected in the BT concentrations as evidenced in Table 7.4. Values of pH values exhibited small range of variations, from slightly acidic to basic (6.5–8.8). The small variation in pH could be attributed to buffering capacity of the seawater that causes the change of pH within a very narrow limit and could be a causative factor (Riley and Chester 1971). The acidic nature was only pronounced at the site Jharkhali, which may be partly due to the oxidation of iron (II) disulfide (FeS_2) and iron (II) sulfide (FeS) to sulfate ion (SO_4^{2-}) and partly to the decomposition of mangrove litter and hydrolysis of tannin (present in both condensed and hydrolyzable forms) in mangrove plants which release various kinds of organic acids (Liao 1990). Low organic carbon (C_{org}) values (<1%) were pronounced in all study sites, reaching the maximum value (1.04%) at Ghushighata. The prevalent low C_{org} values were the cumulative result of sedimentation and mixing processes at the sediment–seawater interface where the rate of delivery and rates of degradation by microbial-mediated processes can be high (Canuel and Martens 1993). Very low C_{org} values in intertidal zone sediments in Sundarban have been also recorded in previous studies and related to the poor absorbability of organics in negatively charged quartz grains, which predominate in sediments of this estuarine system (Sarkar et al. 2004; Chatterjee et al. 2007). Textural analyses displayed a wide

Table 7.2 Results of the analyses of certified reference materials (CRMs)

	MBT		DBT		TBT		TeBT	TPT	Weight of soil (g)	Volume of solvent (ml)
	Conc. (mg kg ⁻¹)	Recovery (%)	Conc. (mg kg ⁻¹)	Recovery (%)	Conc. (mg kg ⁻¹)	Recovery (%)				
057 Reference material 1	0.14	22.9	0.47	60.8	0.45	93.8	91.0	-	1.10	3.0
057 Reference material 2	0.11	17.8	0.37	48.1	0.38	79.6	96.4	-	1.01	3.0
057 Reference material 3	0.08	12.3	0.39	50.2	0.44	91.1	90.5	-	1.10	3.0
057 Reference material 4	0.16	26.2	0.45	58.7	0.47	98.9	97.2	-	1.02	3.0
057 Reference material 5	0.17	27.7	0.46	60.1	0.43	88.9	103.3	-	1.02	3.0
Average for 1 g (<i>n</i> = 5) sample size				MBT			DBT		TBT	
SD for 1 g sample size (<i>n</i> = 5)				0.13			0.43		0.43	
RSD (<i>n</i> = 5)				0.04			0.05		0.03	
Average recovery (%) (<i>n</i> = 5)				29.63			10.74		7.88	
SD for 1 g sample size (<i>n</i> = 5)				21.4			55.6		90.5	
RSD (<i>n</i> = 5)				6.34			5.97		7.13	
				29.63			10.74		7.88	

Table 7.3 Physicochemical properties of the 16 sediment sampling stations^a of marine sediments of the Hugli River and Indian Sundarban mangrove wetland

Collecting station	C_{org} (%)	pH	Sand (%)	Silt (%)	Clay (%)
Location					
Barrackpore	0.59	7.9	10.59	69.91	19.50
Dakshineswar	0.52	7.8	1.21	78.4	20.39
Babughat	0.57	7.9	0.97	86.74	12.29
Budge Budge	0.40	7.6	11.98	85.20	2.82
Diamond Harbour	0.41	8.4	11.61	84.12	4.27
Lot 8	0.78	8.3	1.15	84.82	14.03
Ghushighata	1.04	8.0	11.85	30.85	57.30
Dhamakhali	0.72	8.1	1.00	85.80	13.20
Canning	0.83	8.0	2.10	67.63	30.27
Gosaba	0.67	8.7	0.68	48.66	50.66
Jharkhali	0.81	6.5	13.04	68.36	18.60
Kakdwip	0.66	8.8	6.18	5.74	88.08
Chemaguri	0.55	8.1	22.80	67.70	9.50
Bakkhali	0.04	8.1	98.18	0.84	0.98
Gangasagar	0.41	8.1	25.97	63.53	10.48
Haribhanga	0.40	8.1	23.65	62.05	14.30

^aSee Fig. 6.1 for sampling site location

range of variations from silty clay to sandy which are linked to vigorous estuarine physical processes such as mixing, suspension, resuspension, and flocculation.

7.3.2 Levels of Butyltin Contamination

There exists a wide range of variations of MBT, DBT, and TBT concentrations in sediments studied at 16 stations covering both Sundarban and Hugli River (Table 7.4). BTs were encountered at all the monitoring sites, ranging from below detection level reaching maximum concentrations of TBT at Haribhanga (84.2 ng g^{-1}), DBT at Dhamakhali (26.4 ng g^{-1}), and MBT at Bakkhali (48.0 ng g^{-1}). TBT undergoes microbial degradation and photodegradation in marine environments, decomposed into DBT and MBT, considered as less toxic products than TBT (Hoch 2001; Marcic et al. 2006). The observed elevated TBT concentration might be attributed to intense traffic of boats and other vessels, using TBT-based antifouling paints as well as plastic manufacturing industries located in the upstream of Hooghly River, in which TBT may be used as a stabilizer. The observed spatial variation trends are quite challenging to interpret due to multiple point and nonpoint sources of inputs, varying energy and salinity conditions, and continuous physicochemical and biological alterations occurring in the environment (Table 7.5).

A comparative review of butyltin compounds in different coastal regions around the globe has been presented in Table 7.6. The extreme heterogeneity of butyltin

Table 7.4 Concentration of MBT, DBT, and TBT content in sediments (expressed in $\text{ng g}^{-1} \text{dw}$) from 16 sample stations of coastal sediments of Hugli River and Indian Sundarban mangrove wetland

Sampling stations	[MBT]	[DBT]	[TBT]	BDI = ([DBT] + [MBT])/[TBT]
Barrackpore	14.8	9.2	9.6	2.50
Dakshineswar	20.3	26.4	44.7	1.04
Babughat	18.1	14.1	32.9	0.98
Bajbaj	16.0	7.7	25.9	0.92
Diamond Harbour	14.8	<d.l.	<d.l.	<d.l.
Lot 8	20.4	16.1	22.6	1.61
Ghushighata	38.5	10.7	32.8	1.50
Dhamakhali	<d.l.	<d.l.	32.4	<d.l.
Canning	22.6	7.1	22.6	1.31
Gosaba	<d.l.	<d.l.	28.9	<d.l.
Jharkhali	22.6	25.2	84.2	0.57
Kakdwip	15.9	13.5	18.4	1.60
Chemaguri	<d.l.	<d.l.	20.4	<d.l.
Bakkhali	48.0	23.3	12.3	5.80
Gangasagar	26.0	<d.l.	14.3	1.82
Haribhanga	<d.l.	<d.l.	17.9	<d.l.

d.l. detection limit ($<1.0 \text{ ng g}^{-1} \text{ d.w.}$)

Maximum values have been marked as bold

Table 7.5 BDI in sediments from different marine environments of the world

Locations	BDI	References
Australia	0.27–2.72	Burton et al. (2005)
Mediterranean coast (NE–SE Spain)	0.15–2.94	Díez et al. (2002)
Cantabria (N Spain)	5.04–11.7	Díaz et al. (2007)
Zuari estuary (India)	0–2.7	Radke et al. (2008)
The Port of Gdansk (Poland)	0.2–0.9	Jadhav et al. (2009)
Kaohsiung Harbor (Taiwan)	0.08–3.97	Chen et al. (2010)

compounds is evident which might be attributed to diverse pollution sources along with respective sediment geochemistry characteristics. The present status of sedimentary BT levels can be compared to the northwest Sicilian coast of Italy ($7.2\text{--}66.0 \text{ ng Sn g}^{-1}$) (Chiavarini et al. 2003). However, manifold high BT concentrations were recorded in Ulsan Harbor (Korea) with $55,264 \text{ ng Sn g}^{-1}$ (Kim et al. 2015) and in sediments from Kochi Harbour and Mumbai Harbour, India, with a maximum concentrations of $16,816 \text{ ng Sn g}^{-1}$ and $1193 \text{ ng Sn g}^{-1}$, respectively. However, one should keep in mind that the contamination is influenced by multiple factors, such as geographic location, anthropogenic activities, sediment geochemistry, hydrodynamic and geomorphic characters, intensity of maritime activities, etc.

Out of the three BT species, TBT generally prevailed over DBT and MBT except at stations Barrackpore, Bakkhali, and Ghushighata (Table 7.4), where MBT was

Table 7.6 Comparative account of the butyltin compounds in sediments from different regions of the world (unit expressed in ng Sn/g dry wt)

Locations	MBT	DBT	TBT	References
St. Lawrence River (Canadian)	4–989	45–997	97–888	Regoli et al. (2001)
Guanabara Bay (Brazil)	<4.7	<4.5–395	10–521	Fernandez et al. (2005)
São Paulo State coast (Brazil)	<2.77–367	14–421	<12.12–847	Godoi et al. (2003)
Scheldt estuary (the Netherlands)	16–36	16–123	45–156	Verslycke et al. (2005)
Tilbury basin (London, UK)	12–172	12–219	1–60	Scrimshaw et al. (2005)
Coast (Portugal)	<5.2–78	<5.3–65	<3.8–12.4	Díez et al. (2005)
Mediterranean coast (NE–SE Spain)	7–415	40–1790	76–4487	Díez et al. (2002)
Gipuzkoa (N. Spain)	860–2870	150–710	80–5480	Bhosle et al. (2006)
Northwest coast (Spain)	0.7–3.8	0.5–357	0.6–303	Üveges et al. (2007)
Coast (Vietnam)	<0.04–11	0.64–4.6	0.89–28	Midorikawa et al. (2004)
North coast of Kyoto (Japan)	4.3–22	2.3–23	1.2–19	Ohji et al. (2007)
Ulsan Harbour (Korea)	6212	8747	55,264	Kim et al. (2015)
Kaohsiung Harbour (Taiwan)	n.d. – 7.3	n.d. – 18.4	1.7–125	Chen et al. (2010)
Kochi Harbours (India)	n.a.	n.d. – 470	4.5–16,816	Arambarri et al. (2003)
Mumbai Harbours (India)	n.a.	n.d. – 131	4.5–1193	Arambarri et al. (2003)

predominant particularly at Bakkhali and contributed to more than 50% of total BT. This indicated that the concentration of TBT degradation product was considerable at this specific site (DBT (Sn): 23.3 ng g⁻¹ dw, MBT (Sn): 48.0 ng g⁻¹ dw), while the parent compound was present at a lower concentration (TBT (Sn): 12.3 ng g⁻¹ dw). DBT + MBT concentrations in this sample were about sixfold higher than TBT concentrations, suggesting that TBT would have been degraded. The results from this study make apparent that BT contamination is widely distributed along marine sediments in the investigated region in India. This is affected mainly by intensive use of antifouling paints to control growth of antifouling organisms on mechanized fishing boats and commercial ships along with the effluents from municipal sewage treatment plants. However, the prevalent contamination reveals lower concentrations than other coastal regions in India (e.g., Kochi Harbour, 16–16,816 ng g⁻¹, as Sn, dw, and Mumbai Harbour, 4.5–1193 ng g⁻¹, as Sn, dw, south and west coast of India, respectively). It should be noticed that

concentrations in ng g^{-1} , as Sn, are lower than those given as MBT, DBT, and TBT by a factor of ca. 0.4).

Using the pollution classification index proposed by Waite et al. (1991), the studied stations situated in the lower stretch of Hugli River, including some stations in Sundarban, may be ranked as follows: (1) medium contaminated station Jharkhali (60–200 ng g^{-1} TBT) with the highest concentration of TBT (84.2 ng g^{-1}); (2) lightly contaminated (10–50 ng g^{-1} TBT) stations Dakshineswar, Budge Budge, Babughat, Lot 8, Kakdwip, Gangasagar, Chemaguri, Haribhanga, Bakkhali, Gosaba, Canning, Ghushighata, and Dhamakhali; and (3) noncontaminated (0–10 ng g^{-1} TBT) stations Barrackpore to Diamond Harbour. According to this classification, sediments containing greater than 1000 ng g^{-1} TBT are likely to contain paint particles. The presence of DBT and MBT was indicative of TBT biotic and/or microbial degradation.

BT degradation index (BDI) is an efficient tool to assess the specific stage of TBT contamination in the aquatic system (Díez et al. 2002, 2007; Burton et al. 2005; Lee and Anderson 2005). According to previous studies, TBT degradation can be evaluated following a BT degradation index (BDI), which also assists in predicting whether BT contamination is recent or not (Díez et al. 2002). BDI is calculated by dividing the sum of DBT + MBT by TBT as expressed in the following equation:

$$\text{BDI} = \frac{([\text{DBT}] + [\text{MBT}])}{[\text{TBT}]},$$

where [MBT], [DBT], and [TBT] refer to their concentrations. Values of BDI lower than 1 indicate that BT contamination is recent, and values of BDI higher than 1 indicate that there were no recent inputs of BTs to the sediments. Thus, the calculated BDI in marine sediments considered in this estuarine environment ranged from 0.57 to 2.50, which are about the same range as those reported in the Mediterranean Region (Spain) (Díez et al. 2002) and Australia (Burton et al. 2005), as evident in Table 7.6, although sediments collected from station Bakkhali presented a higher BDI value of 5.80. The low degradation index values for sediments can be explained based on the sorption/partitioning behavior of TBT in sediment/water system. It has been reported that TBT is highly adsorbed to sediment that is fine-textured with abundant organic carbon (Burton et al. 2004), thus minimizing the bioavailable fraction amenable to degradation.

Sediments collected from stations Budge Budge, Babughat, and Jharkhali that presented a BDI lower than 1 are indicative of recent inputs of BTs. Additionally, stations, namely, Chemaguri, Haribhanga, Gosaba, and Dhamakhali, presented concentrations of TBT in the range 17.9–32.4 ng g^{-1} , while DBT and MBT were not detected in those stations, suggesting that in these stations recent inputs of BTs would have occurred or there was a low degradation rate. On the contrary, higher BDI values encountered in Bakkhali were indicative of a high degradation rate. The degradation products of BTs are far less toxic than the parent compound (Fent 1996). Degradation in aquatic system may occur step by step via debutylation of TBT to DBT and MBT, and the causative factors may be ultraviolet

(UV) photolysis and biological and chemical cleavage (Hoch 2001). It is therefore, a process by which remediation of contaminated sediments can occur involving natural attenuation processes (Burton et al. 2006; Antizar-Ladislao 2009). For seawater, UV photolysis and microbial degradation are the major degradation processes in the water column whereas exclusive anaerobic biodegradation can happen in sediments. The observed values of BTs indicate that these sediments are contaminated with BTs and at some locations the contamination appears to be high enough to produce harmful effects on marine organisms (Waite et al. 1991).

7.3.3 Ecotoxicological Concerns

The Australian sediment quality guidelines (SQGs) were considered to ascertain the potential ecotoxicological impacts for TBT present in coastal sediments in monitoring sites of the present study. The Australian SQGs reported for TBT are 12.5 and 175 ng TBT g⁻¹ for low and high trigger values (ANZECC/ARMCANZ 2000). Out of the 16 sediment samples collected from the estuarine complex of West Bengal, TBT was not detected exclusively in a solitary site of the Hooghly estuary (Diamond Harbour), and TBT concentration for other monitoring sites exceeded the high trigger value. Hence, it is evident that majority of the sampling sites, as a whole, are highly TBT contaminated and may pose a threat to benthos like high larval mortality, several malformations of shells, reduced reproduction in oysters (Alzieu et al. 1991), and growth retardation in mussels and microalgae (Salazar and Salazar 1991; Beaumont and Newman 1986).

Fine sediment particles also most readily suspended by turbulence in the overlying water; silty sediments will be involved in physical transport processes and will consequently facilitate organotin transport processes. TBT levels will be influenced by the concentrations of organic carbon, due to its lipophilic and ionic properties as endorsed by Antizar-Ladislao 2008, and, therefore, correlations with C_{org} content are expected (Garg et al. 2009). However, the existing values of correlations between the organic carbons for the marine sediments as recorded in the present study ranged from 0.04 to 1.04 (Table 7.3), and BTs were found. It is thus recommended that particular attention should be given to sites with high concentrations of TBT (Dakshineswar, Budge Budge, Babughat, Bakkhali, and Jharkhali), C_{org} values lower than 0.5% (Budge Budge, Diamond Harbour, Gangasagar, Haribhanga, and Bakkhali), and high silt content in majority of the sampling sites like Barrackpore, Dakshineswar, Budge Budge, Babughat, Diamond Harbour, Lot 8, Gangasagar, Chemaguri, Haribhanga, Jharkhali, Gosaba, Canning, Ghushighata, and Dhamakhali.

7.3.4 Alternate Booster Biocides for TBT

The most commonly used booster biocides, diuron (a broad-spectrum residual herbicide and algaecide) and Irgarol 1051 (algaecide), have been substituted for

TBT. These diverse characteristics of alternate antifouling agents are considered more persistent and stable in marine waters and sediments than other booster biocides (Zhou 2008, Thomas and Brooks 2010). Both the biocides have harmful effects on the ground of nontarget photosynthetic organisms (Guardiola et al. 2012). Due to their lethal effects on aquatic organisms even at lower concentrations and long lives, their use has already been restricted or completely banned in many affluent countries including Sweden, Denmark, France, and UK (Readman 2006; Zhou 2008; Silkina et al. 2009; Sapozhnikova et al. 2008). Recently, Kim et al. (2015) recorded diuron and Irgarol 1051 levels in sediments along with TBT from hot spots in shipping and shipbuilding regions in Korea which exceeded global sediment quality guidelines.

7.4 Conclusion

The work revealed some useful aspects related to the BT contamination in surficial sediments of the tropical estuarine environmental complex. The magnitude of contamination was consistent with the reported values previously studied from commercial harbors and marinas in global perspectives. Substantial amounts of the degraded products, DBT and MBT, were also recorded in sediments, indicating that natural attenuation is contributing to sediment remediation. Fishing using country boat at Dakshineswar, Budge Budge, Bakkhali, and Jharkhali is a matter of concern, as the concentrations found in these stations may pose harmful effects to other macro-, micro-, and meiozoobenthos, and finally these toxic compounds would enter the marine trophic chain. The site Budge Budge is of particular concern as it also presents low C_{org} values as well as high silt content which facilitates for mobilization. Thus, long-term monitoring and countermeasures to reduce the contamination levels of the compounds are recommended in this contaminated coastal regions.

References

- Adelman D, Hinga KR, Pilson MEQ (1990) Biogeochemistry of butyltins in an enclosed marine ecosystem. *Environ Sci Technol* 24:1027–1032
- Alzieu C (1998) Tributyltin: case study of a chronic contaminant in the coastal environment. *Ocean Coast Manag* 40:23–36
- Alzieu C, Michel P, Tolosa I, Bacci E, Mee LD, Readman JW (1991) Organotin compounds in Mediterranean: a continuing cause for concern. *Mar Environ Res* 32:261–270
- Antizar-Ladislao B (2008) Environmental levels, toxicity and human exposure to tributyltin (TBT)-contaminated marine environment: a review. *Environ Int* 34:292–308
- Antizar-Ladislao B (2009) Polycyclic aromatic hydrocarbons, polychlorinated biphenyls, phthalates and organotins in northern Atlantic Spain's coastal marine sediments. *J Environ Monit* 11:85–89
- ANZECC/ARMCANZ (2000) Australian and New Zealand guidelines for fresh and marine water quality. Australian and New Zealand Environment and Conservation Council/Agriculture and Resource Management Council of Australia and New Zealand, Canberra

- Arambarri I, Garcia R, Millan E (2003) Assessment of tin and butyltin species in estuarine superficial sediments from Gipuzkoa, Spain. *Chemosphere* 51:643–649
- Beaumont AR, Newman PB (1986) Low levels of tributyltin reduce growth of marine micro-algae. *Mar Pollut Bull* 17:457–461
- Bhosle NB, Garg A, Jadhav S, Harjee R, Sawant SS, Venkat K, Anil AC (2004) Butyltins in water, biofilm, animals and sediments of the west coast of India. *Chemosphere* 57:897–907
- Bhosle NB, Garg A, Harji R, Jadhav S, Sawant SS, Krishnamurthy V et al (2006) Butyltins in the sediments of Kochi and Mumbai harbours, west coast of India. *Environ Int* 32:252–258
- Burton ED, Phillips IR, Hawker DW (2004) Sorption and desorption behaviour of tributyltin with natural sediments. *Environ Sci Technol* 38:6694–6700
- Burton ED, Phillips IR, Hawker DW (2005) In situ partitioning of butyltin compounds in estuarine sediments. *Chemosphere* 59:585–592
- Burton ED, Phillips IR, Hawker DW (2006) Tributyltin partitioning in sediments: effects of aging. *Chemosphere* 63:73–81
- Canuel EA, Martens CS (1993) Seasonal variations in the sources and alteration of organic matter associated with recently deposited sediments. *Org Geochem* 20:563–577
- Chatterjee M, Filho EVS, Sarkar SK, Sella SM, Bhattacharya A, Satpathy KK, Prasad MVR, Chakraborty S, Bhattacharya BD (2007) Distribution and possible source of trace elements in the sediment cores of a tropical macrotidal estuary and their ecotoxicological significance. *Environ Int* 33:346–356
- Chen CF, Kao CM, Dong CD, Chen CW (2010) Butyltin contamination in sediments and seawater from Kaohsiung Harbour, Taiwan. *Environ Monit Assess* 169(1):75–87
- Chiavarini S, Massaniso P, Nicolai P, Nobili C, Morabito R (2003) Butyltins concentration levels and imposex occurrence in snails from the Sicilian coast (Italy). *Chemosphere* 50:311–319
- Choi M, An Y-R, Park KJ, Lee I-S, Hwang D-W, Kim J, Moon HB (2013) Accumulation of butyltin compounds in finless porpoises (*Neophocaena asiaorientalis*) from Korean coast: tracking the effectiveness of TBT regulation over time. *Mar Pollut Bull* 66:78–83
- Díaz J, Higuera-Ruiz R, Elorza J, Irabien A, Ortiz I (2007) Distribution of butyltin and derivatives in oyster shells and trapped sediments of two estuaries in Cantabria (Northern Spain). *Chemosphere* 67:623–629
- Díez S, Ábalos M, Bayona JM (2002) Organotin contamination in sediments from the Western Mediterranean enclosures following 10 years of TBT regulation. *Water Res* 36:905–918
- Díez S, Lacorte S, Viana P, Barceló D, Bayona JM (2005) Survey of organotin compounds in rivers and coastal environments in Portugal 1999–2000. *Environ Pollut* 36:525–536
- DIONEX (2001) Application note 339, determination of organotin compounds in sediments using accelerated solvent extraction (ASE® DIONEX). <http://www.dionex.com/en-us/webdocs/4489-AN339-ASE-Organotin-Sediments-08Apr2011-LPN1184-02.pdf>. Accessed 1 July 2011
- Ebdon L, Hill SJ, Rivas C (1998) Organotin compounds in solid waste: a review of their properties and determination using high performance liquid chromatography. *Trends Anal Chem* 17 (5):277–288
- Fent K (1996) Ecotoxicology of organotin compounds. *Crit Rev Toxicol* 26:3–117
- Fernandez MA, Wagener ALR, Limaverde AM, Scofield AL, Pinheiro FM, Rodrigues E (2005) Imposex and surface sediment speciation: a combined approach to evaluate organotin contamination in Guanabara Bay, Rio de Janeiro, Brazil. *Mar Environ Res* 5:435–452
- Folk RL, Ward WC (1957) Brazos River bar [Texas]; a study in the significance of grain size parameters. *J Sediment Res* 27:3–26
- Garg A, Antón-Martín R, García-Luque E, Riba I, TA DV (2009) Distribution of butyltins (TBT, DBT, MBT) in sediments of Gulf of Cádiz (Spain) and its bioaccumulation in the clam *Ruditapes philippinarum*. *Ecotoxicology* 18:1029–1035
- Garg A, Meena RM, Jadhav S, Bhosle NB (2011) Distribution of butyltins in the waters and sediments along the coast of India. *Mar Pollut Bull* 62:423–431

- Godoi AFL, Montone RC, Santiago-Silva M (2003) Determination of butyltin compounds in surface sediments from the São Paulo State coast (Brazil) by gas chromatography–pulsed flame photometric detection. *J Chromatogr A* 985:205–210
- Goldberg ED (1986) TBT: an environmental dilemma. *Environ Int* 28:17–44
- Guardiola FA, Cuesta A, Meseguer J, Esteban MA (2012) Risks of using antifouling biocides in aquaculture. *Int J Mol Sci* 13:1541–1560
- Hoch M (2001) Organotin compounds in the environment—an overview. *Appl Geochem* 16:719–743. doi:10.1016/S0883-2927(00)00067-6
- IMO, International Marine Organization (2001) International convention on the control of harmful antifouling systems on ships. http://www.imo.org/Conventions/mainframe.asp?topic_id=529. Accessed 2 Apr 2007
- Jadhav S, Bhosle NB, Massanisso P, Morabito R (2009) Organotins in the sediments of the Zuari estuary, west coast of India. *J Environ Manag* 90:S4–S7
- Kim NS, Shim WJ, Yim UH, Ha SY, An JG, Shin KH (2011) Three decades of TBT contamination in sediments around a large scale shipyard. *J Hazard Mater* 192:634–642
- Kim NS, Hong SH, An JG, Shin KH, Shim WJ (2015) Distribution of butyltins and alternative antifouling biocides in sediments from shipping and shipbuilding areas in South Korea. *Mar Pollut Bull* 95:484–490
- Krumbein WC, Pettijohn FJ (1938) *Manual of sedimentary petrology*. Appleton Century Crofts, New York, p 549
- Lee RF, Anderson JW (2005) Significance of cytochrome P450 system responses and levels of bile fluorescent aromatic compounds in marine wildlife following oil spills. *Mar Pollut Bull* 50:705–723
- Liao JF (1990) The chemical properties of the mangrove Solonchak in the northeast part of Hainan Island. *Acta Sci Nat Univ Sunyat* 9:67–72
- Luan TG, Jin J, Chan SMN, Wong YS, Tam NFY (2006) Biosorption and biodegradation of tributyltin (TBT) by alginate immobilized *Chlorella vulgaris* beads in several treatment cycles. *Process Biochem* 41:1560–1565
- Marcic C, Le Hecho I, Denaix L, Lespes G (2006) TBT and TPhT persistence in a sludged soil. *Chemosphere* 65(11):2322–2332
- Midorikawa S, Arai T, Harino H, Ohji M, Cu ND, Miyazaki N (2004) Concentrations of organotin compounds in sediment and clams collected from coastal areas in Vietnam. *Environ Pollut* 31:401–408
- Ohji M, Arai T, Midorikawa S, Harino H, Masuda R, Miyazaki N (2007) Distribution and fate of organotin compounds in Japanese coastal waters. *Water Air Soil Pollut* 178:255–265
- Olushola Sunday A, Abdullahi Alafara B, Godwin Oladele O (2012) *Oncorhynchus masou* accompanying migratory histories. *Estuar Coast Shelf S* 72:721–731. doi:10.1039/B311662J
- Qiu JW, Chan KM, Leung KMY (2011) Seasonal variations of imposex indices and butyltin concentrations in the rock shell *Thais clavigera* collected from Hong Kong waters. *Mar Pollut Bull* 63:482–488
- Radke B, Leczynski L, Wasik A, Namiesnik J, Bolalek J (2008) The content of butyl- and phenyltin derivatives in the sediment from the Port of Gdansk. *Chemosphere* 73:407–414
- Rajendran RB, Tao H, Miyazaki A, Ramesh R, Ramachandran S (2001) Determination of butyl-, octyl- and tributylmonomethyltin compounds in a marine environment (Bay of Bengal, India) using gas chromatography inductively coupled plasma mass spectrometry. *J Environ Monit* 3:627–634
- Readman JW (2006) Development, occurrence and regulation of antifouling paint biocides: historical review and future trends. In: Konstantinou I (ed) *Antifouling paint biocides. The handbook of environmental chemistry*, vol 5. Springer, Berlin/Heidelberg, pp 1–15
- Regoli L, Chan HM, de Lafontaine Y, Mikaelian I (2001) Organotins in zebra mussels (*Dreissena polymorpha*) and sediments of the Quebec City Harbor area of the St. Lawrence River. *Aquat Toxicol* 53:115–126
- Riley JP, Chester R (1971) *An introduction to marine chemistry*. Academic, London

- Rodríguez JG, Solaun O, Larreta J, Segarra MJB, Franco J, Alonso JIG, Sariego C, Valencia V, Borja A (2010) Baseline of butyltin pollution in coastal sediments within the Basque Country (northern Spain), in 2007–2008. *Mar Pollut Bull* 60:139–115
- Salazar MH, Salazar SM (1991) Assessing site-specific effects of TBT contamination with mussel growth rates. *Mar Environ Res* 32:131–150
- Sapozhnikova Y, Wirth E, Singhasemanon N, Bacey J, Fulton M (2008) Distribution of antifouling biocides in California marinas. *J Environ Monit* 10:1069–1075
- Sarkar SK, Franciscovic-Bilinski S, Bhattacharya A, Saha M, Bilinski H (2004) Levels of elements in the surficial estuarine sediments of the Hugli River, northeast India and their environmental implications. *Environ Int* 30:1089–1098
- Scrimshaw MD, Wahlen R, Catterick T, Lester JN (2005) Butyltin compounds in a sediment core from the old Tilbury basin, London, UK. *Mar Pollut Bull* 50:1500–1507
- Silkina A, Bazes A, Vouve F, Tilly VL, Douzenel P, Mouget J-L, Bourgougnon N (2009) Antifouling activity of macroalgal extracts on *Fragilaria pinnata* (*Bacillariophyceae*): a comparison with diuron. *Aquat Toxicol* 94:245–254
- Silva PV, Silva RAR, Mendo S, Loureiro S (2014) Toxicity of tributyltin (TBT) to terrestrial organisms and its species sensitivity distribution. *Sci Total Environ* 466–467:1037–1046
- Sonak S, Pangam P, Giriyan A, Hawaldar K (2009) Implications of the ban on organotins for protection of global coastal and marine ecology. *J Environ Manag* 90:S96–S108
- StatSoft, Inc. (2011) Electronic statistics textbook. StatSoft, Tulsa. <http://www.statsoft.com/textbook/>. Printed version: Hill T, Lewicki P (2007) STATISTICS methods and applications. StatSoft, Tulesa
- Stronkhorst J, Ciarelli S, Schipper CA, Postma JF, Dubbeldam M, Vangheluwe M, Brils JM, Hooftman R (2004) Inter-laboratory comparison of five marine bioassays for evaluating the toxicity of dredged material. *Aquat Ecosyst Health Manag* 7:147–159
- Szpunara J, Ceulemans M, Schmit VO, Adams FC, Łobiński R (1996) Microwave-accelerated speciation analysis for butyltin compounds in sediments and biomaterials by large volume injection capillary gas chromatography quartz furnace atomic absorption spectrometry. *Anal Chim Acta* 332:225–232. doi:10.1016/0003-2670(96)00257-7
- Thomas KV, Brooks S (2010) The environmental fate and effects of antifouling biocides. *Biofouling* 26:73–88
- Üveges M, Rodríguez-González P, García Alonso JI, Sanz-Medel A, Fodor P (2007) Isotope dilution analysis mass spectrometry for the routine measurement of butyltin compounds in marine environmental and biological samples. *Microchem J* 85:115–121
- Verslyckea T, Vethaak AD, Arijs K, Janssen CR (2005) Flame retardants, surfactants and organotins in sediment and mysid shrimp of the Scheldt estuary (The Netherlands). *Environ Pollut* 136:19–31
- Waite ME, Waldock MJ, Thain JE, Smith DJ, Milton SM (1991) Reductions in TBT concentrations in UK estuaries following legislation in 1986 and 1987. *Mar Environ Res* 32:89–111
- Walkey A, Black TA (1934) An estimation Degtijaraff method for determining soil organic matter and proposed modification of the chromic acid titration method. *Soil Sci* 37:23–38
- Zhou JL (2008) Occurrence and persistence of antifouling biocide Irgarol 1051 and its main metabolite in the coastal waters of Southern England. *Sci Total Environ* 406:239–246

Arsenic Speciation in Sediments and Representative Biota of Sundarban Wetland

8

Abstract

The case study highlights the concentration of total arsenic and individual arsenic species in four soft-bottom benthic marine polychaetous annelids of diverse feeding guilds from the intertidal regions of Indian Sundarban wetland. An additional six sites were also considered exclusively for surface sediments as this would provide important information regarding cycling of arsenic in this estuarine system. Polychaetes (*Perinereis cultrifera*, *Ganganereis sootai*, *Lumbrinereis notocirrata*, and *Dendronereis arborifera*) and the host sediments were collected adopting a standard protocol and subsequently measured for their T_{As} arsenic content using inductively coupled plasma mass spectrometry (ICP-MS). Concentration of arsenic (As) in polychaete body tissues exhibited wide range of variations, suggesting species-specific characteristics and inherent peculiarities in arsenic metabolism. Arsenic was generally present in polychaetes as arsenate (As V, ranges from 0.16 to 0.50 mg kg⁻¹) or arsenite (As III) (from 0.10 to 0.41 mg kg⁻¹) (30–53% as inorganic As) and dimethylarsinic acid (DMAV < 1–25%). Arsenobetaine (AB < 16%) and PO₄-arsenoriboside (8–48%) were also detected as minor constituents, while monomethylarsonic acid (MAV) was not detected in the polychaetes. The maximum T_{As} (14.7 mg kg⁻¹ dry wt) was recorded in the polychaete *D. arborifera* inhabited in the vicinity of a sewage outfall in which the majority of As was present as an uncharacterized compound (10.3 mg kg⁻¹ dry wt) eluted prior to AB. For host sediments, total As ranged from 2.5 to 10.4 mg kg⁻¹. The results support the importance of speciation analysis of arsenic, because of the ubiquitous occurrence of this metalloid in the environment, and its variable toxicity depending on the chemical form, present.

Keywords

Arsenic • Sediment • Bioaccumulation • Methylated arsenicals • Polychaetes • Arsenic speciation • Indian Sundarban wetland

8.1 Introduction

Arsenic is a ubiquitous semielement (metalloid) in the environment, which originated from natural as well as anthropological sources (mining activities, smelters, coal production). It ranks as the number one toxin on the US Environmental Protection Agency's list of prioritized pollutants (USEPA 1998). This is particularly alarming in India and Bangladesh due to its prevalence in groundwater, causing human health at risk for cancer and arsenicosis (arsenic poisoning) (Bhattacharya et al. 2007). Based on the aquatic environment, such as pH, redox conditions, particle texture, organic matter, etc., As can exist in four oxidation states, namely, -3 , 0 , $+3$, and $+5$ (Smedley and Kinniburgh 2002).

Identification and quantification of inorganic and organic arsenic species are essential in providing an accurate view of environmental and human health risk assessment. The behavior and bioavailability of arsenic in marine sediments are strongly influenced by its speciation which is controlled by reduction, methylation, and oxidation processes and therefore influenced by the prevailing redox conditions (Villa-lojo et al. 2006). Toxicity of arsenic appears to be strictly related to its various chemical forms or ions' inorganic (arsenite (As III) and arsenate (As V)) and organic forms (monomethyl arsenic acid (MMAA), dimethyl arsenic acid (DMAA), arsenobetaine (AB), arsenocholine (AC), trimethylarsine oxide (TMAO), tetramethylarsonium ion (TETRA) and arsenosugars).

The general interest for arsenic in the marine environment is related to the potential toxicity of this element. Inorganic arsenate (As V) and arsenite (As III) are the most toxic forms than organic species, and As III is 60 times more toxic than As V, which is 70 times more toxic than the methylated species, MMAA and DMAA. Both As III and As V are the most reactive and toxic forms, being abundant in aqueous environment. The mobility of these compounds is influenced by a set of factors such as pH, redox potential, and the presence of adsorbents such as oxides and hydroxides of Fe (III), Al (III), Mn (III/IV), humic substances, and clay minerals (Bissen and Frimmel 2003).

However, As III and As V are interconvertible in solution with oxidizing or reducing agents like KIO_3 and KI. Biological availability and physiological and toxicological effects of As depend on its valency state, and for this reason, As V is less toxic than As III. Methylated compounds such as monomethylarsonic acid (MAV), dimethylarsinic acid (DMAV), trimethylarsine oxide (TMAO), and tetramethylarsonium (TETRA) are considered moderately toxic (Phillips 1990), while more complex organoarsenic compounds like arsenobetaine (AB), arsenocholine (AC), and arsenoribosides are not harmful (Francesconi et al. 1998; Gebel 2001; Kumaresan and Riyazuddin 2001) or toxic only with high doses. Methylation of inorganic arsenic is assumed to be a process of detoxification. Thus, many organisms when exposed to arsenate are able to methylate it to mono-, di-, and trimethylated metabolites (Edmonds and Francesconi 1987). Molecular structures of some important marine arsenic species and compounds have been given in Fig. 8.1. Most importantly, a good number of unidentified organoarsenicals are set to be discovered in marine organisms.

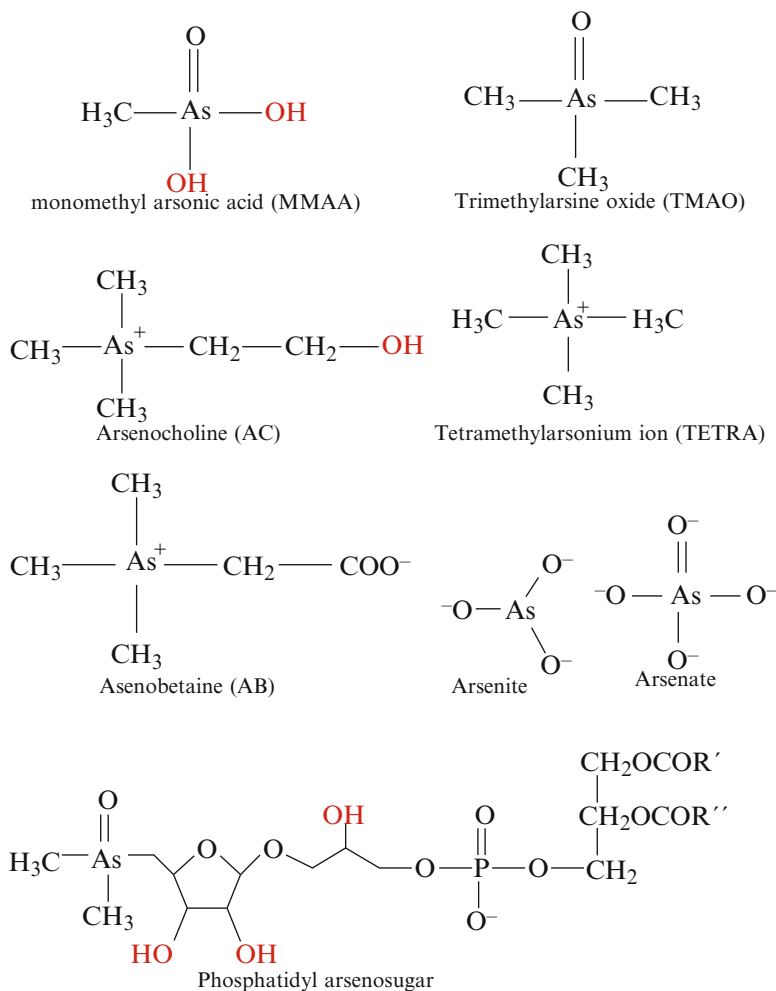

Fig. 8.1 Molecular structures of important arsenic species in marine environment

It is now well understood that speciation is essential for understanding the distribution, mobility, toxicity, and bioavailability of chemical elements in natural systems. When evaluating interactions with the environment of assessing absorption, binding mechanisms, reactivity, and excretion of the elements in humans, speciation can provide far more information than the analysis of elemental totals (Apostoli 1999). For example, As III can bind the thiol ($-\text{SH}$) group of protein, whereas As V can displace phosphate during oxidative phosphorylation and disrupt respiration. Kot and Namiesnik (2000) suggested that element speciation information is crucial for toxicity and biological activity of many elements as these depend not only on their quantities but also on their oxidation states and/or chemical forms.

For example, arsenic is extremely toxic in its inorganic forms but relatively innocuous as arsenobetaine (AB) (a common form in fish).

The purpose of the study is to improve our understanding on the distribution and chemical speciation of the toxic metalloid arsenic in benthic macrozoobenthos inhabiting in coastal regions of Indian Sundarban mangrove wetland.

8.2 Experimental Design

8.2.1 Sampling Sites

The Indian Sundarban, formed at the estuarine phase of the Hugli (Ganges), is a tide-dominated mangrove wetland belonging to the low-lying humid and tropical coastal zone. Eleven sampling sites of distinctive geographical, geomorphic, and sedimentological settings with variations of energy domains were selected covering both the eastern and western flanks of Sundarban, namely, Lower Long Sand, Gangasagar, Mayagoyalinir Ghat, Chemaguri, Gushighata and Lot 8, Kakdwip, Gosaba, Canning, Dhamakhali, and Jharkhali (as shown in Fig. 6.1). Sites Lower Long Sand to Gushighata were sampled for both polychaete and sediment collection, and sites Lot 8–Jharkhali were sampled only for sediments as they are not being inhabited by the polychaetes. The sites can be distinguished in the context of variable environmental and energy regimes of the wetland, which cover a wide range of substrate behavior, wave–tide climate, intensity of bioturbation (animal–sediment interaction), geomorphic–hydrodynamic regimes, and distances from the sea. These contrasting habitats were selected in order to explore the behavioral sensitivity of polychaete communities to diverse environmental conditions. The Lower Long Sand is an offshore island on the Bay of Bengal, and Gangasagar represents beach sediment, representing the high-energy mixing zone located at the confluence of the Hugli (Ganges) River estuary and the Bay of Bengal.

The variations of physical processes such as suspension–resuspension, lateral and vertical transport by biological activities (bioturbation), and flocculation and deflocculation of mud clasts result in a spatial variation of the substratum behavior both on local and regional scales. The sites have diverse human interferences with a variable degree of exposure to heavy metal and trace organic contamination. Moreover, the sites can be differentiated in terms of river discharge, erosion, and atmospheric deposition.

8.2.2 Polychaete and Sediment Collection

Surface sediment (up to 5 cm depth) was collected in labeled polyethylene bag using a PVC spatula, stored in iceboxes, and transported to the laboratory where they were frozen to -20°C . An aliquot of each sample was dried in a ventilated oven at low temperature (max. 45°C). Later on, they were gently disaggregated using an agate mortar and pestle, sieved through a $63\ \mu\text{m}$ metallic sieve, and stored

in hermetic plastic bags till further analyses. All visible marine debris and coarse shell fragments, sea grass leaves, and roots were isolated carefully immediately after collection. These were divided into two portions: (1) unsieved for sediment quality parameters (organic carbon, pH, sediment texture) and (2) sieved for elemental analysis.

For polychaete collection, 20 congeneric species of uniform body size were collected from each station, transported to the laboratory in acid-washed plastic containers, depurated for 2–3 days (defecation of sediments and any undigested materials), and dried to a constant weight at 45 °C. The investigated polychaete species include diverse feeding guilds as follows: *Perinereis cultrifera* (herbivore), *G. sootai* (sediment ingester), *L. notocirrata*, and *D. arborifera* (detritivores).

8.2.3 Reagents and Standards

All reagents used were analytical grade or better quality. All aqueous solutions were prepared using deionized water (18.2 MX Millipore, UK). Arsenic speciation standards and arsenoribosides are described in Watts et al. (2008) along with reagents for chromatographic separation for HPLC-ICP-MS. Phosphoric acid (Fisher Scientific, UK) and ascorbic acid (Sigma Aldrich, UK) were used for the extraction of As species from sediments. Concentrated nitric, hydrochloric, and hydrofluoric acids (Fisher Scientific, UK) were used for the dissolution of sediments and polychaetes for total arsenic analysis.

8.2.4 Total Digestion and Extraction of Sediments

Dried sediments (0.25 g) were digested in a mixed acid medium (HF, HNO₃, HClO₄) for analysis the T_{As} with the help of ICP-MS. Details of the analytical protocol were precisely provided by Watts et al. (2008). Certified reference materials were included with the sediment digestion as a measure of quality control. These were NRCC BCSS-1 and NRCC MESS-2 marine sediments, which gave good recoveries of 110 ± 12% ($n = 4$) and 92 ± 9% ($n = 4$), respectively (Table 8.2). Duplicate digestions were completed for each of the 11 sediment samples, giving mean percentage difference of 3 ± 8% ($n = 11$; ± 1 SD). Duplicate percentage difference data were largely skewed by sediments from site Lower Long Sand and Gushighata with 18 and 20%, respectively. For the other nine sediments, the mean percentage difference was 1 ± 2%.

The extraction of arsenic species from the sediments used a modified method based on the use of phosphoric acid and ascorbic acid (Gallardo et al. 2001; Garcia-Manyes et al. 2002). For chemical speciation of arsenic, the extraction process was carried out using phosphoric acid and ascorbic acid (Gallardo et al. 2001). Dried sediments (0.2 g) were weighed into 50-ml polyethylene centrifuge tubes and 10 ml of 1 M phosphoric acid and 0.5 M ascorbic acid, added and then shaken for 4 h at 200 rpm on an orbital shaker. The extracts were centrifuged at 2000 rpm for 15 min,

and the supernatant decanted into 15-ml polypropylene bottles and analyzed immediately for arsenic speciation, following an adequate dilution to minimize chromatographic distortion due to phosphoric acid. Extraction efficiency was monitored using NRCC BCSS-1 and NRCC MESS-2 marine sediments, which provided mean recoveries for the extract of $55 \pm 5\%$ ($n = 17$) and $74 \pm 8\%$ ($n = 8$), respectively (Table 8.2).

8.2.5 Total Digestion and Extraction of Polychaetes

For total As analysis, dried samples were pulverized and homogenized in a Teflon mortar and digested using microwave-assisted (CEM MARS5, CEM Corporation, UK) dissolution on 0.1 g of polychaete homogenate (dry weight). Ten milliliters of concentrated nitric acid and 100 μ l of hydrofluoric acid were added and allowed to stand for 30 min. Following an initial heating program (ramp to 100 °C over 5 min and then hold for 5 min, ramp to 200 °C over 5 min and hold for 20 min), the vessels were allowed to cool (50 °C), and then 1 ml of 30% v/v H₂O₂ was added. The vessels were sealed and microwaved for a second cycle (same program). After cooling, the sample solutions were transferred to PTFE Savellex containers and evaporated to dryness on a hotplate (100 °C) to reduce the presence of organic compounds that could form possible polyatomic interferences by ICP-MS measurement. Samples were reconstituted by the addition of 2 ml of 50% v/v nitric acid, heated at 50 °C for 30 min, and then made up to 10 ml with deionized water. This final stage reduced the dilution of the acid content required for ICP-MS measurement (2.5% v/v). The method described is a routine procedure for the dissolution of biological samples. The method accuracy was measured using CRM 627 tuna fish tissue (BCR, Brussels). Mean total arsenic recoveries of $88.9 \pm 0.01\%$ ($n = 3$; Table 8.3) were obtained, compared with the certified value. Duplicate samples provided percentage difference of less than 1%.

The extraction of arsenic species from the polychaetes followed the method described in Button et al. (2009). Homogenized dried polychaete powder (0.25 g) was weighed directly into 50-ml polyethylene centrifuge tubes which were weighed directly into 30-ml round-bottom Nalgene extraction vessels. 10 ml of methanol/water (1:1 v/v) was then added, and the tubes shaken on an orbital shaker at 175 rpm for 4 h. The extracts were centrifuged at 3000 rpm for 10 min, and the supernatant was transferred to 10-ml polypropylene bottles. The methanol was evaporated off using a rotary evaporator before freeze-drying. The freeze-dried residue was reconstituted in 10 ml of deionized water and analyzed immediately. Extraction efficiency was monitored using the CRM 627 tuna fish tissue (BCR, Brussels). A mean recovery of $108 \pm 10\%$ ($n = 3$, Table 8.3) of the total arsenic measured in the extract was obtained, comparable with Button et al. (2009) $100 \pm 6\%$. Duplicate samples provided a percentage difference of less than 1%. Duplicate digestion and extraction was only possible on two of the polychaetes owing to the lack of sample material.

8.3 Instrumentation

8.3.1 Total Arsenic Analysis

Sample digests and sample extracts were analyzed for arsenic concentrations using an Agilent 7500 ICP-MS. The standard operating conditions were as follows: RF power, 1550 W and gas flow rates – coolant, 15 l min⁻¹; auxiliary, 0.8 l min⁻¹; nebulizer, 0.85 l min⁻¹; makeup gas, 0.25 l min⁻¹; and collision cell gas He, 5.5 ml min⁻¹. An internal standard solution was added via a *t*-piece to the sample stream containing Ge, Rh, In, Te, and Ir, giving approximate signal sensitivity of greater 200 k cps.

A quaternary pump (GP50–2 HPLC Pump and an AS-50 autosampler (Dionex, USA)) was directly coupled to an ICP-MS (Agilent 7500) for the measurement of arsenic species as described in Watts et al. (2008) and O'Reilly et al. (2010). The HPLC-ICP-MS is the most common and effective coupling technique to investigate arsenic speciation in a range of biotic and abiotic matrices, due to its extreme sensitivity and selectivity. An analytical column comprising of a PRP-X100 anion exchange column (250 × 4 mm, 10 μm) and a guard column of the same material (Hamilton, USA) was connected directly to the ICP nebulizer using PEEK tubing. Chromatographic conditions utilized a gradient program using 4 and 60 mM NH₄NO₃ as described in Watts et al. (2008) and O'Reilly et al. (2010). The HPLC-ICP-MS was operated in single-ion monitoring mode at signal *m/z* 75, with a dwell time of 100 ms. The quantitative analysis of peak areas from the resultant chromatograms was performed using Agilent ICP-MS Chromatographic Data Analysis Software version B.03.06 (Agilent Technologies, UK). A series of blank solutions (deionized water) and calibration standards (1–50 μg l⁻¹ As) for each of the five arsenic species were utilized within each analytical run. The ICP-MS limit of detection for total As was 0.01 μg l⁻¹, while the LOD for each of the five arsenic species in solution by this method expressed as the mean blank signal ±3SD was As III (0.12 μg l⁻¹), As V (0.10 μg l⁻¹), MAV (0.12 μg l⁻¹), DMAV (0.15 μg l⁻¹), and AB (0.20 μg l⁻¹). Individual LODs for concentrations of As in the solid are given separately in Tables 8.2 and 8.3 for sediments and polychaetes, respectively, calculated through 3SD of the extract blanks for each analytical batch and accounting for dilution factors. Isolated arsenosugar standards were utilized for the identification of arsenosugars by retention time matching. The calibration curve of MA was used for the quantification of the phosphate, sulfonate, and sulfate arsenosugars. MA was used as an appropriate calibrant for these three arsenosugars, since it eluted within the same eluent concentration of 4 mM NH₃NO₃. Madsen et al. (2000) also used MA as a calibrant for the quantification of arsenosugars. Calibration for arsenic speciation on the sediments was performed by the standard addition of the arsenic species to the NRCC BCSS-1 marine sediment. While inorganic arsenic could be determined as As III and As V during the extraction and analytical methods, sediment speciation data will be referred to as inorganic As

(iAs), since sediment samples were dried using available drying ovens rather than by freeze-drying, hence the lack of control on interconversion from As III to As V at the first stage of sample processing (Ellwood and Maher 2003). Sediment quality characteristics (pH, organic carbon, and textural properties) were worked out by standard methods, and the detailed methodology was described in previous work (Chatterjee et al. 2007).

8.4 Results and Discussion

8.4.1 Sediment Geochemistry

Geochemical characteristics of sediments vary among them as depicted in Table 8.1. Values of pH ranged toward basic (8.0–8.6). Organic carbon content (C_{org}) values were below 1% in all the stations. The prevalent low C_{org} values are the result of sedimentation and mixing processes at the sediment–water interface where both the rate of delivery and the degradation by microbial-mediated processes can be high (Canuel and Martens 1993). Very low organic carbon content in intertidal sediments of Sundarban was recorded by previous workers, and this is related to the poor absorption capacity of organic compounds to negatively charged quartz grains, which predominate in this estuarine environment (Sarkar et al. 2004; Chatterjee et al. 2007; Domínguez et al. 2010). Textural composition showed wide range of variations from silty clay to sandy, due to typical vigorous estuarine processes such as mixing, suspension–resuspension, and flocculation–

Table 8.1 Physiochemical properties of host sediment at five sampling sites along with the description of the studied polychaete species encountered in mudflat of Sundarban wetland

Site	pH	Corg	Sand %	Silt %	Clay %	Polychaete species, family	Feeding guild
LLSand	8.6	0.15	99.7	0.3	0	<i>Perinereis cultrifera</i> , Nereididae	Herbivore, omnivorous, predator, scavenger
Gangasagar	8.2	0.2	99.3	0.7	0	<i>Ganganereis sootai</i> , Nereididae	Sediment ingester
MG Ghat	8.3	0.53	2.6	34.2	63.2	<i>Perinereis cultrifera</i> , Nereididae	Herbivore, omnivorous, predator, scavenger
Chemaguri	8.1	0.55	22.8	67.7	9.5	<i>Lumbrinereis notocirrata</i> , Lumbrineridae	Detritivore
Gushighata	8	0.57	9.4	69.8	20.8	<i>Dendronereis arborifera</i> , Nereididae	Errant polychaete dominated in the mangrove habitats; detritivore

deflocculation processes. The superparameters, namely grain size, permeability of the substratum, wave energy fluxes and hydrodynamic conditions should be considered the potential causative factors for diverse distribution pattern of this macrozoobenthos at five monitoring sites of Sundarban. These may also influence the As accumulation in the sediments (Table 8.2).

8.4.2 Arsenic in Sediments

Concentrations of T_{As} in sediments from the sampling stations ranged from 2.6 to 10.4 mg kg⁻¹ dry wt. The existing heterogeneity of T_{As} may be attributed to the particular hydrological characteristics of Sundarban wetland, which are severely influenced by southeast monsoon and the mesotidal–macrotidal regime (Bhattacharya and Sarkar 2003). Arsenic may enter the estuary through two potential sources, namely, (1) anthropogenic sources (such as effluents from multifarious industries located in the upper stretch of Hugli estuary as shown in Fig. 6.1) as well as from erosion of agricultural land in upstream region irrigated with arsenic-containing shallow waters (Islama et al. 2012) in addition to agricultural drainage and municipal and industrial discharge and (2) geogenic processes (transported by Ganges River from weathering of bed rocks in the Himalayas). These values were not particularly high compared with highly contaminated sites cited in the literature, and only three of the eleven sites exceeded the ERL of 8 mg kg⁻¹.

Three of the eleven sites exceeded the ERL of 8 mg kg⁻¹, which are indicative of levels below which adverse biological effects are rarely observed. However, in comparison, Maher et al. (2011) referred to literature concentrations of 1–4 mg kg⁻¹ As in marine sediments and 1–2 mg kg⁻¹ As in lake sediments from Australia (NSW). Whalley et al. (1999) reported As concentrations of 0.15–135 mg kg⁻¹ dry wt in North Sea sediments, Rattanachongkiat et al. (2004) 7–269 mg kg⁻¹ dry wt in sediments from Thailand, and Meador et al. (2004) 1.7–2.3 mg As kg⁻¹ and 3.9–10.4 mg kg⁻¹ dry wt in Alaskan and Californian sediments, respectively. Recently, Fang and Chen (2015) reported total As concentrations of 5.08–19.07 mg kg⁻¹ in sediments from the Danshuei Estuary, Taiwan, while high As concentrations were observed in the sediments of the Cold Lake area of Alberta, Canada, ranging from 1 to 35 mg kg⁻¹ (Javed et al. 2014). Mamindy-Pajany et al. (Mamindy-Pajany et al. 2013) found total As concentrations of 99 ± 19 mg kg⁻¹ and 11 ± 4 mg kg⁻¹, in marine sediments from French Mediterranean ports. The average arsenic concentrations were in the range of 1.6–8.6 mg kg⁻¹ dry mass in mangrove surface sediments from Australia, as reported by Hettiarachchi et al. (2016).

The maximum value of total As was recorded at Chemaguri (Table 8.1), which may be related to the location of this station at the mouth of the Baratala River estuary, infested with dense mangrove plants such as *Avicennia alba*, *A. marina*, *Nypa fruticans*, and *Rhizophora* sp. The prevalent As enrichment can be attributed to As solubilization, especially through diagenetic processes in organic-rich

Table 8.2 Concentrations (mg kg⁻¹) of As species (AB, As III, DMA, MA, As V, total As digest and extract, with % recoveries) in host sediments of polychaete species (S₁-S₅) and additional six stations (S₆-S₁₁)

Sampling sites	AB	iAs	DMA	MA	Sum As	Digest	Extract As	Extract recovery %	Recovery HPLC %	Total inorganic As %
LL-Sand (S ₁)	0.02	5.17	nd	nd	5.18	9.4	6.95	74	75	99.8
Gangasagar (S ₂)	nd	3.92	nd	nd	3.92	7.25	5.05	70	78	100
MG Ghat (S ₃)	nd	4.75	nd	nd	4.76	9.85	6.25	64	76	99.8
Chemaguri (S ₄)	nd	5.84	nd	nd	5.84	10.4	7.40	71	79	100
Gushighata (S ₅)	nd	3.32	0.02	nd	3.34	4.85	4.35	90	77	99.4
Lot 8 (S ₆)	nd	2.4	0.04	nd	2.79	2.55	1.95	77	144	86.0
Kakdwip (S ₇)	nd	3.31	nd	nd	3.31	6	4.35	72	76	100
Gosaba (S ₈)	nd	3.93	0.04	0.02	4	6.95	5.05	73	79	98.3
Canning (S ₉)	nd	3.73	0.05	nd	3.78	6.45	4.95	77	76	98.6
Dhamakhali(S ₁₀)	nd	3.65	0.06	0.01	3.72	6.05	4.65	77	81	98.1
Jharkhali (S ₁₁)	nd	4.05	0.02	0.01	4.06	6.4	5.00	79	81	99.8
BCSS-1	nd	4.8	nd	nd	4.8	7.86	5.42	55 ± 5	87 ± 10	100
MESS-2	nd	3.26	nd	nd	18.17	25.64	20.35	74 ± 8	88 ± 15	100

iAs inorganic arsenic as sum of As(III) and As(V); sample drying did not allow to discriminate between arsenite and arsenate due to oxidation
 nd not detected, LOD (mg kg⁻¹) AB, 0.02; iAs, 0.01; DMA, 0.015; MA, 0.01

mangrove sediments (Shumilin et al. 2005). Again, Gomez-Ariza et al. (2000) reported that 60–70% of arsenic is bound to Fe–Mn oxide phase in intertidal sediments. Iron, a good coprecipitator of As, has been known to be removed from the water column at river mouths as iron oxide–organic matter colloids with increasing salinity of the river water (Boyle et al. 1977).

Inorganic arsenic (iAs), both arsenate As III and arsenite As V, usually predominates in the abiotic matrices, while methylated and more complex organoarsenic compounds are generally found in tissues of living organisms, thus probably representing the final products of detoxification processes (Phillips 1990; Fattorini et al. 2008). The present findings also endorse the phenomenon where iAs exclusively predominate in the sediments (86–100%), with only a trace amount of DMA and MA in some of the samples, suggesting a relatively low biotransformation due to microorganism activity. Absolute dominance of As III in marine sediments was also recorded by Gonul (2015) in Izmir Bay (Eastern Aegean Sea) which was due to biological reduction of As V and abundance of Fe oxyhydroxides present in sediments.

The speciation results corroborated the high As levels in sediments previously recorded from intertidal mudflats of Sundarban (Chatterjee et al. 2009). This was mainly derived from untreated or semi-treated municipal and industrial discharges from multifarious industries located upstream of the Hugli (Ganges) River as endorsed by previous workers (Luoma and Cloern 1982; Moore and Ramamoorthy 1984). Moreover, being situated at the confluence of the Bay of Bengal, the Sundarban wetlands receive significant deposition of sediments from the Ganges–Brahmaputra–Meghna river system (Kuehl et al. 1989) containing several trace elements, including As at elevated concentrations (Swaine 2000). In addition, several anthropogenic sources may also involve including use of pesticides, herbicides, and fertilizers through adjacent agriculture, as well as fossil fuel burning.

A strong association of Fe and Mn in Sundarban sediments was previously recorded by Chatterjee et al. (2009), and the precipitated Fe in the form of oxyhydroxides has the affinity to scavenge other metals including As as they pass through the water to the sediments (Waldichuk 1985; Pierce and Moore 1982). Scarce information is available on arsenic compounds in marine sediments; the major compounds in the pore water of marine sediments are usually As III and As V, although methylated arsenicals (Reimer and Thompson 1988) and arsenoribosides (Ellwood and Maher 2003) have also been reported as minor constituents in sediments.

8.4.3 Arsenic in Polychaetes

Polychaetes contained measurable concentrations of As in their body tissues from 0.98 to 11.62 mg kg⁻¹, and arsenic species varied between the proportion of inorganic and organic forms (Table 8.3). The observed variations might be due to habitat and feeding differences of the polychaetes (as referred in Table 8.1) as well

Table 8.3 Concentrations (mg kg^{-1}) of As species (AB, As III, DMA, MA, As V, total As digest and extract, with % recoveries) in four polychaete species

Stations and polychaete species	AB	As III	DMA	As- PO_4	As V	Unknown	Sum As	Extract As	Digest As	Extract recovery %	HPLC recovery %
LLSand/ <i>P. cultrifera</i>	0.02	0.10	0.17	0.17	0.42	0.10	0.98	1.19	2.8	42	82
Gangasagar/ <i>G. sootai</i>	0.06	0.41	0.39	0.44	0.19	0.09	1.58	2.55	3.8	67	61
MG Ghat/ <i>P. cultrifera</i>	0.24	0.31	0.22	0.19	0.50	0.08	1.53	1.93	2.0	96	80
Chemaguri/ <i>L. notocirrata</i>	0.02	0.26	0.41	0.92	0.31	0.01	1.93	3.17	4.3	74	61
Gushighata/ <i>D. arborifera</i>	0.03	0.14	0.05	0.97	0.16	10.27	11.62	11.91	14.7	81	98
CRM627	2.94	0.04	0.11	0.01	0.03	nd	3.12	4.62	4.26	108	68

LOD (mg kg^{-1}) AB, 0.008; As III, 0.005; DMA, 0.006; As- PO_4 , 0.005; As V, 0.004

as physiological adaptation to ecological niches that probably controls bioaccumulation (Waring and Maher 2005). The elevated level of As in detritivore *D. arborifera* may be involved in the deterrence of predators (Gibbs et al. 1983). Total As recorded in the present study is at the lower range for reported marine or estuarine organisms. For example, Meador et al. (2004) found 10–100 and 2–1500 mg kg⁻¹ dw in Alaskan and Californian polychaetes, respectively. A slightly positive correlation was observed between polychaete total As tissue content and sediment C_{org}, pH, sand, and silt content ($r = 0.21, 0.43, 0.15, 0.38$, respectively; $P < 0.05$), although no correlation was apparent with clay content.

The complex animal-host interaction may vary due to the inherent characteristics of the concerned investigated species such as uptake and regulation of trace metals, digestive tract biochemistry, and physiological state and feeding preferences. In addition sediment geochemical factors (pH, C_{org}), food availability, and competition of other trace metals are also equally involved as extrinsic factors (Depledge and Rainbow 1990). The bioaccumulation process in the studied macrozoobenthos is controlled by combinations of intrinsic and extrinsic, biological, physical as well as chemical factors (Depledge and Rainbow 1990; Lee and Lee 2005; Wang et al. 1999; Wang and Fisher 1999). The values for the accumulation factor (AF) of arsenic (total arsenic concentration in polychaete body tissues/total concentration in host sediments) were generally low and did not reveal As bioaccumulation in the mortality of the polychaetes from the host sediment (*D. arborifera* from Gushighata as shown in Table 8.4), with an AF of 3.0 (range, 0.2–3.0). This is mainly concerned to the sediment-feeding of *D. arborifera* which swallows particulate organic matter, mud, sand, or plant materials, obtaining nutrients from such abiotic components and/or the fine layer of algae and/or microbes coating each particle (Hutchings 1984; Maher et al. 2011). This detrital organic material will often contain As-rich macroalgae (Waring et al. 2005). *Dendronereis arborifera* was collected from an adjacent discharge site (Gushighata) in which the polychaetes exhibited nearly 90% (11.62 mg kg⁻¹) of T_{As} as an uncharacterized As species, which eluted prior to AB and requires further characterization. About 1 mg kg⁻¹ (8%) was exhibited as a PO₄-arsenoriboside, with other As species present as minor constituents. The proportion of As in polychaetes comprised of the following: As III, 1–26%; As V, 1–43%; PO₄-arsenoriboside, 8–48%; DMA, 1–25%; and AB, <1–16%, although the latter was mainly present at 0.1 mg kg⁻¹. The median As (38%) and organo-As (62%) proportions are representative of uptake from anaerobic muddy sediments, with *D. cultrifera* (Lower Long Sand and Mayagoyalinir Ghat) exhibiting a greater proportion of As as iAs. *G. sootai* (sediment ingester), *L. notorciratta*, and *D. arborifera* (detritivores) exhibited organo-As greater than 60% compared with less than 50% for *D. cultrifera* (herbivore). The unusually high proportion of iAs (both arsenite and arsenate) was also reported by Casado-Martinez et al. (2010) in the deposit-feeding polychaete *A. marina* defined using radiotracer techniques. Recently, Casado-Martinez et al. (2012) revealed that arsenic bioaccumulation in *A. marina* was stored in the cytosol as heat-stable protein (50%), including metallothioneins, possibly as As (III)–thiol complexes. The presence of a high

Table 8.4 Concentration (mg kg^{-1}) of polychaetes versus host sediment and accumulation factor (AF)

Polychaetes		Sediments	AF
LLSand/ <i>P. cultrifera</i>	2.8	9.4	0.3
Gangasagar/ <i>G. sootai</i>	3.8	7.3	0.5
M G Ghat/ <i>P. cultrifera</i>	2.0	9.9	0.2
Chemaguri/ <i>L. notocirrata</i>	4.3	10.4	0.4

percentage (56–79%) of iAs in body tissues in *P. cultrifera* suggests they have developed a physiological resistance to these or metabolically process it (i.e., compartmentalize it) to reduce its toxicity (Waring et al. 2005). However, the proportion should be viewed in context with the low concentrations of total As found in this study.

The pattern of arsenic compounds in the studied polychaetes has several unusual features. First, AB is present as only a minor constituent (median 2%). Marine animals usually contain AB as their main compound (Francesconi and Edmonds 1997), and there have been very few reported exceptions, for example, the sea squirt *Halocynthia roretzi* (Shiomi et al. 1983). Waring et al. (2005) reported *Notomastus estuarius* to contain only 9% AB, 30% As III, 8% As V, 30% arsenoribosides, and 4% unknown anionic species. Most polychaetes accumulate AB, with the exception of deposit feeders inhabiting estuarine mud habitats, in which significant proportions of As may be present as iAs and arsenoribosides that may be metabolized differently in higher organisms compared with AB.

Organo-As compounds were reported to be accumulated by detritivore polychaetes as in Gushighata, whereby bioaccumulation for iAs is limited, particularly in relation to salinity, whereby As V is less bioavailable to marine than to estuarine animals. Organo-As compounds in marine organisms are often thought to represent nontoxic end products in a scheme for detoxifying harmful inorganic arsenic (Edmonds and Francesconi 1987). Little of the organo-As accumulated by humans from seafood is converted to toxic As III, and therefore, marine As represents a low risk to humans (Maher et al. 2011). In contrast, As V is the most toxic of the arsenic species found in environmental samples (Neff 1997); its presence as a significant arsenic species in polychaetes suggests that these organisms may have a particular resistance to As V or metabolizes it in a unique manner. The third point of interest is the presence of DMA and PO_4 -arsenoriboside as the most dominant organoarsenicals. The higher concentration of DMA in *G. sootai* (at Gangasagar) (0.39 mg kg^{-1}) and *L. notocirrata* (at Chemaguri) (0.41 mg kg^{-1}) might be related to degradation products of AB in sediments (Hanaoka et al. 1992a, b, 1996). The PO_4 -arsenoriboside contained almost 1 mg kg^{-1} in each of these polychaetes, representing 21 and <1% of total As, respectively. The fourth point is the presence of an unknown compound in all polychaete tissues in negligible amounts in each polychaete, with the exception of Gushighata (*D. arborifera*), which might be derived from the host sediments. The chemical form of this arsenic compound is currently under investigation following fresh collection of sample material.

Enrichment of AB (0.24 mg kg^{-1} dw, 16%) was encountered in *P. cultrifera* at MG Ghat in comparison to other studied species where the concentration of AB in

sediments was 0.01 mg kg^{-1} . It is unlikely that these polychaete species accumulated AB directly from interstitial water and/or sediments since AB has been reported to be readily degraded to DMA, trimethylarsine oxide (TMAO), and inorganic arsenic under both anaerobic and aerobic redox conditions in marine sediments (Hanaoka et al. 1992a, b). Possibly AB may be accumulated in polychaete body tissue through organic food material containing AB within sediments. Methylarsenate (MA) was present only in trace amount exclusively at Gosaba (0.02 mg kg^{-1}), Dhamakhali, and Jharkhali (0.01 mg kg^{-1}); in contrast, MA was totally absent in the studied polychaetes.

DMA can be considered as relatively toxic organo-As compound for marine organisms (Fattorini et al. 2004, 2005). Notably, DMA in sediments was either absent or inconsistently present in low concentrations, whereas this was almost very much present in all polychaete body tissues. The maximum DMA concentration in sediments was recorded at site Dhamakhali (0.06 mg kg^{-1}). However, the DMA is consistently present as the most important intermediates and degradation products in all polychaetes, and the maximum concentrations were observed in *L. notocirrata* ($0.41 \text{ mg kg}^{-1} \text{ dw}$) and *G. sootai* ($0.39 \text{ mg kg}^{-1} \text{ dw}$) at sites Chemaguri and Gangasagar, respectively, confirming a rapid transformation of arsenic in these polychaetes as reported by Fattorini et al. (2005). The presence of DMA might suggest both the degradation of more complex arsenic compounds (i.e., arsenosugars) accumulated from phytoplankton algae and the methylation of inorganic arsenic usually present in abiotic matrices such as seawater and sediments (Notti et al. 2007). It was reported that the polychaete species *S. spallanzanii* from the coastal regions of Australia can produce DMA by methylating iAs or demethylating more complex arsenocompounds. Results of feeding experiments supported the species-specific function of arsenic making unpalatable to predators the more vulnerable tissues (Fattorini et al. 2004; Notti et al. 2007). A similar defensive role can be proposed for the marked accumulation of vanadium in branchial crowns of *P. littoralis*, which were also vigorously rejected by fish after tasting these tissues. Hence, the unusual prevalence of DMA could be anticipated with a possible antipredatory role for these benthic polychaetes, but further investigation is still required for confirmation.

8.4.4 Arsenic in Shellfish and Finfish

An extensive work on total arsenic and its speciation was carried out by Fattorini et al. (2013) considering selective molluscan shellfishes and finfishes of Sundarban coastal regions. In benthic bivalve mollusks (*Macoma birmanica* (mussel) (Tellinidae), *Sanguinolaria acuminata* (clam) (Psammobiidae), and *Meretrix meretrix* (clam) (Verenidae)), the elevated concentration of total As was recorded in the gills and mantle which might be attributed to the following reasons: (1) the ion exchange properties of the mucous layer covering these organs facilitate in accumulating As and (2) their direct contact with the ambient seawater giving rise to greater and faster accumulation and (3) elevated filtration rate. Among the As

compounds, arsenobetaine (AB) was the most dominant form followed by dimethylarsinate (DMA), trimethylarsine oxide (TMAO), tetramethylarsonium (TETRA), and arsenocholine (AC). In contrast, inorganic As shared a minor constituent of total As.

Among the finfishes, detritivore/herbivore species, namely, *Liza parsia* and *Liza tade*, exhibited T_{As} concentrations of 10.8 and 9.71 $\mu\text{g g}^{-1}$ dry wt with a prevalence of AB (52–67%) and TETRA (26–35%). Arsenobetaine was the predominant arsenocompound accumulated in the studied soft bivalve tissues (78.8% to 89.8%) as well as in fin muscle (53–72%). The ubiquity and predominance of AB in marine organisms have been documented in several research work with some variability depending on their feeding habits and trophic position. Higher concentrations of T_{As} were encountered in two carnivorous fishes, namely, *Harpadon nehereus* (20.62 $\mu\text{g g}^{-1}$ dry wt) and *Eleutheronema tetradactylum* (19.67 $\mu\text{g g}^{-1}$ dry wt), mostly as AB (60–72%) and AC (18–29%).

These results compiling polychaetous annelids, bivalve mollusks, and finfishes ascertain that the species differences may play a major role than environment in determining the As compounds present in the marine biota. The tetramethylarsonium ion is a common arsenic compound that can result from decarboxylation of arsenobetaine, and methylation of inorganic As is assumed to be a process of detoxification.

8.5 Conclusion

The results demonstrate the unique capacity of the representative fauna of Sundarban of diverse habitat and feeding guilds to accumulate arsenic and moderately toxic arsenic compounds that might be ascribed to species-specific characteristics and inherent peculiarities in arsenic metabolism (Fattorini et al. 2005). The role of As in polychaetes is still unknown, but one plausible reason may be related to defense mechanism against predation by accumulating high level of As and its organic compounds in their body tissues. The most interesting feature of the work relates to unusual prevalence of As III and other less innocuous compounds (such as DMA and As-PO_4), as recorded in two polychaetes, namely, the sediment ingester *G. sootai* and the detritivore *L. notocirrata*. This indicates that these two species have a certain ability of inorganic arsenic methylation, which may contribute to the detoxification process and thus needs further research. In contrast, arsenic has been accumulated as As V as the most dominant form in the herbivore *P. cultrifera* with a small quantity of DMA, suggesting a limited biomethylation capacity in this species as asserted by Geiszinger et al. (2002) in the deposit-feeding polychaete *A. marina*. In contrast, AB and TETRA are the most common arsenic species in the shellfish and finfish respectively. A detailed account of additional benthic and pelagic organisms in terms of their habitat type, food preferences, physiology, and exposure to arsenic species is essentially required for the assessment of arsenic uptake pathways and bioaccumulation through the food chain. A better understanding of bioaccumulation and biotransformation of As in marine

biota is required to explore the ecological role of this toxic metalloid in this marine macrozoobenthos.

References

- Apostoli P (1999) The role of element speciation in environmental and occupational medicine. *Fresenius J Anal Chem* 363:499–504
- Bhattacharya A, Sarkar SK (2003) Impact of over exploitation of shellfish: Northeastern coast of India. *Ambio* 32(1):70–75
- Bhattacharya P, Mukherjee AB, Bundschuh J, Zevenhoven R, Loeppert R (eds) (2007) Arsenic in soil and groundwater environment: biogeochemical interactions, health effects and remediation. Elsevier, Amsterdam
- Bissen M, Frimmel FH (2003) Arsenic—a review. Part I: occurrence, toxicity, speciation mobility. *Acta Hydrochim Hydrobiol* 31:9–18
- Boyle EA, Edmond JM, Sholkovitz ER (1977) Mechanism of iron removal in estuaries. *Geochim Cosmochim Acta* 41(9):1313–1324
- Button M, Jenkins GT, Harrington CF, Watts MJ (2009) Biotransformation of As in earthworms from a contaminated mine site. *J Environ Monit* 11:1484–1491
- Canuel EA, Martens CS (1993) Seasonal variations in the sources and alteration of organic matter associated with recently-deposited sediments. *Org Geochem* 20:563–577
- Casado-Martinez MC, Smith BD, Luoma SN, Rainbow PS (2010) Bioaccumulation of arsenic from water and sediment by a deposit-feeding polychaete (*Arenicola marina*): a biodynamic modeling approach. *Aquat Toxicol* 98:34–43
- Casado-Martinez MC, Duncan EG, Smith BD, Maher WA, Rainbow PS (2012) Arsenic toxicity in a sediment-dwelling polychaete: detoxification and arsenic metabolism. *Toxicology* 21:576–590
- Chatterjee M, Silva Filho EV, Sarkar SK, Sella SM, Bhattacharya A, Satpathy KK et al (2007) Distribution and possible source of trace elements in the sediment cores of a tropical macrotidal estuary and their ecotoxicological significance. *Environ Int* 33:346–356
- Chatterjee M, Massolo S, Sarkar SK, Bhattacharya AK, Bhattacharya BD, Satpathy KK et al (2009) An assessment of trace element contamination in intertidal sediment cores of Sundarban mangrove wetland, India for evaluating sediment quality guidelines. *Environ Monit Assess* 150:307–322
- Depledge MH, Rainbow PS (1990) Models of regulation and accumulation of trace metals in marine invertebrates. *Comp Biochem Physiol, C Comp Pharmacol Toxicol* 97:1–7
- Dom'inguez C, Sarkar SK, Bhattacharya A, Chatterjee M, Bhattacharya BD, Jover E et al (2010) Quantification and source identification of polycyclic aromatic hydrocarbons in core sediments from Sundarban Mangrove Wetland, India. *Arch Environ Contam Toxicol* 59:49–61
- Edmonds JS, Francesconi KA (1987) Transformations of arsenic in the marine environment. *Experientia* 43:553–557
- Ellwood MJ, Maher WA (2003) Measurement of arsenic species in marine sediments by high performance liquid chromatography inductively coupled plasma mass spectrometry. *Anal Chim Acta* 477:279–291
- Fang T, Chen Y (2015) Arsenic speciation and diffusion flux in Danshuei Estuary sediments, Northern Taiwan. *Mar Pollut Bull* 101(1):98–109
- Fattorini D, Alonso-Hernandez CM, Diaz-Asencio M, Munoz-Caravaca A, Panacciulli FG, Tangherlini M et al (2004) Chemical speciation of arsenic in different marine organisms: importance in monitoring study. *Mar Environ Res* 58:845–850
- Fattorini D, Notti A, Halt MN, Gambi MC, Regoli F (2005) Levels and chemical speciation of arsenic in polychaetes: a review. *Mar Ecol* 26:255–264

- Fattorini D, Notti A, Di Mento R, Cicero AM, Gabellini M, Russo A et al (2008) Seasonal, spatial and inter-annual variations of trace metals in mussels from the Adriatic Sea: a regional gradient for arsenic and implications for monitoring the impact of offshore activities. *Chemosphere* 72:1524–1533
- Fattorini D, Sarkar SK, Regoli F, Bhattacharya BD, Rakshit D, Satpathy KK, Chatterjee M (2013) Levels and chemical speciation of arsenic in representative biota and sediments of a tropical mangrove wetland, India. *Environ Sci Processes Impacts* 15:773
- Francesconi KA, Edmonds JS (1997) Arsenic and marine organisms. *Adv Inorg Chem* 44:147–189
- Francesconi KA, Goessler W, Panutrakul S, Irgolic KJ (1998) A novel arsenic containing riboside arsenosugar in three species of gastropod. *Sci Total Environ-Ment* 221:139–148
- Gallardo MV, Bohari Y, Astruc A, Potin-Gautier M, Astruc M (2001) Speciation analysis of arsenic in environmental solids reference materials by high performance liquid chromatography hydride generation atomic fluorescence spectrometry following orthophosphoric acid extraction. *Anal Chim Acta* 441:257–268
- Garcia-Manyes S, Jimenez G, Padro A, Rubio R, Rauret G (2002) Arsenic speciation in contaminated soils. *Talanta* 58:97–109
- Gebel TW (2001) Genotoxicity of arsenical compounds. *Int J Hyg Environ Health* 203:249–262
- Geiszinger AE, Goessler W, Francesconi KA (2002) The marine polychaete *Arenicola marina*: its unusual arsenic compound pattern and its uptake of arsenate from seawater. *Mar Environ Res* 53:37–50
- Gibbs PE, Langston WJ, Burt GR, Pascoe PL (1983) *Tharyx marioni* (Polychaeta): a remarkable accumulator of arsenic. *J Mar Biol Assoc UK* 63:313–325
- Gomez-Ariza JL, Sanchez-Rodas D, Giraldez I, Morales E (2000) Comparison of biota sample pretreatments for arsenic speciation with coupled HPLC-HG-ICP-MS. *Analyst* 125:401–407
- Gonul LT (2015) Chemical speciation and ecological risk assessment of arsenic in marine sediments from Izmir Bay (Eastern Aegean Sea). *Environ Sci Pollut Res Int* 24:19951–19960. doi:10.1007/s11356-015-5197-9
- Hanaoka K, Koga H, Tagawa S, Kaise T (1992a) Degradation of arsenobetaine to inorganic arsenic by the microorganisms occurring in the suspended substances. *Comp Biochem Physiol* 101B:595–599
- Hanaoka K, Koga H, Tagawa S, Kaise T (1992b) The degradation of arsenobetaine to inorganic arsenic by sedimentary microorganisms. *Hydrobiologia* 235/236(Dev. Hydrobiol. 75):623–628
- Hanaoka K, Tagawa S, Kaise T (1996) The fate of organoarsenic compounds in marine ecosystems. *Appl Organomet Chem* 6:139–146
- Hettiarachchi SR, Maher WA, Krikowa F, Ubrihien R (2016) Factors influencing arsenic concentrations and species in mangrove surface sediments from south-east NSW, Australia. *Environ Geochem Health* 39:209–219
- Hutchings PA (1984) A preliminary report on the spatial and temporal patterns of polychaete recruitment on the Great Barrier Reef. In: Hutchings PA (ed) Proceedings of 1st international polychaete conference Sydney. Limnological Society, NSW, pp 227–237
- Islama SMN, Rahmana SH, Chowdhury DA, Rahmana MM, Tareq SM (2012) Seasonal variations of arsenic in the Ganges and Brahmaputra River, Bangladesh. *J Sci Res* 4(1):65–75
- Javed MB, Kachanoski G, Siddique T (2014) Arsenic fractionation and mineralogical characterization of sediments in the Cold Lake area of Alberta, Canada. *Sci Total Environ* 500–501:181–190
- Kot A, Namiesnik J (2000) The role of speciation in analytical chemistry. *Trends Anal Chem* 19:69–79
- Kuehl SA, Hariu TM, Moore WS (1989) Shelf sedimentation off the Ganges–Brahmaputra river system: evidence for sediment bypassing to the Bengal fan. *J Geol* 17:1132–1135
- Kumaresan M, Riyazuddin P (2001) Overview of speciation chemistry of arsenic. *Curr Sci* 80:837–846
- Lee JS, Lee BG (2005) Effects of salinity, temperature and food type on the uptake and elimination rates of Cd, Cr and Zn in the Asiatic Clam *Corbicula fluminea*. *Ocean Sci J* 40:79–89

- Luoma SN, Cloern JE (1982) The impacts of waste-water discharge on biological communities in San Francisco Bay. In: Kockelman HJ, Conomos TJ, Leviton AE (eds) San Francisco Bay, use and protection. Pacific Division, AAAS, San Francisco, pp 137–160
- Madsen AD, Goessler W, Pedersen SN, Francesconi KA (2000) Characterisation of an algal extract by HPLC-ICP-MS and LC-electrospray MS for use in arsenosugar speciation studies. *J Anal At Spectrom* 15:657–662
- Maher WA, Foster SD, Taylor AM, Krikowa F, Duncan EG, Chariton AA (2011) Arsenic distribution and species in two *Zostera capricorni* seagrass ecosystems, New South Wales. *Environ Chem* 8:9–18
- Mamindy-Pajany Y, Hure C, G eret F, Galgani F, Battaglia-Brunet F, Marmier N, Rom eo M (2013) Arsenic in marine sediments from French Mediterranean ports: geochemical partitioning, bioavailability and ecotoxicology. *Chemosphere* 90:2730–2736
- Meador JP, Ernest DW, Kagley A (2004) Bioaccumulation of arsenic in marine fish and invertebrates from Alaska and California. *Arch Environ Con Tamination and Toxicol* 47:223–233
- Moore JW, Ramamoorthy S (1984) Heavy metals in natural waters. Applied monitoring and impact assessment. Springer, New York
- Neff JM (1997) Ecotoxicology of arsenic in the marine environment: a review. *Environ Toxicol Chem* 16:917–927
- Notti A, Fattorini D, Razzetti EM, Regoli F (2007) Bioaccumulation and biotransformation of arsenic in the Mediterranean polychaete *Sabella spallanzanii*: experimental observations. *Environ Toxicol Chem* 26:1186–1191
- O'Reilly J, Watts MJ, Shaw RA, Marcilla AL, Ward NI (2010) Arsenic contamination of natural waters in San Juan and La Pampa, Argentina. *Environ Geo Chem Health* 32:491–515
- Phillips DJH (1990) Arsenic in aquatic organisms: a review, emphasizing chemical speciation. *Aquat Toxicol* 16:151–186
- Pierce ML, Moore CB (1982) Adsorption of arsenite and arsenate on amorphous iron hydroxide. *Water Res* 16:1247–1253
- Rattanachongkiat S, Millward GE, Foulkes ME (2004) Determination of arsenic species in fish, crustacean and sediment samples from Thailand using high performance liquid chromatography (HPLC) coupled with inductively coupled plasma mass spectrometry (ICP-MS). *J Environ Monit* 6:254–261
- Reimer KJ, Thompson AJ (1988) Arsenic speciation in marine interstitial water. The occurrence of organoarsenicals. *Biogeochemistry* 6:211–237
- Sarkar SK, Franciscovic-Bilinski S, Bhattacharya A, Saha M, Bilinski H (2004) Levels of elements in the surficial estuarine sediments of the Hugli River, northeast India and their environmental implications. *Environ Int* 30:1089–1098
- Shiomi K, Shiagawa A, Azuma A, Yamanaka H, Kikuchi T (1983) Purification of water-soluble arsenic compounds in a flatfish *Limanda herzensteini*, sea squirt *Halocynthia roretzi*, and sea cucumber *Stichopus japonicus*. *Comp Biochem Physiol* 74:393–396
- Shumilin E, Meyer-Willerer A, Marmolejo-Rodr iguez AJ, Morton-Bermea O, Galicia-Perez MA, Hernandez E et al (2005) Iron, cadmium, chromium, copper, cobalt, lead, and zinc distribution in the suspended particulate matter of the tropical Marabasco River and its estuary, Colima, Mexico. *Bull Environ Contam Toxicol* 74:518–525
- Smedley P, Kinniburgh DG (2002) Arsenic in ground water and the environment. Chapter 11, British Geological Survey, pp 263–299
- Swaine DJ (2000) Why trace elements are important. *Fuel Process Technol* 65–66:21–33
- USEPA 1998 Method 3015A, Microwave assisted acid digestion of aqueous samples and extracts. In: USEPA Methods, pp 3015A/1–18
- Villa-lojo MC, Beceiro-Gonz alez E, Alonso-Rodr iguez E, Prada-Rodr iguez D (2006) Arsenic speciation in marine sediments: effects of redox potential and reducing conditions. 377–389. <http://dx.doi.org/10.1080/03067319708030502>

- Waldichuk M (1985) Biological availability of metals to marine organisms. *Mar Pollut Bull* 16:7–11
- Wang WX, Fisher NS (1999) Assimilation efficiencies of chemical contaminants in aquatic invertebrates: a synthesis. *Environ Toxicol Chem* 18:2023–2045
- Wang W-X, Qiu J-W, Qian P-Y (1999) Significance of trophic transfer in predicting the high concentration of zinc in barnacles. *Environ Sci Technol* 33:2906–2909
- Waring JS, Maher W (2005) Arsenic bioaccumulation and species in marine Polychaeta. *Appl Organomet Chem* 19:917–929
- Waring J, Maher W, Foster S, Krilkowa F (2005) Occurrence and speciation of arsenic in common Australian coastal polychaetes species. *Environ Chem* 2:108–118
- Watts MJ, Button M, Brewer T, Harrington CF (2008) Quantitative arsenic speciation in two species of earthworms from a former mine site. *J Environ Monit* 10:753–759
- Whalley C, Rowlett S, Bennett M, Lovell D (1999) Total arsenic in sediments from the Western North Sea and the Humber Estuary. *Mar Pollut Bull* 38(5):394–400

Abstract

Mangroves are unique halophytic biogenic community in intertidal zones grown in tropical and subtropical latitudes and frequently act as a metal biofilter in estuarine environments. These specialized evergreen plants grow in physiologically dry soil, possessing highly specialized features that make them adaptive to the stressed coastal estuarine regions, viz., pneumatophores, prop roots, salt-excreting leaves, viviparous mode of germination, etc. Mangrove habitats favor accumulation of fine-sized sediment particles and organic detritus, resulting in the entrapment of both inorganic and organic pollutants. Therefore trace metal concentration in mangrove plants along with the host sediments (rhizosediments) would be considered as a potential tool on evaluating the status of metal contamination. The present chapter highlights the potential role of mangroves in sequestering trace metals from rhizosediments considering three representatives of the genus *Avicennia*, namely, *A. officinalis* (Linnaeus) 1753, *A. marina* (Forssk.) Vierh. 1907, and *A. alba* (Blume) 1826, provided with salt-excreting glands belonging to the family Avicenniaceae in Sundarban wetland. These dominated facultative mangrove trees have specific adaptive mechanisms with a physiological, morphological, and anatomical features to alleviate toxicity of metals. However, the mechanisms of internal and outer metal detoxification of these plants are still only partially understood.

Keywords

Mangroves • Phytoremediation • *Avicennia* • Trace metals • Translocation • Bioaccumulation • Phytostabilization • Sundarban wetland

9.1 Introduction

Phytoremediation [Greek prefix “phyto” (plant), and Latin “remedium” (to correct or remove an evil) (Cunningham et al. 1996, Chaturvedi et al. 2015)] is an in situ emerging solar-driven technology that utilizes the inherent abilities of living plants and rhizosphere microorganisms for removal or transformation of the contaminated soils/sediments. This could be recognized as an eco-friendly, cost-effective method of immobilizing, stabilizing, degrading, transferring, removing, or detoxifying both inorganic (e.g., heavy metals/metalloids) and organic pollutants (e.g., organochlorine pesticides, hydrocarbons, etc.) as well as nutrients and organic matter. A detailed account of the trace metal sources and their harmful effects on plants has been shown in Table 9.1.

Plants adopt different intricate cohesive mechanisms to grow in metal-stressed environment with no adverse impact on plant growth. Some plants exclude the metals/metalloids from metabolically active sites by restricted uptake or root–shoot transfer of metals (Küpfer et al. 1999). Some other plants can tolerate high metal concentrations in their tissues through binding of metals with organic compounds, metal compartmentalization at cellular and subcellular levels, and metabolic alternations (Küpfer et al. 1999; Peng et al. 2006; Wei et al. 2005). Heavy metal tolerance in plants may be defined as the ability of plants to survive in a soil that is toxic to other plants (Macnair et al. 1999, Cai and Ma. 2003).

Hyperaccumulator plants have the efficiency in absorption of metal(loid)s by adopting certain specific mechanisms such as (1) high-affinity transport systems across the plasma membranes, (2) roots growing efficiently in the metal-stressed regions, and (3) developing dense root systems with intricate fine roots helping a large surface area to absorb metals in metal-contaminated soils/sediments. They absorb metals adopting the following successive steps: (1) adsorption and transportation of metals across the membrane of roots cells, (2) loading the metals into the xylem and translocation to the aerial organs (shoots), and (3) metal detoxification within plant tissues, preferably in the epidermis, trichomes, and cuticles (Yang et al. 2005).

Previous investigations have highlighted on heavy metal pollution from diverse anthropogenic activities in mangrove environments, including domestic sewage discharge, runoff, shipping, manufacturing, and storm water discharge (Golestaninasab et al. 2014; Balakrishnan et al. 2017). Recently, Chai et al. (2017) asserted that the growth of mangrove species (*Kandelia obovata*, *Avicennia marina*, and *Sonneratia caseolaris*) may alter the sediment environment and influence the ecological risk posed by heavy metals (Zn) due to the changed concentrations.

The Indian Sundarban is the luxuriant mangrove forest, famous for being the home of 28 major mangrove species (Mandal and Naskar 2008). This anthropocene megadelta, formed at the estuarine phase of the Hooghly River, experiences domestic, industrial, as well as agricultural runoff along with rapid urban development, port activities, and tourism. Different organic and inorganic pollutants are deposited in this region affecting the local biota. Mangroves in Sundarban are being

Table 9.1 Anthropogenic sources of trace metals in the environment and their harmful effects on plants

Trace metal	Common source	Effect on plants in excess
Cd	Paints and pigments, plastic stabilizers, electroplating, incineration of cadmium-containing plastics, phosphate fertilizers. (Salem et al. 2000; Pulford and Watson 2003)	Chlorosis, growth inhibition, browning of root tips (Nagajyoti et al. 2010)
Co	Use of animal manure, detergents (Verkleij 1993, Angino et al. 1970).	Phytotoxicity, restricted concentration of Fe, Chlorophyll, protein and catalase activity (Nagajyoti et al. 2010)
Cr	Tanneries, steel industries, fly ash (Khan et al. 2007)	Effect on seed germination, root growth, and photosynthesis (Nagajyoti et al. 2010)
Cu	Pesticides, fertilizers (Khan et al. 2007)	Cytotoxic stress, growth retardation, and leaf chlorosis (Lewis et al. 2001)
Fe	Weathering of rock, burning of coal, oil, municipal wastes (Verkleij 1993, Nagajyoti et al. 2010)	Cell membrane, DNA and protein damage (Arora et al. 2002, de Dorlodot et al. 2005)
Mn	Municipal wastewater discharge, sewage sludge, emissions generated during alloy, steel and iron production, and to a lesser extent by emissions from the combustion of fuel additives (Moore 2012; Jaques 1987)	Reduction in photosynthetic rate, chlorophyll synthesis inhibition, necrosis of leaves (Nagajyoti et al. 2010)
Ni	Galvanized, paint, and powder batteries processing units (Joshi 2007)	Chlorosis, necrosis (Nagajyoti et al. 2010)
Pb	Aerial emission from combustion of leaded petrol, battery manufacture, herbicides and insecticides (Thangavel and Subbhuraam 2004, Wuana and Okieimen 2011)	Growth retardation, inhibition of seed germination (Nagajyoti et al. 2010)
Zn	Widely used in industry to make paint, rubber, dye, wood preservatives, and ointments and electroplating industries (Joshi 2007)	Phytotoxicity, inhibition of metabolic functions, retarded growth, senescence (Nagajyoti et al. 2010)

increasingly prone to trace metal pollution mostly due to their unique location in the Gangetic delta receiving pollutants from point and nonpoint sources, especially from the upstream highly urbanized region of the Hooghly estuary (see Figs. 2.1 and 6.1) as well as from the Bay of Bengal. Due to the formation of cyclones in the central Bay of Bengal, this area faces frequent natural disasters which directly help in pollutant dispersion in this fragile ecosystem (Bhattacharya et al. 2014). To mitigate this problem, phytoremediation could be considered as a potential tool. Mangrove plants, which are woody and halophytic in nature, encounter extreme natural conditions and are noted for absorbing different types of inorganic contaminants mainly from rhizosediments (Harbison 1986). Limited research on the trace element

absorption and accumulation capacity of mangrove plants in the Indian Sundarban has been conducted so far (Chowdhury et al. 2015, 2016, 2017; Chakraborty et al. 2013, Gupta and Chakrabarti 2013). The chapter exclusively devotes to explore the efficiency of a specific group of mangrove plants with the following objectives: (1) to assess the trace element accumulation ability of individual organs in mangroves belonging to the genus *Avicennia*, (2) to investigate the transport and accumulation strategies of trace elements (Cd, Co, Cr, Cu, Fe, Mn, Ni, Pb, and Zn) from rhizosediments to individual mangrove organs, and (3) to identify a potential plant candidate for phytoremediation of trace elements.

9.2 Techniques of Phytoremediation

The mechanisms and efficiency of phytoremediation depend on the type of contaminant, bioavailability, and soil properties (Cunningham and Ow 1996; Laghlimi et al. 2015). There are several ways by which plants clean up or remediate contaminated sites. The uptake of contaminants in plants occurs primarily through the root system, in which the principal mechanisms for preventing toxicity are found. The root system provides an enormous surface area that absorbs and accumulates water and nutrients essential for growth along with other nonessential contaminants (Raskin and Ensley 2000). The present study discusses about five phytoremediation mechanisms by which plants can affect contaminant mass in soil, sediments, and water. Each of these mechanisms will have an effect on the volume, mobility, or toxicity of contaminants, as the application of phytoremediation is intended to do (EPA 2000).

Phytoremediation can be classified into different applications, such as (1) phytofiltration/rhizofiltration, (2) phytostabilization, (3) phytovolatilization, (4) phytodegradation (Long et al. 2002), and (5) phytoextraction (Jadia and Fulekar 2009).

9.2.1 Phytoextraction

This is an ideal and advanced form of phytoremediation (also called phytoaccumulation) for removing pollutants from abiotic matrices (water, soil, or sediments) for a large area without adversely affecting the properties of the ambient medium. Most conveniently, metals accumulating in the harvestable plant organs can be simply restored from the ash, produced after drying, ashing, and composting their harvestable parts and thus are ecologically and economically beneficial too. Hence, this has commercial application in the mineral industry producing metals by cropping (Sheoran et al. 2009). Metal-extracting plants absorb metals from the sediment/rhizosediment, transport, and concentrate them in aerial plant organs, which are harvested and can be safely processed for disposal or recycling of metals (Ali et al. 2013). Phytoextraction process seems to be very slow and the metal-

accumulating plants are, in general, fast growing with the potential to produce high biomass.

Hence the ability to accumulate large amounts of metals in the aboveground tissues with a high biomass is a prerequisite condition for successful phytoextraction.

Thus, it refers to the uptake/absorption and translocation of metal contaminants in the soil by plant roots into the aerial portions (shoot) of the plants. Phytoextraction is primarily used for the treatment of contaminated soils (USEPA 2000). Although phytoextraction can be useful for the cleanup of slightly polluted soils, it is not a time-efficient technology for heavily polluted areas (Zhao et al. 2003). An adequate approach for these sites with high burdens of multiple elements is phytostabilization by means of species with high resistance to the multiple adverse physical and chemical factors taking place in the spoil heaps (Ernst 2005). Therefore, the establishment of an adequate vegetation cover can fulfill the objectives of stabilization, pollution control, visual improvement, and removal of threats to human health (Freitas et al. 2004). As a consequence, plants for phytostabilization should efficiently exclude the potentially toxic elements from the shoots so that their transfer in the food chain is hampered.

To remove contamination from the soil/sediments, this approach uses plants to absorb, concentrate, and precipitate toxic metals from contaminated soils into the aboveground biomass (shoots, leaves, etc.). Discovery of metal hyperaccumulator species demonstrates that plants have the potential to remove metals from contaminated soils (Raskin and Ensley 2000). A hyperaccumulator is a plant species capable of accumulating 100 times more metal than a common non-accumulating plant (UNEP, Undated), adopting several accumulation strategies. Metals such as nickel, zinc, and copper are the best candidates for removal by phytoextraction because it has been shown that they are preferred by a majority of plants (approximately 400) that uptake and absorb unusually large amounts of metals. There are several advantages of phytoextraction. The cost of phytoextraction is fairly inexpensive when compared to conventional methods. Another benefit is that the contaminant is permanently removed from the soil. In addition, the amount of waste material that must be disposed of is substantially decreased (up to 95%) (USEPA 2000), and in some cases, the contaminant can be recycled from the contaminated plant biomass. The use of hyperaccumulator species is limited by slow growth, shallow root system, and small biomass production. In addition, the plant biomass must also be harvested and disposed of properly, complying with standards (Raskin and Ensley 2000). There are several factors limiting the extent of metal phytoextraction referred as follows:

- (a) Metal bioavailability within the rhizosphere
- (b) Rate of metal uptake by roots/pneumatophores
- (c) Proportion of metal “fixed” within the roots
- (d) Rate of xylem loading/translocation to shoots
- (e) Cellular tolerance to toxic metals/metalloids

The method is also usually limited to metals and other inorganic compounds in soil or sediment (EPA 2000). In order for this cleanup method to be feasible, the plants must be equipped with the following features: (1) extract large concentrations of heavy metals into their roots, (2) translocate the heavy metal into the surface biomass, and (3) produce a large quantity of plant biomass. In addition, remediative plants must have mechanisms to detoxify and/or tolerate high metal concentrations accumulated in their shoots (Brennan and Shelley 1999). The success of this process is mainly concerned with identification of suitable hyperaccumulator plant species and large biomass.

9.2.2 Rhizofiltration

This is primarily used to remediate extracted groundwater, surface water, and wastewater with low contaminant concentrations. It is the adsorption or precipitation onto plant roots or absorption of contaminants in the solution surrounding the root zone. This is typically exploited in groundwater (either in situ or extracted), surface water, or wastewater for removal of metals or other inorganic compounds (EPA 2000). Rhizofiltration can be used for Pb, Cd, Cu, Ni, Zn, and Cr, which are primarily retained within the roots (USEPA 2000). It is similar to phytoextraction, but the plants are used primarily to address contaminated groundwater rather than soil. The plants to be used for cleanup are raised in greenhouses with their roots in water rather than in soil. The advantages associated with rhizofiltration are the ability to use both terrestrial and aquatic plants for either in situ or ex situ applications. Another advantage is that contaminants do not have to be translocated to the shoots. Thus, species other than hyperaccumulators may be used. Terrestrial plants are preferred because they have a fibrous and much longer root system, increasing the amount of root area (Raskin and Ensley 2000). Disadvantages and limitations include the constant need to adjust pH, and plants may first need to be grown in a greenhouse or nursery; there is periodic harvesting and plant disposal; tank design must be well engineered; and a good understanding of the chemical speciation/interactions is needed. The cost of remediation by rhizofiltration has been estimated to be \$2–6 per 1000 gallons of water (USEPA 2000).

9.2.3 Phytovolatilization

This involves the use of green plants to take up contaminants from the soil, transforming them into volatile forms (such as mercury, selenium) and transpiring them into the atmosphere (USEPA 2000). Phytovolatilization also involves contaminants being taken up into the body of the plant, but then the contaminant, a volatile form thereof, or a volatile degradation product is transpired with water vapor from leaves (EPA 2000). Phytovolatilization may also entail the diffusion of contaminants from the stems or other plant parts that the contaminant travels through before reaching the leaves (Raskin and Ensley 2000). Phytovolatilization

can occur with contaminants present in soil, sediment, or water. Mercury is the primary metal contaminant that this process has been used for. It has also been found to occur with volatile organic compounds, including trichloroethene, as well as inorganic chemicals that have volatile forms, such as selenium and arsenic (EPA 2000). The advantage of this method is that the contaminant, mercuric ion, may be transformed into a less toxic substance (i.e., elemental Hg). The disadvantage to this is that the mercury released into the atmosphere is likely to be recycled by precipitation and then redeposited back into lakes and oceans, repeating the production of methyl mercury by anaerobic bacteria (USEPA 2000).

9.2.4 Phytostabilization

This is also referred to as in-place inactivation, primarily used for the remediation of soil, sediment, and sludge (USEPA 2000). It is the use of certain plant species to immobilize contaminants in the soil and groundwater through absorption and accumulation by roots, adsorption onto the roots, or precipitation within the root zone of plants (rhizosphere). This process reduces the mobility of the contaminant and prevents migration to the groundwater, and it reduces bioavailability of metal into the food chain. This technique can also be used to reestablish vegetation cover at sites where natural vegetation fails to survive due to high metal concentrations in surface soils or physical disturbances to surface materials. Metal-tolerant species is used to restore vegetation at contaminated sites, thereby decreasing the potential migration of pollutants through wind erosion and transport of exposed surface soils and leaching of soil contamination to groundwater. Phytostabilization can occur through the sorption, precipitation, and complexation and takes advantage of the changes that the presence of the plant induces in soil chemistry and environment. These changes in soil chemistry may induce adsorption of contaminants onto the plant roots or soil or cause metal precipitation onto the plant root. Phytostabilization has been successful in addressing metals and other inorganic contaminants in soil and sediments (EPA 2000). Some of the advantages associated with this technology are that the disposal of hazardous material/biomass is not required, and it is very effective when rapid immobilization is needed to preserve ground and surface waters (Zhang et al. 2010). The presence of plants also reduces soil erosion and decreases the amount of water available in the system (USEPA 2000). However, this remediation technology has several major disadvantages including contaminant remaining in soil, application of extensive fertilization or soil amendments, mandatory monitoring is required, and the stabilization of the contaminants may be primarily due to the soil amendments.

9.2.5 Phytodegradation

This is also referred to as phytotransformation which involves the degradation of complex organic molecules to simple molecules or the incorporation of these

molecules into plant tissues (Trapp et al. 2001). During phytodegradation, contaminants are broken down after they have been taken up by the plant. As with phytoextraction and phytovolatilization, plant uptake generally occurs only when the contaminants' solubility and hydrophobicity fall into a certain acceptable range. Phytodegradation has been observed to remediate some organic contaminants, such as chlorinated solvents, herbicides, and munitions, and it can address contaminants in soil, sediment, or groundwater (EPA 2000).

9.2.6 Rhizodegradation/Phytostimulation

Rhizodegradation refers to the breakdown of contaminants within the plant root zone, or rhizosphere, using the plants and associated microorganisms (bacteria) to uptake, metabolize, and degrade the inorganic and organic contaminants. Studies have documented up to 100 times as many microorganisms in rhizosphere soil as in soil outside the rhizosphere (USEPA 2000). Microorganisms may be so prevalent in the rhizosphere because the plant exudes sugars, amino acids, enzymes, and other compounds that can stimulate bacterial growth. The roots also provide additional surface area for microbes to grow on and a pathway for oxygen transfer from the environment. The localized nature of rhizodegradation means that it is primarily useful in contaminated soil, and it has been found to have at least some successes in treating a wide variety of mostly organic chemicals, including petroleum hydrocarbons, polycyclic aromatic hydrocarbons (PAHs), chlorinated solvents, pesticides, polychlorinated biphenyls (PCBs), benzene, toluene, ethylbenzene, and xylenes (EPA 2000).

9.3 Advantages and Disadvantages of Phytoremediation

9.3.1 Advantages

Phytoremediation techniques tend to be more publicly acceptable, aesthetical, and less disruptive than the current physical and chemical counterparts (Tangahu et al. 2011). The main advantages of this technology involve its noninvasiveness and effectiveness in contaminant reduction, landscape restoration, low cost as it generally does not need specialized equipment or key personnel for its application (Macek et al. 2000), and the fact of being applicable for a wide range of contaminants including organic and inorganic, and overall it is an eco-friendly method (Prasad 2003; Mougín 2002). Phytoremediation is probably the cleanest and cheapest technology effectively employed in the remediation of hazardous sites and even contributes to the improvement of poor soils such as those with high metal or high salt levels (Tangahu et al. 2011), and the treated soil can be reused if the target pollutant levels are reached. Being present in relatively low concentrations with bioavailable fractions, the most common contaminants can be degraded by microorganisms which have developed numerous degradation pathways

Table 9.2 List of advantages and disadvantages of phytoremediation by green plants

S.No	Advantages	Disadvantages
1.	Bendable to a variety of organic and inorganic compounds	Restricted to sites with trivial contamination within rooting zone of remediative plants
2.	In situ/ex situ application possible with effluent/soil substrate, respectively	May take up to some years to remediate a contaminated site
3.	In situ applications decrease the amount of soil disorder compared to conventional methods	Restricted to sites with low contaminant absorptions
4.	Reduces the amount of waste to be soil filled (up to 95%), can be further employed as bio-ore of heavy metals	Harvested plant biomass from phytoremediation may be classified as a dangerous waste; hence, disposal should be proper
5.	In situ applications decrease spread of contaminant via air and water	Climatic states are a limiting factor
6.	Does not need expensive equipment or highly specialized personnel	Introduction of nonnative species may affect bio-mixture
7.	In large-scale applications, the prospective energy stored can be utilized to create thermal energy	Utilization/operation of contaminated plant biomass is a cause of concern
8.	Comparatively low cost	Elongated remediation moment

Sources: Susarla et al. (2002) and Kamath et al. (2004)

(Table 9.2). On the contrary, aging of the pollutant seems to limit biodegradation, and the availability is reduced (Mougin 2002). Therefore, consortia between microorganisms and plants might be an asset given that where one's ability is impaired, the other could help.

9.3.2 Disadvantages

The main drawback of the methodology can be ascribed as follows: (1) long time to regulate the contamination levels due to slow growth of plants, (2) the poor efficiency in contaminant removal being present at low bioavailability, and (3) inability of the roots to reach the contaminated at considerable depths, as the remediation is site-specific and for each case involves numerous interdependent variables (plant species, soil/sediment and its characteristics, concentration variations and depth of contaminants, etc.). Commercial applications of phytotechnologies are being hindered by the perception that it might require an excessive amount of time to be effective (Paquin et al. 2002; Prasad 2003) (Table 9.2). However, this can be countered if the minimal risk to the environment during the operation contrary to the use of conventional technologies is being demonstrated where the risk of contamination by leaching can be high (Robinson et al. 2003). The limitations of phytoremediation are that the contaminants below

the rooting depth cannot be extracted by the plant root system (Suresh and Ravishankar 2004). Of course the methodology can become an integral part of environmental management and risk reduction in a global scale (Prasad 2003; Reeves 2003; Dushenkov 2003), but further research is required to explore the complex phytoremediation technologies, especially in tropical regions (Dushenkov 2003).

9.4 Important Criteria for Trace Metal Accumulation in Plants

Plants have an inherent capacity to absorb metals and other trace organics from the ambient medium without showing any adverse effect. Specifically hyperaccumulators can accumulate higher amount of metals (100 times more than the average plants), sometimes exceeding the toxic levels (Baker et al. 2000; Barceló and Poschenrieder 2003; Zhou and Song 2004) and thus receiving a great deal of attention. To clean up a metal-contaminated site, scientific use of hyperaccumulator plants is a recent trend and widely used by researchers (Sun et al. 2007, 2009). The unique characteristics of a hyperaccumulator plants are as follows: (1) superb accumulating capability, (2) high tolerance capability (3) removal efficiency based on plant biomass, (4) bioconcentration factor (BCF) index, and (5) translocation factor (TF) index.

- (a) The main criteria for a plant have natural accumulation capacity of metals in their aerial parts (the threshold concentration). The values can be higher than 100 mg kg^{-1} for Cd (Zhou and Song 2004; Soleimani et al. 2010); 1000 mg kg^{-1} for Cu, Cr, Pb, and Co; 10 mg kg^{-1} for Hg (Baker et al. 2000); and $10,000 \text{ mg kg}^{-1}$ for Ni and Zn (Lasat 2002).
- (b) The ability of plants to grow in heavy-metal-contaminated sites without showing any adverse effects is called tolerance capability, e.g., chlorosis, necrosis, whitish-brown color, or reduction in the aboveground biomass (Sun et al. 2009).
- (c) Characteristics of contaminants play an important role in the phytoremediation efficiency, and the action of plants is quite different in aged compared to freshly polluted soil/sediments.
- (d) Removal efficiency based on plant biomass is the total concentration of metal and dry biomass of plants compared to the total loaded metal in the growth media (Soleimani et al. 2010).
- (e) To measure the hyperaccumulation capacity of plants, BCF index is a useful tool which is a ratio of heavy metal concentration in plant roots to that in the soil (Yoon et al. 2006). Cluis (2004) observed that $\text{BCF} > 1$ indicates hyperaccumulation, and in cases, the value may rise up to 100.
- (f) The ration of heavy metal concentration in aerial organs to that in the roots is expressed as translocation factor (Mattina et al. 2003; Liu et al. 2010). $\text{TF} > 1$ values indicate more accumulation of metal in aerial parts than aboveground parts. Therefore, it is a crucial criterion for phytoextraction, where aerial part

harvesting is the prime objective (Wei and Zhou 2006; Karami and Shamsuddin 2010). Plant excluders can be identified by $TF < 1$, and accumulators can be characterized by $TF > 1$ (Baker and Whiting 2002).

9.5 Material and Methods

9.5.1 Description of the Study Sites

The Indian Sundarban mangrove wetland is a tide-dominated anthropocene megadelta belonging to the low-lying coastal zone, formed at the estuarine phase of the Hooghly (Ganges) River as shown in Fig. 6.1. It is the largest single block of tidal halophytic mangrove forest in the world (Simlai and Roy 2012). Many of them are economically important (*Sonneratia apetala*, *Xylocarpus moluccensis*, *Excoecaria agallocha*, *Rhizophora* sp., *Bruguiera* sp., *Heritiera fomes*, etc., for timber production) and have medicinal values (species of *Avicennia*, *Bruguiera*, *Excoecaria*, *Heritiera*, *Rhizophora*, *Sonneratia*, etc.) or other commercial and domestic uses (*Avicennia marina*, *A. officinalis*, *Bruguiera* sp. as food; *Sonneratia caseolaris* as cosmetics; *B. gymnorrhiza*, *B. sexangula*, and *Ceriops tagal* for adhesive production, etc.) (Bandaranayake 1998). Due to the hostile nature of their habitat, the mangrove plants have undergone considerable physiological and morphological adaptations in order to thrive in such hostile environment (Silva et al. 2011) and are known to produce, as defensive stress responses. The typical, tropical geographical location of the Indian Sundarban in the northeast Bay of Bengal is prone to frequent natural catastrophic events like severe cyclonic storms (like Aila occurred in May 2009), floods, etc. A significant ecological change is pronounced in this area due to rapid human settlement, tourism and port activities, operation of mechanized boats, reclamation of land, and huge discharges of untreated or semi-treated domestic, municipal, and agricultural wastes as well as effluents from multifarious industries (jute mill, textile, tannery, thermal power, oil refinery) situated in the upstream of Hooghly carried by the rivers as well as contaminated mud disposal from harbor dredging (Bhattacharya et al. 2015). The ongoing degradation is also related to huge siltation, flooding, storm runoff, atmospheric deposition, and other stresses, resulting in changes in water quality, depletion of fishery resources, choking of river mouth and inlets, and overall loss of biodiversity (Sarkar and Bhattacharya 2003). The upstream of the Hooghly River flows through some of the most industrialized and urbanized (megacity Calcutta and Howrah) regions which make it one of the highly human-impacted rivers in India.

Eight study sites were selected covering the transition and buffer zone of Indian Sundarban based on the presence and abundance of the *Avicennia* species, namely, Dabu, Jharkhali, Lot 8, Gangadharpur, Chandanpiri, Phuldubi, Chemaguri, and Gangasagar (Fig. 6.1). These stations cover a variety of estuarine settings and represent a natural condition in terms of tidal amplitude, frequency of inundation, bank morphology, vegetation cover, and land disturbances along with

environmental gradients (especially salinity and turbidity). All these factors have cumulative impact on the heterogeneous spatial distribution of mangrove species at eight study sites.

9.5.2 Sample Collection and Preservation

Three members of family Avicenniaceae, namely, *Avicennia alba*, *A. officinalis*, and *A. marina*, were selected for the study as these three plants are common and widely distributed in Indian Sundarban. The plant species could be easily identified with the help of their morphological features like bark color (*A. marina*, yellowish brown; *A. officinalis*, whitish; *A. alba*, blackish), bark texture (*A. marina*, flakey; *A. officinalis*, smooth; *A. alba*, smooth), lamina shape (*A. marina*, lanceolate; *A. officinalis*, elliptic ovate; *A. alba*, lanceolate), lamina tip (*A. marina*, acute; *A. officinalis*, obtuse; *A. alba*, acute), flower color (*A. marina*, orange yellow; *A. officinalis*, dull yellow; *A. alba*, dull yellow), etc. (Naskar 2004). The plants have been reported for their medicinal uses (Quattrocchi 2012; Namazi et al. 2013; Sharief et al. 2014) and are important in the daily life of people of the coastal region. Leaves, trunk bark, and root/pneumatophore were taken as working samples. Trees that were taller than 1 m and have girth at breast height of more than 2 cm were taken in consideration (Chowdhury et al. 2015). Aerial and subaerial plant samples (leaf, bark, and root/pneumatophore) were detached from the tree by using a sterilized steel knife and immediately transferred in clean plastic zip lock pouches and transported to the laboratory. Individual samples were washed by deionized water in the laboratory thoroughly to remove any adhering dirt or dust particles. These were then grinded and oven-dried to constant weight under 50 °C and homogenized, adopting the methods performed by MacFarlane et al. 2003.

Surface sediment samples were collected in triplicate from top 0–5 cm from each study site covering an area of 1 m × 1 m using a clean, acid-washed fabricated polyvinyl chloride (PVC) scoop. Samples were transported to the laboratory in plastic zip lock pouches and dried in a ventilated oven at low temperature (~45 °C) (Watts et al. 2013) until constant weight. Dried samples were then homogenized and sieved (63 μm) since this fraction contains more sorbed metals per gram of sediment due to its larger specific surface area. Samples were kept aseptically in sterile polypropylene bags and stored at room temperature using silica gel as a desiccating agent. Non-sieved sample was used for other physicochemical analyses.

9.5.3 Analyses of Trace Metals in Sediments and Plants

The sediment and plant samples were prepared by microwave digestion in closed Teflon vessels (Walsh et al. 1997). The determination of total trace metal was performed using atomic absorption spectrometry (AAS, SOLAAR M Series equipment from Thermo Unicam) for Co, Cr, Cu, Fe, Mn, Ni, Pb, and Zn; coupled graphite furnace AAS for As and Cd; and a hydride generation system (HGS) linked

to an atomic absorption for Hg. The detailed analytical protocol has been described in a previous research paper from the same mangrove wetland (Chowdhury et al. 2015). To check the accuracy and precision in analyses of metals, 2711 SRM reference material (Montana Soil, from LGC Promochem, Barcelona, Spain) for sediments and CTA-VTL-2 (reference materials for tobacco leaves) for plants were also considered and analyzed in triplicate. The agreements between the certified reference values and those determined by the analytical method were in the range of 85.5–110%.

The pH and redox potential of rhizosediment was measured using a glass electrode (HI 98160, HANNA Instruments, USA, Accuracy: 0.1–0.01 pH, 1 mV (± 2000 mV), 0.1 °C) by inserting the probes directly into the fresh sediment sample. The electrode was calibrated using 4.01, 7.01, and 10.01 buffer solutions (HANNA instruments, USA). Electrode was inserted for several minutes in the mud until stable values were reached and then was thoroughly washed and subsequently rubbed with fine tissue paper after each measurement in order to prevent the poisoning of electrodes by sulfide (Marchand et al. 2004). Organic carbon (C_{org}) content of the sediments was determined following a rapid titration method (Walkley and Black 1934). Analyses were done in triplicates, and the mean values were taken. Mechanical analyses of substrate sediments were done by sieving in a Ro-Tap Shaker (Krumbein and Pettijohn 1938), and statistical computation of textural parameters was done by using the formulae of Folk and Ward (1957) and following the standards of Friedman and Sanders (1978). The sand, silt, and clay fractions were measured by sieving a weighed amount of the sample in a digital balance (Adair Dutt, Model-GR 202, sensitivity drift (10–30 °C) is ± 2 ppm/°C).

9.5.4 Analysis by Scanning Electron Microscope (SEM)

To study the morphological characteristics of laminar salt glands, scanning electron microscopy (SEM) analysis was performed using Model EVO 18 special edition (Carl Zeiss Inc., Germany). Sections of dried leaf samples were placed on double-sided carbon adhesive tape secured to aluminum-alloy stubs. Prior to analysis, samples were metalized with gold coating with a sputter coater and passed through a 10 kV acceleration voltage to take photomicrographs at suitable magnifications (Fig. 9.1).

9.5.5 Statistical Analyses

The statistical analysis and the correlations between trace metals were performed by using Minitab 13. Data were analyzed using student's test (t -test) and a two-way analysis of variance. Independent variables examined with exponential accumulation relationships were log-transformed $\ln(n + 1)$ prior to statistical calculation (Minitab 13). The logarithm-transformed data were applied to eliminate the

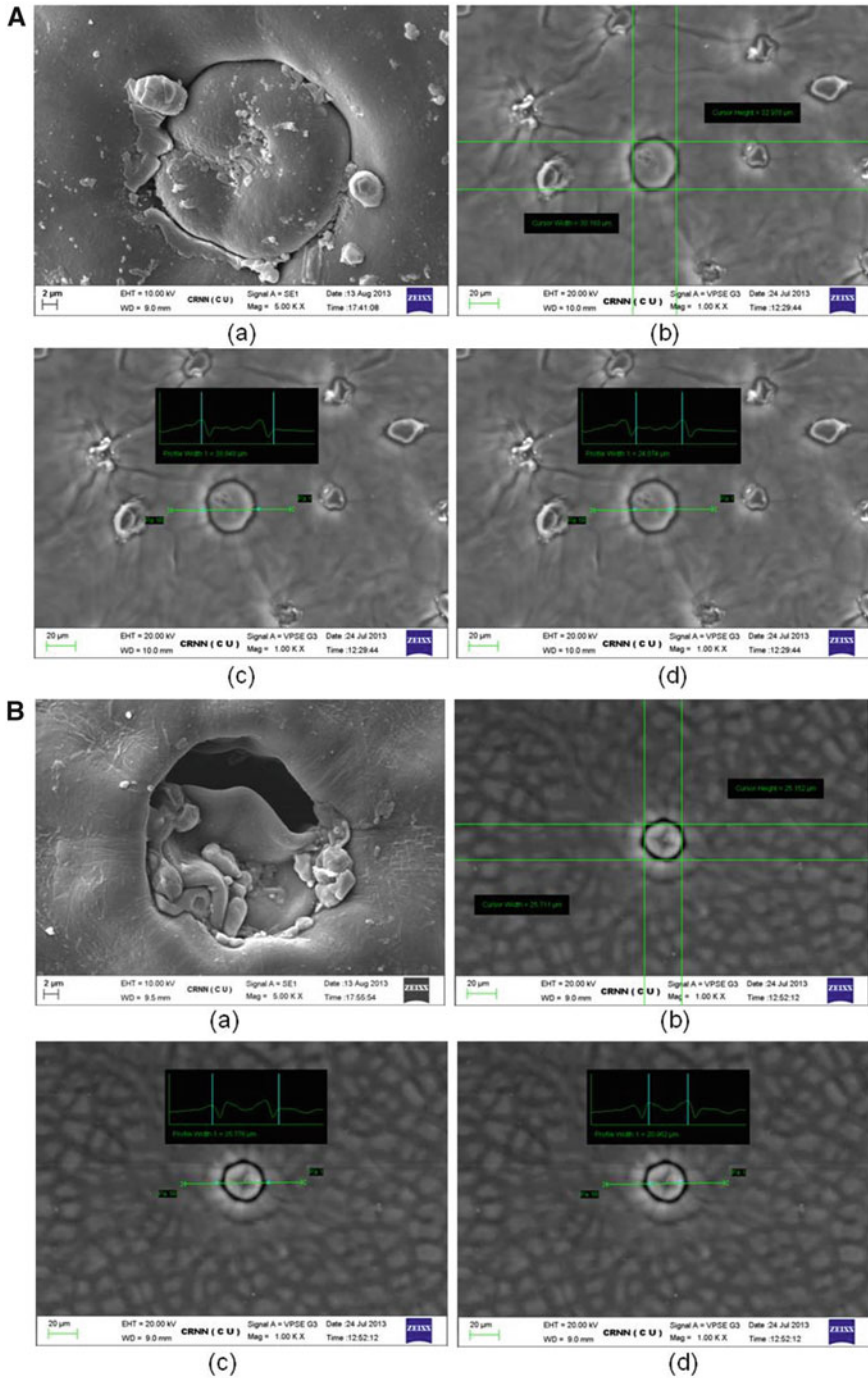

Fig. 9.1 Salt glands on the upper surface of leaves of (A) *A. officinalis*, (B) *A. marina*, and (C) *A. alba* with excreted salt crystals, each showing (a) general morphology, (b) size, (c) diameter of outer wall, and (d) diameter of inner pit

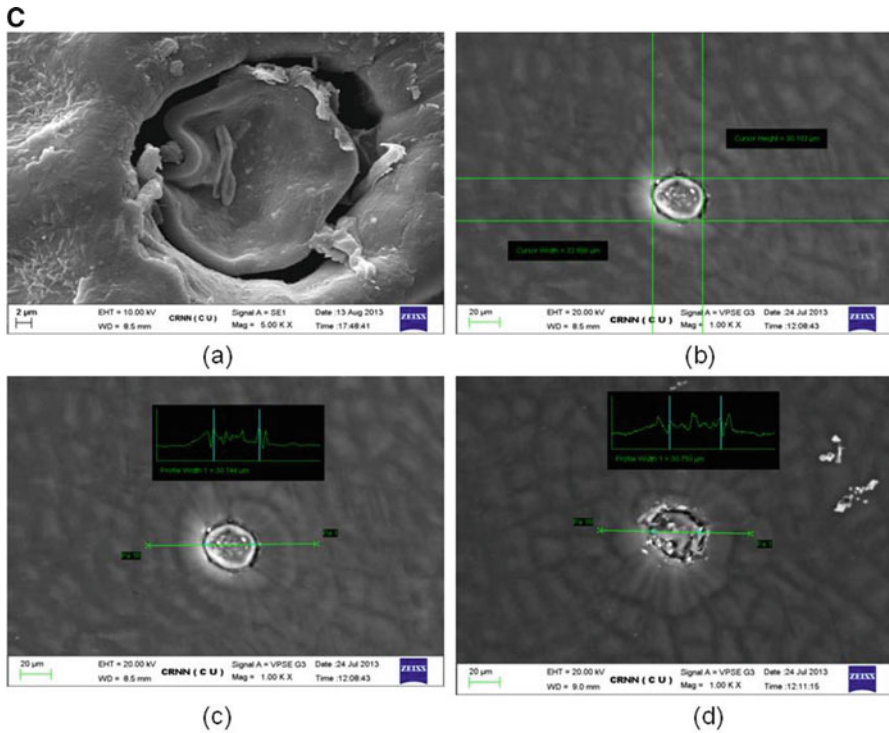

Fig. 9.1 (continued)

influence of different units of variance and give each determined variable an equal weight (Wang et al. 2013).

9.6 Results and Discussion

9.6.1 Sediment Geochemistry

The results of geochemical characterization of rhizosediments are presented in Table 9.3. Sediment showed differences in their physicochemical properties pertaining to pH, C_{org} , and textural properties. Values of pH are characterized by mild alkaline in nature (7.10–8.13) due to the limited buffer capacity of these sediments (Chowdhury et al. 2015). The organic carbon values ranged from 0.39 to 1.08%. The pH and C_{org} content in the sediments affect the availability and mobility of trace metals (Li et al. 2013) through adsorption and complexation in the aquatic environment. Sediment grain size is another controlling factor affecting the abundance of trace metals in sediment. Due to surface adsorption and ionic attraction, fine-grained sediments tend to have relatively high metal contents (Jonathan

Table 9.3 Pooled values of mean, standard deviation, median, and range of nine metals in sediments of eight study sites of Indian Sundarban along with sediment quality guideline values

	Cd	Co	Cr	Cu	Fe	Mn	Ni	Pb	Zn
Range	0.01–0.48	6.3–16.17	11.90–33.29	29.09–81.7	2367–55,946	570–1004	11.6–45.8	10.2–35.9	32.16–69.9
Median	0.21	7.22	22.53	39.16	39,181.31	826.58	39.23	15.38	37.95
Mean	0.24	8.74	21.62	45.38	33,740.77	810.06	35.47	17.92	43.01
SD	0.18	3.39	6.53	18.30	17,760.75	143.55	12.19	7.81	11.95
PEL	3.53	–	90	197	–	–	36	91.3	315
TEL	0.59	–	37.3	35.70	–	–	18	35	123
ER- L	1.2	–	81	34	–	–	20.9	46.7	150
ER- M	9.6	–	370	270	–	–	51.6	218	410

et al. 2010). In the present study, sediment samples exhibit a variable admixture of sand (0.58–26.14%), silt (15.10–42.63%), and clay (56.79–67.21%).

The trace metal data for the eight study sites (as shown in Table 9.3) indicated considerable spatial variability that may be due to proximities to the contaminant sources (Spencer and MacLeod 2002). Majority of the trace metals (except Cd and Mn) exhibited higher concentration than the plant organs. The trace metal concentration was recorded in the following descending order of (values expressed in mg kg^{-1}) $\text{Fe} > \text{Mn} > \text{Cu} > \text{Zn} > \text{Ni} > \text{Pb} > \text{Cr} > \text{Co} > \text{Cd}$. In all eight study sites, Fe content was maximum ranging from 2367.41 to 55,946.36 mg kg^{-1} , which might be due to the precipitation of Fe as FeS which is common in mangrove ecosystems. These sulfides form a major sink for trace metals under permanently reducing condition (Thomas and Fernandez 1997). Iron and Mn also shared similar distribution patterns in sediment, and their variations between stations could be associated with a set of factors such as differences in hydrodynamics, churning, erosion, bioturbation, periodic dredging activities, etc. (Sarkar et al. 2007), which are known to affect the metal concentrations in surface sediments. According to Lacerda et al. (1988), marine suspended matter with elevated metallic load is actively trapped within the tangled roots, abundant in the mangrove environment, and thus helps in elevating the trace metal levels in the sediments (Harbison 1986). The binding of settled suspended matter by tangled roots causes immobilization of trace metals and thus helps in elevating the metal levels in the rhizosediment. A synchronous elevation of all the metals at Lot 8 is a characteristic feature which might be attributed to a set of anthropogenic activities, such as use of antifouling paints and burnt oil in the country boat, use of herbicides and pesticides in adjacent agricultural fields, and intensive fishing.

9.6.2 Assessment of Sediment Quality Values

9.6.2.1 Geoaccumulation Index (I_{geo})

To assess the possible sediment enrichment of metal contamination level, geoaccumulation index (I_{geo}) was calculated using the equation formulated by Müller (1979): $I_{\text{geo}} = \text{Log}_2(Cn)/1.5(Bn)$, where Cn is the measured concentration of the examined metal (n) in the sediment and Bn is the geochemical background concentration of the metal (n). The factor 1.5 is the background matrix correction factor which includes any possible variations of the background values due to lithogenic effects (Müller 1979). The constant factor 1.5 is introduced to analyze natural fluctuations in the contents of a given substance in the environment and very small anthropogenic influences (Loska et al. 2004). As shown in Table 9.4, there are seven classes of I_{geo} (Müller 1981) ranging from Class 0 ($I_{\text{geo}} \leq 0$, uncontaminated) to Class 6 ($I_{\text{geo}} > 5$, extremely contaminated).

The I_{geo} value was either negative or lower than 1.0 for seven trace metals (except Cr and Fe) at all stations (as revealed in Table 9.5) indicating unpolluted to moderately polluted status. For Fe, I_{geo} value was 4.90 at Gangasagar indicating

Table 9.4 Pollution grades of geoaccumulation index of the metals

I_{geo} class	I_{geo} value	Pollution quality
0	$I_{\text{geo}} \leq 0$	Uncontaminated
1	$0 < I_{\text{geo}} < 1$	Uncontaminated to moderately contaminated
2	$1 < I_{\text{geo}} < 2$	Moderately contaminated
3	$2 < I_{\text{geo}} < 3$	Moderately to heavily contaminated
4	$3 < I_{\text{geo}} < 4$	Heavily contaminated
5	$4 < I_{\text{geo}} < 5$	Heavily to extremely contaminated
6	$5 < I_{\text{geo}} <$	Extremely contaminated

heavily to extremely contaminated state of sediment and 2.67 at Gangadharpur indicating moderately to heavily contaminated situation.

9.6.2.2 Enrichment Factor (EF)

To determine the possible source (natural/anthropogenic) of metal pollution and the degree of anthropogenic influence, the enrichment factor (EF) was calculated using the proposed formula of Abraham and Parker (2008):

$$EF = [(Me)_s / (Fe)_s] / [(Me)_b / (Fe)_b]$$

where $(Me)_s$ and $(Me)_b$ are the concentrations of a certain metal in samples and the background concentration of the metal, respectively; $(Fe)_s$ and $(Fe)_b$ are the concentration in samples and the background concentration of the reference metal Fe, respectively. Iron was used as a geochemical normalizing reference element due to its (1) similarity with many other trace metals, (2) uniform natural concentration, and (3) association with fine solid surfaces (Varol 2011). EF values were interpreted as suggested by Sakan et al. (2009), where $EF < 1$ indicates no enrichment, $1 < EF < 3$ is minor enrichment, $3 < EF < 5$ is moderate enrichment, $5 < EF < 10$ is moderately severe enrichment, $10 < EF < 25$ is severe enrichment, $25 < EF < 50$ is very severe enrichment, and $EF > 50$ is extremely severe enrichment (Table 9.5).

As revealed in Table 9.5, the EF values for Cd showed minor enrichment at Phuldubi (1.39), Chemaguri (1.17), and Lot 8 (1.77) and very severe enrichment (30.91) at Gangasagar. An elevated enrichment (11.42) and minor enrichment (2.04) for Co were also recorded. Both Cr and Ni showed moderate enrichment (4.90) and moderately severe enrichment (6.46) exclusively at Gangasagar. Copper showed minor enrichments at Chandanpiri (1.00), Jharkhali (1.02), and Lot 8 (1.42) and moderately severe enrichment (7.72) at Gangadharpur and severe enrichment (18.61) at Gangasagar. For Mn, minor similar trend of enrichment at Chandanpiri, Phuldubi, Chemaguri, Dabu, Gangadharpur, and Lot 8 but severe enrichment (15.22) at Gangasagar were recorded. Lead showed minor enrichment (1.11, 1.11) at Chandanpiri and Lot 8, moderately severe enrichment at Gangadharpur, and severe enrichment (10.19) at Gangasagar. Zinc showed moderate enrichment (3.09) at Gangadharpur and moderately severe enrichment (6.75) at Gangasagar.

Table 9.5 Pooled mean values of index of geoaccumulation (I_{geo}) and enrichment factor (EF) considering eight study sites of Sundarban

		Cd	Co	Cr	Cu	Fe	Mn	Ni	Pb	Zn
Dabu	I_{geo}	-1.18	-1.28	-1.54	-0.66	-0.47	-0.39	-0.73	-0.58	-1.17
	EF	0.44	0.39	0.29	0.8	1	1.09	0.74	0.88	0.45
Jharkhali	I_{geo}	-1.09	-1.16	-1.47	-0.19	-0.2	-0.26	-0.72	-0.66	-1
	EF	0.36	0.33	0.23	1.02	1	0.93	0.55	0.59	0.4
Lot 8	I_{geo}	0.06	-0.49	-1.22	-0.13	-0.44	-0.21	-0.7	-0.35	-0.91
	EF	1.77	0.94	0.41	1.42	1	1.3	0.74	1.12	0.58
Gangadharpur	I_{geo}	-3.31	-0.99	-2.11	0.166	-1.61	-0.7	-1.89	0.156	-0.63
	EF	0.14	2.04	0.56	7.72	1	2.85	0.73	7.63	3.09
Chandanpiri	I_{geo}	-1.4	-1.23	-1.49	-0.54	-0.54	-0.42	-0.87	-0.45	-1.16
	EF	0.37	0.45	0.33	1	1	1.15	0.69	1.12	0.49
Phuldubi	I_{geo}	-0.24	-1.28	-1.86	-0.73	-0.53	-0.36	-0.83	-0.64	-1.22
	EF	1.39	0.42	0.22	0.8	1	1.22	0.71	0.89	0.45
Chemaguri (S ₇)	I_{geo}	-0.36	-1.31	-1.76	-0.71	-0.5	-0.32	-0.83	-0.58	-1.14
	EF	1.17	0.39	0.23	0.78	1	1.22	0.68	0.91	0.48
Gangasagar(S ₈)	I_{geo}	0.03	-0.84	-1.57	-0.41	-2.95	-0.59	-1.33	-0.94	-1.29
	EF	30.9	11.42	4.91	18.61	1	15.22	6.46	10.19	6.75

All such high enrichment values suggest some point pollution sources for them. Intensive fishing and ferry services, sewage drainage from the mainland, and other commercial activities are supposed to be potential sources for the enrichment of these metals in study sites (Chatterjee et al. 2007).

9.6.3 Sediment Quality Guidelines (SQGs)

To learn more about the potential toxicity of sediment in aquatic ecosystems, this study employs the sediment quality criteria established by the National Oceanic and Atmospheric Administration (NOAA), specifically the TEL and PEL and the ERL and ERM, respectively (Long 2006 and MacDonald et al. 2000) (Table 9.3). The 10th percentile and the 50th percentile (median) of the effects database were identified for each heavy metal. The 10th percentile values were classified as “effects range-low” (ERL) values, and the 50th percentile values were classified as “effects range-median” (ERM) values. The ERL values are indicative of concentrations below which adverse effects rarely occur, and the ERM values are representative of concentrations above which adverse effects frequently occur (Table 9.6). The data from various similar studies were compiled for both sets of ERL and ERM values and the comparable threshold effects levels (TELs) and probable effects levels (PELs) to determine whether a specific metal detected in sediment poses a threat to aquatic ecosystems. Fewer adverse biological effects occur when sediment contaminant concentrations are below the ERL. When the concentrations are between the ERL and ERM, adverse biological effects can occasionally occur, and when they exceed the ERM, adverse biological effects occur more frequently. In this study, our results show that concentration of Cu exceeded TEL and ERL value at Jharkhali, Lot 8, Gangadharpur, Chandanpiri, and Gangasagar (Table 9.3). Major sources of Cu in Sundarban regions originated from the use of antifouling paints in boats (Usman et al. 2013) and extensive use of fertilizers and pesticides for agricultural needs. Concentration of Ni was higher than TEL and ERL at all stations, except Jharkhali, but lower than the ERM standard. Emission of smelters, burning of coal and oil, and use of phosphate fertilizers and

Table 9.6 Classification of sediment quality guidelines (SQGs) and its effects

Sediment quality guidelines	Effect	References	
TEL and PEL guidelines	<TEL	Not associated with adverse biological effects	MacDonald et al. (2000)
	TEL < PEL	May occasionally be associated with adverse biological effects	
	>PEL	Frequently associated with adverse biological effects	
ERL and ERM guidelines	<ERL	Effects would occasionally occur	Long et al. (1995)
	ERL < ERM	Effects would frequently occur	
	>ERM	Effects would frequently occur	

pesticide are contributing Ni in the riverine system. Lead crossed prescribed TEL value only at Jharkhali. Coal combustion from thermal power plants located at the industrial belt of Hooghly River, vehicle emission, and precipitation of aerosols are the important sources of Pb as endorsed by Gao and Chen (2014). Other trace metals did not exceed the guideline values, and hence no adverse effect is considered. However, apart from human-induced stresses, the local geological background and depositional settings might also be concerned for SQG exceedance (Morelli and Gasparon 2014).

9.6.4 Trace Metal Content in Mangrove Plants

The plant species exhibited different trends of accumulation for each metal, which might be due to complex physiological mechanisms of the plants and the bioavailable fraction of the metal present in the sediment. The trend of accumulation of trace metal was recorded in the following descending order (values taken in average, expressed in mg kg^{-1}): Mn (406.94 ± 534.21) > Fe (202.62 ± 193.73) > Zn (16.86 ± 11.55) > Cu (13.18 ± 6.15) > Ni (3.97 ± 2.61) > Co (2.34 ± 1.05) > Pb (1.14 ± 1.44) > Cr (1.04 ± 0.71) > Cd (0.84 ± 0.70). Majority of the trace metals were found to be accumulated in maximum concentration especially in root/pneumatophore tissue as shown in Table 9.7. This might be related to efficient role of the roots, to be considered as a poor translocator of metals, thus minimizing any adverse effect on the aerial organs (Agnello et al. 2016). Moreover, secretion of metal-chelating agents along with citric acid and oxalic acid also helps to solubilize and assimilate micronutrients from minute levels in the soil (Tam and Wong 1997), even from nearly insoluble precipitates via micropores (Hinchman et al. 1995). The maximum concentration of Fe (984 mg kg^{-1} in *A. officinalis* at Lot 8) as well as Mn (1984 mg kg^{-1} *A. officinalis* at Lot 8) recorded in the present investigation may be attributed to re-adsorption of these metals released during sulfidic oxidation onto organic matter and/or coprecipitation with Fe hydroxides (Chaudhuri et al. 2014). Formation of Fe plaques (iron-rich root coatings) on root surface formed under waterlogged anoxic conditions acts as a physical “barrier” through the immobilization and coprecipitation of trace metals and nutrients. The process is directly related to the amount of Fe plaques formed in the root surface. The structure also plays a key role in the removal and detoxification of wastewater-borne pollutants, thus protecting sensitive aerial organs of the plant from contaminants (Batty et al. 2002). Other than hyperaccumulator plant species, most plants restrict the movement of metal ions into photosynthetic tissue, by restricting metal transport across the root endodermis (stele), and removing any mobile ions in the xylem by means of storage in cell walls and vacuoles, or binding by metal-binding proteins such as metallothioneins or phytochelatins (Vesk et al. 1999; MacFarlane and Burchett 2000). Pi et al. (2011) had experimentally demonstrated that Fe plaque formed on the mangrove root with wastewater discharge and immobilization of heavy metal concentration was significantly related to the amounts of the plaques formed.

Table 9.7 Concentration of trace metals in (mg kg^{-1}) plant parts along with phytotoxic concentrations

	Cd	Co	Cr	Cu	Fe	Mn	Ni	Pb	Zn
<i>A. officinalis</i>									
Leaf	0.31 ± 0.31	1.71 ± 0.41	0.65 ± 0.26	13.49 ± 5.25	213.92 ± 129.79	736.96 ± 691.22	3.75 ± 2.66	0.89 ± 0.93	17.9 ± 5.16
Bark	0.92 ± 0.76	2.11 ± 1.41	1.03 ± 0.39	12.36 ± 5.36	319.22 ± 245.79	383.42 ± 428.84	3.21 ± 2.19	1.21 ± 1.96	14.56 ± 8.74
Pneumatophore	0.83 ± 0.48	2.71 ± 0.97	1.48 ± 1.44	13.99 ± 5.29	238.01 ± 314.11	724.24 ± 758.48	3.86 ± 3.24	1.39 ± 0.78	12.38 ± 10.11
<i>A. marina</i>									
Leaf	0.66 ± 0.51	1.58 ± 0.41	0.81 ± 0.52	10.39 ± 3.46	193.01 ± 155.94	199.97 ± 173.22	3.45 ± 2.25	0.30 ± 0.33	18.31 ± 13.80
Bark	1.08 ± 0.81	2.34 ± 0.48	0.97 ± 0.51	9.01 ± 0.74	128.25 ± 80.29	111.98 ± 110.87	4.31 ± 2.33	0.29 ± 0.29	8.14 ± 3.50
Pneumatophore	1.83 ± 0.76	3.17 ± 1.04	1.27 ± 0.49	16.67 ± 12.47	200.28 ± 120.73	322.58 ± 445.19	6.44 ± 3.62	2.86 ± 2.85	15.10 ± 3.86
<i>A. alba</i>									
Leaf	0.20 ± 0.18	1.93 ± 0.51	1.17 ± 0.30	12.10 ± 0.66	63.48 ± 2.19	63.87 ± 2.19	2.57 ± 1.20	0.68 ± 0.05	23.11 ± 12.95
Bark	1.06 ± 1.03	4.13 ± 1.37	0.90 ± 0.15	13.42 ± 7.02	71.21 ± 3.19	71.60 ± 3.19	2.51 ± 1.23	0.7 ± 0	26.71 ± 24.06
Pneumatophore	0.71 ± 0.45	2.54 ± 0.72	1.04 ± 0.09	19.91 ± 11.28	74.30 ± 31.81	74.69 ± 31.81	6.01 ± 2.43	1.75 ± 1.29	38.85 ± 26.28
Normal range in plants	0.1–2.4 ^a			4–15 ^{b,d}			0.05–10 ^d	0.1–10 ^c	8–100 ^a
Phytotoxic Concentrations in plants	5–10 ^{b,c}			15–20 ^{b,c}			>10 ^d	10–20 ^b	150–200 ^{b,c}

^aNagajyoti et al. (2010); ^bVameralli et al. (2010); ^cAlloway (2013); ^dKabata-Pendias (2010)

In general, leaf tissues have the next highest metal concentrations, followed by stems and root/pneumatophores (Weis et al. 2004). Accumulation of metals in leaf tissue may be related to sediment levels, but for some metals, the accumulation trend is not consistent with increasing sediment contamination. Restriction of upward movement is the unique strategy of metal tolerance in plants, since movement of metal ions into photosynthetic tissues can induce stress (Carbonell et al. 1998; Sneller et al. 1999), as well as promote the release of metals from the plant to the surrounding environment, through salt glands. The detailed ultrastructure of the salt glands present in three studied *Avicennia* species has been shown in Fig. 9.1.

In the present investigation, trace metals exhibited low accumulation pattern in leaf tissue, and elevated concentrations for Cd (1.14 mg kg^{-1} in *A. marina* at Phuldubi, Cu (21.40 mg kg^{-1} at Lot 8) and Mn ($1584.54 \text{ mg kg}^{-1}$ at Gangasagar) in *A. officinalis* were recorded. For bark tissue, Zn (57.43 mg kg^{-1}) and Co (5.10 mg kg^{-1}) showed maximum concentration in *A. alba* at Jharkhali which is mainly concerned to its unique phytoextraction capacity (Kathiresan et al. 2014, Chowdhury et al. 2015). Plant bark is widely noted for pinpointing airborne pollution and acts as passive accumulator because of its high lipid content and large surface area (Salamova and Hites 2012). After trace metal absorption through the root, it gets translocated into shoots, as harvest of root biomass is not considered feasible. Water molecules on the other hand, serve as a pump while evaporating from laminar surface and are responsible for translocation of metals (Tangahu et al. 2011). Therefore, excess metals move from roots to aerial parts and get distributed in different organs depending on the mobility of individual trace metals (Tam and Wong 1997). Trace metal uptake, translocation, and accumulation patterns varied among different plant organs, being significantly higher in pneumatophores than in bark and leaves. The key factor underlying low levels of trace metals in other organs could be their reduced transportation within the plants (Anjum et al. 2016).

The plant organs exhibited the following decreasing order of trace metal accumulation: pneumatophores > bark > leaves. Metal uptake from the soil might be affected by various plant characteristics and concerned mechanisms like transpirational activities, mycorrhization, root surface area, and production and excretion of root exudates (Vies et al. 1973) that affect solubility and accessibility of these metals in the soil (Stoltz and Greger 2002). However, different plant species show different uptake and translocation properties (Table 9.8). Some plants prefer roots as a major storage organ for metal accumulation and transport a little toward shoots, while others accrue more in shoots than roots (Yang et al. 2010, Deng et al. 2004). Generally, plants accumulate higher metal contents in roots than shoots (Sundaramoorthy et al. 2010) to control their aerial translocations among aboveground plant parts (Chatterjee and Chatterjee 2000; Tiwari et al. 2009) or due to immobilization or restriction of these metal ions within the root cortex to alleviate metal toxicity and their detrimental effects on the plants (Wang et al. 2007) or as an innate response of plants to metal toxicity to avert plant damage with reduced translocation to aerial parts of the plants (Mallick et al. 2010). Several reports have shown that fine roots of mangrove plants accumulate high trace metal concentrations; however, the extent of accumulation depends upon plant

Table 9.8 Detailed account of calculated translocation factor (TF)

	Cd	Co	Cr	Cu	Fe	Mn	Ni	Pb	Zn
<i>A. officinalis</i>									
S1	0.07	0.56	0.83	1.3	0.63	0.63	0.74	0.99	1.07
S2	12	1.23	0.69	0.69	0.75	0.75	0.59	0.4	2.34
S3	0.13	0.37	0.54	0.97	0.47	0.23	0.79	1.08	0.97
S4	0.37	0.57	0.73	0.7	2.43	2.42	47.5	0.35	1.51
S6	0.11	0.58	1.48	0.88	2.39	1.01	1.17	0.57	10.3
S7	0	0.78	0.66	1.69	1.5	2.68	0.53	0.04	11.3
S8	2.2	0.74	0.05	0.83	1.24	1.96	0.29	1.04	0.88
<i>A. marina</i>									
S3	0.47	0.61	1.26	0.69	1.55	1.55	0.38	1.07	0.37
S5	0.19	0.26	0.35	0.29	1.35	0.24	0.56	0.02	1.98
S6	0.57	0.7	0.75	1.81	0.26	0.81	0.47	0.12	0.82
S7	0.03	0.57	0.26	0.71	1.33	4.63	0.67	0.05	1.6
<i>A. alba</i>									
S1	0.07	0.52	0.87	0.98	0.67	0.67	0.4	0.27	1.59
S2	0.83	1.12	1.42	0.45	1.2	1.19	0.44	0.77	0.24

mechanisms and sediment chemistry (Chaudhuri et al. 2014). Aerial roots of mangrove plants diffuse oxygen into the substrate such that oxidation occurs in the rhizosphere, resulting in metal accumulation in fine roots (Chaudhuri et al. 2014; Machado et al. 2005; Marchand et al. 2011). The large surface area and high density of the root system may facilitate metal uptake, along with adsorption of metals subsequent to oxidation of metal sulfides (Lacerda et al. 1992, 1993; Marchand et al. 2011; Otero et al. 2006).

9.6.5 Quantification of Phytoextraction Efficiency

The efficiency of phytoextraction can be quantified by calculating the bioconcentration factor and translocation factor. Bioconcentration factor indicates the efficiency of a plant species in accumulating a metal into its tissues from the surrounding environment (Ladislas et al. 2012). It is calculated as follows (Zhuang et al. 2007):

$$\text{Bioconcentration Factor (BCF)} = C_{\text{tissue}}/C_{\text{soil}} \quad (9.1)$$

where C_{tissue} is the concentration of the target metal in the plant tissue and C_{soil} is the concentration of the same metal in the soil (substrate).

Translocation factor indicates the efficiency of the plant in translocating the accumulated metal from its roots to shoots. It is calculated as follows (Padmavathiamma and Li 2007):

$$\text{Translocation Factor} = C_{\text{shoot}}/C_{\text{root}} \quad (9.2)$$

where C_{shoot} is the concentration of the metal in plant shoots and C_{root} is the concentration of the metal in plant roots.

Both BCF and TF are important in screening hyperaccumulators for phytoextraction of heavy metals. The evaluation and selection of plants for phytoremediation purposes entirely depend on BCF and TF values (Wu et al. 2011). BCF is a more important measure than shoot metal concentration when considering the potential of a given candidate species for phytoextraction (Sakakibara et al. 2011). Translocation factor value greater than 1 indicates the translocation of the metal from root to aboveground part (Jamil et al. 2009). According to Yoon et al. (2006), only plant species with both BCF and TF greater than 1 have the potential to be used for phytoextraction. Hyperaccumulators have BCF greater than 1, sometimes reaching 50–100 (Cluis 2004). However, high metal concentrations in soil could result in a $\text{BCF} < 1$, for example, in ultramafic soils with 3000 mg kg^{-1} Ni in the soil and 2000 mg kg^{-1} in a plant, or conversely plants growing on soils deficient in essential trace elements (e.g., Zn) might be very efficient in sequestration and therefore have very high BCFs yet low absolute tissue metal concentrations. Thus BCF might have use for comparisons in case of growing plants in homogenized soil or in hydroponic cultures but has little advantage over simple comparisons of foliar metal concentrations (Van der Ent et al. 2013). BCF is also a convenient and reliable way for quantifying the relative difference in the bioavailability of heavy metals to plants (Naseem et al. 2009).

In comparison with other angiosperms, hyperaccumulator plants were capable to absorb trace metals within tissues beyond their normal physiological requirements (Baker and Brooks 1989). Plants which are tolerant to high metal concentration in tissues, along with some favorable additional traits, such as fast growth, easy propagation, and a profuse root system, are considered key factors for phytoextraction (Garbisu and Alkorta 2001; Vassilev et al. 2002). Determination of hyperaccumulator species was calculated using translocation factor, and bioaccumulation factor $\text{TF} > 1$ indicates preferential metal partitioning to plant shoot system (Baker and Whiting 2002; Branquinho et al. 2007; González and González-Chávez 2006; Yanqun et al. 2005). TF values of the present work reveal that *A. alba* exhibited high values for Zn (1.59 at Dabu) and Co, Cr, Fe, and Mn (1.12, 1.42, 1.2, and 1.19) at Jharkhali (Table 9.8). Another cosmopolitan member of Avicenniaceae, *A. officinalis*, exhibited high values for Cd (2.2 at Gangasagar, 12 at Jharkhali), Co (1.23 at Jharkhali), Cr (1.48 at Phuldubi), Cu (1.69 at Chemaguri, 1.3 at Dabu), Fe (1.24 at Gangasagar, 2.39 at Phuldubi, 1.5 at Chemaguri, and 2.43 at Gangadharpur), Mn (1.96 at Gangasagar, 1.01 at Phuldubi, 2.68 at Chemaguri, and 2.43 at Gangadharpur), Ni (1.17 at Phuldubi, 47.1 at Gangadharpur), Pb (1.04 at Gangasagar, 1.08 at Lot 8), and Zn (10.3 at Phuldubi, 11.3 at Chemaguri, 1.07 at Dabu, 2.34 at Jharkhali, and 1.51 at Gangadharpur). *Avicennia marina* showed high TF values for Cr (1.26 at Lot 8), Cu (1.81 at Phuldubi), Fe (1.55 at Lot 8, 1.35 at Chandanpiri, 1.33 at Chemaguri), Mn (4.63 at Chemaguri, 1.55 at Lot 8), Pb (1.07 at Lot 8), and Zn (1.98 at Chandanpiri, 1.6 at Chemaguri).

Bioconcentration factor, which is also considered as a tool for hyperaccumulation indicator, exhibited high values of Cd (range: 1.1 in leaf at Gangasagar to 116 in pneumatophore at Gangadharpur) and Mn (range: 1.25 in pneumatophore to 2.44 in leaf, both at Gangasagar) for *A. officinalis*. High values of Cd (range: 2.09 in leaf at Lot 8 to 27.5 in pneumatophore at Chandanpiri) were recorded in *Avicennia marina*, whereas *A. alba* recorded significant values of Cd (2.47 in leaf to 13.8 in pneumatophore at Jharkhali) and Zn (1.18 in bark at Dabu to 1.27 in pneumatophore at Jharkhali). Thus, *A. officinalis* and *A. marina* could be considered as better metal accumulators than *A. alba*. They might be potential plants suitable for phytoextraction of metal-contaminated soils. Nevertheless, they could be potential tools for phytoextraction as they are adapted to the local climatic conditions and have high aboveground biomass and high propagation rates (Phaenark et al. 2009).

9.6.6 Statistical Analyses

In order to establish relationship among metals and determine their common sources in the Sundarban region, a correlation matrix was calculated. According to the values of Pearson correlation coefficients, significant positive correlation existed among the majority of the metals studied ($p < 0.05\%$). For all the plants at individual stations, significant positive correlation was shown by Co with Cr (*A. officinalis*, $r = 0.90$; *A. marina*, $r = 0.92$; *A. alba*, $r = 0.87$), Cu with Cr (*A. officinalis*, $r = 0.76$; *A. marina*, $r = 0.90$; *A. alba*, $r = 0.85$), Co with Fe (*A. officinalis*, $r = 0.67$; *A. marina*, $r = 0.81$; *A. alba*, $r = 0.88$), Cr with Fe (*A. officinalis*, $r = 0.87$; *A. marina*, $r = 0.95$; *A. alba*, $r = 0.99$), Cu with Fe (*A. officinalis*, $r = 0.62$; *A. marina*, $r = 0.82$; *A. alba*, $r = 0.89$), Co with Ni (*A. officinalis*, $r = 0.76$; *A. marina*, $r = 0.85$; *A. alba*, $r = 0.86$), Cr with Ni (*A. officinalis*, $r = 0.93$; *A. marina*, $r = 0.95$; *A. alba*, $r = 0.99$), Cu with Ni (*A. officinalis*, $r = 0.63$; *A. marina*, $r = 0.87$; *A. alba*, $r = 0.87$), Fe with Ni (*A. officinalis*, $r = 0.96$; *A. marina*, $r = 0.99$; *A. alba*, $r = 0.98$), Co with Pb (*A. officinalis*, $r = 0.76$; *A. marina*, $r = 0.88$; *A. alba*, $r = 0.86$), Cr with Pb (*A. officinalis*, $r = 0.76$; *A. marina*, $r = 0.96$; *A. alba*, $r = 0.99$), Cu with Pb (*A. officinalis*, $r = 0.92$; *A. marina*, $r = 0.92$; *A. alba*, $r = 0.80$), Fe with Pb (*A. officinalis*, $r = 0.67$; *A. marina*, $r = 0.97$; *A. alba*, $r = 0.97$), Ni with Pb (*A. officinalis*, $r = 0.67$; *A. marina*, $r = 0.98$; *A. alba*, $r = 0.99$), Cu with Co (*A. officinalis*, $r = 0.81$; *A. marina*, $r = 0.93$), Zn with Co (*A. officinalis*, $r = 0.70$; *A. marina*, $r = 0.75$), Zn with Cr (*A. officinalis*, $r = 0.74$; *A. marina*, $r = 0.83$), Cu with Zn (*A. officinalis*, $r = 0.92$; *A. marina*, $r = 0.77$), Fe with Zn (*A. officinalis*, $r = 0.66$; *A. marina*, $r = 0.83$), and Mn with Co (*A. marina*, $r = 0.74$; *A. alba*, $r = 0.88$), with Cr (*A. marina*, $r = 0.78$; *A. alba*, $r = 0.99$), with Cu (*A. marina*, $r = 0.89$; *A. alba*, $r = 0.86$), with Fe (*A. marina*, $r = 0.79$; *A. alba*, $r = 0.10$), with Ni (*A. marina*, $r = 0.84$; *A. alba*, $r = 0.99$), and with Pb (*A. marina*, $r = 0.88$; *A. alba*, $r = 0.99$) at all stations. This indicates that that these metals tend to accumulate together and derived from similar sources and also moving together (Soliman et al. 2015). One way analysis of variance (ANOVA) showed significant

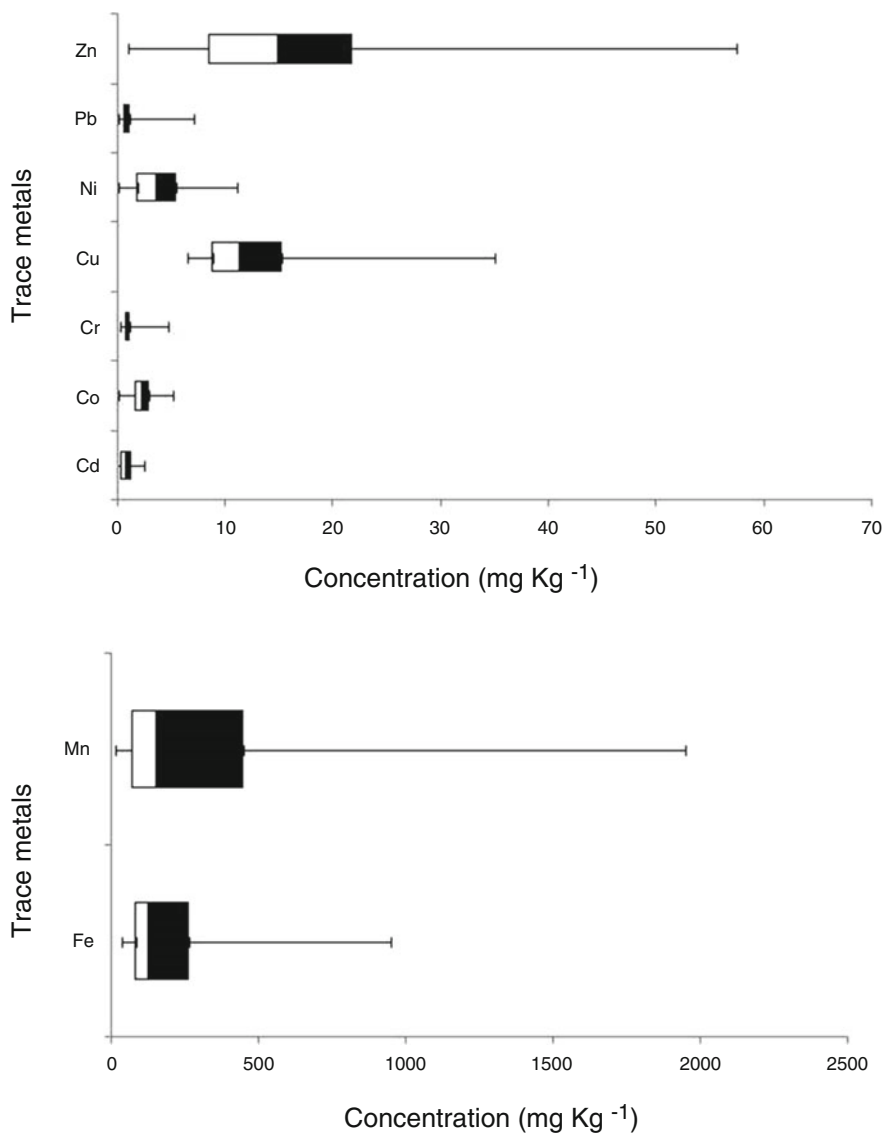

Fig. 9.2 Box-and-whisker plots of trace metal concentration in the mangroves. The central bar in the *box* displays the median value; the ends of the *whiskers* represent the minimum and maximum values. The start and end of the *boxes* include half the data points between the median and extremes of the range

variation ($F = 21.78$, $P < 0.01$) between metal and plant species ($F = 3.49$, $P < 0.05$). The results of discriminant analysis, when used in conjunction with the box-and-whisker plots (Fig. 9.2), provided statistical evidence that the trace metals were not homogeneously distributed in all mangrove plant organs.

Table 9.9 Matrix of the principal component analysis showing the loadings and the scores of the first five principal components

Variable	PC1	PC2	PC3	PC4	PC5
Cd	-0.473	0.498	-0.520	0.009	0.189
Co	-0.587	0.484	-0.216	-0.234	-0.171
Cr	-0.489	-0.138	0.052	0.608	-0.590
Cu	-0.802	-0.384	-0.026	-0.151	0.037
Fe	-0.407	0.264	0.660	-0.153	-0.130
Mn	-0.475	0.169	0.642	-0.223	0.177
Ni	-0.293	-0.280	-0.552	-0.442	-0.211
Pb	-0.585	-0.250	-0.102	0.488	0.514
Zn	-0.124	-0.830	0.123	-0.254	0.006
Eigenvalue	2.2843	1.5755	1.4984	1.0183	0.7708
Total variance %	0.254	0.175	0.166	0.113	0.086
Cumulative variance %	0.254	0.429	0.595	0.709	0.794

Principal component analysis (PCA) is used to determine the degree of pollution by trace metals from lithogenic and anthropogenic sources (Sun et al. 2010; Chen et al. 2005; Rodríguez et al. 2008; Facchinelli et al. 2001). It enables a reduction in data and description of a given multidimensional system by means of a small number of new variables. Liu et al. (2003) classified the factor loading as strong, moderate, and weak depending on the loading values >0.75 , $0.75-0.50$, and $0.50-0.30$, respectively. According to Morrison (1967), principal components should account for approx. 75% of the total variance. Relevant components are those whose eigenvalue is higher than 1 (Kaiser 1960). The screen plot of the characteristic roots (eigenvalues) of PCA was applied to identify the numbers of PCs to be retained to understand the underlying data structure. This led to the formation of five principal components (Table 9.9). The first component accounted for 25.4%, the second for 17.5%, the third for 16.6%, the fourth for 11.3%, and the fifth for 8.6% of the total variation of the data. The first five components account for 53% of variances for all of the data. The first component represents the maximum variation of the data set. The components were rotated using varimax rotation. There are various rotational strategies that have been proposed. Probably the best known approach is called varimax rotation. The principal components are rotated so that the total sum of squares of the loadings along each new axis is maximized (Brereton 1990). The goal of all of these strategies is to obtain a clear pattern of loadings, that is, factors that are somehow clearly marked by high loadings for some variables and low loadings for others. This general pattern is also sometimes referred to as a simple structure (a more formalized definition can be found in most standard textbooks). The higher loading of a variable implies a larger contribution to the variation, accounting for the varimax-rotated principal components. Table 9.5 gives the rotated loadings and communality for each element. The loadings were negatively strong for Cu and negatively moderate for Co and Pb on the first component, negatively strong for Zn on the second component, negatively

moderate for Cd and Ni and positively moderate for Fe and Mn on the third component, positively moderate for Cr on the fourth component, and negatively moderate for Cr on the fifth component. Fifth component also showed positively moderate loading for Pb.

The hierarchical method of cluster analysis (CA) is used in this study to organize information about variables so that clusters can be formed. As a distance measure, the standardized Euclidean distance was considered, which is one of the most commonly adopted measures (Reghunath et al. 2002). The distance cluster represents the degree of association between elements. The lower the value on the distance cluster, the more significant was the association (Lee et al. 2006). In the investigation, CA was carried out for trace metal concentration in sediment of the eight study sites to understand the relationship among them. From the results, two distinct clusters are recognized (Fig. 9.3a): (1) cluster of Dabu and Chandanpiri and (2) cluster of Phuldubi and Chemaguri. The association may reflect the inputs from some anthropogenic activities at Dabu and Chandanpiri as both sites are associated with intensive fishing and local uses of antifouling paints to resist the biofouling. On the other hand, both the sampling sites Phuldubi and Chemaguri are situated at Sagar Island and encounter with the trace metals that may originate from the natural parent materials of the soils. From Fig. 9.3b, two distinct clusters are evident: cluster 1 of Cr–Ni with Pb in outliers and (2) cluster of Cu–Zn. Trace metals of cluster 1 are all nonessential and toxic in nature, and in the natural environment they are found in less quantity. Possibly they originated from similar natural or anthropogenic sources. Cluster 2 suggests that the association between these elements was very significant, and in sediment they move together.

Three clusters of highly similar group were seen in each plant species as revealed in Fig. 9.4a, b, c. (1) Clustering of Cd–Cr with Pb in outliers was seen which indicated that these toxic trace metals moved together in the plant body, (2) association of Cu–Zn indicated their requirement in plant for their metabolic activity for which they share the same mechanism, and (3) Fe–Mn remained isolated and reflected their high bioavailability in sediment for which they were found in the highest concentration in all the plant species. (Fig. 9.4a, b, c).

9.6.7 Assessment of Sediment Trace Metal Pollution

The I_{geo} value was negatively related with eight metals (Al, Co, Cr, Fe, Mg, Mn, Ni, and Zn) at all stations, with values lower than 1.0 for Cu and Pb indicating unpolluted to moderately polluted status. The EF values for Co (1.83–2.26), Cu (2.16–7.72), Mg (1.5–2.23), Mn (2.31–2.85), Pb (3.52–7.63), and Zn (2.21–3.18) were very high, suggesting some point pollution sources for them. Intensive fishing and ferry services, sewage drainage from the mainland, and other commercial activities are supposed to be potential sources for the enrichment of these metals in study sites.

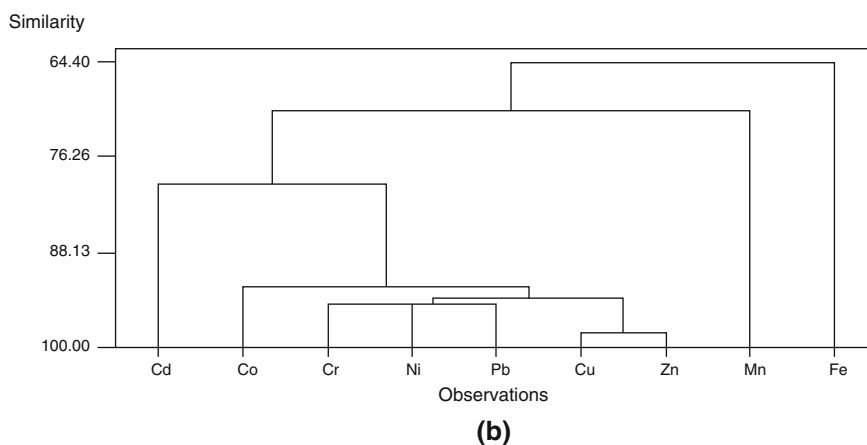
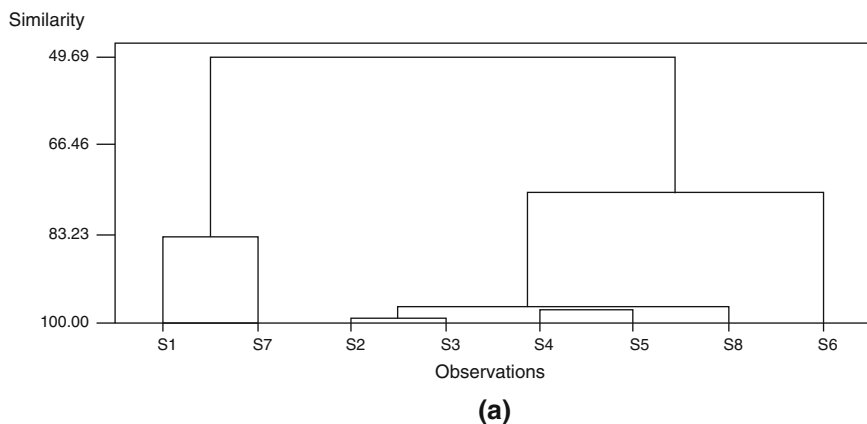

Fig. 9.3 Results of dendrogram showing clustering of trace metals (a) in all study sites, (b) in sediment

9.6.8 Sediment Quality Guidelines (SQGs)

Effect range-low (ERL) and threshold effect level (TEL) values were exceeded by Cu, whereas Pb exceeded only TEL value at Gangadharpur, implying that adverse consequences to biota may occasionally occur. Other trace metals did not exceed both effect range-median (ERM) and probable effect level (PEL) values, and hence no adverse effects are expected. Coal combustion from thermal power plants located at the upstream of Hooghly River (as shown in Fig. 6.1), vehicle emission, and precipitation of aerosols are the important sources of Pb as endorsed by Suresh et al. 2015. Major sources of Cu in Sundarban regions originated from the use of antifouling paints in boats (Usman et al. 2013) and extensive use of fertilizers and pesticides for agricultural needs. However, apart from human-induced stresses, the

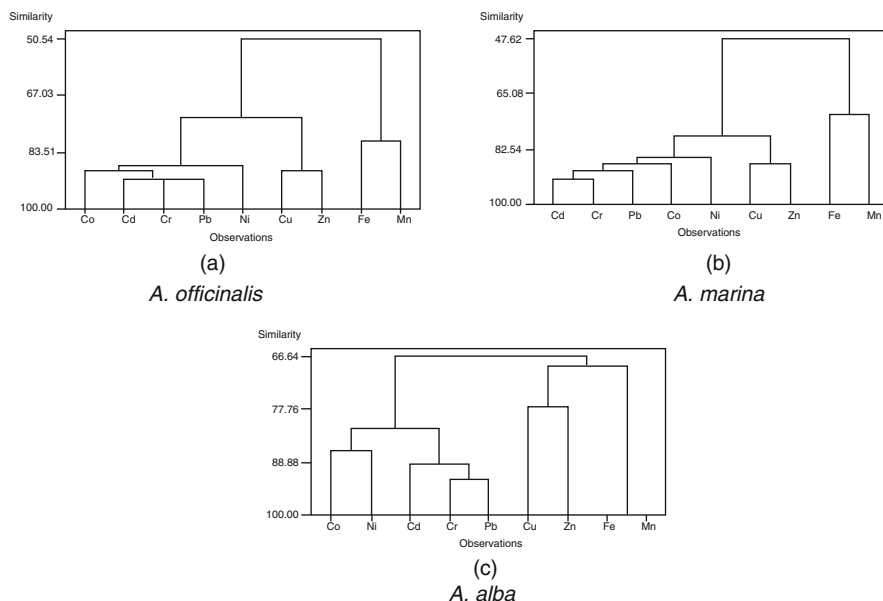

Fig 9.4 Results of dendrogram showing clustering of trace metals in (a) *A. officinalis*, (b) *A. marina*, and (c) *A. alba*

local geological background and depositional settings might also be concerned for SQG exceedance.

9.7 Conclusion

The work demonstrates the strong metal retention capacity of three native facultative mangrove species of *Avicennia*, adopting the phytostabilization and phytoextraction strategies. These plants can act as physical and biogeochemical barrier for trace metals originated from domestic wastewater, agricultural runoff, and industrial effluents and can help in accumulation and partitioning of trace metals in aerial and subaerial organs. These plants could be extensively used for estuarine management to protect the stressed Sundarban coastal marine habitats from pollution and also as a barrier against catastrophic events (e.g., cyclones, storms, etc.). Hence if these mangrove plants are removed from Sundarban coastal regions, trace metals become more readily available to enter the food chain, and this seems to be dangerous as the coastal people get most of their food resources (e.g., finfishes and shellfishes) from this region. Sundarban is performing as an effective phytostabilizer that limits the bioavailability and spread of trace metals and directly helpful for environmental restoration and management. However, in future course of studies, speciation and readily available fractions of trace metals in individual

mangrove organs are to be considered for getting the sound feature of pollution. Recently, biochar has been reported to positively impact a multiple set of soil processes, such as soil biology, controlling soil-borne pathogens, enhancing nitrogen fixation, improving soil physical and chemical properties, and other processes (Lone et al. 2015). However, very little biochar is still experimentally utilized as soil amendment mainly because these benefits are yet to be quantified, and the concerned mechanisms are poorly explored till data by which the soil health and fertility are improved.

References

- Abraham GMS, Parker RJ (2008) Assessment of heavy metal enrichment factors and the degree of contamination in marine sediments from Tamaki estuary, Auckland, New Zealand. *Environ Monit Assess* 136(1–3):227–238
- Agnello AC, Huguenot D, Van Hullebusch ED, Esposito G (2016) Citric acid-and tween® 80-assisted phytoremediation of a co-contaminated soil: alfalfa (*Medicago sativa* L.) performance and remediation potential. *Environ Sci Pollut Res* 23(9):9215–9226
- Ali H, Khan E, Sajad MA (2013) Phytoremediation of heavy metals—concepts and applications. *Chemosphere* 91(7):869–881
- Alloway BJ (2013) Heavy metals and metalloids as micronutrients for plants and animals. In: *Heavy metals in soils*. Springer, Dordrecht, pp 195–209
- Angino EE, Magnuson LM, Waugh TC, Galle OK, Bredfeldt J (1970) Arsenic in detergents: possible danger and pollution hazard. *Science* 168(3929):389–390
- Anjum NA, Duarte B, Caçador I, Sleimi N, Duarte AC, Pereira E (2016) Biophysical and biochemical markers of metal/metalloid-impacts in salt marsh halophytes and their implications. *Front Environ Science* 4:24
- Arora A, Sairam RK, Srivastava GC (2002) Oxidative stress and antioxidative system in plants. *Curr Sci* 82(10):1227–1238
- Baker AJM, Brooks R (1989) Terrestrial higher plants which hyperaccumulate metallic elements. A review of their distribution, ecology and phytochemistry. *Biorecovery* 1(2):81–126
- Baker AJM, McGrath SP, Reeves RD, Smith JAC (2000) Metal hyper accumulator seedlings: a review of the ecology and physiology of a biological resource for phytoremediation of metal-polluted soils. In: *Phytoremediation of contaminated soil and water*. Lewis Publishers
- Baker AJ, Whiting SN (2002) In search of the holy grail—a further step in understanding metal hyperaccumulation? *New Phytol* 155(1):1–4
- Balakrishnan B, Sahu BK, Ranishree JK, Lourduraj AV, Nithyanandam M, Packiriswamy N, Panchatcharam P (2017) Assessment of heavy metal concentrations and associated resistant bacterial communities in bulk and rhizosphere soil of *Avicennia marina* of Pichavaram mangrove, India. *Earth Sci* <http://dx.doi.org/10.1007/s12665-016-6378-7>
- Bandaranayake WM (1998) Traditional and medicinal uses of mangroves. *Mangrove Salt Marshes* 2(3):133–148
- Barceló J, Poschenrieder C (2003) Phytoremediation: principles and perspectives. *Contrib Sci* 2(3):333–344
- Batty LC, Baker AJ, Wheeler BD (2002) Aluminum and phosphate uptake by *Phragmites australis*: the role of Fe, Mn and Al root plaques. *Ann Bot* 89(4):443–449
- Bhattacharya BD, Bhattacharya AK, Rakshit D, Sarkar SK (2014) Impact of the tropical cyclonic storm ‘Aila’ on the water quality characteristics and mesozooplankton community structure of Sundarban mangrove wetland, India. *Indian J Geo-Mar* 43(2):216–223

- Bhattacharya BD, Nayak DC, Sarkar SK, Biswas SN, Rakshit D, Ahmed MK (2015) Distribution of dissolved trace metals in coastal regions of Indian Sundarban mangrove wetland: a multivariate approach. *J Clean Prod* 96:233–243
- Branquinho C, Serrano HC, Pinto MJ, Martins-Loução MA (2007) Revisiting the plant hyperaccumulation criteria to rare plants and earth abundant elements. *Environ Pollut* 146(2):437–443
- Brennan MA, Shelley ML (1999) A model of the uptake, translocation, and accumulation of lead (Pb) by maize for the purpose of phytoextraction. *Ecol Eng* 12(3):271–297
- Breerton RG (1990) *Chemometrics: applications of mathematics and statistics to laboratory systems*. Ellis Horwood, New York
- Cai Y, Ma LQ (2003) Metal tolerance, accumulation, and detoxification in plants with emphasis on arsenic in terrestrial plants
- Carbonell AA, Aarabi MA, DeLaune RD, Gambrell RP, Patrick Jr WH (1998) Bioavailability and uptake of arsenic by wetland vegetation: effects on plant growth and nutrition. *J Environ Sci Health A* 33(1):45–66
- Chai M, Li R, Zang Q (2017) Effects of mangrove plants on heavy metal risk in sediment based on SEM–AVS analysis. *Reg Stud Mar Sci* 13(2017):12–18
- Chakraborty D, Bhar S, Majumdar J, Santra SC (2013) Heavy metal pollution and phytoremediation potential of *Avicennia officinalis* L. in the southern coast of the Hoogly estuarine system. *Int J Environ Sci* 3(6):2291–2303
- Chatterjee J, Chatterjee C (2000) Phytotoxicity of cobalt, chromium and copper in cauliflower. *Environ Pollut* 109(1):69–74
- Chatterjee MVSFE, Silva Filho EV, Sarkar SK, Sella SM, Bhattacharya A, Satpathy KK, Prasad MVR, Chakraborty S, Bhattacharya BD (2007) Distribution and possible source of trace elements in the sediment cores of a tropical macrotidal estuary and their ecotoxicological significance. *Environ Int* 33(3):346–356
- Chaturvedi N, Dhal NK, Patra HK (2015) An assessment of heavy metal remediation potential of *Lawsonia inermis* L. from iron ore tailings. *Res Plant Biol* 5(1)
- Chaudhuri P, Nath B, Birch G (2014) Accumulation of trace metals in grey mangrove *Avicennia marina* fine nutritive roots: the role of rhizosphere processes. *Mar Pollut Bull* 79(1):284–292
- Chen TB, Zheng YM, Lei M, Huang ZC, Wu HT, Chen H et al (2005) Assessment of heavy metal pollution in surface soils of urban parks in Beijing, China. *Chemosphere* 60(4):542–551
- Chowdhury R, Favas PJ, Pratas J, Jonathan MP, Ganesh PS, Sarkar SK (2015) Accumulation of trace metals by mangrove plants in Indian Sundarban wetland: prospects for phytoremediation. *Int J Phytoremediation* 17(9):885–894
- Chowdhury R, Favas PJC, Jonathan MP, Ahmed K, Sarkar SK (2017) Trace metal uptake by mangrove plants and their possible phytoremediation applications in Indian Sundarban wetland. *Mar Pollut Bull*
- Chowdhury, R., Lyubun, Y., Favas, P. J., & Sarkar, S. K. (2016). Phytoremediation potential of selected mangrove plants for trace metal contamination in Indian Sundarban wetland. In: *Phytoremediation*. Springer International Publishing, pp 283–310
- Cluis C (2004) Junk-greedy greens: phytoremediation as a new option for soil decontamination. *BioTeach J* 2(6):1–67
- Cunningham SD, Ow DW (1996) Promises and prospects of phytoremediation. *Plant Physiol* 110(3):715
- Cunningham SD, Anderson TA, Schwab AP, Hsu FC (1996) Phytoremediation of soils contaminated with organic pollutants. *Adv Agron* 56(1):55–114
- De Dorlodot S, Lutts S, Bertin P (2005) Effects of ferrous iron toxicity on the growth and mineral composition of an interspecific rice. *J Plant Nutr* 28(1):1–20
- Deng H, Ye ZH, Wong MH (2004) Accumulation of lead, zinc, copper and cadmium by 12 wetland plant species thriving in metal-contaminated sites in China. *Environ Pollut* 132(1):29–40
- Dushenkov S (2003) Trends in phytoremediation of radionuclides. *Plant Soil* 249(1):167–175

- EPA (2000) A Citizen's guide to phytoremediation. EPA 542-F-98-011. United States Environmental Protection Agency, p 6
- Ernst WH (2005) Phytoextraction of mine wastes—options and impossibilities. *Chem Erde-Geochem* 65:29–42
- Facchinelli A, Sacchi E, Mallen L (2001) Multivariate statistical and GIS-based approach to identify heavy metal sources in soils. *Environ Pollut* 114(3):313–324
- Folk RL, Ward WC (1957) Brazos River bar: a study in the significance of grain size parameters. *J Sediment Res* 27(1):3–26
- Freitas H, Prasad MNV, Pratas J (2004) Plant community tolerant to trace elements growing on the degraded soils of Sao Domingos mine in the south east of Portugal: environmental implications. *Environ Int* 30(1):65–72
- Friedman GM, Sanders JE (1978) Principles of sedimentology. Wiley, New York
- Gao X, Chen CTA (2014) Heavy metal pollution status in surface sediments of the coastal Bohai Bay. *Water Res* 46(6):1901–1911
- Garbisu C, Alkorta I (2001) Phytoextraction: a cost-effective plant-based technology for the removal of metals from the environment. *Bioresour Technol* 77(3):229–236
- Golestaninasab M, Malek M, Roohi A, Karbassi AR, Amoozadeh E, Rashidinejad R, Ghayoumi R (2014) A survey on bioconcentration capacities of some marine parasitic and free-living organisms in the Gulf of Oman. *Ecol Indic* 37:99–104
- González RC, González-Chávez MCA (2006) Metal accumulation in wild plants surrounding mining wastes. *Environ Pollut* 144(1):84–92
- Gupta S, Chakrabarti SK (2013) Effect of heavy metals on different anatomical structures of *Bruguiera sexangula*. *Int J bio-res stress. Manage* 4(4):605–609
- Harbison PAT (1986) Mangrove muds—a sink and a source for trace metals. *Mar Pollut Bull* 17(6):246–250
- Hinchman RR, Negri MC, Gatliff EG (1995) Phytoremediation: using green plants to clean up contaminated soil, groundwater, and wastewater. Argonne National Laboratory Hinchman, Applied Natural Sciences
- Jadia CD, Fulekar MH (2009) Phytoremediation of heavy metals: recent techniques. *Afr J Biotechnol* 8(6)
- Jamil S, Abhilash PC, Singh N, Sharma PN (2009) *Jatropha curcas*: a potential crop for phytoremediation of coal fly ash. *J Hazard Mater* 172(1):269–275
- Jaques AP (1987) Summary of emissions of antimony, arsenic, cadmium, chromium, copper, lead, manganese, mercury and nickel in Canada. Industrial Programs Branch, Environment Canada, Ottawa, Ontario, Canada. Draft Internal Document, 7
- Jonathan MP, Sarkar SK, Roy PD, Alam MA, Chatterjee M, Bhattacharya BD et al (2010) Acid leachable trace metals in sediment cores from Sunderban mangrove wetland, India: an approach towards regular monitoring. *Ecotoxicology* 19(2):405–418
- Joshi N (2007) Biosorption of heavy metals. Department of Biotechnology and Environmental Sciences Thapar Institute of Engineering and Technology Patiala –147004.1-25. Doctoral dissertation
- Kabata-Pendias A (2010) Trace elements in soils and plants, 3rd edn. CRC Press, Boca Raton
- Kaiser HF (1960) The application of electronic computers to factor analysis. *Educ Psychol Meas* 20:141–151
- Kamath R, Rentz JA, Schnoor JL, Alvarez PJJ (2004) Phytoremediation of hydrocarbon-contaminated soils: principles and applications. *Stud Surf Sci Catal* 151:447–478
- Karami A, Shamsuddin ZH (2010) Phytoremediation of heavy metals with several efficiency enhancer methods. *Afr J Biotechnol* 9(25):3689–3698
- Kathiresan K, Saravanakumar K, Sahu SK, Sivasankaran M (2014) Adenosine deaminase production by an endophytic bacterium (*Lysinibacillus* sp.) from *Avicennia marina*. *Biotech* 4(3):235–239
- Khan MA, Ahmad I, Rahman IU (2007) Effect of environmental pollution on heavy metals content of *Withania somnifera*. *J Chin Chem Soc* 54(2):339–343

- Krumbein WC, Pettijohn FJ (1938) Manual of sedimentary petrography: sampling, preparation for analysis, mechanical analysis and statistical analysis; shape analysis, mineralogical analysis, chemical analysis and mass properties (No. QE471 K78)
- Küpper H, Zhao FJ, McGrath SP (1999) Cellular compartmentation of zinc in leaves of the hyperaccumulator *Thlaspi caerulescens*. *Plant Physiol* 119(1):305–312
- Lacerda LD, Souza CMM, Pestana MHD (1988) Geochemical distribution of Cd, Cu, Cr and Pb in sediments of estuarine areas along the southeastern Brazilian coast. In: *Metals in coastal environments of Latin America*. Springer, Berlin/Heidelberg, pp 86–99
- Lacerda LD, Fernandez MA, Calazans CF, Tanizaki KF (1992) Bioavailability of heavy metals in sediments of two coastal lagoons in Rio de Janeiro, Brazil. *Hydrobiologia* 228(1):65–70
- Lacerda LDD, Carvalho CEV, Tanizaki KF, Ovale ARC, Rezende CE (1993) The biogeochemistry and trace metals distribution of mangrove rhizospheres. *Biotropica* 25(3):252–257
- Ladislav S, El-Muffeh A, G erente C, Chazarenc F, Andr es Y, B echet B (2012) Potential of aquatic macrophytes as bioindicators of heavy metal pollution in urban stormwater runoff. *Water Air Soil Pollut* 223(2):877–888
- Laghlimi M, Baghdad B, El Hadi H, Bouabdli A (2015) Phytoremediation mechanisms of heavy metal contaminated soils: a review. *Open J Ecol* 5(08):375
- Lasat MM (2002) Phytoextraction of toxic metals: a review of biological mechanism. *J Environ Qual* 31(1):109–120
- Lee CSL, Li X, Shi W, Cheung SCN, Thornton I (2006) Metal contamination in urban, suburban, and country park soils of Hong Kong: a study based on GIS and multivariate statistics. *Sci Total Environ* 356(1):45–61
- Lewis S, Donkin ME, Depledge MH (2001) Hsp70 expression in *Enteromorpha intestinalis* (Chlorophyta) exposed to environmental stressors. *Aquat Toxicol* 51(3):277–291
- Li H, Wang Y, Zhu W, Xu Q, He Y, Tang W, Zhuo H, Wang D, Wu J, Li D (2013) Seismic characteristics and processes of the Plio-quaternary unidirectionally migrating channels and contourites in the northern slope of the South China Sea. *Mar Pet Geol* 43:370–380
- Liu CW, Lin KH, Kuo YM (2003) Application of factor analysis in the assessment of groundwater quality in a blackfoot disease area in Taiwan. *Sci Total Environ* 313(1):77–89
- Liu W, Zhou Q, An J, Sun Y, Liu R (2010) Variations in cadmium accumulation among Chinese cabbage cultivars and screening for Cd-safe cultivars. *J Hazard Mater* 173(1):737–743
- Lone AH, Najjar GR, Ganie MA, Sofi JA, Ali T (2015) Biochar for sustainable soil health: a review of prospects and concerns. *Pedosphere* 25(5):639–653
- Long ER (2006) Calculation and uses of mean sediment quality guideline quotients: a critical review. *Environ Sci Technol* 40(6):1726–1736
- Long ER, Macdonald DD, Smith SL, Calder FD (1995) Incidence of adverse biological effects within ranges of chemical concentrations in marine and estuarine sediments. *Environ Manag* 19(1):81–97
- Long X, Yang XE, Ni W (2002) Current situation and prospect on the remediation of soils contaminated by heavy metals. *J Appl Ecol* 13(6):757
- Loska K, Wiechula D, Korus I (2004) Metal contamination of farming soils affected by industry. *Environ Int* 30(2):159–165
- MacDonald DD, Ingersoll CG, Berger TA (2000) Development and evaluation of consensus-based sediment quality guidelines for freshwater ecosystems. *Arch Environ Contam Toxicol* 39(1):20–31
- Macek T, Mackova M, K as J (2000) Exploitation of plants for the removal of organics in environmental remediation. *Biotechnol Adv* 18(1):23–34
- MacFarlane GR, Burchett MD (2000) Cellular distribution of copper, lead and zinc in the grey mangrove, *Avicennia marina* (Forsk.) Vierh. *Aquat Bot* 68(1):45–59
- MacFarlane GR, Pulkownik A, Burchett MD (2003) Accumulation and distribution of heavy metals in the grey mangrove, *Avicennia marina* (Forsk.) Vierh.: biological indication potential. *Environ Pollut* 123(1):139–151

- Machado W, Gueiros BB, Lisboa-Filho SD, Lacerda LD (2005) Trace metals in mangrove seedlings: role of iron plaque formation. *Wetl Ecol Manag* 13(2):199–206
- Macnair MR, Bert V, Huitson SB, Saumitou-Laprade P, Petit D (1999) Zinc tolerance and hyperaccumulation are genetically independent characters. *Proc R Soc Lond B Biol Sci* 266 (1434):2175–2179
- Mallick S, Sinam G, Mishra RK, Sinha S (2010) Interactive effects of Cr and Fe treatments on plants growth, nutrition and oxidative status in *Zea mays* L. *Ecotoxicol Environ Saf* 73 (5):987–995
- Mandal RN, Naskar KR (2008) Diversity and classification of Indian mangroves: a review. *Trop Ecol* 49(2):131–146
- Marchand C, Allenbach M, Lallier-Verges E (2011) Relationships between heavy metals distribution and organic matter cycling in mangrove sediments (Conception Bay, New Caledonia). *Geoderma* 160(3):444–456
- Marchand C, Baltzer F, Lallier-Vergès E, Albéric P (2004) Pore-water chemistry in mangrove sediments: relationship with species composition and developmental stages (French Guiana). *Mar Geol* 208(2):361–381
- Mattina MI, Lannucci-Berger W, Musante C, White JC (2003) Concurrent plant uptake of heavy metals and persistent organic pollutants from soil. *Environ Pollut* 124(3):375–378
- Moore JW (2012) Inorganic contaminants of surface water: research and monitoring priorities. Springer Science & Business Media
- Morelli G, Gasparon M (2014) Metal contamination of estuarine intertidal sediments of Moreton Bay, Australia. *Mar Pollut Bull* 89:435–443
- Morrison D (1967) Multivariate statistical methods. McGraw-Hill, New York
- Mougin C (2002) Bioremediation and phytoremediation of industrial PAH-polluted soils. *Polycycl Aromat Compd* 22(5):1011–1043
- Müller G (1979) Heavy metals in sediment of the Rhine-changes since 1971. *Umschau in Wissenschaft und Technik* 79(24):778–783
- Müller G (1981) Schwermetallbelastung der sedimente des neckars und seiner nebenflüsse: eine estandsaufnahme 105:157–164
- Nagajyoti PC, Lee KD, Sreekanth TVM (2010) Heavy metals, occurrence and toxicity for plants: a review. *Environ Chem Lett* 8(3):199–216
- Namazi R, Zabihollahi R, Behbahani M, Rezaei A (2013) Inhibitory activity of *Avicennia marina*, a medicinal plant in Persian folk medicine, against HIV and HSV. *Iran J Pharm Res* 12(2):435
- Naseem S, Bashir E, Shireen K, Shafiq S (2009) Soil-plant relationship of *Pteropyrum olivieri*, a serpentine flora of Wadh, Balochistan, Pakistan and its use in mineral prospecting. *Studia UBB Geologia* 54(2):33–39
- Naskar KR (2004) Manual of Indian mangroves. Daya Publishing House, New Delhi
- Otero XL, Ferreira TO, Vidal-Torrado P, Macías F (2006) Spatial variation in pore water geochemistry in a mangrove system (Pai Matos Island, Cananea-Brazil). *Appl Geochem* 21 (12):2171–2186
- Padmavathiamma PK, Li LY (2007) Phytoremediation technology: hyper-accumulation metals in plants. *Water Air Soil Pollut* 184(1–4):105–126
- Paquin D, Ogoshi R, Campbell S, Li QX (2002) Bench-scale phytoremediation of polycyclic aromatic hydrocarbon-contaminated marine sediment with tropical plants. *Int J Phytoremediation* 4(4):297–313
- Peng K, Li X, Luo C, Shen Z (2006) Vegetation composition and heavy metal uptake by wild plants at three contaminated sites in Xiangxi area, China. *J Environ Sci Health A* 41(1):65–76
- Phaenark C, Pokethitiyook P, Kruatrachue M, Ngernsarsaruy C (2009) Cd and Zn accumulation in plants from the Padaeng zinc mine area. *Int J Phytoremediation* 11(5):479–495
- Pi N, Tam NFY, Wong MH (2011) Formation of iron plaque on mangrove roots receiving wastewater and its role in immobilization of wastewater-borne pollutant. *Mar Pollut Bull* 63:402–411

- Prasad MNV (2003) Phytoremediation of metal-polluted ecosystems: hype for commercialization. *Russ J Plant Physiol* 50(5):686–701
- Pulford ID, Watson C (2003) Phytoremediation of heavy metal-contaminated land by trees—a review. *Environ Int* 29(4):529–540
- Quattrocchi U (2012) CRC world dictionary of medicinal and poisonous plants: common names, scientific names, eponyms, synonyms, and etymology (5 volume set), vol 5. CRC Press, p. 897
- Raskin I, Ensley BD (2000) Recent developments for in situ treatment of metal contaminated soils. In: *Phytoremediation of toxic metals: using plants to clean up the environment*. Wiley, New York
- Reeves RD (2003) Tropical hyperaccumulators of metals and their potential for phytoextraction. *Plant Soil* 249(1):57–65
- Reghunath R, Murthy TS, Raghavan BR (2002) The utility of multivariate statistical techniques in hydrogeochemical studies: an example from Karnataka, India. *Water Res* 36(10):2437–2442
- Robinson B, Fernández JE, Madejón P, Marañón T, Murillo JM, Green S, Clothier B (2003) Phytoextraction: an assessment of biogeochemical and economic viability. *Plant Soil* 249(1):117–125
- Rodriguez JA, Nanos N, Grau JM, Gil L, Lopez-Arias M (2008) Multiscale analysis of heavy metal contents in Spanish agricultural topsoils. *Chemosphere* 70(6):1085–1096
- Rodríguez-Iruretagoiena A, Chowdhury R, Gredilla A, deVallejuelo SF, de Diego A, Sarkar SK et al (2016) Uptake and distribution of trace elements in dominant mangrove plants of the Indian Sundarban wetland. *Bull Environ Contam Toxicol* 97(5):721–727
- Sakakibara M, Ohmori Y, Ha NTH, Sano S, Sera K (2011) Phytoremediation of heavy metal-contaminated water and sediment by *Eleocharis acicularis*. *CLEAN—Soil Air Water* 39(8):735–741
- Sakan SM, Đorđević DS, Manojlović DD, Predrag PS (2009) Assessment of heavy metal pollutants accumulation in the Tisza river sediments. *J Environ Manag* 90(11):3382–3390
- Salamova A, Hites RA (2012) Brominated and chlorinated flame retardants in tree bark from around the globe. *Environ Sci Technol* 47(1):349–354
- Salem HM, E A E, Farag A (2000) Heavy metals in drinking water & their environment impact on human health ICEHM2000. Cairo University, Egypt, pp 542–556
- Sarkar SK, Bhattacharya AK (2003) Conservation of biodiversity of the coastal resources of Sundarbans, Northeast India: an integrated approach through environmental education. *Mar Pollut Bull* 47(1):260–264
- Sarkar SK, Bhattacharya BD, Saha S (2007) Spatial variations of zooplankton in Sundarban mangrove wetland, northeastern part of the Bay of Bengal. *ICFAI J Life Sci* 1:7–21
- Sharief MN, Srinivasulu A, Satya Veni P, Rao U MV (2014) Quantification of tannins, antioxidant capacity and antibacterial activities of stem extracts of *Avicennia marina* (L.). *Int J Biol Med Res* 5(1):3869–3873
- Sheoran V, Sheoran AS, Poonia P (2009) Phytomining: a review. *Miner Eng* 22(12):1007–1019
- Silva MRO, Almeida AC, Arruda FVF, Gusmao N (2011) Endophytic fungi from Brazilian mangrove plant *Laguncularia racemosa* (L.) Gaertn.(Combretaceae): their antimicrobial potential. *Sci Against Microb Pathog Commun Curr Res Technol Advances* 2:1260–1266
- Simlai A, Roy A (2012) Analysis of and correlation between phytochemical and antimicrobial constituents of *Cerriops decandra*, a medicinal mangrove plant, from Indian Sundarban estuary. *J Med Plant Res* 6(32):4755–4765
- Sneller FEC, Noordover EC, Ten Bookum WM, Schat H, Bedaux JJ, Verkleij JA (1999) Quantitative relationship between phytochelatin accumulation and growth inhibition during prolonged exposure to cadmium in *Silene vulgaris*. *Ecotoxicology* 8(3):167–175
- Soleimani M, Hajabbasi MA, Afyuni M, Mirlolhi A, Borggaard OK, Holm PE (2010) Effect of endophytic fungi on cadmium tolerance and bioaccumulation by *Festuca arundinacea* and *Festuca pratensis*. *Int J Phytoremediation* 12(6):535–549
- Soliman NF, Nasr SM, Okbah MA (2015) Potential ecological risk of heavy metals in sediments from the Mediterranean coast, Egypt. *J Environ Health Sci Eng* 13(1):1

- Spencer KL, MacLeod CL (2002) Distribution and partitioning of heavy metals in estuarine sediment cores and implications for the use of sediment quality standards. *Hydrol Earth Syst Sci Discuss* 6(6):989–998
- Stoltz E, Greger M (2002) Accumulation properties of As, Cd, Cu, Pb and Zn by four wetland plant species growing on submerged mine tailings. *Environ Exp Bot* 47(3):271–280
- Sun Q, Ye ZH, Wang XR, Wong MH (2007) Cadmium hyperaccumulation leads to an increase of glutathione rather than phytochelatins in the cadmium hyperaccumulator *Sedum alfredii*. *J Plant Physiol* 164(11):1489–1498
- Sun Y, Zhou Q, Wang L, Liu W (2009) Cadmium tolerance and accumulation characteristics of *Bidens pilosa* L. as a potential Cd-hyperaccumulator. *J Hazard Mater* 161(2):808–814
- Sun Y, Zhou Q, Xie X, Liu R (2010) Spatial, sources and risk assessment of heavy metal contamination of urban soils in typical regions of Shenyang, China. *J Hazard Mater* 174(1):455–462
- Sundaramoorthy P, Chidambaram A, Ganesh KS, Unnikannan P, Baskaran L (2010) Chromium stress in paddy: (i) nutrient status of paddy under chromium stress;(ii) phytoremediation of chromium by aquatic and terrestrial weeds. *C R Biol* 333(8):597–607
- Suresh B, Ravishankar GA (2004) Phytoremediation—a novel and promising approach for environmental clean-up. *Crit Rev Biotechnol* 24(2–3):97–124
- Suresh G, Ramasamy V, Sundarajan M, Paramasivam K (2015) Spatial and vertical distributions of heavy metals and their potential toxicity levels in various beach sediments from high-background-radiation area, Kerala, India. *Mar Pollut Bull* 91(1):389–400
- Susarla S, Medina VF, McCutcheon SC (2002) Phytoremediation: an ecological solution to organic chemical contamination. *Ecol Eng* 18(5):647–658
- Tam NF, Wong YS (1997) Accumulation and distribution of heavy metals in a simulated mangrove system treated with sewage. *Hydrobiologia* 352(1–3):67–75
- Tangahu BV, Sheikh Abdullah SR, Basri H, Idris M, Anuar N, Mukhlisin M (2011) A review on heavy metals (As, Pb, and Hg) uptake by plants through phytoremediation. *Int J Chem Eng* 2011:1–31
- Thangavel P, Subbhuraam CV (2004) Phytoextraction: role of hyperaccumulators in metal contaminated soils. *Proc Indian Natl Sci Acad B* 70(1):109–130
- Thomas G, Fernandez TV (1997) Incidence of heavy metals in the mangrove flora and sediments in Kerala, India. *Hydrobiologia* 352:77–87
- Tiwari KK, Dwivedi S, Singh NK, Rai UN, Tripathi RD (2009) Chromium (VI) induced phytotoxicity and oxidative stress in pea (*Pisum sativum* L.): biochemical changes and translocation of essential nutrients. *J Environ Biol* 30(3):389–394
- Trapp S, Köhler A, Larsen LC, Zambrano KC, Karlson U (2001) Phytotoxicity of fresh and weathered diesel and gasoline to willow and poplar trees. *J Soils Sediments* 1(2):71–76
- UNEP (n.d.) Phytoremediation: an environmentally sound technology for pollution prevention, control and remediation. An introductory guide to decision-makers. Newsletter and technical publications Freshwater Management series no. 2, United Nations Environment Programme Division of Technology, Industry, and Economics
- United States Environmental Protection Agency (USEPA) (2000) Introduction to phytoremediation. EPA 600/R-99/107, U.S. Environmental Protection Agency, Office of Research and Development, Cincinnati
- Usman ARA, Alkreda RS, Al-Wabel MI (2013) Heavy metal contamination in sediments and mangroves from the coast of Red Sea: *Avicennia marina* as potential metal bioaccumulator. *Ecotoxicol Environ Saf* 97:263–270
- Vamerali T, Bandiera M, Mosca G (2010) Field crops for phytoremediation of metal-contaminated land. A review. *Environ Chem Lett* 8(1):1–17
- Van der Ent A, Baker AJ, Reeves RD, Pollard AJ, Schat H (2013) Hyperaccumulators of metal and metalloid trace elements: facts and fiction. *Plant Soil* 362(1–2):319–334
- Varol M (2011) Assessment of heavy metal contamination in sediments of the Tigris River (Turkey) using pollution indices and multivariate statistical techniques. *J Hazard Mater* 195:355–364

- Vassilev A, Vangronsveld J, Yordanov I (2002) Cadmium phytoextraction: present state, biological backgrounds and research needs. *Bulg J Plant Physiol* 28(3–4):68–95
- Verkleij JA (1993) The effects of heavy metal stress on higher plants and their use as biomonitors. Plant as bioindicators: indicators of heavy metals in the terrestrial environment. VCH, New York, pp 415–424
- Vesk PA, Nockolds CE, Allaway WG (1999) Metal localization in water hyacinth roots from an urban wetland. *Plant Cell Environ* 22(2):149–158
- Vies J, Briarty LG, Rieley JO (1973) Observations on the swollen lateral roots of the Cyperaceae. *New Phytol* 72(1):167–174
- Walkley A, Black IA (1934) An examination of the Degtjareff method for determining soil organic matter, and a proposed modification of the chromic acid titration method. *Soil Sci* 37(1):29–38
- Walsh JN, Gill R, Thirlwall MF (1997) Dissolution procedures for geological and environmental samples. In: Gill R (ed) *Modern analytical geochemistry, an introduction to quantitative chemical analysis for earth, environmental and materials scientists*, 1st edn. Addison Wesley Longman, Harlow, pp 29–40
- Wang Y, Wisniewski M, Meilan R, Uratsu SL, Cui M, Dandekar A, Fuchigami L (2007) Ectopic expression of Mn-SOD in *Lycopersicon esculentum* leads to enhanced tolerance to salt and oxidative stress. *J Appl Hortic* 9:3–8
- Wang ZH, Feng J, Jiang T, Gu YG (2013) Assessment of metal contamination in surface sediments from Zhelin Bay, the South China Sea. *Mar Pollut Bull* 76(1):383–388
- Watts MJ, Barlow TS, Button M, Sarkar SK, Bhattacharya BD, Alam MA, Gomes A (2013) Arsenic speciation in polychaetes (Annelida) and sediments from the intertidal mudflat of Sundarban mangrove wetland, India. *Environ Geochem Health* 35(1):13–25
- Wei S, Zhou QX (2006) Phytoremediation of cadmium-contaminated soils by *Rorippa globosa* using two-phase planting (5 pp). *Environ Sci Pollut Res* 13(3):151–155
- Wei S, Zhou Q, Wang X (2005) Identification of weed plants excluding the uptake of heavy metals. *Environ Int* 31(6):829–834
- Weis JS, Glover T, Weis P (2004) Interactions of metals affect their distribution in tissues of *Phragmites australis*. *Environ Pollut* 131(3):409–415
- Wu Q, Wang S, Thangavel P, Li Q, Zheng H, Bai J, Qiu R (2011) Phytostabilization potential of *Jatropha curcas* L. in polymetallic acid mine tailings. *Int J Phytoremediation* 13(8):788–804
- Wuana RA, Okieimen FE (2011) Heavy metals in contaminated soils: a review of sources, chemistry, risks and best available strategies for remediation. *Isrn Ecol* 2011(4):1–20
- Yang X, Feng Y, He Z, Stoffella PJ (2005) Molecular mechanisms of heavy metal hyperaccumulation and phytoremediation. *J Trace Elem Med Biol* 18(4):339–353
- Yang B, Zhou M, Shu WS, Lan CY, Ye ZH, Qiu RL, Jie YC, Cui GX, Wong MH (2010) Constitutional tolerance to heavy metals of a fiber crop, ramie (*Boehmeria nivea*), and its potential usage. *Environ Pollut* 158(2):551–558
- Yanqun Z, Yuan L, Jianjun C, Haiyan C, Li Q, Schwartz C (2005) Hyperaccumulation of Pb, Zn and Cd in herbaceous grown on lead–zinc mining area in Yunnan, China. *Environ Int* 31(5):755–762
- Yoon J, Cao X, Zhou Q, Ma LQ (2006) Accumulation of Pb, Cu, and Zn in native plants growing on a contaminated Florida site. *Sci Total Environ* 368(2):456–464
- Zhang X, Xia H, Li Z, Zhuang P, Gao B (2010) Potential of four forage grasses in remediation of Cd and Zn contaminated soils. *Bioresour Technol* 101(6):2063–2066
- Zhao FJ, Lombi E, McGrath SP (2003) Assessing the potential for zinc and cadmium phytoremediation with the hyperaccumulator *Thlaspi caerulescens*. *Plant Soil* 249(1):37–43
- Zhou QX, Song YF (2004) Principles and methods of contaminated soil remediation. Science, Beijing (in Chinese)
- Zhuang P, Yang QW, Wang HB, Shu WS (2007) Phytoextraction of heavy metals by eight plant species in the field. *Water Air Soil Pollut* 184(1–4):235–242