

**NOTICE**

**PORTIONS OF THIS REPORT ARE ILLEGIBLE. It has been reproduced from the best available copy to permit the broadest possible availability.**

**Distribution Categories:  
Chemical Separations Processes for  
Plutonium and Uranium (UC-10)  
Nuclear Waste Management (UC-70)**

ANL-84-45

ARGONNE NATIONAL LABORATORY  
9700 South Cass Avenue  
Argonne, Illinois 60439

ANL--84-45  
DE84 016019

**TRANSURANIC DECONTAMINATION  
OF NITRIC ACID SOLUTIONS BY THE  
TRUEX SOLVENT EXTRACTION PROCESS--  
PRELIMINARY DEVELOPMENT STUDIES**

by

George F. Vandegrift, Ralph A. Leonard,  
and Martin J. Steindler

Chemical Technology Division

and

E. Philip Horwitz, Louis J. Basile,  
Herbert Diamond, Dale G. Kalina,  
and Louis Kaplan

Chemistry Division

July 1984

**DISCLAIMER**

This report was prepared as an account of work sponsored by an agency of the United States Government. Neither the United States Government nor any agency thereof, nor any of their employees, makes any warranty, express or implied, or assumes any legal liability or responsibility for the accuracy, completeness, or usefulness of any information, apparatus, product, or process disclosed, or represents that its use would not infringe privately owned rights. Reference herein to any specific commercial product, process, or service by trade name, trademark, manufacturer, or otherwise does not necessarily constitute or imply its endorsement, recommendation, or favoring by the United States Government or any agency thereof. The views and opinions of authors expressed herein do not necessarily state or reflect those of the United States Government or any agency thereof.

**MASTER**

DISTRIBUTION OF THIS DOCUMENT IS UNLIMITED

TABLE OF CONTENTS

	<u>Page</u>
ABSTRACT . . . . .	1
I. INTRODUCTION . . . . .	1
II. SUMMARY AND CONCLUSIONS . . . . .	3
III. GENERIC TRUEX PROCESS . . . . .	4
A. Extraction/Scrub Step . . . . .	4
B. Strip Step . . . . .	4
C. Solvent Wash . . . . .	6
D. Solvent Cleanup . . . . .	7
IV. TRUEX PROCESS FLOWSHEETS FOR DSW AND CAW FEEDS . . . . .	8
A. Flowsheets . . . . .	8
1. Design Basis . . . . .	8
2. DSW . . . . .	11
3. CAW . . . . .	19
B. Experimental Verification of Reference Flowsheets . . . . .	24
1. Extraction and Scrub Behavior of DSW Components . . . . .	27
2. Stripping Behavior of DSW Components . . . . .	37
3. Relevance of Results to TRU Decontamination . . . . .	41
4. The TRU Product Composition . . . . .	41
C. Modifications for an Improved TRUEX Flowsheet . . . . .	43
V. TRUEX PROCESS CHEMISTRY AND FLOWSHEET FEATURES . . . . .	45
A. Process Flexibility . . . . .	45
1. Nitric Acid Concentration . . . . .	45
2. Oxalic Acid Concentration . . . . .	47
3. Temperature . . . . .	51
4. Tributyl Phosphate . . . . .	51
B. Diluent Properties and Phase Compatibility . . . . .	52
1. Choice of Diluent . . . . .	53
2. TBP Concentration . . . . .	53
3. Nature and Concentration of Bifunctional Extractant . . . . .	54
4. Aqueous Phase Nitric Acid Concentration . . . . .	56
5. Temperature . . . . .	56
6. Other Considerations . . . . .	57
7. Summary of Observations on Third-Phase Formation . . . . .	57

TABLE OF CONTENTS (Contd)

	<u>Page</u>
C. Physical Properties of Extractants . . . . .	57
1. DHDECMP . . . . .	57
2. O $\phi$ D[IB]CMPO . . . . .	58
D. Aqueous Phase Solubilities and Partitioning of Extractants . . . . .	62
1. DHDECMP . . . . .	62
2. O $\phi$ D[IB]CMPO . . . . .	62
E. Chemical and Radiolytic Degradation of TRUEX Process Extractants and Solvent Cleanup . . . . .	65
1. DHDECMP . . . . .	65
2. O $\phi$ D[IB]CMPO . . . . .	65
F. Potential Suppliers and Estimated Unit Prices of Extractants . . . . .	67
G. Evaluation of Extractant Inventory and Loss . . . . .	70
H. Process Equipment for Solvent Extraction . . . . .	71
I. Process Safety . . . . .	74
VI. RECOMMENDATIONS FOR ADDITIONAL R&D . . . . .	76
ACKNOWLEDGMENTS . . . . .	77
REFERENCES . . . . .	78
APPENDIX A. TRUEX FLOWSHEET CALCULATIONS . . . . .	83
APPENDIX B. COUNTERCURRENT TESTS OF TRUEX PROCESS FLOWSHEETS-- EXPERIMENTAL DETAILS . . . . .	89
APPENDIX C. OXALIC ACID COMPLEXING OF CAW AND DSW COMPONENTS . . . . .	107

LIST OF FIGURES

<u>No.</u>	<u>Title</u>	<u>Page</u>
I-1.	Chemical Structures of the TRUEX Bifunctional Extractants . . . . .	2
III-1.	Generic TRUEX Process Flowsheet . . . . .	5
IV-1.	CMP-TRUEX Process Flowsheet for Extraction of TRU Elements from DSW Solution . . . . .	16
IV-2.	CMPO-TRUEX Process Flowsheet for Extraction of TRU Elements from DSW Solution . . . . .	18
IV-3.	CMP-TRUEX Process Flowsheet for Extraction of TRU Elements from CAW Solution . . . . .	22
IV-4.	CMPO-TRUEX Process Flowsheet for Extraction of TRU Elements from CAW Solution . . . . .	25
IV-5.	The Americium Concentration in the Organic and Aqueous Phases of Each Stage of the Countercurrent Experiment at Near-Steady-State . . . . .	28
IV-6.	The Neptunium Concentration in the Organic and Aqueous Phases of Each Stage of the Countercurrent Experiment at Near-Steady-State . . . . .	28
IV-7.	The Plutonium Concentration in the Organic and Aqueous Phases of Each Stage of the Countercurrent Experiment at Near-Steady-State . . . . .	29
IV-8.	The Americium Concentration in a Raffinate Sample vs. the Raffinate Sample Number . . . . .	31
IV-9.	The Neptunium Concentration in a Raffinate Sample vs. the Raffinate Sample Number . . . . .	32
IV-10.	The Raffinate Concentration of <sup>99</sup> Tc vs. the Raffinate Sample Number . . . . .	37
IV-11.	An Improved CMPO-TRUEX Flowsheet for DSW Feed . . . . .	44
V-1.	The Distribution Ratio of Am vs. HNO <sub>3</sub> for the TRUEX Solvents . . . . .	46
V-2.	The Organic-Phase [HNO <sub>3</sub> ] and the Distribution Ratios of Oxalic Acid and Pertechnic Acid vs. the Aqueous-Phase [HNO <sub>3</sub> ] for CMPO-TRUEX Solvent . . . . .	47

LIST OF FIGURES (Contd)

<u>No.</u>	<u>Title</u>	<u>Page</u>
V-3.	Acid Dependency of $D_{Am}$ for 0.25M O $\phi$ D[IB]CMPO in Decalin as a Function of Added TBP . . . . .	52
B-1.	The Experimental Design and Flow Ratios of the Two Countercurrent Experiments . . . . .	98

LIST OF TABLES

<u>No.</u>	<u>Title</u>	<u>Page</u>
IV-1.	Waste Feed Solutions . . . . .	10
IV-2.	Maximum Allowable Am Concentration in an Aqueous Raffinate . . . . .	11
IV-3.	Distribution Coefficients for Various DSW Constituents Using CMPO-TRUEX Process Solvent at 40°C . . . . .	12
IV-4.	Distribution Coefficients for Various CAW Constituents Using CMPO-TRUEX Solvent at 40°C . . . . .	13
IV-5.	Distribution Coefficients for Various CAW or MDSW Constituents Using CMP-TRUEX at 40°C . . . . .	14
IV-6.	CMP-TRUEX Process Flowsheet for Removal of TRU Elements from DSW Solution . . . . .	17
IV-7.	CMPO-TRUEX Process Flowsheet for Removal of TRU Elements from DSW Solution . . . . .	20
IV-8.	CMP-TRUEX Process Flowsheet for the Removal of TRU Elements from CAW Solution . . . . .	23
IV-9.	CMPO-TRUEX Process Flowsheet for Removal of TRU Elements from CAW Solution . . . . .	26
IV-10.	Distribution Ratios of Actinide Elements in Each Stage of the Countercurrent Experiment . . . . .	30
IV-11.	Raffinate Concentrations of Np for the Mini-Countercurrent Experiment . . . . .	30
IV-12.	Distribution Ratio of Neptunium in Each Stage of the Mini-Countercurrent Experiment . . . . .	31
IV-13.	Steady-State Decontamination Factors of TRU Elements and Uranium from Simulated DSW . . . . .	32
IV-14.	Distribution Ratios of Nonfission Products in Each Stage of the Countercurrent Experiment . . . . .	34
IV-15.	Distribution Ratios of Fission Products in Each Stage of the Countercurrent Experiment . . . . .	35
IV-16.	Americium and Neptunium Stripping Behavior . . . . .	38

LIST OF TABLES (Contd)

<u>No.</u>	<u>Title</u>	<u>Page</u>
IV-17.	A Qualitative Summary of the Stripping Behavior of TRU Elements from Loaded CMPO-TRUEX Solvent . . . . .	39
IV-18.	Composition of the Combined Dilute Nitric Acid Strips of Loaded Organic from Cold Countercurrent Run . . . . .	40
IV-19.	Composition of Rare Earths and Yttrium in the Feed and the Combined Strip . . . . .	40
IV-20.	Concentration of TRU Elements and Uranium in Hanford CAW and DSW . . . . .	41
IV-21.	Probable Species in Solidified Raffinate and Their Masses per Volume of Feed . . . . .	42
IV-22.	Summary of Calculations for TRU Content of Solidified Raffinate . . . . .	42
IV-23.	Calculation of the Non-TRU Composition of Solidified TRU Product . . . . .	43
V-1.	Distribution Ratios of DSW Components vs. Aqueous-Phase [H <sub>2</sub> C <sub>2</sub> O <sub>4</sub> ] for a CMP-TRUEX Process Solvent . . . . .	48
V-2.	Distribution Ratios of DSW Components vs. Aqueous-Phase [H <sub>2</sub> C <sub>2</sub> O <sub>4</sub> ] for a CMPO-TRUEX Process Solvent . . . . .	49
V-3.	Distribution Ratios of DSW Components vs. Aqueous-Phase [H <sub>2</sub> C <sub>2</sub> O <sub>4</sub> ] under Conditions Used for Flowsheet Verification by the Batch Countercurrent Experiment . . . . .	50
V-4.	Influence of Temperature on the Extraction of Americium and Europium by TRUEX Process Solvents . . . . .	52
V-5.	Composition of NPH Diluents . . . . .	53
V-6.	Effect of Diluent on the Loading Capacity of CMPO-TRUEX Process Solvents . . . . .	54
V-7.	Loading Capacities of Preconditioned 0.2M O <sub>φ</sub> D[IB]CMPO in Conoco C <sub>12</sub> -C <sub>14</sub> Solutions Containing TPB . . . . .	55
V-8.	Loading Capacity of O <sub>φ</sub> D[IB]CMPO/1.2M TBP Solutions in Norpar-12 . . . . .	55

LIST OF TABLES (Contd)

<u>No.</u>	<u>Title</u>	<u>Page</u>
V-9.	Effect of Diluent on the Loading Capacity of CMPO-TRUEX Process Solvent at 1.0M HNO <sub>3</sub> . . . . .	56
V-10.	Estimated Physical Properties of TRUEX Solvents and Their Constituents . . . . .	59
V-11.	Aqueous Phase Solubility and Partitioning of DHDECMP . . . . .	63
V-12.	Partitioning of CMPO Extractants under Various Conditions . . . . .	64
V-13.	Possible Impurities in Crystallized O <sub>2</sub> D[IB]CMPO . . . . .	68
V-14.	Potential Suppliers of DHDECMP and/or O <sub>2</sub> D[IB]CMPO . . . . .	69
V-15.	Evaluation of Extractant Loss . . . . .	72
V-16.	Comparison of Pulsed Columns and Annular Contrifugal Contactors for Solvent Extraction . . . . .	73
V-17.	Number of Transfer Units (NTU) Required for Americium Extraction . . . . .	74
A-1.	Application of Extraction Factor Analysis to the Elements in the DSW or CAW Solutions with CMPO- or CMP-TRUEX Process Solvents . . . . .	85
B-1.	Composition of the Synthetic DSW: Nonfission Products . . . . .	90
B-2.	Composition of Synthetic DSW Solutions: Fission Products . . . . .	91
B-3.	Composition of Synthetic DSW Feed Solutions: Actinides . . . . .	92
B-4.	Solid Additions in Preparation of Four Liters of Synthetic DSW Solution . . . . .	93
B-5.	Liquid Additions in Preparation of Four Liters of Synthetic DSW Solution . . . . .	94
B-6.	Volume Additions in the Two Countercurrent Experiments . . . . .	99
B-7.	Elements Measured by ICP/AES Analysis and Their Detection Limits . . . . .	102
B-8.	<sup>239</sup> Pu Addition to Samples of <sup>242</sup> Pu for Isotopic Dilution/Mass Spectrometric Analysis . . . . .	104



LIST OF TABLES (Contd)

<u>No.</u>	<u>Title</u>	<u>Page</u>
C-1.	The Hydrogen Ion Activity and the Fraction of $H_2Ox$ , $HOx^-$ , and $Ox^{2-}$ for Uncomplexing Oxalic Acid in Various Nitric Acid Media . . . . .	108
C-2.	Logarithms of Oxalato-Complex Stability Constants for Metal Ions in High Concentration in CAW and DSW . . . . .	109
C-3.	Logarithms of Oxalato-Complex Stability Constants for Actinide Element Species . . . . .	109
C-4.	Logarithms of Oxalato-Complex Stability Constants for Lanthanide Elements and Yttrium Species . . . . .	110
C-5.	Logarithms of Oxalato Complex Stability Constants for Noble Metal Ion and Other Metal Ion Species . . . . .	110
C-6.	Logarithms for Fluoride Complex Stability Constants for Metal Ions in CAW and DSW . . . . .	111
C-7.	Speciation in CAW Solution . . . . .	113

TRANSURANIC DECONTAMINATION OF NITRIC ACID SOLUTIONS BY THE TRUEX  
SOLVENT EXTRACTION PROCESS--PRELIMINARY DEVELOPMENT STUDIES

by

George F. Vandegrift,\* Ralph A. Leonard,\*  
Martin J. Steindler,\* E. Philip Horwitz,†  
Louis J. Basile,† Herbert Diamond,†  
Dale G. Kalina,† and Louis Kaplan†

ABSTRACT

This report summarizes the work that has been performed to date at Argonne National Laboratory on the development of the TRUEX process, a solvent extraction process employing a bifunctional organophosphorous reagent in a PUREX process solvent (tributyl phosphate-normal paraffinic hydrocarbons). The purpose of this extraction process is to separate and concentrate transuranic (TRU) elements from nuclear waste. Assessments were made of the use of two TRUEX solvents: one incorporating the well-studied dihexyl-N, N-diethylcarbamoylmethylphosphonate (DHDECMP) and a second incorporating an extractant with superior properties for a 1M HNO<sub>3</sub> acid feed, octyl(phenyl)-N,N-diisobutylcarbamoylmethylphosphine oxide (O $\phi$ D[IB]CMPO). In this report, conceptual flowsheets for the removal of soluble TRUs from high-level nuclear wastes using these two TRUEX process solvents are presented, and flowsheet features are discussed in detail. The conceptual flowsheet for TRU-element removal from a PUREX waste by the O $\phi$ D[IB]CMPO-TRUEX process solvent was tested in a bench-scale countercurrent experiment, and results of that experiment are presented and discussed. The conclusion of this study is that the TRUEX process is able to separate TRUs from high-level wastes so that the major portion of the solid waste (~99%) can be classified as non-TRU. Areas where more experimentation is needed are listed at the end of the report.

I. INTRODUCTION

Described in this report is a solvent extraction process (named the TRUEX process) that can remove and concentrate soluble actinide elements† (U, Np, Pu, Am) from nitrate solutions under a wide range of chemical compositions for the aqueous media. TRUEX process, which is being developed at Argonne National Laboratory (ANL), employs as the organic solvent a bifunctional organophosphorous extractant dissolved in a PUREX process solvent, tributyl phosphate-normal paraffinic hydrocarbons (TBP-NPH). The effectiveness of the TRUEX process in

\*Chemical Technology Division, ANL.

†Chemistry Division, ANL.

‡If insoluble transuranic elements (e.g., PuO<sub>2</sub>) are present in the feed, there must be a solid-liquid separation to remove the insoluble fraction.

separating and concentrating transuranic (TRU) elements from Hanford current acid waste (CAW)\* and dissolved sludge waste (DSW)† has been the thrust of this ANL effort.

The use of two TRU EX process solvents was examined: one incorporating the well-studied dihexyl-N,N-diethylcarbamoylmethylphosphonate (DHDECMP) and a second incorporating an extractant with superior properties for a 1M HNO<sub>3</sub> acid feed, namely, octyl(phenyl)-N,N-diisobutylcarbamoylmethylphosphine oxide (OφD[IB]CMPO). Throughout this report, the former organic solvent is designated CMP-TRU EX, the latter CMPO-TRU EX. The chemical structures of these compounds are illustrated in Fig. I-1.

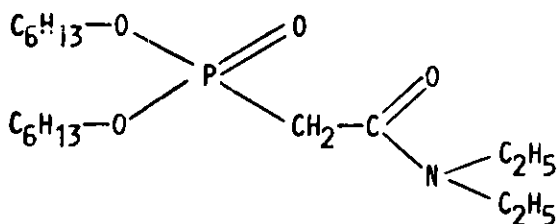

DHDECMP

Fig. I-1.

Chemical Structures of the TRU EX  
Bifunctional Extractants

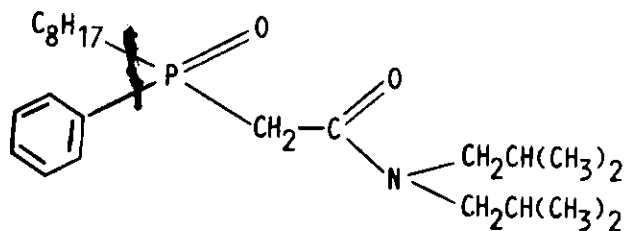

OφD[IB]CMPO

\*CAW represents typical PUREX high-level acid waste that has been denitrated by sugar.

†At Hanford, PUREX process CAW is made alkaline and stored in double-shell tanks. The neutralized waste contains a solid phase (sludge) with almost all of the <sup>90</sup>Sr and actinide elements in the waste. Dissolved sludge waste refers to a solution that might be produced if the sludge, when eventually retrieved, were to be dissolved by oxalic acid and/or nitric acid. Current waste management plans at Hanford call for retrieval and vitrification of the sludge without production of the DSW.

## II. SUMMARY AND CONCLUSIONS

Four reference TRUEX process flowsheets were devised for TRU removal from CAW and DSW by either CMP-TRUEX or CMPO-TRUEX process solvents. These flowsheets were calculated from batch distribution ratios with simulated waste solutions. Based on these reference flowsheets, the number of requisite extraction stages to reduce TRU element concentrations to or below 100 nCi/g and 100 nCi/g solidified raffinate was calculated. Appropriate conditions for stripping the loaded organic solvent were also determined from batch distribution ratios.

The CMPO-TRUEX process flowsheet for use with DSW was successfully demonstrated in an extensive batch countercurrent test using synthetic DSW spiked with appropriate radionuclides. This batch countercurrent experiment demonstrated convincingly that the CMPO-TRUEX flowsheet would reduce soluble TRU element concentration below 100 nCi/g in the solidified raffinate (~99% of the mass of the solidified feed would be non-TRU).

In this report, pertinent data and results are presented for important TRUEX process factors, including (1) process flexibility, (2) diluent properties and phase compatibility, (3) physical properties of extractants, (4) aqueous phase solubilities and partitioning of extractants, and (5) chemical and radiolytic degradation of extractants and solvent cleanup. Also discussed are potential suppliers and estimated unit prices of extractants, extractant inventory and loss, process equipment for solvent extraction, and process safety.

For use with either DSW or CAW solutions, the CMPO-TRUEX flowsheet is preferred over that of CMP-TRUEX because:

- The CMPO-TRUEX solvent is more efficient than CMP-TRUEX and, therefore, requires fewer extraction stages.
- CMPO-TRUEX does not require the addition of  $\text{Al}(\text{NO}_3)_3$  to DSW to remove soluble TRU.
- The extracting power of CMPO-TRUEX solvent is far less affected by  $\text{HNO}_3$  concentrations in the range of 0.5-6M nitrate than is that of CMP-TRUEX; great variations in feed composition are easily handled.
- $\text{O}\phi\text{D}[\text{IB}]\text{CMPO}$  is easier to purify than DHDECMP.
- The much lower aqueous phase solubility and much higher chemical and radiolytic stability of  $\text{O}\phi\text{D}[\text{IB}]\text{CMPO}$  make it an economic favorite over DHDECMP, even though it has a higher unit price.

### III. GENERIC TRUEX PROCESS

Development work on the TRUEX process has been centered thus far on two feed solutions, CAW and DSW. Because of its flexibility, however, the TRUEX process shows potential for removing and concentrating TRU elements from various  $\text{HNO}_3$  solutions. A generic TRUEX process flowsheet for handling a wide variety of feeds is presented in Fig. III-1. Important flowsheet features are called out in the following discussion.

#### A. Extraction/Scrub Step

- The choice of which bifunctional organophosphorus extractant to use is dependent primarily on the nitric acid concentration of the feed and, to a lesser extent, on the total concentration of dissolved nitrate ion. Because, in using  $\text{O}_4\text{D}[\text{IB}]\text{CMPO}$ , distribution ratios of TRU elements are insensitive to  $[\text{HNO}_3]$  in the range of 0.7 to  $5\text{M}$ , it is the preferred extractant in this  $[\text{HNO}_3]$  range. Above  $3\text{M}$   $\text{HNO}_3$ , the CMP-TRUEX solvent becomes more selective for TRU elements than the CMPO-TRUEX solvent; the latter solvent, however, still has higher distribution ratios for TRU element extraction.

- The ratio of [TBP] to  $[\text{O}_4\text{D}[\text{IB}]\text{CMPO}]$  or [DHDECMP] in the TRUEX process solvent is set primarily to avoid third-phase formation. Requirements of low temperature, high  $[\text{HNO}_3]$ , and high solvent loading necessitate the highest ratio of [TBP] to  $[\text{O}_4\text{D}[\text{IB}]\text{CMPO}]$  or [DHDECMP].

- Oxalic acid is added to feeds containing fission products to improve selectivity of the extractant for TRU elements.

- High concentrations of inerts (e.g., Na, Al, Fe, Cr, Ni,  $\text{SO}_4^{2-}$ ,  $\text{F}^-$ ) generally require no special adjustments in feed composition.

- The fate of Tc in the TRUEX process is dependent on the feed composition and on O/A flow ratios. Technetium extractability is increased by the presence of rare earth elements and has a parabolic dependency on the aqueous phase acidity, reaching a maximum in the range of  $0.25\text{-}1.0\text{M}$   $\text{HNO}_3$ .

- Scrub composition depends primarily on the desired purity of TRU elements and on the concentration of fission products in the feed. Oxalic acid in the scrub solution is useful for removing Zr and Mo from the loaded organic phase. The presence of  $\text{H}_2\text{C}_2\text{O}_4$  forces the use of higher  $\text{HNO}_3$  concentrations in the scrub solution and may necessitate the use of a second scrub section to remove  $\text{H}_2\text{C}_2\text{O}_4$  and  $\text{HNO}_3$  from the loaded organic before stripping.

- If a second scrub section is necessary, the back extraction of  $\text{H}_2\text{C}_2\text{O}_4$  can be facilitated by adding Fe(III) to that scrub solution.

#### B. Strip Step

- The required  $[\text{HNO}_3]$  of the strip solution is dependent on which TRUEX process solvent is used. Because DHDECMP is a less powerful extractant than



Footnotes

- <sup>a</sup>Either 0.1-0.3M O $\phi$ D[IB]CMPO/1.0-1.4M TBP/NPH or 0.4-0.5M DHDECMP/1.2-1.4M TBP/NPH. Ranges of the bifunctional organophosphorus extractants and TBP are functions of the diluent. An NPH mixture with a lower average carbon chain length will allow the use of higher concentrations of extractant and lower concentrations of TBP without third-phase formation problems.
- <sup>b</sup>Actinides = soluble species of U, Np, Pu, and Am.
- <sup>c</sup>F.P.R.E. = fission product rare earths.
- <sup>d</sup>F.P. = fission products (except F.P.R.E.).
- <sup>e</sup>For example, Na<sup>+</sup>, Al<sup>3+</sup>, Fe<sup>3+</sup>, Cr<sup>3+</sup>, Ni<sup>2+</sup>, SO<sub>4</sub><sup>2-</sup>, F<sup>-</sup>.
- <sup>f</sup>Lower HNO<sub>3</sub> concentration for the CMPO-TRUEX process; higher concentrations for the CMP-TRUEX process. Oxalic acid only required when fission products are in the feed.
- <sup>g</sup>Lower concentrations of HNO<sub>3</sub> for CMPO-TRUEX processes; higher ones for CMP-TRUEX processes.
- <sup>h</sup>Hydroxylammonium nitrate.
- <sup>i</sup>The actinide activity level in this stream is less than 100 nCi/g of solidified waste form.
- <sup>j</sup>The solvent extraction behavior of technetium is greatly dependent on the TRUEX process solvent and the relative stream flows.
- <sup>k</sup>Non-TRU waste stream.
- <sup>l</sup>An optional operation where resin would be removed for recycle or disposal.

O $\phi$ D[IB]CMPO, TRU elements can be stripped from CMP-TRUEX process solvent at higher [HNO<sub>3</sub>].

- Stripping of Am and Pu is much easier than stripping Np, and far easier than stripping U.
- The addition of HAN to the stripping solution reduces Pu(IV) to Pu(III) and thus increases the ability to strip Pu.
- It may be possible to selectively strip Am (III) from Pu (IV) in a two-part stripping operation by (1) stripping Am with dilute HNO<sub>3</sub> followed by (2) a dilute HNO<sub>3</sub>-HAN strip of Pu.

C. Solvent Wash

- An oxalic acid wash will be necessary to cleanse the spent solvent of elements not removed by stripping (most of the U and traces of Np, Pu, and Zr).
- The waste solution from this process step would generally be non-TRU.

#### D. Solvent Cleanup

- Aqueous NaOH or Na<sub>2</sub>CO<sub>3</sub> washes are not sufficient to remove the high molecular weight, acidic compounds generated by the hydrolysis/radiolysis of DHDECMP and O<sub>4</sub>D[IB]CMPO and their associated impurities, but alkaline washing would be useful in removing the dibutylphosphoric acid produced from TBP degradation.

- An optional operation employing macroporous anion exchange resin (in the OH<sup>-</sup> form) should be effective in removing the acidic degradation products of high molecular weight in the CMP-TRUEX and CMPO-TRUEX process solvents.

- The spent anion exchange resin could either be recycled or disposed of as non-TRU waste.



#### IV. TRUEX PROCESS FLOWSHEETS FOR DSW AND CAW FEEDS

##### A. Flowsheets

###### 1. Design Basis

The basis for the flowsheet designs given in Sections IV.A.2 and 3 is described in this section. The factors considered in flowsheet design were process constraints, given process parameters, calculated process parameters, and distribution coefficient data. Computational procedures are given in Appendix A.

###### a. Process Constraints

- The first process constraint is to separate enough of the TRU elements from the bulk of the waste to make it non-TRU waste.

- The second process constraint is to keep the organic-to-aqueous (O/A) ratio within the ranges typically used for good operation of pulsed columns. This O/A range is 0.5 to 2.5 for the extraction section, 0.33 to 10 for the scrub section, and 0.5 to 4 for the stripping section. The O/A ratio is not a constraint with the use of annular centrifugal contactors since such contactors work well over a wide range of O/A flow ratios.

- A further constraint to the O/A ratio comes from the dynamics of the process itself. Two competing factors are at work. On the one hand, the O/A ratio should be low to minimize the organic phase inventory, since the extractant is expensive. On the other hand, the number of extraction stages should be minimized by keeping the O/A ratio high. Since the volume of extractant in the extraction units will be less than 10% of the extractant needed for the process (see Section V), the number of stages was minimized by making the O/A ratio as large as possible consistent with the other constraints. In fact, limiting the amount of Pd, Zr, and Mo in the organic phase (discussed in the following constraint) actually fixed the O/A flow ratio in the extraction section for all flowsheets.

- A fourth constraint is to minimize the concentration of Pd, Zr, and Mo in the organic effluent (product) from the extraction/scrub unit. These metal ions cause problems when the organic product is fed to the stripping unit; scums form and greatly retard the coalescence of the dispersion. To prevent this, the concentration of these metal ions is kept low, i.e.,  $<1 \times 10^{-4}M$  in the organic product. This is done by adding oxalic acid, which keeps these metal ions in the aqueous phase as inextractable oxalato-complexes.

- A fifth constraint is to minimize the concentration of oxalate in the organic effluent (product) from the extraction/scrub unit so that lanthanide oxalates do not precipitate when the organic phase is stripped. The process should be operated so that the concentration of oxalate ions in the organic product is less than that of the lanthanide ions. Since the concentration of rare earths in the organic product is about 0.02M, the maximum oxalate concentration was set at 0.001M, 5% of the rare earth concentration. When O<sub>2</sub>D[IB]CMPO is the extractant, oxalate is added to the first aqueous scrub feed so that Pd, Zr, and Mo are kept out of the organic product. Then a second scrub section with a low nitric acid concentration (0.5M) and a small amount of Fe (0.01M) is used to obtain the desired low oxalate concentration in the

organic product. When DHDECMP is the extractant, a high nitric acid concentration in the scrub is required to maintain a reasonably high distribution coefficient for the americium. The oxalic acid distribution coefficient is much lower at the higher nitric acid concentration; therefore, only one scrub section is needed.

- A sixth constraint is to keep the metal ion loading in the organic phase at a level where a second organic phase will not form. As a design guide, the maximum loading of the solvent was kept to 50% of that required to form a second organic phase. This was done by choosing the proper diluent and concentrations of the TBP and each bifunctional extractant.

- A final constraint (perhaps more of a guideline than a constraint) is to keep technetium with the organic product from the extraction/scrub unit.

#### b. Given Process Parameters

For the flowsheets described below, the organic phase extractant is either DHDECMP or  $O\phi D[IB]CMPO$ . The diluent is a commercial mixture of NPH with carbon chain lengths in the range of 12 to 14, Conoco 12-14. For the CMP-TRUEX process solvent, the DHDECMP extractant has a concentration of 0.4M and is modified by adding TBP with a concentration of 1.2M. Since commercial DHDECMP actually contains 86% DHDECMP, with the other 14% being a neutral species with properties much like TBP, only 1.1M TBP is added to make up the CMP-TRUEX solvent; the additional 0.1M concentration of TBP-like material comes from the commercial DHDECMP. Thus, the 1.2M value for TBP in the CMP is actually an effective TBP concentration. For the CMPO-TRUEX process solvent, the  $O\phi D[IB]CMPO$  extractant has a concentration of 0.2M and is modified by adding TBP with a concentration of 1.4M.

In the four flowsheets given in Sections IV.A.2 and 3, three waste solutions are used as aqueous feed streams. These three waste feed solutions are identified in Table IV-1, with the concentrations of the major components given. When DHDECMP is used with DSW to which  $Al(NO_3)_3$  has been added, the distribution coefficient for Am is higher than would otherwise be the case. This greatly helps in the efficient removal of Am from the feed. Oxalic acid is added to the CAW to give the concentration shown in Table IV-1. For DSW, oxalic acid will already be present since oxalic acid is used to dissolve the sludge.

All flowsheets are intended to be operated at 40°C.

#### c. Calculated Process Parameters

Since the concentration of americium in terms of Ci/L is large relative to Np and Pu, it is the key component in TRU removal. For this reason, the maximum allowable TRU concentration in the aqueous raffinate was calculated in terms of the maximum allowable Am concentration. The results, given in Table IV-2, show that DSW requires a lower concentration in the raffinate than does the modified DSW (MDSW) or CAW. This is the result of the higher aluminum nitrate content of the MDSW and CAW, which dilutes the TRU concentration. For the same reason, the required decontamination factor (D.F.) is less for MDSW and CAW than for DSW. If the solids are metal nitrates rather

Table IV-1. Waste Feed Solutions

	Concentration, M		
	DSW	Modified DSW <sup>a</sup>	CAW
<b>Acids</b>			
HNO <sub>3</sub>	1.0	1.0	1.0
H <sub>2</sub> C <sub>2</sub> O <sub>4</sub>	0.2	0.2	0.18
<b>Non-Fission Product Cations</b>			
Fe	0.15	0.136	0.13
Al	0.046	0.70	0.71
Na	0.15	0.136	0.18
Others <sup>b</sup> (Cr, Ni, Be, <sup>c</sup> Ca, Cu, Mg, Mn, Si, <sup>c</sup> Ti)	0.031	0.028	0.036
<b>Anions</b>			
NO <sub>3</sub> <sup>-d</sup>	1.9	3.8	3.0
F <sup>-</sup>	0.008	0.007	0.15
Others <sup>b</sup> (SO <sub>4</sub> <sup>2-</sup> , PO <sub>4</sub> <sup>3-</sup> <sup>c</sup> )	0.012	0.011	0.27
<b>Fission Products</b>			
Zr	5.6E-3	5.1E-3	5.6E-3
Mo	1.8E-4	1.6E-4	1.8E-4
Y	7.3E-4	6.6E-4	7.3E-4
Ru	2.1E-3	1.9E-3	2.1E-3
Pd	5.4E-4	4.9E-4	5.4E-4
Tc <sup>c</sup>	0.0	0.0	9.8E-4
Others <sup>b</sup> (Cd, Nb, Se, Rb, <sup>c</sup> Sr, Rh, Ag, Sn, Sb, Te, Cs, <sup>c</sup> Ba)	3.6E-3	3.3E-3	6.5E-3
<b>Fission Product Rare Earths</b>			
La	1.0E-3	9.1E-4	1.0E-3
Ce	2.4E-3	2.2E-3	2.4E-3
Pr	9.2E-4	8.4E-4	9.2E-4
Nd	2.7E-3	2.5E-3	2.7E-3
Others <sup>b</sup> (Pm, Sm, Eu, Gd)	7.4E-4	6.7E-4	7.4E-4
<b>Actinides Including TRU</b>			
Am	1.7E-4	1.5E-4	1.7E-4
Others <sup>b</sup> (U, Np, Pu)	3.4E-4	3.1E-4	3.4E-4

<sup>a</sup>Al(NO<sub>3</sub>)<sub>3</sub>·9H<sub>2</sub>O added when processing DSW with DHDECMP extractant.

<sup>b</sup>The sum of the concentrations of all constituents in this category.

<sup>c</sup>This constituent is not found in DSW waste feed solutions.

<sup>d</sup>Includes nitrate from nitric acid.

Table IV-2. Maximum Allowable Am Concentration in the Aqueous Raffinate

Type of Aqueous Feed	Level of Decontamination, <sup>a</sup> nCi/g	Am <sup>b</sup> in Aqueous Raffinate, <u>M</u>	Am Decontamination Factor in Extraction Section
DSW	100	$3 \times 10^{-9}$	$7 \times 10^4$
	1000	$3 \times 10^{-8}$	$7 \times 10^3$
MDSW, <sup>c</sup> CAW	100	$5 \times 10^{-9}$	$3 \times 10^4$
	1000	$5 \times 10^{-8}$	$3 \times 10^3$

<sup>a</sup>In the calculation, it is assumed that the products are present as solid metal oxides.

<sup>b</sup>Americium concentration in aqueous waste solution is  $1.7 \times 10^{-4}$  M.

<sup>c</sup>Modified DSW as given in Table IV-1.

than metal oxides, the required D.F. will be lower by a factor of about two for all cases. If concentrated aqueous raffinate is mixed with grout such that the grout contains 12.5 to 25 wt % solids from the raffinate, the required D.F. for TRU removal will be lower by another factor of 4 to 8. For the flowsheets given in Sections IV.A.2 and 3, the D.F.'s given in Table IV-2 were used.

For the flowsheets, it is assumed that the organic feed to the extraction/scrub unit has only the organic diluent and extractants. Thus, the solvent stripping and washing operations are treated as if they removed all the metal ions. The hardest metal ions to remove will be those that are extracted more easily. Americium is of particular interest because its concentration in the aqueous raffinate must be reduced to such a low value that the raffinate can be converted into non-TRU waste. Using the McCabe-Thiele method of analysis discussed in Appendix A, one can show that the metal ion concentration in the organic feed is effectively zero if it is lower than the desired concentration in the aqueous raffinate by the factor  $(R_e D)/10$ , where  $R_e$  is the O/A flow ratio in the extraction section and D is the distribution coefficient for the metal ion.

#### d. Distribution Coefficient Data

The distribution coefficient data used to calculate conditions for the the various flowsheets are given in Tables IV-3 to -5.

## 2. DSW

### a. Introduction

Flowsheets are presented for removal of TRU elements from DSW solution by using CMP- and CMPO-TRUOX process solvents. For each flowsheet, a six-stage scrub section is assumed. If two scrub sections (split scrub) are used, each scrub section has three stages. With six scrub stages and six or more extraction stages, the elements in Regimes II and IV (the separation regimes, from I to V, and the constituents in each regime are presented in Appendix A) are concentrated predominantly (90 % to 95%) in the organic and aqueous effluents, respectively.

Table IV-3. Distribution Coefficients for Various DSW Constituents Using CMPO-TRUOX Process Solvent at 40°C

	Distribution Coefficients <sup>a</sup>				
	Extraction			Scrub	
	Other Stages	Next to Feed Stage	Feed Stage	First	Second
<b>Acids</b>					
HNO <sub>3</sub>			0.3		
H <sub>2</sub> C <sub>2</sub> O <sub>4</sub>			0.06		
<b>Non-Fission Product Cations</b>					
Fe			0.04		
Cr			<0.001		
Ni			<0.001		
Al			<0.01		
Na			<0.001		
Ca			<0.01		
Cu			<0.01		
Mg			(<0.01) <sup>b</sup>		
Mn			<0.01		
Ti			(<0.01) <sup>b</sup>		
<b>Fission Products</b>					
Zr			0.04		
Cd			<0.1		
Nb			(0.04) <sup>b</sup>		
Mo			0.28		
Se			(<0.01) <sup>b</sup>		
Sr			<0.01		
Y	4.0	3.3	1.8	1.97	1.0
Ru	0.10	0.15	0.3	4	4
Rh			<0.1		
Pd	0.40	0.40	0.50	0.5	0.5
Ag			<0.1		
Sn			(<0.01) <sup>b</sup>		
Sb			(<0.01) <sup>b</sup>		
Te			(<0.01) <sup>b</sup>		
Ba			<0.01		
Tc	2.5	2.5	3.0	3.0	3.3
<b>Fission Product Rare Earths</b>					
La	6.4	5.4	2.9	3.3	1.7
Ce	11	8.8	4.8	5.2	2.6
Pr	12	10	5.4	5.9	3.0
Nd	10.3	8.6	4.6	5.1	2.5
Pm	(8.8) <sup>b</sup>	(8.6) <sup>b</sup>	(4.6) <sup>b</sup>	(5.1) <sup>b</sup>	(2.5) <sup>b</sup>
Sm	7.5	8.6	4.6	5.1	2.5
Eu	9.0	7.5	4.1	4.5	2.2
Gd	5.8	4.8	2.6	2.9	1.5
<b>Actinides Including TRU</b>					
U			>100		
Np			>100		
Pu			>100		
Am	12	10	5.4	6.0	3

<sup>a</sup>If one value applies to all stages, this value is shown in the feed stage column.

<sup>b</sup>Estimated.

Table IV-4. Distribution Coefficients for Various CAW Constituents Using CMPO-TRUEX Solvent at 40°C

	Distribution Coefficients <sup>a</sup>				
	Extraction			Scrub	
	Other Stages	Next to Feed Stage	Feed Stage	First	Second
<b>Acids</b>					
HNO <sub>3</sub>			0.3		
H <sub>2</sub> C <sub>2</sub> O <sub>4</sub>			0.06		
<b>Non-Fission Product Cations</b>					
Fe			0.048		
Cr			<0.001		
Ni			<0.001		
Al			<0.01		
Be			(<0.01) <sup>b</sup>		
Na			<0.001		
Ca			<0.01		
Cu			<0.01		
Mg			(<0.01) <sup>b</sup>		
Mn			<0.01		
Si			(<0.01) <sup>b</sup>		
Ti			(<0.01) <sup>b</sup>		
<b>Fission Products</b>					
Zr			0.048		
Cd			<0.1		
Nb			(0.048) <sup>b</sup>		
Mo	0.34	0.34	0.34	0.28	0.28
Se			(<0.01) <sup>b</sup>		
Rb			(<0.01) <sup>b</sup>		
Sr			<0.01		
Y	4.8	3.96	2.16	1.97	1.0
Ru	0.12	0.18	0.36	4	4
Rh			<0.1		
Pd	0.48	0.48	0.60	0.5	0.5
Ag			<0.1		
Sn			(<0.01) <sup>b</sup>		
Sb			(<0.01) <sup>b</sup>		
Te			(<0.01) <sup>b</sup>		
Cs			(<0.01) <sup>b</sup>		
Ba			<0.01		
Tc	3.0	3.0	3.6	3.0	3.3
<b>Fission Product Rare Earths</b>					
La	7.7	6.5	3.5	3.3	1.7
Ce	13.2	10.6	5.8	5.2	2.6
Pr	14.4	12.0	6.5	5.9	3.0
Nd	12.4	10.3	5.5	5.1	2.5
Pm	(10.6) <sup>b</sup>	(10.3) <sup>b</sup>	(5.5) <sup>b</sup>	(5.1) <sup>b</sup>	(2.5) <sup>b</sup>
Sm	9.0	10.3	5.5	5.1	2.5
Eu	10.8	9.0	4.9	4.5	2.2
Gd	7.0	5.8	3.1	2.9	1.5
<b>Actinides Including TRU</b>					
U			>100		
Np			>100		
Pu			>100		
Am	4	12.0	6.5	6.0	3

<sup>a</sup>If one value applies to all stages, this value is shown in the feed stage column.

<sup>b</sup>Estimated.

Table IV-5. Distribution Coefficients for Various CAW or MDSW Constituents Using CMP-TRUEX at 40°C

	Distribution Coefficients <sup>a</sup>	
	Extraction	Scrub
<b>Acids</b>		
HNO <sub>3</sub>	0.3	
H <sub>2</sub> C <sub>2</sub> O <sub>4</sub>	0.06	
<b>Non-Fission Product Cations</b>		
Fe	0.0035	
Cr	<0.001	
Ni	<0.001	
Al	<0.001	
Be	(<0.01) <sup>b</sup>	
Na	(<0.01) <sup>b</sup>	
Ca	<0.01	
Cu	<0.001	
Mg	(<0.01) <sup>b</sup>	
Mn	<0.001	
Si	(<0.01) <sup>b</sup>	
Ti	(<0.01) <sup>b</sup>	
<b>Fission Products</b>		
Zr	0.035	
Cd	<0.01	
Nb	(<0.01) <sup>b</sup>	
Mo	0.025	
Se	(<0.01) <sup>b</sup>	
Rb	(<0.01) <sup>b</sup>	
Sr	<0.01	
Y	3.0	
Ru	0.3	
Rh	<0.01	
Pd	0.63	
Ag	<0.01	
Sn	(<0.01) <sup>b</sup>	
Sb	(<0.01) <sup>b</sup>	
Te	(<0.01) <sup>b</sup>	
Cs	(<0.01) <sup>b</sup>	
Ba	<0.01	
Tc	1.0	0.15
<b>Fission Product Rare Earths</b>		
La	3.8	1.9
Ce	4.1	2.0
Pr	4.1	2.0
Nd	4.1	2.0
Pm	(3.8) <sup>b</sup>	(1.8) <sup>b</sup>
Sm	3.5	1.7
Eu	3.1	1.5
Gd	2.0	1.0
<b>Actinides Including TRU</b>		
U	>4	
Np	>4	
Pu	>4	
Am	4.0	2.0

<sup>a</sup>If one value applies to all stages, this value is shown in the extraction column.

<sup>b</sup>Estimated

b. DHDECMP Extractant

Table IV-5 lists the distribution coefficient data used to derive the flowsheet for CMP-TRUEX with modified DSW solution (MDSW) (Fig. IV-1). The MDSW solution has been prepared from the DSW feed by the addition of  $0.7\text{M Al(NO}_3)_3$  so that the distribution coefficient for americium is four rather than one. Because addition of  $\text{Al(NO}_3)_3$  increases the volume of the DSW feed by about 10%, concentrated  $\text{HNO}_3$  is also added to keep the feed  $\text{HNO}_3$  concentration at  $1.0\text{M}$ .

(1) TRU Decontamination

The process flowsheet, Fig. IV-1 and Table IV-6, will remove enough of the soluble TRU elements from the DSW feed to make its TRU concentration less than  $100\text{ nCi/g}$ . The process requires 14 extraction stages and 6 scrub stages. The large number of extraction stages is required because of the low extraction factor for the americium. The extraction factor could be made higher by increasing the O/A flow ratio; but, as shown in Table A-1 (Appendix A), a higher O/A ratio allows palladium into the organic product.

To achieve a TRU concentration below  $1000\text{ nCi/g}$  in the DSW solution, 11 extraction stages and 6 scrub stages are sufficient.

(2) Stripping of TRU Elements

Americium is easy to strip from the CMP-TRUEX solvent. Typical stripping conditions include an O/A flow ratio ( $R_{st}$ ) of 2,  $0.1\text{M HNO}_3$ , and  $0.01\text{M HAN}$  (hydroxylammonium nitrate) to maintain reducing conditions in the scrub. The distribution coefficient for americium under these stripping conditions is 0.0085. To effectively strip the americium from the organic phase, the stripping unit is designed to provide a decontamination factor which is ten times greater than that for the corresponding extraction section. (This decontamination factor for stripping can actually be slightly lower, as noted in Section IV.A.1.c above.) Thus, when it is desired to have an Am concentration in the aqueous raffinate below  $5 \times 10^{-8}\text{M}$  (below  $1000\text{ nCi}$  of TRU per gram of solid raffinate as metal oxide), the Am concentration in the organic feed to the extraction/scrub unit should be  $5 \times 10^{-9}\text{M}$ . Calculations with Eq. A-2 (Appendix A) indicate that four strip stages are required to achieve this Am concentration in the organic feed for the extraction/scrub unit. Five stages are required if the Am concentration in the aqueous raffinate is to be below  $5 \times 10^{-9}\text{M}$  (below  $100\text{ nCi}$  of TRU per gram of solid raffinate as metal oxide). Since the organic feed to the strip unit contains  $\text{HNO}_3$ , it may be necessary to have one or two additional strip stages.

c. O $\phi$ D[IB]CMPO Extractant

Table IV-3 lists the distribution coefficient data used to derive the CMPO-TRUEX flowsheet for use with DSW solution (Fig. IV-2).

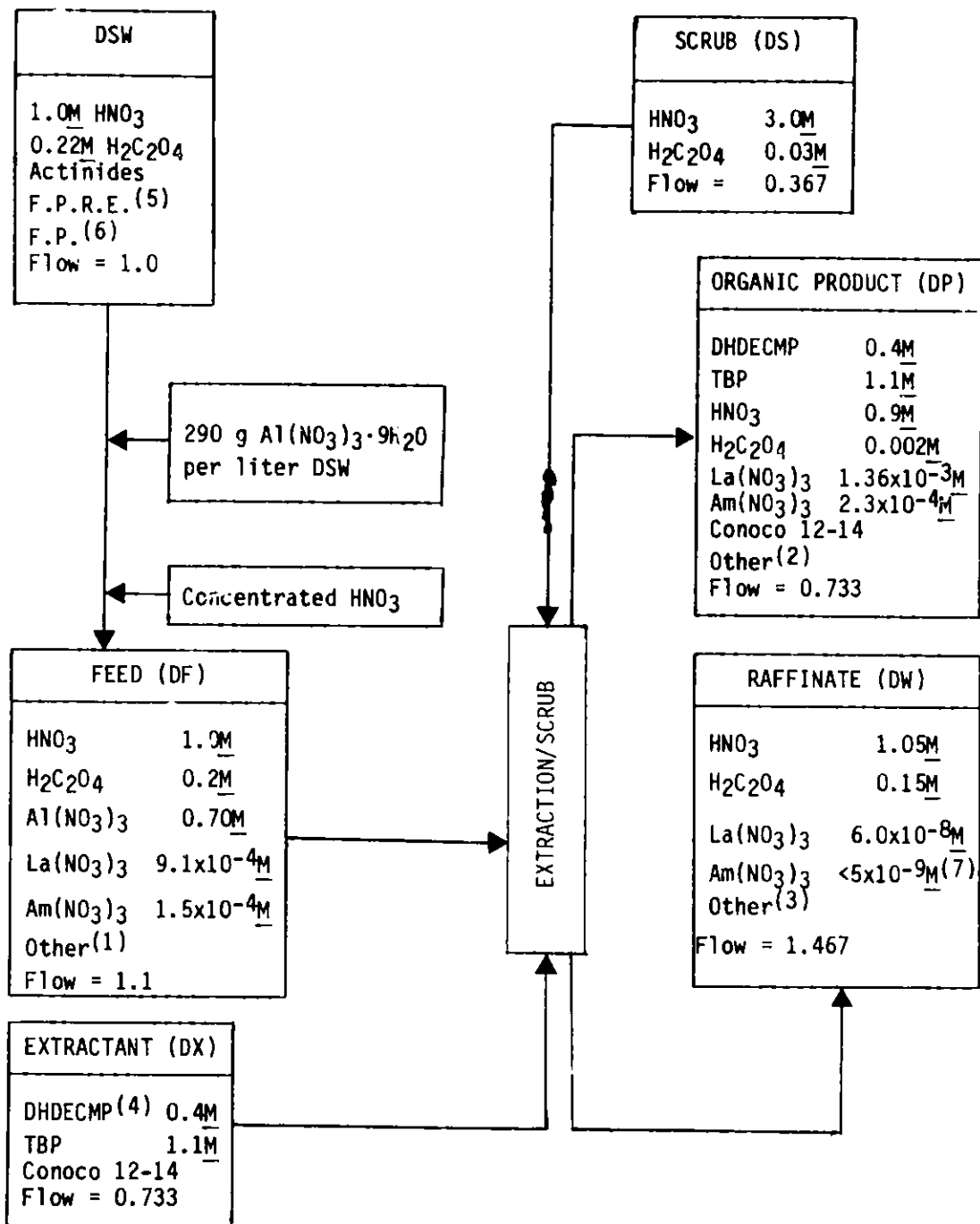

**Notes**

1. Other cations and anions from fuel, cladding, and fission products in DSW as listed in Table IV-6.
2. All other lanthanides, actinides, and yttrium as listed in Table IV-6.
3. All metal ions not in organic effluent including almost all the non-rare earth fission products (see Table IV-6). Low americium concentration is based on having 14 extraction stages.
4. Added as the ~86% material.
5. Fission Product Rare Earths.
6. Fission Products.
7. Equivalent to <100 nCi/g solidified raffinate as metal oxides.

Fig. IV-1. CMP-TRUEX Process Flowsheet for Extraction of TRU Elements from DSW Solutions

Table IV-6. CMP-TRUEX Process Flowsheet for Removal of TRU Elements from DSW Solution

	DF	DS	DX	DW	DP	Notes
Phase	Aqueous	Aqueous	Organic	Aqueous	Organic	
Rel. Vol. Flow	1.1	0.367	0.733	1.467	0.733	
<b>Acids</b>						
HNO <sub>3</sub> , <u>M</u>	1.0	3.0	0.0	1.05	0.9	a
H <sub>2</sub> C <sub>2</sub> O <sub>4</sub> , <u>M</u>	0.2	0.03	0.0	0.157	0.0018	b
<b>Non-Fission Product Cations</b>						
Fe, <u>M</u>	0.136	0.0	0.0	0.102	0.0	
Cr, <u>M</u>	0.0122	0.0	0.0	0.009	0.0	
Ni, <u>M</u>	0.007	0.0	0.0	0.005	0.0	
Al, <u>M</u>	0.70	0.0	0.0	0.525	0.0	
Na, <u>M</u>	0.136	0.0	0.0	0.102	0.0	
Ca, <u>M</u>	0.00123	0.0	0.0	0.0009	0.0	
Cu, <u>M</u>	1.6E-3	0.0	0.0	1.2E-3	0.0	
Mg, <u>M</u>	1.5E-3	0.0	0.0	1.1E-3	0.0	
Mn, <u>M</u>	4.1E-3	0.0	0.0	3.1E-3	0.0	
Ti, <u>M</u>	1.8E-5	0.0	0.0	1.4E-5	0.0	
<b>Anions</b>						
NO <sub>3</sub> <sup>-</sup> , <u>M</u>	3.8	3.0	0.0	3.1	0.956	c
F <sup>-</sup> , <u>M</u>	0.007	0.0	0.0	0.005	0.0	
SO <sub>4</sub> <sup>2-</sup> , <u>M</u>	0.011	0.0	0.0	0.008	0.0	
<b>Fission Products</b>						
Zr, <u>M</u>	5.1E-3	0.0	0.0	3.8E-3	0.0	
Cd, <u>M</u>	4.5E-5	0.0	0.0	3.4E-5	0.0	
Nb, <u>M</u>	1.3E-5	0.0	0.0	1.0E-5	0.0	
Mo, <u>M</u>	1.6E-4	0.0	0.0	1.2E-4	0.0	
Se, <u>M</u>	8.6E-5	0.0	0.0	6.4E-5	0.0	
Sr, <u>M</u>	1.3E-3	0.0	0.0	1.0E-3	0.0	
Y, <u>M</u>	6.6E-4	0.0	0.0	1.5E-6	9.9E-4	
Ru, <u>M</u>	1.9E-3	0.0	0.0	1.4E-3	9.7E-6	
Rh, <u>M</u>	5.2E-4	0.0	0.0	3.9E-4	0.0	
Pd, <u>M</u>	4.9E-4	0.0	0.0	3.4E-4	5.9E-5	
Ag, <u>M</u>	3.3E-5	0.0	0.0	2.5E-5	0.0	
Sn, <u>M</u>	2.2E-5	0.0	0.0	1.6E-5	0.0	
Sb, <u>M</u>	1.1E-5	0.0	0.0	8.2E-6	0.0	
Te, <u>M</u>	3.0E-4	0.0	0.0	2.2E-4	0.0	
Ba, <u>M</u>	1.0E-3	0.0	0.0	7.5E-4	0.0	
<b>Fission Product Rare Earths</b>						
La, <u>M</u>	9.1E-4	0.0	0.0	6.0E-8	1.36E-3	
Ce, <u>M</u>	2.2E-3	0.0	0.0	4.7E-8	3.3E-3	
Pr, <u>M</u>	8.4E-4	0.0	0.0	1.8E-8	1.26E-3	
Nd, <u>M</u>	2.5E-3	0.0	0.0	5.3E-8	3.8E-3	
Pm, <u>M</u>	2.6E-4	0.0	0.0	1.7E-8	3.9E-4	
Sm, <u>M</u>	3.5E-4	0.0	0.0	8.0E-8	5.2E-4	
Eu, <u>M</u>	4.4E-5	0.0	0.0	6.2E-8	6.6E-5	
Gd, <u>M</u>	1.1E-5	0.0	0.0	7.2E-7	1.51E-5	
<b>Actinides Including TRU</b>						
U, <u>M</u>	1.2E-4	0.0	0.0	<1.8E-9	1.8E-4	
Np, <u>M</u>	1.9E-4	0.0	0.0	<6.1E-9	2.8E-4	
Pu, <u>M</u>	1.5E-6	0.0	0.0	<4.8E-11	2.3E-6	
Am, <u>M</u>	1.5E-4	0.0	0.0	4.8E-9	2.27E-4	

<sup>a</sup>Concentration is reported as hydrogen ion in DW and DP.

<sup>b</sup>Concentration is reported as oxalate ion in DW and DP.

<sup>c</sup>Includes nitrate from HNO<sub>3</sub>.

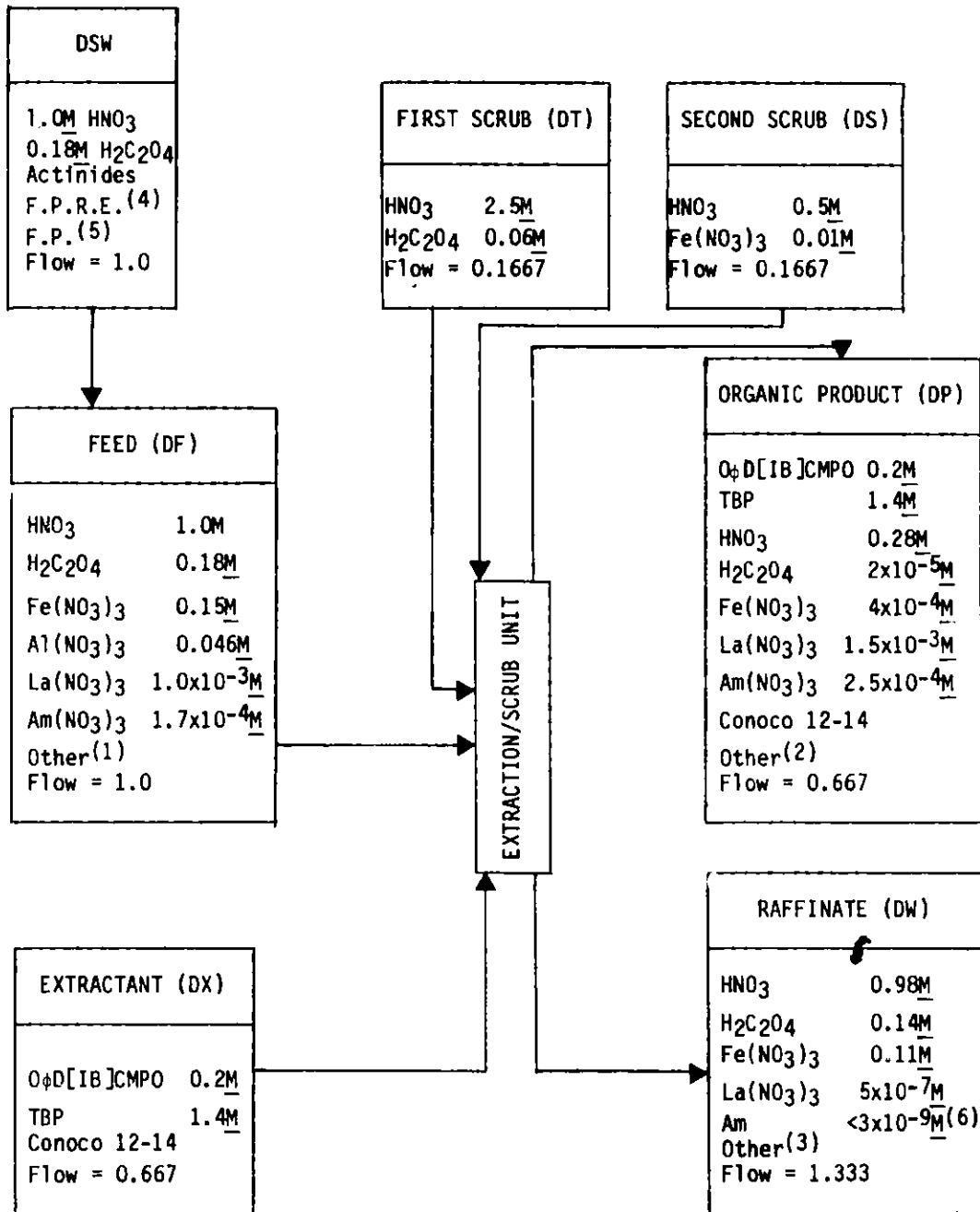

## NOTES

1. Other cations and anions from fuel, cladding, and fission products in DSW as listed in Table IV-7.
2. All other lanthanides, actinides, technetium, and yttrium, as listed in Table IV-7.
3. All metal ions not in organic effluent including almost all the non-rare earth fission products (see Table IV-7). Low americium concentration is based on having seven extraction stages.
4. Fission Product Rare Earths.
5. Fission Products
6. Equivalent to <100 nCi/g solidified raffinate as metal oxides.

Fig. IV-2. CMPO-TRUEX Process Flowsheet for Extraction of TRU Elements from DSW Solution

### (1) TRU Decontamination

The process flowsheet, in Fig. IV-2 and Table IV-7, will remove enough of the soluble TRU elements from the DSW feed to make its TRU concentration less than 100 nCi/g. The process requires seven extraction stages and six scrub stages. The small number of extraction stages is the result of a high extraction factor for the americium. The extraction factor could be made higher by increasing the O/A flow ratio, but, as shown in Table A-1 (Appendix A), a higher O/A ratio allows Pd into the organic product.

To achieve a TRU concentration below 1000 nCi/g in the DSW, six extraction stages and six scrub stages are sufficient.

### (2) Stripping of TRU Elements

Americium is fairly easy to strip from CMPO-TRUEX solvent. Compared with the CMP-TRUEX solvent, the CMPO-TRUEX solvent requires a lower  $\text{HNO}_3$  concentration in the aqueous feed to get comparable distribution coefficients. For CMPO-TRUEX solvent, typical stripping conditions are an O/A flow ratio ( $R_{st}$ ) of 2, 0.02M  $\text{HNO}_3$ , and a 0.01M HAN concentration to maintain reducing conditions in the scrub. The distribution coefficient for americium under these stripping conditions is 0.02. To effectively strip the americium from the organic phase, the stripping unit is designed to provide a decontamination factor which is ten times greater than that for the corresponding extraction section. (This contamination factor for stripping can actually be slightly lower as noted in Section IV.A.1.c above.) Thus, when it is desired to have an Am concentration in the aqueous raffinate below  $5 \times 10^{-8}\text{M}$  (below 1000 nCi of TRU per gram of solid raffinate as metal oxide), the Am concentration in the organic feed to the extraction/scrub unit should be  $5 \times 10^{-9}\text{M}$ . Calculations using Eq. A-2 (Appendix A) indicate that five strip stages are required to achieve this Am concentration in the organic feed for the extraction/scrub unit. Six stages are required if the Am concentration in the aqueous raffinate is to be below  $5 \times 10^{-9}\text{M}$  (below 100 nCi of TRU per gram of solid raffinate as metal oxide). Since the organic feed to the strip contactor contains some  $\text{HNO}_3$  from the extraction/scrub contactor, the acid level in the first stages of the stripping unit will be higher. This higher acid level will increase the distribution coefficient for Am and it may be necessary to increase the number of stripping stages by one or two.

## 3. CAW

### a. Introduction

In this section, flowsheets are presented for the removal of TRU elements from CAW solution by using CMP- and CMPO-TRUEX solvents. For each flowsheet, a six-stage scrub section is assumed. If two scrub sections (split scrub) are used, each scrub section has three stages. With six scrub stages and five or more extraction stages, the elements in Regimes II and IV (defined in Appendix A) are concentrated predominantly (90% to 95%) in the organic and aqueous effluents, respectively. Oxalic acid is added to the CAW.

Table IV-7. CMPO-TRUOX Process Flowsheet for Removal of TRU Elements from DSW Solution

	DF	DT	DS	DX	DW	DP	Notes
Phase	Aqueous	Aqueous	Aqueous	Organic	Aqueous	Organic	
Rel. Vol. Flow	1.0	0.1667	0.1667	0.667	1.333	0.667	
<b>Acids</b>							
HNO <sub>3</sub> , <u>M</u>	1.0	2.5	0.5	0.0	0.985	0.28	a
H <sub>2</sub> C <sub>2</sub> O <sub>4</sub> , <u>M</u>	0.18	0.06	0.0	0.0	0.143	2.1E-5	b
<b>Non-Fission Product Cations</b>							
Fe, <u>M</u>	0.15	0.0	0.01	0.0	0.114	4.0E-4	
Cr, <u>M</u>	0.0135	0.0	0.0	0.0	0.010	<2.6E-6	
Ni, <u>M</u>	0.008	0.0	0.0	0.0	0.006	<1.5E-6	
Al, <u>M</u>	0.046	0.0	0.0	0.0	0.034	<8.9E-6	
Na, <u>M</u>	0.15	0.0	0.0	0.0	0.112	<2.9E-5	
Ca, <u>M</u>	0.00135	0.0	0.0	0.0	0.001	<2.6E-7	
Cu, <u>M</u>	1.75E-3	0.0	0.0	0.0	1.31E-3	<3.3E-7	
Mg, <u>M</u>	1.6E-3	0.0	0.0	0.0	1.2E-3	0.0	
Mn, <u>M</u>	4.5E-3	0.0	0.0	0.0	3.4E-3	<8.7E-7	
Tl, <u>M</u>	2.0E-5	0.0	0.0	0.0	1.5E-5	0.0	
<b>Anions</b>							
NO <sub>3</sub> <sup>-</sup> , <u>M</u>	1.912	2.5	0.5	0.0	1.602	0.37	c
F <sup>-</sup> , <u>M</u>	0.008	0.0	0.0	0.0	0.006	0.0	
SO <sub>4</sub> <sup>2-</sup> , <u>M</u>	0.012	0.0	0.0	0.0	0.009	0.0	
<b>Fission Products</b>							
Zr, <u>M</u>	5.6E-3	0.0	0.0	0.0	4.2E-3	<6.2E-9	
Cd, <u>M</u>	5.0E-5	0.0	0.0	0.0	3.8E-5	0.0	
Nb, <u>M</u>	1.4E-5	0.0	0.0	0.0	1.05E-5	0.0	
Mo, <u>M</u>	1.8E-4	0.0	0.0	0.0	1.34E-4	2.2E-6	
Se, <u>M</u>	9.5E-5	0.0	0.0	0.0	7.1E-5	0.0	
Sr, <u>M</u>	1.4E-3	0.0	0.0	0.0	1.05E-3	<2.7E-7	
Y, <u>M</u>	7.3E-4	0.0	0.0	0.0	6.6E-6	1.08E-3	
Ru, <u>M</u>	2.1E-3	0.0	0.0	0.0	1.38E-3	3.9E-4	
Rh, <u>M</u>	5.7E-4	0.0	0.0	0.0	4.3E-4	0.0	
Pd, <u>M</u>	5.4E-4	0.0	0.0	0.0	3.8E-4	5.0E-5	
Ag, <u>M</u>	3.6E-5	0.0	0.0	0.0	2.7E-5	0.0	
Sn, <u>M</u>	2.4E-5	0.0	0.0	0.0	1.8E-5	0.0	
Sb, <u>M</u>	1.2E-5	0.0	0.0	0.0	9.0E-6	0.0	
Te, <u>M</u>	3.3E-4	0.0	0.0	0.0	2.5E-4	0.0	
Ba, <u>M</u>	1.1E-3	0.0	0.0	0.0	8.2E-4	<2.1E-7	
<b>Fission Product Rare Earths</b>							
La, <u>M</u>	1.0E-3	0.0	0.0	0.0	4.9E-7	1.5E-3	
Ce, <u>M</u>	2.4E-3	0.0	0.0	0.0	<1.2E-6	3.6E-3	
Pr, <u>M</u>	9.2E-4	0.0	0.0	0.0	<4.5E-7	1.4E-3	
Nd, <u>M</u>	2.7E-3	0.0	0.0	0.0	<1.3E-6	4.0E-3	
Pm, <u>M</u>	2.9E-4	0.0	0.0	0.0	<1.4E-7	4.4E-4	
Sm, <u>M</u>	3.9E-4	0.0	0.0	0.0	<1.9E-7	5.8E-4	
Eu, <u>M</u>	4.8E-5	0.0	0.0	0.0	<2.3E-8	7.1E-5	
Gd, <u>M</u>	1.2E-5	0.0	0.0	0.0	<5.9E-9	1.8E-5	
<b>Actinides Including TRU</b>							
U, <u>M</u>	1.3E-4	0.0	0.0	0.0	<1.9E-9	1.95E-4	
Np, <u>M</u>	2.1E-4	0.0	0.0	0.0	<3.1E-9	3.15E-4	
Pu, <u>M</u>	1.7E-6	0.0	0.0	0.0	<2.5E-11	2.5E-6	
Am, <u>M</u>	1.7E-4	0.0	0.0	0.0	2.5E-9	2.5E-4	

<sup>a</sup>Concentration is reported as hydrogen ion in DW and DP.

<sup>b</sup>Concentration is reported as oxalate ion in DW and DP.

<sup>c</sup>Includes nitrate from HNO<sub>3</sub> acid.

b. DHDECMP Extractant

Table IV-5 lists the distribution coefficient data used to derive the CMP-TRUEX flowsheet for use with CAW solution (Fig. IV-3).

(1) TRU Decontamination

The process flowsheet, Fig. IV-3 and Table IV-8, will remove enough of the soluble TRU elements from the CAW feed to make its TRU concentration less than 100 nCi/g. The process requires 14 extraction stages and six scrub stages. The large number of extraction stages is required because of the low extraction factor for the americium. The extraction factor could be made higher by increasing the O/A flow ratio; but, as shown in Table A-1 of Appendix A, a higher O/A ratio drives Pd into the organic product and results in a large buildup of Tc at the feed stage (several orders of magnitude above its feed composition). At this level,  $\text{HTcO}_4$  could tie up most of the extractant and ruin the process chemistry. With the specified O/A ratio, Tc exits in the aqueous raffinate and reaches a concentration in the feed stage which is only three times higher than its concentration in the aqueous feed.

To achieve a TRU concentration below 1000 nCi/g in the CAW solution, 11 extraction stages and six scrub stages are sufficient.

(2) Stripping of TRU Elements

The discussion given in Section IV.A.2.b.(2) applies here also.

c. O $\phi$ D[IB]CMPO Extractant

The distribution coefficients listed in Table IV-4 were used to derive the CMPO-TRUEX process flowsheet for use with CAW solution (Fig. IV-4).

(1) TRU Decontamination

The process flowsheet, Fig. IV-4 and Table IV-9, will remove enough of the soluble TRU elements from the CAW feed to make its TRU concentration less than 100 nCi/g. The process requires six extraction stages and six scrub stages. The small number of extraction stages is the result of a high extraction factor for the americium. The extraction factor could be made higher by increasing the O/A flow ratio; but, as shown in Table A-1 in Appendix A, a higher O/A ratio drives Pd into the organic product. Table A-1 also shows that, at the higher O/A ratio, the Tc in the CAW will exit mainly with the organic stream in the extraction/scrub unit.

To achieve a TRU concentration less than 1000 nCi/g in the CAW solution, five extraction stages and six scrub stages are sufficient.

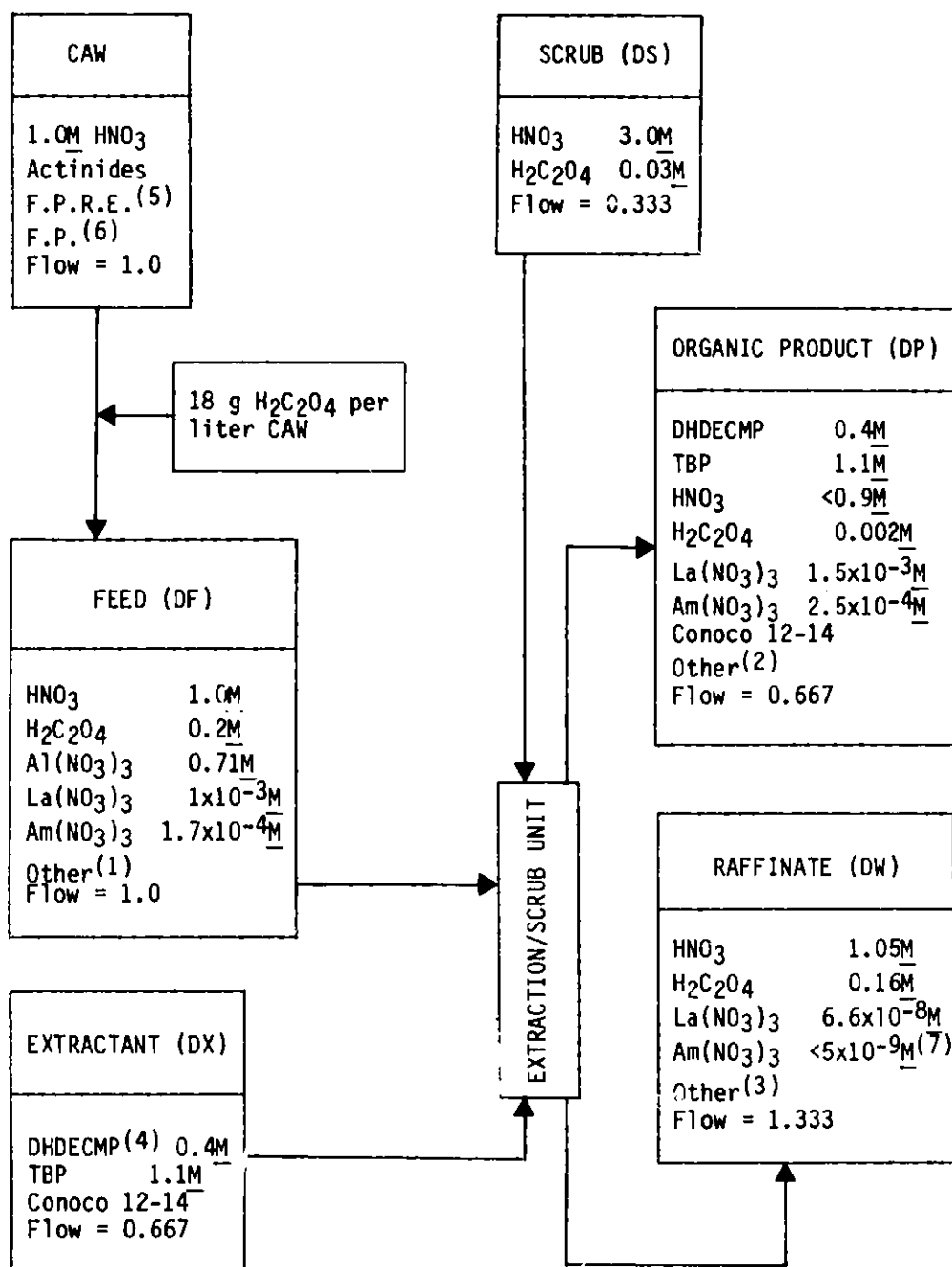

## Notes

1. Other cations and anions from fuel, cladding, and fission products in CAW as listed in Table IV-8.
2. All other lanthanides, actinides, and yttrium as listed in Table IV-8.
3. All metal ions not in organic effluent including almost all the non-rare earth fission products (see Table IV-8). Low americium concentration is based on having 14 extraction stages.
4. Added as the ~86% material.
5. Fission Product Rare Earths.
6. Fission Products.
7. Equivalent to <100 nCi/g solidified raffinate as metal oxides.

Fig. IV-3. CMP-TRU Process Flowsheet for Extraction of TRU Elements from CAW Solution

Table IV-8. CMP-TRUEX Process Flowsheet for the  
Removal of TRU Elements from CAW Solution

	DF	DS	DX	DW	DP	Notes
Phase	Aqueous	Aqueous	Organic	Aqueous	Organic	
Rel. Vol. Flow	1.0	0.333	0.667	1.333	0.667	
<b>Acids</b>						
HNO <sub>3</sub> , <u>M</u>	1.0	3.0	0.0	1.05	0.9	a
H <sub>2</sub> C <sub>2</sub> O <sub>4</sub> , <u>M</u>	0.2	0.03	0.0	0.157	0.0018	b
<b>Non-Fission Product Cations</b>						
Fe, <u>M</u>	0.13	0.0	0.0	0.10	0.0	
Cr, <u>M</u>	0.013	0.0	0.0	0.010	0.0	
Ni, <u>M</u>	0.0069	0.0	0.0	0.005	0.0	
Al, <u>M</u>	0.71	0.0	0.0	0.53	0.0	
Be, <u>M</u>	0.0013	0.0	0.0	0.001	0.0	
Na, <u>M</u>	0.18	0.0	0.0	0.135	0.0	
Ca, <u>M</u>	0.001	0.0	0.0	0.0008	0.0	
Cu, <u>M</u>	1.4E-3	0.0	0.0	1.05E-3	0.0	
Mg, <u>M</u>	1.3E-3	0.0	0.0	9.8E-4	0.0	
Mn, <u>M</u>	1.4E-3	0.0	0.0	1.05E-3	0.0	
Si, <u>M</u>	9.2E-3	0.0	0.0	6.9E-3	0.0	
Ti, <u>M</u>	2.0E-5	0.0	0.0	1.5E-5	0.0	
<b>Anions</b>						
NO <sub>3</sub> <sup>-</sup> , <u>M</u>	3.00	3.0	0.0	2.55	0.962	c
F <sup>-</sup> , <u>M</u>	0.15	0.0	0.0	0.11	0.0	
SO <sub>4</sub> <sup>2-</sup> , <u>M</u>	0.27	0.0	0.0	0.20	0.0	
PO <sub>4</sub> <sup>3-</sup> , <u>M</u>	0.0013	0.0	0.0	0.0010	0.0	
<b>Fission Products</b>						
Zr, <u>M</u>	5.6E-3	0.0	0.0	4.2E-3	0.0	
Cd, <u>M</u>	5.0E-5	0.0	0.0	3.8E-5	0.0	
Nb, <u>M</u>	9.4E-5	0.0	0.0	7.0E-5	0.0	
Mo, <u>M</u>	1.8E-4	0.0	0.0	1.35E-4	0.0	
Se, <u>M</u>	9.5E-5	0.0	0.0	7.1E-5	0.0	
Rb, <u>M</u>	5.2E-4	0.0	0.0	3.9E-4	0.0	
Sr, <u>M</u>	1.4E-3	0.0	0.0	1.05E-3	0.0	
Y, <u>M</u>	7.3E-4	0.0	0.0	1.7E-6	1.10E-3	
Ru, <u>M</u>	2.1E-3	0.0	0.0	1.6E-3	1.07E-5	
Rh, <u>M</u>	5.7E-4	0.0	0.0	4.3E-4	0.0	
Pd, <u>M</u>	5.4E-4	0.0	0.0	3.7E-4	6.5E-5	
Ag, <u>M</u>	3.6E-5	0.0	0.0	2.7E-5	0.0	

(Contd,



Table IV-8. (Contd)

	DF	DS	DX	DW	DP	Notes
Sn, <u>M</u>	2.4E-5	0.0	0.0	1.8E-5	0.0	
Sb, <u>M</u>	1.2E-5	0.0	0.0	9.0E-6	0.0	
Te, <u>M</u>	3.3E-4	0.0	0.0	2.5E-4	0.0	
Cs, <u>M</u>	2.3E-3	0.0	0.0	1.72E-3	0.0	
Ba, <u>M</u>	1.1E-3	0.0	0.0	8.2E-4	0.0	
Tc, <u>M</u>	9.8E-4	0.0	0.0	7.4E-4	7.5E-7	
Fission Product Rare Earths						
La, <u>M</u>	1.0E-3	0.0	0.0	6.6E-8	1.5E-3	
Ce, <u>M</u>	2.4E-3	0.0	0.0	5.1E-8	3.6E-3	
Pr, <u>M</u>	9.2E-4	0.0	0.0	2.0E-8	1.38E-3	
Nd, <u>M</u>	2.7E-3	0.0	0.0	5.7E-8	4.0E-3	
Pm, <u>M</u>	2.9E-4	0.0	0.0	1.9E-8	4.4E-4	
Sm, <u>M</u>	3.9E-4	0.0	0.0	8.9E-8	5.8E-4	
Eu, <u>M</u>	4.8E-5	0.0	0.0	6.8E-8	7.2E-5	
Gd, <u>M</u>	1.2E-5	0.0	0.0	7.8E-7	1.64E-5	
Actinides Including TRU						
U, <u>M</u>	1.3E-4	0.0	0.0	<4.2E-9	2.0E-4	
Np, <u>M</u>	2.1E-4	0.0	0.0	<6.7E-9	3.2E-4	
Pu, <u>M</u>	1.7E-6	0.0	0.0	<5.3E-11	2.5E-6	
Am, <u>M</u>	1.7E-4	0.0	0.0	5.3E-9	2.5E-4	

<sup>a</sup>Concentration is reported as hydrogen ion in DW and DP.

<sup>b</sup>Concentration is reported as oxalate ion in DW and DP.

<sup>c</sup>Includes nitrate from  $\text{HNO}_3$ .

## (2) Stripping of TRU Elements

The discussion given in Section IV.A.2.c.(2) applies here also.

## B. Experimental Verification of Reference Flowsheets

Two countercurrent experiments were designed and carried out to verify the reference flowsheet for TRU decontamination of DSW by the CMPO-TRUEX process. The first countercurrent experiment was run in the absence of TRU elements and Tc in a ten-stage apparatus that allowed establishment of the behavior of fission and corrosion product species and chemical reagent species (e.g., Fe and Al) present in DSW. After this experiment had been continued long enough to assure that most species in the apparatus had reached a near steady-state condition, samples of both phases were removed from each stage, and the remaining volumes were left in the apparatus for initiating the

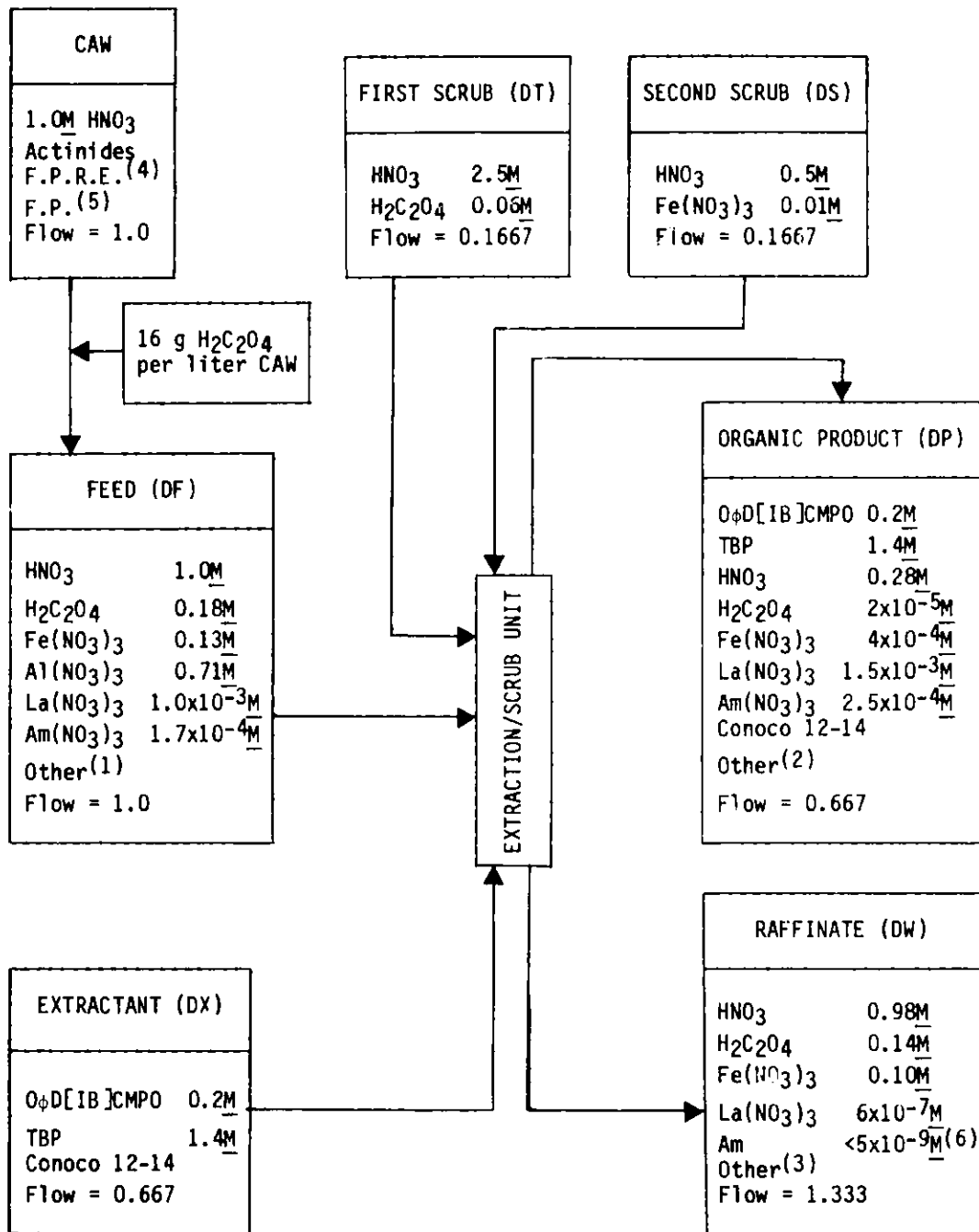

## NOTES

1. Other cations and anions from fuel, cladding, and fission products in CAW as listed in Table IV-9.
2. All other lanthanides, actinides, technetium, and yttrium, as listed in Table IV-9.
3. All metal ions not in organic effluent including almost all the non-rare earth fission products (see Table IV-9). Low americium concentration is based on having six extraction stages.
4. Fission Product Rare Earths.
5. Fission Products.
6. Equivalent to <100 nCi/g solidified raffinate as metal oxides.

Fig. IV-4. CMPO-TRUOX Process Flowsheet for Extraction of TRU Elements from CAW Solution

Table IV-9. CMPO-TRUEx Process Flowsheet for Removal of TRU Elements from CAW Solution

	DF	DT	DS	DX	DW	DP	Notes
Phase	Aqueous	Aqueous	Aqueous	Organic	Aqueous	Organic	
Rel. Vol. Flow	1.0	0.1667	0.1667	0.667	1.333	0.667	
<b>Acids</b>							
HNO <sub>3</sub> , <u>M</u>	1.0	2.5	0.5	0.0	0.985	0.28	a
H <sub>2</sub> C <sub>2</sub> O <sub>4</sub> , <u>M</u>	0.18	0.06	0.0	0.0	0.143	2.1E-5	b
<b>Non-Fission Product Cations</b>							
Fe, <u>M</u>	0.13	0.0	0.01	0.0	0.099	4.0E-4	
Cr, <u>M</u>	0.013	0.0	0.0	0.0	0.010	<2.5E-6	
Ni, <u>M</u>	0.0069	0.0	0.0	0.0	0.005	<1.3E-6	
Al, <u>M</u>	0.71	0.0	0.0	0.0	0.53	<1.4E-4	
Be, <u>M</u>	0.0013	0.0	0.0	0.0	0.0010	0.0	
Na, <u>M</u>	0.18	0.0	0.0	0.0	0.135	<3.5E-5	
Ca, <u>M</u>	0.001	0.0	0.0	0.0	0.0008	<1.9E-7	
Cu, <u>M</u>	1.4E-3	0.0	0.0	0.0	1.05E-3	<2.7E-7	
Mg, <u>M</u>	1.3E-3	0.0	0.0	0.0	1.0E-3	0.0	
Mn, <u>M</u>	1.4E-3	0.0	0.0	0.0	1.05E-3	<2.7E-7	
Si, <u>M</u>	9.2E-3	0.0	0.0	0.0	6.9E-3	0.0	
Ti, <u>M</u>	2.0E-5	0.0	0.0	0.0	1.5E-5	0.0	
<b>Anions</b>							
NO <sub>3</sub> <sup>-</sup> , <u>M</u>	3.00	2.5	0.5	0.0	2.44	0.37	c
F <sup>-</sup> , <u>M</u>	0.15	0.0	0.0	0.0	0.11	0.0	
SO <sub>4</sub> <sup>2-</sup> , <u>M</u>	0.27	0.0	0.0	0.0	0.20	0.0	
PO <sub>4</sub> <sup>3-</sup> , <u>M</u>	0.0013	0.0	0.0	0.0	0.0010	0.0	
<b>Fission Products</b>							
Zr, <u>M</u>	5.6E-3	0.0	0.0	0.0	4.2E-3	<6.2E-9	
Cd, <u>M</u>	5.0E-5	0.0	0.0	0.0	3.8E-5	0.0	
Nb, <u>M</u>	9.4E-5	0.0	0.0	0.0	7.0E-5	0.0	
Mo, <u>M</u>	1.8E-4	0.0	0.0	0.0	1.34E-4	2.6E-6	
Se, <u>M</u>	9.5E-5	0.0	0.0	0.0	7.1E-5	0.0	
Rb, <u>M</u>	5.2E-4	0.0	0.0	0.0	3.9E-4	0.0	
Sr, <u>M</u>	1.4E-3	0.0	0.0	0.0	1.05E-3	<2.7E-7	
Y, <u>M</u>	7.3E-4	0.0	0.0	0.0	5.3E-6	1.08E-3	
Ru, <u>M</u>	2.1E-3	0.0	0.0	0.0	1.34E-3	4.6E-4	
Rh, <u>M</u>	5.7E-4	0.0	0.0	0.0	4.3E-4	0.0	
Pd, <u>M</u>	5.4E-4	0.0	0.0	0.0	3.7E-4	6.4E-5	
Ag, <u>M</u>	3.6E-5	0.0	0.0	0.0	2.7E-5	0.0	
Sn, <u>M</u>	2.4E-5	0.0	0.0	0.0	1.8E-5	0.0	

(Contd)

Table IV-9. (Contd)

	DF	DT	DS	DX	DW	DP	Notes
Sb, <u>M</u>	1.2E-5	0.0	0.0	0.0	9.0E-6	0.0	
Te, <u>M</u>	3.3E-4	0.0	0.0	0.0	2.5E-4	0.0	
Cs, <u>M</u>	2.3E-3	0.0	0.0	0.0	1.7E-3	0.0	
Ba, <u>M</u>	1.1E-3	0.0	0.0	0.0	8.2E-4	<2.1E-7	
Tc, <u>M</u>	9.8E-4	0.0	0.0	0.0	2.3E-5	1.42E-3	
Fission Product Rare Earths							
La, <u>M</u>	1.0E-3	0.0	0.0	0.0	5.6E-7	1.5E-3	
Ce, <u>M</u>	2.4E-3	0.0	0.0	0.0	<1.3E-6	3.6E-3	
Pr, <u>M</u>	9.2E-4	0.0	0.0	0.0	<5.1E-7	1.4E-3	
Nd, <u>M</u>	2.7E-3	0.0	0.0	0.0	<1.5E-6	4.0E-3	
Pm, <u>M</u>	2.9E-4	0.0	0.0	0.0	<1.6E-7	4.4E-4	
Sm, <u>M</u>	3.9E-4	0.0	0.0	0.0	<2.2E-7	5.8E-4	
Eu, <u>M</u>	4.8E-5	0.0	0.0	0.0	<2.7E-8	7.2E-5	
Gd, <u>M</u>	1.2E-5	0.0	0.0	0.0	<6.7E-9	1.8E-5	
Actinides Including TRU							
U, <u>M</u>	1.3E-4	0.0	0.0	0.0	<4.2E-9	1.95E-4	
Np, <u>M</u>	2.1E-4	0.0	0.0	0.0	<6.7E-9	3.15E-4	
Pu, <u>M</u>	1.7E-6	0.0	0.0	0.0	<5.3E-11	2.5E-6	
Am, <u>M</u>	1.7E-4	0.0	0.0	0.0	5.3E-9	2.5E-4	

<sup>a</sup>Concentration is reported as hydrogen ion in DW and DP.

<sup>b</sup>Concentration is reported as oxalate ion in DW and DP.

<sup>c</sup>Includes nitrate from HNO<sub>3</sub>.

second experiment. Subsequently, the inactive feed solution was replaced by one of the same composition except for the addition of Am, Pu, Np, and Tc. The volume of the feed additions, however, was decreased to that commensurate with the lower phase volumes in each stage. The experiment was continued until the calculated requisite number of raffinate samples were collected; at this point, the TRU concentrations in the raffinate samples were within >90% of their steady-state concentrations. Experimental details of these experiments are given in Appendix B.

### 1. Extraction and Scrub Behavior of DSW Components

#### a. TRU Elements and Uranium

Figures IV-5 to IV-7 show the aqueous and organic phase concentrations of Am, Np, and Pu in each stage of the countercurrent experiment at their near-steady-state condition. Figure IV-5 also shows americium data for the final batch extraction stage (stage 0). Data for batch scrubbing stages 11-13 are shown for Am and Np in Figs. IV-5 and IV-6. The plutonium concentration was below its detectability in the aqueous phases in stages 1-3.

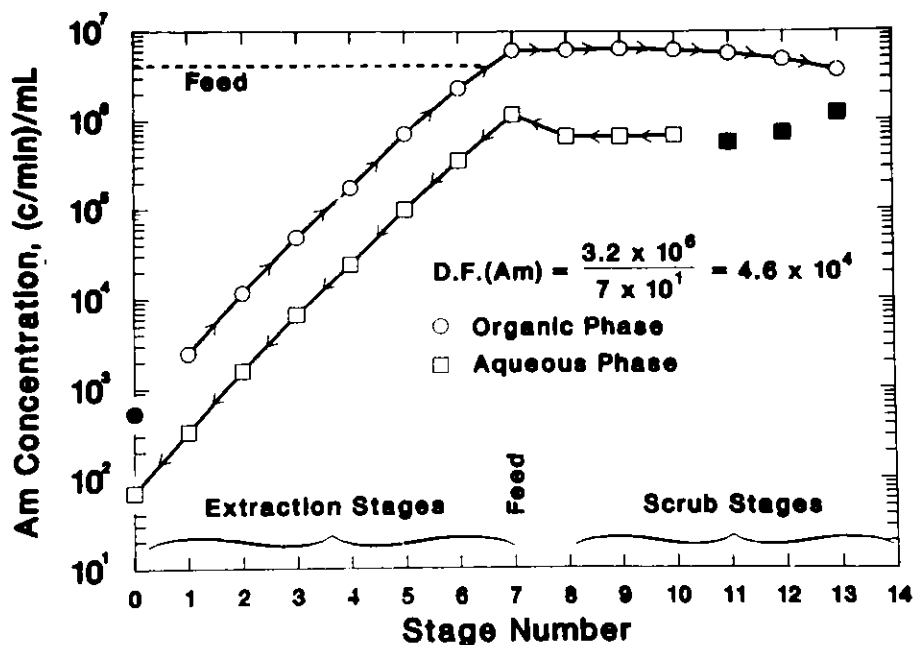

Fig. IV-5. The Americium Concentration in the Organic and Aqueous Phases of Each Stage of the Countercurrent Experiment at Near-Steady-State. (Darkened symbols, not connected by line, were batch contacts.)

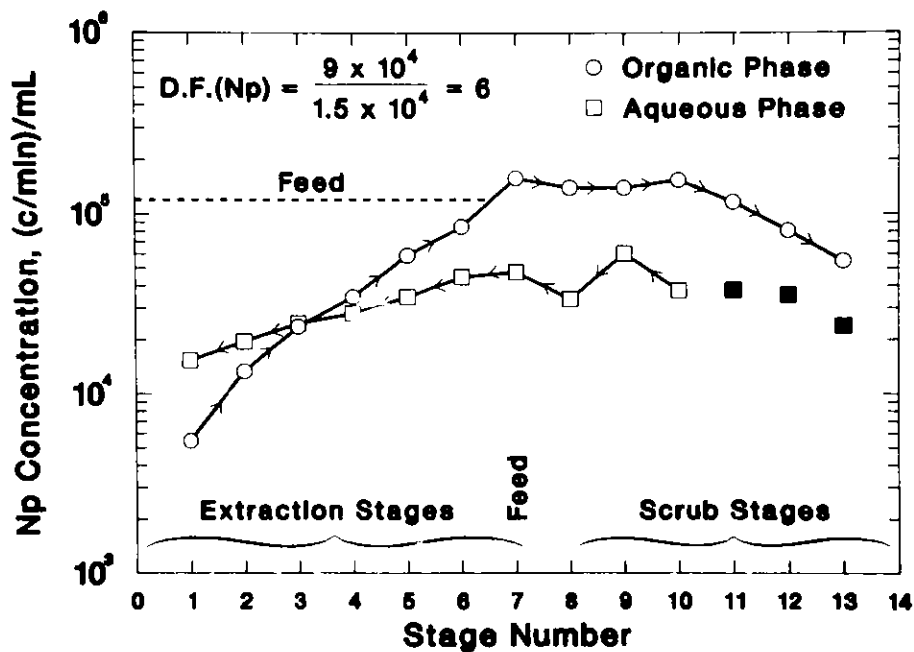

Fig. IV-6. The Neptunium Concentration in the Organic and Aqueous Phases of Each Stage of the Countercurrent Experiment at Near-Steady-State. (Darkened symbols, not connected by lines, were batch contacts.)

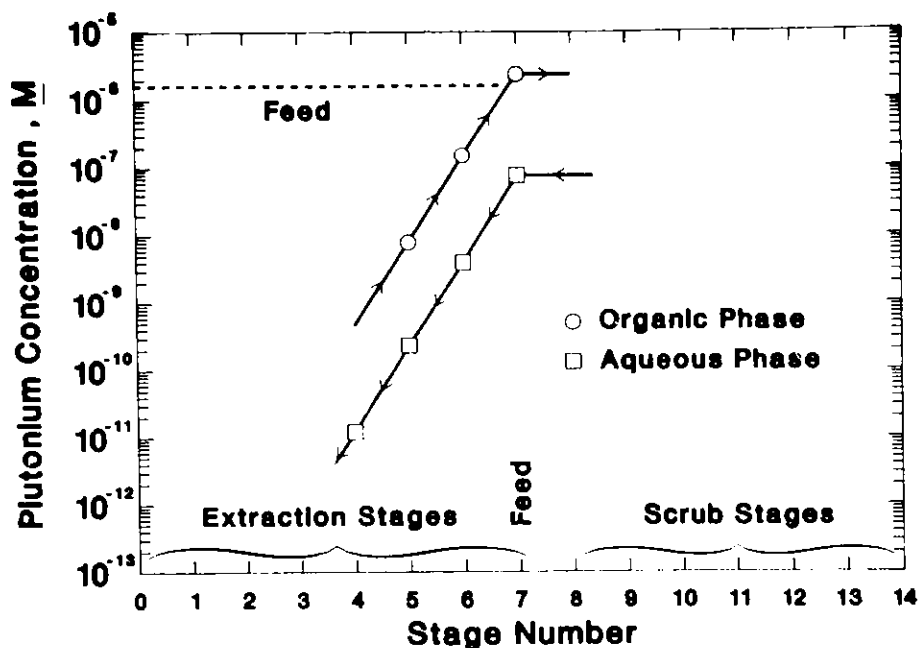

Fig. IV 7. The Plutonium Concentration in the Organic and Aqueous Phases of Each Stage of the Countercurrent Experiment at Near-Steady-State

Table IV-10 contains the distribution ratio data for the TRU elements and uranium. The solvent extraction behavior of both americium and plutonium was consistent with what was expected from earlier batch experiments. Both elements demonstrated well-behaved extraction characteristics from stage to stage and attained distribution ratios that were high enough to easily achieve requisite concentration levels in the raffinate. The influence of loading on  $D_{Am}$  in the extraction section makes predictions of extraction parameters both simple and trustworthy. The  $D_{Pu}$  value reflects the presence of both Pu(III) and Pu(IV) [HORWITZ-1983].

The behavior of neptunium (Fig. IV-6 and Table IV-10) was disappointing. Although neptunium was added to the synthetic DSW as Np(V) and  $\text{NaNO}_2$  was added to further stabilize the Np(V), the high concentration of oxalic acid was expected to shift the disproportionation of Np(V) to Np(IV) and Np(VI). Since Np(VI) is reduced rapidly to Np(V) by oxalic acid, Np(V) should transform to Np(IV) in DSW. Because the majority (86%) of the neptunium was extracted, the disproportionation did proceed as described above (but not to the extent that was expected).

A mini-countercurrent experiment was performed to determine whether increasing the concentration of neptunium by two orders of magnitude would increase the transformation of Np(V) to Np(IV). The rationale for this hypothesis was that the rate of disproportionation of Np(V) would increase at the higher concentration. This experiment was set up with only three stages, the feed stage being the middle stage. The relative volumes of feed, scrub, and organic were those found in Table B-6 in Appendix B.

Table IV-10. Distribution Ratios of Actinide Elements in Each Stage of the Countercurrent Experiment

Stage <sup>a</sup>	Distribution Ratio			
	U <sup>b</sup>	Np	Pu <sup>b</sup>	Am
0	NA <sup>c</sup>	NA	NA	7.6
1	NA	0.36	NA	7.5
2	NA	0.68	NA	7.4
3	NA	0.96	NA	7.3
4	NA	1.2	NA	7.2
5	NA	1.7	34	7.1
6	<10 <sup>2</sup>	1.9	39	6.5
7	2.6 x 10 <sup>2</sup>	3.3	32	5.2
8	5.1 x 10 <sup>2</sup>	4.2	NA	9.4
9	6.1 x 10 <sup>2</sup>	2.3	NA	9.7
10	6.5 x 10 <sup>2</sup>	4.1	NA	9.1
11	6.5 x 10 <sup>2</sup>	3.1	NA	10.0
12	NA	2.3	NA	6.7
13	NA	2.3	NA	3.0

<sup>a</sup>Stage 7 is the feed stage; stages 0-7 are extraction stages; stages 8 and 9 are scrub one stages; and stages 10-13 are scrub two stages.

<sup>b</sup>Organic phase concentrations were not measured; distribution ratios were estimated by material balance.

<sup>c</sup>NA means not analyzed.

Compiled in Table IV-11 are the raffinate neptunium concentration data for this experiment. Because the concentration of Np does not appear to vary with each feed addition step (i.e., raffinate sample number), these data indicate that near to steady-state conditions were reached. The distribution ratios in Table IV-12 show some improvement in  $D_{Np}$  for the scrub and feed stages, but  $D_{Np}$  was lower in the extraction stage.

Table IV-11. Raffinate Concentrations of Np for the Mini-Countercurrent Experiment

Raffinate <sup>a</sup> Sample No.	$[Np]_{Raf}/[Np]_{Feed}^b$
1	0.27
2	0.18
3	0.21
4	0.22

<sup>a</sup>After all stages of the apparatus are operational, a raffinate sample exits the countercurrent extraction system each time a fresh feed solution is added.

<sup>b</sup>The ratio of [Np] in each raffinate sample to that of [Np] in the feed.

Figures IV-8 and IV-9 show the approach of americium and neptunium to steady state in the batch countercurrent experiment. The line in each figure was calculated using the experimental distribution ratios presented in Table IV-10 and the spread sheet calculation discussed in Appendix A. These calculations assumed a 3% increase in the relative volume of the organic phase to that of the aqueous phase.

Table IV-12. Distribution Ratio of Neptunium ( $D_{Np}$ ) in Each Stage of the Mini-Counter-current Experiment

Stage	$D_{Np}$
Scrub	10.2
Feed	4.6
Extraction	0.56

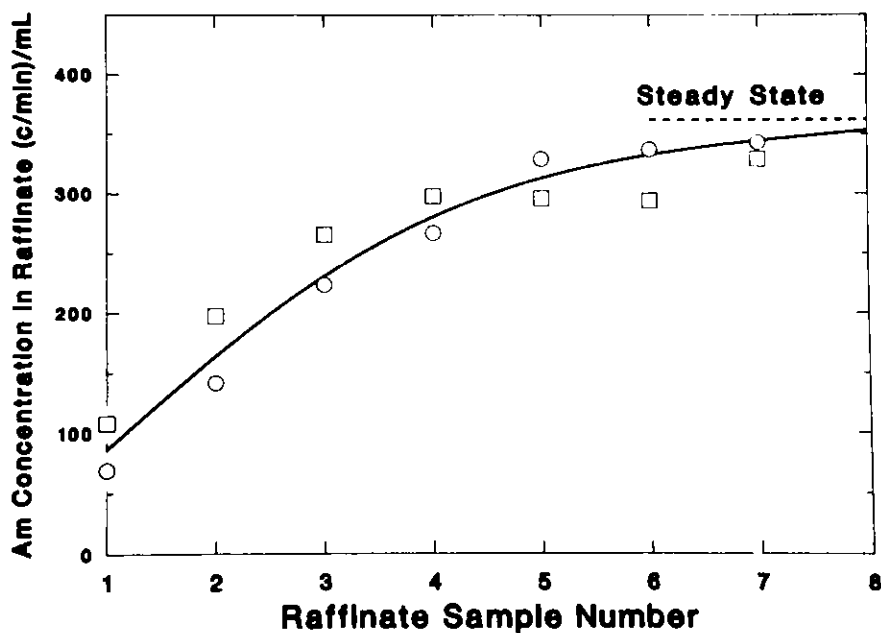

Fig. IV-8. The Americium Concentration in a Raffinate Sample vs. the Raffinate Sample Number. The data points are raffinate samples of the double-diamond countercurrent experiment discussed in Appendix B (the two sets of raffinate samples are differentiated by the symbol type); the line is calculated based on the near-steady-state distribution ratios measured for each stage of the experiment.



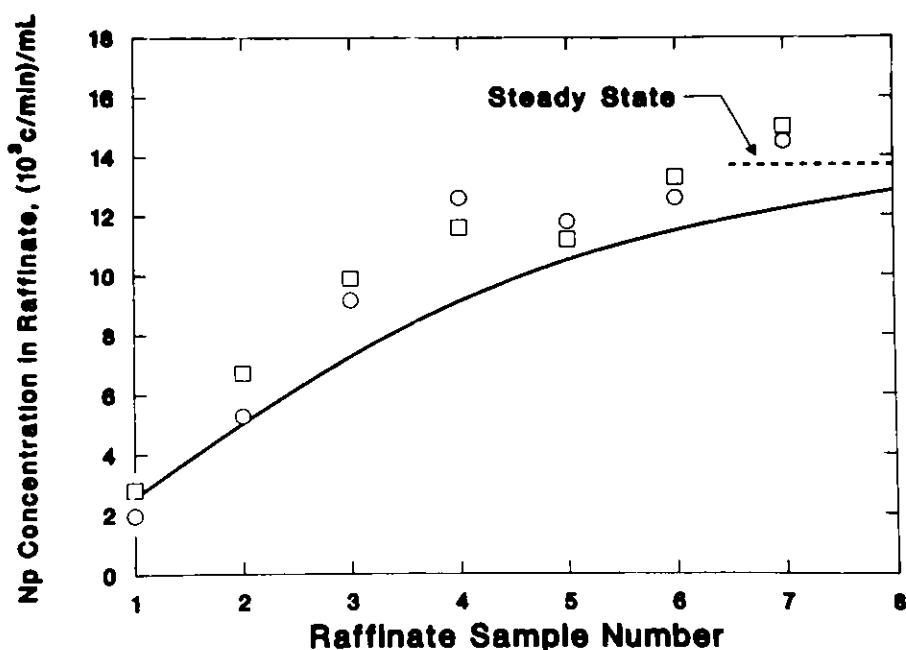

Fig. IV-9. The Neptunium Concentration in a Raffinate Sample vs. the Raffinate Sample Number. The data points are raffinate samples of the double-diamond counter-current experiment (the two sets of raffinate are differentiated by the symbol type); the line is calculated based on the near-steady-state distribution ratios measured for each stage.

The good fit between the curve derived from distribution-ratio measurements and the raffinate data indicates a consistency in the experiment that makes an extrapolation to a steady-state condition valid. The steady-state decontamination factors for the TRU elements in this experiment are presented in Table IV-13.

Table IV-13. Steady-State Decontamination Factors of TRU Elements and Uranium from Simulated DSW

Element	Number of Extraction Stages to Measured D.F.	Measured D.F.	D.F. Calculated or Measured after Seven Extraction Stages
U	2	$1.3 \times 10^4$	$1.0 \times 10^{16}{}^a$
Np	7	6	6
Pu	4	$1.0 \times 10^5$	$5.0 \times 10^{14}{}^a$
Am	8	$4.6 \times 10^4$	$1.0 \times 10^4$

<sup>a</sup>Because stripping of solvent is never perfect, some residual concentration of these species will be in the recycled solvent; therefore, these values would not be achieved in actual practice.

b. Other DSW Components

Tables IV-14 and IV-15 contain the distribution ratios for the nonactinide species that were measured in each stage of the countercurrent experiment. Distribution ratios were close to what was predicted from batch distribution ratio measurements (shown in Fig. V-3). Data for ruthenium and palladium indicate the presence of at least two species with different distribution ratios.

Distribution ratios for technetium were measured by spiking the near steady-state solutions from the cold run with  $^{99}\text{TcO}_4^-$  and, after equilibration at  $40^\circ\text{C}$ , measuring radiometrically the concentration of  $^{99}\text{Tc}$  in each phase. The raffinate concentration of Tc was measured for each raffinate sample of the hot run, and a fit of these data to a calculated line based on the measured  $D_{\text{Tc}}$  values was attempted (Fig. IV-10). The calculated line, shown as the solid line far below the data points, is a poor fit to the data. The procedure of chemical separation and radiometric analysis was shown to be quantitative with its determination of the  $[^{99}\text{Tc}]$  in the feed, which was accurately known from a careful assay of its stock solution; therefore, the raffinate data are not in question.

The dashed line through the data points in Fig. IV-10 is an empirical attempt to fit the data. The assumptions made in arriving at this line were:

The distribution ratio was constant through the extraction section (stages 1-7).

The distribution ratio in the first scrub section (stages 8 and 9) was the product of (1) the distribution ratio in the extraction section and (2) the ratio of the distribution ratio of  $\text{TcO}_4^-$  at 1.5 and 1.1M  $\text{HNO}_3$  from Fig. V-2;  $[D_{\text{Tc}}(\text{Extraction}) \times 0.60]$ .

The distribution ratio in the second scrub section (stage 10) was the product of (1) the distribution ratio in the extraction section and (2) the ratio of the distribution ratio of  $\text{TcO}_4^-$  at 0.5 and 1.1M  $\text{HNO}_3$  from Fig. V-2;  $[D_{\text{Tc}}(\text{Extraction}) \times 1.9]$ .

The best-fit distribution ratio was 2.2 for the extraction section, not that far from the  $\sim 2.5$  value measured for most of the extraction section. This calculation predicts a steady-state raffinate  $\text{TcO}_4^-$  concentration of 7.9% of that in the undiluted feed, for a decontamination factor of 9.5. Based on the steady-state value derived from this fit, 89% of the technetium from the feed will be in the TRU product.

c. Disengagement Behavior

The phase separations for the countercurrent experiments were all very good. Within one minute the large volumes of phases (Table B-6, Appendix B) broke up to form two clear solutions; there was no visible sign of cloudiness due to entrainment of one phase in the other, or any change of these properties with throughput. No interfacial crud was observed in any of the stages throughout the two experiments.

Table IV-14. Distribution Ratios of Nonfission Products in Each Stage of the Countercurrent Experiment

Stage No. <sup>c</sup>	Distribution Ratio a,b								
	H <sub>2</sub> Ox <sup>d</sup>	Mg	Al	Ca	Cr	Mn	Fe	Ni	Cu
1	1.1 x 10 <sup>-1</sup>	<10 <sup>-2</sup>	<10 <sup>-2</sup>	<10 <sup>-2</sup>	<10 <sup>-3</sup>	1.1 x 10 <sup>-2</sup>	3.7 x 10 <sup>-2</sup>	<10 <sup>-2</sup>	<10 <sup>-2</sup>
2	1.0 x 10 <sup>-1</sup>	<10 <sup>-2</sup>	<10 <sup>-2</sup>	<10 <sup>-2</sup>	<10 <sup>-3</sup>	1.2 x 10 <sup>-2</sup>	4.2 x 10 <sup>-2</sup>	<10 <sup>-2</sup>	<10 <sup>-2</sup>
3	NA <sup>e</sup>	<10 <sup>-2</sup>	<10 <sup>-2</sup>	<10 <sup>-2</sup>	<10 <sup>-3</sup>	1.2 x 10 <sup>-2</sup>	4.4 x 10 <sup>-2</sup>	<10 <sup>-2</sup>	<10 <sup>-2</sup>
4	NA	<10 <sup>-2</sup>	<10 <sup>-2</sup>	<10 <sup>-2</sup>	<10 <sup>-3</sup>	1.2 x 10 <sup>-2</sup>	4.3 x 10 <sup>-2</sup>	<10 <sup>-2</sup>	<10 <sup>-2</sup>
5	1.1 x 10 <sup>-1</sup>	<10 <sup>-2</sup>	<10 <sup>-2</sup>	<10 <sup>-2</sup>	<10 <sup>-3</sup>	1.3 x 10 <sup>-2</sup>	4.4 x 10 <sup>-2</sup>	<10 <sup>-2</sup>	<10 <sup>-2</sup>
6	1.0 x 10 <sup>-1</sup>	<10 <sup>-2</sup>	<10 <sup>-2</sup>	<10 <sup>-2</sup>	<10 <sup>-3</sup>	1.2 x 10 <sup>-2</sup>	4.2 x 10 <sup>-2</sup>	<10 <sup>-2</sup>	<10 <sup>-2</sup>
7	9.0 x 10 <sup>-2</sup>	<10 <sup>-2</sup>	1.6 x 10 <sup>-2</sup>	<10 <sup>-2</sup>	<10 <sup>-3</sup>	8.9 x 10 <sup>-3</sup>	3.8 x 10 <sup>-2</sup>	<10 <sup>-2</sup>	<10 <sup>-2</sup>
8	2.1 x 10 <sup>-1</sup>	NM	NM	NM	NM	NM	4.7 x 10 <sup>-2</sup>	NM	NM
9	2.2 x 10 <sup>-1</sup>	NM	NM	NM	NM	NM	5.3 x 10 <sup>-2</sup>	NM	NM
10	2.4 x 10 <sup>-1</sup>	NM	NM	NM	NM	NM	4.2 x 10 <sup>-2</sup>	NM	NM
11	1.7 x 10 <sup>-1</sup>	NM	NM	NM	NM	NM	4.8 x 10 <sup>-2</sup>	NM	NM

34

<sup>a</sup>A number written with "<" prefix means that the concentration of that species in the organic phase was below its detection limit. The number given is the detection limit divided by its aqueous phase concentration.

<sup>b</sup>NM means that the concentration of a species was below the detection limit in both phases.

<sup>c</sup>Stage 7 is the feed stage; stages 1-7 are extraction stages; stages 8 and 9 are scrub one stages; and stages 10 and 11 are scrub two stages.

<sup>d</sup>H<sub>2</sub>Ox = oxalic acid. The distribution ratio was measured by adding <sup>14</sup>C labeled oxalic acid to the near-steady-state solutions of the cold countercurrent run and equilibrating them at 40°C.

<sup>e</sup>NA means not analyzed.

Table IV-15. Distribution Ratios of Fission Products in Each Stage of the Countercurrent Experiment

Stage No.	Distribution Ratio <sup>a, b</sup>								
	Sr	Y	Zr	Mo	Tc <sup>c</sup>	Ru	Rh	Pd	Ag
1	<10 <sup>-2</sup>	1.4	3.3 x 10 <sup>-3</sup>	<10 <sup>-1</sup>	2.7	3.4 x 10 <sup>-2</sup>	<10 <sup>-1</sup>	<10 <sup>-1</sup>	<10 <sup>-1</sup>
2	<10 <sup>-2</sup>	1.4	7.1 x 10 <sup>-3</sup>	<10 <sup>-1</sup>	2.2	3.4 x 10 <sup>-2</sup>	<10 <sup>-1</sup>	<10 <sup>-1</sup>	<10 <sup>-1</sup>
3	<10 <sup>-2</sup>	1.4	1.2 x 10 <sup>-2</sup>	<10 <sup>-1</sup>	NA <sup>d</sup>	3.4 x 10 <sup>-2</sup>	<10 <sup>-1</sup>	<10 <sup>-1</sup>	<10 <sup>-1</sup>
4	<10 <sup>-2</sup>	1.4	1.2 x 10 <sup>-2</sup>	<10 <sup>-1</sup>	NA	3.3 x 10 <sup>-2</sup>	<10 <sup>-1</sup>	<10 <sup>-1</sup>	<10 <sup>-1</sup>
5	<10 <sup>-2</sup>	1.4	1.7 x 10 <sup>-2</sup>	<10 <sup>-1</sup>	2.6	6.8 x 10 <sup>-2</sup>	<10 <sup>-1</sup>	<10 <sup>-1</sup>	<10 <sup>-1</sup>
6	<10 <sup>-2</sup>	1.3	1.6 x 10 <sup>-2</sup>	1.0 x 10 <sup>-1</sup>	2.9	1.1 x 10 <sup>-1</sup>	<10 <sup>-1</sup>	1.7 x 10 <sup>-1</sup>	<10 <sup>-1</sup>
7	<10 <sup>-2</sup>	1.1	1.1 x 10 <sup>-2</sup>	1.1 x 10 <sup>-1</sup>	3.6	3.5 x 10 <sup>-1</sup>	1.1 x 10 <sup>-1</sup>	2.6 x 10 <sup>-1</sup>	<10 <sup>-1</sup>
8	NM	1.2	1.6 x 10 <sup>-1</sup>	NM	2.3	1.2	NM	5.4 x 10 <sup>-1</sup>	NM
9	NM	1.3	NM	NM	2.0	2.3	NM	1.0	NM
10	NM	1.2	NM	NM	7.0 <sup>e</sup>	3.0	NM	1.0	NM
11	NM	1.0	NM	NM	NA	3.0	NM	1.0	NM

(Contd)

Table IV-15. (Contd)

Stage No.	Distribution Ratio <sup>a, b</sup>								
	Cd	Tc	Ba	La	Ce	Pr	Nd	Sm	Eu
1	<10 <sup>-2</sup>	<10 <sup>-2</sup>	<10 <sup>-2</sup>	NM	NM	NM	NM	NM	NM
2	<10 <sup>-2</sup>	<10 <sup>-2</sup>	<10 <sup>-2</sup>	NM	NM	NM	NM	NM	NM
3	<10 <sup>-2</sup>	<10 <sup>-2</sup>	<10 <sup>-2</sup>	3.2	NM	NM	NM	NM	NM
4	<10 <sup>-2</sup>	<10 <sup>-2</sup>	<10 <sup>-2</sup>	3.4	NM	NM	NM	NM	NM
5	<10 <sup>-2</sup>	<10 <sup>-2</sup>	<10 <sup>-2</sup>	3.7	4.6	NM	NM	5.3	4.0
6	<10 <sup>-2</sup>	<10 <sup>-2</sup>	<10 <sup>-2</sup>	3.5	5.1	6.4 <sup>f</sup>	4.4 <sup>f</sup>	5.8	4.2
7	<10 <sup>-2</sup>	<10 <sup>-2</sup>	<10 <sup>-2</sup>	2.9	4.5	5.2 <sup>f</sup>	4.7 <sup>f</sup>	5.1	4.2
8	NM	NM	NM	3.7	6.3	7.0	7.0	7.0	5.6
9	NM	NM	NM	4.2	7.3	8.1	8.3	8.2	7.0
10	NM	NM	NM	4.2	8.7	9.6	9.5	9.5	7.7
11	NM	NM	NM	4.8	7.7	8.1	7.8	7.8	6.2

<sup>a</sup>A number written with "<" prefix means that the concentration of that species in the organic phase was below its detection limit. The number given is the detection limit divided by its aqueous phase concentration.

<sup>b</sup>NM means that the concentration of a species was below the detection limit in both phases.

<sup>c</sup>Tc distribution ratio analysis was performed by taking the near-steady-state solutions from the cold countercurrent run, spiking them with <sup>99</sup>Tc and equilibrating them at 40°C.

<sup>d</sup>NA means not analyzed.

<sup>e</sup>A second contact of the organic with unspiked, fresh aqueous phase gave a Tc distribution ratio of 11.7.

<sup>f</sup>There was an interference in the atomic emission lines for these elements that puts these values in doubt.

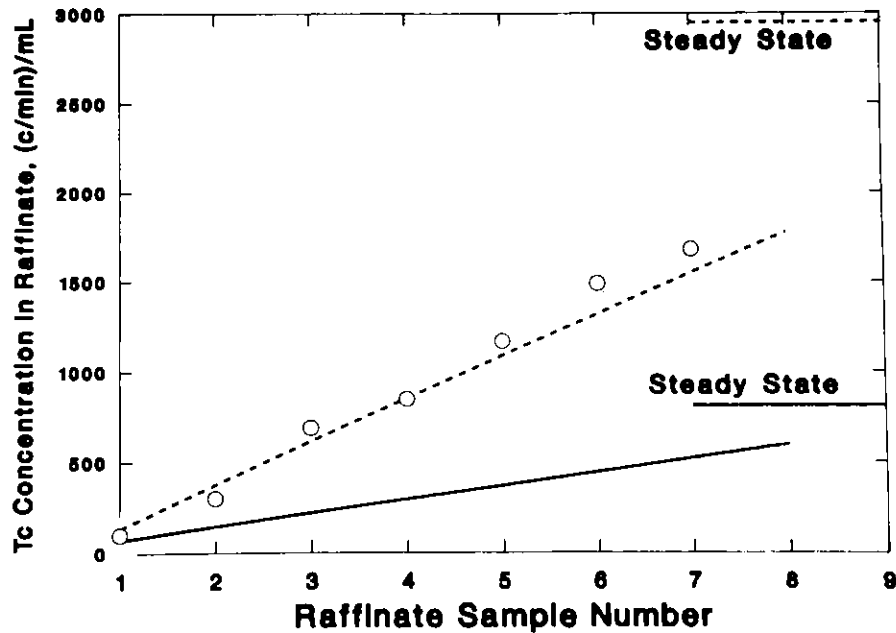

Fig. IV-10. The Raffinate Concentration of  $^{99}\text{Tc}$  vs. the Raffinate Sample Number. (The data are measured raffinate concentrations; the solid line is calculated from measured distribution ratios; and the dash line is an empirical fit of the data.)

## 2. Stripping Behavior of DSW Components

### a. TRU Elements and Uranium

Stripping of the loaded  $\text{O}\phi\text{D}[\text{IB}]\text{CMPO-TRUEX}$  solvent from the countercurrent experiment was accomplished by successive contacts of the loaded organic phase with half-volume portions of fresh ( $0.01\text{M HNO}_3/0.005\text{M HAN}$ ) stripping solution. In an ancillary experiment, a TRUEX solvent solution prepared with purified  $\text{O}\phi\text{D}[\text{IB}]\text{CMPO}^*$  was loaded by a single contact with the proper volume proportions of the feed plus scrub solution 2,<sup>†</sup> followed by a series of four batch scrubs with scrub solution 2. The feed solution used in this experiment was hot DSW feed 2,<sup>†</sup> which contained two hundred times more neptunium than the feed used in the countercurrent experiment. Table IV-16 shows the stripping behavior for Am and Np for a series of consecutive strips of both these loaded organics. In Table IV-16 and the following text, the loaded organic phase from the countercurrent experiment is labeled as TRUEX A and the purified  $\text{O}\phi\text{D}[\text{IB}]\text{CMPO}$  solvent of the ancillary experiment is labeled as TRUEX B. The data in the table are normalized by dividing the concentrations of Am and Np in the organic phase after each strip by their initial concentration.

\*Purified by macroporous anion exchange resin method (see Section V.E for details).

<sup>†</sup>The composition of these solutions is described in Appendix B.

Table IV-16. Americium and Neptunium Stripping Behavior

Contact Number	[Am]/[Am] <sub>initial</sub> Solvent		[Np]/[Np] <sub>initial</sub> Solvent	
	A <sup>a</sup>	B <sup>b</sup>	A <sup>a</sup>	B <sup>b</sup>
1	0.69	0.77	0.95	0.95
2	0.37	0.34	0.91	0.88
3	0.048	0.045	0.64	0.65
4	7.1 x 10 <sup>-3</sup>	4.2 x 10 <sup>-3</sup>	NA <sup>c</sup>	0.48
5	1.4 x 10 <sup>-3</sup>	9.7 x 10 <sup>-4</sup>	NA	0.38
6	5.5 x 10 <sup>-4</sup>	5.3 x 10 <sup>-4</sup>	NA	0.29
7	1.8 x 10 <sup>-4</sup>	d	NA	-
8	7.1 x 10 <sup>-5</sup>	-	0.44	-
9	3.1 x 10 <sup>-5</sup>	-	NA	-
10	<2 x 10 <sup>-6</sup>	-	NA	-

<sup>a</sup>Loaded organic solvent from the countercurrent experiment.

<sup>b</sup>Loaded organic phase of purified O<sub>4</sub>D[IB]CMPO TRUEX solvent loaded with a single contact of hot DSW feed solution 2 (Appendix B, Table A-3) followed by multiple scrubs.

<sup>c</sup>NA means not analyzed.

<sup>d</sup>Stripping of TRUEX B by dilute HNO<sub>3</sub>-HAN strip solution was terminated after six contacts.

The stripping characteristics of Am for both loaded organic phases seem adequate, although the presence of acid extractants is probably responsible for the large number of contacts required to reduce the Am count rate to background. Neptunium stripping, although slightly better in the purified CMPO solvent, is not adequate for either solvent.

There were, however, striking differences between the two TRUEX solvents with respect to their plutonium stripping behavior and their disengagement times and crud forming properties. Only 5% of the plutonium was stripped from the TRUEX A organic phase after seven contacts; however, >99% Pu was stripped from TRUEX B organic phase after six contacts. This difference could be due to (1) the much lower level of acidic impurity in the purified solvent or (2) the higher concentration of neptunium in the organic phase tying up acidic extractants or (3), most probably, a combination of both (1) and (2).

As a backup stripping and possible solvent cleanup procedure, a portion of TRUEX A, which had received eight contacts with the diluent nitric

acid/HAN strip solution, was contacted with a 0.1M  $H_2C_2O_4$  solution (strip solution 2). After two contacts using an O/A phase ratio of 4:1, the neptunium concentration in the organic phase dropped by two orders of magnitude. Plutonium, by analogy, should show a similar behavior. The oxalic acid strip also effectively removed the remaining uranium from the TRUEX solvent (the contacts with the 0.01M  $HNO_3$ /0.005M HAN strip solution removed <10% of the uranium in the TRUEX A solution).

A qualitative description of the stripping behavior of the TRU elements is presented in Table IV-17.

Table IV-17. A Qualitative Summary of the Stripping Behavior of TRU Elements from Loaded CMPO-TRUEX Solvent

Element	Strip Solution 1 <sup>a</sup>	Strip Solution 2 <sup>b</sup>
Pu	Not adequate	Adequate
Np	Not adequate	Adequate
Am	Adequate	--

<sup>a</sup>0.01M  $HNO_3$ /0.005M HAN

<sup>b</sup>0.1M  $H_2C_2O_4$

#### b. Other DSW Components

Before stripping, the combined loaded organic phase of the cold countercurrent experiment received two additional scrubs with 0.5M  $HNO_3$ -0.01M  $Fe^{3+}$  to ensure complete removal of extracted oxalic acid and to minimize the concentration of nitric acid in the organic phase. Stripping of the resultant organic phase was performed in a separatory funnel by successive contacts with strip solution 1 using an O/A phase ratio of two. Six successive strips were performed. The color of the organic phase changed from yellow to tan as stripping proceeded, but all strips were colorless. Samples of the successive aqueous phase contacts were tested for the presence of rare earths by addition of oxalic acid. The first contact contained a small quantity of precipitate, indicating that excess  $HNO_3$  was effectively removed by scrub 2. The third and fourth contacts contained the bulk of the rare earths, as indicated by the volume of oxalate precipitates, whereas the sixth contact gave no precipitate. The combined rare earth oxalate precipitate had a light blue-gray color, probably from the presence of neodymium ions.

Analysis of a sample of the combined strips were performed with ICP/AES. The results are shown in Tables IV-18 and IV-19. As can be seen from the data, the metal ion composition of the strip solution is 94.2% lanthanides and yttrium, with small quantities of Fe, Ru, Rh, and Pd. Because of the low distribution ratios of yttrium and to some extent lanthanum, 72% of the



Table IV-18. Composition of the Combined Dilute Nitric Acid Strips of Loaded Organic from Cold Countercurrent Run

Element	Wt. % Metal Ion Composition of the Strip Solution
Rare Earth + Y	94.2
Fe	2.6
Ru	2.1
Rh	0.4
Pd	0.7
All Other Constituents	ND <sup>a</sup>

<sup>a</sup>ND means not detectable.

Table IV-19. Composition of Rare Earths and Yttrium in the Feed and the Combined Strip

Element	Wt. % Composition in Feed	Wt. % Composition in Strip
La	12.1	10.9
Ce	29.1	31.3
Pr	11.3	12.5
Nd	35.5	36.7
Sm	5.4	6.0
Eu	0.8	0.8
Y	5.8	1.8

yttrium and 18% of the lanthanum reported to the raffinate under conditions in which only 0.01% of the Am(III) was detected in the raffinate.

A separate stripping experiment was performed on Tc because of the complexity of the analysis. Technetium was spiked into a cold feed solution and extracted and scrubbed at 40°C using the appropriate phase ratio. Multiple strippings showed that 94% of the Tc was stripped after ten contacts. The 0.1M H<sub>2</sub>C<sub>2</sub>O<sub>4</sub> strip solution was somewhat more effective.

### c. Disengagement Behavior

The cleanup of the CMPO-TRUEX solvent was determined to be a major factor in shortening disengagement times for stripping and for preventing crud formation. The disengagement times for the purified TRUEX B solution were in the range of 15 seconds; under the same conditions, it took at least a minute for the TRUEX A solutions to separate. In fact, after the fifth contact with the dilute HNO<sub>3</sub> strip solution, a small quantity of a lipophilic precipitate formed in the TRUEX A solvent. This solid, which increased phase disengagement time, was probably dioctylphosphine oxide.

Disengagement times between TRUEX A solvent and the 0.1M  $H_2C_2O_4$  strip solution were less than one minute and showed no problems with crud formation.

### 3. Relevance of Results to TRU Decontamination

One can calculate the TRU contamination of the solidified raffinate in grout by assuming: (1) the concentrations of TRU elements believed to be appropriate for DSW (presented in Table IV-20), (2) the composition of the solidified raffinate based on the results of the countercurrent experiment (presented in Table IV-21), (3) the salt content of the grout as 20%,\* and (4) the decontamination factors for the countercurrent experiment presented in Table IV-13. The results of the calculations are summarized in Table IV-22. To calculate the unit activity level in terms of nanocuries per gram of raffinate, one must divide the activity level of each radionuclide in the feed (in units of nanocuries per liter of feed) by its decontamination factor and again by the amount of solid raffinate (230 g) derived from each liter of feed. To calculate the TRU contamination in the grout, one must multiply the activity level in the solidified raffinate by its dilution factor in the grout (assumed to be 0.2 for this calculation).

Table IV-20. Concentration of TRU Elements and Uranium in Hanford CAW and DSW

Element	Concentration			
	g/L	$\bar{M}$	dpm/L	Ci/L
U	0.03	$1 \times 10^{-4}$	a	a
$^{237}\text{Np}$	0.05	$2 \times 10^{-4}$	$8 \times 10^7$	$4 \times 10^{-5}$
$^{239}\text{Pu}$	$4 \times 10^{-4}$	$2 \times 10^{-6}$	$5 \times 10^7$	$2 \times 10^{-5}$
$^{241}\text{Am}$	0.04	$2 \times 10^{-4}$	$3 \times 10^{11}$	$1 \times 10^{-1}$

<sup>a</sup>Negligible.

The results of this calculation (Table IV-22) show that the laboratory (10 stage) batch countercurrent experiment was sufficient to decrease the TRU levels in the product to well below 100 nCi/g solid.

### 4. The TRU Product Composition

Based on the stripping data for the cold countercurrent experiment (Tables IV-18 and 19), the composition of the feed (Table B-2, Appendix B), the distribution ratios of the lanthanides in each stage (Table IV-15), the

\*Before the use of grout is considered,  $^{90}\text{Sr}$  must be removed from the raffinate.

Table IV-21. Probable Species in Solidified Raffinate and Their Masses per Volume of Feed

Component	Mass of Component per Liter of Feed, g
NaNO <sub>3</sub> <sup>a</sup>	138.52
Na <sub>2</sub> SO <sub>4</sub>	1.51
Fe(NO <sub>3</sub> ) <sub>3</sub> ·9H <sub>2</sub> O	60.75
FePO <sub>4</sub> ·4H <sub>2</sub> O	0.72
Mg(NO <sub>3</sub> ) <sub>2</sub> ·6H <sub>2</sub> O	0.26
Al(NO <sub>3</sub> ) <sub>2</sub> ·9H <sub>2</sub> O	16.26
Al <sub>2</sub> F <sub>6</sub> ·7H <sub>2</sub> O	0.39
CaSO <sub>4</sub>	0.18
Cr(NO <sub>3</sub> ) <sub>3</sub> ·25H <sub>2</sub> O	5.04
Mn(NO <sub>3</sub> ) <sub>2</sub> ·6H <sub>2</sub> O	1.29
Ni(NO <sub>3</sub> ) <sub>2</sub> ·6H <sub>2</sub> O	2.33
Cu(NO <sub>3</sub> ) <sub>2</sub> ·6H <sub>2</sub> O	0.52
Zr(NO <sub>3</sub> ) <sub>4</sub> ·5H <sub>2</sub> O	2.40
Ba(NO <sub>3</sub> ) <sub>2</sub>	0.29
Total	230.46

<sup>a</sup>Includes the NaNO<sub>3</sub> formed when the 1.5 moles of HNO<sub>3</sub> in 1.33 liters of raffinate are neutralized with NaOH.

Table IV-22. Summary of Calculations for TRU Content of Solidified Raffinate

Radionuclide	Activity in Feed, nCi/L	Decontamination Factor	Activity in Solidified Raffinate, <sup>a</sup> nCi/g	Activity in Grout, <sup>b</sup> nCi/g
Am	1 x 10 <sup>8</sup>	1.0 x 10 <sup>4c</sup>	40	8
Pu	2 x 10 <sup>4</sup>	>1 x 10 <sup>5</sup>	<2 x 10 <sup>-3</sup>	-
Np	4 x 10 <sup>4</sup>	6	30	6
Total	1 x 10 <sup>8</sup>	-	70	14

<sup>a</sup>If the stage 0 decontamination factor were used, the Am specific activity would drop to 9 nCi/g and the total specific activity to 40 nCi/g.

<sup>b</sup>If the stage 0 decontamination factor were used, the Am specific activity would drop to 2 nCi/g and the total specific activity to 8 nCi/g.

<sup>c</sup>This is the measured decontamination factor for the raffinate from stage 1 of the countercurrent experiment. This was followed by a batch contact of the raffinate with fresh TRUEX solvent (stage 0) that increased the D.F. to 4.6 x 10<sup>4</sup>.

concentration of TRU in the simulated DSW feed (Table IV-20), and the decontamination factors for the TRU elements (Table IV-13), one can describe the composition and activity level of the TRU product.

With distribution ratios of Pr, Nd, and Sm all above five in the extraction and scrub sections, one would assume that they report in greater than 99% abundance to the TRU product. The fact that the relative ratios of these species in the feed and in the strip solutions are experimentally identical is confirmation of this assumption. The composition of any of these three elements in the feed could therefore be used to calculate the weight of all other components of the TRU product, using Tables IV-18 and IV-19. The summary of this calculation using the concentration of Nd (in units of g/L) in the feed and its weight percent in the strip solution is shown in Table IV-23.

Table IV-23. Calculation of the Non-TRU Composition of Solidified TRU Product

Element	Wt. Relative to Wt. of Nd	Wt. of Metal per Liter of Feed, <sup>a</sup> g	Form of Oxide	Wt. of Oxide per Liter of Feed, g
La	0.34	0.13	La <sub>2</sub> O <sub>3</sub>	0.15
Ce	0.82	0.32	CeO <sub>2</sub>	0.39
Pr	0.32	0.12	Pr <sub>6</sub> O <sub>11</sub>	0.14
Nd	1	0.39	Nd <sub>2</sub> O <sub>3</sub>	0.45
Sm	0.15	0.06	Sm <sub>2</sub> O <sub>3</sub>	0.07
Eu	0.02	0.01	Eu <sub>2</sub> O <sub>3</sub>	0.01
Y	0.16	0.06	Y <sub>2</sub> O <sub>3</sub>	0.08
Fe	0.05	0.02	Fe <sub>2</sub> O <sub>3</sub>	0.03
Ru	0.06	0.02	RuO <sub>2</sub>	0.02
Rh	0.02	0.01	Rh <sub>2</sub> O <sub>3</sub>	0.01
Pd	0.02	0.01	PdO	0.01
Total	--	--	--	1.36 <sup>b</sup>

<sup>a</sup>One liter of feed contains  $2.7 \times 10^{-3}$  mol (0.39 g) of Nd.

<sup>b</sup>89% of the technetium in the feed will be in the TRU product.

Along with the 1.36 g of non-TRU oxides in the product would be 0.12 g of actinides (Table IV-20); therefore, one liter of feed would generate 1.5 g of TRU product with a specific alpha activity in the solid oxide product of 0.07 Ci/g.

### C. Modifications for an Improved TRU EX Flowsheet

The results of the batch countercurrent experiments have revealed areas for improving the CMPO-TRU EX process for TRU removal from DSW:

- The split scrub can be eliminated. A single scrub with 0.5M HNO<sub>3</sub>-0.005M Fe<sup>3+</sup> having an O/A phase ratio of four should be sufficient to decontaminate the loaded organic phase from fission products and entrained feed solution.

• The O/A phase ratio of the dilute  $\text{HNO}_3$  strip should be decreased from 2 to 1, and the concentration of  $\text{HNO}_3$  increased to  $0.02\text{M}$ , thus increasing the efficiency of stripping Am, Pu, Np, and Tc.

• The concentration of oxalic acid in the second strip should be decreased from 0.1 to  $0.05\text{M}$  to minimize the quantity of organic compound that must be destroyed.

The above changes are incorporated in the modified flowsheet shown in Fig. IV-11.

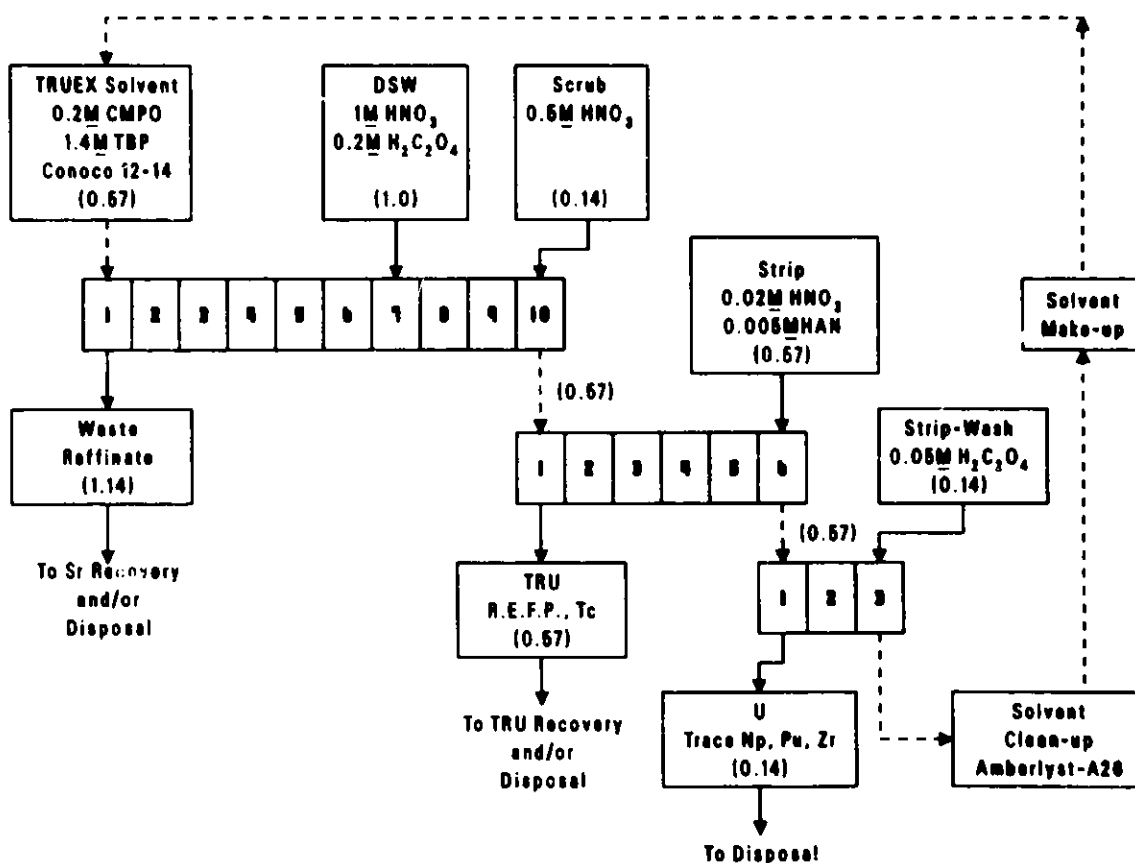

Fig. IV-11. An Improved CMPO-TRUEX Flowsheet for DSW Feed. (The number in parentheses in each box is the relative flow rate of that stream.)

## V. TRUEX PROCESS CHEMISTRY AND FLOWSHEET FEATURES

Because of its high degree of flexibility in removing soluble TRU elements from a wide variety of feeds, the TRUEX process is applicable to many actinide separations in nuclear and defense activities. Process flexibility and other chemical process concerns (third-phase formation, chemical and radiolytic stability of TRUEX solvents, and the aqueous phase solubility and physical parameters of TRUEX reagents) are discussed in this section. Also addressed below are other features important to judging the appropriateness of a TRUEX process. These features include cost and commercial availability of the extractants, estimated extractant loss and inventory, process equipment concerns, and process safety. There is a great deal more process information available in the literature for the less acceptable TRUEX process extractant, DHDECMP, and most of the ANL effort has been directed toward studying the properties of O $\phi$ D[IB]CMPO.

### A. Process Flexibility

The CAW and DSW feed compositions for the TRUEX process flowsheets were based on the best information available. There is also a general knowledge of variations in CAW composition. The composition of DSW, however, is based on a conceptual process that includes dissolving the sludge in oxalic acid and/or nitric acid, mixing, adjusting the volume to that of the original CAW, and perhaps adjusting the nitric acid and the oxalic acid concentrations. Because of the complexities of obtaining the DSW feed, there is bound to be a high variability in its composition.

Studies at the Savannah River Plant (SRP) determined that 8% (1M) solutions of oxalic acid can dissolve ~95% of PUREX process sludge at practical rates [BRADLEY, SRL-1976, -1978]. A combination of sluicing [RASMUSSEN] and oxalic acid dissolution could be used for preparing DSW.

The following discussion deals with the effects of varying temperature and the concentrations of nitric and oxalic acid in the feed on the extraction of Am and other feed constituents. Also, briefly discussed are the effects of varying the solvent concentrations of TBP and the extractant.

#### 1. Nitric Acid Concentration

Because O $\phi$ D[IB]CMPO and DHDECMP are neutral extractants, cationic species must extract as neutral salts from nitric acid medium. For example, the extraction of americium is accomplished through the reaction:



where E is the neutral extractant (DHDECMP or O $\phi$ D[IB]CMPO) or its 1/1 nitric acid adduct (E-HNO<sub>3</sub>). The [HNO<sub>3</sub>] in the feed, therefore, acts as a salting agent (i.e., a source for NO<sub>3</sub><sup>-</sup>) and increases the extent of the extraction of americium and other cations as nitrate salts. Extraction of nitric acid itself also increases with increasing [HNO<sub>3</sub>] and can, therefore, limit the extraction power of the solvent for other species by competing for extractant molecules. Figure V-1 shows how these competing reactions affect the distribution coefficient of americium.

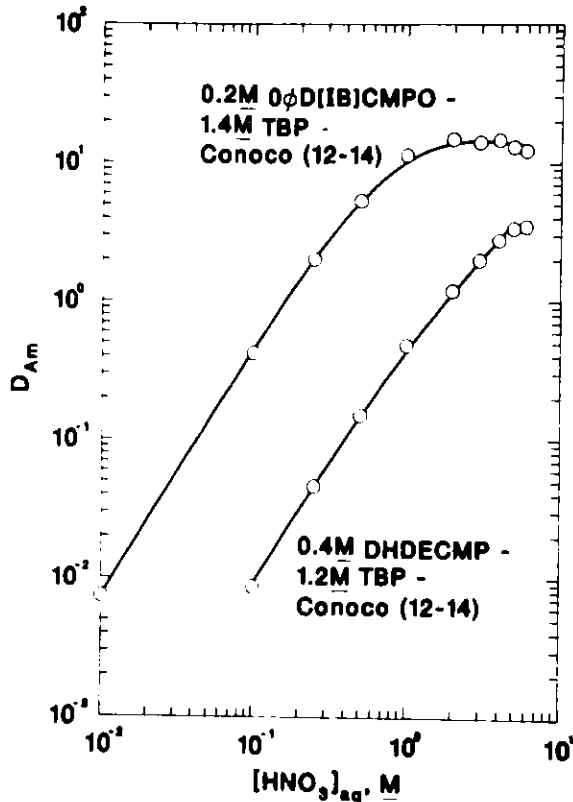

Fig. V-1.

The Distribution Ratio of Am vs.  $[\text{HNO}_3]$  for the TRUEX Solvents (at  $40^\circ\text{C}$  with a 1/1 Phase Ratio)

Figure V-2 shows how the nitric acid concentration affects the partitioning of oxalic acid and pertechnetate ion by the TRUEX process solvents. Because both of these species extract into the organic phase as acids, the extraction mechanism is different from that of Eq. 1. In these extractions, nitric acid is acting as a hydrogen ion donor:



to form the extractable neutral species. The nitric acid concentration of the organic phase is also plotted in Fig. V-2 vs. that of the aqueous phase. The average distribution ratio of  $\text{HNO}_3$  calculated from the data presented in Fig. V-2 is  $\sim 0.3$ .

Because the shapes of the curves shown in Figs. V-1 and V-2 are based on competition of two reactions that are competing for extractant molecules, they will be modified by the relative concentrations of the extracting species. The distribution ratios of Am, Tc, and  $\text{H}_2\text{C}_2\text{O}_4$  were all measured at radiotracer concentrations of these species. At higher concentrations, they would compete more effectively for extractant molecules, and the maximum of each curve would be shifted to higher aqueous-phase nitric acid concentrations. Because the mechanisms for extraction of  $\text{H}_2\text{C}_2\text{O}_4$  and  $\text{HTcO}_4$  are so similar to those of  $\text{HNO}_3$ , this effect is clearer than for Am extraction, where  $\text{HNO}_3$  and  $\text{Am}(\text{NO}_3)_3$  are simultaneously extracted.

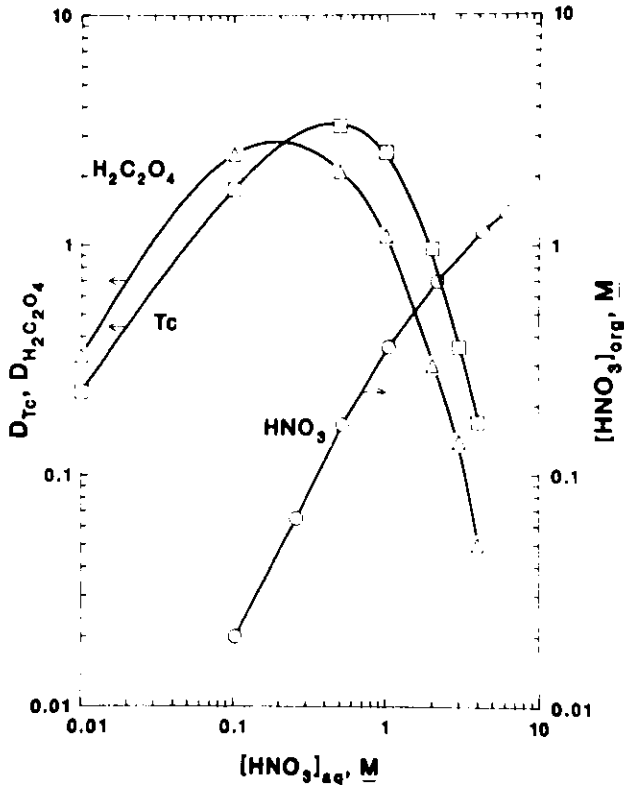

Fig. V-2.

The Organic-Phase  $[\text{HNO}_3]$  and the Distribution Ratios of Oxalic Acid and Pertechnic Acid vs. the Aqueous-Phase  $[\text{HNO}_3]$  for CMPO-TRUEX Solvent. (The distribution ratio data for oxalic acid, represented by triangles, and pertechnetate, represented by squares, were measured at  $40^\circ\text{C}$ ; the organic phase concentrations of  $\text{HNO}_3$ , displayed as circles, were measured at  $25^\circ\text{C}$ , all at a 1/1 phase ratio. The CMPO-TRUEX solvent is  $0.2\text{M}$   $\text{O}\phi\text{D}[\text{IB}]\text{CMPO}-1.4\text{M}$  TBP-Conoco  $\text{C}_{12}-\text{C}_{14}$ .)

An important difference between the two TRUEX process solvents is made evident by the data in Fig. V-1. Because of the negligible effect of  $[\text{HNO}_3]$  on its extraction power in the range of  $3-6\text{M}$   $\text{HNO}_3$ , DHDECMP is an effective extractant for separating americium from fission products at high acid concentrations. Near  $1\text{M}$   $\text{HNO}_3$ , however, small differences in acidity have a profound effect on DHDECMP extraction of americium [ $D_{\text{Am}}(2\text{M } \text{HNO}_3) = 1.4$ ;  $D_{\text{Am}}(1\text{M } \text{HNO}_3) = 0.48$ ;  $D_{\text{Am}}(0.5\text{M } \text{HNO}_3) = 0.15$ ]-a range of almost 10 occurring for a fourfold change in nitric acid concentration. The data presented in Fig. V-1 show that the CMPO-TRUEX process solvent is much more suitable for use with feeds having a nitric acid concentration near  $1\text{M}$ . Addition of nitrate ion to the feeds will, of course, increase the extracting power of both TRUEX solvents for species that extract as nitrate salts.

## 2. Oxalic Acid Concentration

Oxalic acid is added to the feed solution to inhibit the extraction of troublesome fission products (i.e., Pd, Zr, and Mo) and iron by forming inextractable aqueous phase oxalato-complexes. Tables V-1 and V-2 show the influence of oxalic acid concentration on the extraction of a variety of metal ions from a simulated waste solution that is similar in composition to DSW. Table V-3 shows some more recent data, obtained for a slightly different composition of the  $\text{O}\phi\text{D}[\text{IB}]\text{CMPO}-\text{TRUEX}$  solvent (namely,  $0.2\text{M}$   $\text{O}\phi\text{D}[\text{IB}]\text{CMPO}-1.4\text{M}$  TBP-Conoco  $\text{C}_{12}-\text{C}_{14}$ ) and the simulated DSW solution prepared for the counter-current experiment.



Table V-1. Distribution Ratios of DSW Components<sup>a</sup> vs. Aqueous-Phase [H<sub>2</sub>C<sub>2</sub>O<sub>4</sub>] for a CMP-TRUEX Process Solvent<sup>b</sup>

Element	Distribution Ratio <sup>c,d</sup>			
	0M	0.05M	0.1M	0.2M
Sr	<0.013	<0.013	<0.013	<0.013
Y	0.356	0.33	0.27	0.24
Zr	1.48	0.18	0.030	<0.002
Mo	0.091	0.046	0.036	0.026
Ru	0.47	0.36	0.31	0.26
Rh	<0.091	<0.091	<0.091	<0.095
Pd	0.57	0.54	0.53	0.50
Cd	<0.05	<0.05	<0.05	<0.067
Ba	0.36	<0.015	<0.011	<0.014
La	2.40	2.20	1.71	1.39
Ce	2.40	2.31	1.79	1.44
Pr	2.18	2.02	1.64	1.33
Nd	1.81	1.75	1.53	1.19
Sm	1.59	1.52	1.29	0.97
Eu	1.32	1.29	1.10	0.86
Mg	<0.032	<0.033	<0.033	<0.034
Ca	0.18	0.091	0.093	0.095
Cr	9.5x10 <sup>-4</sup>	9.7x10 <sup>-4</sup>	9.8x10 <sup>-4</sup>	9.8x10 <sup>-4</sup>
Mn	0.0078	0.0060	0.0051	0.0051
Fe	0.0076	0.0063	0.0051	0.0035
Ni	0.0035	<0.0013	<0.0013	<0.0013
Cu	<0.0056	<0.0056	<0.0057	<0.0057
Al	<0.0045	<0.0045	<0.0045	<0.0045

<sup>a</sup>Run at 40°C with an O/A phase ratio of 0.5.

<sup>b</sup>The CMP-TRUEX process solvent was 0.5M DHDECMP/1.0M TBP/SRP diluent. The SRP diluent is a sample of the NPH diluent used in the Savannah River Plant PUREX Process, approximately 5 years ago.

<sup>c</sup>Concentrations are for H<sub>2</sub>C<sub>2</sub>O<sub>4</sub>.

<sup>d</sup>When a distribution ratio is given as "<" a quantity, the organic phase concentration of that element is below detectability; the reported ratio is the detectability limit divided by the aqueous phase concentration of that species.

Table V-2. Distribution Ratios of DSW Components<sup>a</sup> vs. Aqueous-Phase [H<sub>2</sub>C<sub>2</sub>O<sub>4</sub>] for a CMPO-TRUEX Process Solvent<sup>b</sup>

Element	Distribution Ratio <sup>c,d</sup>			
	0M	0.05M	0.1M	0.2M
Sr	<0.0046	<0.0048	<0.0046	<0.0047
Y	1.78	1.77	1.70	1.56
Zr	13.00	1.44	0.24	0.02
Mo	1.21	0.81	0.44	0.28
Ru	0.35	0.31	0.33	0.32
Rh	0.19	<0.09	<0.10	<0.11
Pd	1.58	1.13	0.71	0.44
Cd	<0.07	<0.08	<0.07	<0.07
Ba	0.027	<0.014	<0.011	0.012
La	6.14	5.86	5.03	4.46
Ce	9.78	9.51	8.28	7.37
Pr	12.03	10.49	9.07	8.31
Nd	10.64	9.78	8.46	7.18
Sm	9.62	9.40	7.95	7.16
Eu	8.38	8.00	7.00	6.30
(Am)	11	11	9.4	8.4
Mg	<0.029	<0.030	<0.029	<0.030
Ca	0.082	0.093	0.087	0.089
Cr	<0.001	<0.001	<0.001	<0.001
Mn	0.0076	0.0102	0.0087	0.0087
Fe	0.06	0.06	0.05	0.03
Ni	0.0036	0.0043	0.0026	<0.001
Cu	<0.0006	<0.006	<0.006	<0.006
Al	6.2x10 <sup>-3</sup>	6.6x10 <sup>-3</sup>	4.2x10 <sup>-3</sup>	4.2x10 <sup>-3</sup>

<sup>a</sup>Run at 40°C with an O/A phase ratio of 0.5.

<sup>b</sup>The CMPO-TRUEX process solvent was 0.2M O<sub>2</sub>D[IB]CMPO/1.2M TBP/Norpor-12 diluent. The Norpor-12 diluent is a commercial NPH with an average carbon chain length of 12.

<sup>c</sup>Concentrations are for H<sub>2</sub>C<sub>2</sub>O<sub>4</sub>.

<sup>d</sup>When a distribution ratio is given as "<" a quantity, the organic phase concentration of that element is below detectability; the reported ratio is the detectability limit divided by the aqueous phase concentration of that species.

Table V-3. Distribution Ratios of DSW Components vs. Aqueous-Phase [H<sub>2</sub>C<sub>2</sub>O<sub>4</sub>] under Conditions Used for Flowsheet Verification by the Batch Countercurrent Experiment<sup>a</sup>

Element	Distribution Ratio <sup>b,c</sup>		
	0.05M	0.10M	0.20M
Sr	<10 <sup>-2</sup>	<10 <sup>-2</sup>	<10 <sup>-2</sup>
Y	1.5	1.5	1.1
Zr	0.58	0.13	0.013
Mo	0.80	0.31	0.11
Tc	NA <sup>d</sup>	NA	3.0
Ru	0.39	0.38	0.30
Rh	0.078	0.080	0.11
Pd	0.71	0.65	0.44
Cd	<0.04	<0.04	<0.05
Ba	<10 <sup>-2</sup>	<10 <sup>-2</sup>	<10 <sup>-2</sup>
La	5.2	5.0	3.4
Ce	8.2	8.2	5.4
Pr	9.1	8.0	5.7
Nd	9.0	8.6	5.6
Sm	7.9	7.8	5.1
Eu	6.8	6.8	4.4
Am	10.0	10.0	6.1
Al	0.012	0.0097	<0.006
Mn	8.5 x 10 <sup>-3</sup>	9.5 x 10 <sup>-3</sup>	10 <sup>-2</sup>
Fe	0.057	0.057	0.041
Cu	0.014	0.014	<0.007

<sup>a</sup>The organic phase was 0.2M O<sub>2</sub>D[IB]CMPO/1.4M TBP/Conoco C<sub>12</sub>-C<sub>14</sub> diluent. The Conoco C<sub>12</sub>-C<sub>14</sub> diluent is a commercially available NPH with an average carbon chain length of 13. The experiments were at 40°C, with an O/A phase ratio of 0.5; the simulated DSW was used in the batch countercurrent experiment.

<sup>b</sup>Measured by inductively coupled plasma/atomic emission spectroscopy except for Tc, which was measured by radiotracer analysis. Concentrations are for H<sub>2</sub>C<sub>2</sub>O<sub>4</sub>.

<sup>c</sup>When a distribution ratio is given as "<" a quantity, the organic phase concentration of that element is below detectability; the reported ratio is the detectability limit divided by the aqueous phase concentration of that species.

<sup>d</sup>NA means not analyzed.

The data of Tables V-1, V-2, and V-3 show the importance of using fairly high concentrations (0.2M) of oxalic acid to lower the extractability of the troublesome elements; this is accomplished at the cost of reducing the distribution ratio of lanthanides and TRU elements. In fact, if the concentration of oxalate is made too high, precipitation of lanthanides and TRU elements might occur. Because the great proportion of oxalate is tied up in the CAW and DSW feed solutions as oxalate complexes of iron and aluminum, the total oxalate concentration would have to be considerably higher than 0.3M, the highest  $[H_2C_2O_4]$  that has been studied. The reader is directed to Appendix C for a discussion on oxalic acid complexing of CAW and DSW components and the effect of this complexing on the composition of these solutions.

The actinide-oxalate complexation data in Appendix C show that both Pu(IV) and Np(IV) will be largely complexed in the aqueous feed when the total oxalic acid concentration is 0.2M. Because these two TRU species should have a distribution ratio between 1M  $HNO_3$  and the TRUEX solvents in the range of  $10^4$ , complexation with oxalate should not hinder these species from partitioning to the organic phase. Addition of oxalate to the feed is also important because it should reduce Np(V) to the much more extractable Np(IV) species [HORWITZ-1983].

The amount of oxalic acid in the TRU/lanthanide-rich organic phase does become important in the strip section, however, where there is no iron or aluminum ion in the aqueous strip solution to complex with oxalate. The double scrub is included in the extraction section to minimize the amount of oxalic acid in the loaded solvent and, therefore, prevent lanthanide/TRU precipitation during stripping.

### 3. Temperature

Data presented in Table V-4 show the typical effect of temperature on the extraction of metal ions--the distribution of  $Am^{3+}$  decreases with increasing temperature for both TRUEX process extractants. The positive aspects of increasing temperature (faster phase disengagement and elimination of third phases) are discussed in Section V.B.

### 4. Tributyl Phosphate

The role of TBP in TRUEX process solvent is primarily one of a phase modifier; i.e., it allows the extraction of gross amounts of actinides and lanthanides without third-phase formation. Further discussion of the role of TBP is given in Section V.B, which is concerned with third-phase formation.

The addition of TBP to TRUEX process solvents also has a second benefit: it modifies the extracting power of  $O\phi D[IB]CMPO$ . The influence of TBP addition on  $D_{Am}$  for various nitric acid concentrations is illustrated in Fig. V-3. At low nitric acid concentrations, the addition of TBP lowers  $D_{Am}$  and facilitates stripping. At high  $HNO_3$  concentrations, where extraction will occur, TBP has the effect of flattening the curve, thus diminishing the effect of varying nitric acid concentration on the extraction of americium.

Table V-4. Influence of Temperature on the Extraction of Americium and Europium by TRUEX Process Solvents<sup>a</sup>

Temp., °C	DHDECMP			O $\phi$ D[IB]CMPO		
	D <sub>Am</sub>	D <sub>Eu</sub>	D <sub>Am</sub> /D <sub>Eu</sub>	D <sub>Am</sub>	D <sub>Eu</sub>	D <sub>Am</sub> /D <sub>Eu</sub>
20	third-phase formation			third-phase formation		
30	6.97	5.24	1.33	19.6	14.6	1.34
40	5.62	4.29	1.31	15.8	11.9	1.33
50	4.60	3.56	1.29	12.1	9.44	1.28

<sup>a</sup>The distribution ratios of americium and europium (D<sub>Am</sub> and D<sub>Eu</sub>) were measured between CAW solution containing 0.1M oxalic acid and the TRUEX solvents (0.2M O $\phi$ D[IB]CMPO/1.2M TBP/Norpar-12 and 0.5M DHDECMP/1.0M TBP/Norpar-12; O/A Phase Ratio = 0.5).

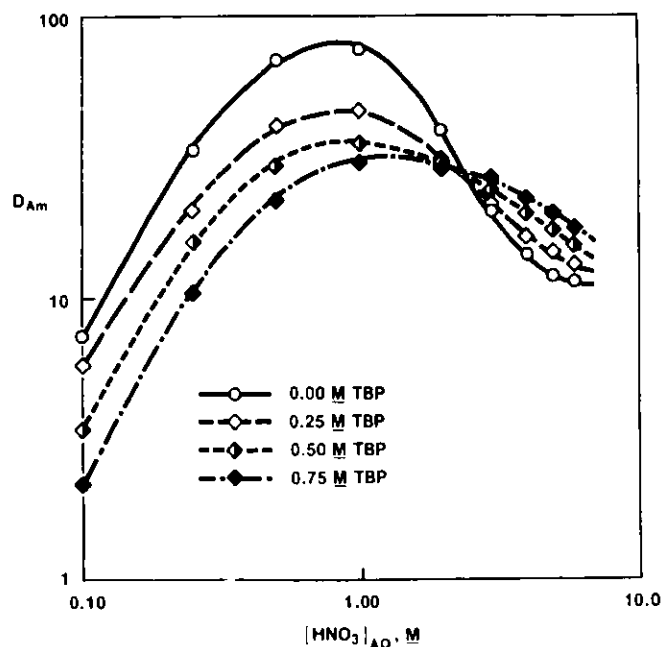

Fig. V-3.

Acid Dependency of D<sub>Am</sub> for 0.25M O $\phi$ D[IB]CMPO in Decalin as a Function of Added TBP at 25°C

### B. Diluent Properties and Phase Compatibility

Studies of factors that influence the formation of heavy organic phases in the extractant mixtures of TBP with the bifunctional compounds DHDECMP and O $\phi$ D[IB]CMPO have defined regimes where undesirable third-phase (second organic phase) formation can occur. Factors of major importance include (1) choice of diluent, (2) organic phase concentration of TBP, (3) type and concentration of bifunctional extractant, (4) aqueous phase acidity, and (5) temperature. These five factors and other considerations are discussed below.

## 1. Choice of Diluent

The compositions of these three commercially available NPH mixtures (Norpar 12, SRP diluent,\* and Conoco C<sub>12</sub>-C<sub>14</sub>) are presented in Table V-5. Solutions of 0.20M O $\phi$ D[IB]CMPO/1.2M TBP in each diluent were examined for loading capacity by extracting Nd(NO<sub>3</sub>)<sub>3</sub> from 3.0M HNO<sub>3</sub> at 25°C, with dramatically different results (Table V-6). A similar effect was found for DHDECMP/TBP mixtures. Obviously, the changes in the relative concentrations of the C<sub>10</sub> to C<sub>15</sub> components in these diluents severely alter the loading capacity of the solvent. The large differences in loading capacities of TRUEX-process extractant solutions in three similar commercially available NPH diluents led to a more complete study of loading capacity vs. carbon chain length. To examine this phenomenon, studies of solutions with the same extractant composition in pure aliphatic diluents were carried out (Table V-6). The drop in loading from essentially 100% of theoretical for decane to 0% for preconditioned organic solutions in the C<sub>14</sub> and C<sub>16</sub> diluents is evident. The values obtained for the commercial diluents correlate well with the loading that would be predicted based on the average chain length. Results obtained for the loading of solutions with the same extractant concentration in different C<sub>12</sub>-C<sub>13</sub> mixtures (bottom of Table V-6) demonstrate the large effect even a relatively low concentration of a longer chain aliphatic can have on loading.

Table V-5. Composition of NPH Diluents

Carbon Chain Length	Norpar-12	SRP	Conoco C <sub>12</sub> -C <sub>14</sub>
10	13	-	1
11	36	0.5	2
12	44	9.5	12
13	7	48	56
14	-	40	28
15	-	2	1
Av.	11.45	13.34	13.23

## 2. TBP Concentration

Although not studied in detail, the limited data show the effect of TBP concentration on phase compatibility of the bifunctional extractants to be great. Without added TBP, the bifunctional compounds cannot be used as extractants in NPHs due to third-phase formation on contact with acidic aqueous solutions. Earlier studies showed that only with quite high concentrations of TBP, or other polar compounds, can CMP and CMPO extractants be made compatible with aliphatic diluents [HORWITZ-1984]. For 0.20M O $\phi$ D[IB]CMPO in Norpar-12, a TBP concentration of 1.2M is sufficient to obtain adequate

\*A PUREX diluent in use at the Savannah River Plant ~5 years ago.

Table V-6. Effect of Diluent on the Loading Capacity of CMPO-TRUEX Process Solvents<sup>a</sup>

Diluent	%, Loading <sup>b,c</sup>
Norpar-12	70-75
Conoco	25-30
SRP	20-25
Decane (C <sub>10</sub> )	100
Dodecane (C <sub>12</sub> )	70-75
Tridecane (C <sub>13</sub> )	30-35
Tetradecane (C <sub>14</sub> )	d
Hexadecane (C <sub>16</sub> )	d
100% C <sub>12</sub> /0% C <sub>13</sub>	70-75
75% C <sub>12</sub> /25% C <sub>13</sub>	50-55
50% C <sub>12</sub> /50% C <sub>13</sub>	45-50
25% C <sub>12</sub> /75% C <sub>13</sub>	30-35
0% C <sub>12</sub> /100% C <sub>13</sub>	30-35

<sup>a</sup>Preconditioned 0.20M O $\phi$ D[IB]CMPO/  
1.20M TBP mixtures with Nd(NO<sub>3</sub>)<sub>3</sub>  
extracted from 3.0M HNO<sub>3</sub> at 25°C.

<sup>b</sup>Based on Nd/O $\phi$ D[IB]CMPO mole ratio of  
1:3.

<sup>c</sup>The range of numbers means there was  
no third-phase formation at the lower  
percent but at the higher percent.

<sup>d</sup>Heavy organic phase forms with  
3.0M NHO<sub>3</sub>.

loading of TRU and lanthanide salts without formation of a second organic phase. Owing to the reduced loading capacity of this extractant in a diluent of higher molecular weight paraffins, such as the Conoco C<sub>12</sub>-C<sub>14</sub>, the TBP concentration had to be raised slightly, to 1.4M, to increase the concentration of metal that can be contained in a homogeneous organic phase (Table V-7). Extraction studies have indicated that the additional TBP does not greatly influence the extraction of trivalent actinide and lanthanide ions. At very high TBP concentrations, however, the potential does exist for certain fission products to be extracted to a significant extent by the TBP, thus somewhat lowering the selectivity of the solvent.

### 3. Nature and Concentration of Bifunctional Extractant

Of lesser importance than the TBP concentration for third-phase formation is the concentration of the bifunctional extractant itself. Earlier studies showed that for a given TBP concentration, increases in the concentration of O $\phi$ D[IB]CMPO resulted in a decrease in the percentage of theoretical

Table V-7. Loading Capacities of Preconditioned 0.20M O $\phi$ D[IB]CMPO in Conoco C<sub>12</sub>-C<sub>14</sub> Solutions Containing TBP

[TBP], <u>M</u>	% Loading <sup>a</sup>	
	[HNO <sub>3</sub> ] = 1.0 <u>M</u>	[HNO <sub>3</sub> ] = 3.0 <u>M</u>
1.20	50-55	25-30
1.40	~100	50-55

<sup>a</sup>Nd(NO<sub>3</sub>)<sub>3</sub> extracted from HNO<sub>3</sub> solutions at 25°C. Based on Nd/O $\phi$ D[IB]CMPO mole ratio = 1:3.

loading that could be achieved with no third-phase formation (Table V-8). In this case, an increase in the concentration of O $\phi$ D[IB]CMPO from 0.20 to 0.30M, although lowering the percent loading of the extractant solution, resulted in no net change in the amount of metal ion contained in the organic phase. Thus, it appears that, aside from changing the distribution ratios, changes in O $\phi$ D[IB]CMPO concentration have little effect on the total metal extraction under the limited conditions studied.

Table V-8. Loading Capacity of O $\phi$ D[IB]CMPO/1.20M TBP Solutions in Norpar-12<sup>a</sup>

[O $\phi$ D[IB]CMPO], <u>M</u>	% Loading	[Nd] <sub>org</sub> , <u>M</u>
0.20	70-75	0.047-0.050
0.25	55-60	0.046-0.050
0.30	45-50	0.045-0.050

<sup>a</sup>With Nd<sup>3+</sup> from 3.0M HNO<sub>3</sub> at 25°C [HORWITZ-1984].

Examination of the loading of DHDECMP under the same conditions as for O $\phi$ D[IB]CMPO has not been possible owing to the differences in their extracting power. Nevertheless, it qualitatively appears that the DHDECMP/TBP solutions are more prone toward third-phase formation than are solutions of O $\phi$ D[IB]CMPO with TBP. For example, a solution of 0.50M DHDECMP/1.0M TBP can extract only 15-20% of the theoretical amount of Nd(NO<sub>3</sub>)<sub>3</sub> from 3.0M HNO<sub>3</sub> without third-phase formation. This difference in loading between the two bifunctional extractant solutions may be explained by two factors: the much higher concentration of the DHDECMP extractant required to obtain reasonable distribution ratios, and the lower relative ratio of TBP concentration to that of DHDECMP which must be used to keep the total extractant concentration in an acceptable range.



#### 4. Aqueous Phase Nitric Acid Concentration

The concentration of nitric acid in the aqueous phase is another important variable in formation of a third phase. Third-phase formation occurs much less readily at lower nitric acid concentration than at high. A comparison of the data in Table V-6 and Table V-9 shows this effect quite clearly for O $\phi$ D[IB]CMPO. For all the diluents examined, a substantially higher loading could be obtained at the lower acidity.

With DHDECMP, the effect of acidity is even more important. For solutions of 0.4M DHDECMP/1.2M TBP and 0.50M DHDECMP/1.0M TBP in Conoco C<sub>12</sub>-C<sub>14</sub> diluent, heavy organic phases were formed by contacting them with >1.5M HNO<sub>3</sub> solutions at room temperature, with no Nd present. Only at lower acidity could any concentration of metal ion be extracted into the organic phase without third-phase formation.

Table V-9. Effect of Diluent on the Loading Capacity of CMPO-TRUEX Process Solvent at 1.0M HNO<sub>3</sub><sup>a</sup>

Diluent	% Loading
SRP	45-50
Norpar-12	~100
Conoco	50-55
C <sub>10</sub>	100
C <sub>12</sub>	~100
C <sub>13</sub>	55-60
C <sub>14</sub>	30-35
C <sub>16</sub>	<5

<sup>a</sup>0.20M O $\phi$ D[IB]CMPO/1.20M TBP mixtures with Nd<sup>3+</sup> extracted at 25°C.

#### 5. Temperature

It is well known that elevated temperatures reduce the tendency toward third-phase formation. Systems forming two organic phases at 25°C often show only a single organic phase at 40°C; TRUEX process solvents are no exception. For example, a solution of 0.40M DHDECMP/1.20M TBP in Conoco C<sub>12</sub>-C<sub>14</sub> in contact with 6.0M HNO<sub>3</sub> shows no sign of third-phase formation at 40°C, whereas the same solution at 25°C readily forms a third phase with 2.0M acid. (The effect of temperature on distribution ratio was discussed in Section V.A.)

## 6. Other Considerations

In all the systems discussed above, the heavy organic phases formed make up a considerable portion of the volume of the organic phase, frequently in the range of 40 to 60 vol %. In addition, the heavy phases are free flowing, slightly viscous liquids that readily disperse in the lighter organic phase and readily separate from the aqueous phase. They are not solid or semi-solid masses. It is also important to note that the third phase often requires long periods of time to develop (up to several hours). Thus, these TRUEX process solvents can be "supersaturated." The loading figures quoted in this report are for solutions that were allowed to stand a minimum of 4 hours before being examined for phase separation--much higher loadings would have been reported if the solutions had not been allowed to stand for this time.

## 7. Summary of Observations on Third-Phase Formation

Although these results are preliminary, they indicate that an extractant solution that should exhibit acceptable loading characteristics under process constraints can be formulated. The number of factors influencing third-phase formation in these systems is large and the interactions among them are complex. However, several guidelines for operation in a region with a single organic phase seem clear.

- The concentration of TBP should be kept as high as possible within the constraints of viscosity, phase density, and selectivity.
- If necessary, increases in the TBP concentration may be achieved at the expense of the bifunctional extractant concentration if total extractant concentration considerations are important. This approach carries a penalty of reducing the extracting power of the solvent (a third-power effect for TRU and lanthanides) that must be accommodated.
- The aqueous-phase  $\text{HNO}_3$  concentration should be kept as low as is feasible.
- The diluent should be chosen so that the concentrations of the higher molecular weight constituents are kept to a minimum while an adequate flash point is maintained.

TRUEX process flowsheets for DSW and CAW have been designed with the constraint of using Conoco  $\text{C}_{12}$ - $\text{C}_{14}$  as the NPH diluent. If a NPH mixture with lesser amounts of tetradecane were selected, process flexibility would be greatly enhanced. A diluent with a flash point  $>80^\circ\text{C}$  could most easily be prepared by blending Conoco  $\text{C}_{10}$ - $\text{C}_{12}$  and  $\text{C}_{12}$ - $\text{C}_{14}$  in the correct proportions.

## C. Physical Properties of Extractants

### 1. DHDECMP

Until very recently much of the industrially produced DHDECMP was a technical grade chemical with a purity level  $<50\%$  [SCHULZ-1982]. The impurities were a mixture of starting materials and a myriad of unwanted by-products of the synthesis. Many of these compounds have been identified;

many more are still unknown [BAHNER-1977, -1981, FAGERNESS, MCISAAC-1979, NAVRATIL, SCHULZ-1982, SCHROEDER-1980A]. Bray Oil Company (Los Angeles, CA) was, at one time, selling DHDECMP as a 86% pure product [CHAMBERLAIN]. This purity level was attained by distilling the <50% material at high vacuum.

Very recently, Columbia Organic Chemical Company, Inc. (COC) devised an improved synthesis for DHDECMP that results in a nominal purity level of ~86%. This material was obtained directly from the synthesis pot and the purity measured by gas chromatography (GC). Solvent extraction tests of this material at the U.S. DOE Rocky Flats Plant [MUSCATELLO] showed it to contain a large amount of high-molecular-weight, acidic material, which does not allow stripping of actinides and lanthanides by dilute nitric acid. Because acidic compounds are not measurable by GC analysis unless they are first converted to esters, it is more accurate to say that DHDECMP is 86% of the neutral species in this COC product. The ability to strip lanthanides and actinides by dilute nitric acid is not improved by washing of the COC material with solutions of sodium hydroxide or sodium carbonate. This suggests the acidic impurities are of high molecular weight and would be removable by high vacuum distillation, washing with ethylene glycol, or by macroreticular resin treatment. These procedures and others are reviewed by Schulz and Navratil [SCHULZ-1982]. Precipitation of the mercury(II) salt of DHDECMP is the most efficient means found to date for obtaining pure material (>95%) in high yield (~85%) [SCHROEDER-1980B].

Practical industrial parameters such as freezing point, viscosity, and flash points of the CMP-TRUEX process solvent have not been measured. Because the TRUEX process solvents can be envisioned as a modified PUREX process solvent, these parameters can be estimated by simple extrapolation of the properties of DHDECMP and its diluent (30% TBP in NPH). Table V-10 presents the measured and estimated physical parameters (except for aqueous phase solubility, which is treated separately in Section V.D.) of DHDECMP, TBP, Conoco C<sub>12</sub>-C<sub>14</sub>, 30% TBP in Conoco C<sub>12</sub>-C<sub>14</sub>, and the CMP-TRUEX process solvent. In general, the physical parameters for the TRUEX process solvent were calculated by assuming that empirical relationships derived from TBP-diluent mixtures [VANDEGRIFT] also approximate TRUEX process solvents. The addition of DHDECMP was treated as if it had the same unit effect as would adding more TBP to the solution.

## 2. O $\phi$ D[IB]CMPO

Although the synthesis of O $\phi$ D[IB]CMPO is much more difficult than that of DHDECMP, its purification is a relatively simple matter [KAPLAN]. After the synthesis step, the crude product is washed first with 1M HCl and then 1M NaOH solutions; water washes follow each treatment. After the heptane diluent is evaporated under low vacuum, low boiling impurities are removed from the residue in a 1.3 Pa (0.01 torr) vacuum at 205°C. When the flask temperature is raised to 220°C and the systems pressure is lowered to 0.13 Pa (0.001 torr), a ~96% pure O $\phi$ D[IB]CMPO product (determined by GC analysis) is distilled away from the impure residue.

The mercury salt purification procedure [MCISAAC-1981, SCHROEDER-1980B] also works for O $\phi$ D[IB]CMPO. A product of >98% purity (determined by GC analysis) can be obtained by this method.

Table V-10. Estimated Physical Properties of TRUEX Solvents and Their Constituents

Material	Physical Properties <sup>a</sup>					
	Melting Point, °C	Boiling Point, °C	Flash Point, °F (°C)	Specific Gravity	Viscosity, cP	Molecular Weight, g/mol
TBP	-80	289 <sup>b</sup>	295 (146)	0.976	3.39	266
Conoco C <sub>12</sub> -C <sub>14</sub>	-12	190	210 (99)	0.745 <sup>c</sup>	1.78 <sup>c</sup>	187 <sup>d</sup>
30% TBP/Conoco C <sub>12</sub> -C <sub>14</sub>	-	-	226 <sup>e</sup> (108)	0.815 <sup>f</sup>	4.18	-
DHDECMP	Liquid at ambient temperatures	high <sup>h</sup>	high <sup>i</sup>	0.988 <sup>j</sup>	25 <sup>k</sup>	363
OφD[IB]CMPO	44-45 <sup>l</sup>	high <sup>m</sup>	high <sup>n</sup>	1 <sup>o</sup>	10 <sup>4</sup> -10 <sup>5p</sup>	407
0.4M DHDECMP/ 1.2M TBP/Conoco C <sub>12</sub> -C <sub>14</sub> <sup>q</sup>	-	-	231 <sup>r</sup> (111)	0.856 <sup>s</sup>	7 <sup>t</sup>	-
0.2M OφD[IB]CMPO/ 1.4M TBP/Conoco C <sub>12</sub> -C <sub>14</sub> <sup>u</sup>	-	-	236 <sup>r</sup> (114)	0.854 <sup>s</sup>	7 <sup>v</sup>	-

<sup>a</sup>Given at 25°C unless otherwise stipulated. The data provided for TBP and Conoco C<sub>12</sub>-C<sub>14</sub> are measured quantities; other data are estimates. All empirical relationships used to calculate physical parameters were taken from [VANDEGRIFT] and references therein.

<sup>b</sup>Decomposition temperature.

<sup>c</sup>At 60°F (16°C).

<sup>d</sup>Based on average composition: C<sub>13.2</sub>H<sub>28.5</sub>.

<sup>e</sup>Based on the empirical relationship:  $\Delta T = - (T_0^2/2300) \log_{10} M$  where  $\Delta T$  is the increase in flash point;  $T_0$  is the flash point of the pure diluent in degrees Kelvin; and  $M$  is the mole fraction of the diluent [VANDEGRIFT].

<sup>f</sup>Based on the assumption that the density of a resultant solution is equal to the sum of the density of each component multiplied by its volume fraction. This has been proven to be valid for TBP solutions [VANDEGRIFT].

<sup>g</sup>The viscosity of a water-saturated TBP solution can be approximated by the empirical relationship:  $\log_{10} \eta_{mix} = N_{TBP} (1.345 + 0.36 N_{TBP}) + N_{dil} \log_{10} \eta_{dil}$  where  $N_{TBP}$  = volume fraction of TBP;  $\eta_{dil}$  and  $N_{dil}$  are the viscosity and volume fraction of the diluent [VANDEGRIFT].

<sup>h</sup>DHDECMP can not be distilled at atmospheric pressure because it decomposes at a temperature below its boiling point. However, the 86% material was prepared from technical grade DHDECMP by distillation at reduced pressures (0.001 torr,  $\sim 110^\circ\text{C}$  as well as 0.2 torr and  $140^\circ\text{C}$ ) [SCHULZ-1982].

<sup>i</sup>This is an assumption based entirely on its low volatility and its molecular weight being  $\sim 36\%$  greater than TBP.

<sup>j</sup>>99% pure material [SCHROEDER-1980A]. A specific gravity of 0.985 was measured elsewhere for 99.8% pure material [GANSER].

<sup>k</sup>Extrapolated from data at 20, 30, and  $50^\circ\text{C}$ ; the measured viscosities of the >99% material at these three temperatures are 30.8, 19.9, and 9.5 cP, respectively. DHDECMP is a Newtonian fluid [SCHROEDER-1980A].

<sup>l</sup>Although the >99% O $\phi$ D[IB]CMPO is a solid, at a purity level of  $\leq 98\%$ , the material is a viscous oil, which may crystallize on standing for long periods.

<sup>m</sup>A  $\sim 95\%$  product was distilled from the reaction flask at  $\sim 210^\circ\text{C}$  and a vacuum of  $\sim 0.02$  torr in one experiment, at  $\sim 220^\circ\text{C}$  and 0.001 torr in another [KAPLAN].

<sup>n</sup>Based on its low volatility and high molecular weight (53% greater than TBP). Also based on the fact that close analogues, but with lower molecular weights, of this compound have been patented as flame retardant finishing for pile carpeting [HOECHST].

<sup>o</sup>Generally, organophosphorus compounds have densities very close to 1, in the range of 0.97-1.02 g/mL.

<sup>p</sup>Based entirely on the observation that the impure oil pours at a rate that seems lower than that of honey.

(footnotes continued on next page)

<sup>q</sup>Assuming there are no solution effects modifying partial molar volumes of species, this solution is equivalent to 14.7 vol % DHDECMP/32.7 vol % TBP/52.6 vol % NPH and to 17.0 wt % DHDECMP/37.3 wt % TBP/45.8 wt % NPH.

<sup>r</sup>Based on (1) the relationship of footnote e and (2) DHDECMP and  $O\phi D[IB]CMPO$  having the equivalent effect per mole as does TBP.

<sup>s</sup>Based on constant molar volumes of constituents.

<sup>t</sup>Calculated from the relationship given in footnote g, assuming DHDECMP has the same effect per volume fraction as does TBP. Data by McIsaac et al. [MCISAAC-1979] for 30% DHDECMP in diisopropylbenzene (DIPB) show that the calculated approximate viscosity is likely not grossly in error. The viscosities of the water-washed DHDECMP in DIPB are 2.95 cP at 20°C, 2.38 cP at 30°C, and 1.58 cP at 50°C.

<sup>u</sup>Assuming there are no solution effects modifying partial molar volumes of species, this solution is equivalent to 8.1 vol %  $O\phi D[IB]CMPO$ /38.2 vol % TBP/53.7 vol % NPH and to 9.5 wt %  $O\phi D[IB]CMPO$ /43.6 wt % TBP/46.8 wt % NPH.

<sup>v</sup>Calculated from the relationship in footnote g, assuming  $O\phi D[IB]CMPO$  has the same effect per volume fraction as does TBP.

The highest purity O $\phi$ D[IB]CMPO to date was prepared by crystallization from a hexane solution of the crude NaOH-treated product. The crystallized white solid was measured by GC analysis to be >99% pure.

There are no significant differences in the solvent extraction properties of the three purified forms of O $\phi$ D[IB]CMPO at loading levels anticipated in the TRUEX process. For industrial-scale production of the extractant, the purification method employed will likely be chosen based on price and quality control considerations.

Physical parameters (except for aqueous phase solubility, which is treated separately in Section V.D) of O $\phi$ D[IB]CMPO and its TRUEX process solvent are presented in Table V-10. Very little physical information is available on this extractant and its solutions; therefore, most of the information is extrapolated by methods explained in table footnotes.

#### D. Aqueous Phase Solubilities and Partitioning of Extractants

##### 1. DHDECMP

The solubility of DHDECMP and its partition between organic and aqueous phases is similar to that of TBP. Table V-11 records solubility and partitioning data of several researchers and, in some instances, compares these data to those of TBP. The data of Table V-11 indicate that DHDECMP has a lower solubility in aqueous phases than some of its accompanying impurities.

The partitioning of TBP between an organic solvent and an aqueous phase is highly dependent on the organic diluent [VANDEGRIFT]. As might be expected, the stronger the interaction between TBP and its diluent, the lower the fraction of TBP that partitions to the aqueous phase. The association of TBP and DHDECMP in the NPH diluent should lead to a lower loss of both species to the aqueous phase than would be expected by the data presented in Table V-11.

##### 2. O $\phi$ D[IB]CMPO

Results of preliminary measurements on the partitioning of CMPO compounds and TBP between mixed CMPO/TBP solvents and aqueous phases are listed in Table V-12.

Although the bulk of the data was obtained with (2-ethylhexyl) (phenyl)-N,N-diisobutylcarbamoylmethylphosphine oxide, the trends are clear. Increased temperature increases the distribution ratio of TBP and CMPO extractants, and increasing the acidity of the aqueous phase decreases the distribution ratios of the extractants. Higher temperatures lower the loss of extractants to the aqueous phase; higher acidities increase extractant loss.

Table V-11. Aqueous Phase Solubility and Partitioning of DHDECMP

Organic Phase (% Purity)	Aqueous Phase	Temp., °C	[DHDECMP], <sup>a</sup> g/L	Ref.
Undiluted (86%) <sup>b</sup>	0.1M HNO <sub>3</sub>	23	0.5 (0.4-0.5)	[SCHULZ-1977A, -B]
1M of (86%) in DIPB <sup>c,d</sup>	3M HNO <sub>3</sub>	25	0.24	[KATZ]
30 vol % of (99%) in DIPB	3M HNO <sub>3</sub>	23	0.21	[MCISAAC-1979]
30 vol % of (99%) in DIPB	4M HNO <sub>3</sub>	23	0.20	[MCISAAC-1979]
30 vol % of (99%) in DIPB	0.015M HNO <sub>3</sub> - 0.05M HAN	23	0.17	[MCISAAC-1979]
30 vol % of (99%) in DIPB	0.5M Na <sub>2</sub> CO <sub>3</sub>	23	0.044	[MCISAAC-1979]
33 vol % of (85%) in IPB <sup>e</sup>	0.1M HNO <sub>3</sub>	--	1.93	[GANSER]
33 vol % of (85%) in IPB	3M HNO <sub>3</sub>	--	1.62	[GANSER]
33 vol % of (99.6%) in IPB	0.1M HNO <sub>3</sub>	--	0.15	[GANSER]
33 vol % of (99.6%) in IPB	3M HNO <sub>3</sub>	--	0.28	[GANSER]
Undiluted (86%) <sup>b</sup>	H <sub>2</sub> O	--	2.2 (1.0)	[HAGAN]
Undiluted (86%)	1M HNO <sub>3</sub>	--	2.4 (0.5)	[HAGAN]
Undiluted (86%)	4M HNO <sub>3</sub>	--	3.6 (0.3)	[HAGAN]
Undiluted (86%)	7M HNO <sub>3</sub>	--	2.1 (0.3)	[HAGAN]
Undiluted (86%)	10M HNO <sub>3</sub>	--	4.3 (0.7)	[HAGAN]

<sup>a</sup>For comparison, the solubility of TBP measured in the same manner by the same researchers is in parentheses.

<sup>b</sup>Since it was not specified, this purity was assumed.

<sup>c</sup>1M DHDECMP as ~36 vol %.

<sup>d</sup>DIPB = diisopropyl benzene.

<sup>e</sup>IPB = isopropyl benzene.



Table V-12. Partitioning of CMPO Extractants under Various Conditions

Organic Solvent	Aqueous Phase	Temperature, °C	Distribution Ratio		Aqueous Phase Concentrations, M (mg/L)	
			CMPO	TBP	CMPO	TBP
0.2M O $\phi$ D[IB]CMPO/ 1.2M TBP/Norpar 12 <sup>a</sup>	1M HNO <sub>3</sub>	25	6.7x10 <sup>3</sup>	1.6x10 <sup>3</sup>	3.0x10 <sup>-5</sup> (12)	7.6x10 <sup>-4</sup> (200)
0.2M EH $\phi$ D[IB]CMPO/ 1.2M TBP/Norpar 12	1M HNO <sub>3</sub>	25	6.1x10 <sup>3</sup>	1.3x10 <sup>3</sup>	3.3x10 <sup>-5</sup> (13)	9.1x10 <sup>-4</sup> (240)
0.2M EH $\phi$ D[IB]CMPO/ 1.2M TBP/Norpar 12	1M HNO <sub>3</sub>	50	1.0x10 <sup>4</sup>	1.9x10 <sup>3</sup>	2.0x10 <sup>-5</sup> (8.1)	6.6x10 <sup>-4</sup> (180)
0.2M EH $\phi$ D[IB]CMPO/ 1.2M TBP/Norpar 12	0.25M Na <sub>2</sub> CO <sub>3</sub>	25	2.0x10 <sup>4</sup>	2.8x10 <sup>3</sup>	1.0x10 <sup>-5</sup> (4.1)	4.3x10 <sup>-4</sup> (110)
0.2M EH $\phi$ D[IB]CMPO/ Isopar 12 <sup>c</sup>	1M HNO <sub>3</sub>	25	1.3x10 <sup>3</sup>	-	1.5x10 <sup>-4</sup> (61)	-
1.2M TBP/ Hyframe 12 <sup>e</sup>	2M HNO <sub>3</sub>	21	-	1.5x10 <sup>3</sup> <sup>d</sup>	-	7.9x10 <sup>-4</sup> <sup>d</sup> (210)

<sup>a</sup>Norpar 12 is a mixture of normal aliphatic hydrocarbons with an average carbon chain length of 11.4.

E. Chemical and Radiolytic Degradation of TRUEX Process Extractants and Solvent Cleanup

1. DHDECMP

Studies of the hydrolysis and radiolysis of DHDECMP and its analogues have been reported by six groups of researchers: Schulz et al. [SCHULZ-1974, -1975, -1977A, -1977B, -1982]; McIsaac et al. [SCHULZ-1975, -1977A, -1977B, MCISAAC-1976, -1980, BAKER]; Shoun et al. [SHOUN, BAHNER-1981]; Katz and Bond [KATZ]; Kazanjian and Killion [KAZANJIAN]; and Ganser [GANSER]. The consensus of these studies is that the stability of DHDECMP to both hydrolysis and radiolysis is slightly less than that of TBP. (In a related study, Nowak et al. found another phosphonate, diamylamylphosphonate, to show considerably less hydrolytic and radiolytic stability than TBP [NOWAK].) Hydrolysis and radiolysis are manifested in DHDECMP solutions as they are by TBP solutions: acidic products are formed, which do not allow the stripping of actinides and lanthanides by dilute nitric acid.

The most ambitious effort to study hydrolysis and radiolysis of DHDECMP was performed by Bahner et al. [BAHNER-1981], who found a large variety of hydrolysis/radiolysis products that showed attack of DHDECMP at both the phosphoryl and carbamoyl ends of the molecule. The formation of CO gas and free amines during radiolysis points to a decarbonylation reaction as being important. Acidic materials whose elemental analysis revealed the presence of nitrogen were also present.

Although results of various studies show differences in degree, washing with 0.35-1.0M Na<sub>2</sub>CO<sub>3</sub> or NaOH solutions seems to remove a large portion of these acidic degradation products.

2. O $\phi$ D[IB]CMPO

There is very little experimental information on the radiolytic and hydrolytic decomposition of O $\phi$ D[IB]CMPO. The scant data that have been obtained lead to the conclusion that the decomposition of the impurities associated with O $\phi$ D[IB]CMPO may be of more importance than the decomposition of the extractant itself. These impurities and their decomposition products, the problems they cause in the solvent extraction process, and methods to remove them are discussed in detail below. The following is a prediction of hydrolytic and radiolytic stability of CMPO based on literature analogies.

Two important differences exist between the chemical structures of DHDECMP and O $\phi$ D[IB]CMPO. The first is that the CMPO compound has three phosphorus-carbon bonds and the CMP compound has only one carbon-phosphorus bond and two carbon-oxygen-phosphorus bonds (ester linkages). Carbon-phosphorus bonds are much stronger than phosphorus ester linkages and much more resistant to nucleophilic attack of the phosphorus atom and subsequent hydrolysis [KIRBY]. The second important difference between O $\phi$ D[IB]CMPO and DHDECMP is the inclusion of the aromatic group in the structure of O $\phi$ D[IB]CMPO. It has been generally accepted that dissolving an extractant, such as TBP, in an

aromatic diluent increases resistance of TBP to radiolytic damage [VANDEGRIFT]. This is explained by the aromatic ring acting as an energy sink and thus diminishing the effects of energy pulses of the incoming radiation. In a report dealing with the radiation stability of materials used in nuclear plants [BRUCE], an approximate order of radiation stability for polymers was given as:

substituted aromatics > aromatics > alkanes >

ethers > alcohols > esters > ketones.

Based on these facts, O $\phi$ D[IB]CMPO would be predicted to be a great deal more resistant to radiolytic and hydrolytic damage than DHDECMP, especially at the phosphoryl end of the molecule. This aromatic group may also help to protect the carbamoyl group from radiolytic damage. The radiolysis of the solvent modifier, TBP, should also be beneficially lowered by the presence of O $\phi$ D[IB]CMPO.

Preliminary measurements of the radiation stability of CMPO indicate that absorbed doses of 10 Wh/L cause only minor degradation. However, much more extensive studies will be required before definitive comparisons between TRUEX and PUREX process solvents can be made. In all likelihood, radiolytic degradation will parallel hydrolytic degradation, resulting in TBP degradation products dominating the impurities in the TRUEX solvent.

Since the CMPO-TRUEX process solvent is essentially PUREX process solvent modified by the addition of 8.15 wt % O $\phi$ D[IB]CMPO, the usual radiolytic and hydrolytic degradation products that are produced in PUREX process operation will also be produced in the TRUEX process. In addition, any degradation products produced either from the O $\phi$ D[IB]CMPO itself or from its impurities will also be present. The primary substances that have a deleterious effect in both PUREX and TRUEX process operations are acidic compounds. The presence of acidic compounds in neutral extractants prevents efficient stripping with dilute aqueous HNO<sub>3</sub> and frequently results in the formation of insoluble interfacial crud with certain fission products, e.g., zirconium. A basic difference between TBP and O $\phi$ D[IB]CMPO is in the type of acidic compounds that can be produced from each of the two extractants by radiolytic and hydrolytic processes. In the case of TBP, dialkyl- and monoalkylphosphoric acids are produced, whereas with O $\phi$ D[IB]CMPO, dialkyl- and alkyl(phenyl)phosphinic acids\* are the primary degradation products. In the case of O $\phi$ D[IB]CMPO, the acidic compounds would be produced almost entirely from impurities rather than directly from that extractant itself. (A carboxylic acid extractant from O $\phi$ D[IB]CMPO can be produced by hydrolysis of the amide moiety, but the resultant acid is a very weak extractant of no consequence; furthermore, such a compound rapidly decarboxylates to a phosphine oxide, which also is of no consequence to the performance of the TRUEX process.)

---

\*These compounds have the general formula

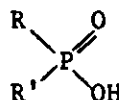

, where R is an aliphatic carbon chain and R' is an aliphatic carbon chain or a phenyl group.

It is important to note that alkylphosphoric acids are much more powerful extractants than alkylphosphinic acids. In the case of the dioctyl derivatives,  $D_{Am}$  is  $10^4$  times greater for the phosphoric acid than for the corresponding phosphinic acid [PEPPARD, MASON]. Since the TBP concentration in TRUEX solvent is seven times higher than the CMPO concentration, the generation of dialkylphosphoric acids from TBP is far more important than any degradation products produced from CMPO. Because of their interfacial activity and the low aqueous solubility of their sodium salts, however, high molecular weight alkylphosphinic acids can interfere with phase separation and conventional  $Na_2CO_3$  solvent cleanup processes.

Table V-13 lists the possible impurities in  $O\phi D[IB]CMPO$ , their estimated concentrations, and potential hydrolysis products (if any). Only three compounds listed in Table V-13 appear to present any problem: diphenylphosphinic acid [ $\phi_2P(O)OH$ ], octyl(phenyl)phosphinic acid [ $C_8H_{17}(\phi)P(O)OH$ ], and dioctylphosphinic acid [ $(C_8H_{17})_2P(O)OH$ ]. These three phosphinic acids, or their sodium salts, are not appreciably soluble in water and, thus, will likely not be efficiently removed by  $Na_2CO_3$  scrubbing. Furthermore, their sodium salts can cause emulsion problems, especially in the case of  $(C_8H_{17})_2P(O)OH$  and  $C_8H_{17}(\phi)P(O)OH$ . The presence of  $(C_8H_{17})_2P(O)OH$  and its precursor, dioctylphosphine oxide, can easily be eliminated in the synthesis of  $O\phi D[IB]CMPO$ . Dioctylphosphine oxide can also be removed from  $O\phi D[IB]CMPO$  by crystallization from an unseeded hexane solution of  $O\phi D[IB]CMPO$ . The concentration of dioctylphosphine oxide in the commercial  $O\phi D[IB]CMPO$  used for the batch countercurrent experiment described in Appendix B was ~4% as determined by  $^{31}P$  nuclear magnetic resonance (NMR).

All three of the phosphinic acids listed in Table V-13 can be removed from TRUEX process solvent by means of a macroporous strong base anion exchange resin, such as Amberlyst™ A-26 resin [SCHULZ-1971, -1972]. The CMPO-TRUEX process solvent is first equilibrated with 1M  $HNO_3$  and then with water to a  $pH > 2$ . This procedure ensures that the phosphinic acids are in the acidic form. In addition, dibutylphosphoric acid formed from hydrolysis of TBP is also removed by the resin [SCHULZ-1971, -1972]. Although extensive tests on used CMPO-TRUEX process solvent have not been performed, the use of the anion exchange method appears ideal for solvent cleanup. In principle, the currently employed solvent cleanup procedures used for PUREX process solvent are applicable to the TRUEX process solvent; however, the higher molecular weight of the acidic degradation products arising from the bifunctional extractant may reduce the efficiency of the sodium carbonate and hydroxide washes.

#### F. Potential Suppliers and Estimated Unit Prices of Extractants

Four potential suppliers of bulk quantities of DHDECMP and/or  $O\phi D[IB]CMPO$  were contacted for estimates of their ability to supply these extractants in the quantities and purities needed for startup and solvent makeup during TRUEX operation and for the cost per pound of the extractants at that supply level. Listed in Table V-14 are these companies and the extractant(s) they are currently interested in supplying.

Table V-13. Possible Impurities in Crystallized O $\phi$ D[IB]CMPO

Compound	Concentration, wt %	Comments
ClCH <sub>2</sub> C(O)N[CH <sub>2</sub> CH(CH <sub>3</sub> ) <sub>2</sub> ] <sub>2</sub>	<0.1	Unreacted starting material.
HOCH <sub>2</sub> C(O)N[CH <sub>2</sub> CH(CH <sub>3</sub> ) <sub>2</sub> ] <sub>2</sub>	<0.1	Formed by hydrolysis of ClCH <sub>2</sub> C(O)N[CH <sub>2</sub> CH(CH <sub>3</sub> ) <sub>2</sub> ] <sub>2</sub> . Neutral species that should easily scrub out with base.
C <sub>2</sub> H <sub>5</sub> O( $\phi$ )P(O)CH <sub>2</sub> C(O)N[CH <sub>2</sub> CH(CH <sub>3</sub> ) <sub>2</sub> ] <sub>2</sub>	0.6	Result of incomplete Grignard reaction. Will hydrolyze to HO( $\phi$ )P(O)CH <sub>2</sub> C(O)N[CH <sub>2</sub> CH(CH <sub>3</sub> ) <sub>2</sub> ] <sub>2</sub>
HO( $\phi$ )P(O)CH <sub>2</sub> C(O)N[CH <sub>2</sub> CH(CH <sub>3</sub> ) <sub>2</sub> ] <sub>2</sub>	Unknown	Should scrub out with base.
H( $\phi$ )P(O)OC <sub>2</sub> H <sub>5</sub>	<0.1	Unreacted starting material. Will hydrolyze to H( $\phi$ )P(O)OH but should scrub out with base.
$\phi$ <sub>2</sub> P(O)OC <sub>2</sub> H <sub>5</sub>	<0.1	Impurity in H( $\phi$ )P(O)OC <sub>2</sub> H <sub>5</sub> . Will hydrolyze to $\phi$ <sub>2</sub> P(O)OH.
$\phi$ <sub>2</sub> P(O)OH	<0.1	
$\phi$ P(O)(C <sub>8</sub> H <sub>17</sub> ) <sub>2</sub>	<0.1	Neutral extractant of no conse- quence.
$\phi$ <sub>2</sub> P(O)C <sub>8</sub> H <sub>17</sub>	<0.1	Neutral extractant of no conse- quence.
C <sub>8</sub> H <sub>17</sub> ( $\phi$ )P(O)H	0.3	Will oxidize to C <sub>8</sub> H <sub>17</sub> ( $\phi$ )P(O)OH.
(C <sub>8</sub> H <sub>17</sub> ) <sub>2</sub> P(O)H	0.25-4	Will oxidize to (C <sub>8</sub> H <sub>17</sub> ) <sub>2</sub> P(O)OH.

Table V-14. Potential Suppliers of DHDECMP and/or O $\phi$ D[IB]CMPO<sup>a</sup>

Supplier	Extractant	Comments
M&T Chemicals Bio and Fine Chemicals Division Rahway, NJ 07065 (201) 499-0200	O $\phi$ D[IB]CMPO	Have prepared kg amounts of this compound using the synthesis of Kaplan et al. and have tested various means of purification. Are testing other synthetic routes.
Columbia Organic Chemical Company, Inc. Camden, SC 29020 (800) 845-2202	DHDECMP O $\phi$ D[IB]CMPO	Have prepared impure (~50%) DHDECMP for years (formerly as Wateree Chem) and have developed a new synthesis route to prepare 86% material. This material must, however, still be purified from high boiling, acidic materials.
Industrial Chemicals Group Mobil Chemical Company Richmond, VA 23261 (804) 798-4291	DHDECMP	They had previously been contacted by Rocky Flats Plant to produce DHDECMP for their operation. Their interest has waned because the potential market does not appear large enough.
Geochem Minerals & Chemicals, Inc. Marysville, WA 98270 (206) 653-5661	DHDECMP O $\phi$ D[IB]CMPO	Geochem has no experience in manufacturing these extractants or in chemicals of this type.

<sup>a</sup>Bray Oil Company, a past supplier of DHDECMP, was contacted by Rocky Flats Plant (RFP) personnel about producing a 100-gal lot of DHDECMP. They were not especially interested in doing this and quoted a price of 3-4 times that of Columbia Organic Chemicals (personal communication with A. Muscatello, RFP).

Columbia Organic Chemical Company appears to be the most stable and reliable supplier of DHDECMP. This company has supplied this chemical for many years as a <50% technical grade material (as Wateree Chemical Company) and recently developed an improved synthesis to prepare 86% material for a price less than they were charging for the <50% grade chemical. This improved material, however, still contains high molecular weight, acidic materials that must be removed to enable the use of dilute HNO<sub>3</sub> strips of actinides and lanthanides. Columbia Organic is currently investigating means to further purify the DHDECMP product so it is acceptable for TRUEX processing.

Columbia Organic is an expanding company that has progressed during its forty years of existence from a supplier of industrial cleaners and solvents to a supplier and manufacturer of ~4,500 cataloged chemicals; many thousands more have been supplied on a custom basis. Annual sales increased from \$775,000 in 1977 to \$1.4 million in 1983 [COC].

M&T Chemicals appears to be the best source for a stable and reliable supply of O $\phi$ D[IB]CMPO. It has produced kilogram amounts of ~95% pure material by following the synthesis developed at ANL [KAPLAN]. Purified material can be obtained by either high-vacuum distillation or by crystallization of the product from a paraffin solution. After testing these purification methods in its laboratories, M&T believes crystallization is more practical for large-scale production.

Chemists at M&T are also studying the possibility of alternative syntheses that will be more cost effective for industrial-scale production. Because M&T produces the requisite starting materials for synthesis of O $\phi$ D[IB]CMPO, it is intensely interested in seeing markets open for use of this chemical.

M&T is a \$270 million corporation wholly owned by Elf Aquitaine, a \$17 billion diversified oil, gas, and natural resource corporation headquartered in Paris, France. Since 1941, the French government has owned greater than 50% of the shares of Elf Aquitaine, 67% since 1976. Elf Aquitaine was the 23rd largest company in the world in terms of revenues and 14th in terms of net earnings at the end of 1980.

The methods and reagents for the synthesis of O $\phi$ D[IB]CMPO, the relatively small volume of its demand, and its chemical composition make this extractant a perfect product for M&T's Bio and Fine Chemicals Division, which according to M&T is "a pioneering developer and leading manufacturer of organometallic chemicals and polymers based on tin, phosphorus, and other metals....With 30 years commercial experience, M&T is a world leader in producing Grignard-derived chemicals [M&T]."

Both potential suppliers responded to a            degree to requests for pricing information. According to COC, it is presently able to supply the first 100-gal lot of DHDECMP within 90 days of placement of the order and believes that the 90-day delivery time can be greatly shortened after the first batch is made. This first batch would be priced at \$400.00/gallon. This price will be reexamined and perhaps lowered after the first 100-gallon batch is prepared. (This price does not include further purification steps to remove the acidic impurities from the >86% material. These steps will certainly be necessary to prepare a useful extractant and will significantly increase its unit price.)

M&T Chemicals is, at this time, still in the process of estimating the costs of providing O $\phi$ D[IB]CMPO. Its initial estimate, based on synthesizing kilogram quantities of this material and studying various methods of purifying it, was ~\$300/lb in 1000 lb lots of the >96% pure extractant. Because the preparation and purification of this material are very labor intensive, there would be a great saving in buying larger quantities; e.g., purchasing a 5,000-10,000 lb lot would decrease the unit price by half. There would be no problem in supplying this extractant in greater amounts; M&T's production capacity is very flexible.

#### G. Evaluation of Extractant Inventory and Loss

The extractant inventory is determined by how long the plant must be able to operate without recycling the organic phase. For purposes of this evaluation, it is assumed that one needs enough solvent for 8 hours of operation

and that  $10^7$  L of aqueous feed are to be processed in 5 years at 72% plant efficiency. This gives a solvent volume, 1700 L, that is much more than the minimum required solvent inventory,  $\sim 100$  L for pulsed columns and  $\sim 25$  L for centrifugal contactors. (The B Plant at the Rockwell Hanford Organization, originally designed for the bismuth phosphate process, is much larger than required for the proposed TRUEX process and currently runs with a solvent inventory of 15,000 L.) Extractant is lost because of both solubility losses and dispersed phase losses. Both TRUEX process extractants are slightly soluble in aqueous solutions. This loss of dissolved extractant is the minimum possible value for extractant loss. Additional extractant losses occur because fine droplets of organic phase are entrained in the various aqueous effluents. For purposes of this evaluation, 0.04 vol % of the organic phase is assumed to be entrained in each aqueous effluent. It is expected that, during the course of process development, the range of process conditions under which this low entrainment level could be maintained would be determined.

The results, summarized in Table V-15, show that, although the inventory cost for DHDECMP is less than that for  $O\phi D[IB]CMPO$ , more DHDECMP is lost during processing, making it less economically attractive than  $O\phi D[IB]CMPO$ . Table V-15 shows the major cause of processing loss of  $O\phi D[IB]CMPO$  to be organic phase droplets entrained in the aqueous phase. On a percentage basis, the dispersion losses are 76% for  $O\phi D[IB]CMPO$  losses and 24% for DHDECMP losses. Thus, there is an incentive in both cases, but especially for the  $O\phi D[IB]CMPO$ , which is more expensive, to reduce the volume fraction of organic phase dispersed in the aqueous effluents.

#### H. Process Equipment for Solvent Extraction

Process equipment for solvent extraction falls into one of two classes, continuous (differential) contact equipment and stagewise contact equipment (mixer-settler) [TREYBAL]. For nuclear fuel reprocessing where reduced equipment size is important, continuous-contact equipment that actively agitates the liquid-liquid dispersion has been very useful. Pulsed columns, such as those in use at Hanford, represent a good example of agitated continuous contact equipment. Because of their compact size, centrifugal contactors, which include both mixing and centrifugal-settling zones in each stage, have become a viable alternative to pulsed columns. This is especially true for annular centrifugal contactors, for which a well-documented design basis has been developed [BURRIS].

Pulsed columns and annular centrifugal contactors are compared in Table V-16. Both units can and have been adapted for remote maintenance, and both units have been used as the extraction/scrub unit (A-Bank) of the PUREX process with many years of successful process operation. Compared with the centrifugal contactor, the pulsed column has lower capital cost. However, the much greater building height required for the pulsed column can result in an overall lower cost for the centrifugal contactor when the cost of the unit plus the cost of the building are considered together.

For direct comparison of continuous-contact pulsed columns with stagewise centrifugal contactors, one must know the relationship between the number of extraction stages ( $n_e$ ) in the contactor and the number of transfer units



Table V-15. Evaluation of Extractant Loss<sup>a</sup>

	DHDECMP	O $\phi$ D[IB]CMPO
Solubility in aqueous phase, vppm	200	10
Volume of organic phase that is extractant, %	16	8
Extractant dispersed in aqueous phase, vppm	64	32
Aqueous effluent volume per volume of aqueous feed, volume fraction	2.0	1.8
Solvent inventory, <sup>b</sup> L	1,700	1,700
Extractant inventory, L	270	140
Extractant loss, L/yr	1,100	150
Estimated extractant cost, \$/L	200	600
Cost of extractant inventory, \$	54,000	82,000
Cost of lost extractant, \$/yr	220,000	91,000

<sup>a</sup>Based on  $10^7$  L of aqueous feed being processed in 5 years at 72% plant efficiency so that the aqueous feed rate is 5.3 L/min when the plant is in operation. Also based on 0.04 vol % of organic phase in the aqueous effluents. (The value of 0.04 vol % is an estimate based on observations that systems that perform well usually have <0.1 vol % of organic phase entrained in the aqueous effluent.)

<sup>b</sup>Based on having enough solvent inventory for 8 hours of plant operation before reusing any solvent at a solvent feed rate of 3.53 L/min. Actual solvent inventory in pulsed columns would be about 100 L; in annular centrifugal contactors, about 25 L.

(NTU) in the pulsed column. For the conditions encountered in the extraction section with DSW and CAW feeds, i.e., dilute concentrations of metal ions, the equation given in footnote b of Table V-17 applies. Results for the four cases discussed in this report are shown in Table V-17. If the height of an equivalent theoretical stage (H.E.T.S.) is known for the pulsed column, then the number of extraction stages ( $n_e$ ) can be used directly to get the height of the extraction zone. Normally, NTU is used with the height of a transfer unit (HTU) to calculate the extraction zone height because H.E.T.S. varies more widely with changes in operating conditions than does HTU.

Table V-16. Comparison of Pulsed Columns and Annular Centrifugal Contactors for Solvent Extraction

Favorable Operating Characteristics	Pulsed Columns <sup>a</sup>	Annular Centrifugal Contactors <sup>a</sup>
Low residence time <sup>b</sup>	-	+
Stable operation with changing flows and flow ratios <sup>c</sup>	-	+
Accommodation of all O/A ratios	-	+
Good operation at reduce flows	-	+
Minimum floor space	+	-
Minimum vertical height	-	+
Minimum capital cost <sup>d</sup>	+	-
Easy to add more stages	-	+
Minimum energy use	+	-
Maintenance of concentration gradient in the unit during short periods of downtime	-	+
Easy to introduce or withdraw side streams of liquid	-	+
Flow channeling not possible	-	+

<sup>a</sup>The plus (+) or minus (-) designations shown here are relative weightings of pulsed columns with annular centrifugal contactors. For example, while low residence time is better for annular centrifugal contactors than for pulsed columns, it is better for pulsed columns than for either packed columns or gravity mixer-settlers.

<sup>b</sup>Low residence time reduces radiolysis of organic phase and allows rapid startup and shutdown of the unit.

<sup>c</sup>For stable operation as defined here, the number of the stages in the unit should not change as flow rates and flow ratios change. In addition, the extraction efficiency of each stage should remain high.

<sup>d</sup>For a unit with a given throughput, the capital cost of the annular centrifugal contactor may be about 2.5 times that of the pulsed column.

Table V-17. Number of Transfer Units (NTU) Required for Americium Extraction

Feed	Extractant	O/A Flow Ratio (R)	Distribution Coefficient (D)	Extraction Factor (RD)	Number of Stages <sup>a</sup> (n <sub>e</sub> )	NTU <sup>b</sup>
DSW	OφD[IB]CMPO	0.5	12	6	7	15.1
CAW	OφD[IB]CMPO	0.5	14.4	7.2	6	13.8
DSW <sup>c</sup>	DHDECMP	0.5	4	2	14	19.4
CAW	DHDECMP	0.5	4	2	14	19.4

<sup>a</sup>Based on an americium concentration in the aqueous raffinate such that the raffinate will have <100nCi/g of solidified raffinate as metal oxides.

$${}^b\text{NTU} = \begin{cases} n_e, & \text{RD} = 1 \\ \frac{n_e \ln(\text{RD})}{1 - (1/\text{RD})}, & \text{RD} \neq 1 \end{cases}$$

as given in [TREYBAL] is appropriate for the processing conditions that exist here.

<sup>c</sup>Modified to a composition close to that of CAW by the addition of Al(NO<sub>3</sub>)<sub>3</sub>.

Table V-17 shows how either pulsed columns or annular centrifugal contactors can be used to carry out the flowsheets shown in this report. The extraction unit need only be designed with the appropriate number of transfer units (NTU) or number of stages (N<sub>e</sub>), respectively. As indicated by Table V-16, annular centrifugal contactors offer many advantages over pulsed columns for process flexibility and reliability, ease of operation, and short residence time. Thus, when buying new equipment, the purchase of annular centrifugal contactors is recommended.

### I. Process Safety

Because TRUEX process solvents are modified Purex solvents, safety concerns and practices for PUREX process operation are important also for TRUEX process operation. The major modification of PUREX process solvent in preparing a TRUEX process solvent is, of course, the addition of either DHDECMP or OφD[IB]CMPO.

Because both compounds have low volatility and, therefore, are believed to have high flash points and because their solutions have estimated flash points above those of 30% TBP/NPH (see Table V-10), the only real safety concern in their use is toxicity. An Ames test has been performed on DHDECMP and been reported by Schroeder et al. [MCISAAC-1979, SCHROEDER-1980A]. A quote from SCHROEDER-1980A serves well in explaining the significance of this test:

The Toxic Substances Control Act (TSCA) has made the toxicity of a compound an important physical property. Increased use by us and other researchers throughout the country initiated the mutagenic study as a first step in determining the toxic properties of DHDECMP. Results of the mutagenic study, with and without the microsomal addition, were negative for all strains of Salmonella. Since there is a 90% chance that compounds found mutagenic by the Ames test will cause malignant tumors [McCANN], the test indirectly screens for carcinogenicity. Caution must be taken from inferring too much from these tests. No single in vitro test is sufficient to clear or indict a compound. In addition, the test says nothing about the compounds acute toxicity.

No such studies have been performed on O $\phi$ D[IB]CMPO.

## VI. RECOMMENDATIONS FOR ADDITIONAL R&amp;D

The TRUEX extraction system using  $O_{\phi}D[IB]CMPO$  shows great promise. It has great flexibility and can be used to extract TRU from a wide variety of  $HNO_3$  solutions. The following unknown or poorly known system parameters must be investigated to complete development of the TRUEX process:

- Radiolysis and hydrolysis of the solvent under realistic process conditions.
- Physical characteristics of  $O_{\phi}D[IB]CMPO$  and  $DHDECMP$  and their TRUEX solvents that are important to the process, to solvent makeup, and to quality control analyses.
- Effects of possible variations in the feed composition on the process. Possible modifications of process conditions to counteract these variations in the feed composition. Development of process control procedures and of analytical methods to test feed and solvent compositions.
- Solvent losses due to aqueous phase solubility and entrainment. (The extent and consequences of disproportionate losses of the extractant and TBP are an important variable; means to analyze for both species in the solvent and to correct compositional changes must be studied.)
- Effects of temperature on third-phase formation and distribution ratios under process conditions.
- Improvement of neptunium extraction and stripping.
- Improvement of stripping efficiency for all TRU elements and technetium.
- Effectiveness of solvent washes for the removal of acidic decomposition products. (If conventional  $Na_2CO_3$  or  $NaOH$  strips are not sufficient, then methods that will work, e.g., the use of macroporous anion exchange resins, need to be devised.)
- Elimination of the split scrub for the  $CMPO$ -TRUEX flowsheets.
- Design of reference flowsheets for other potential feeds based on measuring batch-distribution ratio data for synthetic and actual feed solutions.
- More countercurrent tests of various TRUEX process flowsheets with both synthetic and actual feed solutions. (Tests should be run initially on laboratory equipment, e.g., mini-centrifugal contactors, followed by tests on engineering-scale equipment.)

## ACKNOWLEDGMENTS

The funding for developing conceptual flowsheets for TRU removal from DSW and CAW was provided by Rockwell Hanford Operations. Rockwell Hanford personnel who assisted us by providing information and guidance on CAW and DSW composition and on typical plant-scale solvent extraction process parameters are W. W. Schulz, R. A. Watrous, and J. D. Kaser.

The majority of the experimental data in the report was obtained under research funded to the Chemistry Division authors by DOE Basic Energy Sciences.

The authors would like to acknowledge the help of P. R. Danesi, Chemistry Division, ANL, and R. Chiarizia, Chemistry Division, ENEA-Casaccia, Rome, Italy, in performing the laboratory batch countercurrent experiments and the efforts of E. L. Callis, A. M. Essling, and E. A. Huff, Analytical Chemistry Laboratory, ANL, in providing analytical data at the fast pace required for this effort.

## REFERENCES

## BAHNER-1977

C. T. Bahner, R. R. Shoun, W. J. McDowell, Impurities That Cause Difficulty in Stripping Actinides from Commercial Tetraalkylcarbamoylmethylphosphonates, Oak Ridge National Laboratory, ORNL/TM-5878 (1977).

## BAHNER-1981

C. T. Bahner, R. R. Shoun, and W. J. McDowell, Effects of Radiation, Acid, and Base on the Extractant Dihexyl-[(Diethylcarbamoyl)methyl]-phosphonate, Oak Ridge National Laboratory, ORNL/TM-7494 (November 1981).

## BAKER

J. D. Baker, L. D. McIsaac, J. F. Krupa, D. H. Meikrantz, and N. C. Schroeder, Experimental Mixer Settler Actinide Partitioning from ICP Acidic Wastes, Idaho Chemical Processing Plant, ICP-1181 Rev. (August 1979).

## BRADLEY

R. F. Bradley and A. J. Hill, Jr., Chemical Dissolving of Sludge from a High Level Waste Tank at the Savannah River Plant, Savannah River Laboratory, DP-1471 (November 1977).

## BRUCE

M. B. Bruce and M. V. Davis, Radiation Effects on Organic Materials in Nuclear Plants, Electric Power Research Institute, EPRI NP-2129 (November 1981).

## BURRIS

L. Burris et al., Chemical Engineering Division Annual Technical Report, 1981, Argonne National Laboratory, ANL-82-23 (1982).

## CHAMBERLAIN

D. B. Chamberlain, M. R. Maxey, L. D. McIsaac, and G. J. McManus, Removal of Actinides from Nuclear Fuel Reprocessing Waste using an Organophosphorus Extractant, Exxon Nuclear Idaho Company, Inc., ENICO-1053 (August 1980).

## COC

This discussion is based on literature provided by Columbia Organic Chemical Company.

## FAGERNESS

P. Fagerness and T. Elwood, work presented in Idaho Chemical Programs Annual Technical Report Fiscal Year 1976, Idaho Chemical Processing Plant, ICP-1102 (June 1977).

## GANSER

B. Ganser, Analysis and Recovery Methods for Americium in the Nuclear Fuel Cycle of a Pressurized Water Reactor, Kernforschungszentrum Karlsruhe, Federal Republic of Germany, KFK 3380 (1982).

## GERMAIN

M. Germain and P. Pluot, Diluent Washing of Aqueous Phase Using Centrifugal Contactors, Proc. Int. Solvent Extraction Conf., 80-218 (September 1980).

## HAGAN

P. G. Hagan and J. D. Navratil, Secondary Recovery of Plutonium and Americium from Process Waste Streams by Solvent Extration, Rocky Flats Plant, RFP-2708 (January 1978).

## HOECHST

A. G. Hoechst, Flame-Retardant Finishing of Pile Carpeting, Ger. Offern. 2,825,818, January 11, 1979; Swiss Appl. 77/7,300, June 14, 1977. [Chemical Abstracts Reference 90:1390355]

## HORWITZ-1983

E. P. Horwitz, H. Diamond, and D. G. Kalina, Carbamoylmethylphosphoyl Derivatives as Actinide Extractants, Their Significance in the Processing and Recovery of Plutonium and Other Actinides, ACS Symp. Ser. 216 (Plutonium Chemistry), 433 (1983).

## HORWITZ-1984

E. P. Horwitz and D. G. Kalina, The Extraction of Am(III) from Nitric Acid by Octyl(Phenyl)-N,N-Diisobutylcarbamoylmethylphosphine Oxide-Tri-n-Butyl Phosphate Mixtures, Solv. Ext. Ion Exchange, 2, 179 (1984).

## KAPLAN

L. Kaplan, G. W. Mason, and E. P. Horwitz, Preparation and Properties of n-Octyl(Phenyl)-N,N-Diisobutylcarbamoylmethylphosphine Oxide (O $\phi$ D[IB]CMPO), Internal Report, Chemistry Division, Argonne National Laboratory (August 1983).

## KATZ

S. Katz and W. D. Bond, A Method of Estimating Distribution Coefficients of Degradation Products from Organophosphorus Extractants, Oak Ridge National Laboratory, ORNL/TM-6776 (May 1979).

## KAZANJIAN

A. R. Kazanjian and M. E. Killion, Radiation Stability and Acid Hydrolysis of DHDECMP, Chemistry Research and Development Annual Progress Report, November 1, 1980 to September 30, 1981, Rocky Flats Plant, RFP-3324, p. 14 (August 1982).

## KIRBY

A. J. Kirby and S. G. Warren, The Organic Chemistry of Phosphorus, Elsevier Publishing Company, New York (1967).

## M&amp;T

This discussion is based on literature provided by M&T Chemical Company.



## MASON

G. W. Mason, D. N. Metta, and D. F. Peppard, The Extraction of Selected M(III) Metals by Bis 2-ethylhexylphosphoric Acid in n-Heptane, J. Inorg. Nucl. Chem. 38, 2077 (1976).

## McCANN

J. McCann, Mutagenesis, Carcinogenesis, and the Salmonella Test, Chem. Tec. 682 (November 1976).

## MCISAAC-1976

L. D. McIsaac, J. D. Baker, and J. W. Tkachyk, "Actinide Removal from ICPP Wastes," in Idaho Chemical Programs Annual Technical Report Fiscal Year 1975, Idaho Chemical Processing Plant, ICP-1086, p. 100 (June 1976).

## MCISAAC-1979

L. D. McIsaac, J. D. Baker, J. F. Krupa, R. E. LaPointe, D. H. Meikrantz, and N. C. Schroeder, Study of Bidentate Compounds for Separation of Actinides from Commercial LWR Reprocessing Wastes, Idaho Chemical Processing Plant, ICP-1180 (May 1979)

## MCISAAC-1980

L. D. McIsaac, J. D. Baker, J. F. Krupa, D. H. Meikrantz, and N. C. Schroeder, Flowsheet Development Work at the Idaho Chemical Processing Plant for the Partitioning of Actinides from Acidic Nuclear Waste, ACS Symp. Ser. 117 (Actinide Separations), 395 (1980).

## MCISAAC-1981

L. D. McIsaac, J. F. Krupa, and N. C. Schroeder, Purifying Bidentate Organophosphorus Compounds, U.S. Patent 4276235, June 30, 1981 (Chemical Abstracts, 95:133161)

## MUSCATELLO

Personal communications between Anthony Muscatello (Rocky Flats Plant) and authors of this report in February and March, 1984.

## NAVRATIL

J. D. Navratil, Secondary Americium and Plutonium Recovery at Rocky Flats, presented at Conf. of Actinide Recovery from Acidic Wastes, Rocky Flats Plant, Golden, CO, May 4-5, 1976.

## NOWAK

Z. Nowak, M. Nowak, and A. Seydel, Examination of the Radiolytic Stability of DiAmyl-Amyl-Phosphonate-Dodecane-Nitric Acid System, Radiochem. Radioanal. Lett. 55, 337 (1982).

## PEPPARD

D. F. Peppard, G. W. Mason, and S. Lewey, Di-n-octylphosphinic Acid as a Selective Extractant for Metallic Cations, J. Inorg. Nucl. Chem. 27, 2065 (1965).

## RASMUSSEN

O. R. Rasmussen, Hanford Radioactive Tank Cleanout and Sludge Processing, Rockwell Hanford Operations, RHO-ST-30 (March 1980).

## SCHROEDER-1980A

N. C. Schroeder, L. D. McIsaac, D. H. Meikrantz, J. F. Krupa, and J. D. Baker, Purification and Properties of Dihexyl N,N-diethyl-carbamoylmethylenephosphonate, J. Inorg. Nucl. Chem. 42, 1029 (1980).

## SCHROEDER-1980B

N. C. Schroeder, L. D. McIsaac, and J. F. Krupa, Purification and Properties of Dihexyl N,N-diethylcarbamoylmethylenephosphonate, by Mercury (II) Precipitation, Exxon Nuclear Idaho Company, Inc., ENICO-1026 (January, 1980).

## SCHULZ-1971

W. W. Schulz, Macroreticular Ion-Exchange Resin Cleanup of Purex Process TBP Solvent, Proc. Int. Solvent Extraction Conf., Vol. I, Society of Chemical Industry, London, p. 174 (1971).

## SCHULZ-1972

W. W. Schulz, Macroreticular Anion Exchange Cleanup of TBP Solvent, Atlantic Richfield Hanford Co., ARH-SA-129 (May 1972).

## SCHULZ-1974

W. W. Schulz, Bidentate Organophosphorus Extraction of Americium and Plutonium, Atlantic Richfield Hanford Co., ARH-SA-203 (September 1974).

## SCHULZ-1975

W. W. Schulz and L. D. McIsaac, Removal of Actinides from Nuclear Fuel Reprocessing Waste Solutions with Bidentate Organophosphorus Extractants, Atlantic Richfield Hanford Co., ARH-SA-217 (August 1975).

## SCHULZ-1977A

W. W. Schulz and L. D. McIsaac, Bidentate Organophorus Extractants: Purification, Properties and Applications to Removal of Actinides from Acidic Waste Solutions, Atlantic Richfield Hanford Co., ARH-SA-263 (May 1977).

## SCHULZ-1977B

W. W. Schulz and L. D. McIsaac, Bidentate Organophosphorus Extractants: Purification, Properties and Applications to Removal of Actinides from Acidic Waste Solutions, Proc. of Int. Solvent Extraction Conf., Toronto, Canada, p. 619 (1977).

## SCHULZ-1982

W. W. Schulz and J. D. Navratil, Solvent Extraction with Neutral Bidentate Organophosphorus Reagents, Chapter 2, Recent Developments in Separation Science, Vol. VII, N. N. Li, ed., CRC Press, Inc., Boca Raton, FL (1982).

## SHOUN

R. R. Shoun, W. J. McDowell, and B. Weaver, Bidentate Organophosphorus Compounds as Extractants from Acidic Waste Solutions: A Comparative and Systematic Study, Proc. of Int. Solvent Extraction Conf., Toronto, Canada, p. 101 (1977).

SRL-1976

Savannah River Laboratory Quarterly Report, Waste Management, April-June 1976, Savannah River Laboratory, DPST-76-125-2 (October 1976).

SRL-1978

Savannah River Laboratory Quarterly Report, Waste Management, January-March 1978, Savannah River Laboratory, DPST-78-125-1.

TREYBAL

R. E. Treybal, Liquid Extraction, 2nd ed., McGraw-Hill Book Co., New York (1963).

VANDEGRIFT

G. F. Vandegrift, "Diluents for TBP Extraction Systems," Chapter 4 in The Science and Technology of Tributyl Phosphate, Vol. I, W. W. Schulz and J. D. Navratil, ed., CRC Press, Inc., Boca Raton, FL, to be published, summer 1984.

## APPENDIX A.

## TRUEX FLOWSHEET CALCULATIONS

Calculations for a TRUEX flowsheet with up to 42 metallic constituents required an overview of the process in order to determine which constituents had to be calculated in detail. The overview process is presented first. Then the various computational procedures are reviewed as to their relative advantages and disadvantages. Finally, the order in which the calculations were made is discussed.

### 1. Overview

An overview of the process can be gained by looking at the extraction factor for each constituent in each section of the equipment. (A section consists of all the stages between adjacent external feed points in an extraction unit.) The extraction factor is given by  $RD$  (the product,  $R \times D$ ), where  $R$  is the  $O/A$  flow ratio in the section and  $D$  is the distribution coefficient (or distribution ratio as it is referred to in other sections of the text) for the element in that section. Because no liquid is added or withdrawn within the section,  $R$  will be constant;  $D$  will normally be unchanged within a section. Thus, the extraction factor will usually be the same for each stage in the section. When the extraction factor is greater than 1, more of the element leaves a stage in the organic phase than in the aqueous phase. When the extraction factor is less than 1, more of the element leaves a stage in the aqueous phase than in the organic phase. When the extraction factor is 1, the element leaving a stage is equally distributed between the two phases. It is assumed the two phases are equilibrated when they leave a stage.

For an extraction/scrub unit, the metal ions to be separated are in the aqueous feed which enters the unit between the extraction and scrub sections. If  $RD$  is greater than one for both sections (Regime I), the element is concentrated in the organic phase and is carried out in the organic product. If  $RD$  is 1 for the extraction section but greater than 1 for the scrub section (Regime II), most of the element (90% to 95%) will be in the organic product. For this regime, the more extraction stages there are, the higher will be the concentration of this element in the organic product. If  $RD$  is less than 1 for one section and greater than 1 for the other section (Regime III), then the element will be split between the two effluents without any particular separation of the element. One normally tries to avoid this regime. For typical Regime III operation, the distribution coefficient does not change much between the extraction and scrub sections so that the extraction factor for the extraction section is less than 1 (Regime III-A). If an element encounters Regime III-A operation, both the extraction and scrub sections move the element away from the feed stage and discharge the element with the aqueous and organic effluents, respectively. For some special Regime III operations, the distribution coefficient can be much lower in the scrub section than in the extraction section so that the extraction factor for the scrub section is less than 1 (Regime III-B). If an element encounters Regime III-B operation, both the extraction and scrub sections retard the movement of the element away from the feed stage. This creates a very high concentration of the element at the feed stage, which can overload the organic phase and prevent the desired process separations from occurring. For this reason, Regime III-B is to be avoided in any process design. If  $RD$  is 1 for the scrub section but less than 1 for the extraction section (Regime IV), most of the

element (90% to 95%) will be in the aqueous raffinate. For this regime, the more scrub stages there are, the higher will be the concentration of this element in the aqueous raffinate. If RD is less than 1 for both sections (Regime V), the element remains in the aqueous phase and is carried out in the aqueous raffinate.

For a stripping unit, the metal ions to be stripped are in the organic feed. For the TRUEX process, the organic feed will be the organic product from the extraction/scrub unit. If an element has an RD greater than 1, it will remain in the organic phase. If the element has an RD less than 1, it will be stripped into the aqueous phase and come out in the aqueous effluent. The smaller the value of RD, the fewer the number of stripping stages that will be required to achieve a given level of decontamination.

This extraction factor analysis was used to derive an overview of the extraction/scrub flowsheets. The results of this analysis are given in Table A-1. For the  $O\phi D[IB]CMPO$  extractant, the distribution coefficients for DSW and CAW are not that different; this allows the metal ion regime for both flowsheets to be listed in a single column. Note that separation works well with all the actinides, lanthanides, technetium, and most of the yttrium in the organic product, as well as all the other fission product ions including most of the palladium and ruthenium in the aqueous raffinate. There are no elements split between the effluents, i.e., in Regime III. To get this separation, the O/A flow ratio in the extraction section ( $R_e$ ) must be 0.5. For the DHDECMP extractant, the distribution coefficients for MDSW and CAW are almost identical; this allows the metal ion regime for both flowsheets to be listed in a single column for a given  $R_e$  value. It was first thought that a  $R_e$  value of 1.5 should be used so that DHDECMP and  $O\phi D[IB]CMPO$  could be compared at the same extraction factor. A review of Table A-1 shows that this puts technetium in Regime III-B, which is unacceptable. To eliminate all elements from Regime III,  $R_e$  was decreased to 0.5. This puts Tc in the aqueous raffinate when it is preferred to have Tc in the organic product. Technetium in the aqueous raffinate is a trade-off that one must make when using DHDECMP.

In the extraction factor analysis shown on Table A-1, the Ru is listed in Regime IV because we expect about 90% of it to appear in the aqueous effluent. A more accurate picture may be that two Ru species are present, most in Regime V and the rest in Regime I. Thus, Ru could appear to be a Regime IV element based on the overall separation but actually be something more complex. Palladium may also form two species with different distribution coefficients. The organic phase component doing the extracting in these cases would be the TBP.

## 2. Calculations\*

Because many appropriate equations are available in the published literature [ALDERS, HAAS, LAWROSKI, and TREYBAL] and others have been developed here for computer calculations of flowsheet stream compositions, the use of computer simulation was studied. However, these equations become more difficult to use when the distribution coefficient varies from stage to stage, as it does with some constituents in the TRUEX process. When it appeared that a

---

\*Symbols are defined in Section 4 of this appendix.

Table A-1. Application of Extraction Factor Analysis to the Elements in the DSW or CAW Solutions with CMPO- or CMP-TRUEX Process Solvents

Regime	RD <sup>a</sup> for Extraction and Scrub Sections	Location of Metal Ions	Metal Ion Regime <sup>b</sup>		
			DSW or CAW with CMPO-TRUEX; R <sub>e</sub> = 0.5, R <sub>s</sub> = 2	MDSW or CAW with CMP-TRUEX; R <sub>e</sub> = 1.5, R <sub>s</sub> = 4.0	MSDW or CAW with CMP-TRUEX; R <sub>e</sub> = 0.5, R <sub>s</sub> = 2
I	Both greater than one	Essentially all in organic effluent	All actinides, all lanthanides, Tc	All actinides, all lanthanides, Y	All actinides, all lanthanides except Gd, Y
II	Factor at one for extraction, greater than one for scrub	Most (~90%) in organic effluent	Y	Pd	Gd
III	One factor less than one, the other greater than one <sup>c</sup>	Split between the effluents	None	Tc	None
IV	Factor at one for scrub, less than one for extraction	Most (~90%) in aqueous effluent	Pd, Ru	Ru	Pd, Tc
V	Both less than one	Essentially all in aqueous effluent	All other metal ions	All other metal ions	All other metal ions

<sup>a</sup>Extraction factor for an element is given by multiplying the O/A flow ratio (R) in a section by the distribution coefficient (D) for that element throughout the section.

<sup>b</sup>R<sub>e</sub> is the O/A flow ratio in the extraction section; R<sub>s</sub> is the O/A flow ratio in the scrub section; MDSW is DSW modified by the addition of aluminum as given in Table IV-1.

<sup>c</sup>Typically, the factor for the extraction section is less than one; and the factor for the scrub section is greater than one (Regime III-A). If this situation is reversed (Regime III-B), as it is for the Tc listed in this row, the Tc will have a difficult time getting out of the extraction unit and its concentration in the unit will become excessive, probably overloading the capacity of the extractant.

split scrub would be required, this procedure was abandoned because the equations were too cumbersome. However, two of the equations were used to estimate the number of stages needed in the extraction and stripping sections. For an extraction section with  $n_e$  stages and a feed concentration of  $x_f$ , the aqueous raffinate concentration of  $x_w$  is given by

$$x_w = x_f \frac{(R_e D - 1)}{[(R_e D)^{n_e + 1} - 1]} \quad (\text{A-1})$$

if  $R_e D$  is greater than 1 and the concentration in the organic feed is essentially zero for the element. For the extraction section, the larger the extraction factor, the fewer the stages that will be required to achieve a given decontamination factor. For a stripping unit with  $n_{st}$  stages and an organic feed concentration of  $y_f$ , the organic raffinate concentration of  $y_w$  is given by

$$y_w = y_f \frac{[(R_{st} D)^{-1} - 1]}{[(R_{st} D)^{-(n_{st} + 1)} - 1]} \quad (\text{A-2})$$

if  $R_{st} D$  is less than 1 and the concentration in the aqueous feed is essentially zero for the element. For the stripping unit, the smaller the extraction factor, the fewer the stages that will be required to achieve a given level of stripping.

The McCabe-Thiele method, which is described in detail elsewhere [HAAS, LAWROSKI, and TREYBAL], was used to complete the calculations for the flowsheets. With this graphical method, it is easy to (1) evaluate elements even though their distribution coefficients vary from stage to stage; (2) calculate the effect of two scrub sections (a split scrub) in the extraction/scrub unit; and (3) determine whether more stages in a section would improve a separation or have very little effect. The McCabe-Thiele method gives the element concentrations at steady-state conditions.

The two countercurrent laboratory runs reported in Appendix B involve CMPO-TRUEX solvent extraction of TRU from DSW. For these runs, it was important to know how fast the aqueous raffinate concentration would approach a steady-state value. The runs were labor-intensive and the amount of feed material was limited, yet enough test steps were needed to show clearly that the americium in the raffinate had attained a steady-state concentration that was low enough to make it a non-TRU waste. Since the McCabe-Thiele method works only for steady-state operation, it could not be used here. Complex computer programs could be used to make the calculations, but too much time would be required to bring such a program on-line, and, even then, extensive changes would be required to replace the uranium and plutonium data with the appropriate americium distribution coefficients. An alternative method to determine the approach of the raffinate to a steady-state concentration is the use of step-by-step calculations, as shown by ALDERS and TREYBAL. This calculation is normally tedious; however, it was found that, by use of electronic spreadsheets, the computation is greatly simplified. Using the DIGICALC electronic spreadsheet (WHY Systems, Inc., Redmond, WA), the rate at which the

americium concentration in the aqueous raffinate approached its steady-state value was calculated. These calculations give the concentration for each step\* and each stage of the run, as well as the steady-state concentration at each stage. Besides giving steady-state concentrations, the alternative calculational method also has other features of the McCabe-Thiele method; e.g., different distribution coefficients can be used for each stage and two scrub sections can be evaluated for an extraction/ scrub unit. Because the electronic spreadsheet does not have the graphical style of the McCabe-Thiele method, it does not show process constraints as clearly. Overall, the electronic spreadsheet works well and will be used for the detailed calculations in future flowsheet work.

### 3. Order of Calculations

In the order of calculations, the number of extraction stages was calculated first. This was done by using the decontamination factor for Am in the extraction section and Eq. A-1. Then, knowing the number of stages, one may calculate the nitric acid concentration at each stage by the McCabe-Thiele method. This method is then used to refine the Am calculation; this is necessary because the distribution coefficient for Am depends on the nitric acid concentration. In general, if an element was dependent on the concentration of some other element, the latter was calculated first. Not all elements were evaluated in detail by the McCabe-Thiele method. Evaluated in detail were (1) americium, (2) those elements which appear in Regimes II, III, and IV in Table A-1, (3) those key elements in Regime I whose extraction factors put them closest to Regime II, and (4) those key elements in Regime V whose extraction factors put them closest to Regime IV. Each key element in Regime I is concentrated almost entirely in the organic product of the extraction/scrub unit with a very low concentration in the aqueous raffinate. The other elements of Regime I have even lower concentrations; thus, in most cases, detailed calculations were not made. This is noted on the flowsheet tables by showing that the element has an aqueous-raffinate concentration less than the appropriate key element. Each key element in Regime V is concentrated almost entirely in the aqueous raffinate of the extraction/scrub unit with a very low concentration in the organic product. Because the other elements of Regime V have even lower concentrations, detailed calculations were not made in most cases. This is noted on the flowsheet tables by the element having an organic-product concentration less than the appropriate key element.

### 4. Nomenclature

A	Aqueous phase.
D	Ratio of the equilibrium concentration in the organic phase and that in the aqueous phase.
$n_e$	Number of extraction stages.
$n_{st}$	Number of stripping stages.
O	Organic phase.

---

\*That is, each liquid-liquid equilibration in a stage; thus a "step" corresponds to one residence time in a stage.



R	Organic-to-aqueous (O/A) flow ratio.
$R_e$	R for extraction section.
$R_s$	R for scrub section.
$R_{st}$	R for stripping unit.
$x_f$	Concentration of an element in the aqueous feed to the extraction section, <u>M</u> .
$x_w$	Concentration of an element in the aqueous raffinate from the extraction section, <u>M</u> .
$y_f$	Concentration of an element in the organic feed to the stripping unit, <u>M</u> .
$y_w$	Concentration of an element in the organic raffinate from the stripping unit, <u>M</u> .

## REFERENCES

## ALDERS

L. Alders, Liquid-Liquid Extraction, 2nd ed., Elsevier Science Publishers, New York (1959).

## HAAS

W. O. Haas, "Solvent Extraction: General Principles," Chapter IV in Chemical Processing of Reactor Fuels, J. F. Flagg, ed., Academic Press, New York, pp. 125-198 (1961).

## LAWROSKI

S. Lawroski, L. Burris, and W. A. Rodgers, "Chemistry and Chemical Engineering," Sec. 11 in Nuclear Engineering Handbook, H. Etherington, ed., McGraw-Hill Book Co., New York (1958).

## TREYBAL

R. E. Treybal, Liquid Extraction, 2nd ed., McGraw-Hill Book Co., New York (1963).

## APPENDIX B.

## COUNTERCURRENT TESTS OF TRU EX PROCESS FLOWSHEETS--EXPERIMENTAL DETAILS

1. The Synthetic DSW Solutiona. Introduction

The relative concentrations of chemical species in DSW are based on (1) the composition of CAW, (2) the chemistries of ions in acidic solution as the pH is greatly increased by hydroxide addition, and (3) actual measurements of the concentrations of some species in Hanford PUREX sludges. The concentrations of species were set by postulating that the sludge could be dissolved in the same volume that it precipitated out of; in other words, species such as lanthanides and actinides, which precipitate quantitatively from CAW, would have the same concentration in DSW that they have in CAW.

Technetium (as  $^{99}\text{TcO}_4^-$ ), although not expected to precipitate by hydroxide addition in CAW, was added to the synthetic DSW to further study its TRU EX solvent extraction chemistry. The low concentration of technetium would negate its effect on the extraction behavior of any other species.

The oxalate concentration in the feed stage was chosen to be 0.3M. The DSW stock solution, however, was prepared with a lower oxalic acid concentration (0.05M). The addition of oxalic acid at this stage was made primarily to facilitate the dissolution of zirconium nitrate in the waste by dissolving the oxalic acid and  $\text{Zr}(\text{NO}_3)_4$  together in a small volume of water.

b. Preparation of Feed

Tables B-1 through B-3 show the calculated and analytically measured composition of the synthetic DSW. Most elements were measured by inductively coupled plasma/atomic emission spectroscopy (ICP/AES) analysis; in the case of  $^{99}\text{Tc}$  and the TRU elements, measurements were made by radiometric analysis. In Table B-1, the concentration of oxalic acid listed with the non-fission product species is that of the final feed composition.

Two solutions, with differing neptunium concentrations, are listed in Table B-3. Solution 1 was used for the DSW feed in the counter-current experiment (to be discussed in detail below). Solution 2 was used for an ancillary counter-current experiment, which was run to test the effect of neptunium's concentration on its extractability. The rationale and results of this study are discussed in Section IV.B.

The americium concentration in the simulated DSW is more than an order of magnitude less than projected to be typical in DSW. The concentration of americium that we chose was based on having enough activity to measure the requisite decontamination of Am to produce a raffinate waste containing less than the 100 nCi/g TRU. Because the concentration of americium in actual DSW is projected to be small in comparison to the concentrations of the lanthanides that extract along with it, the concentration of Am has no measurable effect on solvent loading.

Table B-1. Composition of the Synthetic DSW:  
Nonfission Products

	Concentration, <u>M</u>	
	Added	Found <sup>a,b</sup>
HNO <sub>3</sub>	1.0	NA
Na	0.15	NA
Mg	0.0016	0.0017
Al	0.046	0.045
Ca	0.0014	0.0014
Cr	0.014	0.013
Mn	0.0045	0.0047
Fe	0.15	0.15
Ni	0.0080	0.0086
Cu	0.0018	0.0019
F <sup>-</sup>	0.008	NA
SO <sub>4</sub> <sup>2-</sup>	0.012	NA
H <sub>2</sub> C <sub>2</sub> O <sub>4</sub>	0.30	NA
NO <sub>2</sub> <sup>-c</sup>	0.005	NA

<sup>a</sup>NA means not analyzed.

<sup>b</sup>The ICP/AES analyses have a 3-10% error range; the magnitude of the error is a function of the element's concentration and the degree of interference from other elements.

<sup>c</sup>On addition of solid NaNO<sub>2</sub> to the feed, some reddish-brown gas (likely NO<sub>x</sub>) was released.

The simulated DSW stock solution was prepared as follows:

- (1) Oxalic acid, Zr(NO<sub>3</sub>)<sub>4</sub>, and Mo(VI) solution were mixed together with some additional water to form a solution.
- (2) All the other solid reagents were mixed together and dissolved in water.
- (3) All other volumes of standard solutions were mixed together.
- (4) The solutions from (2) and (3) were combined and the proper amount of nitric acid was added to the mixture. (The amount of concentrated HNO<sub>3</sub> was calculated by considering all the acid that had been added to the solution from the standard solutions.)
- (5) Solution (1) was then combined with the rest, and the resultant solution was brought to volume and warmed to 40-50°C to assure dissolution of all species.

Table B-2. Composition of Synthetic DSW Solution:  
Fission Products

	Concentration, M	
	Added	Found <sup>a</sup>
Se	$9.5 \times 10^{-5}$	$<1.6 \times 10^{-4}$ <sup>b</sup>
Sr	$1.4 \times 10^{-3}$	$1.4 \times 10^{-3}$
Y	$7.3 \times 10^{-4}$	$7.0 \times 10^{-4}$
Zr	$5.6 \times 10^{-3}$	$6.2 \times 10^{-3}$
Mo	$1.8 \times 10^{-4}$	$1.6 \times 10^{-4}$
Tc	$1.0 \times 10^{-5}$	$9.6 \times 10^{-6}$ <sup>c</sup>
Ru	$2.1 \times 10^{-3}$	$2.0 \times 10^{-3}$
Rh	$5.7 \times 10^{-4}$	$5.7 \times 10^{-4}$
Pd	$5.4 \times 10^{-4}$	$6.6 \times 10^{-4}$
Ag	$3.6 \times 10^{-5}$	$3.0 \times 10^{-5}$
Cd	$5.0 \times 10^{-5}$	$4.4 \times 10^{-5}$
Te	$3.3 \times 10^{-4}$	$3.3 \times 10^{-4}$
Ba	$1.1 \times 10^{-3}$	$2.1 \times 10^{-4}$ <sup>d</sup>
La	$1.0 \times 10^{-3}$	$9.5 \times 10^{-4}$
Ce	$2.4 \times 10^{-3}$	$2.3 \times 10^{-3}$
Pr	$9.2 \times 10^{-4}$	$8.6 \times 10^{-4}$
Nd	$2.7 \times 10^{-3}$	$2.6 \times 10^{-3}$
Sm	$3.9 \times 10^{-4}$	$3.8 \times 10^{-4}$
Eu	$4.8 \times 10^{-5}$	$4.9 \times 10^{-5}$
Gd	$1.2 \times 10^{-5}$	NA <sup>e</sup>

<sup>a</sup>The ICP/AES analyses have a 3-10% error range; the magnitude of the error is a function of the element's concentration and the degree of interference from other elements.

<sup>b</sup>The amount added to solution was below its ICP/AES detectability.

<sup>c</sup>Based on radiochemical analysis of <sup>99</sup>Tc.

<sup>d</sup>The low concentration of Ba ion is due to its precipitation as BaSO<sub>4</sub>.

<sup>e</sup>NA means not analyzed.

Table B-3. Composition of Synthetic DSW  
Feed Solutions: Actinides

	Conc., M	Activity, dpm/L
<u>SOLUTION 1</u>		
$^{238}\text{U}$	$1 \times 10^{-4}$	$2 \times 10^4$
$^{237}\text{Np}$ - $^{239}\text{Np}$ <sup>a</sup>	$1.0 \times 10^{-6}$	$9 \times 10^8$ <sup>b</sup>
$^{242}\text{Pu}$	$1.6 \times 10^{-6}$	$3.3 \times 10^6$
$^{241}\text{Am}$	$7.0 \times 10^{-6}$	$1.3 \times 10^{10}$
<u>SOLUTION 2</u>		
$^{238}\text{U}$	$1 \times 10^{-4}$	$2 \times 10^4$
$^{237}\text{Np}$ - $^{239}\text{Np}$	$2 \times 10^{-4}$	$9 \times 10^8$ <sup>b</sup>
$^{242}\text{Pu}$	$1.6 \times 10^{-6}$	$3.3 \times 10^6$
$^{241}\text{Am}$	$7.0 \times 10^{-6}$	$1.3 \times 10^{10}$

<sup>a</sup>The bulk of the Np concentration was as  $^{237}\text{Np}$ ; the bulk of its radioactivity was supplied by  $^{239}\text{Np}$ .

<sup>b</sup>Activity level at the start of the experiment; the short half-life of  $^{239}\text{Np}$  (2.35 days) was corrected to the same time for comparison of all counts.

(6) On cooling, a small amount of precipitate was visible on the bottom of the beaker and it was removed by filtering the solution through a medium glass frit. (Analysis of this solid showed it to contain Ba and a lesser amount of Ag; this result explains the lower than added concentrations of these species in the synthetic DSW solution.)

(7) Three days before the start of the countercurrent run, sodium nitrite was added to two one-liter portions of the synthetic DSW, making them  $5 \times 10^{-3}\text{M}$  in nitrite. Uranium was added to the liter of solution to be used for the non-active countercurrent experiment, and the actinides and Tc mixture was added to the other liter of DSW.

Tables B-4 and B-5 are a list of ingredients for preparing four liters of simulated, nonradioactive DSW.\*

\*This method was chosen based on the chemicals and solutions that were on hand.

Table B-4. Solid Additions in Preparation of Four Liters of Synthetic DSW Solution

Species Added	Form of Addition	Amount for 4 L, g	Amount Added, g	Other Species Added in Conjunction
Na <sup>+</sup>	NaNO <sub>3</sub>	43.18	43.19	NO <sub>3</sub> <sup>-</sup>
Fe <sup>3+</sup>	Fe(NO <sub>3</sub> ) <sub>3</sub> · 9H <sub>2</sub> O	242.2	242.25	NO <sub>3</sub> <sup>-</sup>
Mg <sup>2+</sup>	Mg(NO <sub>3</sub> ) <sub>2</sub> · 4H <sub>2</sub> O	1.64	1.64	NO <sub>3</sub> <sup>-</sup>
Al <sup>3+</sup>	Al(NO <sub>3</sub> ) <sub>3</sub> · 9H <sub>2</sub> O	69.03	69.04	NO <sub>3</sub> <sup>-</sup>
Ca <sup>2+</sup>	Ca(NO <sub>3</sub> ) <sub>2</sub> · 4H <sub>2</sub> O	1.28	1.28	NO <sub>3</sub> <sup>-</sup>
Cr <sup>3+</sup>	Cr(NO <sub>3</sub> ) <sub>3</sub> · 9H <sub>2</sub> O	21.61	21.63	NO <sub>3</sub> <sup>-</sup>
Mn <sup>2+</sup>	MnSO <sub>4</sub> · H <sub>2</sub> O	3.04	3.04	SO <sub>4</sub> <sup>2-</sup>
Ni <sup>2+</sup>	Ni(NO <sub>3</sub> ) <sub>2</sub> · 6H <sub>2</sub> O	9.31	9.32	NO <sub>3</sub> <sup>-</sup>
Cu <sup>2+</sup>	Cu(NO <sub>3</sub> ) <sub>2</sub> · 3H <sub>2</sub> O	1.69	1.69	NO <sub>3</sub> <sup>-</sup>
F <sup>-</sup>	NaF	1.34	1.34	Na <sup>+</sup>
SO <sub>4</sub> <sup>2-</sup>	Na <sub>2</sub> SO <sub>4</sub>	4.26	4.26	Na <sup>+</sup>
C <sub>2</sub> O <sub>4</sub> <sup>2-</sup> <sup>a</sup>	H <sub>2</sub> C <sub>2</sub> O <sub>4</sub> · 2H <sub>2</sub> O	25.22	25.25	H <sup>+</sup>
Zr <sup>4+</sup>	Zr(NO <sub>3</sub> ) <sub>4</sub> · 5H <sub>2</sub> O	7.10	7.30 <sup>b</sup>	NO <sub>3</sub> <sup>-</sup>
Ru(NO) <sup>3+</sup>	Ru(NO) (NO <sub>3</sub> ) <sub>3</sub>	2.66	2.67	NO <sub>3</sub> <sup>-</sup>
Ba <sup>2+</sup>	Ba(NO <sub>3</sub> ) <sub>2</sub>	1.15	1.15	NO <sub>3</sub> <sup>-</sup>
Sr <sup>2+</sup>	Sr(NO <sub>3</sub> ) <sub>2</sub>	1.18	1.18	NO <sub>3</sub> <sup>-</sup>

<sup>a</sup>A single addition to make the solution 0.05M and help in dissolving Zr.

<sup>b</sup>Because an ICP/AES analysis of a solution of this salt showed a lower concentration than this formula weight allows, greater amounts of this material were added than was calculated from the molecular weight of Zr(NO<sub>3</sub>)<sub>4</sub>·5H<sub>2</sub>O. This weight corresponds to that difference.

Table B-5. Liquid Additions in Preparation of Four Liters of Synthetic DSW Solution

Species Added	Form of Addition	Amount for 4 L, mL	Means of <sup>a</sup> Reaching Volume, mL	Other Species Added in Conjunction
Cd <sup>2+</sup>	0.0120M (1.35 g Cd/L) Cd(NO <sub>3</sub> ) <sub>2</sub> solution	16.7	4(4.17)	NO <sub>3</sub> <sup>-</sup>
Mo(VI)	0.0103M Na <sub>2</sub> MoO <sub>4</sub> ·2H <sub>2</sub> O	70.0	70 mL	Na <sup>+</sup>
Y <sup>3+</sup>	0.0843M Y <sup>3+</sup> solution in 0.2M HNO <sub>3</sub>	34.6	7(4.94)	H <sup>+</sup> , NO <sub>3</sub> <sup>-</sup>
Rh <sup>3+</sup>	0.885M (91.1 g Rh/L) solution in 3M HNO <sub>3</sub>	2.58	2.58	H <sup>+</sup> , NO <sub>3</sub> <sup>-</sup>
Pd <sup>2+</sup>	0.118M (12.6 g Pd/L) solution of Pd(NO <sub>3</sub> ) <sub>2</sub> in 5.4M HNO <sub>3</sub>	18.2	4(4.55)	H <sup>+</sup> , NO <sub>3</sub> <sup>-</sup>
Ag <sup>+</sup>	1M AgNO <sub>3</sub> solution	0.144	0.144	NO <sub>3</sub> <sup>-</sup>
La <sup>3+</sup>	0.144M solution in 0.02M HNO <sub>3</sub>	27.8	6(4.63)	H <sup>+</sup> , NO <sub>3</sub> <sup>-</sup>
Ce <sup>3+</sup>	0.265M solution in 0.25M HNO <sub>3</sub>	36.2	8(4.53)	H <sup>+</sup> , NO <sub>3</sub> <sup>-</sup>
Pr <sup>3+</sup>	0.130M solution in 0.07M HNO <sub>3</sub>	28.3	6(4.72)	H <sup>+</sup> , NO <sub>3</sub> <sup>-</sup>
Nd <sup>3+</sup>	0.384M solution in 0.02M HNO <sub>3</sub>	28.1	6(4.68)	H <sup>+</sup> , NO <sub>3</sub> <sup>-</sup>

(contd)

Table B-5. (contd)

Species Added	Form of Addition	Amount for 4 L, mL	Means of <sup>a</sup> Reaching Volume, mL	Other Species Added in Conjunction
Sm <sup>3+</sup>	0.0872M solution in 0.1M HNO <sub>3</sub>	17.9	2(5) + 2(3.85)	H <sup>+</sup> , NO <sub>3</sub> <sup>-</sup>
Eu <sup>3+</sup>	0.0168M solution in 0.01M HNO <sub>3</sub>	11.4	2(5) + 2(0.7)	H <sup>+</sup> , NO <sub>3</sub> <sup>-</sup>
Gd <sup>3+</sup>	0.0113M solution in 0.01M HNO <sub>3</sub>	4.25	4.25	H <sup>+</sup> , NO <sub>3</sub> <sup>-</sup>
SeO <sub>4</sub> <sup>2-</sup>	0.8 g Se/L solution in 0.005M HNO <sub>3</sub>	37.5	38.0	H <sup>+</sup> , NO <sub>3</sub> <sup>-</sup>
Te(OH) <sub>6</sub>	0.0345M solution in 3M HNO <sub>3</sub>	37.5	38.0	H <sup>+</sup> , NO <sub>3</sub> <sup>-</sup>
HNO <sub>3</sub>	15.6M solution	241.0	2(100) + 41	-

<sup>a</sup>For greater accuracy and ease, multiple volumes were made with a 0-5000  $\mu$ L Pipetman™ variable volume pipette. For example, 4(4.17) signifies 4 separate 4.17 mL aliquots.

## 2. Experimental Description

### a. Apparatus

The countercurrent experiments were performed in a series of ten ~100 mL, water-jacketed separatory funnels with flared funnel tops (for easy pouring of liquids into them). The phases in each funnel were mixed by a Sargent-Welch stainless steel centrifugal agitator rotated by a light duty, electronically controlled, variable-speed stirring motor.

The funnels were heated to  $40 \pm 1^\circ\text{C}$  by two circulating thermostatic baths. In one set of six separatory funnels, the temperature measured inside the funnel was  $41.0^\circ\text{C}$  at stage 10 and  $39.2^\circ\text{C}$  at stage 5. In the second set of funnels, stage 4 was  $40.4^\circ\text{C}$  and stage 1 was  $39.6^\circ\text{C}$ . The organic and aqueous phases were delivered into beakers for transferring them into adjoining funnels. The beakers were handled with tongs to minimize the spread of activity.



b. Preparation of Solutions

(1) TRUEX Solvent

The chemicals used for the TRUEX solvent were 0.2M  $O\phi D[IB]CMPO$  (formula wt. = 407.6 g) and 1.4M TBP (formula wt. = 266.3 g) diluted to volume with Conoco C<sub>12</sub>-C<sub>14</sub>. To prepare one liter of TRUEX solvent requires 372.8 g of TBP and 81.5 g of pure  $O\phi D[IB]CMPO$ . Because the commercially prepared CMPO compound was 95% pure, 85.8 g of this material was added to one liter.

The weighed portion of  $O\phi D[IB]CMPO$  was transferred to a dry, tared, one-liter volumetric flask; this transfer was accomplished by using a powder funnel and Teflon<sup>™</sup>-coated spatula. The TBP was weighed in a beaker and then used to rinse the  $O\phi D[IB]CMPO$  from its beaker. Conoco 12-14 was then used to rinse both beakers and the powder funnel. The  $O\phi D[IB]CMPO$  was dissolved in the mixture of TBP-NPH after shaking and warming to room temperature. (Dissolution of TBP and  $O\phi D[IB]CMPO$  in NPH is an endothermic process.)

After standing overnight, the solution of  $O\phi D[IB]CMPO$  and TBP in NPH was diluted to volume with Conoco 12-14. The density of the resultant 0.2M CMPO-1.4M TBP-NPH solution was 0.882 g/mL.

After preparation, the TRUEX solvent was washed twice with a 0.25M  $Na_2CO_3/0.05M Na_2C_2O_4$  solution (2/1 phase ratio), followed by water washes.\* The TRUEX solvent was equilibrated with 1M  $HNO_3$  right before its addition to stage 1 of the countercurrent experiment.

(2) Scrub Number 1

A 500 mL solution of Scrub 1 (2.5M  $HNO_3$  and 0.06M  $H_2C_2O_4$ ) was prepared by diluting 113.2 g of concentrated  $HNO_3$  and 3.79 g of  $H_2C_2O_4 \cdot 2H_2O$  with high purity water.

(3) Scrub Number 2

A 500 mL solution of Scrub 2 (0.5M  $HNO_3$  and 0.01M  $Fe^{3+}$ ) was prepared by diluting 22.65 g of concentrated  $HNO_3$  and 2.02 g of  $Fe(NO_3)_3 \cdot 9H_2O$  with high purity water.

(4) Strip Number 1

One liter of Strip 1 (0.01M  $HNO_3$  and 0.005M HAN) was prepared by diluting 9.95 g of a 1.045M  $HNO_3$  solution and 1.79 mL of a 2.8M HAN solution with high purity water.

---

\*There were phase disengagement problems with these carbonate washes that were not noted before when the >99% pure CMPO was used. The cause of this problem and its solution are discussed in Section V.E.

(5) Strip Number 2

One liter of Strip 2 (0.1M oxalic acid) was prepared by diluting 12.61 g of  $\text{H}_2\text{C}_2\text{O}_4 \cdot 2\text{H}_2\text{O}$  with high purity water.

(6) DSW Feed Solution (Cold)

To two liters (2170 g) of DSW stock solution (described earlier) was added 64.7 g of additional  $\text{H}_2\text{C}_2\text{O}_4 \cdot 2\text{H}_2\text{O}$  (0.3M oxalic acid) and 0.69 g  $\text{NaNO}_2$  (0.005M  $\text{NO}_2^-$ ). Dilution with scrub solutions in the feed stage would (before equilibration with the organic phase) give a total oxalate concentration of 0.23M. The small volume change associated with the addition of solids to the DSW was ignored.

No precipitation of species was observed on addition of this high concentration of oxalic acid to the DSW, and none was observed on standing. One half of this solution was used as is (except for the addition of uranyl nitrate to bring its [U] to  $1 \times 10^{-4}\text{M}$  for the first cold counter-current experiment). The other half was spiked with radionuclides for use as the "hot" solution described below.

(7) DSW Feed Solution (Hot) 1

Uranium, neptunium, plutonium, americium, and technetium were introduced into the synthetic DSW solution by the following procedure.

An intermediate stock solution, 5 mL in volume and 1M in  $\text{HNO}_3$ , containing the required quantity of each nuclide was prepared. This intermediate stock solution was then transferred into one liter of DSW-0.30M  $\text{H}_2\text{C}_2\text{O}_4$ -0.005M  $\text{HNO}_2$ , using an additional 5 mL of 1M  $\text{HNO}_3$  as a rinse. All radionuclides were from ANL stocks and contained <0.1% by activity of other radioactive isotopes other than daughters.

Neptunium-239 was prepared by its separation from 2 mg of  $^{243}\text{Am}$ , using an extraction chromatographic procedure [HORWITZ]. A 9M HCl solution (prepared from Ultrex™ acid and ultrapure water) containing the  $^{243}\text{Am}/^{239}\text{Np}$  was loaded on a column (3-mm ID by 5-cm high) containing Aliquat™-336 absorbed on Porasil-C™ (25  $\mu\text{m}$  in diameter). Under these conditions, neptunium is largely tetravalent and absorbs on the column as  $\text{NpCl}_6^{2-}$ . Americium(III) is not absorbed on the column and is thoroughly rinsed from the column by eluting with ten bed volumes of 9M HCl. The  $^{239}\text{Np}$  is stripped from the column using three bed volumes of 0.1M HCl. The required quantity of  $^{237}\text{Np}$  (which contained <0.05% by activity  $^{238}\text{Pu}$ ) from a 2M  $\text{HNO}_3$  stock solution was added to the  $^{239}\text{Np}$  strip solution, and the mixture evaporated to dryness twice with 6M  $\text{HNO}_3$ . After the final evaporation, the residue [probably  $\text{NpO}_2(\text{NO}_3)_2$ ] was dissolved in 2 mL of 1M  $\text{HNO}_3$  and made 0.1M in  $\text{NaNO}_2$ . The nitrite reduced Np(VI) to Np(V), which was observable by the color change. The above oxidation-reduction procedure ensured isotopic equilibration of  $^{239}\text{Np}$  and  $^{237}\text{Np}$ .

Aliquots from standardized stock solutions of uranium (natural isotopic abundance), plutonium (atomic weight percent:  $^{242}\text{Pu}$ , 99.9;  $^{241}\text{Pu}$ , 0.002;  $^{240}\text{Pu}$ , 0.013; and  $^{239}\text{Pu}$ , 0.079),  $^{241}\text{Am}$ , and  $^{99}\text{Tc}$  were added to the  $^{237,239}\text{Np}$  solution. (All stock solutions were in nitric acid.) The resultant mixture was then added to the DSW as described above.

The only difference in the procedure for the two hot DSW feeds (Table B-3) was the addition of different quantities of  $^{237}\text{Np}$ .

c. Experimental Design and Procedure

Figure B-1 shows the flow design of the countercurrent experiments; Table B-6 shows the volumes added at the proper stages for both experiments to match the relative flows of that figure.

The countercurrent experiments were performed in the "double-diamond" mode described by Peppard [PEPPARD]. This was done to ensure simplicity of operation and adequate volumes of raffinate and loaded-organic samples for later experiments.

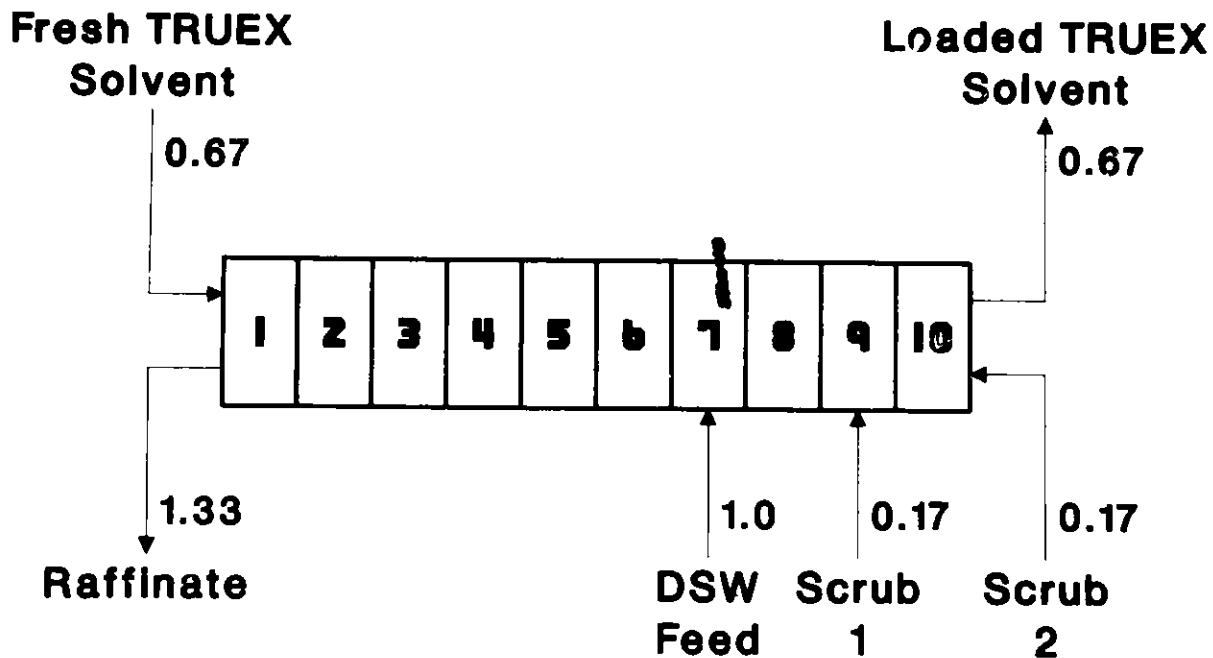

Fig. B-1. The Experimental Design and Flow Ratios of the Two Countercurrent Experiments (Boxes numbered 1-10 represent the separatory funnels or stages)

(1) Procedures for Countercurrent Experiments

Scrub solutions were added by syringe (10 mL plastic, disposable type) with an estimated accuracy and precision of  $\sim 5\%$ . A graduated cylinder was used to measure and add the organic phase to the funnel at stage 1, again with an accuracy and precision of  $\sim 5\%$ . Because of the high activity

Table B-6. Volume Additions in the Two Counter-current Experiments

Stage No.	Addition Solution	Volume Used in Experiment, <sup>a</sup> mL	
		Cold	Hot
	CMPO-TRUEX		
1	Process Solvent	28	20
7	Feed	42	30
9	Scrub 1	7	5
10	Scrub 2	7	5

<sup>a</sup>Cold refers to the first experiment where all species but the radionuclides  $^{99}\text{Tc}$ ,  $^{242}\text{Np}$ - $^{239}\text{Np}$ ,  $^{242}\text{Pu}$ , and  $^{241}\text{Am}$  were present in the feed; hot refers to the experiment where all species were present.

level of the hot feed solution, a Chempette™ repetitive dispenser, surrounded by lead bricks, was used to contain and dispense feed solution. A highly acid-resistant tubing transferred the feed solution to funnel 7 from the dispenser. The dispenser is accurate to 0.5 mL (by calibration, to 0.03 mL) and is reproducible to 0.05 mL.

When solutions had been transferred to each funnel, they were allowed to come to thermal equilibrium for ~2 minutes and were then stirred for ~1 minute. The stirring speed was set by visually observing complete dispersion of phases in each funnel. After stirring was complete and the phases completely disengaged, the aqueous and organic phases were removed from each funnel and left to sit until this operation was complete. Following the diagram of Fig. B-1, all the organic phases were transferred one separatory funnel to the right and each aqueous phase one funnel to the left. Fresh feed, scrub 1, scrub 2, and organic solvent were added at their proper stage, and the procedure was repeated, all ten stages running simultaneously.

As the loaded organic samples emerged from stage 10, they were labeled by the double diamond technique; i.e., the first and second samples were numbered 1 and 1', the third and fourth samples were numbered 2 and 2', and so on. The same labeling procedure was used for the raffinate samples. At the end of the cold run, 8 mL of the organic phase was removed from every stage; 16 mL of aqueous phase was removed from the extraction stages (1-7); 4 mL of aqueous phase was removed from scrub stages 8 and 9; and 2 mL of aqueous phase was removed from scrub stage 10. The remaining organic and aqueous phases were allowed to sit in the separatory funnels overnight.

The hot run was begun by substituting the radioisotope-containing feed for the cold feed used the previous day. The volumes of the feed, organic, and two scrub solutions were all reduced proportionately to match the lower volumes of the solutions in the ten stages (Table B-6).

After the requisite number of feeds had passed through the system to reach the calculated >90% of steady-state condition for [ $^{241}\text{Am}$ ] in the raffinate, the separatory funnels were drained and the organic and aqueous phases were separated and labeled for further testing and analysis.

## (2) Additional Procedures

Stage 0. A 4 mL sample was removed from the aqueous phase of stage 1 and the remainder was contacted with fresh organic phase.

Scrub Stages 11, 12, and 13. The last two loaded organic phases from the hot run that left the system prior to shutdown were combined and equilibrated with three additional portions of fresh scrub 2 in a O/A phase ratio of 4:1.

Strips 1 through n. The loaded organic phase that emerged from stage 13 was equilibrated with strip solution 1 in a O/A phase ratio of 2:1 for a number of consecutive strips (this number varied for the hot and cold runs). For the cold run, a sample of each strip solution was tested for the presence of lanthanides by the addition of oxalic acid; a precipitate indicated the presence of lanthanides. The progress of americium and neptunium stripping was monitored by removing small aliquots of the organic phase for  $\gamma$ -analysis between strips. The strips were combined for further Tc and Pu analyses. After an average of seven strips, the organic phase was divided. Part was saved and part was stripped further by strip 2 solution.

Oxalate Strips. After the organic phase was stripped by a series of dilute-nitric acid-HAN contacts, it was consecutively equilibrated with two volumes of strip solution 2 in a O/A phase ratio of 2:1. These two strip solutions were combined and saved for later Tc and Pu analyses.

## (3) A Second Hot Countercurrent Experiment

An ancillary experiment was performed after the analysis of data showed that the decontamination factor for Np in the countercurrent experiment was a disappointing value of 6, and the efficiency of stripping neptunium was low. It was hypothesized that the low Np extraction was due to the relatively low concentration of neptunium in the feed (Table B-3). To test this hypothesis, a three-stage countercurrent experiment was undertaken with the same equipment and volumes as the hot countercurrent experiment. The feed stage was again stage 7; both scrub solutions were combined in stage 8; and the TRUEX solvent entered at stage 6. Because of the limited volume of feed, a single-diamond experiment was run in which the addition of feed in stage 7 was alternated with the addition of solvent and scrub in stages 6 and 8. Four raffinate samples were collected before shutdown, after which the organic and aqueous phases from each stage were collected for analysis.

(4) Distribution Ratio Measurements of  $H_2C_2O_4$  and  $HTcO_4$ 

Carbon-14 labeled oxalic acid was used to measure the distribution ratio of oxalic acid ( $D_{H_2C_2O_4}$ ) in the near-steady-state solutions removed from stages at the conclusion of the cold countercurrent experiment. The labeled oxalic acid was purified by precipitating  $Ca^{14}C_2O_4$ , dissolving the precipitate of  $HNO_3$ , and removing the  $Ca^{2+}$  by a cation exchange column on the hydrogen ion cycle. (The major impurity was  $^{14}C$  labeled formic acid.) The  $D_{H_2C_2O_4}$  values were measured by spiking samples of the aqueous phases of each stage obtained from the cold run and equilibrating them with the corresponding organic phase at  $40^\circ C$  for four minutes. Phase ratios were the same as shown in Fig. B-1. Radiometric assay of the  $^{14}C$  oxalic acid was performed with a liquid scintillation counter.

The distribution ratios of  $HTcO_4$  were measured in the same manner as  $D_{H_2C_2O_4}$ , namely, by spiking samples of aqueous phase from the cold run with  $^{99}Tc$  and equilibrating them with a sample of the corresponding organic phase at  $40^\circ C$  for four minutes. Phase ratios were the same as shown in Fig. B-1. Radiometric assay of the  $^{99}Tc$  was performed using liquid scintillation counting.

d. Analytical Methods(1) ICP/AES Analysis(a) Sample Preparation

To measure the distribution ratios of each element in each stage, samples had to be quantitatively diluted for ICP/AES analysis because of the high concentrations of the major constituents. The aqueous phase dilution was a simple matter of taking a measured aliquot from each phase and diluting it with  $5M$   $HNO_3$  in high purity water to volume in a 50 mL volumetric flask. Four milliliter aliquots were taken from stages 1-7, 2 mL aliquots from stages 8 and 9, and 1 mL aliquots from stages 10 and 11.

The procedure for organic phase analysis was more complicated; the cations had to be first quantitatively stripped from the CMPO-TRUEX solvent before dilution. The organic phases' cationic content was removed by four consecutive strips of (1)  $1.5M$   $HNO_3/0.05M$  oxalic acid, (2) two water washes, and (3)  $5M$   $HNO_3$ . A 2 mL aliquot of each organic phase was contacted with 4 mL of each strip solution. All four strip solutions were combined and diluted to 50 mL with  $5M$   $HNO_3$ . The lanthanides precipitated out of the organic phases during the water washes but dissolved again when they were combined with the  $5M$  nitric acid solution.

(b) Analytical Measurements

The ICP/AES analysis was performed by Edmund Huff (Analytical Chemistry Laboratory, Chemical Technology Division, Argonne National Laboratory). The elements that were measured and the detection limits for each element are presented in Table B-7. Because of the dilution of samples for analysis, the concentration limits for the actual countercurrent experiment solutions are higher by their dilution fraction (50, 25, or 12.5 depending on the solution's stage number).

Table B-7. Elements Measured by ICP/AES Analysis and Their Detection Limits

Element	Detection Limit, $\mu\text{g/mL}$	Element	Detection Limit, $\mu\text{g/mL}$
Ag	< 0.02	Mo	< 0.05
Al	< 0.1	Nd	< 0.1
Ba	< 0.02	Ni	< 0.02
Ca	< 0.3	Pd	< 0.1
Ce	< 0.1	Pr	< 0.1
Cd	< 0.01	Rh	< 0.1
Cr	< 0.02	Ru	< 0.1
Cu	< 0.01	Sm	< 0.05
Eu	< 0.01	Sn	< 0.02
Fe	< 0.02	Te	< 0.1
La	< 0.02	Y	< 0.01
Mg	< 0.02	Zr	< 0.02
Mn	< 0.005		

(2) Americium Analysis

Aliquots of both organic and aqueous phases were placed directly in  $\gamma$ -counting vials with no further treatment. The size of the aliquot was determined by the expected activity level of the sample. The aliquots were diluted in the vials by either NPH or water to 2 mL so that their counting geometries would be similar.

The vials were inserted into a Beckman Biogamma<sup>™</sup> automatic  $\gamma$ -counter with NaI(Tl) well detector. One of the counter's energy windows was set for measuring the 59.6 keV gamma emission of  $^{241}\text{Am}$ . Suitable allowances were made for background and for the appearance and decay of  $^{239}\text{Np}$  activity in the  $^{241}\text{Am}$  window. The  $^{241}\text{Am}$  activities were counted during and right after the countercurrent experiments for quick but inaccurate analysis to monitor the progress of the experiment and were counted again much later, after the short-lived  $^{239}\text{Np}$  had died away, for more accurate measurements.

(3) Neptunium Analysis

The same samples that were counted by gamma analysis for  $^{241}\text{Am}$  activities were simultaneously counted for  $^{239}\text{Np}$  activity. A second energy window, set for all gamma energies above 100 keV, was used to measure  $^{239}\text{Np}$  activity. Because initially the levels of  $^{239}\text{Np}$  activity were high compared to all other activities with gamma emission above 100 keV in the samples, this window gave excellent correlations to the  $^{239}\text{Np}$  activities in the sample. The measured activities were corrected for the short half-life of  $^{239}\text{Np}$  (2.33 days).

Although the  $^{239}\text{Np}$  and  $^{241}\text{Am}$  isotopes were the only important source of  $\gamma$ -activity initially, as the  $^{239}\text{Np}$  decayed away, it was eventually possible to identify and use the gamma rays from  $^{237}\text{Np}$  and  $^{233}\text{Pa}$  to follow changes in neptunium concentration. Their signal from an intrinsic germanium detector was routed through a preamplifier, an amplifier, and a 4096 channel pulse height analyzer.

#### (4) Plutonium Analysis

Because plutonium was expected to have a high distribution ratio in the CMPO-TRUEX solvent extraction system, raffinate samples were not analyzed for their plutonium content; instead, the near steady-state aqueous solutions were analyzed from stages 4 through 7, along with the feed solution (as a standardization point) and several strip solutions. As expected, the aqueous phase concentration of plutonium in stage 4 was barely perceptible; thus plutonium would not be measurable in extraction stages 1 through 3 or in the raffinate samples. Isotopic dilution/mass spectrometric analysis was selected for plutonium analysis.

This analytical technique requires near weightless sample and isotopic equilibrium between  $^{242}\text{Pu}$  and the  $^{239}\text{Pu}$  spike.

##### (a) Sample Preparation

Twenty milliliter aliquots of the feed solution and the aqueous phases from stages 4 through 7 were combined with the requisite quantities of concentrated  $\text{HNO}_3$  and  $\text{NaNO}_2$  solution to bring the  $\text{HNO}_3$  concentration to  $4\text{M}$  and the  $\text{NaNO}_2$  concentration to  $0.05\text{M}$ . In addition, 4 mL each of the seven consecutive strip #1 solutions (designated  $\Sigma$  strip #1) was treated as above. A known amount of a NBS-949e  $^{239}\text{Pu}$  standard was added to each sample according to the schedule recorded in Table B-8. The spiked solutions were allowed to stand for two days at room temperature so that the plutonium isotopes would achieve isotopic equilibrium.

Plutonium was separated from all other constituents, except Np, by extraction of the spiked samples with 15 vol % Aliquat-336<sup>™</sup> nitrate in xylene using an O/A phase ratio of 1:2. After extraction, the organic phase was scrubbed three times with an equal volume of  $5\text{M}$  nitric acid (to ensure a high decontamination of the macroconstituents from the Pu, the tips of the separatory funnels were carefully rinsed with high purity water during the scrubbing operations). The scrubbed organic phase was stripped three times with an equal volume of  $1\text{M}$  formic acid- $0.1\text{M}$   $\text{HNO}_3$ - $0.05\text{M}$  HAN.

The combined strip solutions from each sample were evaporated to 4 mL by mild heating. Each concentrated strip solution was then contacted with three 2 mL portions of 2-ethylhexanol to remove entrained and/or solubilized extractant. The resultant washed, concentrated strip solutions were then given to the mass spectrometry laboratory for analysis.



Table B-8.  $^{239}\text{Pu}$  Addition to Samples of  $^{242}\text{Pu}$  for Isotopic Dilution/Mass Spectrometric Analysis

Sample	Stock Used, $\mu\text{g/mL}$	Volume Used, $\mu\text{L}$	$[^{239}\text{Pu}]$ Added to Solution, ng
Feed	282.27	34.2	$9.68 \times 10^3$
Aq-7	4.84 <sup>a</sup>	20	$9.68 \times 10^1$
Aq-6	0.0484 <sup>b</sup>	20	$9.68 \times 10^{-1}$
Aq-5 <sup>c</sup>	0.0484	20	$9.68 \times 10^{-1}$
Aq-4 <sup>c</sup>	0.0484	20	$9.68 \times 10^{-1}$
$\Sigma$ Strip #1	4.84	119	$5.76 \times 10^2$
$\Sigma$ Strip #2	282.27	15.3	$4.31 \times 10^3$

<sup>a</sup>Prepared by diluting 17.2  $\mu\text{L}$  of 282.27  $\mu\text{g/mL}$  stock to 1 mL with 5M  $\text{HNO}_3$ .

<sup>b</sup>Prepared by diluting 10  $\mu\text{L}$  of the 4.84  $\mu\text{g/mL}$  stock to 1 mL with 5M  $\text{HNO}_3$ .

<sup>c</sup>The sample size of  $^{239}\text{Pu}$  was not lowered beyond that of Aq-6, because the detection limit was not far below 1 ng/total sample.

#### (b) Analytical Measurement

The mass spectrometric analysis was performed by E. L. Callis (Analytical Chemistry Laboratory, Chemical Technology Division, Argonne National Laboratory).

Samples as delivered to the mass spectrometry laboratory were transferred to new clean beakers and evaporated to dryness to remove traces of volatile organic solvents. Sample Aq-4, having the smallest Pu content, was treated with perchloric acid to remove all traces of organic compounds. All samples were redissolved in 0.1 to 1 mL 0.8M nitric acid. Aliquots of the sample solutions containing 1 to 10 ng of Pu were loaded onto degassed Ta filaments, dried, and inserted into a mass spectrometer.

The  $^{242}\text{Pu}/^{239}\text{Pu}$  ratios in the spiked samples were measured on a single-stage mass spectrometer of NBS design (30-cm radius), equipped with a Faraday cup collector. For this work, triple-filament source geometry was used, with the rhenium-ionizing filament operated at 2060°C. The detection limit for plutonium isotopes using this system is approximately  $1 \times 10^{-12}$  g.

(5) Technetium Analysis

Technetium analysis of aqueous phases was performed by just extracting the pertechnetate ion from other radionuclides and colored species using 30 vol % Aliquat-336™ in xylene and measuring  $^{99}\text{Tc}$  in the resultant organic phase by liquid scintillation counting.

(a) Sample Preparation

Four milliliter aliquots from each of the seven raffinate solutions, the feed solution, and the E strip solution were diluted with an equal volume of water to decrease the acidity. (The decreased acidity enhances  $D_{\text{Tc}}$  and decreases  $D_{\text{Am}}$ ,  $D_{\text{Pu}}$ , and  $D_{\text{Np}}$ .) The resultant aqueous phases were contacted with 2 mL of 30% Aliquat-336™ nitrate in xylene followed by scrubbing twice with 4 mL of 0.5M  $\text{HNO}_3$ .

(b) Analytical Measurement

After the second scrub, a 0.100 mL aliquot of each organic phase was added to 10 mL of a Beckman HP grade scintillation cocktail and counted, along with blank samples for background determinations, for 50 minutes per sample or until the counting error was less than 2% (whichever occurred first). The feed sample was carried through the separation and counting process as a standard for quantitating the technique.

(6) Uranium Analysis

Uranium ion concentrations were measured by using laser excitation fluorescence spectrometry on a Scintrex Uranium Analyzer™. When the uranium concentration was high enough, the same solutions prepared for ICP/AES analysis could be used to measure uranium concentration. However, when the uranium concentration was low, interferences from other ions in solution made detection impossible, and uranium had to be separated from the gross constituents before its analysis.

(a) Sample Preparation

In the case of the aqueous phases from stages 5 and 6, the uranium concentration was below detectability due to interferences in the analysis from other ions in solution. Therefore, a preliminary separation of uranyl ion from the metal ion constituents of the waste solution had to be made to reduce interferences. This separation was performed by increasing the acidity of a 2 mL aliquot of 5-A and 6-A to 3M  $\text{HNO}_3$  and then extracting the uranyl ion with two successive half volumes of 30% TBP in dodecane. The combined organic phases were scrubbed three times with 4M  $\text{HNO}_3$ , having a O/A phase ratio of two, then stripped twice with half volumes of  $\text{H}_2\text{O}$  and twice with half volumes of 0.1M oxalic acid. The water and oxalic acid strips were combined in a 5 mL volumetric flask and diluted to volume with water. The TBP-dodecane solution was preconditioned using two equal volume scrubs with 0.25M  $\text{Na}_2\text{CO}_3$ -0.05M  $\text{Na}_2\text{C}_2\text{O}_4$  followed by two equal volume scrubs with 4M  $\text{HNO}_3$ .

Samples of organic phases from stages 7, 6, and 5 were stripped with two successive double volumes of water followed by two successive double volumes of sodium citrate. The combined strips were diluted to volume in a 25 mL volumetric flask. The resultant sample was used for uranium fluorescence analysis.

(b) Analytical Measurements

Uranium ion concentrations were measured by A. M. Essling (Analytical Chemistry Laboratory, Chemical Technology, ANL). Samples were either run as delivered or, if necessary, diluted to an appropriate concentration for measurement. The detection limit for measuring uranium ion in solution is 10 µg/L for 50 µL-size samples. For larger samples (<10 mL), the detection limit is in the range of 0.01 µg/L.

REFERENCES

HORWITZ

E. P. Horwitz and C. A. A. Bloomquist, Chemical Separations for Super-Heavy Element Searches in Irradiated Uranium Targets, J. Inorg. Nucl. Chem. 37, 425 (1975).

PEPPARD

D. F. Peppard, "Liquid-Liquid Extraction of Metal Ions," in Advances in Inorganic and Radiochemistry, Vol. 9, Academic Press Inc., New York (1966).

## APPENDIX C.

## OXALIC ACID COMPLEXING OF CAW AND DSW COMPONENTS

Oxalic acid is a diacidic compound that forms stable complexes with many metal ions. The metal ions most important to the chemistry of the TRUEX process are  $\text{Fe}^{3+}$ ,  $\text{Al}^{3+}$ , and  $\text{Zr}^{4+}$ . The mass balance equation for oxalic acid is:

$$[\text{H}_2\text{Ox}]_{\text{Total}} = [\text{H}_2\text{Ox}] + [\text{HOx}^-] + [\text{Ox}^{2-}] + [\text{FeOx}^+] + 2[\text{Fe}(\text{Ox})_2^-] +$$

$$[\text{AlOx}^+] + 2[\text{Al}(\text{Ox})_2^-] + [\text{ZrOx}^{2+}] + 2[\text{Zr}(\text{Ox})_2] \quad (\text{C-1})$$

Other metal ions in CAW or DSW do not greatly affect this mass balance because their concentrations and/or their propensity to form oxalate complexes are low.

Acid dissociation constants for oxalic acid and complex stability constants for oxalate complexes under flowsheet conditions were identified by roughly extrapolating the many reported values [PERRIN, MARTELL, SILLEN-1964, -1971, BJERRUM] to 40°C and high ionic strength. In this rough extrapolation, values out of line with the general trend were ignored. Activity values for hydrogen ion ( $h^0$ ) in nitric acid solutions were also taken from the literature [PAUL, DAY].

The relative concentrations of  $\text{H}_2\text{Ox}$ ,  $\text{HOx}^-$ , and  $\text{Ox}^{2-}$  in terms of the fraction of total uncomplexing oxalic acid in various nitric acid solutions are shown in Table C-1. These values were calculated from Eqs. C-2 to C-5 below:

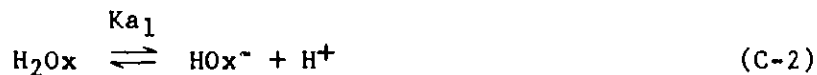

$$K_{a1} = [\text{H}^+][\text{HOx}^-]/[\text{H}_2\text{Ox}] = 0.10\text{M} \quad (\text{C-4})$$

$$K_{a2} = [\text{H}^+][\text{Ox}^{2-}]/[\text{HOx}^-] = 5.0 \times 10^{-4}\text{M} \quad (\text{C-5})$$

The  $h^0$  for each nitric acid solution and those predicted for CAW and DSW solution are also shown in Table C-1.

The data shown in Tables C-2 through C-5 are oxalate complex stability constants for metal ion species of importance to CAW and DSW. To approximate conditions of high ionic strength solutions at 40°C, these constants were treated in the same manner as the acidity constants were. The constants in these tables are defined by the following eight equations:



$$K_1 = [\text{M}(\text{Ox})^{z-2}] / [\text{M}^{z+}] [\text{Ox}^{2-}] \quad (\text{C-7})$$

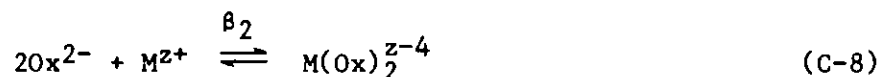

$$\beta_2 = [\text{M}(\text{Ox})_2^{z-4}] / [\text{M}^{z+}] [\text{Ox}^{2-}]^2 \quad (\text{C-9})$$

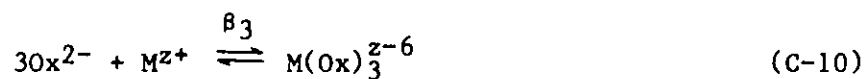

$$\beta_3 = [\text{M}(\text{Ox})_3^{z-6}] / [\text{M}^{z+}] [\text{Ox}^{2-}]^3 \quad (\text{C-11})$$

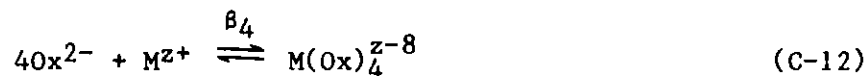

$$\beta_4 = [\text{M}(\text{Ox})_4^{z-8}] / [\text{M}^{z+}] [\text{Ox}^{2-}]^4 \quad (\text{C-13})$$

Table C-1. The Hydrogen Ion Activity ( $h^0$ ) and the Fraction of  $\text{H}_2\text{Ox}$ ,  $\text{HOx}^-$ , and  $\text{Ox}^{2-}$  for Uncomplexing Oxalic Acid in Various Nitric Acid Media

$[\text{HNO}_3]$ , <u>M</u>	$h^0$ , <u>M</u>	Fraction of Oxalic Acid		
		$\text{H}_2\text{Ox}$	$\text{HOx}^-$	$\text{Ox}^{2-}$
$8 \times 10^{-3}$	$8 \times 10^{-3}$	0.070	0.875	0.055
0.1	0.1	0.50	0.50	$2.5 \times 10^{-3}$
0.5	0.62	0.86	0.14	$1.1 \times 10^{-4}$
1.0	1.5	0.94	0.062	$2.1 \times 10^{-5}$
2.0	4.7	0.98	0.021	$2.2 \times 10^{-6}$
3.0	10.5	0.99	0.0094	$4.5 \times 10^{-7}$
4.0	19.5	0.995	0.0051	$1.3 \times 10^{-7}$
CAW (1 <u>M</u> $\text{HNO}_3$ )	4	0.98	0.024	$3.0 \times 10^{-6}$
DSW (1 <u>M</u> $\text{HNO}_3$ )	$\sim 2.1^a$	0.95	0.045	$1.1 \times 10^{-5}$

<sup>a</sup>Obtained by interpolation of  $h^0$  values for solutions containing 1M  $\text{HNO}_3$ , no additional nitrate, and 1M  $\text{HNO}_3$  and 3M total  $\text{NO}_3^-$ ; DSW is 1M  $\text{HNO}_3$  and contains 1.7M total nitrate.

Table C-2. Logarithms of Oxalato-Complex Stability Constants for Metal Ions in High Concentration in CAW and DSW

Metal Ion	K <sub>1</sub>	β <sub>2</sub>	β <sub>3</sub>
Al <sup>3+</sup>	7.0	12	16
Fe <sup>3+</sup>	7.5	14	19.2
Cr <sup>3+</sup>	5.3	10.5	15.6
Ni <sup>2+</sup>	5.2	7.7	8.4
Mo <sup>3+</sup>	1.6	-	-
MoO <sub>2</sub> <sup>2+</sup>	3.4	-	-
Zr <sup>4+</sup>	10.5	21	-

Table C-3. Logarithms of Oxalato-Complex Stability Constants for Actinide Element Species

Metal Ion	K <sub>1</sub>	β <sub>2</sub>	β <sub>3</sub>	β <sub>4</sub>
U <sup>4+</sup>	8.6	16.9	22.7	27.7
UO <sub>2</sub> <sup>2+</sup>	6.0	10.6	11.0	-
Np <sup>4+</sup>	8.6	16.8	23.5	27.4
NpO <sub>2</sub> <sup>+</sup>	3.7	6.7	-	-
NpO <sub>2</sub> <sup>2+</sup>	6.0	10.1	-	-
Pu <sup>4+</sup>	8.7	16.9	23.4	27.5
PuO <sub>2</sub> <sup>+</sup>	3.9	10.6	-	-
PuO <sub>2</sub> <sup>2+</sup>	6.7	11.4	-	-
Am <sup>3+</sup>	5	9	11	-

Table C-4. Logarithms of Oxalato-Complex Stability Constants for Lanthanide Elements and Yttrium Species

Metal Ion	K <sub>1</sub>	β <sub>2</sub>	β <sub>3</sub>	β <sub>4</sub>
Y <sup>3+</sup>	5.5	9.3	-	-
La <sup>3+</sup>	4.7	8.2	11	-
Ce <sup>3+</sup>	5	8	9	-
Nd <sup>3+</sup>	7.2	11.5	13	-
Sm <sup>3+</sup>	6.6	-	-	-
Eu <sup>3+</sup>	4.9	8.8	11.4	-
Gd <sup>3+</sup>	4.8	8.7	-	-
Tb <sup>3+</sup>	5.2	9.0	11.9	13.4

Table C-5. Logarithms of Oxalato Complex Stability Constants for Noble Metal Ion and Other Metal Ion Species

Metal Ion	K <sub>1</sub>	β <sub>2</sub>	β <sub>3</sub>
Ru <sup>3+</sup>	5	-	12.3
Pd <sup>2+</sup>	8.8	12.4	-
Ag <sup>+</sup>	<2	-	-
Cu <sup>2+</sup>	6	9.9	-
Be <sup>2+</sup>	4.3	5.5	-
Ca <sup>2+</sup>	2.5	3.0	-
Ba <sup>2+</sup>	0.6	-	-

Of the other three anionic species in solution ( $\text{NO}_3^-$ ,  $\text{SO}_4^{2-}$ , and  $\text{F}^-$ ), only fluoride, which has a significant concentration only in CAW, has any significant complexing ability. Table C-6 shows the stability data for fluoride complexes of the three metal ions which are also complexed by oxalate ion [HOGFELDT, MARTELL, SILLEN-1964, -1971, BJERRUM]. The acid dissociation constant for hydrofluoric acid was approximated from the same sources to be  $1 \times 10^{-3}\text{M}$ .

Table C-6. Logarithms for Fluoride Complex Stability Constants for Metal Ions in CAW and DSW

Metal Ion	$K_1$	$\beta_2$	$\beta_3$	$\beta_4$
$\text{Al}^{3+}$	6.7	12	15.9	19.2
$\text{Fe}^{3+}$	5.4	9.6	12	-
$\text{Zr}^{4+}$	9.0	16	22.1	27.5

A series of mass balance equations was set up for Zr, Fe, Al, F, and oxalic acid:

$$[\text{Zr}]_{\text{Total}} = [\text{Zr}^{4+}]_{\text{free}} + [\text{ZrOx}^{2+}] + [\text{Zr}(\text{Ox})_2] + [\text{ZrF}^{3+}] + [\text{ZrF}_2^{2+}] + [\text{ZrF}_3^+] + [\text{ZrF}_4] \quad (\text{C-14})$$

$$[\text{Al}]_{\text{Total}} = [\text{Al}^{3+}]_{\text{free}} + [\text{AlOx}^+] + [\text{Al}(\text{Ox})_2^-] + [\text{Al}(\text{OX})_3^{3-}] + [\text{AlF}_2^{2+}] + [\text{AlF}_2^+] + [\text{AlF}_3] + [\text{AlF}_4^-] \quad (\text{C-15})$$

$$[\text{Fe}]_{\text{Total}} = [\text{Fe}^{3+}]_{\text{free}} + [\text{FeOx}^+] + [\text{Fe}(\text{OX})_2^-] + [\text{Fe}(\text{OX})_3^{3-}] + [\text{FeF}_2^{2+}] + [\text{FeF}_2^+] + [\text{FeF}_3] \quad (\text{C-16})$$

$$[\text{F}]_{\text{Total}} = [\text{HF}] + [\text{F}^-] + [\text{ZrF}^{3+}] + 2[\text{ZrF}_2^{2+}] + 3[\text{ZrF}_3^+] + 4[\text{ZrF}_4] + [\text{AlF}_2^{2+}] + 2[\text{AlF}_2^+] + 3[\text{AlF}_3] + 4[\text{AlF}_4^-] + [\text{FeF}_2^{2+}] + 2[\text{FeF}_2^+] + 3[\text{FeF}_3] \quad (\text{C-17})$$



$$K_a = [\text{H}^+][\text{F}^-]/[\text{HF}] = 1 \times 10^{-3}\text{M} \quad (\text{C-19})$$



A second reaction

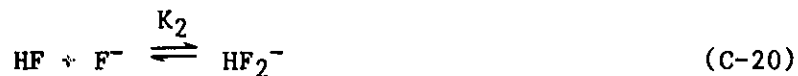

$$K_2 = [\text{HF}_2^-]/[\text{HF}][\text{F}^-] = 4\text{M}^{-1} \quad (\text{C-21})$$

is not important in CAW or DSW solutions because of the low concentrations of free fluoride ions and hydrofluoric acid due to the presence of stable fluoro-metal ion complexes.

Table C-7 shows sample results of calculating the species present in CAW solution at various oxalic acid concentrations. Under all conditions, most of the fluoride ion is tied up as  $\text{AlF}_2^+$ ; in the absence of oxalate ion, greater than 99% of the zirconium ion is tied up as fluoro-complexes. With a total oxalic acid concentration of 0.05M, however, the fluoro-complexes make up less than 0.5% of the total zirconium, and 99% of  $\text{Zr}^{4+}$  is present as  $\text{Zr}(\text{Ox})_2$ . At 0.2M total oxalic acid, 99.9% of Zr is present as the dioxalato-complex. In general, increasing the concentration of total oxalate in the CAW solution does not greatly affect the amount of iron or aluminum ion complexed with fluoride ion, but does greatly decrease the amounts of uncomplexed ions for both metals. Zirconium is almost quantitatively transformed from fluoro- to oxalato-complexes.

Table C-7. Speciation in CAW Solution (Oxalate<sub>Total</sub> = 0.2M, 0.1M, and 0.05M; HNO<sub>3</sub> = 1M, Al = 0.6M, Fe = 0.15M; F = 0.15M; Zr = 2.8x10<sup>-3</sup>M<sup>a</sup>)

Species Added	Species in Solution	H <sub>2</sub> Ox = 0.2M		H <sub>2</sub> Ox = 0.1M		H <sub>2</sub> Ox = 0.05M		H <sub>2</sub> Ox = 0	
		% of Added	Concentration, M	% of Added	Concentration, M	% of Added	Concentration, M	% of Added	Concentration, M
H <sub>2</sub> Ox	H <sub>2</sub> Ox	4.7	9.4 x 10 <sup>-3</sup>	3.8	3.8 x 10 <sup>-3</sup>	3.2	1.6 x 10 <sup>-3</sup>	-	-
	HOx <sup>-</sup>	0.31	6.2 x 10 <sup>-4</sup>	0.25	2.5 x 10 <sup>-4</sup>	0.22	1.1 x 10 <sup>-4</sup>	-	-
	Ox <sup>2-</sup>	1.5 x 10 <sup>-5</sup>	3.0 x 10 <sup>-8</sup>	1.2 x 10 <sup>-5</sup>	1.2 x 10 <sup>-8</sup>	1.0 x 10 <sup>-5</sup>	5.2 x 10 <sup>-9</sup>	-	-
F <sup>-</sup>	HF	6.7 x 10 <sup>-2</sup>	1.0 x 10 <sup>-4</sup>	5.9 x 10 <sup>-2</sup>	8.8 x 10 <sup>-5</sup>	5.6 x 10 <sup>-2</sup>	8.4 x 10 <sup>-5</sup>	4.7 x 10 <sup>-2</sup>	7 x 10 <sup>-5</sup>
	F <sup>-</sup>	5.5 x 10 <sup>-5</sup>	8.3 x 10 <sup>-8</sup>	4.7 x 10 <sup>-5</sup>	7.0 x 10 <sup>-8</sup>	4.5 x 10 <sup>-7</sup>	6.7 x 10 <sup>-8</sup>	4.1 x 10 <sup>-5</sup>	6.2 x 10 <sup>-8</sup>
Fe <sup>3+</sup>	Fe <sup>3+</sup>	48	0.072	71	0.111	84	0.13	98	0.148
	FeOx	47	0.070	27	0.041	14	0.021	-	-
	FeOx <sub>2</sub>	4	0.0065	1.0	0.001	-	-	-	-
	FeF	1	0.0015	1.3	0.002	1.4	0.002	1.5	0.0023
Al <sup>3+</sup>	Al <sup>3+</sup>	58	0.35	68	0.41	72	0.43	76	0.46
	AlOx	17	0.10	8.2	0.049	3.7	0.022	-	-
	AlOx <sub>2</sub>	0.05	0.0003	-	-	-	-	-	-
	AlF	24	0.14	24	0.14	24	0.14	24	0.14
	AlF <sub>2</sub>	0.3	0.002	0.3	0.002	0.3	0.002	0.3	0.002
Zr <sup>4+</sup>	Zr <sup>4+</sup>	1.1 x 10 <sup>-4</sup>	3.1 x 10 <sup>-9</sup>	6.9 x 10 <sup>-4</sup>	1.9 x 10 <sup>-8</sup>	3.7 x 10 <sup>-3</sup>	1.0 x 10 <sup>-7</sup>	0.96	2.7 x 10 <sup>-5</sup>
	ZrOx	0.11	3.0 x 10 <sup>-6</sup>	2.6 x 10 <sup>-1</sup>	7.4 x 10 <sup>-6</sup>	0.61	1.7 x 10 <sup>-5</sup>	-	-
	ZrOx <sub>2</sub>	99.9	2.8 x 10 <sup>-3</sup>	99.3	2.8 x 10 <sup>-3</sup>	99.0	2.77 x 10 <sup>-3</sup>	-	-
	ZrF	9.2 x 10 <sup>-3</sup>	2.6 x 10 <sup>-7</sup>	4.8 x 10 <sup>-2</sup>	1.4 x 10 <sup>-6</sup>	0.26	6.9 x 10 <sup>-6</sup>	59	1.7 x 10 <sup>-3</sup>
	ZrF <sub>2</sub>	7.7 x 10 <sup>-3</sup>	2.1 x 10 <sup>-7</sup>	3.4 x 10 <sup>-1</sup>	9.5 x 10 <sup>-6</sup>	0.16	4.6 x 10 <sup>-6</sup>	37	1.0 x 10 <sup>-3</sup>
	ZrF <sub>3</sub>	8.0 x 10 <sup>-4</sup>	2.2 x 10 <sup>-8</sup>	2.4 x 10 <sup>-2</sup>	6.8 x 10 <sup>-7</sup>	0.014	3.9 x 10 <sup>-7</sup>	2.9	8.0 x 10 <sup>-5</sup>
	ZrF <sub>4</sub>	1.7 x 10 <sup>-5</sup>	5 x 10 <sup>-10</sup>	5.2 x 10 <sup>-5</sup>	1.5 x 10 <sup>-9</sup>	2.3 x 10 <sup>-4</sup>	6.6 x 10 <sup>-9</sup>	4.8 x 10 <sup>-4</sup>	1.3 x 10 <sup>-6</sup>

<sup>a</sup>These calculations are based on an activity of hydrogen ion of 1.5M. According to the hydrogen ion activity data presented in Table C-1, this value should have been 4M. This mistake has had the effect of calculating slightly higher amounts of both oxalato- and fluoro-metal complexes and lower amounts of the species HF, H<sub>2</sub>Ox, and HOx<sup>-</sup>. General trends would remain the same.

## REFERENCES

## BJERRUM

J. Bjerrum, G. Schwarzenbach and L. G. Sillén, Stability Constants of Metal-Ion Complexes, With Solubility Products of Inorganic Substances, The Chemical Society, London (1958).

## DAY

J. S. Day and P. A. H. Wyatt, H<sup>0</sup> Measurements in Some Salt-Acid Mixtures of Fixed Total Anion Concentration, J. Chem. Soc. (B), 343 (1966).

## HOGFELDT

E. Hogfeldt, Stability Constants of Metal-Ion Complexes, Part A: Inorganic Ligands, IUPAC Chemical Data Series, No. 21, Pergamon Press, New York (1979).

## MARTELL

A. E. Martell, Stability Constants of Metal-Ion Complexes, Supplement No. 1, Special Publication No. 25. Part II. Organic Including Macrocyclic Ligands, The Chemical Society, London (1971).

## PAUL

M. A. Paul and F. A. Long, H<sub>0</sub> and Related Indicator Acidity Functions, Chem. Rev. 52, 1 (1957).

## PERRIN

D. D. Perrin, IUPAC Chemical Data Series - No. 22, Stability Constants of Metal-Ion Complexes, Part B. Organic Ligands, Pergamon Press, New York (1979).

## SILLÉN-1964

L. G. Sillén and A. E. Martell, Stability Constants, Special Publication #17, The Chemical Society, London (1964).

## SILLÉN-1971

L. G. Sillén, Stability Constants of Metal-Ion Complexes, Supplement No. 1, Special Publication No. 25, Part I. Inorganic Ligands, The Chemical Society, London (1971).

Distribution for ANL-84-45Internal:

E. S. Beckjord	R. A. Leonard (15)
D. L. Bowers	E. P. Steinberg
L. Burris	M. J. Steindler (5)
F. A. Cafasso	G. F. Vandegrift (15)
S. L. Gawenda	ANL Patent Dept.
B. M. Grazis (5)	ANL Contract File
D. R. Hamrin	ANL Libraries
J. E. Harmon	TIS Files (6)
E. P. Horwitz (15)	

External:

DOE-TIC, for distribution per UC-10 and -70 (380)  
 Manager, Chicago Operations Office, DOE  
 S. A. Mann, DOE-CH  
 Chemical Technology Division Review Committee Members:

- S. Baron, Burns and Roe, Inc., Oradell, N. J.
- R. Winston, U. Chicago
- C. J. Ambrose, Westinghouse-Hanford Co.
- G. S. Barney, Rockwell Hanford Operations
- G. E. Benedict, General Atomic Co.
- B. C. Blanke, USDOE-DA, Miamisburg, O.
- W. D. Bond, Oak Ridge National Lab.
- D. Bowersox, Los Alamos National Lab.
- J. L. Burnett, Office of Basic Energy Sciences, USDOE
- G. A. Burney, Savannah River Lab.
- G. R. Choppin, Florida State U.
- C. E. Coffey, Savannah River Lab.
- F. E. Coffman, Office of Terminal Waste Disposal and Remedial Action, USDOE
- C. R. Cooley, Jr., Div. of Waste Repository Deployment, USDOE
- D. J. Crouse, Oak Ridge National Lab.
- R. Cunningham, Nuclear Materials Safety and Safeguards, USNRC
- G. H. Daly, Office of Dep. Asst. Secy. for Nuclear Materials, USDOE
- J. T. D'Ambrosia, Div. of Defense Waste and Byproducts Management, USDOE
- B. R. Dickey, Exxon Nuclear Corp., Idaho Falls
- O. J. Elgert, Richland Operations Office, USDOE
- E. S. Goldberg, Savannah River Operations Office, USDOE
- A. P. Gouge, Savannah River Lab.
- W. S. Groenier, Oak Ridge National Lab.
- H. D. Harmon, Savannah River Lab.
- T. B. Hindman, Jr., Savannah River Operations Office, USDOE
- M. E. Hodges, Savannah River Lab.
- L. J. Jardine, Bechtel National, Inc., San Francisco
- A. S. Jennings, Savannah River Lab.
- J. J. Jicha, Div. of Defense Waste and Byproducts Management, USDOE
- B. F. Judson, General Electric Uranium Management Corp., Sunnyvale
- C. J. Kershner, Mound Lab.
- R. Lambert, Electric Power Research Inst., Palo Alto
- Los Alamos National Lab., Director
- Los Alamos National Lab., Librarian
- R. Y. Lowery, Albuquerque Operations Office, USDOE

R. Maher, Savannah River Plant  
J. C. Mailen, Oak Ridge National Lab.  
D. L. McIntosh, Savannah River Lab.  
W. H. McVey, Div. of LMFBR Fuel Cycle Projects, USDOE  
E. Michaels, Mound Lab.  
A. C. Muscattello, Rockwell International, Golden  
J. D. Navratil, Rockwell International, Golden  
E. D. North, Oak Ridge National Lab.  
D. A. Orth, Savannah River Lab.  
B. Paige, Exxon Nuclear Corp., Idaho Falls  
J. H. Pashley, Oak Ridge Gaseous Diffusion Plant  
E. S. Pierce, Office of Basic Energy Sciences, USDOE  
H. Ramsey, Los Alamos National Lab.  
D. J. Reif, Savannah River Lab.  
A. D. Ryon, Oak Ridge National Lab.  
W. W. Schulz, Rockwell Hanford Operations (20)  
F. D. Stevenson, Office of Basic Energy Sciences, USDOE  
K. Street, Lawrence Livermore National Lab.  
D. W. Tedder, Georgia Inst. Technology  
M. C. Thompson, Savannah River Lab.  
USDOE Office of Spent Fuel Management and Reprocessing Systems, LMFBR Fuel  
Cycle Projects  
USDOE Office of Basic Energy Sciences  
H. H. Van Tuyl, Battelle Pacific Northwest Lab.  
V. C. A. Vaughn, Oak Ridge National Lab.  
E. E. Voiland, General Electric Co., Morris, Ill.  
R. D. Walton, Jr., Office of Defense Waste and Byproducts Management, USDOE  
M. E. Whatley, Oak Ridge National Lab.  
J. B. Whitsett, Idaho Operations Office, USDOE  
A. K. Williams, Bechtel National, Inc., San Francisco  
D. D. Wodrich, Rockwell Hanford Operations  
R. G. Wymer, Oak Ridge National Lab.