

University of New Hampshire

University of New Hampshire Scholars' Repository

Doctoral Dissertations

Student Scholarship

Winter 1983

TRUSS ANALYSIS USING SINGULAR IMBEDDING METHOD

THIEM JENNGAMKUL

University of New Hampshire, Durham

Follow this and additional works at: <https://scholars.unh.edu/dissertation>

Recommended Citation

JENNGAMKUL, THIEM, "TRUSS ANALYSIS USING SINGULAR IMBEDDING METHOD" (1983). *Doctoral Dissertations*. 1411.

<https://scholars.unh.edu/dissertation/1411>

This Dissertation is brought to you for free and open access by the Student Scholarship at University of New Hampshire Scholars' Repository. It has been accepted for inclusion in Doctoral Dissertations by an authorized administrator of University of New Hampshire Scholars' Repository. For more information, please contact Scholarly.Communication@unh.edu.

INFORMATION TO USERS

This reproduction was made from a copy of a document sent to us for microfilming. While the most advanced technology has been used to photograph and reproduce this document, the quality of the reproduction is heavily dependent upon the quality of the material submitted.

The following explanation of techniques is provided to help clarify markings or notations which may appear on this reproduction.

1. The sign or "target" for pages apparently lacking from the document photographed is "Missing Page(s)". If it was possible to obtain the missing page(s) or section, they are spliced into the film along with adjacent pages. This may have necessitated cutting through an image and duplicating adjacent pages to assure complete continuity.
2. When an image on the film is obliterated with a round black mark, it is an indication of either blurred copy because of movement during exposure, duplicate copy, or copyrighted materials that should not have been filmed. For blurred pages, a good image of the page can be found in the adjacent frame. If copyrighted materials were deleted, a target note will appear listing the pages in the adjacent frame.
3. When a map, drawing or chart, etc., is part of the material being photographed, a definite method of "sectioning" the material has been followed. It is customary to begin filming at the upper left hand corner of a large sheet and to continue from left to right in equal sections with small overlaps. If necessary, sectioning is continued again—beginning below the first row and continuing on until complete.
4. For illustrations that cannot be satisfactorily reproduced by xerographic means, photographic prints can be purchased at additional cost and inserted into your xerographic copy. These prints are available upon request from the Dissertations Customer Services Department.
5. Some pages in any document may have indistinct print. In all cases the best available copy has been filmed.

**University
Microfilms
International**

300 N. Zeeb Road
Ann Arbor, MI 48106

Jenngamkul, Thiem

TRUSS ANALYSIS USING SINGULAR IMBEDDING METHOD

University of New Hampshire

PH.D. 1983

**University
Microfilms
International** 300 N. Zeeb Road, Ann Arbor, MI 48106

TRUSS ANALYSIS USING
SINGULAR IMBEDDING METHOD

BY

Thiem Jenngamkul
B.Eng.(C.E.) Chulalongkorn University,
Bangkok, THAILAND, 1972
M.S.C.E. Youngstown State University, 1980

DISSERTATION

Submitted to the University of New Hampshire
in Partial Fulfillment of
the Requirements for the Degree of

Doctor of Philosophy
in
Engineering

December, 1983

This dissertation has been examined and approved



Dissertation director, Charles H. Goodspeed
Associate Professor of Civil Engineering

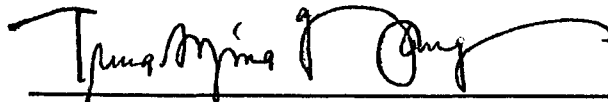

Tung-Ming Wang
Professor of Civil Engineering



Paul J. Ossenbruggen
Associate Professor of Civil Engineering

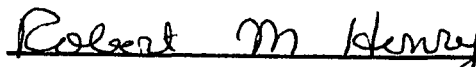

Robert M. Henry
Assistant Professor of Civil Engineering

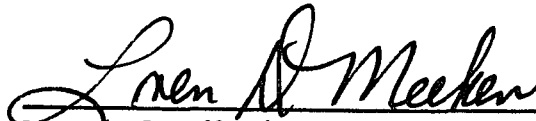

Loren D. Meeker
Professor of Mathematics

Sept. 16, 1983
Date

ACKNOWLEDGEMENTS

The author wishes to express his sincere gratitude and deep appreciation to his advisor, Dr. Charles H. Goodspeed, whose time, advice, and guidance contributed throughout the years that he was a graduate student.

He also wishes to thank Dr. Tung-Ming Wang, Dr. Paul J. Ossenbruggen, Dr. Robert M. Henry and Dr. Loren D. Meeker for giving their valuable time toward the completion of the requirement of this thesis.

He would like to thank Mrs. Patricia A. Shalhoob for assisting and consulting with his language. Finally, he would also like to thank the University of New Hampshire for financing his graduated study.

TABLE OF CONTENTS

	PAGE
ACKNOWLEDGEMENTS	iii
NOMENCLATURE	vi
GLOSSARY	ix
LIST OF TABLES	xii
LIST OF FIGURES	xiii
ABSTRACT	xv
CHAPTER	
1. INTRODUCTION	1
1.1 Historical Review	1
1.2 Singular Imbedding Method	2
1.3 Thesis Purpose	6
2. EQUATIONS OF SINGULAR IMBEDDING ANALYSIS ...	8
2.1 Fundamentals Of Network Analysis	8
2.2 Singular Systems	26
2.3 Singular Structural Imbedding	35
2.4 Nodal Equations For DC And FC Systems .	43
2.5 Variable Members In Problems	45
3. EQUALITY CONSTRAINTS	47
3.1 Types Of Constraints	47
3.2 Displacement Constraints	52
3.3 Force Constraints	65

	PAGE
3.4 Stress Constraints	77
4. ANALYSIS LIMITATIONS	87
4.1 Types Of Solutions	87
4.2 Feasible Solutions	88
4.3 Non-Feasible Solutions	90
5. DISCUSSIONS AND CONCLUSIONS	92
5.1 Discussions	92
5.2 Conclusions	93
APPENDIX A : COORDINATE TRANSFORMATIONS	97
APPENDIX B : ALGEBRAIC PROPERTIES OF NETWORKS	98
APPENDIX C : DESIGN AID FOR FRAMED STRUCTURE:	
SINGULAR IMBEDDING APPROACH	100
BIBLIOGRAPHY	107

NOMENCLATURE

- A = Member cross-sectional area
- [A] = A branch-node incidence matrix associated with the geometry transformation in global coordinates
- [A_g] = The branch-node incidence matrix associated with a geometry transformation of the variable members
- b = Number of branches
- c = Number of displacement constraints
- d = 2+2v
- e = 2+4v
- E = Modulus of elasticity
- F = Member forces
- H = Horizontal forces at the joints
- [I] = A unit matrix
- [K] = Member stiffness matrix or global unstructured stiffness matrix
- [K]_m = The local member stiffness matrix for member m
- [K]_m = A structural global stiffness matrix associated with DC
- [K]_n = A structural global stiffness matrix associated with FC
- L = Length of member
- {M} = The unknown variable matrix $\begin{Bmatrix} P_g \\ \vdots \\ u \end{Bmatrix}$

- n = Number of nodes or number of degrees of freedom
 N_j = Number of joints
 N_m = Number of members
 $\{N\}$ = The unknown variable matrix $\begin{Bmatrix} P_i \\ u \end{Bmatrix}$
 $\{P\}$ = The forces in global coordinates due to applied joint loads or a vector of applied joint loads in global coordinates
 $\{P'\}$ = The applied joint loads in global coordinates
 $\{P_g\}$ = The applied member forces of the variable members in local coordinates
 $\{R\}$ = The total member forces or the axial member forces in global coordinates
 $[S]$ = A structured global stiffness matrix
 $[T]$ = The transformation of displacement-rotation matrices for the members
 $[\tilde{T}]$ = A geometry transformation matrix
 u = The unknown member distortions in global coordinates
 $\{u\}$ = A vector of joint displacements in global coordinates
 $\{u'\}$ = Joint displacements
 $\{U\}$ = The member distortions due to discontinuities
 v = Number of variable members
 V = Vertical forces at the joints
 $\{V\}$ = The final member distortions in global coordinates
 $\{W\}$ = A column matrix represents joint loads including

constrained values in global coordinates

$\{W_1\}$ = A column matrix represents applied joint loads in global coordinates

$\{W_2\}$ = An applied joint load due to the force constraint in a variable member in global coordinates

$[0]$ = A null matrix

σ = Axial stresses in members

Δ = Member displacements

$\{\alpha\}$, $\{\beta\}$, $\{\delta\}$, $\{\mu\}$ = The resulting submatrices after transformation

Superscripts :

t,T = Matrix transposition

* = Local coordinates values

GLOSSARY

- Across Variable** = A joint displacement in the structural model, it can be measured by using strain gauges and defined as a vector quantity between two nodes.
- Branch** = A line connecting two nodes in the network graph. It represents a structural member. Associated with the branch is the member stiffness matrix relationship.
- Datum Node** = The node in a network graph that represents the structural supports (i.e., zero displacement, it is called reference node or fixed node)
- Ideal Load** = The applied load at the negative end of an ideal member in a DC system, it is a function of the displacement constraining value. In a FC system it is referred to as an applied member force. The magnitude represents the force constraints.
- Ideal Member** = A member with an assumed stiffness connected in series with a nullator used

- in a DC system.
- Joint** = It is defined as the connection of structural members and represented by the graph nodes.
- Member** = It is defined as the structural member and is represented by the graph branches
- Mesh/Loop** = If the starting and terminal nodes of a set of branches are the same node, it is called a mesh or a closed loop.
- Node** = The points in a network graph at the junction of the branches.
- Norator** = It is an element that is connected in series between the negative end and the new node in a FC system. In terms of force and displacement, it is defined as a Norator $(F,0)$.
- Nullator** = Member used to indicate the constrained relationship between the positive and negative ends in a DC system. The stiffness of this member is undefined.
- Through Variable** = A member force in a structural model, it can be calculated from the strain gauges and defined as a vector quantity at a node.
- Variable Member** = It is a member with unknown properties; for truss it is the cross-sectional

area. On the network graph, it is shown as a dashed line. In unstructured global stiffness matrix is treated to be zero for variable member.

LIST OF TABLES

TABLE	PAGE
1. Branch-Node Incidence Matrix	10
2. Simulation Of Network Model	
To Structural Model	19
3. Displacement Constraints	
Controlling Conditions	54
4. Force Or Stress Constraints	
Controlling Conditions	65

LIST OF FIGURES

FIGURE	PAGE
1. Illustrated Example Of A DC Constraint	5
2. Network Graph	9
3. Network Graph For Truss Problem	9
4a. Deformation Of Bar ij	11
4b. Joint Displacements Of Truss	11
5. Deformation Of A Part Of Truss	13
6. External And Internal Forces Of Truss	15
7a. Forces And Displacements At The Joints In Global Coordinates	21
7b. Forces And Displacements For Member m In Local Coordinates	21
8. DC System	27
9. DC System And A Part Of Network Graph	28
10. FC System	30
11. Network Graph With DC System	31
12. Network Graph With FC System	33
13. Structural Stiffness Matrix For Adding DC	36
14. Structural Stiffness Matrix For Adding FC	39
15. Examples Of Planar Truss Problems	42
16. Truss And Equivalent Of Network Graph	48
17. Adding DC To Constrain Displacement Δx	50

FIGURE	PAGE
18. Adding FC To Constrain Member Force Q	51
19. Deformation Shape	89
20. Superposition Method Of Deformation	90

ABSTRACT

TRUSS ANALYSIS USING SINGULAR IMBEDDING METHOD

by

THIEM JENNGAMKUL

University of New Hampshire, December, 1983

In structural analysis and design of trussed structures, the Singular Imbedding Method is applied and formulated to handle joint displacement, member force, and member stress constraints. There are two structural systems, namely, a Displacement Constraining System (DC) and a Force Constraining System (FC) that are developed for constraining joint displacements and member forces, respectively. The formulation of this method is based upon three sets of equations; equilibrium conditions, compatibility relationships, and Hooke's law of material.

The final structural stiffness matrix equations are constructed for the different types of constraints. The unknown member areas are determined from the final structural stiffness matrix equations. The analysis limitations are presented and classified for a design criterion. Example problems are presented to illustrate the application of this analysis.

CHAPTER 1

INTRODUCTION

1.1 Historical Review

The network topological technique is a method used to analyze elastic structural systems utilizing concepts similar to electrical circuit theory. This method was introduced by William R. Spillers,^(15,16) using network analysis principles, to develop mathematical models of truss problems. This mathematical analogy is convenient for solutions using a digital computer. A method of solution for an arbitrary truss is developed and written in terms of three matrices : one that describes the stiffness of the members; one that describes the loads on the joints; and an incidence matrix that represents the connectivity relations of the structure.

Network analysis of structures was developed by William R. Spillers and Frank L. Di Maggio,⁽¹⁷⁾ and by S.J. Fenves and F.H. Branin, Jr.^(6,7,8) Each investigated the following two methods of a network analysis : the node and

* Number in parenthesis refers to literature cited in the Bibliography

mesh methods which are similar to the displacement and force methods of structural analysis, respectively.

Matrix methods can be used to analyze and design statically indeterminate structures with specified constraints (e.g., joint displacements, member forces or member stresses). Initial values for structural properties are assumed and then modified during each iteration until a feasible solution is reached.

To eliminate the long process of iteration as previously described, the Singular Imbedding Method was introduced in structural analysis (See Appendix C). This approach was implemented for designing structures to meet specified requirements, namely, joint displacements or member forces.⁽¹⁴⁾ These requirements can be the constraints placed upon a problem by a designer or the limits specified by codes or other specifications.

1.2 Singular Imbedding Method

The Singular Imbedding Method was introduced by E.B. Kozemchak and M.A. Murray-Lasso for computer-aided circuit design.⁽¹²⁾ This method is a direct solution for designing the circuit elements to meet a given set of node-pair voltages, branch currents, or driving point and transfer impedances. The undetermined element currents, node voltages, resistors and capacitors are selected as the variables in the formulation. The singular elements

are introduced and connected into a network to impose the desired constraints. A voltage forcing element (VFE) is used to constrain network voltages, and a current forcing element (CFE) is used to constrain network currents. A final nodal equation is established and the values for the variable elements are solved simultaneously.

To analyze structural problems, a Network-Topological Formulation can be used. A network graph is used to represent the structural joints and members in a structural stiffness analysis. The graph nodes represent the structural joints and the graph branches correspond to the members. To extend the analysis to handle joint displacement and member force constraints DC (Displacement Constraining) and FC (Force Constraining) systems are developed. The systems when introduced into the analysis allows for the determination of member properties to achieve the structural performance specified by the constraints.

The following example will illustrate the procedure. Beginning with a structure with defined geometry and defined member properties for members a and b a displacement constraint is specified as shown in Figure (1a). A constraint is imposed that limits the free joint displacement in the x direction to have a magnitude of Δx . For the purpose of this example, member c is selected as the variable member. A DC system is introduced in place of member c as shown in Figure (1b). A stiffness analysis

is performed with the DC system. From this, the joint displacements and member forces are determined. The member stiffness equation for member c is then used to determine the variable member property for member c . For a truss structure the variable can be the cross-sectional area or the modulus of elasticity. This procedure may produce a positive or negative value for the variable property. A positive value represents a feasible solution. In other words if the magnitude of the variable property was used in the analysis the constraint would be satisfied. If the variable property is negative it represents a non-practical solution. This means that the specified constraint can not be achieved. This would occur if the specified constraint could not be physically achieved with any value for the variable property. An example of this is, if the specified displacement constraint exceeded the displacement in the structure without member c present as shown in Figure (1c). A possible way to achieve the constraint would be to prestress the variable member using the magnitude of the member force determined in the analysis and the determined value for the variable parameter. This type of solution is referred to in this thesis as a non-practical solution. If it is physically impossible to achieve the constraint condition, the method leads to a non-feasible solution.

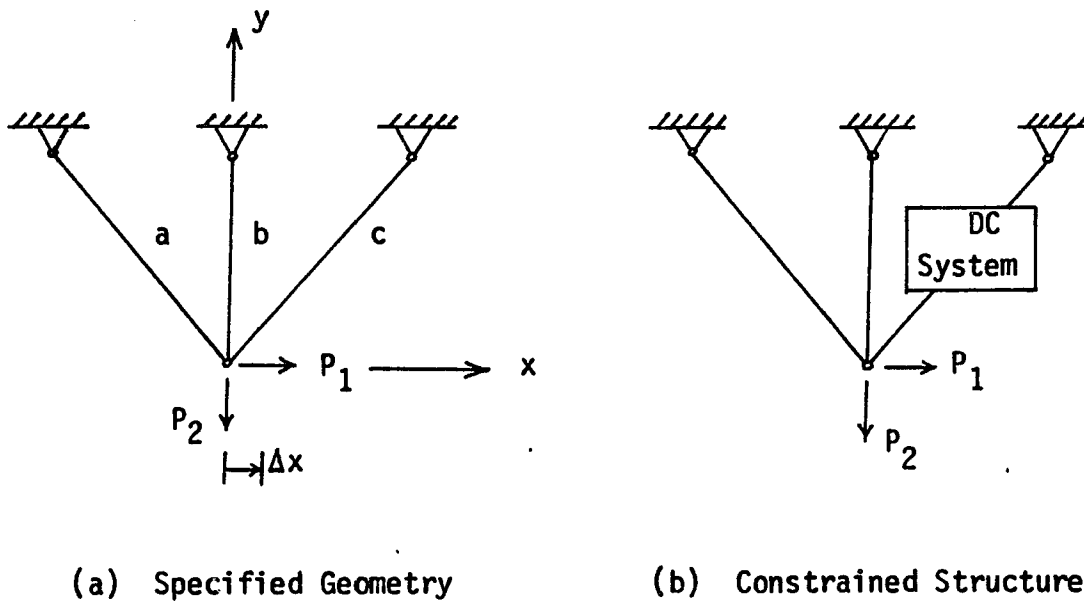

FIG.1 Illustrated Example Of A DC Constraint

A force constraint is handled similar to the displacement constraint. The structure is specified as illustrated for the displacement constraint and selected member or members are designated as being constrained to a magnitude of force. An FC system is introduced in place of the constrained member or members and a stiffness

analysis performed. The member stiffness equation is then used to determine a constrained member property. The equation is repeated for each constrained member. The results may be practical or non-practical solution as explained for the displacement constraint. Prestressing is required when the given loads do not develop the member force specified by the constraint.

1.3 Thesis Purpose

The purpose of this thesis is to formulate an analysis method to handle joint displacement, member force, and member stress constraints. The problems that are considered in this work are the design of elastic trusses. Two structural systems, a Displacement Constraining System (DC) and a Force Constraining System (FC), are developed for constraining joint displacements and member forces, respectively. These systems are added into a network graph which causes the structural stiffness matrix to become singular (a matrix that can not be inverted). Therefore, this method is called the Singular Imbedding Method. The three sets of equations used by this method (for linear elastic trusses) are :

(a) Equilibrium; the summation of forces at each node is equal to zero.

(b) Compatibility; the summation of displacements in a closed loop is equal to zero.

(c) Hooke's law; forces are associated with displacements as a function of the material properties in each member.

The final nodal equations are based upon these equations modified to handle the singularity and then solved simultaneously. The Singular Imbedding approach and the analysis limitations are investigated. The application of this analysis is shown by examples.

CHAPTER 2

EQUATIONS OF SINGULAR IMBEDDING ANALYSIS

2.1 Fundamentals Of Network Analysis

When a system is modeled as a network graph, the physical components of the system are superimposed on the network graph :

(i) The physical relationship of each component of the network graph depends upon the properties of a particular system being modeled, such as a truss, an electrical network, etc.

(ii) The interconnection of the components for the system is represented by the topology of the network, i.e., the interconnection between components.

Let us consider a network graph; the points are called nodes and the lines are called branches. A branch has two endpoints, each of which is a node. A node and a branch are said to be incident with each other if the node is an endpoint of the branch. In a structural problem, a branch represents a structural member. Associated with the branch is the member stiffness matrix relationship which for a truss is in linear form. Therefore, a branch in the network graph is defined as a linear function.⁽¹³⁾ A

linear graph is a collection of branches, each of which can have a common point with another branch only at a node. The topology of a graph describes the interconnection of the nodes. If the starting and terminal nodes of a set of branches are the same node, it is called a mesh or a closed loop, as shown in Fig.2(a).

A directed graph is one in which each branch is assigned a direction. A branch is oriented in the direction from its initial node to its final node. The initial node is defined to be positively incident on the branch and the final node negatively incident, as shown in Fig.2(b).

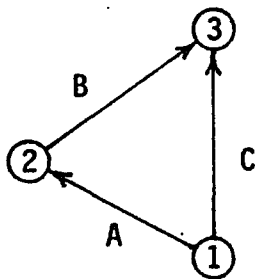

(a) Mesh

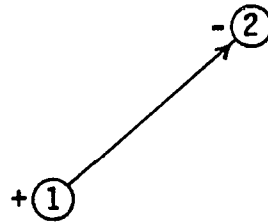

(b) Directed Branch

FIG. 2 Network Graph

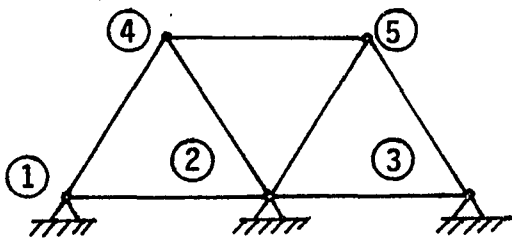

(a)

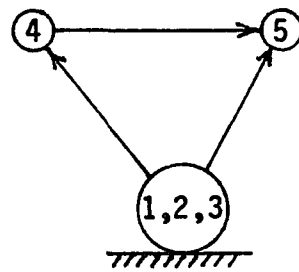

(b)

FIG. 3 Network Graph For Truss Problem

The incidence relationships between nodes and branches of a directed graph are specified by the branch-node incidence matrix. The elements of this matrix are defined as follows : $a_{ij} = (+1, -1, 0)$ if the i -branch is (positively, negatively, not) incident on the j -node. The size of this matrix is reduced by selecting one node of a graph as a datum or reference node. In most structures problem, all support nodes are taken as the datum point (as shown in Figure 3). For example, node 1 in Fig.2(a) is selected as a datum node, the branch-node incidence matrix is given in Table 1.

Table 1

Branch-Node Incidence Matrix

Node \ Branch	1	2	3
A		-1	0
B		1	-1
C		0	-1

$$[A]_{b \times (n-1)} = \begin{bmatrix} -1 & 0 \\ 1 & -1 \\ 0 & -1 \end{bmatrix}$$

b = number of branches

n = number of nodes

Considering the network stiffness (or node) method, the two types of variables are an "across" variable, obeying the continuity law, and a "through" variable, obeying equilibrium. An across variable (a joint displacement in the structural model) can be measured by using strain gauges and defined as a vector quantity between two nodes. Similarly, a through variable (a member force in structural model) can be calculated from the strain gauges and defined as a vector quantity at a node.

(4a) Deformation Of Bar ij 

FIG. (4b) Joint Displacements Of Truss

To begin the network problem, an arbitrary number is assigned to each node and branch of the graph. Figure (4a) depicts the deformation of bar ij , the elongation components of this bar in global coordinates are Δx (equals $l_1 - l_3$) and Δy (equals $l_2 - l_4$). These elongations are defined in terms of the member distortions for member ij . The translations of nodes i and j are called the joint displacements, i.e., Δx_i , Δy_i , Δx_j and Δy_j .

Let the unknown member distortions specified in global coordinates be denoted as u where $u = \{ \Delta x, \Delta y \}$. u' is defined as the applied nondatum joint displacements. From Figure (4b), the vector u' of node 3 is represented by Δx_3 and $-\Delta y_3$. The induced member distortions are specified by the matrix equation :

$$\{u\} = [A]\{u'\} \quad (2-1)$$

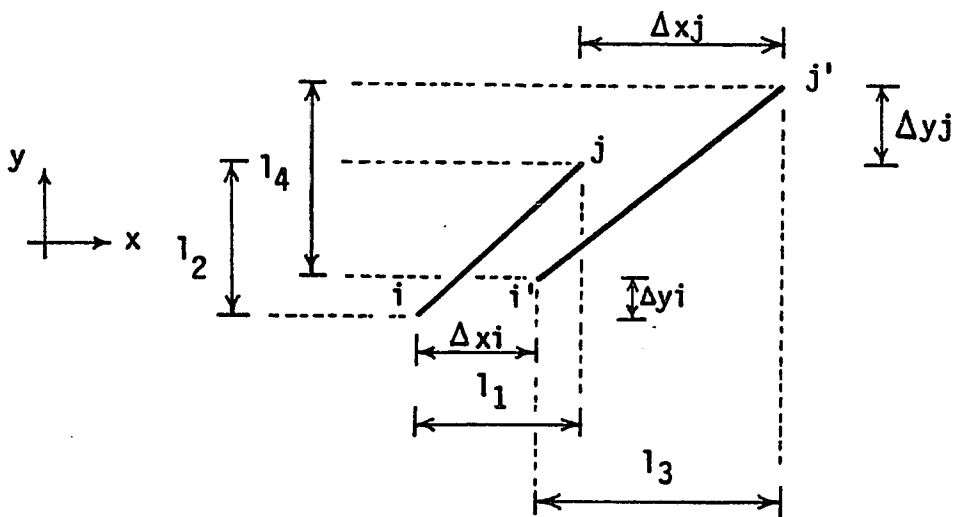
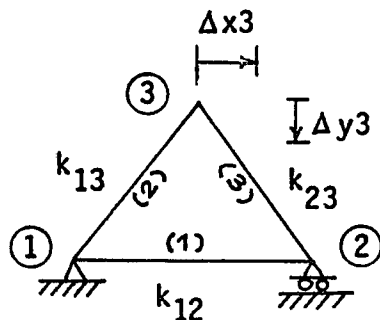
where

$\{u\}$ = the unknown member distortions in global coordinates, (2×1)

$[A]$ = a branch-node incidence matrix associated with the geometry transformation in global coordinates, $[2 \times (2n-1)]$

$\{u'\}$ = the assigned non-datum joint displacements in global coordinates, $[(2n-1) \times 1]$

The values of matrix $[A]$ in Table 1 are the

branch-node relationships. In a structural model, one node represents the displacements in x and y coordinates for a plane truss structure. Therefore, the values of 1, or -1, or 0 are associated with two joint displacements. From Equation (2-1), this relationship is applied to member ij in Figure (4a). Hence :

$$\begin{Bmatrix} \Delta x \\ \Delta y \end{Bmatrix} = [1 \quad -1] \begin{Bmatrix} \Delta x_i \\ \Delta y_i \\ \Delta x_j \\ \Delta y_j \end{Bmatrix} \quad (2-2)$$

Matrix $\{u\}$ must be defined in global coordinates before applying to Equation (2-1). The size of this matrix is equal to the number of degrees of freedom, determined as a function of the number of branches and nodes in the structure.

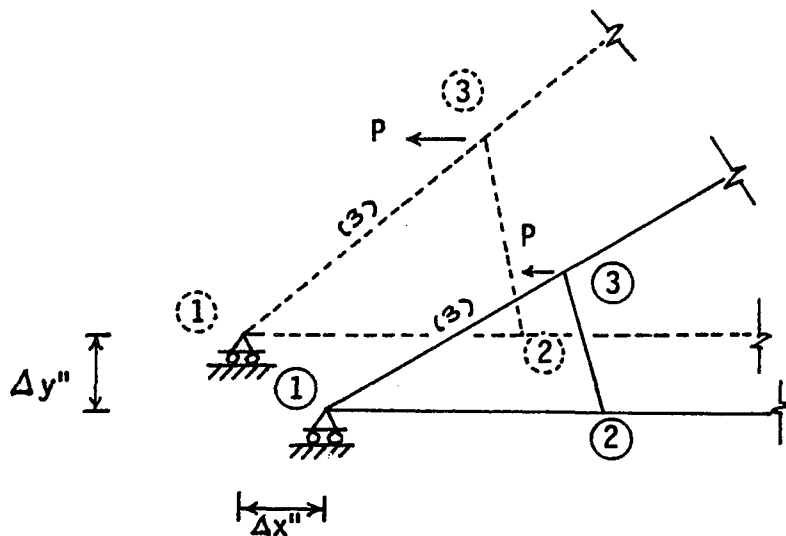

FIG. 5 Deformation Of A Part Of Truss

Generally, it is possible to assign to each branch discontinuity distortions (U) in addition to joint load induced member distortions (u) all distortions are in global coordinates. The discontinuity distortions are due to a movement of a support as shown in Figure 5, e.g., {U} is equal to { $\Delta x''$, $\Delta y''$ }. Therefore, the sum of the member applied and load induced vector quantities are now defined as :

$$\{V\} = \{u\} + \{U\} \quad (2-3)$$

where

{V} = the final member distortions in global coordinates, (2bx1)

{U} = the member distortions due to discontinuities, (2bx1)

From Equation (2-3), an example of this relationship is shown for member 3 in Figure 5, is :

$$\{\Delta x', \Delta y'\}^T = \{\Delta x, \Delta y\}^T + \{\Delta x'', \Delta y''\}^T \quad (2-4)$$

where

$$\{V\} = \{\Delta x', \Delta y'\}^T$$

{u} = { Δx , Δy }^T as described for member ij in Figure (4a).

Substituting Equation (2-1) into Equation (2-3) and assuming no discontinuities ($\{U\} = \{0\}$), yields :

$$\{V\} = [A]\{u\} \quad (2-5)$$

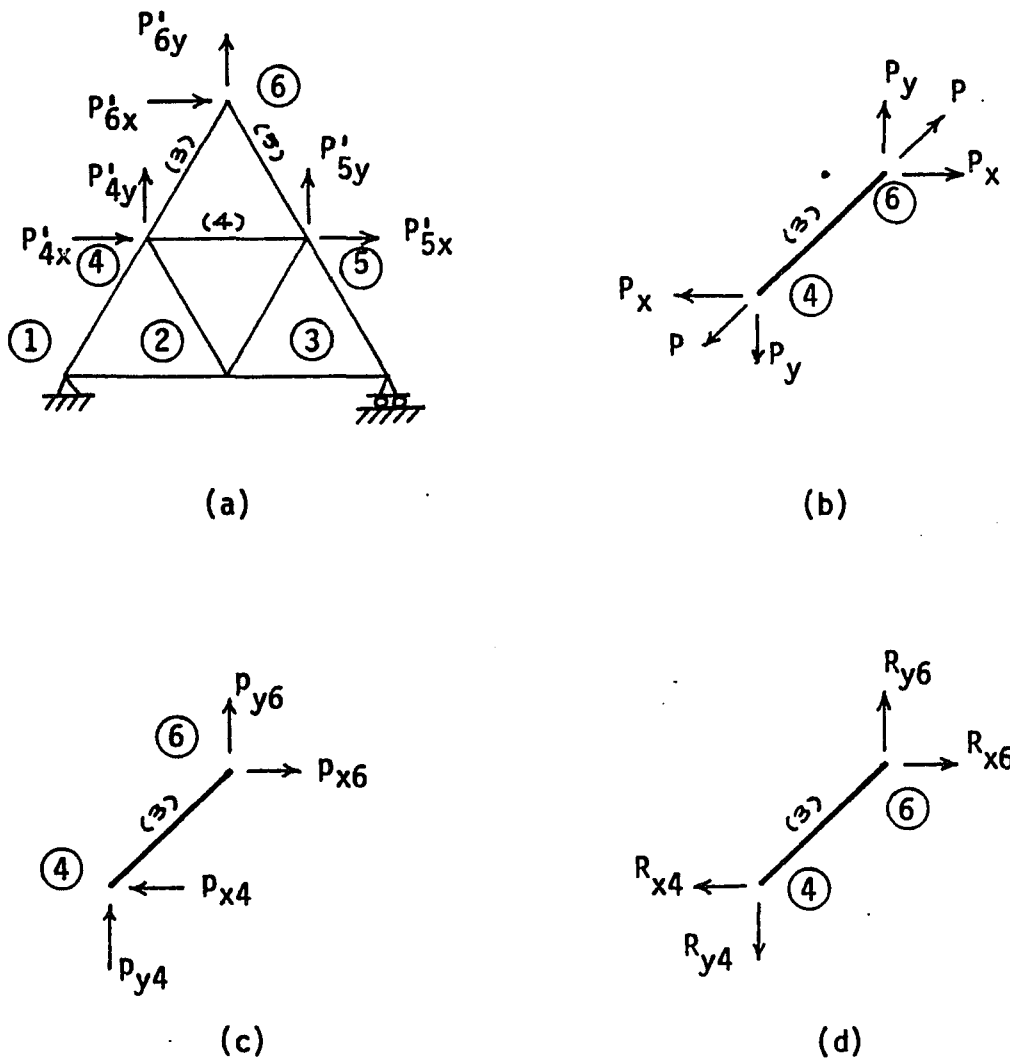

FIG. 6 External And Internal Forces Of Truss

Figure 6. depicts the external and internal forces of a truss. The applied joint loads P' at nodes 4, 5, and 6 are P'_{4x} , P'_{4y} , P'_{5x} , P'_{5y} , P'_{6x} , and P'_{6y} as shown in Figure

(6a). Let P be a force due to an applied load in member 3 shown in Figure (6b). This force can be shown as P_x and P_y in global coordinates. For member 4 and member 5, there are member forces similar to member 3, i.e., P_{x4} , P_{y4} , P_{x6} , and P_{y6} , as shown in Figure (6c). Due to Equation (39) from reference No. 6 (through variables having the relationship) :

$$\{P'\} = [A^t]\{P\} \quad (2-6)$$

where

$\{P'\}$ = the applied joint loads in global coordinates,
 $[(2n-1) \times 1]$

$\{P\}$ = member forces in global coordinates due to
 applied joint loads, $(2b \times 1)$

The summation of all member forces may be defined as :

$$\{R\} = \{P\} + \{p\} \quad (2-7)$$

where

$\{R\}$ = the total member forces in global coordinates,
 $(2b \times 1)$

$\{p\}$ = the member induced forces in global coordinates
 (e.g., thermal, member misfit), $(2b \times 1)$

The total member forces for member 3 in Figure (6d) can be shown by Equation (2-7) to be :

$$\{-R_{x4}, -R_{y4}, R_{x6}, R_{y6}\}^T = \{-P_x, -P_y, P_x, P_y\}^T + \{-P_{x4}, P_{y4}, P_{x6}, P_{y6}\}^T \quad (2-8)$$

But the sum of the member induced forces at every joint is zero (See Appendix B). Hence

$$[A^t]\{p\} = 0 \quad (2-9)$$

Premultiplying Equation (2-7) by $[A^t]$, yields :

$$[A^t]\{R\} = [A^t]\{P\} + [A^t]\{p\} \quad (2-10)$$

Substituting Equations (2-6) and (2-9) into Equation (2-10), one obtains :

$$\{P\} = [A^t]\{R\} \quad (2-11)$$

The physical properties of the elements constituting the branches are expressed by :

$$\{R\} = [K]\{V\} \quad (2-12)$$

where

$[K]$ = A diagonal matrix in global coordinates which

represents the physical properties of the branches and is referred to as the unstructured member stiffness matrix, (bxb). An example of matrix [K] is shown in Figure (3b). Let the global unstructured member stiffness matrices of member 1, 2, and 3 be k_{12} , k_{13} , and k_{23} , respectively. Hence :

$$[K] = \begin{bmatrix} k_{12} & 0 & 0 \\ 0 & k_{13} & 0 \\ 0 & 0 & k_{23} \end{bmatrix}$$

Premultiplying Equation (2-12) by $[A^t]$, yields :

$$[A^t]\{R\} = [A^t][K]\{V\} \quad (2-13)$$

Substituting Equations (2-5) and (2-11) into Equation (2-13), one obtains :

$$\{P'\} = [A^t][K][A]\{u'\} \quad (2-14a)$$

$$\text{or } \{u'\} = [S]^{-1}\{P'\} \quad (2-14b)$$

where

$$[S] = [A^t][K][A]$$

Therefore, the total branch vector quantities $\{V\}$ and $\{R\}$ can be solved simultaneously in terms of the

applied joint loads in global coordinates as :

$$\{V\} = [A][S]^{-1} \{P\} \quad (2-15a)$$

$$\{R\} = [K][A][S]^{-1} \{P\} \quad (2-15b)$$

To represent the characteristics of a structural problem, a network model is developed to represent the structural system as shown in Table 2. The difference between a network model and a structural model is that the network variables are scalar quantities and the structural variables are vector quantities.

Table 2

Simulation Of Network Model To Structural Model

Network Model	Structural Model
a) An "across" variable obeys the mesh law : Σ Mesh distortions in a loop=0	a) A joint displacement obeys the compatibility relationships : Σ Displacements in a loop=0
b) A "through" variable obeys Kirchoff's node law : Σ Currents at any joint = 0	b) A force obeys the equilibrium conditions : Σ Forces at the joints = 0
c) The physical properties of the elements constituting the branch are : $\{R\} = [K]\{V\}$	c) Hooke's law of materials are : $\{F\} = [K]\{\Delta\}$

A fundamental theory of network graph theory as applied to structural engineering uses the 3 principle conditions of analysis: equilibrium, compatibility, and Hooke's law of materials.

(a) Equilibrium Conditions; the summation of forces at each nodes must be in equilibrium. The sign convention of these forces are :

- positive value is a force going into a node
- negative value is a force going out a node

(b) Compatibility relationships; the summation of displacements in a loop defined in a network graph must be equal to zero. The sign convention of displacements depends upon the direction of a loop and a member direction within the loop. A loop direction is assigned either clockwise or counter-clockwise, e.g., from Figure (7a) a clockwise direction is AECA. If both a loop and a member direction are the same, the sign of the displacement is "Positive". If not, it is represented by "Negative".

(c) Hooke's law of material; forces are associated with displacements due to the properties of the material in each members in a linear manner.

Figure (7a) depicts a statically indeterminate truss as a pinned connected structure. The hinge supports are located at A and B. The applied joint load quantities, $P_1 - P_8$, and displacement quantities, $X_1 - X_8$, are specified at joints C,D,E and F in global coordinates

as shown in Figure (7a).

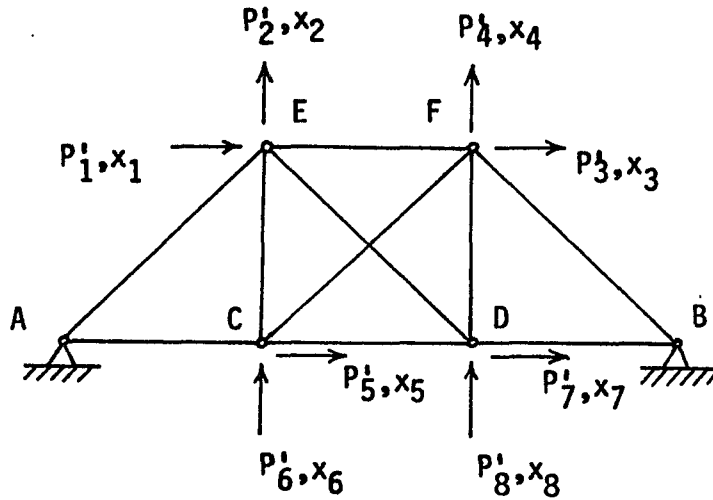

(7a) Forces And Displacements At The Joints In Global Coordinates

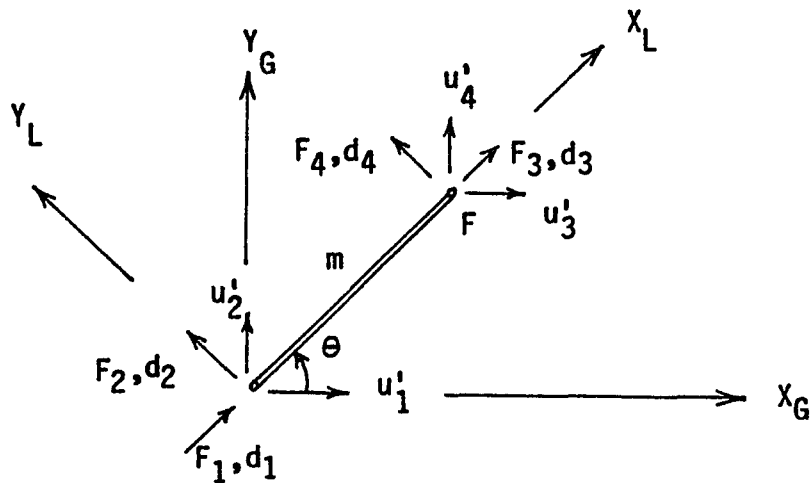

FIG. (7b) Forces And Displacements For Member m In Local Coordinates

The forces and displacements for member m are shown in Figure (7b) where m is an arbitrary number (1,2,3....) designating a member of a structure. A stiffness matrix for member m is written in local coordinates as :

$$[K]_m = \begin{bmatrix} EA/L & 0 & -EA/L & 0 \\ 0 & 0 & 0 & 0 \\ -EA/L & 0 & EA/L & 0 \\ 0 & 0 & 0 & 0 \end{bmatrix} \quad (2-16)$$

where

$[K]_m$ = the member stiffness matrix for member m in local coordinates

E = modulus of elasticity

A = member cross-sectional area

L = length of member

The member distortions in global coordinates are designated by $\{V\}$. Generally, the member distortions for pinned connected structures are :

$$\{V\} = \{U\} + \{u\} = \{U\} + [A]\{u'\} \quad (2-17a)$$

where

- $\{V\}$ = total member distortions in global coordinates ($6 \times Nm$)
 $\{U\}$ = applied member distortions (due to discontinuity) ($3 \times Nm$)
 $\{u\}$ = member distortions due to applied loads in global coordinates
 $\{u'\}$ = joint displacements in global coordinates ($3 \times Nj$)
 $[A]$ = branch-node incidence matrix, a value in this matrix is associated with all values in global coordinates

The discontinuity member distortions $\{U\}$ are assumed to be zero for the pinned connected structures investigated, Thus

$$\{V\} = \{u\} = [A]\{u'\} \quad (2-17b)$$

Using Equation (2-12), the load-deflection relationship, the axial member forces are :

$$\{R\} = [K]\{V\} = [K][A]\{u'\} \quad (2-18)$$

where

- $\{R\}$ = the axial member forces in global coordinates
 $[K]$ = unstructured members stiffness matrix in global coordinates

[A] = a branch-node incidence matrix associated with the geometry transformation for the entire structure

[u`] = joint displacements for the entire structure in global coordinates, i.e., X_1 to X_8

Under joint equilibrium conditions, the summation of the total member forces at a node is equal to the applied joint loads at that node. Therefore, for the complete system :

$$\{P'\} = [A^t]\{R\} \quad (2-19)$$

where

{P'} = applied joint loads in global coordinates, i.e., P_1' to P_8'

Substituting Equation (2-18) into Equation (2-19), one obtains :

$$\{P'\} = [A^t][K][A]\{u'\} \quad (2-20a)$$

$$\text{or } \{P'\} = [S]\{u'\} \quad (2-20b)$$

where

[S] = $[A^t][K][A]$ = structured global stiffness matrix

Solving for the joint displacements, Equation (2-20) becomes :

$$\{u'\} = [S]^{-1} \{P'\} \quad (2-21)$$

Substituting Equation (2-21) into Equation (2-17b) and Equation (2-18) respectively, yields :

$$\{V\} = [S]^{-1} \{P'\} \quad (2-22a)$$

$$\{R\} = [K][A][S]^{-1} \{P'\} \quad (2-22b)$$

From Equations (2-21), (2-22a) and (2-22b), if the joint loads and member properties of the structure are known, the joint displacements, the member distortions, and the axial member forces in global coordinates can be determined. The member distortions $\{V\}$ and the axial member forces $\{R\}$ can be converted to $\{V^*\}$ and $\{R^*\}$ in local coordinates by premultiplying by the coordinate transformation matrix $[\tilde{T}]$, e.g., $\{R^*\} = [\tilde{T}]\{R\}$ where $\{R^*\} = \{F_1, F_2, F_3, F_4\}$ for member m in Figure (7b).

The analysis and design of statically indeterminate structures to meet specified requirements (i.e., joint displacements, member forces or member stresses) is handled by analyzing the system in an iterative method. The structural member properties (i.e., member area) are assumed in order to produce the member

stiffness matrix, which is used in Equation (2-21) and Equation (2-22), to satisfy the specified requirements. A trial-and-error procedure is then performed until a feasible solution is reached.

An analysis by the Singular Imbedding Method is developed to eliminate this time consuming process. This procedure modifies the network graph by introducing two new systems into the analysis. A Displacement Constraining System (DC) is introduced to constrain joint displacements and a Force Constraining System (FC) is established to constrain forces or stresses in the members. Using these systems member properties can be designated as variable. The role of these systems in the structural stiffness analysis is explained in the next section.

2.2 Singular Systems

The DC (Displacement Constraining) and FC (Force Constraining) systems are associated with the network graph to constrain a structure. To graphically represent the force and displacement constraints such that only the proper equations in the analysis are adjusted, ideal members and ideal loads are used in the constraining system. These systems when added to the network graph enter a value of zero on the main diagonal of the structural stiffness matrix which causes the matrix to be

singular (the zero value represents a member with zero stiffness). Thus the systems are referred to as singular systems.

The schematic of the DC is shown in Figure 8. Nodes i, j and k represent a structural network graph which are connected to branches a, b and c , respectively. To constrain the displacement at joint k with a specified value relative to joint i , the DC system is applied parallel to member c and is connected between nodes i and k as shown in Figure (8a). Node i may be a fixed or free node depending upon the characteristics of the structure, e.g., a support condition is equivalent to a fixed or datum node, while joints in the structure are equivalent to free nodes.

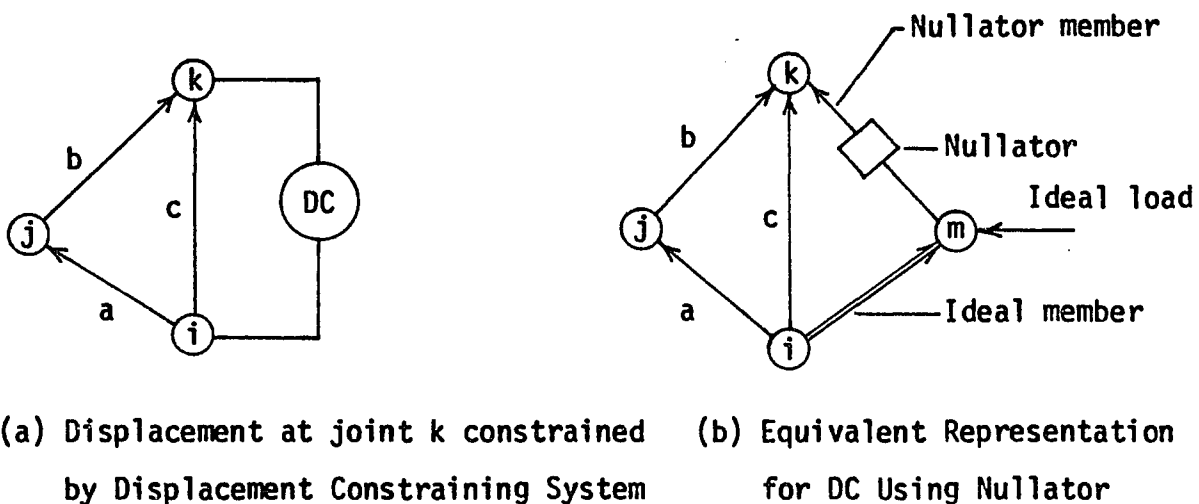

FIG. 8 DC SYSTEM

From a conceptual point of a view, the DC element

can be represented by the following structural components. It consists of a nullator, an ideal member, and an ideal joint load. These components are connected as shown in Figure (8b) with the following physical meanings ;

1) a nullator is defined as a member which is used to indicate the displacement constraint relationship between nodes k and m in Figure (8b). The stiffness of the nullator member is equivalent to zero. Therefore, the force and displacement must be zero between node k and m . The displacement constraining values at node k are forced to be equal to those at node m ($u_k = u_m$). The nullator is connected to the joint whose displacement is constrained.

2) an ideal member must be connected in series with a nullator. This member is used to hold the displacement at node m which is related to node i by equilibrium and continuity laws.

3) an ideal joint load represents the applied load at node m as a function of the displacement constraining value ($\{F_k\} = [K]\{u_k\}$).

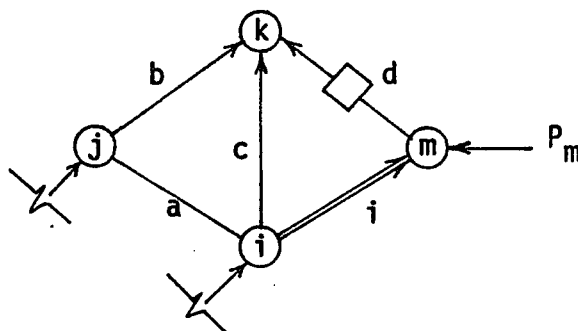

FIG. 9 DC System And A Part Of Network Graph

For example, a part of a network graph is shown in Figure 9. with a DC system (members d and i) included. The unstructured structural stiffness matrix for this network graph is :

$$[K] = \begin{bmatrix} [K_a] & 0 & 0 & 0 & 0 \\ 0 & [K_b] & 0 & 0 & 0 \\ 0 & 0 & [K_c] & 0 & 0 \\ 0 & 0 & 0 & [K_i] & 0 \\ 0 & 0 & 0 & 0 & [0] \end{bmatrix} \quad (2-23)$$

where

$[K_a], [K_b], [K_c]$ = the global stiffness matrices for members a, b, c (one of these members can be treated as variable)

$[K_i]$ = a global stiffness matrix for the ideal member

$[K_d]$ = a global stiffness matrix for the nullator = $[0]$

The matrix in Equation (2-23) is singular due to the 5th row and column being all zeros.

Similarly, the schematic of an FC is shown in Figure 10. To constrain a force in member c with a specified value, the FC system is applied in series with member c toward node k, which is the negative end of the

member. The positive or negative end of a member is expressed in terms of the member incidence as discussed in chapter 1.

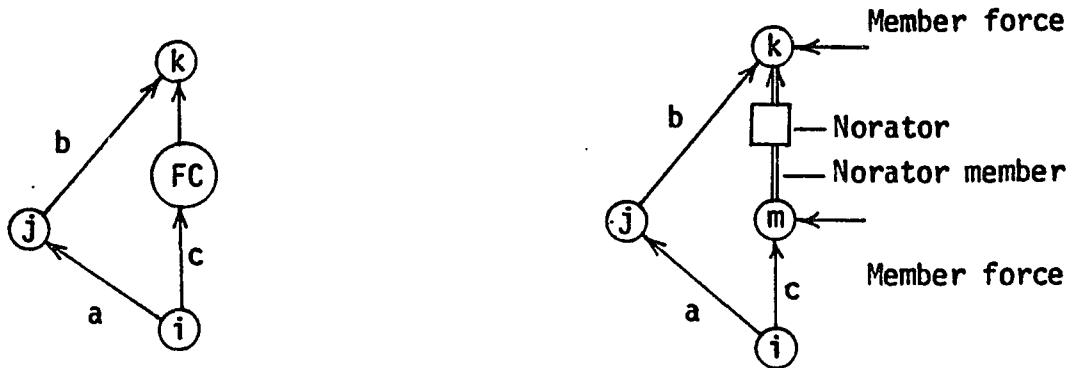

(a) Member force in member *c*
Constrained by Force
Constraining System

(b) Equivalent Representation
for FC Using Norator

FIG. 10 FC SYSTEM

From Figure (10b), the FC system consists of a norator and member force. A norator is connected in series between the node *k* and the new node *m*, which must be introduced between the negative end and the variable member *c*. The property of a norator allows a displacement and a force to occur in a member with a zero stiffness relationship specified. Member *c* is the variable member in the FC system. The magnitude of the force constraint is represented by the member force. Joint equilibrium at joint *m* makes the force induced in member *c* equal to the force constraint.

DC and FC systems were represented by the

structural components as described. The characteristics of these two structural systems must obey the node and mesh laws of network analysis. Let us consider a part of a network graph which is connected to a DC and/or an FC system.

A part of a network graph is added to a DC system as shown in Figure 11. for illustration purposes.

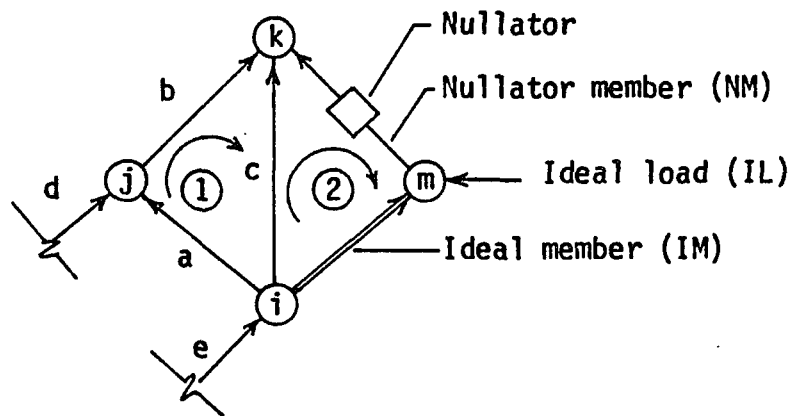

FIG. 11 Network Graph With DC System

A nullator specifies that the force and displacement must be zero between nodes k and m. For a plane truss problem the network equations for Figure 10. are :

(a) Equilibrium conditions :

$$\begin{array}{rcl}
 \text{at node } \textcircled{k} & H_b + H_c & = 0 \\
 & V_b + V_c & = 0 \\
 \text{at node } \textcircled{j} & H_a - H_b + H_d & = 0 \\
 & V_a - V_b + V_d & = 0 \\
 \text{at node } \textcircled{i} & H_a + H_c + H_{IM} - H_e & = 0 \\
 & V_a + V_c + V_{IM} - V_e & = 0 \\
 \text{at node } \textcircled{m} & H_{IM} - H_{IL} & = 0 \\
 & V_{IM} - V_{IL} & = 0
 \end{array}
 \left. \vphantom{\begin{array}{rcl}
 \text{at node } \textcircled{k} \\
 \text{at node } \textcircled{j} \\
 \text{at node } \textcircled{i} \\
 \text{at node } \textcircled{m}
 \end{array}} \right\} (2-24)$$

(b) Compatibility relationships :

$$\begin{array}{rcl}
 \text{Loop } \textcircled{1} & \Delta x_c - \Delta x_{IM} - \Delta x_{NM} & = 0 \\
 \text{or} & \Delta x_c - \Delta x_{IM} & = 0 \\
 \text{where} & \Delta x_{NM} & = 0 \\
 & \Delta y_c - \Delta y_{IM} - \Delta y_{NM} & = 0 \\
 \text{or} & \Delta y_c - \Delta y_{IM} & = 0 \\
 \text{where} & \Delta y_{NM} & = 0 \\
 \\
 \text{Loop } \textcircled{2} & \Delta x_a + \Delta x_b - \Delta x_c & = 0 \\
 & \Delta y_a + \Delta y_b - \Delta y_c & = 0
 \end{array}
 \left. \vphantom{\begin{array}{rcl}
 \text{Loop } \textcircled{1} \\
 \text{where} \\
 \text{or} \\
 \text{where} \\
 \\
 \text{Loop } \textcircled{2}
 \end{array}} \right\} (2-25)$$

(c) Hooke's law :

$$\left. \begin{aligned}
 F_a &= K_a \Delta_a \\
 F_b &= K_b \Delta_b \\
 F_c &= K_c \Delta_c \\
 F_{IM} &= K_{IM} \Delta_{IM}
 \end{aligned} \right\} \quad (2-26)$$

From Equation (2-24) through Equation (2-26), it is clear that the nullator and nullators do not affect these equations. The ideal member affects all 3 equations due to its member stiffness. But the ideal load affects only the equilibrium conditions as a function of the displacement constraint.

A part of the network graph is added to a FC system as shown in Figure 12.

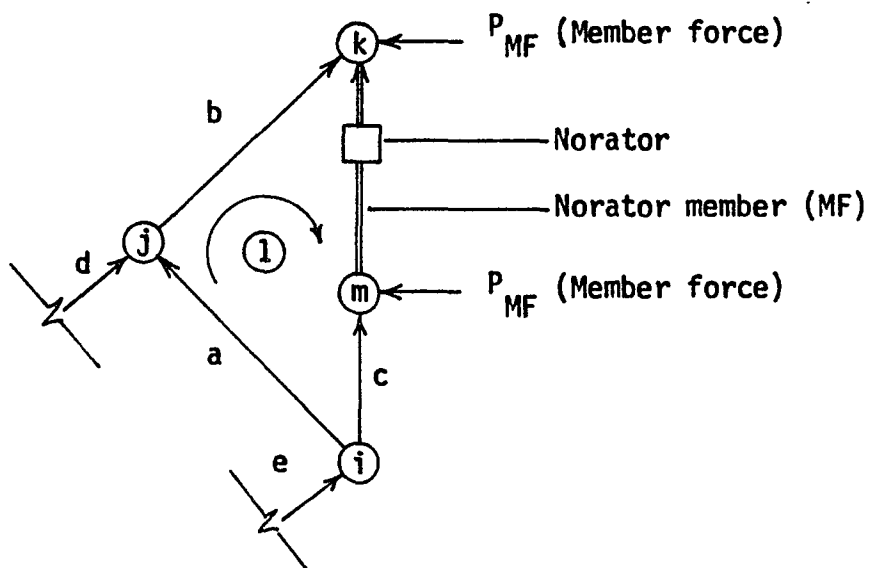

FIG. 12 Network Graph With FC System

The definition of a norator in terms of force and displacement will be defined as :

$$\text{Norator (F,u) = Norator (a,b)}$$

where F and u are represented by a, b as member force and member distortion, respectively. The values of a and b are arbitrary values which vary from 0 to infinity. In this thesis, a member distortion for a norator is defined as having a value zero. For a two dimensional network analysis the :

(a) Equilibrium conditions are :

$$\begin{array}{l}
 \text{at node } \textcircled{i} \quad H_a + H_c - H_e = 0 \\
 \quad \quad \quad V_a + V_c - V_e = 0 \\
 \text{at node } \textcircled{j} \quad H_a + H_d - H_b = 0 \\
 \quad \quad \quad V_a + V_d - V_b = 0 \\
 \text{at node } \textcircled{m} \quad \quad \quad H_c - H_{MF} = 0 \\
 \quad \quad \quad \quad \quad V_c - V_{MF} = 0 \\
 \text{at node } \textcircled{k} \quad \quad \quad H_b + H_{MF} = 0 \\
 \quad \quad \quad \quad \quad V_b + V_{MF} = 0
 \end{array} \quad \left. \vphantom{\begin{array}{l} \\ \\ \\ \\ \\ \\ \\ \end{array}} \right\} (2-27)$$

(b) Compatibility relationships are :

$$\begin{array}{rcl}
 \text{Loop } \textcircled{1} & \left. \begin{array}{l} \Delta x_a + \Delta x_b - \Delta x_{MF} - \Delta x_c = 0 \\ \Delta x_{MF} = 0 \\ \Delta y_a + \Delta y_b - \Delta y_{MF} - \Delta y_c = 0 \\ \Delta y_{MF} = 0 \end{array} \right\} & (2-28)
 \end{array}$$

(c) Hooke's law is :

$$\begin{array}{rcl}
 F_a & = & K_a \Delta_a \\
 F_b & = & K_b \Delta_b \\
 F_c & = & K_c \Delta_c \\
 F_{MF} & = & K_{MF} \Delta_{MF}
 \end{array} \left. \vphantom{\begin{array}{rcl} F_a \\ F_b \\ F_c \\ F_{MF} \end{array}} \right\} (2-29)$$

From Equation (2-27) through Equation (2-29), it is clear that the norator affects these equations due to a member force applied to the norator member which represents the force constraint.

2.3 Singular Structural Imbedding

In the Singular Imbedding Analysis, there are two different kinds of members in the problem, one is a defined member, the other is an undefined member or variable member. A defined member is a structural member whose characteristic properties of area, modulus of elasticity, and length are known or defined. A variable member is a member with an unknown cross-sectional area.

The symbol for a variable member is a dashed line in a graph.

Recalling Figure (8b), member c is selected as a variable member, as shown in Figure (13b). The structural stiffness matrix is then developed with a DC system included.

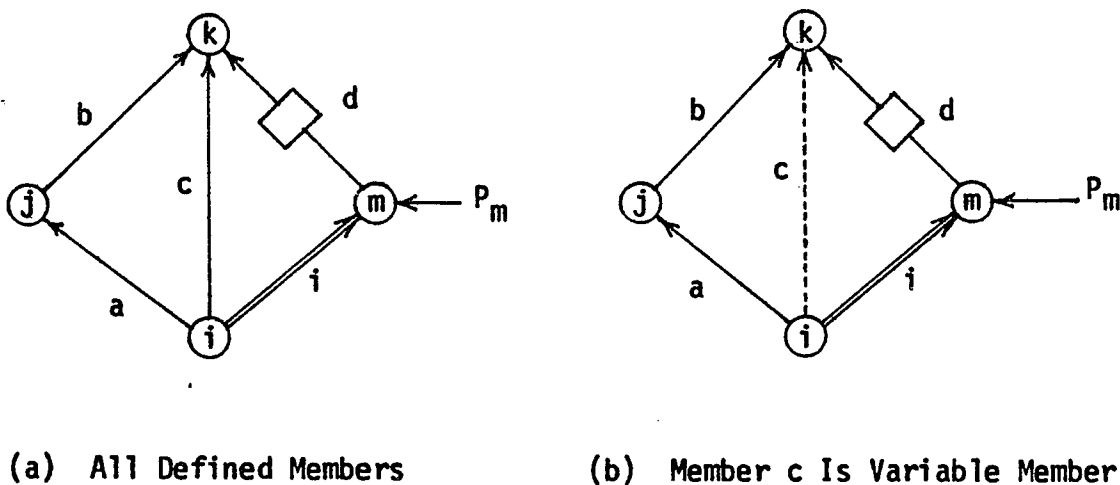

FIG. 13 Structural Stiffness Matrix For Adding DC

The displacement at node k is constrained relative to node i. The direction of the members a, b, c, i, and d are i-j, j-k, i-k, i-m, and m-k, respectively. The global member stiffness matrices for members a, b and c are $[K_a]$, $[K_b]$ and $[K_c]$

The ideal member stiffness matrix has arbitrary values which are defined relative to the constrained

displacement values. The formulation of this relationship is :

$$\{P_m\}_{(nx1)} = [K_i]_{(nxn)} \{u_k\}_{(nx1)} \quad (2-30)$$

where

$\{P_m\}$ = an applied joint load at node m in global coordinates .

$[K_i]$ = a global stiffness matrix for the ideal member

$\{u_k\}$ = a joint displacement at node k in global coordinates

By definition, the stiffness of the nullator $[K_d]$ is equal to zero. The global unstructured stiffness matrix of the network graph after adding the DC system, becomes :

$$[K_m]^a = \begin{bmatrix} [K_a] & 0 & 0 & 0 & 0 \\ 0 & [K_b] & 0 & 0 & 0 \\ 0 & 0 & [K_c] & 0 & 0 \\ 0 & 0 & 0 & [K_i] & 0 \\ 0 & 0 & 0 & 0 & [0] \end{bmatrix} \quad (2-31)$$

$$[K_m]^b = \begin{bmatrix} [K_a] & 0 & 0 & 0 & 0 \\ 0 & [K_b] & 0 & 0 & 0 \\ 0 & 0 & 0 & 0 & 0 \\ 0 & 0 & 0 & [K_f] & 0 \\ 0 & 0 & 0 & 0 & [0] \end{bmatrix} \quad (2-32)$$

where

$[K_m]^a$ = an unstructured global stiffness matrix
with member c defined

$[K_m]^b$ = an unstructured global stiffness matrix
with zero stiffness for variable member c

$[0]$ = a nullator global stiffness matrix, (1x1)

Similarly, the structural stiffness matrix is developed for an FC system (Figure 14.). The norator allows a displacement and force to occur between nodes k and m. A norator element with zero stiffness is used to constrain a member force. The displacement between nodes k and m is not affected by the norator. In other words, a joint displacement at k equals the joint displacements at m. Therefore, the global member stiffness matrix of a norator is zero in the analysis.

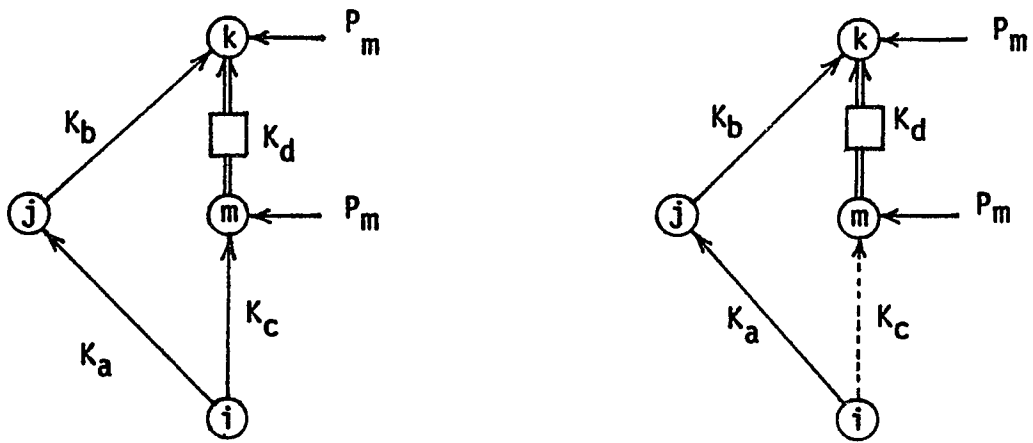

(a) All Defined Members

(b) Member c Is Variable Member

FIG. 14 Structural Stiffness Matrix For Adding FC

The unstructured global stiffness matrix including a nodator element is :

$$[K_n]^a = \begin{bmatrix} [K_a] & 0 & 0 & 0 \\ 0 & [K_b] & 0 & 0 \\ 0 & 0 & [K_c] & 0 \\ 0 & 0 & 0 & [0] \end{bmatrix} \quad (2-33a)$$

$$[K_n]^b = \begin{bmatrix} [K_a] & 0 & 0 & 0 \\ 0 & [K_b] & 0 & 0 \\ 0 & 0 & 0 & 0 \\ 0 & 0 & 0 & [0] \end{bmatrix} \quad (2-33b)$$

where

- $[K_n]^a$ = an unstructured global stiffness matrix
with defined member c
- $[K_n]^b$ = an unstructured global stiffness matrix
using zero stiffness for the variable
member c
- [0] = a noraor global stiffness matrix, (1x1)

From a conceptual point of a view, the FC system is represented as the elements and ideal loads between nodes i-k (Figure 14.). This system transfers the same magnitude as the member constrained force. The applied ideal loads at nodes k and m are equal to the constrained forces. Hence

$$\{P_k\} = \{P_m\} = \text{constrained forces} \quad (2-34)$$

In two dimensional analysis, the displacement constraint will occur in the x and y directions, which defines the maximum value of the DC member for one free node. The structural stiffness matrix of the problems can be described in terms of the unstructured form. Therefore, adding DC and FC systems into the network graph, the unstructured stiffness matrices can be written in the general form as :

$$[K]_m = \begin{bmatrix} [K]_{1,1} & 0 & 0 \\ 0 & [K]_{2,2} & 0 \\ 0 & 0 & [K]_{3,3} \end{bmatrix} \quad (2-35a)$$

$$[K]_n = \begin{bmatrix} [K]_{1,1} & 0 & 0 \\ 0 & [K]_{2,2} & 0 \\ 0 & 0 & [K]_{3,3} \end{bmatrix} \quad (2-35b)$$

where

$[K]_m$ = a global stiffness matrix for a problem with DC's

$[K]_n$ = a global stiffness matrix for a problem with FC's

$[K]_{1,1}$ = stiffness submatrix for the defined members

$[K]_{2,2}$ = stiffness submatrix for the variable members

$[K]_{3,3}$ = stiffness submatrix for the ideal members and nullators or norators

Singular Imbedding Analysis can be developed and tested for structural problems, e.g., planar trusses, planar frames etc. Examples of planar truss problems are shown in Figure 15. The statically indeterminate trusses are given as :

(a) A constrained displacement Δx with one variable member.

(b) Two constrained displacements Δx and Δy with two variable members.

(c) A constrained force Q with one variable member.

A network graph including DC and FC systems are shown in Figures (15a, 15b, 15c)

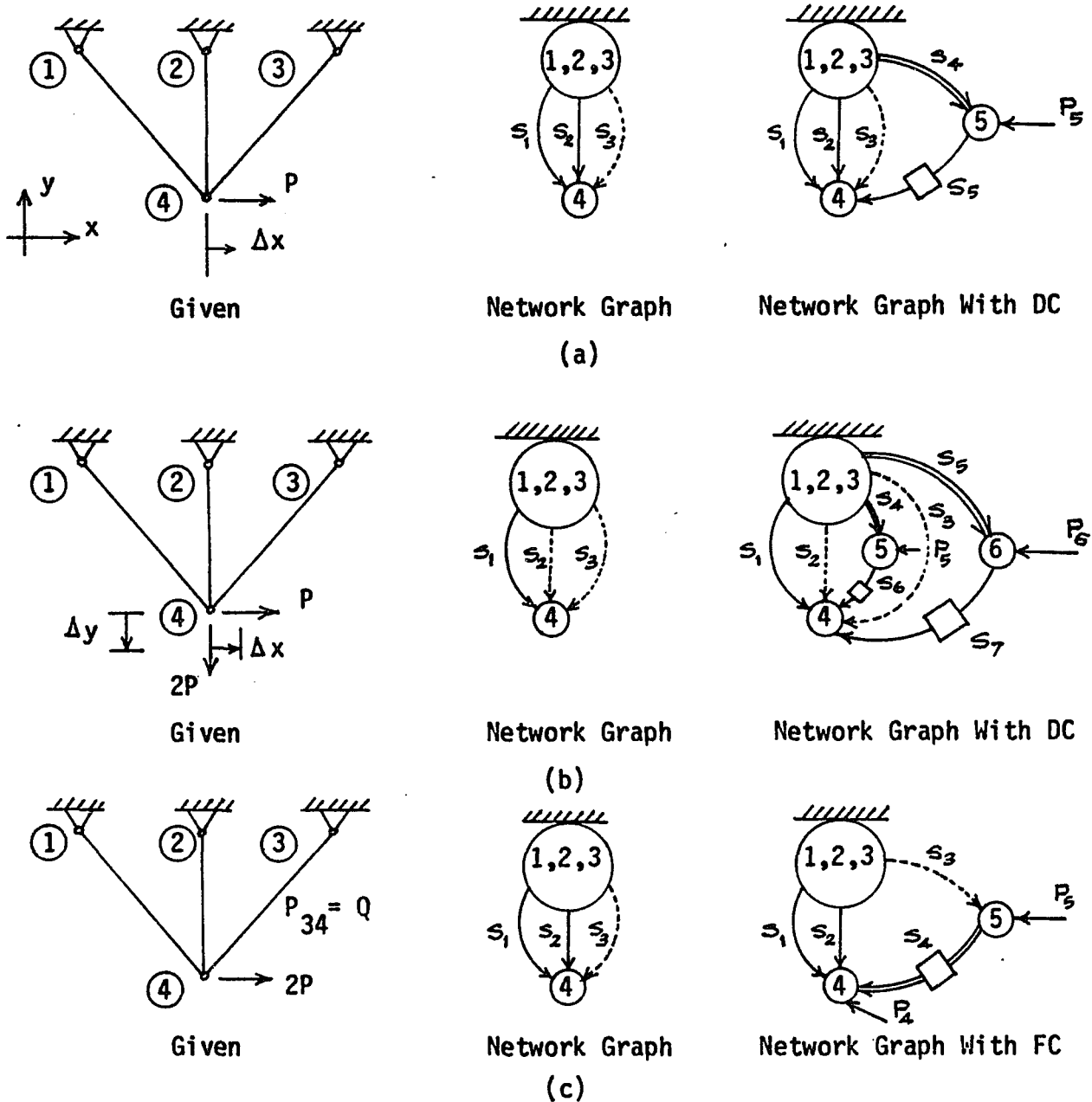

FIG. 15 Examples Of Planar Truss Problems

2.4 Nodal Equations For DC and FC systems

In the last section, examples of the structural problems were demonstrated using a DC (Displacement Constraining) system and an FC (Force Constraining) system. Due to their physical properties, these systems will affect the unstructured stiffness matrix. After the DC and/or FC systems have been incorporated, Equation (2-20) is used to obtain the structured stiffness matrix [S]. To correct the singularity of the structured stiffness matrix, two techniques are used.

Substituting the value of [S] for the general problem into Equation (2-20), one obtains :

$$\begin{bmatrix}
 S_{11} & S_{12} & \dots & S_{1i} & \dots & S_{1j} & \dots & S_{1n} \\
 S_{21} & S_{22} & \dots & S_{2i} & \dots & S_{2j} & \dots & S_{2n} \\
 \cdot & \cdot & & & & & & \cdot \\
 S_{p1} & S_{p2} & \dots & \dots & \dots & \dots & \dots & S_{pn} \\
 \cdot & \cdot & & & & & & \cdot \\
 S_{q1} & S_{q2} & \dots & \dots & \dots & \dots & \dots & S_{qn} \\
 \cdot & \cdot & & & & & & \cdot \\
 S_{m1} & S_{m2} & \dots & S_{mi} & \dots & S_{mj} & \dots & S_{mn}
 \end{bmatrix}
 \begin{Bmatrix}
 u_1 \\
 u_2 \\
 \cdot \\
 u_i \\
 \cdot \\
 u_j \\
 \cdot \\
 u_n
 \end{Bmatrix}
 =
 \begin{Bmatrix}
 P_1 \\
 P_2 \\
 \cdot \\
 P_p \\
 \cdot \\
 P_q \\
 \cdot \\
 P_m
 \end{Bmatrix}
 \quad (2-36)$$

where

{u`} is a vector of joint displacements in global coordinates

{P`} is a vector of applied joint loads in global

coordinates

Suppose that the nullator is connected between nodes i and j . Since the nullator allows no displacements to occur in a particular global direction, u_i and u_j in that direction are constrained to be equal. The displacements for nodes i and j in that constrained direction can be written as $u_i = u_j = u_{ij}$. Since there is no relative displacement between joint i and joint j in the constrained direction, they can be treated as a single joint. To accomplish this the single joint must have the same stiffness as the combined stiffness of joints i and j . This is done by adding columns i and j in the structural stiffness matrix as follows :

$$\begin{bmatrix}
 S_{11} & S_{12} & \dots & (S_{1i} + S_{1j}) & \dots & S_{1n} \\
 S_{21} & S_{22} & \dots & (S_{2i} + S_{2j}) & \dots & S_{2n} \\
 \cdot & \cdot & & & & \cdot \\
 \cdot & \cdot & & & & \cdot \\
 \cdot & \cdot & & & & \cdot \\
 \cdot & \cdot & & & & \cdot \\
 \cdot & \cdot & & & & \cdot \\
 S_{m1} & S_{m2} & \dots & (S_{mi} + S_{mj}) & \dots & S_{mn}
 \end{bmatrix}
 \begin{Bmatrix}
 u_1 \\
 u_2 \\
 \cdot \\
 \cdot \\
 u_{ij} \\
 \cdot \\
 \cdot \\
 u_n
 \end{Bmatrix}
 =
 \begin{Bmatrix}
 P_1 \\
 P_2 \\
 \cdot \\
 P_p \\
 \cdot \\
 P_q \\
 \cdot \\
 P_m
 \end{Bmatrix}
 \quad (2-37)$$

The FC system is added into the problem to constrain member forces. From the network graph, the nullator allows forces to transfer as constrained values.

The nodal equations will be affected due to the equilibrium of forces in the global x and y directions for 2 dimensional problems. The nodal forces at p will be transferred to node q, and the summation of the forces in the global x and y coordinates remains in equilibrium. To accomplish this the rows of Equation (2-36), representing the equilibrium equations are added as follows :

$$\begin{bmatrix} S_{11} & S_{12} & \dots & S_{1n} \\ S_{21} & S_{22} & \dots & S_{2n} \\ \cdot & \cdot & & \cdot \\ (S_{p1} + S_{q1}) & (S_{p2} + S_{q2}) & \dots & (S_{pn} + S_{qn}) \\ \cdot & \cdot & & \cdot \\ S_{m1} & S_{m2} & & S_{mn} \end{bmatrix} \begin{Bmatrix} u_1 \\ u_2 \\ \cdot \\ \cdot \\ \cdot \\ u_n \end{Bmatrix} = \begin{Bmatrix} P_1 \\ P_2 \\ \cdot \\ (P_p + P_q) \\ \cdot \\ P_m \end{Bmatrix}$$

(2-38)

2.5 Variable Members In Problems

In a structural stiffness analysis, nodal equations are used to solve the problem. But in the Singular Imbedding Analysis, the nodal equations are divided into two parts. The first part includes the equations of the defined members and the DC or FC systems. The second part involves applied joint loads which are specified on the variable (undefined) members. The summation of these two parts is called the final nodal equations for the Singular Imbedding Analysis. Hence

$$[S]\{u'\} + [A_g^t]\{P_g\} = \{P'\} \quad (2-39)$$

where

$[S]$ = the structured stiffness matrix

$\{u'\}$ = joint displacements

$[A_g]$ = the branch-node incidence matrix associated with a geometry transformation of the variable members

$\{P_g\}$ = the member forces due to specified applied joint loads for the variable members in global coordinates

$\{P'\}$ = applied joint loads

Partitioning the matrices, Equation (2-39) becomes :

$$[[A_g^t] \mid [S]] \begin{Bmatrix} P_g \\ u' \end{Bmatrix} = \{P'\} \quad (2-40)$$

Equation (2-40) is a final nodal equation for the general problem. The application of Equation (2-40) depends upon the problem, e.g., planar trusses, planar frames. $[S]$ and $[A_g^t]$ are the parametric matrices which define the type of problem. Similarly, $\{P_g\}$ and $\{u'\}$ are the parametric vectors which control the types of constraints, e.g., displacement constraints, force constraints. The types of constraints will be discussed in the next section.

CHAPTER 3

EQUALITY CONSTRAINTS

3.1 Types Of Constraints

Applying the Singular Imbedding Method to a structural problem, enables a variable to be used to design the member properties, (i.e., cross-sectional area). To define the structure, a displacement or a member force is constrained and the variable member property is determined. If a displacement or a member force is equal to a desired value, it is referred to as an "Equality Constraint". If it is restricted in a range of values, it is referred to as an "Inequality Constraint".

In this chapter, planar trusses will be discussed with equality constraints. A member force constraint (or a member stress constraint) constrains the force in a selected member. A displacement constraint refers to joint displacements. Similarly, that joint of the structure can be a joint of a defined member or a joint of a variable member. Therefore, the behavior constraints such as member forces, stresses, and displacements or design constraints such as cross-sectional area can be imposed for defined members or variable members. The

types of equality constraint problems investigated are :

- (i) a joint displacement constraint
- (ii) a member force constraint
- (iii) a member stress constraint

These problems will be solved by using the final structural stiffness matrix equation. This equation depends upon the types of structural elements, (i.e., a Displacement Constraining system or a Force Constraining system) that are added into the network graph. Let us consider a truss with an applied load P as shown in Figure (16a). Member 3 is selected as a variable member. The network graph that represents this problem is shown in Figure (16b).

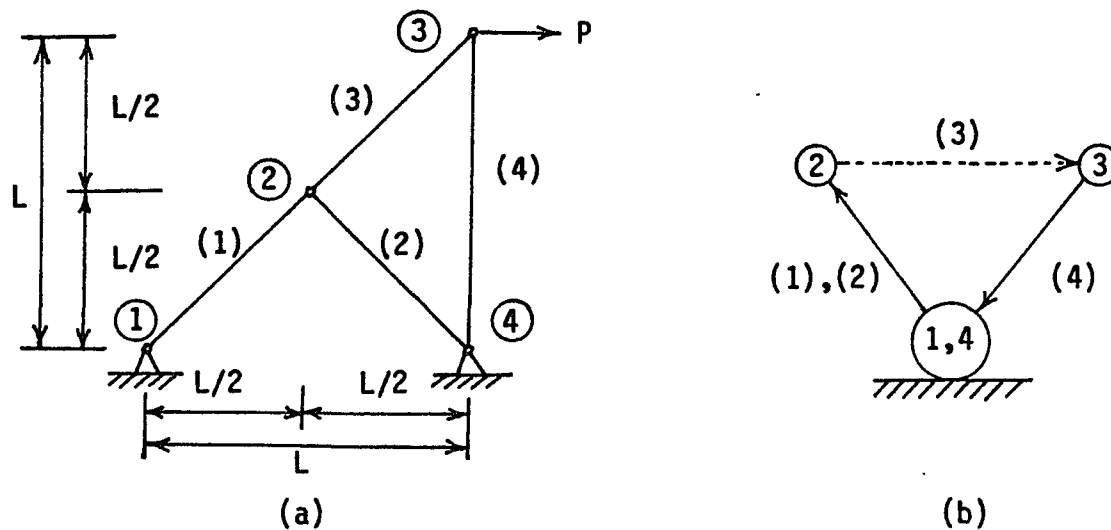

FIG. 16 Truss And Equivalent Of Network Graph

According to Equation (2-40), a final nodal equation for this problem is written in the form of

submatrices as :

$$[[A_3^t]; [S]_{124}] \begin{Bmatrix} P_3 \\ \hline u_{23} \end{Bmatrix} = \{P_{23}\} \quad (3-1)$$

where

- $[A_3]$ = the branch-node incidence matrix associated with a geometry transformation of member 3
- $[S]_{124}$ = the global stiffness matrix for members 1, 2, and 4
- $\{P_3\}$ = the member force of member 3 in global coordinates
- $\{u_{23}\}$ = joint displacements at nodes 2 and 3 in global coordinates
- $\{P_{23}\}$ = applied joint loads at nodes 2 and 3 in global coordinates

Adding either a DC or an FC system into the network graph, Equation (3-1) will be affected and becomes a new equation which is called the final structural stiffness matrix equation. From the problem above, two cases of constraints are explained as :

Joint Displacement Constraint :

The displacement at joint 3 relative to joint 4 is constrained by an amount Δx . Therefore, a DC system is needed in the network graph as shown in Figure 17.

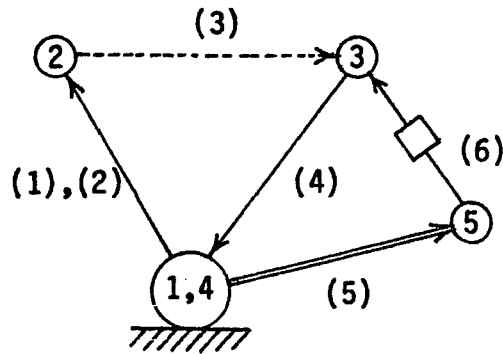

FIG. 17 Adding DC To Constrain Displacement Δx

By adding a DC system into the network graph, the final structural stiffness matrix equation becomes :

$$\begin{bmatrix} [A_3^t] \\ [0] \end{bmatrix} \begin{bmatrix} [S] \end{bmatrix} \begin{Bmatrix} P_3 \\ u_{235} \end{Bmatrix} = \{ P_{235} \} \quad (3-2)$$

where

$[S]$ = the global stiffness matrix for members 1, 2, 4, 5, and 6

$[0]$ = the null matrix is added into the equation due to the addition of $[S]_5$ and $[S]_6$ from $[S]_{124}$ in Equation (3-1)

$\{u_{235}\}$ = joint displacements at nodes 2, 3, and 5 in global coordinates

$\{P_{235}\}$ = applied joint loads at nodes 2, 3, and 5 in global coordinates

From Equation (3-2), it is clear that a DC system affects the final nodal equation [Equation (3-1)] due to the inclusion of an ideal member (member 5), a nullator (member 6), joint displacements (at node 5), and applied joint loads (at node 5). Therefore, the final structural stiffness matrix equation is constructed.

Member Force Constraint :

The force in member 3 is constrained by an amount Q . Therefore, an FC system is added into the network graph as shown in Figure 18.

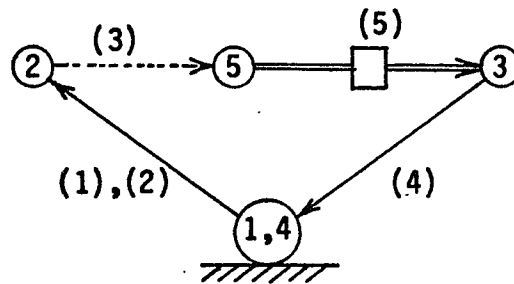

FIG. 18 Adding FC To Constrain Member Force Q

By adding an FC system into the network graph, the final structural stiffness matrix equation becomes :

$$\begin{bmatrix} [0] & [A_5^t] & \vdots & [S]_{1245} \\ [A_3^t] & [0] & \vdots & [0] \end{bmatrix} \begin{Bmatrix} P_3 \\ P_5 \\ \hline u_{235} \end{Bmatrix} = \begin{Bmatrix} P_{23} \\ P_5 \end{Bmatrix} \quad (3-3)$$

where

- $[A_5]$ = the branch-node incidence matrix
associated with the geometry transformation
for member 5
- $[S]_{1245}$ = the global stiffness matrix for members 1, 2,
4, and 5
- $[0]$ = the null matrix is added into the equation to
balance submatrices due to the magnification
of P_3 , P_5 , and u_{235}
- $\{P_5\}$ = the member force of member 5 in global
coordinates
- $\{P_5\}$ = applied joint loads at node 5 in global
coordinates

From Equation (3-3), it is clear that an FC system affects the final nodal equation [Equation (3-1)] due to the inclusion of a norator (member 5) and applied joint loads (at node 5). Similarly, the final structural stiffness matrix equation is constructed.

Next, the method for solving the final structural stiffness matrix equations [Equation (3-2) or Equation (3-3)] will be described, including examples of truss problems.

3.2 Displacement Constraints

For a two dimensional problem, a displacement

constraint for a free node can occur in either the x or y direction, or in both x and y directions. The method of Singular Imbedding approaches this by adding a DC (Displacement Constraining) system into the network graph for each constrained degree of freedom. The procedure for solving a displacement constrained problem will be described as follows :

(a) The structural problem is represented by a network graph. The support conditions are represented as a fixed or a datum node. A variable member is represented as a dashed line in the network graph. The solid lines that connect nodes represents defined members of the structure.

(b) A DC system is added between the constrained nodes. Note : The datum node can be used as one of the two constrained nodes. This enables a displacement constraint to be specified relative to the ground.

For a planar truss problem, the solutions are controlled as shown in Table 3.

Table 3

Displacement Constraints Controlling Condition

Condition	Controlling	Solutions
i	$v = c$	Solution is determined directly
ii	$v < c$	Solution is determined directly
iii	$v > c$	Solution is in feasible region
iv	unknowns > equations	Solution can not be determined

where v = number of variable members
 c = number of displacement constraints

These conditions will classify the type of problem and solution. The method of calculation is based upon the direct stiffness matrix method. The general procedure of the singular imbedding approach can be demonstrated as follows :

(a) Generate the nodal equations for the network graph which does not contain a variable member, but includes the value of the displacement or force constraint that is associated with the structure (as

described in chapter 2). Hence

$$[[A^t][K_m][A]]\{u'\} = \{W\} \quad (3-4)$$

where

[A] = a branch-node incidence matrix associated with the geometry transformation in global coordinates

[K_m] = a global stiffness matrix for the defined members and displacement constraint is defined in Equation (2-35a)

{u'} = joint displacements in global coordinates

{W} = a column matrix representing joint loads including constrained values in global coordinates

(b) Applied member forces are added into the nodal equations due to variable members. This member force is designated as {P_g} in local coordinates which is transformed to global coordinates by [A_g^t]. The matrix [A_g] is calculated by using a branch-node incidence matrix associated with the geometry transformation [T̃] (as given in appendix A). Therefore, a variable member is included in the analysis explicitly. Hence

$$[[A^t][K_m][A]]\{u'\} + [A_g^t]\{P_g\} = \{W\} \quad (3-5)$$

Partitioning matrices, Equation (3-5) becomes :

$$[[A_g^t] \parallel [A^t][K_m][A]]_{(n+c) \times (n+c+v)} \begin{Bmatrix} P_g \\ u' \end{Bmatrix}_{(n+c+v) \times 1} = \{W\}_{(n+c) \times 1} \quad (3-6)$$

Equation (3-6) is similar to Equation (3-2), but the null matrix has been inserted into matrix [A] instead of separated as in Equation (3-2).

(c) Equation (3-6) may be written as :

$$[[B_1] \parallel [B_2]]_{a \times b} \{M\}_{b \times 1} = \{W\}_{a \times 1} \quad (3-7)$$

where

$$[[B_1] \parallel [B_2]] = [[A_g^t] \parallel [A^t][K_m][A]]$$

$$\{M\} = \text{the unknown variable matrix } \begin{Bmatrix} P_g \\ u' \end{Bmatrix}$$

$$a = (n+c)$$

$$b = (n+c+v)$$

n = number of degrees of freedom

c = number of displacement constraints

v = number of variable members

Due to a DC element, the matrix [B₂] will be reduced by the number of displacement constraints. From Equation (2-37), the property of the nullators affects the nodal equation by adding columns to the stiffness matrix. Therefore, by adding the column of matrix [B₂] in Equation (3-7), one obtains :

$$[[B_1] \parallel [B_3]]_{ax(b-c)} \cdot \{M\}_{(b-c)x1} = \{W\}_{ax1} \quad (3-8)$$

where

$[B_3]$ = the product of $[A^t][K_m][A]$ after adding columns

(d) For conditions (i) and (ii), the number of variable members is equal to or less than the number of constrained values, the final structural stiffness matrix equation will be solved by direct inversion. Therefore, Equation (3-8) becomes :

$$[I] \begin{Bmatrix} M_1 \\ \dots \\ M_2 \end{Bmatrix} = \{\alpha\} \quad (3-9)$$

where

$[I]$ = a unit matrix, $[(n+c) \times (n+v)]$

$\{\alpha\} = ([B_1] \parallel [B_3])^{-1} \{W\}$

$\begin{Bmatrix} M_1 \\ \dots \\ M_2 \end{Bmatrix}$ = a vector of member forces in variable members in local coordinates and joint displacements in global coordinates

(e) For condition (iii), the number of variable members is greater than the number of constrained values. The method which will be used for modifying Equation (3-8) is the Gauss-Jordan method . After

applying this method to Equation (3-8), the result will be :

$$[[I] \mid \{\beta\}] \begin{Bmatrix} M_1 \\ \dots \\ M_2 \end{Bmatrix} = \{\alpha\} \quad (3-10)$$

where

$[I]$ = a unit matrix, $[(n+c) \times (n+v-1)]$
 $\{\alpha\}, \{\beta\}$ = the resulting submatrices after transformation

(f) For condition (iv), there are more unknowns than the number of equations in Equation (3-9) or Equation (3-10) so that the solutions can not be determined. Therefore, the solutions of this type of problem are designated as non-feasible solutions.

Example 1 is a one variable and one constraint plane truss problem which will explain the application of the Singular Imbedding Method for a type of displacement constraint.

Example 1 : The statically indeterminate truss is shown in figure below. Determine the property of member 3 such that the displacement at joint 4 in the x-direction is 0.0328 inches.

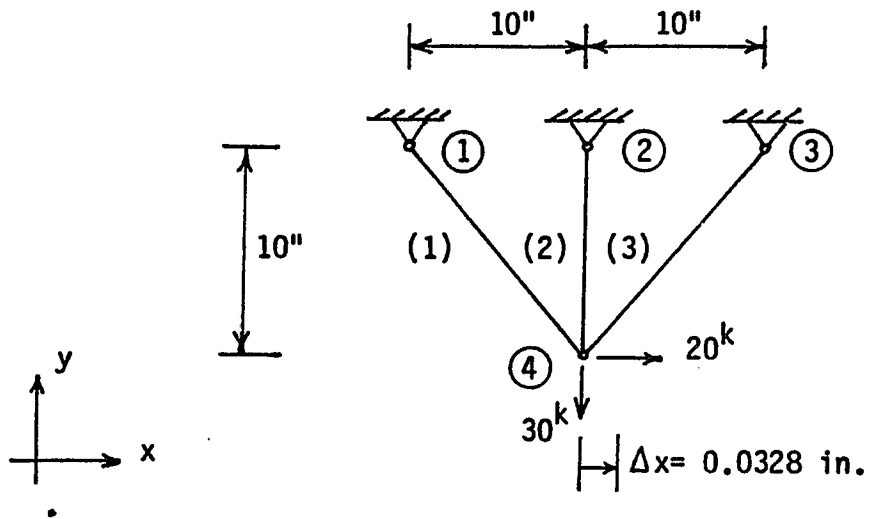

Design informations :

Member properties are $A_1 = 0.887$ in.²

$A_2 = 1.030$ in.²

Modulus of elasticity is $E = 10,000$ ksi.

Member 3 is a variable member

The constraint value $u_{x4} = 0.0328$ in.

Solution : Draw the network for this problem :

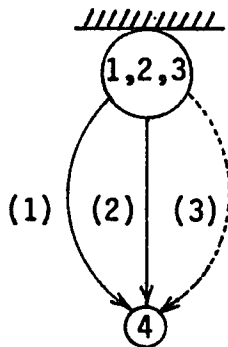

Network Graph

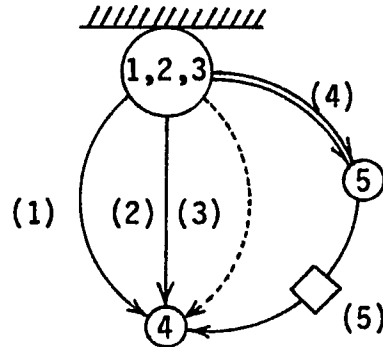

Adding Nullator To Constrain
Displacement

(a) The stiffness matrix of this problem is created by using Equation (2-35a). Hence

$$[K]_m = \begin{bmatrix} [K_1] & 0 & 0 & 0 & 0 \\ 0 & [K_2] & 0 & 0 & 0 \\ 0 & 0 & 0 & 0 & 0 \\ 0 & 0 & 0 & [K_4] & 0 \\ 0 & 0 & 0 & 0 & [0] \end{bmatrix}$$

where

$$[K_1] = \begin{bmatrix} 313.61 & -313.61 \\ -313.61 & 313.61 \end{bmatrix}$$

$$[K_2] = \begin{bmatrix} 0 & 0 \\ 0 & 1030 \end{bmatrix}$$

$$[K_4] = [\text{Arbitrary}]$$

From $[K] = AE/L$

for member 4, assume $A_4 = 1$ unit area

$$L_4 = 10\sqrt{2} \text{ in.}$$

Therefore

$$[K_4] = \frac{1 \times 10,000}{10\sqrt{2}} = [707.11]$$

(b) All member forces are transferred to nodal forces by using branch-node incidence matrix.

node \ branch	1,2,3	4	5
1		-1	0
2		-1	0
3		-1	0
4		0	-1
5		-1	1

$$[A^t] = \begin{bmatrix} -1 & -1 & -1 & 0 & -1 \\ 0 & 0 & 0 & -1 & 1 \end{bmatrix}$$

Submatrices $[[A^t][K_m][A]$ equals to

$$\begin{bmatrix} -1 & -1 & -1 & 0 & -1 \\ 0 & 0 & 0 & -1 & 1 \end{bmatrix}_{(2 \times 5)} \begin{bmatrix} [K_1]_{2,2} \\ [K_2]_{2,2} \\ 0 \\ [K_4]_{1,1} \\ 0 \end{bmatrix}_{(5 \times 5)} \begin{bmatrix} -1 & 0 \\ -1 & 0 \\ -1 & 0 \\ 0 & -1 \\ -1 & 1 \end{bmatrix}_{(5 \times 2)}$$

$$\begin{bmatrix} [K_1 + K_2]_{2,2} & 0 \\ 0 & [K_4]_{1,1} \end{bmatrix}_{(2 \times 2)}$$

where

$$\begin{aligned}
 [K_1 + K_2] &= \begin{bmatrix} 313.61 & -313.61 \\ -313.61 & 313.61 \end{bmatrix} + \begin{bmatrix} 0 & 0 \\ 0 & 1030 \end{bmatrix} \\
 &= \begin{bmatrix} 313.61 & -313.61 \\ -313.61 & 1343.61 \end{bmatrix}
 \end{aligned}$$

Therefore

$$[[A^t][K_m][A]] = \left[\begin{array}{cc|c} 313.61 & -313.61 & 0 \\ -313.61 & 1343.61 & 0 \\ \hline 0 & 0 & 707.11 \end{array} \right]$$

Substituting $[[A^t][K_m][A]]$ into Equation (3-4), yields

$$[[A^t][K_m][A]]\{u'\} = \{W\}$$

$$\left[\begin{array}{cc|c} 313.61 & -313.61 & 0 \\ -313.61 & 1343.61 & 0 \\ \hline 0 & 0 & 707.11 \end{array} \right] \begin{Bmatrix} u_{x4} \\ u_{y4} \\ u_{x5} \end{Bmatrix} = \begin{Bmatrix} 20 \\ -30 \\ 23.19 \end{Bmatrix}$$

$$\begin{aligned}
 \text{From Equation (2-30)} \quad P &= (707.11)(0.0328) \\
 &= 23.19
 \end{aligned}$$

(c) An applied member force is added into nodal equation.

node branch	3	4
3		-1

$$\text{From } [A_g^t] = (-1) \begin{bmatrix} \cos 225 \\ \sin 225 \end{bmatrix} = \begin{bmatrix} 1/\sqrt{2} \\ 1/\sqrt{2} \end{bmatrix}$$

$$\text{and } [A_g^t] \{P_g\} = \begin{bmatrix} 1/\sqrt{2} \\ 1/\sqrt{2} \end{bmatrix} \{P_{3x'}\}$$

hence, Equation (3-6) becomes

$$[[A_g^t] \mid [A^t][K_m][A]] \begin{Bmatrix} P \\ u' \end{Bmatrix} = \{W\}$$

$$\left[\begin{array}{ccc|c} 1/\sqrt{2} & 313.61 & -313.61 & 0 \\ 1/\sqrt{2} & -313.61 & 1343.61 & 0 \\ \hline 0 & 0 & 0 & 707.11 \end{array} \right] \begin{Bmatrix} P_{3x'} \\ u_{x4} \\ u_{y4} \\ u_{x5} \end{Bmatrix} = \begin{Bmatrix} 20 \\ -30 \\ \hline 23.19 \end{Bmatrix}$$

(d) According to the property of a DC system, u_{x4} equals to u_{x5} Equation (3-8) is shown as

$$\begin{bmatrix} 1/\sqrt{2} & -313.61 & 313.61 \\ 1/\sqrt{2} & 1343.61 & -313.61 \\ 0 & 0 & 707.11 \end{bmatrix} \begin{Bmatrix} P_{3x'} \\ u_{y4} \\ u_{x45} \end{Bmatrix} = \begin{Bmatrix} 20 \\ -30 \\ 23.19 \end{Bmatrix}$$

(e) From this problem, $c=v$, the final nodal equation is solved by

$$\begin{bmatrix} 1 & 0 & 0 \\ 0 & 1 & 0 \\ 0 & 0 & 1 \end{bmatrix} \begin{Bmatrix} P_{3x'} \\ u_{y4} \\ u_{x45} \end{Bmatrix} = \begin{Bmatrix} 5.862927 \\ -0.017759 \\ 0.032795 \end{Bmatrix} \quad (i)$$

From the force in member 3 is

$$\begin{aligned} [P'] &= [K]\{u'\} \\ \text{or } \{P_{3x'}\} &= [A_3 E/L \quad 0] \begin{bmatrix} 1/\sqrt{2} & 1/\sqrt{2} \end{bmatrix} \begin{Bmatrix} u_{x4} \\ u_{y4} \end{Bmatrix} \end{aligned}$$

$$P_{3x'} = 500 A_3 (u_{x4} + u_{y4}) \quad (ii)$$

Equation (i) and (ii) can be solved simultaneously, Hence

$$\begin{aligned} u_{x4} &= 0.0328 \quad \text{in.} \\ u_{y4} &= -0.0178 \quad \text{in.} \\ A_3 &= 0.779 \quad \text{in.}^2 \end{aligned}$$

3.3 Force Constraints

The method of Singular Imbedding is approached by adding FC (Force Constraining) systems into the network graph. The procedure of adding FC systems into the network graph is explained in chapter 2. The FC system is applied at the negative end of the member which is the constrained.

For a plane truss problem, the solutions are controlled as shown in Table 4.

Table 4

Force Or Stress Constraints Controlling Conditions

Condition	Controlling	Solutions
i	$v \leq c$	Solution is determined directly
ii	$v > 2$	Solution is in the feasible region
iii	unknowns > equations	Solution can not be determined

where v = number of variable members

c = number of force or stress constraints

Similar to the displacement constraint, the method of computation is based upon the stiffness method and network analysis. The Singular Imbedding Method is applied to a force constraint problem with the following general procedure :

(a) Generate the nodal equations for the defined members of the network graph. This equation will be in the form :

$$[[A^t][K_n][A]]\{u'\} = \begin{Bmatrix} W_1 \\ \dots \\ 0 \end{Bmatrix} \quad (3-11)$$

where

[A] = a branch-node incidence matrix associated with the geometry transformation in global coordinates

[K_n] = a global stiffness matrix for the defined members is shown in Equation (2-35b)

{u'} = joint displacements in global coordinates

{W₁} = a column matrix of applied joint loads in global coordinates

(b) Applied member forces are inserted in the nodal equation due to the force constraints. With each FC system, two vectors of applied forces are induced. {P₁} is a vector of the member forces which are transformed to applied joint loads in global coordinates and applied at the negative nodes of the variable members. A second

vector is the transformation of $\{P_1\}$ which equals a vector of constraining forces $\{W_2\}$ in global coordinates and is applied at the positive node of the norator. Therefore, variable members are included in the analysis explicitly as they are part of the FC system. Hence

$$[[A^t][K_n][A]]\{u'\} + [A_1^t]\{P_1\} = \begin{Bmatrix} W_1 \\ \dots \\ 0 \end{Bmatrix} \quad (3-12a)$$

$$[A_2^t]\{P_1\} = \{W_2\} \quad (3-12b)$$

Equation (3-12a) and (3-12b) are combined and partitioned into the following equation, which is similar to Equation (3-3) :

$$\left[\begin{array}{cc|c} [0] & [A_1^t] & [S_1] \\ \hline [A_2^t] & [0] & [0] \end{array} \right] \begin{Bmatrix} P_1 \\ \dots \\ u' \end{Bmatrix} = \begin{Bmatrix} W_1 \\ \dots \\ W_2 \end{Bmatrix} \quad (3-13)$$

where

$[A_1^t] = [A_2^t]$ = the branch-node incidence matrix associated with a geometrical transformation of the variable and ideal member, (2x1)

$\begin{Bmatrix} [S_1] \\ [0] \end{Bmatrix}$ = the new form of the global structural stiffness matrix which is combination of

$$[S_1] = [A^t][K_\eta][A] \text{ and a null matrix,} \\ [(2+2v) \times (2+2v)]$$

$\{P_1\}$ = a vector of member forces consisting of variable and ideal members, $(2v \times 1)$

$\{u'\}$ = joint displacements, $[(2+2v) \times 1]$

$\{W_1\}$ = applied joint loads, (2×1) for each node, e.g., if the applied joint loads are applied at nodes a, b, ..., z, $\{W_1\}$ becomes :

$$\left\{ \begin{array}{c} W_{1a} \\ W_{1b} \\ \cdot \\ \cdot \\ W_{1z} \end{array} \right\}$$

$\{W_2\}$ = an applied joint load due to the force constraint in a variable member in global coordinates, $(2v \times 1)$

v = number of variable members

(c) Equation (3-13) may be written as :

$$[[B_4] \mid [B_5]]_{dx} \cdot \{N\}_{ex1} = \{W'\}_{dx1} \quad (3-14)$$

where

$$[[B_4] \mid [B_5]] = \left[\begin{array}{cc|c} [0] & [A_1^t] & [S_1] \\ [A_2^t] & [0] & [0] \end{array} \right]$$

$$\{N\} = \text{the unknown variable matrix } \begin{Bmatrix} P_1 \\ \vdots \\ u \end{Bmatrix}$$

$$d = 2+2v$$

$$e = 2+4v$$

According to the assumption of the FC system, the displacement of the norator members is equal to zero. From Equation (2-37), the properties of norators affect the nodal equation by removing columns associated with the zero displacement from the stiffness matrix. Therefore, the matrix $[B_5]$ will be reduced to :

$$[[B_4] \ ; \ [B_6]]_{dx(e-2v)} \cdot \{N\}_{(e-2v) \times 1} = \{W\}_{dx1} \quad (3-15)$$

where

$[B_6]$ = the product of $[A^t][K_n][A]$ after adding the columns

According to Equation (2-39) and the equilibrium condition at the nodes (from the principle of network analysis), Equation (3-15) is reduced by the technique of adding rows. Hence :

$$[[B_7] \ ; \ [B_8]]_{2x(2+2v)} \{N\}_{(2+2v) \times 1} = \{W''\}_{2 \times 1} \quad (3-16)$$

where

$[B_7]$, $[B_8]$, $\{N\}$ and $\{W\}$ are the new matrices after adding the appropriate rows.

(d) Equation (3-16) is modified by using the Gauss-Jordan method. After applying this method, the result will be obtained as :

$$[[I] \mid \{\bar{\sigma}\}] \begin{Bmatrix} N_1 \\ \dots \\ N_2 \end{Bmatrix} = \{\mu\} \quad (3-17)$$

where

$[I]$ = a unit matrix, (2x2)

$\begin{Bmatrix} N_1 \\ \dots \\ N_2 \end{Bmatrix}$ = a vector of member forces in variable members and joint displacements

$\{\bar{\sigma}\}, \{\mu\}$ = the resulting submatrices after transformation

(e) For conditions (i) and (ii), Equation (3-17) will be solved directly by the rules of these conditions. If there are more unknowns than the number of equations, the solutions can not be determined. This is designated as condition (iii), and classified as the non-feasible solutions.

A one variable and one constraint plane truss problem is shown by Example 2, which will explain the application of the Singular Imbedding Method with an FC system.

Example 2 : The statically indeterminate truss is shown in figure below. Determine the property of member 3 such that the force in member 3 is ± 5.851 kips.

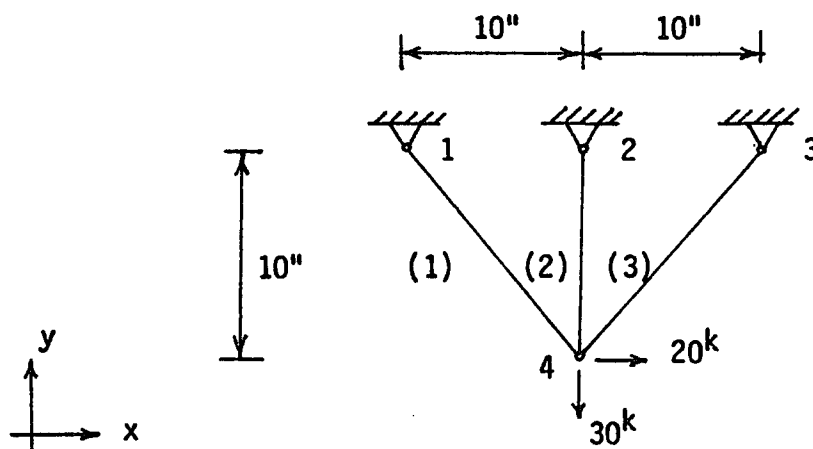

Design informations :

Member properties $A_1 = 0.887 \text{ in}^2$

$A_2 = 1.030 \text{ in}^2$

Modulus of elasticity is $E = 10,000 \text{ ksi}$.

Member 3 is a variable member

The constrained value $P_{3x} = \pm 5.851 \text{ kips}$.

Solution : Draw the network graph for this problem :

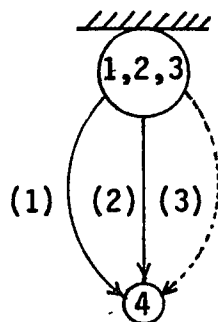

Network Graph

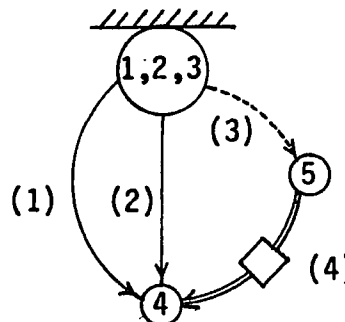

Adding Nodator To Constrain Force

(a) The stiffness matrix of this problem is created by using Equation (2-35b). Hence

$$[K]_n = \begin{bmatrix} [K_1] & 0 & 0 & 0 \\ 0 & [K_2] & 0 & 0 \\ 0 & 0 & 0 & 0 \\ 0 & 0 & 0 & [0] \end{bmatrix}$$

where

$$[K_1] = \begin{bmatrix} 313.61 & -313.61 \\ -313.61 & 313.61 \end{bmatrix}$$

$$[K_2] = \begin{bmatrix} 0 & 0 \\ 0 & 1030 \end{bmatrix}$$

(b) All member forces are transferred to be nodal forces by using branch-node incidence matrix.

node branch	1,2,3	4	5
1		-1	0
2		-1	0
3		0	-1
4		-1	1

$$[A^t] = \begin{bmatrix} -1 & -1 & 0 & -1 \\ 0 & 0 & -1 & 1 \end{bmatrix}$$

Submatrices $[[A^t][K_n][A]]$ equals to

$$\begin{bmatrix} -1 & -1 & 0 & -1 \\ 0 & 0 & -1 & 0 \end{bmatrix}_{(2 \times 4)} \begin{bmatrix} [K_1]_{2,2} & & & \\ & [K_2]_{2,2} & & \\ & & 0 & \\ & & & [0]_{2,2} \end{bmatrix}_{(4 \times 4)} \begin{bmatrix} -1 & 0 \\ -1 & 0 \\ 0 & -1 \\ -1 & 1 \end{bmatrix}_{(4 \times 2)}$$

$$\begin{bmatrix} [K_1 + K_2]_{2,2} & 0 \\ 0 & [0]_{2,2} \end{bmatrix}_{(2 \times 2)}$$

where

$$\begin{aligned} [K_1 + K_2] &= \begin{bmatrix} 313.61 & -313.61 \\ -313.61 & 313.61 \end{bmatrix} + \begin{bmatrix} 0 & 0 \\ 0 & 1030 \end{bmatrix} \\ &= \begin{bmatrix} 313.61 & -313.61 \\ -313.61 & 1343.61 \end{bmatrix} \end{aligned}$$

Therefore

$$[[A^t][K_n][A]] = \begin{bmatrix} 313.61 & -313.61 & 0 & 0 \\ -313.61 & 1343.61 & 0 & 0 \\ 0 & 0 & 0 & 0 \\ 0 & 0 & 0 & 0 \end{bmatrix}$$

Substituting $[[A^t][K_n][A]]$ into Equation (3-11), yields

$$[[A^t][K_n][A]]\{u'\} = \begin{Bmatrix} W_1 \\ \dots \\ 0 \end{Bmatrix}$$

$$\begin{bmatrix} 313.61 & -313.61 & | & 0 & 0 \\ -313.61 & 1343.61 & | & 0 & 0 \\ \hline 0 & 0 & | & 0 & 0 \\ 0 & 0 & | & 0 & 0 \end{bmatrix} \begin{Bmatrix} u_{x4} \\ u_{y4} \\ u_{y5} \\ u_{x5} \end{Bmatrix} = \begin{Bmatrix} 20 \\ -30 \\ 0 \\ 0 \end{Bmatrix}$$

(c) An applied member force is added into the nodal equation.

node	3	5
branch		
3		-1

node	4	5
branch		
4	-1	

From $[A_g^t] = (-1) \begin{bmatrix} \cos 225 \\ \sin 225 \end{bmatrix} = \begin{Bmatrix} 1/\sqrt{2} \\ 1/\sqrt{2} \end{Bmatrix}$

Equation (3-13) is recalled

$$\begin{bmatrix} [0] & [A_1^t] & | & [S_1] \\ [A_2^t] & [0] & | & [0] \end{bmatrix} \begin{Bmatrix} P_1 \\ \dots \\ u' \end{Bmatrix} = \begin{Bmatrix} W_1 \\ \dots \\ W_2 \end{Bmatrix}$$

where

$$\{P_1\} = \begin{Bmatrix} P_{3x'} \\ P_{4x'} \end{Bmatrix}$$

$$[A_1^t] \{P_{3x'}\} = \begin{bmatrix} 1/\sqrt{2} \\ 1/\sqrt{2} \end{bmatrix} \{P_{3x'}\}$$

$$[A_2^t] \{P_{4x'}\} = \begin{bmatrix} 1/\sqrt{2} \\ 1/\sqrt{2} \end{bmatrix} \{P_{4x'}\}$$

Hence

$$\left[\begin{array}{cc|cc|cc} 0 & 1/\sqrt{2} & 313.61 & -313.61 & 0 & 0 \\ 0 & 1/\sqrt{2} & -313.61 & 1343.61 & 0 & 0 \\ \hline 1/\sqrt{2} & 0 & 0 & 0 & 0 & 0 \\ 1/\sqrt{2} & 0 & 0 & 0 & 0 & 0 \end{array} \right] \begin{Bmatrix} P_{3x'} \\ P_{4x'} \\ \hline u_{x4} \\ u_{y4} \\ \hline u_{y5} \\ u_{x5} \end{Bmatrix} = \begin{Bmatrix} 20 \\ -30 \\ \hline 4.137 \\ 4.137 \end{Bmatrix}$$

(d) Due to the property of an FC system

$$u_{x4} = u_{x5} \quad \text{and} \quad u_{y4} = u_{y5}$$

and the equilibrium of the system, the process

of adding columns 3 and 6, 4 and 5

adding rows 1 and 3, 2 and 4

are combined. Hence

$$\left[\begin{array}{cc|cc} 1/\sqrt{2} & 1/\sqrt{2} & 313.61 & -313.61 \\ 1/\sqrt{2} & 1/\sqrt{2} & -313.61 & 1343.61 \end{array} \right] \begin{Bmatrix} P_{3x'} \\ P_{4x'} \\ \hline u_{x45} \\ u_{y45} \end{Bmatrix} = \begin{Bmatrix} 24.137 \\ -25.863 \end{Bmatrix}$$

(e) Switching columns 2 and 4, and using the Gauss-Jordan method this equation, yields :

$$\left[\begin{array}{cc|cc} 1 & 0 & 275.65165 & 1 \\ 0 & 1 & -0.378477 & 0 \end{array} \right] \begin{Bmatrix} P_{3x'} \\ u_{y45} \\ \hline u_{x45} \\ P_{4x'} \end{Bmatrix} = \begin{Bmatrix} 20.753728 \\ -0.030177 \end{Bmatrix} \quad (i)$$

From problem $P_{3x'} = P_{4x'} = 5.851$ kips. By using these values, Equation (i) will be solved simultaneously. Hence

$$u_{x45} = 0.032876 \quad \text{in.}$$

$$u_{y45} = -0.0177487 \quad \text{in.}$$

To determine the property of member 3, the basic of stiffness method is recalled

$$[P'] = [K]\{u'\}$$

$$\text{or } \{P_{3x'}\} = [A_3 E/L \quad 0] \begin{bmatrix} 1/\sqrt{2} & 1/\sqrt{2} \end{bmatrix} \begin{Bmatrix} u_{x4} \\ u_{y4} \end{Bmatrix}$$

$$P_{3x'} = 500 A_3(u_{x4} + u_{y4}) \quad (ii)$$

Substituting Equation (ii), yields

$$A_3 = 0.77357 \quad \text{in.}^2$$

3.4 Stress Constraints

This type of constraint problem is similar to the force constraint problem. According to the definition, stress is defined as equal to force per unit area. Hence, for an axial load :

$$\sigma = P/A \quad (3-18)$$

Equation (3-18) may be written as :

$$P = \sigma \cdot A \quad (3-19)$$

Considering Equation (3-19), one can transform a stress value to a force value. From this conceptual point of view, a stress constrained value can be transformed to a force constrained value. Therefore, a stress constrained problem is equivalent to a force constrained problem.

The method of Singular Imbedding is applied to a

stress constrained problem by adding an FC (Force Constraining) system into the network graph. The general procedure of computation is the same as the force constraint which is demonstrated in section 3.3 .

From Equation (3-12b), the matrix $\{W_2\}$ is a vector of constraining forces. Therefore, Equation (3-19) is applied to Equation (3-12b). One obtains :

$$\{W_2\} = [A_2^t] \{ \sigma_m A_m \} \quad (3-20)$$

where

σ_m = stress constraint in member m

A_m = a cross-sectional area of member m

In this thesis, the sign convention of forces and stresses are defined automatically by the coordinates. A free body diagram of a structure is drawn to locate member forces and directions. Therefore, the member forces or stresses are designated by tension or compression in the members.

Similarly, Example 3 is a two variables and two stresses constraint plane truss problem. The Singular Imbedding Method is applied to determine two unknowns member areas. The method for solving this problem is explained step by step.

Example 3 : The statically indeterminate truss is

shown in figure below. Determine the properties of member 2 and member 3 such that the stresses in members 2 and 3 are ± 17.742 and ± 7.55 ksi., respectively.

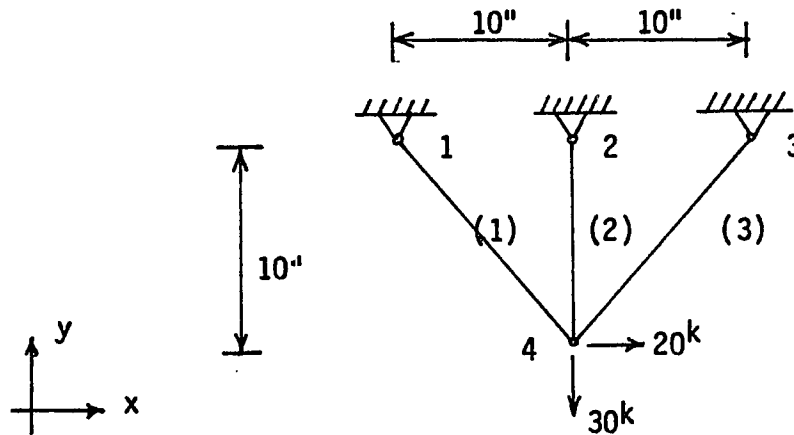

Design informations :

Member property $A_1 = 0.887 \text{ in}^2$
 Modulus of elasticity is $E = 10,000 \text{ ksi.}$
 Member 2 and 3 are the variable members
 The constrained values $\sigma_{2x'} = \pm 17.742 \text{ ksi.}$
 $\sigma_{3x'} = \pm 7.550 \text{ ksi.}$

Solution : Draw the network graph for this problem :

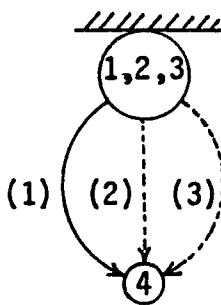

Network Graph

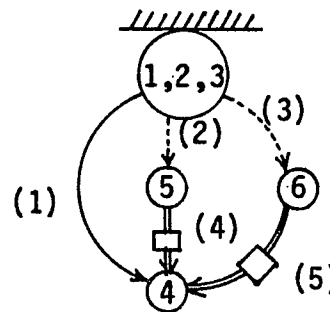

Adding Norator To Constrain Stresses

(a) The stiffness matrix of this problem is created by using Equation (2-35b). Hence

$$[K]_n = \begin{bmatrix} [K_1] & 0 & 0 & 0 & 0 \\ 0 & 0 & 0 & 0 & 0 \\ 0 & 0 & 0 & 0 & 0 \\ 0 & 0 & 0 & [0] & 0 \\ 0 & 0 & 0 & 0 & [0] \end{bmatrix}$$

where

$$[K_1] = \begin{bmatrix} 313.61 & -313.61 \\ -313.61 & 313.61 \end{bmatrix}$$

(b) All member forces are transferred to be nodal forces by using branch-node incidence matrix.

node branch	1,2,3	4	5	6
1		-1	0	0
2		0	-1	0
3		0	0	-1
4		-1	1	0
5		-1	0	1

$$[A^t] = \begin{bmatrix} -1 & 0 & 0 & -1 & -1 \\ 0 & -1 & 0 & 1 & 0 \\ 0 & 0 & -1 & 0 & 1 \end{bmatrix}$$

Submatrices $[[A^t][K_n][A]]$ equals to

$$\begin{bmatrix} -1 & 0 & 0 & -1 & -1 \\ 0 & -1 & 0 & 1 & 0 \\ 0 & 0 & -1 & 0 & 1 \end{bmatrix} \begin{bmatrix} [K_1]_{2,2} & & & & \\ & 0 & & & \\ & & 0 & & \\ & & & [0]_{2,2} & \\ & & & & [0]_{2,2} \end{bmatrix} \begin{bmatrix} -1 & 0 & 0 \\ 0 & -1 & 0 \\ 0 & 0 & -1 \\ -1 & 1 & 0 \\ -1 & 0 & 1 \end{bmatrix}$$

(3x5) (5x5) (5x3)

$$\begin{bmatrix} [K_1]_{2,2} & 0 & 0 \\ 0 & [0]_{2,2} & 0 \\ 0 & 0 & [0]_{2,2} \end{bmatrix} \quad (3x3)$$

Therefore

$$[[A^t][K_n][A]] = \begin{bmatrix} 313.61 & -313.61 & 0 & 0 & 0 & 0 \\ -313.61 & 313.61 & 0 & 0 & 0 & 0 \\ 0 & 0 & 0 & 0 & 0 & 0 \\ 0 & 0 & 0 & 0 & 0 & 0 \\ 0 & 0 & 0 & 0 & 0 & 0 \\ 0 & 0 & 0 & 0 & 0 & 0 \end{bmatrix}$$

Substituting $[[A^t][K_n][A]]$ into Equation (3-11),

yields

$$[[A^t][K_n][A]]\{u\} = \begin{Bmatrix} W_1 \\ 0 \end{Bmatrix}$$

$$\begin{bmatrix} 313.61 & -313.61 & 0 & 0 & 0 & 0 \\ -313.61 & 313.61 & 0 & 0 & 0 & 0 \\ \hline 0 & 0 & 0 & 0 & 0 & 0 \\ 0 & 0 & 0 & 0 & 0 & 0 \\ \hline 0 & 0 & 0 & 0 & 0 & 0 \\ 0 & 0 & 0 & 0 & 0 & 0 \end{bmatrix} \begin{Bmatrix} u_{x4} \\ u_{y4} \\ u_{x5} \\ u_{y5} \\ u_{x6} \\ u_{y6} \end{Bmatrix} = \begin{Bmatrix} 20 \\ -30 \\ 0 \\ 0 \\ 0 \\ 0 \end{Bmatrix}$$

(c) An applied member force is added into the nodal equation.

node	3	6
branch		
3		-1

node	4	6
branch		
5	-1	

node	2	5
branch		
2		-1

node	4	5
branch		
4	-1	

From $[A_g^t] = (-1) \begin{bmatrix} \cos 225 \\ \sin 225 \end{bmatrix} = \begin{bmatrix} 1/\sqrt{2} \\ 1/\sqrt{2} \end{bmatrix}$

$$\text{and} \quad [A_g^t] = (-1) \begin{bmatrix} \cos(-90) \\ \sin(-90) \end{bmatrix} = \begin{bmatrix} 0 \\ 1 \end{bmatrix}$$

Equation (3-13) is recalled

$$\left[\begin{array}{cccc|c} [0] & [A_3^t] & [0] & [A_1^t] & [S_1] \\ \hline [0] & [0] & [A_2^t] & [0] & [0] \\ \hline [A_4^t] & [0] & [0] & [0] & [0] \end{array} \right] \begin{Bmatrix} P_1 \\ u' \end{Bmatrix} = \begin{Bmatrix} W_1 \\ W_2 \\ W_3 \end{Bmatrix}$$

where

$$\{P_1\} = \begin{Bmatrix} P_{2x'} \\ P_{4x'} \\ P_{3x'} \\ P_{5x'} \end{Bmatrix}$$

$$[A_1^t]\{P_{5x'}\} = \begin{bmatrix} 1/\sqrt{2} \\ 1/\sqrt{2} \end{bmatrix} \{P_{5x'}\}$$

$$[A_2^t]\{P_{3x'}\} = \begin{bmatrix} 1/\sqrt{2} \\ 1/\sqrt{2} \end{bmatrix} \{P_{3x'}\}$$

$$[A_3^t]\{P_{4x'}\} = \begin{bmatrix} 0 \\ 1 \end{bmatrix} \{P_{4x'}\}$$

$$[A_4^t]\{P_{2x'}\} = \begin{bmatrix} 0 \\ 1 \end{bmatrix} \{P_{2x'}\}$$

Hence

$$\left[\begin{array}{cccc|cc} 0 & 0 & 0 & 1/\sqrt{2} & 313.61 & -313.61 & 0 & 0 & 0 & 0 \\ 0 & 1 & 0 & 1/\sqrt{2} & -313.61 & 313.61 & 0 & 0 & 0 & 0 \\ \hline 0 & 0 & 1/\sqrt{2} & 0 & 0 & 0 & 0 & 0 & 0 & 0 \\ 0 & 0 & 1/\sqrt{2} & 0 & 0 & 0 & 0 & 0 & 0 & 0 \\ \hline 0 & 0 & 0 & 0 & 0 & 0 & 0 & 0 & 0 & 0 \\ 1 & 0 & 0 & 0 & 0 & 0 & 0 & 0 & 0 & 0 \end{array} \right] \left\{ \begin{array}{l} P_{2x'} \\ P_{4x'} \\ P_{3x'} \\ P_{5x'} \\ \hline u_{x4} \\ u_{y4} \\ \hline u_{x5} \\ u_{y5} \\ \hline u_{x6} \\ u_{y6} \end{array} \right\} = \left\{ \begin{array}{l} 20 \\ -30 \\ \hline 5.339A_3 \\ 5.339A_3 \\ \hline 0 \\ 17.742A_2 \end{array} \right\}$$

(d) Due to the property of an FC system

$$u_{x4} = u_{x5} = u_{x6} \text{ and } u_{y4} = u_{y5} = u_{y6}$$

and the equilibrium of the system, the process of

adding columns 5 and 7 and 9, 6 and 8 and 10

adding rows 1 and 3 and 5, 2 and 4 and 6

are combined. Hence :

$$\left[\begin{array}{cccc|cc} 0 & 0 & 1/\sqrt{2} & 1/\sqrt{2} & 313.61 & -313.61 \\ 1 & 1 & 1/\sqrt{2} & 1/\sqrt{2} & -313.61 & 313.61 \end{array} \right] \left\{ \begin{array}{l} P_{2x'} \\ P_{4x'} \\ P_{3x'} \\ P_{5x'} \\ \hline u_{x456} \\ u_{y456} \end{array} \right\} = \left\{ \begin{array}{l} 20 + 5.339A_3 \\ -30 + 5.339A_3 + 17.742A_2 \end{array} \right\}$$

(e) Switching columns and using the

Gauss-Jordan method this equation yields,

$$\left[\begin{array}{cc|cc} 1 & 0 & 0 & 1 & 0.707088 & 0.707088 \\ 0 & 1 & -1 & 0 & 0.0015943 & 0.0015943 \end{array} \right] \left\{ \begin{array}{c} P_{3x'} \\ u_{y456} \\ \hline u_{x456} \\ P_{5x'} \\ P_{2x'} \\ P_{4x'} \end{array} \right\} = \left\{ \begin{array}{c} -7.070927 + 12.545434A_2 + 7.55A_3 \\ -0.0797168 + 0.0282867A_2 \end{array} \right\} \quad (i)$$

$$\begin{aligned} \text{From problem} \quad P_{3x'} &= P_{5x'} = 7.550A_3 \\ \text{and} \quad P_{2x'} &= P_{4x'} = 17.742A_2 \end{aligned}$$

By using these values, Equations (i) will be solved simultaneously. Hence

$$A_2 = -0.5636506 - 0.6018393A_3 \quad (ii)$$

$$(u_{y456} - u_{x456}) = -0.0797168 - 0.0282854A_2 \quad (iii)$$

From a member stiffness formula

$$[P'] = [K]\{u'\}$$

$$\text{or} \quad \{P_{2x'}\} = [A_2 E/L \quad 0][0 \quad -1] \left\{ \begin{array}{c} u_{x456} \\ u_{y456} \end{array} \right\}$$

$$\text{and } \{P_{3x'}\} = [A_3 E/L \quad 0] \begin{bmatrix} 1/\sqrt{2} & 1/\sqrt{2} \end{bmatrix} \begin{Bmatrix} u_{x456} \\ u_{y456} \end{Bmatrix}$$

Therefore

$$P_{2x'} = -1000 A_2 u_{y456}$$

$$\text{and } P_{3x'} = 500 A_3 (u_{x456} + u_{y456})$$

Substituting these values into Equation (ii) and (iii), yields

$$A_2 = -1.0299589 \quad \text{in}^2$$

$$A_3 = 0.7748054 \quad \text{in}^2$$

Note : A_2 is negative sign due to "Tension Member".

CHAPTER 4

ANALYSIS LIMITATIONS

4.1 Types Of Solutions

A method for solving different types of constraints was described in the previous chapter. A variable member with unknown member properties was used in the analysis, e.g., cross-sectional areas were determined. In this thesis, the method is developed and referred to as the Singular Imbedding Method. The method uses the structural stiffness equation to solve for the member forces in local coordinates and the joint displacements in global coordinates. From the member forces and joint displacements, an unknown member property is determined by using the member's local stiffness relationship. The solutions of these problems may be separated into two categories :

- (i) Feasible solutions under the imposed loads.
- (ii) Non-feasible solutions under the imposed loads.

The sign of the cross-sectional area obtained from the solution using the member stiffness equation designates whether the solution is practical or not.

4.2 Feasible Solutions

The values of unknown variable members are solved by using the member's local stiffness relationship and the joint displacements. Both positive and negative values for the cross-sectional area of variable members are found. The physical interpretation for each condition is discussed. Example 1 (chapter 3) is used to illustrate the two categories.

$$\begin{aligned}
 P_{3x1} &= 5.86 && \text{kips.} \\
 A_3 &= 0.779 && \text{in.}^2 \\
 u_{x4} &= 0.0328 && \text{in.} \\
 u_{y4} &= -0.0178 && \text{in.}
 \end{aligned}$$

This type of solution may be classified as :

(i) A practical solution is a positive sign for all variable members (cross-sectional area) represents this type of solution.

(ii) A non-practical solution or a prestressed condition is represented by a negative sign for a variable member. In the physical meaning, structural members must be prestressed with either a tension or compression force before applying the external loads. Example 1 (chapter 3) is solved by changing :

(a) The constraint value u_{x4} from 0.1 to 5.0 inches.

The solution of this problem is :

$$\begin{aligned}
 P_{3x} &= -1363.23 && \text{kips.} \\
 A_3 &= -0.3973 && \text{in.}^2 \\
 u_{x4} &= 5.0 && \text{in.} \\
 u_{y4} &= 1.8625 && \text{in.}
 \end{aligned}$$

The deformed shape for this problem is shown in Figure 19. The physical meaning of this solution is that member (3) has a prestressed tensile force of 1363.23 kips. The external loads at node (4) in the x- and y-directions are 20 and 30 kips, respectively. An additional tensile force in member (3) is required to meet the constraint condition. This force must be prestressed in member (3) before applying the external loads, which is not common in conventional construction. Although the solutions can be determined by the Singular Imbedding Method, the results are considered non-practical.

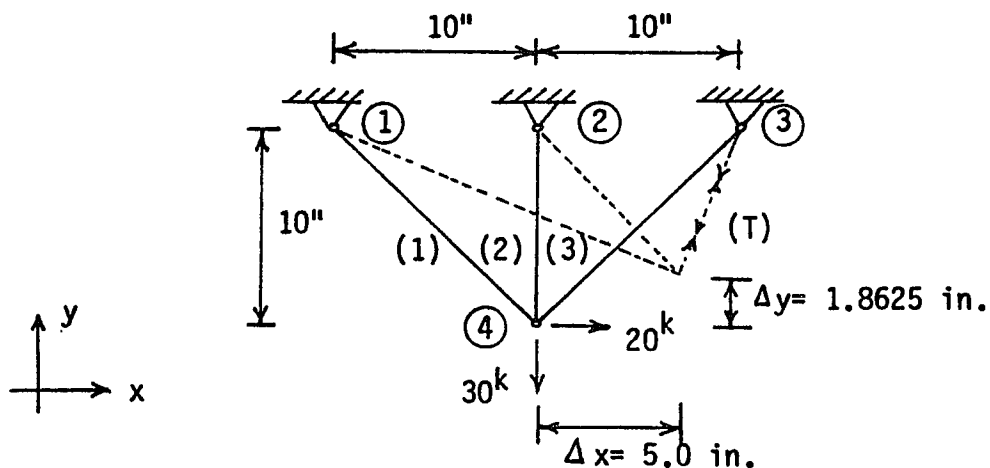

FIG. 19 Deformation Shape

Let us consider the prestressing condition, the deformation of this physical condition may be described by using superposition as shown in Figure 20.

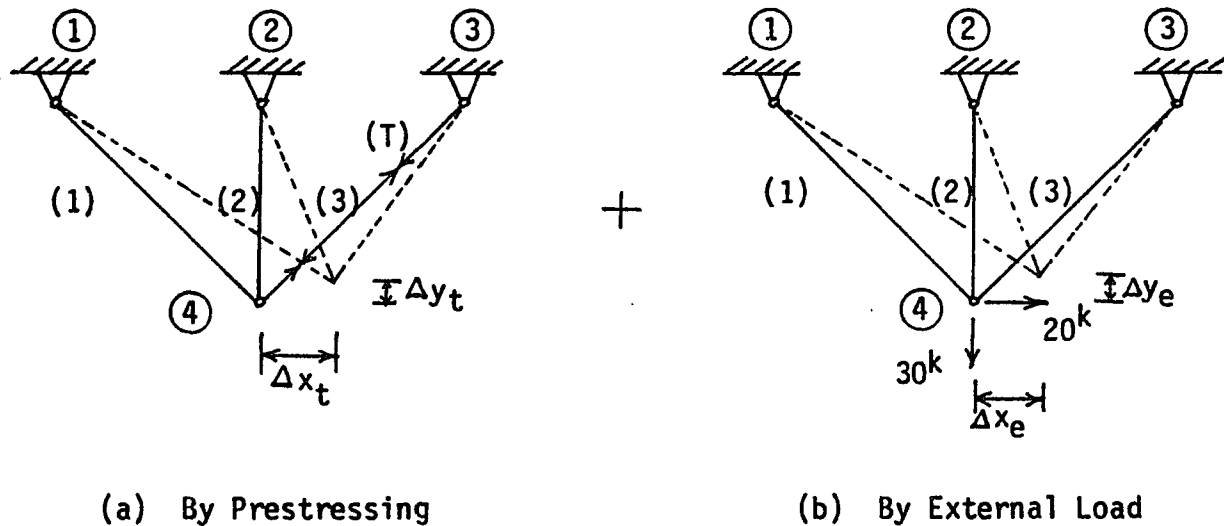
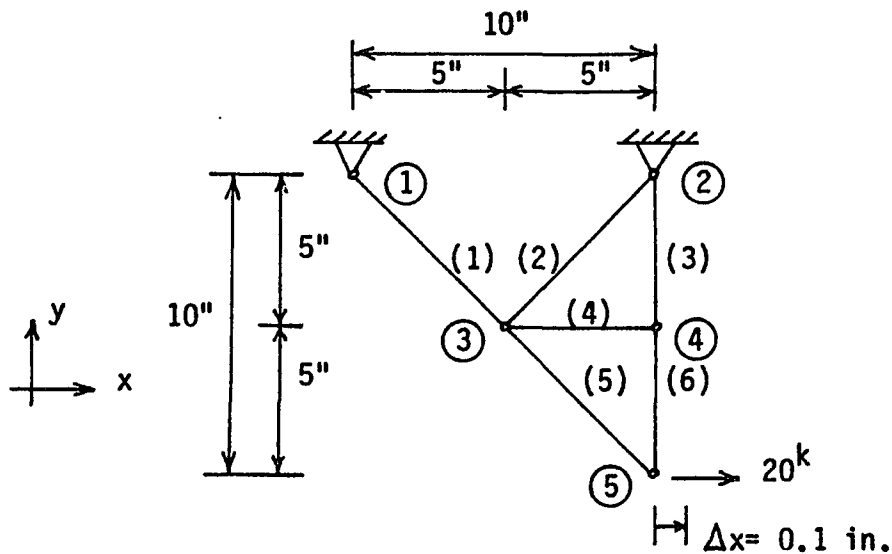

FIG. 20 Superposition Method Of Deformation

4.3 Non-Feasible Solutions

This type of solution is physically impossible. From a mathematical point of view, the solution may be represented by an "Infinity Value". In the physical condition, this phenomenon can be described by the statement, no matter how much force is prestressed in the variable member, the unknowns can not be solved to meet the specified requirements. Example 4 is an example of this type of solution.

Example 4 : The statically determinate truss is shown in figure below. Determine the property of member (4) such that the displacement at joint 5 in the x-direction is 0.1 inches.



Design informations :

Member properties are $A_1 = A_2 = A_5 = 0.95 \text{ in.}^2$

$A_3 = A_6 = 1.25 \text{ in.}^2$

Modulus of elasticity is $E = 10,000 \text{ ksi.}$

Member (4) is a variable member

The constraint value $u_{x5} = 0.1 \text{ in.}$

Solution : Applying the Singular Imbedding analysis, one obtains a set of four equations and six unknowns. Thus, there is no solution. If any other member had been selected as variable, a practical solution may be obtained.

CHAPTER 5

DISCUSSIONS AND CONCLUSIONS

5.1 Discussions

In this thesis, the Singular Imbedding Method is used to analyze a truss with joint displacement, member force, and member stress constraints. It is modified from a network graph by adding pseudo systems, i.e., DC (Displacement Constraining) systems, and FC (Force Constraining) systems. A DC system is used to constrain joint displacements, and an FC system is used to constrain forces or stresses in members. The structural stiffness matrices is developed to include defined members and pseudo systems. This structural stiffness matrix develops a singular matrix which must be modified before analysis can be completed (a matrix that can not be inverted).

As described in chapter 3, the singularity is subsequently handled by adding selected rows or columns of the matrix relating to the pseudo constraint systems. For a joint displacement constraint, the technique of adding the appropriate columns of the global structural stiffness matrix is developed. For a member force

constraint problem a row and a column of the global structural stiffness matrix is added. In the case of a member stress it can be transformed into terms of a member force by its definition.

Generally, the analysis in this thesis is modified from the network method by adding the pseudo systems to avoid the usual iterative analysis. To analyze and design statically indeterminate structures with specified constraints, the initial member properties must be assumed in the network analysis. After that the results (i.e., joint displacements, member forces, and member stresses) will be determined and compared with a set of specified requirements, until a feasible solution is reached.

Network analysis methods for structural analysis is developed along the lines of the traditional stiffness matrix method. The node method of network analysis is basically the same as stiffness matrix method of structural analysis. The formulation and calculation are similar to each other. A branch-node incidence matrix $[A]$ associated with a network analysis is conceptually the same as a member incidence matrix in the displacement method (e.g., $\{P\} = [A^t][K][A]\{u\}$) as described in chapter 1.

5.2 Conclusions

From chapters 2 and 3, the Singular Imbedding

Analysis is considered to be a convenient method with which to analyze or design structures to meet specified requirements, (i.e., joint displacements, member forces or member stresses). This method is a direct method of solution which allows one to avoid using an iterative analysis. Therefore, it will reduce the computational time.

In the case of displacement constraints, the structure is confined by an amount of displacement at one joint relative to another joint. In other words, that joint can be moved within specified limits. Given the properties of certain parts of the structure (defined members) and designating other members as variable, the Singular Imbedding Method is used to analyze a structure. The unknowns of the variable members are determined from the final structural stiffness matrix equation. Therefore, the structural members are selected to meet the constraints of the problem.

For a force constraint, forces in selected members are constrained by a specified amount. There are several types of member forces that might be constrained :

(i) Temperature effects; the members of the structure are affected by temperature changes, in terms of elongation and shrinkage.

(ii) Member forces; a structural member is allowed to only develop a force within a range specified by the designer.

Given the properties for the defined members in the structure and using force constraints, the Singular Imbedding Method is used to analyze and determine the properties of the variable members in the structure. Hence, the structural members are designed to meet the constrained conditions.

For a stress constraint, a structural member is limited by an amount of stress. A member stress can be transformed into terms of a member force by its definition. Therefore, the types of member stress constraints are similar to member force constraints. The Singular Imbedding Method is used to analyze a structure in the same way as for a force constraint problem.

The analysis limitations of the Singular Imbedding Method were described in chapter 4. In a design, only a practical solution is desirable in designing a structure to meet specified requirements. Therefore, the Singular Imbedding Analysis is an attractive method by which to design a structure. Given the properties for selected parts of the structure and allowing the rest of the structural members to be variable, the unknowns of structural members can be solved without iteration. One advantage of this method is that a direct solution can be found by the creation of a final structural stiffness matrix equation for each type of constraint condition.

The Singular Imbedding Method can be extended to handle other types of structures such as planar frames,

space frames, grids, and space trusses. More over, the types of constraints can be extended to inequality constraints, e.g., a displacement or a member force constraint is restricted within a range. Using an inequality constraint, an optimal solution can be obtained. For example, a statically indeterminate truss with all members treated as variable is considered as a displacement constrained problem. After the Singular Imbedding Method is applied to this problem, the solution is in the form of unknown member areas within a feasible region. If one minimum member area is known, the rest of them can be calculated as the minimum criterion. Therefore, these member areas will lead to an optimum truss design.

APPENDIX A

COORDINATE TRANSFORMATION

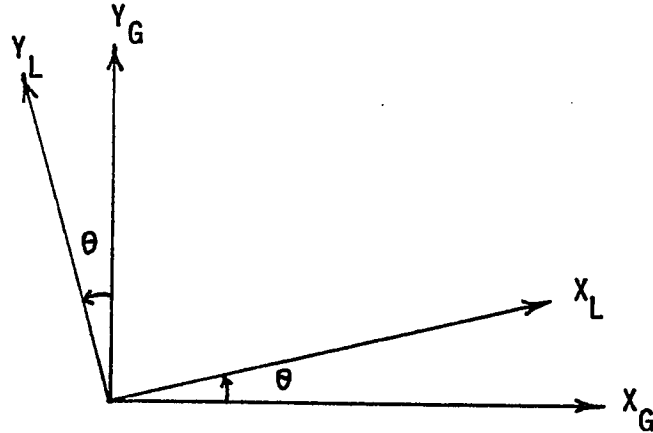

Let $X_L - Y_L$ are a local coordinate

$X_G - Y_G$ are a global coordinate

θ is an angle from global to local coordinates

The coordinated transformation matrix is :

$$[T] = \begin{bmatrix} \cos\theta & \sin\theta & 0 \\ -\sin\theta & \cos\theta & 0 \\ 0 & 0 & 1 \end{bmatrix}$$

For plane trusses, this matrix is reduced to :

$$[\tilde{T}] = \begin{bmatrix} \cos\theta & \sin\theta \\ -\sin\theta & \cos\theta \end{bmatrix}$$

APPENDIX B

ALGEBRAIC PROPERTIES OF NETWORKS

An arbitrary number is assigned to each mesh of the graph which is designated by $\{p'\}$. The operation $[C]\{p'\}$ will then induce the assignment of a relate set of numbers to the branches according to the equation :

$$\{p\} = [C]\{p'\} \quad (1)$$

where

$\{p\}$ = the set of derived branch quantities, (bx1)
 $[C]$ = a branch mesh matrix, (bxm)
 $\{p'\}$ = an arbitrary number assigned to each mesh of the graph, (mx1)

b = a number of branches

m = a number of meshes

The operation $[A^t]\{p\}$ will then induce the assignment of zero to the (non-datum) nodes since $[A^t][C] = 0$. Thus

$$[A^t]\{p\} = [A^t][C]\{p'\} = 0\{p'\} = 0 \quad (2)$$

In order to prove that $[A^t][C] = 0$, it will suffice to show that

$$(A_i, C_j) = 0 \quad \text{for all } i, j \quad (3)$$

where

$$\begin{aligned} A_i &= i^{\text{th}} \text{ column of } [A] \\ C_j &= j^{\text{th}} \text{ column of } [C] \end{aligned}$$

A has nonzero elements only in those rows which correspond to branches incident on the i -th node. And C_j has nonzero elements only in those rows that correspond to branches included in the j -th mesh. Therefore, if the i^{th} node is not incident on any of the branches in the j mesh, $(A_i, C_j) = 0$.

APPENDIX C

DESIGN AID FOR FRAMED STRUCTURE: SINGULAR IMBEDDING APPROACH⁽¹⁴⁾

The objective of this study is to use a technique called singular imbedding, proposed for the design of electrical circuits in structural design problems. The problems considered in this work are the design of elastic framed structures. Primary focus in using this technique will be the problem of designing structures to meet specified requirements, namely, joint displacements or member forces. These requirements can be either the constraints placed on a problem by a designer or the limits specified by codes or other specifications.

The singular imbedding approach is initiated by imposing singular elements representing constraints or limits placed upon the problem into the network graph representing a structure. If all members in the structure are specified, i.e., have known properties, placing singular elements on a network will lead to an inconsistency and no solution is possible. Selected members in the structure are labeled as variable members. These variable members will have their properties, namely,

cross-sectional area and moment of inertia, designed according to the specified constraints. Member forces in the variable members are then considered as applied member forces explicitly added to the nodal equations.

The following procedures are performed in the singular imbedding approach :

1. The singular elements (or the constrained elements are added into the network and will cause the structural stiffness matrix to be singular) are imbedded and variable members designated in the network graph representing the structure;

2. The structural stiffness matrix is written for the specified members with the nullators (is defined as an element which allows only zero displacement and force to occur, and used to show the relationship between nodes) remove;

3. The loads representing the variable members are added to the nodal equations;

4. The nodal equations are appended with the set of constraint equations.

The constraint equations applied to structural design problems are developed as :

a) Joint Displacements - Let u_0^* , u_1^* , and u_2^* be the constrained values of the joint displacement components. The equality equation is :

$$u_{i,m}^* = u_0^* \quad (1)$$

where

i is the joint at which displacements are constrained.

m is the component of the constrained displacement.

the following inequality equation is :

$$u_{i,m} \geq u_i^* \quad (2a)$$

or

$$u_{i,m} \leq u_2^* \quad (2b)$$

b) Member Forces - Let the values of the constraints be P_0^* , P_1^* , and P_2^* for the member force components. If the member considered is a variable member, the following equality equation applies :

$$P_{g,m} = P_0^* \quad (3)$$

where

g is the member in which member force is constrained.

m is the component of the constrained force.

For each inequality constraint, the equation is :

$$P_{g,m} \geq P_1^* \quad (4a)$$

or
$$P_{g,m}^* \leq P_2^* \quad (4b)$$

If the member considered is a defined member, the following equality equation applies for each equality constraint :

$$[(k_{gg})(a_g)]_m u' = P_0^* \quad (5)$$

where

k_{gg} is the member stiffness submatrix written for member g , in member coordinates.

a_g is the g row of the branch-node incidence matrix of a graph.

For each inequality constraint, the following inequality equation is :

$$[(k_{gg})(a_g)]_m u' \geq P_1^* \quad (6a)$$

or
$$[(k_{gg})(a_g)]_m u' \leq P_2^* \quad (6b)$$

From Equations (1) to (6), constraints were presented both equality and inequality constraints. By adding these equalities and/or inequalities to the nodal equations, the specified constraints are explicitly included in the analysis. The general procedure of the

singular imbedding approach can now be described as follows :

1. Generate the nodal equations for that portion of the structure which does not contain variable members as :

$$[A_0^t K_0 A_0] \{u'\} = \{P'\} \quad (7)$$

where A_0 and K_0 are written only for the defined members.

2. Add member forces in variable members to the nodal equation by describing them as the unknown applied forces, P_v . By adding these applied member forces to the nodal equations, the variable members are included in the analysis explicitly.

The nodal equations become :

$$[A_0^t K_0 A_0] \{u'\} = \{P'\} - [A_v^t] \{P_v\} \quad (8a)$$

adding $A_v^t P_v$ to both sides, the equations are :

$$[A_v^t : A_0^t K_0 A_0] \begin{Bmatrix} P_v \\ u' \end{Bmatrix} = \{P'\} \quad (8b)$$

3. Add the constraint equations and/or inequalities to Equation (8b), yields

$$\left[\begin{array}{c|c} A_v^t & A_0^t K_0 A_0 \\ \hline \alpha & \beta \end{array} \right] \begin{Bmatrix} P_v \\ u \end{Bmatrix} = \begin{Bmatrix} P' \\ \gamma \end{Bmatrix} \quad (9)$$

where the added terms

$[\alpha \mid \beta] \begin{Bmatrix} P_v \\ u \end{Bmatrix} \geq \begin{Bmatrix} \gamma \end{Bmatrix}$ represents the constraint equations and/or inequalities

α, β are partitioned matrices representing coefficients of the unknown variables P and u , respectively

γ is the vector of constant values of the constraint equalities and/or inequalities.

Equation (9) is the final design equation in which the variable members are designed according to the specified constraints. By solving this equation, the force-displacement relations of the variable members are determined. From these relations, variable member properties are calculated through the member stiffness equations for each member.

Note : A_0 = Branch-node incidence matrix for the graph
of defined structural members

A_v = Branch-node incidence matrix for the graph

of variable structural members

K_0 = Diagonal matrix of member stiffness matrices
of structural members

P = Vector of member forces

P_v = Vector of member forces in variable members

P^* = Vector of joint loads

$*$ = Constrained values

BIBLIOGRAPHY

1. Au, Tung, and Stelson, T.E., Introduction To Systems Engineering, Deterministic Model, Addison-Wesley Publishing Company, Reading, Massachusetts, 1969
2. Branin, F.H., Jr., " D-C And Transient Analysis Of Networks Using A Digital Computer ", IRE International Convention Record, Part 2, 1962, 236-256
3. Branin, F.H., Jr., " D-C Analysis Portion Of PE TAP-A Program For Analyzing Transistor Switching Circuits ", Technical Report 701, IBM Development Lab., Poughkeepsie, New York, 1960
4. Branin, F.H., Jr., " The Relation Between Kron's Method And The Classical Methods Of Network Analysis ", IRE WESCON Convention Record, Part 2, 1959, 3-28
5. Director, S.W., Circuit Theory A Computational Approach, John Wiley & Sons, New York, 1975
6. Fenves, S.J., and Branin, F.H., Jr., " Network-

Topological Formulation Of Structural Analysis ",
Structural Division ASCE, v89 (August, 1963), 483-512

7. Fenves, S.J., " Structural Analysis By Networks,
Matrices, And Computers ", Structural Division ASCE,
v92 (February, 1966), 199-221
8. Fenves, S.J., and Mauch, S.P., " Releases And
Constraints In Structural Networks ", Structural
Division ASCE, v93 (October, 1967), 401-417
9. Gallagher, R.H., Finite Element Analysis
Fundamentals, Prentice-Hall, Englewood Cliffs,
New Jersey, 1975
10. Gutkowski, R.M., Structures Fundamental Theory And
Behavior, Van Norstrand Reinhold Company, New York,
1981
11. Kron, G., " A Method To Solve Very Large Physical
Systems In Easy Stages ", Proceedings, IRE, v42,
1942, 680-686
12. Kozemchak, E.B., and Murray-Lasso, M.A., " Computer-
Aided Circuit Design By Singular Imbedding ", Bell
System Technical Journal, v48 (January, 1969),
275-315

13. Pian, Louis de, Linear Active Network Theory,
Prentice-Hall, Englewood Cliffs, New Jersey, 1962
14. Sangtian, W., " Design Aid For Framed Structure :
Singular Imbedding Approach ", Ph.D. thesis, Carnegie-
Mellon University, 1976
15. Spillers, W.R., " Network Analogy For The Truss
Problem ", Engineering Mechanics Division, ASCE, v88,
No. EM6, December, 1962
16. Spillers, W.R., " Network Analogy For Linear
Structures ", Engineering Mechanics Division, ASCE,
v89, No. EM4, August, 1963
17. Spillers, W.R., and Di Maggio, F.L., " Network
Analysis Of Structures ", Engineering Mechanics
Division, ASCE, v91, No. EM3, June, 1965
18. Wang, C.K., Matrix Methods Of Structural Analysis,
International Textbook Company, Scranton,
Pennsylvania, 1966
19. Willems, N., and Lucas, W.M., Jr., Matrix Analysis
For Structural Engineers, Prentice-Hall, Englewood
Cliffs, New Jersey, 1968