

CHAPTER 46

TURBULENCE AND SEDIMENT CONCENTRATION DUE TO WAVES

Kiyoshi Horikawa
Professor
and
Akira Watanabe
Postgraduate

Department of Civil Engineering
University of Tokyo
Tokyo, Japan

ABSTRACT

A new electrolytic turbulence transducer has been developed in order to measure the turbulent velocity fluctuation superposed on the oscillatory flow velocity. The aim of the present paper is firstly to describe the outline of this transducer and secondly to introduce some of the experimental results. The main items of the results are, 1) the vertical distribution of turbulence intensity averaged over one wave cycle, where the turbulence is induced by ripples which appear on the movable bed of wave flume, and 2) the correlation between the turbulence intensity and the characteristics of sediment particles at the same level such as their fall velocity and sediment concentration.

INTRODUCTION

The authors have had a strong interest in the fundamental mechanism of suspended sediment due to wave action. In the previous papers the authors have described their results related to the following subjects:

- 1) The vertical distribution of suspended sediment concentration due to waves (Hom-ma and Horikawa, 1962, Hom-ma, Horikawa and Kajima, 1965),
- 2) The general relationships to determine the size of sand ripples which appear on the movable bed owing to progressive waves (Hom-ma and Horikawa, 1962),
- 3) The critical water depth for the onset of bed material movement due to waves (Horikawa and Watanabe, 1967), and
- 4) The measurement of velocity distribution in the vicinity of bottom boundary in the oscillatory flow field, from which the characteristics of shear stress and of eddy viscosity been evaluated (Horikawa and Watanabe, 1968)

All of these studies are successive approaches to clarify the basic mechanism of suspension phenomena in a wave field

The following equation is commonly used as the fundamental equation for determining the vertical distribution of suspended sediment concentration averaged over one wave cycle \bar{m}

$$\frac{d}{dz} (K_z \frac{d\bar{m}}{dz}) + w_o \frac{d\bar{m}}{dz} = 0 \quad (1)$$

Where w_o is the fall velocity of suspended sediment particle, K_z is the vertical eddy diffusivity, and z is the vertical axis taken upward from the bottom. In order to solve the above equation the value of K_z should be evaluated beforehand, hence in the previous papers the authors treated the above problem based on the assumption that K_z could be replaced by the eddy viscosity ϵ_m . This kind of treatment should be valuable from the engineering point of view, but may not be powerful to clarify the basic questionnaires on the suspension phenomena, such as how to determine the concentration at a certain elevation near bottom which is used as a measure to define the vertical distribution of suspended sediment concentration.

In the region where the sediment movement is active, the flow in the vicinity of sea bottom is, generally speaking, in the turbulent flow condition, and the vortices are generated behind sand ripples which are formed along the sea bottom. These vortices induce the turbulence with higher frequencies in the oscillatory flow field. These processes stated above must keep the motivative activities on suspension phenomena, hence it seems to be of essential importance to clarify the turbulence characteristics in an oscillatory flow field in order to understand the real state of questioned phenomena.

ELECTROLYTIC TURBULENCE TRANSDUCER (ELET)

In order to measure the mean velocity in an oscillatory flow field, Jonsson(1963) applied a miniature current meter, while Iwagaki(1969) applied a hot-film anemometer. On the other hand the authors(1968) used the hydrogen bubble technique to measure the velocity in a thin boundary layer.

With regard to the turbulence in an oscillatory flow no data is available to be used. The main reasons why the measurement of turbulent velocity fluctuation in the vicinity of bottom boundary under the oscillatory flow is difficult are as follows.

- 1) The direction and magnitude of the main flow in the oscillatory flow field vary in time differing from the states of steady flow field.
- 2) The time variation of flow circumstance has been occurred in a rather short period such as one to several sec.

3) In the case of rippled rough bottom, a vortex with relatively big size (the diameter of vortex being one to several cm in laboratory) has been formed behind each ripple. Under these complicated situations it is awfully difficult to apply such a standardized measuring technique for obtaining each component of turbulent velocity fluctuation as a measurement of hot-film anemometer, the reliability of which has been verified in steady water flow. Binder (1967) reported the applicability of the electrokinetic turbulence meter, the principle of which is to measure the electric potential fluctuations induced by the translation of electric double layers. The disadvantage of this transducer is represented by the fact that the output is zero under the laminar flow condition. That is to say, the output is affected by the flow characteristics even though the current velocity is the same.

From these points of view the authors have been devoting their efforts to develop a new electrolytic turbulence transducer, herein after the authors will call it shortly as ELETT, and have a confidence in getting reliable data by using ELETT.

Figure 1 shows the schematic diagram of the instrumentation system. When the D.C. voltage is charged between a cathode of platinum wire and an anode of carbon rod, both of which are immersed in water, some part of water neighbouring those is electrolyzed to ions or gases. The flow produces a variation in electric resistance between the electrodes. Therefore the out-of-balance electric current in the Wheatstone's bridge is affected by the flow velocity at the cathode. The actual length of sensing element is about 1 mm.

In Figure 2 is shown the calibration curve between the velocity V and the output of sensor I. Figure 3 shows the direction-sensitivity $M(\varphi)$ of the ELETT sensor, where φ is the angle between the flow and a certain direction normal to the sensor.

When a probe which consists of a pair of sensors as shown in Figure 1 is used, the ratio between the output from one sensor and that from the other depends on the flow direction.

Table 1 is to summarize the processes how to determine the velocity component in a certain direction. The output I is a function of the velocity V and the direction angle φ , and is likely to be separated into two independent functions $S(V)$ and $M(\varphi)$ as shown in Equation (1). The calibration curves for $S(V)$ and $M(\varphi)$ are given as shown in the previous Figures 2 and 3. By using Figure b in Table 1, a newly defined function of $K(\varphi)$ can be calculated as shown in Figure c. The absolute value of V , the velocity component U , the direction angle φ , and the outputs I_1 and I_2 are defined as given in the stated diagram. Hence the outputs I_1 and I_2 are written as Equations (11) and (111) respectively, and the output ratio I_1/I_2 is expressed by the stated relation in Table 1. From Figure c the absolute value of direction angle $|\varphi|$ is deter-

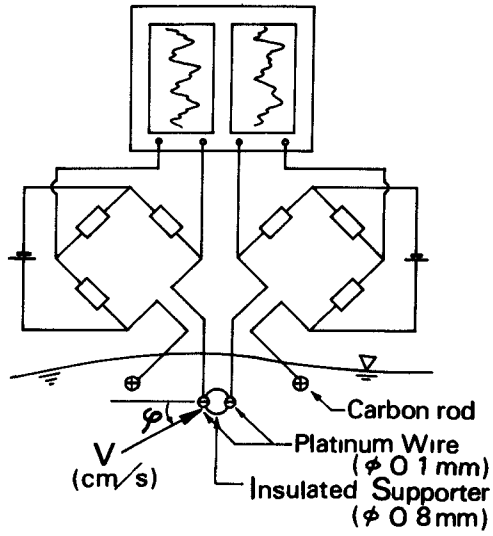

Fig. 1 Instrumentation system for velocity measurement.

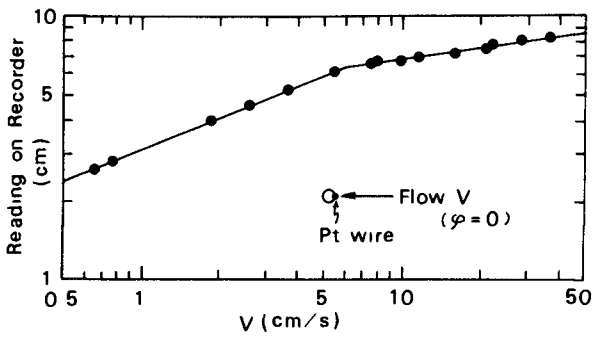

Fig. 2. Calibration curve for ELETT

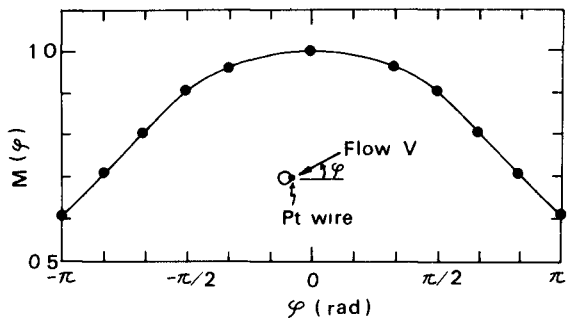

Fig 3 Direction-sensitivity of ELET

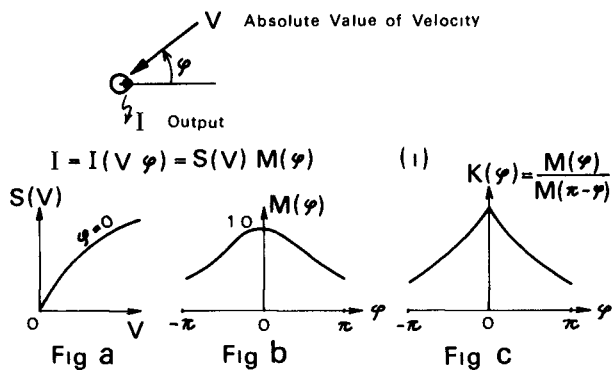
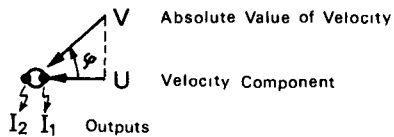

Fig a

Fig b

Fig c



$$I_1 = S(V) M(\varphi) \quad (ii)$$

$$I_2 = S(V) M(\pi - \varphi) \quad (iii)$$

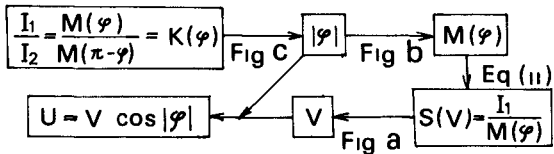

Table 1 Process diagram of velocity component reduction

mined By using Figure b we can get $M(\varphi)$, from which the value of $S(V)$ can be read by the help of Equation(11) Next the absolute value of V can be obtained by using Figure a, and hence the value of U is also calculated

TURBULENCE CHARACTERISTICS MEASURED BY ELETT

The laboratory measurements by ELETT was conducted in a wave flume under the following conditions the water depth was 30 cm, the wave height and period of fundamental mode were 7.93 cm and 1.35 sec respectively, and the water temperature was 8 °C The medium diameter and the sorting coefficient of standard sand placed on the flume bed with the thickness of 15 cm were 0.20 mm, and 1.15 respectively The rise and pitch of ripples which appeared on the flume bottom were 0.95 cm and 5.7 cm respectively

Figure 4 indicates one example of the time history of the horizontal velocity component which was measured by ELETT The thick line in this figure is for the measured horizontal velocity component U . Here it is necessary to separate the turbulence fluctuation from the combined original record In the present case of laboratory experiment, it was found that the amplitude of the second harmonic of surface wave profile was as small as 3 % of the fundamental mode, through the harmonic analysis of the wave record Hence the authors defined temporarily the turbulence velocity fluctuations u as the remainder after subtracting the fundamental mode of the velocity U_1 from the corresponding original data of horizontal velocity U In Figure 4 the fundamental mode velocity was expressed by a thin line, while the turbulence velocity fluctuation defined above was expressed by a broken line The same procedure was applied to the vertical velocity component.

Figure 5 shows the amplitude ratio between the calculated value of the vertical velocity component on the basis of Airy's theory W_{cal} and the fundamental mode value of the measured vertical velocity component W_{meas} . This diagram indicates that there exists a vertical motion in a considerably large scale even within a region near the bottom boundary For example $W_{meas} \approx 2$ cm/sec at $z \approx 0.5$ cm According to the oscillatory turbulent boundary layer theory presented by Kajiura(1964, 1968), where the vertical component of velocity was neglected, the thickness of the turbulent boundary layer in the present case was estimated as about 3.5 cm Even if the above thickness is larger than the rise of ripple, the vertical velocity component seems not to be neglected owing to the fact that the stated value is comparable to the horizontal one in the vicinity of ripples The authors believe that the Kajiura's theory on the oscillatory boundary layer flow should be modified with the consideration of the above stated fact

Here the turbulence intensity is defined as the root mean square of the turbulence fluctuation In Figure 6

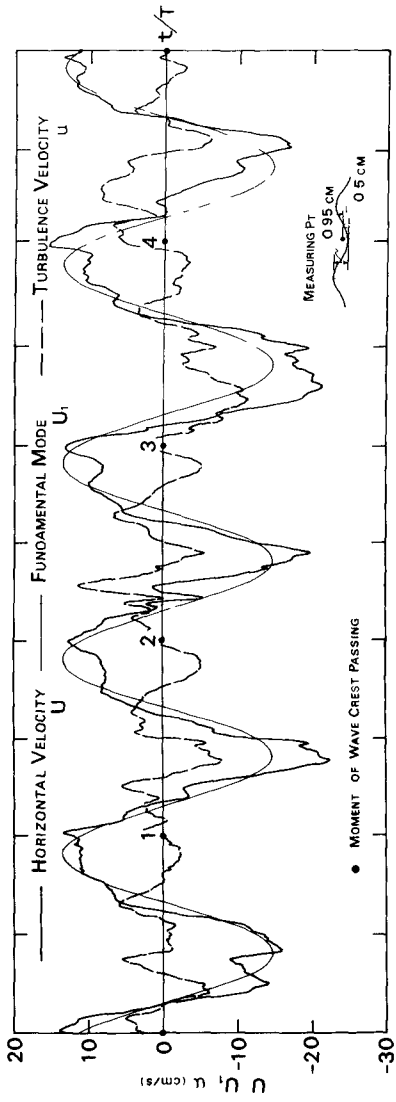

Fig 4 Time history of horizontal velocity component

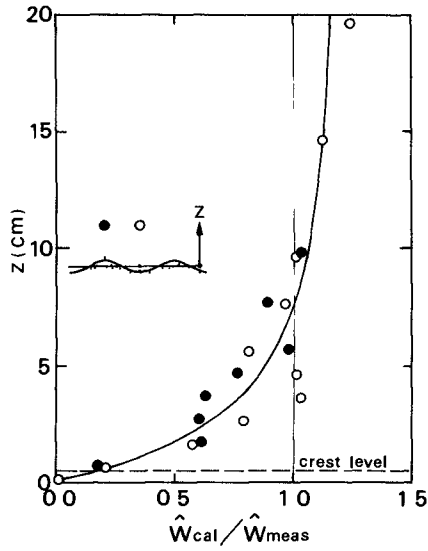

Fig 5 Amplitude ratio of W_{cal} to W_{meas}

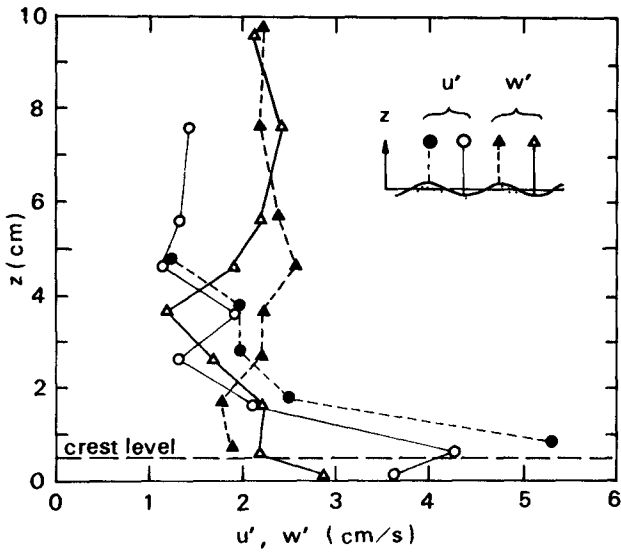

Fig 6 Vertical distributions of turbulence intensities, u' and w' .

are shown the vertical distributions of horizontal and vertical components of turbulence intensity. This diagram indicates that the vertical intensity $w' = \sqrt{w'^2}$ is nearly constant independently of the measuring position, while that the horizontal intensity $u' = \sqrt{u'^2}$ is very high near the bottom boundary. The value of $(u'^2 + w'^2)$, which is related to the total energy of turbulence, is decreasing monotonously with the height above the bottom. These are quite interesting and important facts to investigate the source mechanism of suspended materials from bottom.

Figure 7 is for the normalized spectral energy density $F(n)$ of the horizontal component of turbulence fluctuation u given in Figure 4, where n is a frequency. The range of the major energy content is situated at low frequencies less than 4 cps, and the so-called -7 power law seems to be applicable at higher frequencies larger than about 10 cps. From the latter fact the micro scale of turbulence in time is said to be 0.1 sec. This value seems to be pretty large compared with the result in an air flow, but is in fair agreement with the value obtained by Raichlen (1967), who measured the turbulence intensity of steady flow in an open channel by using a hot-film anemometer. The spectrum computation was made under the condition of 1) the degrees of freedom being about 30 and 2) the lag window being the Hanning procedure.

The different expression of turbulence energy spectrum $n^2 F(n)$, which is related to the rate of turbulence energy dissipation, is shown in Figure 8, from which two peaks are observed at 2~3 cps and 7 cps. Taking consideration of the oscillatory flow pattern in the vicinity of sand ripple and of the wave period of 1.35 sec, the authors believe that the former peak corresponds to the vortex or circulation formed behind a ripple, while that the latter peak corresponds to the turbulence itself induced by the vortex stated above. This kind of approach must be quite valuable to find out 1) the essential reason why such a typical distribution curve as an L shape is appeared in the vertical distribution of suspended sediment concentration, and 2) the critical elevation beyond which a certain sand particle can not exist as a suspended sediment.

RELATIONSHIP BETWEEN SUSPENDED SEDIMENT CONCENTRATION AND TURBULENCE CHARACTERISTICS

The photo-transistor type concentration meter was developed at the Coastal Engineering Laboratory, University of Tokyo (Hom-ma and Horikawa (1963)) and has been improved step by step during the last several years. The circuit diagram of the present instrumentation system is shown in Figure 9. By using this instrument the time history of suspended sediment concentration was recorded under the same condition as the velocity measurement. The above measurements were conducted along the vertical lines above both a crest and a trough

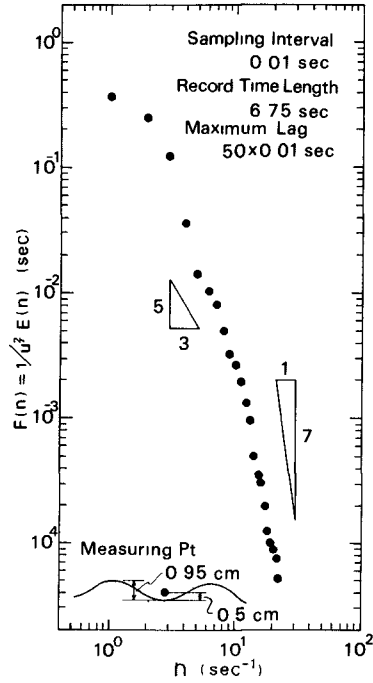

Fig 7 Spectral density distribution of horizontal turbulence component (1), $F(n)$

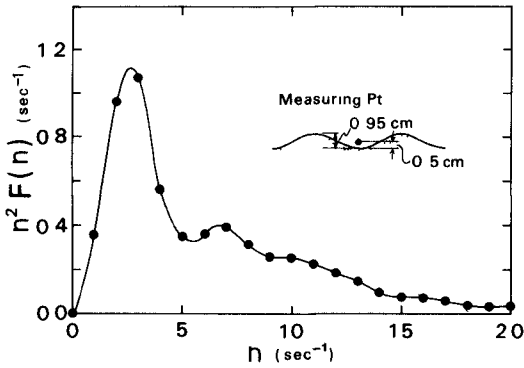

Fig 8 Spectral density distribution of horizontal turbulence component (2), $n^2 F(n)$

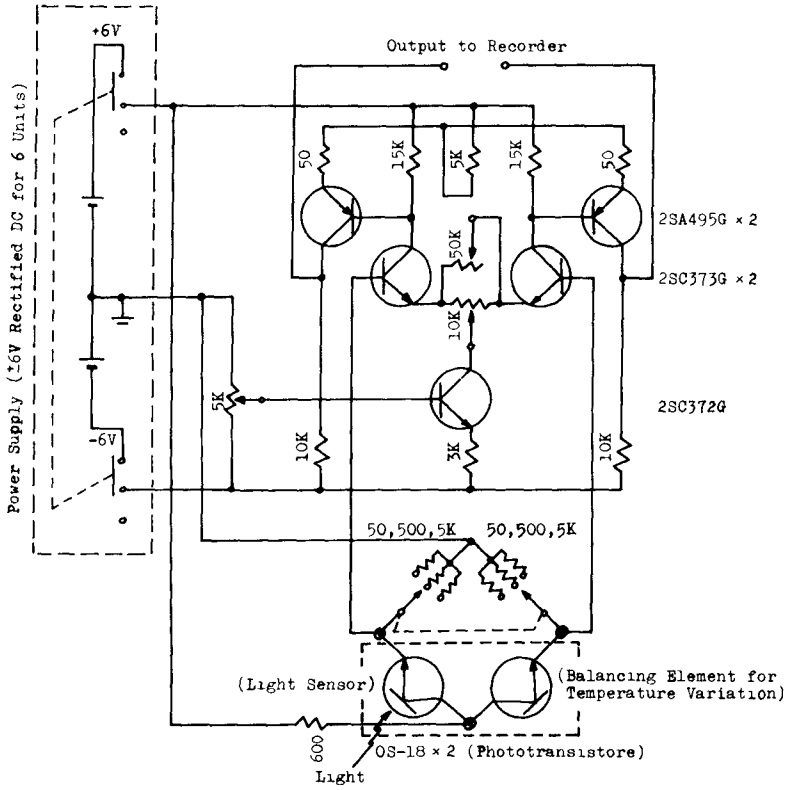

Fig 9 Circuit diagram of photoelectric concentration meter unit

of a certain sand ripple

From the recorded data were determined the time mean concentration \bar{m} and the root mean square value of the fluctuation in sediment concentration $\sqrt{m'^2}$, where m' is its fluctuation determined as the difference between the instantaneous value of sediment concentration m and the time mean concentration \bar{m} . In Figure 10 are shown the vertical distributions of \bar{m} , $\sqrt{m'^2}$ and $\sqrt{m'^2}/\bar{m}$. The last is the value of root mean square of m' normalized by the local mean concentration. From this diagram the following tendencies are observed

- 1) The vertical distribution of mean sediment concentration \bar{m} has an L shape which has commonly been observed in field and in the previous experiments.
- 2) The vertical distribution of these values above the ripple crest are slightly different from, but are basically the same as those above the ripple trough.
- 3) The root mean square $\sqrt{m'^2}$ has its greatest value near the bed and decreases as the elevation increases.
- 4) The distribution of the normalized value $\sqrt{m'^2}/\bar{m}$ is roughly similar to that of the intensity of vertical turbulence component which is shown in Figure 6.

Figure 11 is to show the comparison between the intensity of vertical turbulence component w' and the fall velocity w_0 of sediment particles sampled at corresponding elevations by using a syphon tube. It should be mentioned that the magnitudes of w' and w_0 are comparable.

As stated in INTRODUCTION of this paper Equation(1) is used as the fundamental equation to determine the vertical distribution of mean sediment concentration \bar{m} . By using the analyzed data of sediment concentration and of sediment fall velocity, the value of diffusion coefficient K_z at each elevation can be evaluated on the basis of Equation(1)

On the other hand the following relationship can be taken as an analogue of the eddy viscosity ϵ_m

$$\epsilon_m = -\frac{\overline{uw}}{\partial \bar{U} / \partial z} \sim \frac{\mathcal{L}(\partial \bar{U} / \partial z) \overline{w}}{\partial \bar{U} / \partial z} \sim \mathcal{L} \overline{w} \sim \mathcal{J}_E w'^2 \quad (2)$$

where u and w are the turbulence fluctuation in horizontal and vertical directions respectively, \bar{U} is the mean value of horizontal velocity component, z is taken positive upward, w' is the intensity of vertical turbulence fluctuation, \mathcal{L} is the mixing length, and \mathcal{J}_E is the Eulerian integral time scale related to w . The value of \mathcal{J}_E is calculated by the following equations

$$\left. \begin{aligned} \mathcal{J}_E &= \int_0^{\infty} R_E(\tau) d\tau \\ R_E(\tau) &= \frac{\overline{w(t)w(t+\tau)}}{w'^2} \end{aligned} \right\} \quad (3)$$

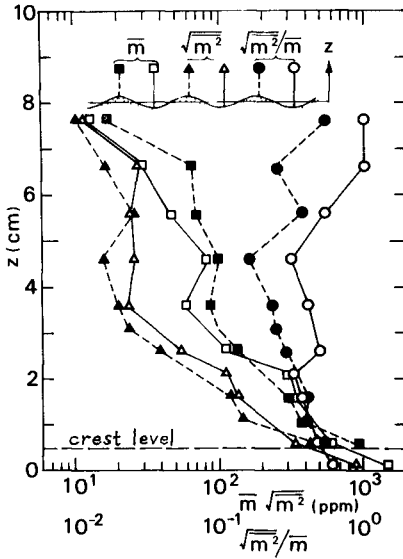

Fig 10 Vertical distributions of mean concentration \bar{m} , concentration fluctuation $\sqrt{\bar{m}^2}$ and $\sqrt{\bar{m}^2}/\bar{m}$

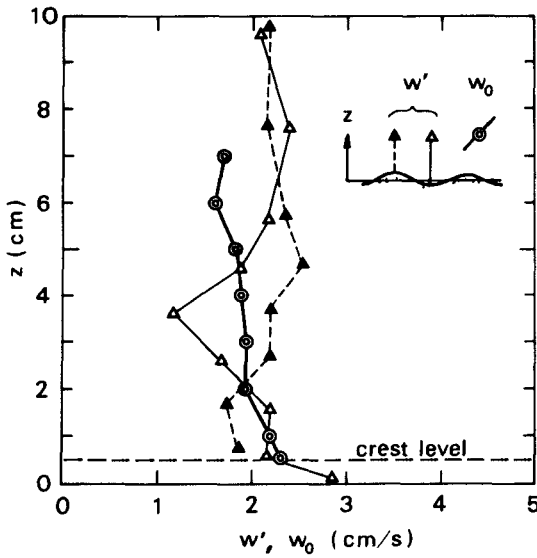

Fig 11 Comparison between vertical turbulence intensity w' and fall velocity w_0

where R_E is a coefficient of Eulerian time correlation

In order to compare the vertical distribution pattern of K_Z with that of $\mathcal{J}_E w'^2$, the values of both factors calculated through the stated methods were plotted in Figure 12. It is quite interesting that the distribution pattern of K_Z is rather similar to that of $\mathcal{J}_E w'^2$. There are still numerous uncertainties remained unsolved, hence it is certainly needed to accomplish further studies related to the following subjects, such as 1) to reevaluate the order of the term $d(\overline{m'w})/dz$ which was neglected in Equation (1), and 2) to find out the precise expression for ϵ_m . The authors have the strong intention to improve the newly developed instrumentation system of ELETT in order to get more accurate data, and also to accumulate much more data with the aim of finding the generalized relationship between the diffusion coefficient K_Z and the eddy viscosity ϵ_m .

CONCLUSIONS

In order to clarify the mechanism of suspension phenomena due to progressive waves, it is of essentially importance to observe and to understand the turbulence fluctuation characteristics under the oscillatory flow condition. On the basis of the above concept the authors developed a new anemometer named as ELETT (electrolytic turbulence transducer) and obtained a certain amount of measuring data. This is at any rate the preliminary approach to attack the turbulence characteristics induced by oscillatory flows, hence there are many problems to be solved in future. For example to establish the linearization of instrument output, to make clear the frequency characteristics of this instrument, and to find out more rational way of separating the turbulence fluctuation from the actual velocity record are the problems with which the authors have confronted at present.

The authors believe that the relationship among the turbulence intensity, the bottom roughness and the wave characteristics might be clarified in future owing to the further accumulation of laboratory data. The vertical distribution of turbulence intensity may be attacked theoretically on the basis of the turbulence energy equation. The authors have an intention to proceed the present treatment to the following directions in order to understand more clearly the relationship between the suspended sediment concentration and the turbulence characteristics. These are

- 1) to reevaluate the effect of convective term on a suspended sediment concentration, and to reconsider the expression of eddy viscosity; these are to find out the rational expression for the diffusion coefficient and for the vertical distribution of suspended sediment concentration
- 2) to make clear the characteristic concentration at a certain elevation, which is used as a measure to determine the vertical distribution of suspended sediment concentration, the characteristic concentration stated above is

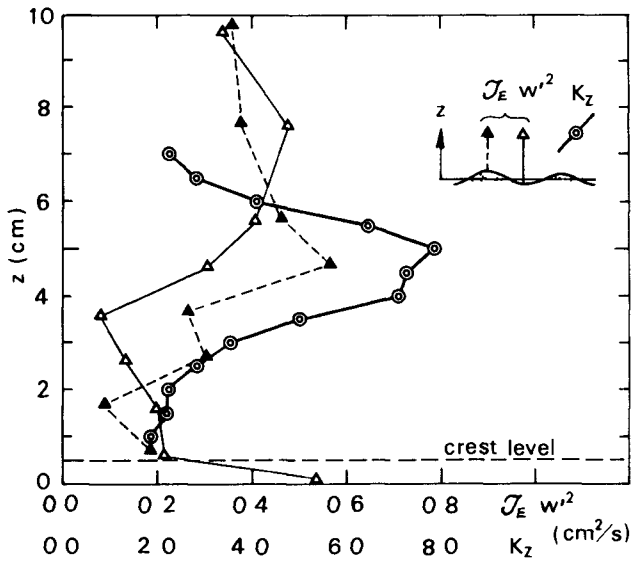

Fig 12 Comparison between analogue of eddy viscosity $\mathcal{T}_E w'^2$ and eddy diffusivity K_z

expected to have a close relationship with the Reynolds stress in the vicinity of bottom. The transducer reported here seems to be applicable to measure the Reynolds stress, therefore the pick-up and data processing system which are suitable for the present purpose should be developed in future.

ACKNOWLEDGEMENT

The work reported herein is a part of investigations carried out at the Coastal Engineering Laboratory, University of Tokyo, under the support of the Scientific Research Fund of the Ministry of Education in Japan.

REFERENCES

- Binder, G (1967) Potential fluctuations generated by turbulence on a small wire, Proc. 12th Congress, I A H R
- Hom-ma, M. and K. Horikawa (1962) Suspended sediment due to wave action, Proc 8th Conf on Coastal Engng
- Hom-ma, M and K Horikawa (1963) A laboratory study on suspended sediment due to wave action, Proc. 10th Congress, I A H R
- Hom-ma, M, K Horikawa and R Kajima (1965) A study on suspended sediment due to wave action, Coastal Engng. in Japan, Vol. 8
- Horikawa, K and A Watanabe (1967) A study on sand movement due to wave action, Coastal Engng. in Japan, Vol 10
- Horikawa, K. and A Watanabe (1968) Laboratory study on oscillatory boundary layer flow, Proc. 11th Conf on Coastal Engng
- Iwagaki, Y. and T Sakai (1969) Experiments on water particle velocity of finite amplitude waves, Proc 16th Conf. on Coastal Engng in Japan (in Japanese)
- Jonsson, I G (1963) Measurement in the turbulent wave boundary layer, Proc 10th Congress, I A H R
- Kajiura, K (1964) On the bottom friction in an oscillatory currents, Bull. Earthq Res Inst., Univ of Tokyo, Vol 42.
- Kajiura, K. (1968) A model of the bottom boundary layer in water waves, Bull. Earthq Res. Inst., Univ of Tokyo, Vol 46.
- Raichlen, F. (1967) Some turbulence measurements in water, Jour. Engng Mech Div, Proc. ASCE, Vol. 93, No EM 2.