

Article

Turning Servile Opportunities to Gold: A Strategic Analysis of the Corporate Opportunities Doctrine

Eric Talley[†]

CONTENTS

I. INTRODUCTION	279
II. LEGAL DOCTRINE	286
A. <i>Characterization Tests (Node A)</i>	289
1. <i>The “Line-of-Business” Test</i>	289
2. <i>The “Interest-or-Expectancy” Test</i>	292
3. <i>The “Fairness” Test</i>	293
4. <i>Alternative Tests, Composites, and Hybrids</i>	295
B. <i>Disclosure and Rejection (Nodes B and C)</i>	296
C. <i>Remedy for Breach (Nodes X₁ and X₂)</i>	298

[†] Associate Professor, University of Southern California Law School. I owe thanks to Scott Altman, Jennifer Arlen, Ian Ayres, Steve Bainbridge, Howard Chang, Pat Chew, Bob Cooter, Dick Craswell, Jill Fisch, Jesse Fried, Ron Garet, Ariela Gross, Henry Hansmann, Reinier Kraakman, Bill Klein, Gillian Lester, Tracy Lewis, John Matsusaka, Bentley MacLeod, Brent McIntosh, Larry Mitchell, Mitch Polinsky, Mark Ramseyer, Richard Revesz, Steve Salop, Warren Schwartz, Mike Shapiro, Howard Shelanski, Matt Spitzer, Christopher Stone, Jeff Strnad, Mark Weinstein, and seminar participants at the USC Law and Business Schools, Georgetown University Law Center, California (Boalt Hall) School of Law, Stanford Law School, and the 1998 American Law and Economics Association conference for helpful comments and discussions. Many thanks also to Jeff Backhus, Suzy Bramzon, and Janet Hurdle for excellent research assistance. Support from the James H. Zumberge Faculty Research and Innovation Fund is gratefully acknowledged. Apologies to William Wordsworth, from whose *Memorials of a Tour on the Continent, 1820 XXXVII: Desultory Stanzas* the first phrase of the title is borrowed. All errors are mine.

D.	<i>A Normative Quandary</i>	299
E.	<i>Two Cases and a Conjecture</i>	303
1.	Energy Resources Corp. v. Porter	303
2.	Broz v. Cellular Information Systems.....	305
3.	<i>Distinguishing the Cases:</i> <i>An Information-Based Conjecture</i>	306
III.	AN OPTIMAL-CONTRACTING MODEL OF CORPORATE OPPORTUNITIES	310
A.	<i>Framework</i>	311
B.	<i>Contracting</i>	316
C.	<i>Complete Information</i>	322
D.	<i>Private Information</i>	326
1.	<i>No Overlap</i>	329
2.	<i>Partial Overlap</i>	332
3.	<i>Complete Overlap</i>	336
IV.	DOCTRINAL IMPLICATIONS	336
V.	EXTENDING THE MODEL.....	344
A.	<i>Endogenous Specialties</i>	345
B.	<i>Alternative Information Structures</i>	348
C.	<i>The Role of Commitment</i>	350
VI.	CONCLUSION.....	351
	APPENDIX.....	353

I. INTRODUCTION

Perhaps no single motif permeates corporate law and governance literature like the problem of agency costs.¹ Though modest in concept, the canonical principal-agent framework yields fundamental insights into virtually every economic relationship involving the firm. These insights, in turn, not only animate prevailing positive accounts of the modern corporation, but they also provide a normative basis for regulating the oft-lamented gulf between ownership and control.

Despite their pervasiveness, problems of agency costs are rarely more vexing than when an agent is also a potential competitor. A notable example of such a scenario occurs when a corporate manager acquires information about a new business prospect—one which she may be tempted to appropriate for her own personal benefit. In such instances the fiduciary's and shareholders' respective interests are not merely askew, but rather are in profound opposition to one another. Concern over such outright conflict provides the foundation for the "corporate opportunities doctrine" (COD), which is the law's attempt to regulate circumstances in which a corporate officer or director may usurp new business prospects for her own account without first offering them to the firm. The doctrine—a subspecies of the fiduciary duty of loyalty—has been a mainstay in the corporations law of virtually every state for well over a century.

In most jurisdictions, COD litigation follows (at least superficially) some variant of the following legal "algorithm": Once a new project is deemed to be a corporate opportunity, a fiduciary may not appropriate it without first offering it to the firm and disclosing her conflict of interest. Pursuit of the project in the absence of full disclosure or without proper rejection from the corporation constitutes a breach of fiduciary duty, carrying rather formidable repercussions: The firm may obtain injunctive relief (if feasible), disgorgement of the fiduciary's gains, and even punitive damages.

Regrettably, this doctrinal algorithm has proven as unwieldy in application as it is concise in recitation. Courts have struggled mightily over the years to formulate precise definitions of "corporate opportunity," "full disclosure," and "proper rejection." Repeated endeavors by litigants, judges, and legal scholars to clarify the doctrine have generated a panoply of tests, variations, and hybrids. But the end product of this collective effort appears—by virtually all accounts—more tautologous than diagnostic, replete with exceptions and indecipherable distinctions that provide little guidance either to theorists or to practitioners.²

1. Most conventional accounts define "agency costs" to be the aggregation of costs due to monitoring, signaling, and bonding that are designed to make an agent's incentives compatible with the principal's, along with any direct residual costs from misaligned incentives that remain after implementation of such measures. *See, e.g.,* Michael Jensen & William Meckling, *The Theory of the Firm: Managerial Behavior, Agency Costs, and Ownership Structure*, 3 J. FIN. ECON. 305, 308 (1976).

2. *See, e.g.,* *Northeast Harbor Golf Club, Inc. v. Harris*, 661 A.2d 1146, 1148-49 (Me. 1995) ("[T]here has been much confusion about the specific extent of [the fiduciary] duty when . . . it is contended that a fiduciary takes for herself a corporate opportunity."); *Miller v. Miller*, 222 N.W.2d 71,

In the pages that follow, I attempt to chart a course out of this doctrinal quagmire by offering a normative account of the COD that emerges from the economic theory of contract. I argue that both the reach and the consequences of an efficient legal rule depend crucially on the *information structure* that imbues the agency relationship between fiduciaries and corporate shareholders. In particular, I demonstrate that the contours of an “optimal” doctrine turn crucially on the extent to which corporate fiduciaries possess private, unverifiable knowledge about the relevant characteristics of new projects. From a practical standpoint, this thesis suggests that more careful judicial attention to information structure may lead to a significantly more tractable COD.

My argument proceeds from a simple observation. The COD is, fundamentally, little more than a default mechanism for allocating property rights between a corporation and those who manage it. Indeed, from a strategic perspective, the rules governing liability and remedy implicitly preordain the two defining economic features of any property rights allocation: first, who among the parties possesses ultimate control over some disputed activity; and second, how the parties will divide the returns that therefrom. Consistent with this observation, fashioning a rule that replicates (at least functionally) the allocation that the parties themselves would have

79 (Minn. 1974) (“We have searched the case law and commentary in vain for an all-inclusive or ‘critical’ test or standard by which a wrongful appropriation can be determined and are persuaded that the doctrine is not capable of precise definition.”); ROBERT CHARLES CLARK, *CORPORATE LAW* 244-45 (1986) (“The traditional tests are extremely ambiguous and uncertain in their application.”); JAMES D. COX ET AL., *CORPORATIONS* 236-37 (1997) (describing the doctrine as unpredictable and noting that “a good deal of uncertainty exists as to what constitutes the usurpation of a corporate opportunity”); Victor Brudney & Robert Charles Clark, *A New Look at Corporate Opportunities*, 94 HARV. L. REV. 998, 998 (1981) (“Not only are the common formulations vague, but the courts have articulated no theory that could serve as a blueprint for constructing meaningful rules.”); Pat K. Chew, *Competing Interests in the Corporate Opportunity Doctrine*, 67 N.C. L. REV. 435, 465-66 (1989) (noting that the field is “in transition,” and that “courts cite traditional tests in an almost perfunctory way, but the test on which they actually rely is sometimes unrecognizable as the traditional tests cited”); Robert Cooter & Bradley J. Freedman, *The Fiduciary Relationship: Its Economic Character and Legal Consequences*, 66 N.Y.U. L. REV. 1045, 1045 (1991) (“[T]he precise nature of the fiduciary relationship remains a source of confusion and dispute.”); Harvey Gelb, *The Corporate Opportunity Doctrine—Recent Cases and the Elusive Goal of Clarity*, 31 U. RICH. L. REV. 371, 372 (1997) (“[T]he yearning of courts for clarity in the corporate opportunity area is evident and understandable.”); Klaus J. Hopt, *Self-Dealing and Use of Corporate Opportunity and Information: Regulating Directors’ Conflicts of Interest*, in *CORPORATE GOVERNANCE AND DIRECTORS’ LIABILITIES* 285, 299 (Klaus J. Hopt & Gunther Teubner eds., 1985) (describing the specific tests developed by American courts as being “far from . . . crystal clear”); Michael Begert, Comment, *The Corporate Opportunity Doctrine and Outside Business Interests*, 56 U. CHI. L. REV. 827, 827-28 (1989) (arguing that “[u]ncertain[ies have] produced a confusion of approaches to corporate opportunity” and that “[a]ttempts to organize these decisions into a coherent set of rules are frustrated by subtle distinctions between precedents”); David J. Brown, Note, *When Opportunity Knocks: An Analysis of the Brudney & Clark and ALI Principles of Corporate Governance Proposals for Deciding Corporate Opportunity Claims*, 11 J. CORP. L. 255, 255 (1986) (“Courts have had considerable difficulty in determining the circumstances under which a fiduciary should be precluded from taking a business opportunity for his own benefit.”); Note, *Corporate Opportunity in the Close Corporation—A Different Result?*, 56 GEO. L.J. 381, 382 (1967) (“[C]onclusory tests have proved to be indistinguishable and meaningless.”).

bargained for ex ante had they anticipated such contingencies should be an important goal of the courts.³

The pursuit of such a goal, however, implicates two competing normative concerns. On the one hand, since corporations are generally perceived to enjoy a comparative advantage over their fiduciaries when it comes to production, there is a plausible justification for encouraging managers to “channel” most new projects into the firm. On the other hand, absolute deterrence of fiduciaries may sometimes be socially wasteful, particularly for projects requiring talents, flexibility, or resources that the agent possesses but the corporate entity lacks.⁴

Under ideal circumstances, in which transactions are frictionless, monitoring is costless, and all relevant information is verifiable, this balancing process is fairly unproblematic: A court should simply allocate the property right to whomever is the lowest-cost producer. Such an allocation would maximize expected joint wealth of the interested parties, which they could divide amongst themselves through appropriate side payments. Furthermore, even if courts were to fail in implementing such a rule, the corporation and the fiduciary could still effect an efficient allocation on their own, either at the ex ante stage (through express contractual terms) or at some later stage (through Coasean renegotiation).

Circumstances, however, are rarely ideal. The costs of contemplating and drafting express terms to govern every possible future contingency are sometimes high, if not prohibitive, and inevitable contractual gaps or linguistic ambiguities will sometimes necessitate clarification by courts ex post. Compounding this dilemma is the fact that fiduciaries are frequently in a unique position to acquire information about the existence, nature, and characteristics of new opportunities, much of which is extremely costly (or impossible) for shareholders to observe or for courts to verify.⁵ Indeed, the

3. Among corporations scholars, there appears to be considerable agreement that this normative role of “gap-filling” is fundamental. *See, e.g.,* LARRY E. RIBSTEIN & PETER V. LETSOU, *BUSINESS ASSOCIATIONS* 544 (3d ed. 1996) (“The applicable [legal] rule arguably should minimize the need for customized contracts by matching the bargain firms and employees usually would make.”); Brudney & Clark, *supra* note 2, at 999 (noting that the doctrine “makes it unnecessary for a principal . . . to provide by contract an array of prohibitions against the agent diverting to himself the principal’s assets”); Cooter & Freedman, *supra* note 2, at 1067 (likening the optimal doctrine to the optimal contract).

To be sure, one might posit alternative normative accounts of corporate law in general and fiduciary duties in particular. I elaborate further on two alternative normative accounts in Section II.D. Ultimately, however, I find that the contractarian account is the most persuasive in the corporate opportunities context.

4. *See, e.g.,* FRANK H. EASTERBROOK & DANIEL R. FISCHER, *THE ECONOMIC STRUCTURE OF CORPORATE LAW* 140 (1991) (arguing that absolute bans on appropriations will “deter the undertaking of some value-increasing ventures or cause them to be undertaken inefficiently”).

5. A number of legal commentators and courts have noted that the most problematic aspect of the agent’s private information is not limited to a project’s mere existence, but rather extends as well to its precise characteristics. *See, e.g.,* *Regal-Beloit Corp. v. Drecoll*, 955 F. Supp. 849, 861 n.5 (N.D. Ill. 1996) (holding that disclosure requirements pertain “not only to the existence of the opportunity, but also to any facts that may be pertinent to the corporation’s ability and/or willingness to seize upon that opportunity”); 3 WILLIAM MEADE FLETCHER, *FLETCHER CYCLOPEDIA OF THE LAW OF PRIVATE CORPORATIONS*, § 861.1, at 285 (perm. ed. rev. vol. 1994) (“[M]ere disclosure of the transaction, without

chief targets of the COD (directors and officers) share a common role as organizational “gatekeepers,” evaluating new business prospects and recommending which ones the corporation should pursue versus those it should eschew. The shareholders, out of either limited motivation or lack of expertise, typically are not privy to such detailed knowledge. This informational disjuncture, in concert with the well-known collective action problems that typify diffuse ownership structures, can thwart attempts at direct negotiation, thereby leaving much of the property rights allocation to be decided in litigation.

I will argue that within such a context, private information substantially distorts the characteristics of an efficient COD. In particular, when agents possess proprietary knowledge about the relevant characteristics of new projects,⁶ the optimal legal rule will tend—relative to its complete-information counterpart—to be over-inclusive (detering the appropriation of certain projects in which the corporation is wholly uninterested) and may sometimes even be under-inclusive (failing to deter appropriation of projects for which the corporation is the most efficient producer). The intuition behind this thesis stems from an uneasy tension between maximizing wealth and providing fiduciaries with sufficient incentives to disclose information. When the relevant characteristics of new projects are publicly known, it is unnecessary to address the latter concerns thereby enabling efficiency-minded courts to concentrate solely on wealth maximization. When an agent possesses private information, however, she may have an incentive to misrepresent her knowledge for personal gain. In such situations, an optimal legal rule should attempt to counteract these (generally counterproductive) distortions. But creating such counter-incentives substantially limits the allocational choices that the parties (or a court) have available. Consequently, an optimal legal rule in a private-information environment may consciously permit some inefficiencies in order to obviate even greater efficiency losses.

The implications of this central insight turn out to be significant for doctrinal clarification and reform. Most immediately, it suggests that when important characteristics about a disputed project are difficult (or prohibitively costly) to verify *ex post*, it may be prudent for a court to disregard the parties’

revealing the surrounding circumstances, is not sufficient, and failure to make complete disclosure constitutes constructive fraud, thereby tolling the statute of limitations.”).

The law-and-economics literature on corporate opportunities still appears to be relatively sparse. Robert Cooter and Bradley Freedman, however, briefly examine the corporate opportunities doctrine when the agent’s private information is limited solely to knowledge about the existence of a new project. They find that beyond the inclusion of a damages multiplier (which has been called the “rule of the reciprocal”), the structure of an optimal contract varies little from its perfect-information counterpart. Cooter & Freedman, *supra* note 2, at 1061-62. I explicitly consider this permutation in Part IV.

6. To be sure, proprietary knowledge about new projects is not the only type of informational advantage a fiduciary might enjoy. She might, for example, have private information about her own abilities and/or actions. Nonetheless, this Article analyzes project-oriented information asymmetries as a vehicle for demonstrating its larger thesis because such asymmetries appear to be prevalent in the case law. *See, e.g., infra* note 37 (noting the problems that courts have had with verifiability in the so-called “incapacity defense” cases). I briefly address other types of information structure *infra* text accompanying notes 224-225.

competing claims about the project altogether, concentrating instead on the characteristics of the *litigants themselves*, such as the commonality of their respective areas of expertise. The analysis also suggests that in such situations, the optimal doctrine typically has a broad reach, imposing liability on fiduciaries for appropriating virtually *any* project. At the same time, however, the optimal damages associated with liability are somewhat “untailored” in nature (much like liquidated damages) and need not be so large as to deter the fiduciary from appropriating high-profitability projects.⁷

Finally, my arguments lend support to a “meta-thesis” that recurs here as it does in many other applications of information economics to law: In order to fashion a legal rule that is optimal from an *ex ante* perspective, one must be willing to commit to that rule even if its application appears wasteful or inefficient *ex post*. Unless courts are willing and able to so commit, not only would it be impossible to realize the first-best outcome, but the anticipation of subsequent commitment problems could create perverse incentive effects that would render the second-best outcome unattainable as well. Similarly, if the *parties themselves* find it difficult to refrain from renegotiating allocations *ex post*, the identical incentive problem may result. One way the law can ameliorate this latter commitment problem is to make it costly or impossible to contract around the optimal default rule subsequent to incorporation.⁸

Before proceeding, a few caveats are in order. First, the general claim that private information plays a central role in the corporate opportunities context is hardly a novel one. Other legal scholars have previously noted the relevance of information asymmetries, and some have advocated (albeit informally) the development of a COD that accounts for such asymmetries.⁹ While my approach is very much in that same spirit, it attempts to go one step further, positing and analyzing a formal economic model of contracting over intra-firm property rights.¹⁰ This formal approach, in turn, reveals intuitions

7. The results also provide interesting insights into the justifications for a number of other doctrinal innovations, such as the “incapacity defense,” the “source rule,” the doctrine of “implied rejection,” and common distinctions between close versus public corporations and outside versus inside directors. See *infra* Part IV.

8. Economists and game theorists have long recognized this potential problem in contractual environments. See, e.g., Mathias Dewatripont, *Renegotiation and Information Revelation over Time: The Case of Optimal Labor Contracts*, 104 Q. J. ECON. 589 (1989) (attending to the *ex post* renegotiation problem in canonical principal-agent settings); Finn E. Kydland & Edward C. Prescott, *Rules Rather than Discretion: The Inconsistency of Optimal Plans*, 85 J. POL. ECON. 473, 487 (1977) (noting the problem in the context of a monetary policy “contract” between the government and citizens). For a comprehensive summary of this literature, along with an argument that commitment problems provide a normative basis for prohibiting contractual modification, see Christine Jolls, *Contracts as Bilateral Commitments: A New Perspective on Contract Modification*, 26 J. LEGAL STUD. 203 (1997).

9. See Chew, *supra* note 2, at 483; Cooter & Freedman, *supra* note 2, at 1054-55; Richard A. Epstein, *Contract and Trust in Corporate Law: The Case of Corporate Opportunity*, 21 DEL. J. CORP. LAW 5, 14-15 (1996).

10. See generally Epstein, *supra* note 9, at 24 (“[I]t is no simple matter to figure out exactly what the rights and duties are when engaged in that formidable task of hypothetical reconstruction of contracting alternatives from the *ex ante* perspective.”). Cooter and Friedman, *supra* note 2, at 1052-53, make a brief inquiry into this question, focusing on a specific manifestation of private information: a fiduciary’s binary choice of whether to appropriate an opportunity. The analysis I present below attempts

that contrast significantly with earlier proposals from other legal scholars. For example, Victor Brudney and Robert Clark's now classic analysis of the COD uses a type of "information cost" argument to advocate a separate doctrine for widely-held firms.¹¹ According to Brudney and Clark, fiduciaries of public corporations are harder to monitor than are their counterparts in close corporations and should therefore be subject to an immutable and "categorical" rule forbidding the appropriation of any new project. My analysis, while providing partial support for the public-close distinction, ultimately reveals categorical prohibition to be somewhat extreme. In particular, even if ownership structure is a good proxy for information asymmetry, it does not follow that categorical prohibition is the best judicial response. On the contrary, as I will demonstrate, information asymmetries actually provide a rationale for *instituting* incentive schemes, which by nature may consciously permit the fiduciary to divert at least some projects for her own account.¹²

Second, since my aim is to argue that information structure "matters," it is important to be clear about when it matters most. As my analysis demonstrates, the effects of asymmetric information are particularly stark *when the content of the fiduciary's private knowledge is difficult or costly to verify in ex post litigation*. Indeed, if a court could easily verify the fiduciary's information, the parties simply could litigate each new business opportunity, employing the court to supply the terms of a complete-information contract. While perhaps modest in some cases, verification costs appear to play a

a more general model in which the fiduciary possesses detailed information about the characteristics of the opportunity.

Stuart Turnbull has advocated a "market-based" test to determine corporate opportunities. Specifically, he argues that a usurped opportunity should be deemed a corporate one if share prices fall after an appropriation. *See* Stuart M. Turnbull, *The Doctrine of Corporate Opportunity: An Economic Analysis*, 13 CAN.-U.S. L.J. 185, 190-91 (1988). While intriguing, this proposal has a number of conceptual difficulties. In particular, market-based remedies become complicated when share prices reflect expectations about prospective legal recovery. A strong form of this criticism may lead one to deduce exactly the opposite of Turnbull's prediction, i.e., that a fiduciary's appropriation of a project might even *increase* share prices if the market perceives a high likelihood of obtaining a disgorgement remedy.

11. *See* Brudney & Clark, *supra* note 2, at 1060-61. Their arguments are largely reproduced in Clark's treatise on corporate law, *see* CLARK, *supra* note 2, and (perhaps consequently) have enjoyed a fair amount of sway among judges and other legal commentators.

12. Brudney and Clark essentially assume away this possibility, a puzzling response given the contractarian gap-filling approach they claim to employ. Brudney & Clark, *supra* note 2, at 999 ("The agent's overt compensation is presumably sufficient to induce the desired performance, so there is no need to permit an indeterminate amount of additional, covert compensation derived from the agent's unilateral decision to divert the principal's assets.") (contrary citation omitted).

On a related point, Brudney and Clark note that in close corporations, it is relatively simple for a fiduciary to obtain "consent" to pursue an opportunity through bargaining with the relatively small number of other participants. One wonders, however, why this observation leads inexorably to their conclusion that a more flexible rule should apply to closely held firms. Indeed, if the shareholders of close corporations faced low renegotiation costs, the Coase Theorem suggests that the background rule would not be particularly critical. By implication, in public firms it would seem even more critical for an efficiency-minded court to devise a legal rule that "gets it right the first time" by mimicking the optimal allocation of property rights between the firm and fiduciary.

nontrivial role in others. Indeed, this heterogeneity of cases makes attention to information structure both interesting and critical.

Third, it is important to note that the COD is but one of a handful of related doctrines that regulate the misappropriation of corporate assets. Other affiliated doctrines proscribe the intrafirm allocation of trade secrets and tangible property and govern the duty not to compete with the corporation.¹³ While my focus here is limited to the corporate opportunities context, one could conceivably apply a similar analytical approach to these other cases as well. I shall comment briefly on such applications, but I leave their execution for future research.

Finally, this Article adopts a normative account of corporate law with an unambiguously "contractarian" flavor, divining the features of an optimal doctrine from those of an express contract that would plausibly emerge from *ex ante* bargaining.¹⁴ While such an approach is now quite standard within the law and economics literature, a number of competing normative accounts exist.¹⁵ My analysis does not venture far into these alternative accounts. Nonetheless, the distinct advantage of the model I present is that it may lend itself to a noncontractarian interpretation *as well as* a contractarian one.

The remainder of this Article proceeds as follows. Part II explores the current COD in greater detail, describing the prevailing judicial tests and the confusion that presently engulfs the doctrine. This part culminates with a comparison of two well-known corporate opportunities cases and an information-based argument to distinguish their respective facts. Part III uses this doctrinal review to construct a game-theoretic model of contracting over the allocation of new business projects. I use this model to illustrate how the optimal contract terms vary (often dramatically) with the introduction of private information, thereby illustrating my principal thesis. Part IV discusses the doctrinal implications of the analysis, advocating the development of an alternative doctrine to govern private-information settings. Part V considers a number of generalizations of the analysis, including an extension of the

13. In fact, similar concerns pervade doctrines that transcend the basic corporate framework entirely. In community property law, for instance, courts often must determine whether new business prospects are a part of the marital estate or appropriable by the recipient. *See, e.g., Gay v. Lucero (In re Lucero)*, 118 Cal. App. 3d 836 (1981) (holding that a husband's decision to use his separate funds to reinstate a pension was a violation of his duty of good faith, since the right to reinstate the pension was itself a right earned during the marriage and therefore a community entitlement); *Somps v. Somps*, 250 Cal. App. 2d 328 (1967) (allowing a husband to use separate funds to purchase real estate, as he had learned about the opportunity through his business, which was only partly a community asset).

14. I should note that while this definition of "contractarianism" is the predominant one used in corporations and contracts literature, the term may have a slightly different meaning elsewhere. For instance, a "social contractarian" analysis might inquire how the parties would bargain with one another under fair conditions from behind the so-called veil of ignorance, in which they have yet to learn their identities. *See JOHN RAWLS, A THEORY OF JUSTICE 17-21 (1971)*. My analysis does not adopt this latter definition, however, because of the complex dynamic interaction between legal rules and *actual* bargaining. *See infra* text accompanying notes 82-91.

15. *See, e.g., Lawrence E. Mitchell, Fairness and Trust in Corporate Law*, 43 DUKE L.J. 425, 429 (1993) (proposing that in certain cases the fiduciary's interest should be removed from judicial consideration); Lawrence E. Mitchell, *Trust. Contract. Process.*, in PROGRESSIVE CORPORATE LAW 185 (Lawrence E. Mitchell ed., 1995).

model. Part VI presents concluding remarks. For readers who wish to examine a more formal presentation of my principal argument, a technical appendix follows the body of the Article.

II. LEGAL DOCTRINE

This Part offers a brief descriptive tour through the contours of the current COD. Such an exercise might appear curious at first, particularly since my ultimate enterprise is significantly more normative than it is positive.¹⁶ Nevertheless, such a descriptive inquiry is valuable for at least two reasons. First, since my hope is to characterize an optimal doctrine using an economic model of contracting, it is important that the model capture salient practical issues that courts often find contentious and difficult to adjudicate. Second, prevailing doctrine represents a benchmark from which to tease out the implications that the model's results might have for legal reform.

As noted in the Introduction, the COD is one of several doctrines that regulate the appropriation of corporate property by an agent of the firm.¹⁷ Although these respective doctrines overlap considerably, what immediately distinguishes the COD in practice is its relatively limited scope. Indeed, the COD prescribes duties that extend *exclusively* (or nearly so) to corporate directors and officers, but not to other agents, employees, or stakeholders in the firm.¹⁸ This observation is significant because it suggests that the underlying motivation behind the COD has relatively little to do with day-to-day incentive problems on the proverbial "factory floor." On the contrary, officers and directors play little or no direct role in routine production operations. Rather, what these corporate fiduciaries appear jointly to share from an agency-cost perspective is a macro-organizational role as "gatekeepers." Unlike rank-and-file employees or mid-level management, directors and officers play a predominant role in evaluating the relative merits of prospective new projects, recommending which the firm should pursue and which it should eschew.¹⁹ It therefore seems plausible (if not likely) that one

16. It is important for the reader to be clear on the normative nature of my approach. While a large portion of "law and economics" is devoted to positive analysis—i.e., providing a theory for explaining why courts decide cases the way that they do—the COD does not (in my estimation) lend itself to such an approach. Indeed, it is the very judicial confusion that currently surrounds the doctrine that motivates the instant analysis. *See supra* note 2 (documenting this confusion).

17. *See supra* text accompanying note 13.

18. *See RIBSTEIN & LETSOU, supra* note 3, at 546-47. It should be noted that on rare occasions, the COD has been applied to other relationships of trust and confidence between an agent and the corporation, such as dominant shareholders. *See A. Teixeira & Co. v. Teixeira*, 699 A.2d 1383, 1387 (R.I. 1997) (holding that the COD applies to a shareholder not affiliated with management if that shareholder actively participates in management decisions). But even in these instances, the doctrine is invoked because a classic agency problem exists among the shareholders, in which the dominant shareholder exercises control over the firm's activities despite incomplete ownership.

19. This information-processing role is widely recognized in the corporations literature. The following excerpt from Robert Clark is typical:

[A] very large portion of any manager's job consists of gathering, evaluating, relating, and dispensing pieces of *information*. He or she is an information processor par excellence. The term *information* is used here in a broad sense: it includes not only bits of

of the primary purposes of the COD is to address incentive problems that are unique to this gatekeeping function.

Confined to this narrow scope of application, most modern corporate opportunities cases follow a simple (though perhaps deceptively so) analytical algorithm, represented below by Figure 1. The figure presupposes that a new business prospect has recently been presented to a corporate fiduciary, and it traces the parties' subsequent actions along with the legal consequences thereof. The first relevant legal inquiry occurs at node *A*, where a court must determine whether the project in question constitutes a "corporate opportunity." If not, the legal inquiry ends: Absent express language to the contrary in the corporate charter or employment contract,²⁰ the fiduciary may

factual data, judgments, opinions, and predictions, but also requests, advice, and commands within a firm, and bids and offers among those who potentially might make a deal of some sort. Included within the manager's information processing tasks is the activity of making business *decisions*

CLARK, *supra* note 2, at 802-03. Though one's initial inclination is to ascribe these gatekeeping duties primarily to officers and inside directors, there is mounting evidence that outside directors are increasingly playing a similar role. *See, e.g.*, Hobson Brown, Jr., *What Do Institutional Investors Really Want?*, CORP. BOARD, May 1996, at 5; Robert H. Campbell, *Directors: 'The Brokers of Balance,'* DIRECTORS & BOARDS, June 1996, at 45; Robert F. Felton et al., *Building a Stronger Board*, MCKINSEY Q., Mar. 22, 1995, at 162; Keith J. Loudon, *A Position Description for the Board*, DIRECTORS & BOARDS, Mar. 22, 1993, at 23.

20. The legal power to supplant existing doctrine with express contractual terms is the hallmark of a default rule. Some legal scholars have mentioned in passing that the COD may be a type of "one-way" default rule, permitting parties to enhance the fiduciary's minimal duties, but not to weaken them. *See* Ian Ayres & Robert Gertner, *Strategic Contractual Inefficiency and the Optimal Choice of Legal Rules*, 101 YALE L.J. 729, 743 (1992). Indeed, if a corporate charter or employment contract contained a term purporting to soften the COD by limiting the fiduciary's damages for breach, such a term may well be deemed unenforceable under state law. Delaware's "exoneration statute," for instance, permits a certificate of incorporation to limit or eliminate a director's personal liability for monetary damages stemming from a breach of the fiduciary duty of *care*, but it specifically excepts all duty-of-loyalty violations (including the taking of corporate opportunities). *See* DEL. CODE ANN. tit. viii, § 102(b)(7) (1996). A majority of other states have similar limitations, including Alaska, ALASKA STAT. § 10.06.210(1)(N)(i) (Michie 1996); Arkansas, ARK. CODE ANN. § 4-27-202(B)(3)(i) (1996); California, CAL. CORP. CODE § 204(a)(10)(iii) (West 1990); Connecticut, CONN. GEN. STAT. § 33-636(b)(4)(B) (1997); Georgia, GA. CODE ANN. § 46-3-321(b)(3)(A)(i) (1992); Idaho, IDAHO CODE § 43-204B (1996), which relates to corporate bylaws; Illinois, 805 ILL. COMP. STAT. ANN. 5/2.10(b)(3)(i) (West Supp. 1998); Iowa, IOWA CODE ANN. § 490.832 (West 1991); Kansas, KAN. STAT. ANN. § 17-6002(b)(8)(A) (1995); Kentucky, KY. REV. STAT. ANN. § 271B.2-020(2)(d)(1) (Michie 1989); Louisiana, LA. REV. STAT. ANN. 12:24(C)(4)(a) (1994); Massachusetts, MASS. GEN. LAWS ANN. ch. 156B, § 13(b)(1½) (West 1992); Minnesota, MINN. STAT. ANN. § 300.083 subd. 2(3) (West 1985 & Supp. 1998), which excludes cases of "improper benefit" from mandatory indemnification; Nevada, NEV. REV. STAT. ANN. § 78.037(1)(a) (1994), which exempts acts of "intentional misconduct"; New Hampshire, N.H. REV. STAT. ANN. 292:2(V-a)(a)(1) (Supp. 1997); New Jersey, N.J. STAT. ANN. § 14A:2-7(3)(a) (West Supp. 1998); New York, N.Y. BUS. CORP. LAW § 402(b)(1) (Consol. Supp. 1998); Oklahoma, OKLA. ST. ANN. tit. 18 § 1006(B)(7)(a) (West Supp. 1998); Oregon, OR. REV. STAT. § 60.047(2)(d)(A) (1997); Pennsylvania, 15 PENN. CONSOL. STATS. § 1713(a)(2) (1996), which is applicable to corporate bylaws; Rhode Island, R.I. GEN. LAWS § 7-1.1-48(a)(6)(i) (1992); South Carolina, 11 S.C. CODE ANN. REG. § 33-2-102(e)(1) (1990); South Dakota, S.D. CODIFIED LAWS § 47-2-58.8 (1991); Tennessee, TENN. CODE ANN. § 48-12-102(b)(3)(A) (1995); Utah, UTAH CODE ANN. § 3-1-13.1(1)(a) (1995); and Wisconsin, WIS. STAT. ANN. § 180.0851(2)(a)(1) (West 1992), which excludes duty-of-loyalty breaches from mandatory indemnification.

On the other hand, there is reason to believe that parties have some limited ability to modify the COD contractually, *not* by limiting damages, but instead by crafting an express definition of a "corporate opportunity." *See, e.g.*, *American Inv. Co. v. Lichtenstein*, 134 F. Supp. 857 (E.D. Mo. 1955) (permitting a corporation to adopt a policy excluding a certain activity from the operation of the COD);

pursue the prospect at will. On the other hand, if a corporate opportunity is found to exist, the inquiry proceeds to node *B*, where the court attempts to ascertain whether the fiduciary has fully disclosed the opportunity (along with her interest in it) to the corporation. If she has not, then any authorization, approval, or ratification by the firm is voidable, and an appropriation of the project by the agent constitutes a breach of fiduciary duty. Conversely, if the fiduciary discloses fully, the inquiry proceeds to node *C*, where the corporation may “reject” the tendered opportunity, thereby offering it back to the fiduciary. If rejection occurs, then the fiduciary may freely appropriate the project subject to the conditions (if any) attached to the rejection. On the other hand, if the corporation fails to reject (or it rejects “improperly”²¹), the fiduciary may not appropriate the project without incurring liability. Finally, at those terminal nodes *X*₁ and *X*₂, which signify a breach of fiduciary duty, a court imposes the applicable remedy.

FIGURE 1. A SIMPLE ROAD MAP OF THE CORPORATE OPPORTUNITIES DOCTRINE

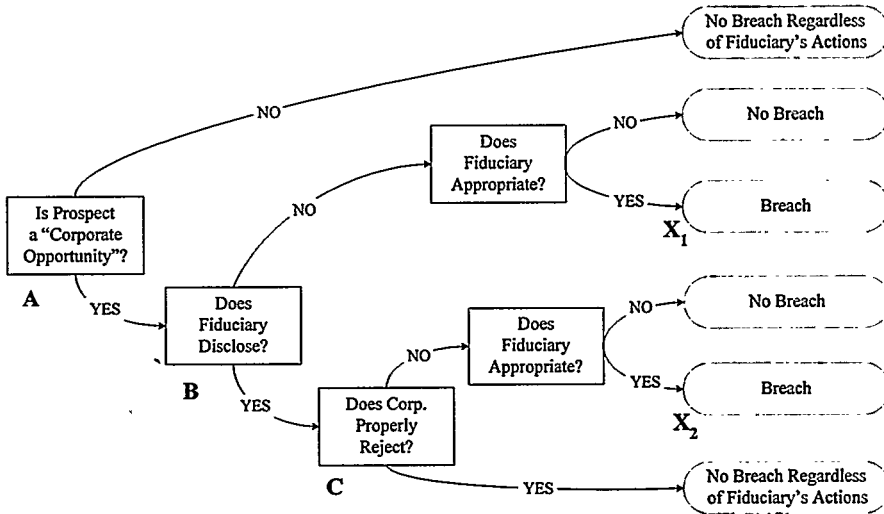

As noted in the Introduction, the practical application of the above algorithm has proven much more elusive than its rhetorical structure, both for courts and for legal scholars. While a comprehensive review of these difficulties is beyond the scope of this Article, some of the important details found at each node are sketched out in the Sections that follow.

see also AMERICAN LAW INST., PRINCIPLES OF CORPORATE GOVERNANCE [hereinafter ALI PCG] § 5.05(a) (allowing certain opportunities to be rejected in advance by the corporation).

21. See *infra* text accompanying notes 66-68 (defining proper rejection).

A. *Characterization Tests (Node A)*

Typically, the first task for a court in a corporate opportunities case is to identify whether the disputed project is, in fact, a “corporate opportunity.” This single determination has proven to be the most confusing in practice, and jurisdictions (and even courts within the same jurisdiction) have oscillated among numerous characterization tests, summarized below. Perhaps reflecting the disarray that permeates current doctrine, the tests described below tend to overlap in a number of contexts.²²

1. *The “Line-of-Business” Test*

Under the most prominent diagnostic test, a new business prospect constitutes a corporate opportunity if it is deemed to fall within the firm’s “line of business.” According to most judicial accounts, this test pulls within its ambit any project that the corporation—given its current assets, knowledge, expertise, and talents—could adapt itself to pursue. Originally articulated in the Delaware case of *Guth v. Loft, Inc.*,²³ the line-of-business test (or a close variant) has now become preeminent.²⁴

Most opinions purporting to apply the line-of-business test frequently employ a metaphorical trope of “distance” to characterize the strength of the corporation’s proprietary claim over the disputed project. In particular, the determination of whether an opportunity is within a firm’s line of business turns on the court’s perception of the relative proximity between the project’s requirements on the one hand, and the corporation’s expertise on the other. Courts that use this approach view their task as evaluating the relative burdens and difficulties that the firm might have in bridging this specialization gap through adaptation of its managerial strategies, production techniques, capital structure, and the like.²⁵ Once this distance reaches a critical threshold, the

22. In fact, legal scholars have noted that courts will often pronounce one test and then proceed to apply another. *See, e.g., Chew, supra* note 2, at 465-66.

23. 5 A.2d 503 (Del. 1939). In *Guth*, the Delaware Supreme Court framed the line-of-business inquiry as follows:

Where a corporation is engaged in a certain business, and an opportunity is presented to it embracing an activity as to which it has fundamental knowledge, practical experience and ability to pursue, which, logically and naturally, is adaptable to its business having regard for its financial position, and is one that is consonant with its reasonable needs and aspirations for expansion, it may be properly said that the opportunity is in the line of the corporation’s business.

Id. at 514.

24. Chew, for example, finds that as of 1989, *Guth v. Loft, Inc.* was the single most cited case among reported COD decisions. *See Chew, supra* note 2, at 455. Moreover, a number of prominent states (other than Delaware) currently follow the line-of-business test articulated in *Guth* (either exactly or with a close variant), including California, Connecticut, Illinois, and Ohio. *See, e.g., Kelegian v. Mgrdichian*, 39 Cal. Rptr. 2d 390, 393-94 (Ct. App. 1995); *Katz Corp. v. T.H. Canty & Co.*, 362 A.2d 975, 979 (Conn. 1975); *Levy v. Markal Sales Corp.*, 643 N.E.2d 1206, 1214-15 (Ill. App. Ct. 1994); *Hubbard v. Pape*, 203 N.E.2d 365, 368 (Ohio Ct. App. 1964).

25. *See, e.g., Balin v. Amerimar Realty*, No. 12896, 1996 Del. Ch. LEXIS 146, at *1 (Nov. 15, 1996); *Miller v. Miller*, 222 N.W.2d 71 (Minn. 1974); *Klinicki v. Lundgren*, 695 P.2d 906 (Or. 1985); *Imperial Group, Inc. v. Scholnick*, 709 S.W.2d 358 (Tex. Ct. App.—Tyler 1986, writ ref’d n.r.e.). In

burdens of adaptation are apparently deemed to be so large that the project no longer is in the firm's line of business. While perhaps not mentioned explicitly in every case, this conceptual approach appears to have clear utilitarian underpinnings. In fact, one prominent legal commentator has concluded that the line-of-business test is "not a mere exercise in conceptual classification" but is rather "a rough and ready inquiry into economic efficiency."²⁶

Despite this commonality, judicial opinions appear to vary substantially in prescribing the universe of circumstances in which a project falls within the firm's cognizable line of business.²⁷ For some courts, this domain is surprisingly small, encompassing only those opportunities that either are clearly linked to a corporation's existing operations or would put the fiduciary in direct competition with the firm's current endeavors.²⁸ Other courts have prescribed a larger domain, measuring relative similarity in terms of potential profitability and whether the pursuit of the opportunity presents a "practical advantage" to the corporation²⁹ or fits within its prospective plans for expansion.³⁰ Still others have expanded this domain further still, utilizing a test that ensnares any project that the corporation has the technological and financial *ability* to pursue and develop, apparently without regard to what is economically practical for the firm to undertake.³¹ In addition to the case law, the American Law Institute's *Principles of Corporate Governance* utilizes what is essentially an intermediate line-of-business test (albeit one that

particular, the fact that a disputed project appears to fall within the "long-range plans" of the corporation may constitute strong evidence that the project is within the firm's line of business.

While the distance metaphor is most applicable to the line-of-business test, a similar conceptual intuition is present in others. *See, e.g.*, Hopt, *supra* note 2, at 299 (describing the lack of clarity in the tests but noting that "[t]hey all try to describe points on a scale between an asset or business which undoubtedly belongs to the corporation . . . and an opportunity or chance which has nothing to do with the corporation and its business" (citation omitted)).

26. CLARK, *supra* note 2, at 227.

27. *See id.* at 228 (noting that a court could interpret the line-of-business test very narrowly or very broadly).

28. *See* Castleman *ex rel.* Thorpe v. CERBCO, Inc., 676 A.2d 436, 443 (Del. 1996) (noting that "[g]enerally, the corporate opportunity doctrine is applied in circumstances where the director and the corporation compete against each other" and that "those transactions which [are] not economically rational alternatives need not be considered by a court evaluating a corporate opportunity scenario"); Johnston v. Greene, 121 A.2d 919 (Del. 1956) (allowing a corporate director to retain patents related to business that was offered to the corporation); Guth, 5 A.2d at 513 (stating that "[t]he real issue is whether the opportunity . . . was so closely associated with the existing business activities of [the plaintiff], and so essential thereto, as to bring the transaction within that class of cases [in which appropriation] would throw the corporate officer . . . into competition with his company"); Turner v. American Metal Co., 50 N.Y.S.2d 800 (App. Div. 1944) (holding that a molybdenum mining venture was not sufficiently related to the *ongoing* business of a metal company dealing in copper, lead, zinc, gold, and silver, and the smelting, refining, and marketing of such metals, to constitute a corporate opportunity); Solimine v. Hollander, 16 A.2d 203 (N.J. Ch. 1940) (dismissing a derivative action against directors acting in their individual capacities).

29. *See, e.g.*, David J. Greene & Co. v. Dunhill Int'l, Inc., 249 A.2d 427 (Del. Ch. 1968); Paulman v. Kritzer, 219 N.E.2d 541 (Ill. App. Ct. 1966) (applying Delaware law), *aff'd* 230 N.E.2d 262 (Ill. 1967); Schildberg Rock Prods. v. Brooks, 140 N.W.2d 132 (Iowa 1966).

30. *See, e.g.*, Central Ry. Signal Co. v. Longden, 194 F.2d 310 (7th Cir. 1952); Rosenblum v. Judson Eng'g Corp., 109 A.2d 558 (N.H. 1954); Turner, 50 N.Y.S.2d at 800.

31. *See, e.g.*, Irving Trust Co. v. Deutsch, 73 F.2d 121, 124 (2d Cir. 1934) (prohibiting fiduciaries from pursuing any opportunities); Paulman, 219 N.E.2d at 545 (same).

distinguishes between officers and directors). Section 5.05 proscribes projects in which a director or senior executive knows or has reason to know that the corporation is interested, *and* all projects that a senior executive has reason to know are closely related to the corporation's current or anticipated future business.³²

A number of jurisdictions that apply the line-of-business test have also embraced its negative corollary, affording an affirmative defense to appropriating fiduciaries who can argue convincingly that the corporation was unable to pursue the opportunity itself.³³ While the "incapacity" defense can take a number of different forms, three are most prevalent. In one strand of cases, fiduciaries have argued that the corporation was financially unable to pursue the opportunity (due to liquidity constraints, bankruptcy, and the like).³⁴ In another, fiduciaries' arguments center around the corporation's legal inability due to ultra vires concerns, existing negative injunctions, or prospective antitrust problems.³⁵ In a third (but somewhat less successful) strand of cases, defendants have asserted that corporate incapacity stemmed from more generic business constraints, such as a lack of appropriate personnel, lack of profitability, or refusals by third parties to deal with the corporation,³⁶ that rendered the project de facto unavailable to the firm.³⁷ Regardless of the route, however, a fiduciary who successfully asserts an

32. See ALI PCG, *supra* note 20, § 5.05 (1992). In addition to this "project-based" characterization, the ALI Principles also take into account (for outside directors) the source of the information when it comes to directors. See *infra* text accompanying notes 57-59. The ALI approach has now been embraced by a few courts, and it is cited favorably by others. See, e.g., *Northeast Harbor Golf Club v. Harris*, 661 A.2d 1146, 1149 (Me. 1995); *Demoulas v. Demoulas Super Mkts.*, 677 N.E.2d 159, 181 n.36 (Mass. 1997); *Derouen v. Murray*, 604 So. 2d 1086 (Miss. 1992); *Klinicki v. Lundgren*, 695 P.2d 906, 917-20 (Or. 1985).

33. See, e.g., *Castleman ex rel. Thorpe v. CERBCO, Inc.*, 676 A.2d 436, 443 (Del. 1996) ("[T]hose transactions which were not economically rational alternatives [for the corporation to pursue] need not be considered by a court evaluating a corporate opportunity scenario.").

34. See *Borden v. Sinskey*, 530 F.2d 478, 493 (3d Cir. 1976); *Thorpe*, 676 A.2d at 443; *Broz v. Cellular Info. Sys.*, 673 A.2d 148, 155 (Del. 1996); *Northeast Harbor Golf Club*, 661 A.2d at 1149; *Urban J. Alexander Co. v. Trinkle*, 224 S.W.2d 923, 928 (Ky. 1949).

35. See *Borden*, 530 F.2d at 493; *Alexander & Alexander v. Fritzen*, 542 N.Y.S.2d 530, 535 (App. Div. 1989); *Urban J. Alexander Co.*, 224 S.W.2d at 928. Despite the sporadic success of such arguments, courts are increasingly limiting the incapacity defense only to cases where the fiduciary fully discloses but does not receive proper rejection before appropriating. See, e.g., *Demoulas*, 677 N.E.2d at 181.

36. See *Energy Resources Corp. v. Porter*, 438 N.E.2d 391, 394 (Mass. App. Ct. 1982).

37. Courts have rejected such arguments with virtual unanimity, expressing wariness about the verifiability of such alleged incapacities and the concomitant incentive of the fiduciary to claim that such barriers existed (when in fact they did not). See, e.g., *Regal-Beloit Corp. v. Drecoll*, 955 F. Supp. 849, 863 (N.D. Ill. 1996) (noting that in the absence of disclosure, it is impossible to test a fiduciary's assertion that a corporation could not pursue an opportunity because of a third party's refusal to deal); *Energy Resources Corp.*, 438 N.E.2d at 394 (rejecting a refusal to deal defense and stating that "[w]ithout full disclosure, it is too difficult to verify the unwillingness to deal and too easy for the executive to induce the unwillingness"); *Production Finishing Corp. v. Shields*, 405 N.W.2d 171 (Mich. Ct. App. 1986); *Imperial Group, Inc. v. Scholnick*, 709 S.W.2d 358 (Tex. Ct. App.—Tyler 1986, writ ref'd n.r.e.). In fact, in some jurisdictions courts have been sufficiently troubled by verifiability problems to disallow the incapacity defense altogether, effectively requiring the insider to tender any opportunity about which she learns as a result of her affiliation with the corporation. See, e.g., *Irving Trust Co. v. Deutsch*, 73 F.2d 121 (2d Cir. 1934); *Kerrigan v. Unity Sav. Ass'n*, 317 N.E.2d 39 (Ill. 1974).

incapacity defense is not required to disclose before appropriating the project for her own account.³⁸

2. The “Interest-or-Expectancy” Test

Despite the line-of-business test’s prominence in modern case law, it was predated by what is now perceived to be a narrower common-law doctrine, proscribing only those projects in which the corporation has an active commercial interest or expectancy. The “interest” component of this approach refers to projects over which the corporation has an existing contractual right.³⁹ The “expectancy” component proscribes projects that, while not already secured through an express contract, are likely, given current rights, to mature into contractual rights at some future date.⁴⁰ Of particular relevance here are so-called “relational” contracts between the corporation and repeat clients, in which periodic extensions are not expressly provided for but can be reasonably assumed.⁴¹

Perhaps because the interest-or-expectancy test ultimately defines a corporate opportunity by reference to *current* (rather than prospective) activities of the firm, courts applying the test appear to be less troubled than their line-of-business counterparts by the task of marking the boundaries for corporate opportunities. Indeed, the narrow reach of the test effectively limits it to those projects about which the firm (by virtue of its existing contractual rights) already has actual or reasonable knowledge. Despite its administrative convenience, however, the test has been criticized as under-inclusive because it reaches *only* those projects over which the corporation’s proprietary claim is relatively mature.⁴² Because many investments do not reap rewards (in, say,

38. See, e.g., *Broz v. Cellular Info. Sys.*, 673 A.2d at 157. It should be noted, however, that even when disclosure is not required, some courts view disclosure and rejection by the corporation as a type of “safe harbor” against future liability. See *id.* at 157.

39. See, e.g., *Lagarde v. Anniston Lime & Stone Co.*, 28 So. 199 (Ala. 1900) (holding that corporate fiduciaries who purchased a two-thirds interest in a limestone quarry appropriated a corporate opportunity as to a portion of their purchase, since the quarry had already secured a contractual agreement from the seller for that portion). Some courts applying the interest-or-expectancy test have placed the additional requirement that the opportunity must be “necessary,” “essential,” or at least extremely important to the corporation before a court will deem there to be a prospective interest. See CLARK, *supra* note 2, at 226.

40. See CLARK, *supra* note 2, at 225; COX ET AL., *supra* note 2, at 237.

41. Ian R. Macneil, *Contracts: Adjustment of Long-Term Economic Relations Under the Classical, Neoclassical, and Relational Contract Law*, 72 N.W. U. L. REV. 854 (1978).

42. See CLARK, *supra* note 2, at 226-27 (noting that the interest-or-expectancy test is easier for executives to meet than other tests, and that its notion of duty is a negative conception, rather than an affirmative obligation); COX ET AL., *supra* note 2, at 237 (labeling the test as “lax” toward defendants); Chew, *supra* note 2, at 460. The narrow reach of the interest-or-expectancy test is illustrated in *Lagarde*, in which the Alabama Supreme Court held that “[g]ood faith to the corporation does not require of its officers that they steer from their own to the corporation’s benefit, enterprises, or investments, which, though capable of profit to the corporation, have in no way become the subjects of their trust or duty.” *Lagarde*, 28 So. at 202.

Underscoring this narrow scope is the observation that neither component of the test seems to add much to preexisting rights under other common-law doctrines. With respect to the “interest” test, were the fiduciary to transact with a third party for a project in which the corporation already had an existing contractual interest, the corporation could no doubt bring a breach-of-contract action against that third

the form of new customers) until long after an initial investment, the argument goes, a characterization rule that protects only mature rights runs the risk of decreasing the ex ante incentives of the shareholders to invest in long-term projects.⁴³

3. *The "Fairness" Test*

Over the last twenty-five years, a small number of jurisdictions have attempted to develop a test of "fairness" to characterize the existence of a corporate opportunity. Under such an approach, an opportunity is deemed to be a corporate one if a fiduciary's appropriation would not satisfy "ethical standards of what is fair and equitable [to the corporation in] particular sets of facts."⁴⁴ Much like the line-of-business test, the fairness test may proscribe either existing or prospective activities of the firm. Accordingly, courts employing this approach frequently encounter line-drawing problems when deciding which projects qualify as corporate opportunities.

An even more vexing concern for courts employing a fairness test, however, is the challenge of articulating exactly what "fairness to the corporation" means. Jurisdictions adopting this test have had little success in articulating—beyond recapitulations of circular rhetoric—the substantive contours of a fairness approach. Elaborate attempts to supply them appear to do little more than advocate judicial casuistry and flexibility,⁴⁵ often offering digests of guiding principles that essentially replicate other extant characterization tests.⁴⁶ Corporations scholars likewise have had difficulties

party. Further still, a direct action against the fiduciary also might be available under the tort doctrine of interference with contract, assuming that the fiduciary had knowledge of the existing right. *See, e.g., Chew, supra* note 2, at 460 n.40. *But see United Teacher Assocs. Ins. Co. v. MacKeen & Baily, Inc.*, 847 F. Supp. 521, 538 (W.D. Tex. 1994) ("Unlike tortious interference with business or contractual relations, the corporate opportunity doctrine does not require the plaintiff to show a reasonable probability that it would have capitalized on the lost investment opportunity."). The "expectancy" component likewise may be redundant with other common-law rights. If the offered project is one from which the corporation, while having no contractual rights, could nonetheless stand to benefit, corporate opportunity liability may coincide with the doctrine of interference with prospective economic advantage. To the extent that the expectancy test provides another cause of action, it seems to be one of an implied covenant by the insider not to appropriate certain types of projects from the firm.

43. *See, e.g., COX ET AL., supra* note 2, at 237.

44. *Durfee v. Durfee & Canning, Inc.*, 80 N.E.2d 522, 529 (Mass. 1948) (citing HENRY WINTHROP BALLANTINE, *BALLANTINE ON CORPORATIONS* 204-05 (rev. ed. 1946)).

45. *See, e.g., Annotation, Fairness to Corporation Where "Corporate Opportunity" Is Allegedly Usurped by Officer or Director*, 17 A.L.R.4th 479 § 2 (1996) (collecting authorities and concluding that "[s]ince the question whether a director or officer has appropriated for himself something that in fairness should belong to his corporation is a factual one to be decided by reasonable inference from objective facts, . . . [t]he result in any particular case has hinged on the surrounding circumstances and particular actions that allegedly constituted a breach of the corporate opportunity doctrine").

46. Ballantine lists a number of factors implicated by the tests, including whether the opportunity was of special value to the corporation, whether the corporation was actively negotiating for the opportunity, whether the corporation was in a financial position to pursue the opportunity, and whether the fiduciaries would be put in an "adverse and hostile position" to the corporation; whether the fiduciaries received the opportunity because of their corporate positions, whether the fiduciaries were delegated to pursue the opportunity on behalf of the corporation, whether the fiduciaries used corporate resources in identifying or developing the opportunity, and whether the fiduciaries intended to resell the opportunity to the corporation. *See BALLANTINE, supra* note 44, at 206.

formulating a theory of fairness as a foundational premise for fiduciary duties, leading some scholars to argue (in a more general context) that the very notion of “fairness” has vastly more procedural than substantive significance.⁴⁷

The problems do not stop there. For even if courts could articulate a substantive account of fairness in this context, the task of developing a tractable and faithful doctrine presents additional obstacles. One of the chief difficulties stems from the complex relationship between ex post allocations (where the COD operates) and the labor market for fiduciaries (where it does not). Indeed, if courts were to articulate a judicial notion of “fairness” different from those that would emerge from competitive labor markets, it would not be surprising to see the parties displace the COD with express definitions of their own, either in employment contracts or in corporate charters. Because the current structure of the COD is essentially a default rule, such countermanding terms are eminently plausible.⁴⁸

The proponent of a fairness criterion might respond that one could overcome this difficulty by implementing an immutable—rather than default—fairness doctrine, thereby prohibiting the parties from contracting around the rule. This response, however, is not without difficulties of its own. In addition to requiring significant reform of the current COD, an immutable substantive rule may not solve the problem of ex ante contractual negation. Indeed, by the time a corporate opportunities dispute arises, the parties in most cases have already executed (and to some extent performed) a contract that may have numerous other terms, including direct compensation schemes, signing bonuses, other perquisites, and nonpecuniary benefits. Their ex ante negotiations over those ancillary terms may well depend, in part, on their expectations about the prospective allocation of corporate opportunities. Thus, were a jurisdiction to adopt an immutable “fairness” criterion that tended (for instance) to favor the interests of shareholders on distributional grounds, then corporate fiduciaries—anticipating this judicial preference—might well demand more attractive remuneration for their services. A plausible result of such contracting behavior, then, is that a mandatory fairness norm would merely change the timing and method of division, not any underlying distributional asymmetry.⁴⁹ One might, of course, attempt to plug this hole using additional immutable rules to govern not only corporate opportunities but also all other material elements of pecuniary and nonpecuniary compensation. While theoretically possible, such reforms would require an

47. See Lawrence E. Mitchell, *Fairness and Trust in Corporate Law*, 43 DUKE L.J. 425, 426-29 (1993).

48. *But see supra* note 20 (noting that parties may be somewhat constrained in their ability to limit damages contractually).

49. See Frank H. Easterbrook & Daniel R. Fischel, *Contract and Fiduciary Duty*, 36 J.L. & ECON. 425, 426-27 (1993). In fact, when immutable distributional rules induce the parties to “undo” that allocation in upstream contracting, the result may also be strictly pareto-inferior to a default rule that would allow a direct countermanding of the distributional rule.

implausibly high degree of confidence in a court's administrative and information-gathering capabilities.⁵⁰

These shortcomings have, in part, led commentators and courts to proclaim that the fairness test as applied to the COD merely muddies the waters,⁵¹ adds new layers of confusion to already murky doctrine,⁵² and provides no predictable guidelines.⁵³ Consequently, the fairness test has held only modest sway within courts and among academics.

4. *Alternative Tests, Composites, and Hybrids*

In addition to the pure approaches described above, many courts over the years have varied, combined, hybridized, and supplemented the traditional tests in an attempt to refine the characterization rules. The amalgam of the line-of-business and the interest-or-expectancy tests seems particularly strong in this regard,⁵⁴ but other combinations are possible. Minnesota courts, for instance, conduct a two-step analysis that is effectively a combination of the line-of-business test and the fairness inquiry.⁵⁵ Hybrid approaches of this latter sort generally have met with considerable disapprobation, and, in the words of one court, "pile[] the uncertainty and vagueness of the fairness test on top of the weaknesses in the line-of-business test."⁵⁶

In other cases, courts have adopted analytical frameworks that sidestep the "project-based" inquiry, concentrating instead on the *source* of the fiduciary's information. The ALI Principles, which adopt just such an approach alongside the line-of-business test, state that a corporate opportunity constitutes any new business prospect that the fiduciary: (1) learns of in her corporate capacity; (2) has reason to know is being offered to the corporation; or (3) acquires through the use of corporate information or property, if the

50. As noted in the introduction, the results of the next section suggest that a type of immutable rule may well play a role in an "optimal" COD. The immutable rule that I advocate, however, is one that prohibits renegotiation; it does not prohibit certain express terms *ex ante*. Moreover, I argue that a "no-renegotiation" rule is consistent with what the parties would want at the time of bargaining, because it helps them to overcome a commitment problem. See *infra* notes 226-228 and accompanying text.

51. See CLARK, *supra* note 2, at 229.

52. See *Northeast Harbor Golf Club, Inc. v. Harris*, 661 A.2d 1146, 1149-50 (Me. 1995); Brudney & Clark, *supra* note 2, at 998-99 n.2.

53. See Chew, *supra* note 2, at 462.

54. In the Delaware Supreme Court's most recent pronouncement in this area, for example, the corporation's "line of business" and its "interest or expectancy" are both named as applicable tests that should be factored into an evaluation of the facts and circumstances of each case. *Broz v. Cellular Info. Sys.*, 673 A.2d 148, 155 (Del. 1996). Interestingly, however, the Delaware court's conception of the interest-or-expectancy test appears to be somewhat broader than its historical predecessors in that it need not involve *current* contractual rights. See *id.* at 156 (stating that "[f]or the corporation to have an actual or expectant interest in any specific property, there must be some tie between that property and the nature of the corporate business" (quoting *Johnston v. Greene*, 121 A.2d 919, 924 (Del. 1956) (alteration in original))).

55. See *Miller v. Miller*, 222 N.W.2d 71, 81 (Minn. 1974). Under the *Miller* two-part test, the first step is to determine whether the disputed project is sufficiently related or of special importance to the corporation to justify sanctions against appropriation. If so, then the inquiry proceeds to determine whether the appropriating fiduciary violated the duty of loyalty and fair dealing she owed to the corporation. See *id.*

56. *Northeast Harbor Golf Club*, 661 A.2d at 1150.

fiduciary has reason to know that the corporation would be interested in the prospect.⁵⁷ While this source-based approach plays a role in a number of decisions,⁵⁸ others have leveled significant criticism at it, citing the virtual impossibility of comparing the relative contributions of the fiduciary's individual and titular characteristics in attracting the project.⁵⁹

B. *Disclosure and Rejection (Nodes B and C)*

Once a court deems that a disputed prospect constitutes a corporate opportunity, the fiduciary inherits a duty similar to the one that applies to insider trading. Either she must promptly disclose the existence of the project (along with her personal interest in it) to the corporation, or she must abstain from appropriating it.⁶⁰ In requiring such disclosure, the doctrine essentially grants the corporation a right of first refusal on the project. Accordingly, most jurisdictions specify procedural protocols by which the corporation may reject a disclosed opportunity, thereby empowering the fiduciary once again to pursue it individually.⁶¹

A theme that permeates the disclosure cases is that only *full* disclosure of all relevant details of the project and the fiduciary's interest enables the corporation to make an informed decision about whether to reject the opportunity.⁶² Most cases hold that absent complete disclosure a later rejection

57. See ALI PCG, *supra* note 20, § 5.05(b).

58. See *Central Ry. Signal Co. v. Longden*, 194 F.2d 310, 319 (7th Cir. 1952); *Guth v. Loft, Inc.*, 5 A.2d 503, 511 (Del. 1939).

59. See, e.g., CLARK, *supra* note 2, at 230 ("The distinction between official and individual capacities can create endless argument about the proper characterization of facts. . . . [I]t is often difficult to decide when an executive has stepped completely outside of his role."); see also David Clayton Carrad, *The Corporate Opportunity Doctrine in Delaware: A Guide to Corporate Planning and Anticipatory Defensive Measures*, 2 DEL. J. CORP. L. 1, 2 (1977) (noting the difficulty of clearly demarcating the fiduciary's role).

The apparent rationale for the so-called "source rule" is the argument that a rational fiduciary would never contract away the right to pursue projects she would likely have received even if the firm did not exist. This assertion itself seems open to some doubt, particularly if the firm were willing to increase the fiduciary's wages to secure those rights.

60. See *Dunaway v. Parker*, 453 S.E.2d 43, 51 (Ga. App. 1994) (noting this duty in corporate opportunities cases); see also *Dirks v. SEC*, 463 U.S. 646, 653 (1983) (describing the so-called "*Cady, Roberts*" duty to disclose or abstain in insider trading cases (citing *In re Cady, Roberts & Co.*, 40 S.E.C. 907, 911 & n.13 (1961))).

61. These procedures are usually similar to those necessary to "cleanse" any other interested transaction. See, e.g., ALI PCG, *supra* note 20, § 5.05 cmt. a (1994) (noting that disclosure and rejection doctrine for the COD are similar to those of § 5.02). For a good description of Delaware law on self-dealing transactions, see *In re Wheelabrator Technologies Shareholders Litigation*, 663 A.2d 1194, 1201-03 (Del. Ch. 1995).

62. One court has described the full-disclosure requirement thus:

[I]f the doctrine of business opportunity is to possess any vitality, the corporation or association must be given the opportunity to decide, upon full disclosure of the pertinent facts, whether it wishes to enter into a business that is reasonably incident to its present or prospective operations. If directors fail to make such a disclosure and to tender the opportunity, the prophylactic purpose of the rule imposing a fiduciary obligation requires that the directors be foreclosed from exploiting that opportunity on their own behalf.

Kerrigan v. Unity Savs. Ass'n, 317 N.E.2d 39, 43-44 (Ill. 1974). Full disclosure plays a central role in the ALI test as well. See ALI PCG, *supra* note 20, § 5.05(a) cmt. ("If the opportunity is not offered to the corporation, the director or senior executive will not have satisfied § 5.05(a).").

is voidable by the corporation or its shareholders.⁶³ Moreover, in many jurisdictions a failure to disclose important characteristics of the project can also render the incapacity defense unavailable, and it may even toll the statute of limitations.⁶⁴ While the full-disclosure requirement is easily articulated, it is applied with somewhat more difficulty, particularly in situations where a court cannot easily verify what the fiduciary knew (and did not know) about the project when she disclosed and procured rejection from the corporation. Such verification problems appear to be commonplace in the faulty disclosure cases.⁶⁵

To reject an opportunity, the corporation must follow a procedure similar to that of more generic control transactions. A number of routes are available, but the most common consists of approval or ratification by either an affirmative vote of the disinterested directors, and, in the case of a senior executive, approval by a disinterested superior (both subject to review under the relatively lax business judgment rule),⁶⁶ or alternatively, approval or ratification by the disinterested shareholders (subject to a “waste” standard of review).⁶⁷ Even in the absence of either of the above two forms of rejection, a disclosing fiduciary may still be able to demonstrate proper rejection by demonstrating that appropriating the opportunity was “fair” to the corporation.⁶⁸

An interesting special case for disclosure occurs when the fiduciary has disclosed fully, but the corporation proceeds to do nothing. A few jurisdictions have developed what amounts to a doctrine of “implied refusal” for such situations, allowing the fiduciary to pursue the opportunity if the corporation does not act upon it within a reasonable time following disclosure.

63. See *McCabe Packing Co. v. United States*, 809 F. Supp. 614, 617 (C.D. Ill. 1992) (“Under Illinois law, the business decision of a corporation not to engage in a particular line of business is beyond any questioning by the courts, as long as the corporation was given the opportunity upon full disclosure of the facts to decide whether to enter the particular line of business.”); *Havlicek/Fleisher Enters. v. Bridgeman*, 788 F. Supp. 389, 395 (E.D. Wis. 1992) (“Without full disclosure, an informed acceptance or rejection of a corporate opportunity cannot be made.”); *Castleman ex rel. Thorpe v. CERBCO, Inc.*, 676 A.2d 436, 437 (Del. 1996).

64. See *Fletcher*, *supra* note 5, at 285; *supra* text accompanying note 5.

65. In Part III, I shall define “relevant” details as any characteristics that affect the profitability of the project to the firm or fiduciary, respectively. This definition is not significantly different from the ALI definition, which adopts a “materiality” standard for disclosure, including all facts which “there is a substantial likelihood that a reasonable person would consider . . . important under the circumstances” ALI PCG, *supra* note 20, § 1.25 (adopting the test stated in *TSC Indus. v. Northway, Inc.*, 426 U.S. 438, 449 (1976)).

66. See Del. Gen. Corp. L. § 144(1); ALI PCG, *supra* note 20, § 5.05(a)(3)(B) (taking a corporate opportunity is acceptable if the disinterested directors reject the opportunity “in a manner that satisfies the standards of the business judgment rule”).

67. ALI PCG, *supra* note 20, § 5.02(a)(2)(d).

68. *Id.* § 5.05(c) cmt. It is interesting to note that the first two alternatives in this inquiry appear to be procedural, while the final one is (or at least purports to be) substantive. In fact, the comment to this section notes that “[t]he test of fairness is an objective test” requires the terms of the transaction to be in the “range of reasonableness.” The comment proceeds to list as its first factor, however, “the process by which the transaction was shaped and approved.” *Id.* § 5.02 (a)(2)(A) cmt. As noted with the “fairness” characterization test described above, the cases and the commentators have generally failed to supply an operative standard for fairness, and contractarians have tended to be even more dubious of a court’s ability to pursue fairness considerations *ex post* while leaving *ex ante* behavior unchanged.

Defendants generally have been successful in such cases only when they argued that they acted in good faith by fully disclosing and did not use other corporate assets in pursuing the opportunity.⁶⁹ Once again, however, there is little inter-jurisdictional agreement about the implied rejection doctrine, and its viability remains uncertain.⁷⁰

C. *Remedy for Breach (Nodes X₁ and X₂)*

The remedy for appropriation of a business opportunity can be either legal or equitable, depending on the case in question. Unlike the standard remedies in other commercial settings, however, the monetary remedies in most corporate opportunity cases tend to be gains-based rather than harm-based.⁷¹ In fact, the presumptive remedy for such a breach is the imposition of a constructive trust on the disputed enterprise, effectively disgorging all of the fiduciary's verifiable profits (even if they exceed the corporation's provable loss, and even if there is *no* provable loss⁷²).

In cases where the appropriation is deemed to be particularly malicious, oppressive, or in bad faith, punitive damages may be awarded as well. But beyond this distinction, most courts appear to inquire very little about the *path* the fiduciary followed in breaching her duty. In terms of Figure 1, a fiduciary might have breached by completely failing to disclose (node X₁) or by disclosing but failing to secure proper rejection before pursuing the project (node X₂). Regardless of this path, most courts tend to impose a constructive trust on a breaching fiduciary as a default measure of damages. The likelihood of punitive damages, however, appears to be greater for appropriation following nondisclosure than it is for appropriation following full disclosure but absent refusal by the firm.⁷³

69. See, e.g., *Lussier v. Mau-Van Dev.*, 667 P.2d 804 (Haw. Ct. App. 1983); *Litwin v. Allen*, 25 N.Y.S.2d 667 (Sup. Ct. 1940); *Farber v. Servan Land Co.*, 662 F.2d 371 (Former 5th Cir. 1981); *CST, Inc. v. Mark*, 520 A.2d 469 (Pa. Super. Ct. 1987).

70. Compare ALI PCG, *supra* note 20, at §5.05(a) cmt. (requiring that the corporation "promptly" accept or reject the opportunity once it has been disclosed and offered, and that failure to accept the opportunity within a reasonable time will amount to a rejection of the opportunity), with 18B AM. JUR. 2D *Corporations* § 1788 (1985) (stating that "[t]he corporation's unwillingness to take advantage of the opportunity in question must be *clearly manifested*" (emphasis added)).

71. See *Milbank, Tweed, Hadley & McCloy v. Boon*, 13 F.3d 537, 543 (2d Cir. 1994) ("[B]reaches of a fiduciary relationship in any context comprise a special breed of cases that often loosen normally stringent requirements of causation and damages."); see, e.g., *Thorpe v. CERBCO, Inc.*, 676 A.2d 436, 445 (Del. 1996) ("Once disloyalty has been established, [Delaware law] require[s] that a fiduciary not profit personally from his conduct, and that the beneficiary not be harmed by such conduct."); *Guth v. Loft, Inc.*, 5 A.2d 503, 510 (Del. 1939) ("The rule, inveterate and uncompromising in its rigidity, does not rest upon the narrow ground of injury or damage to the corporation resulting from a betrayal of confidence, but upon a broader foundation of a wise public policy that, for the purpose of removing all temptation, extinguishes all possibility of profit flowing from a breach of the confidence imposed by the fiduciary relation.").

72. See 76 AM. JUR. 2D, *Trusts* § 232 (1992); 18B AM. JUR. 2D, *Corporations* § 1772 (1985) (noting that liability can obtain even if the corporation benefited from the fiduciary's appropriation).

73. See, e.g., *United Teachers Assocs. Ins. Co. v. MacKeen & Bailey, Inc.*, 847 F. Supp. 521, 543-44 (W.D. Tex. 1994); *Levy v. Markal Sales Corp.*, 643 N.E.2d 1206, 1221-23 (Ill. App. Ct. 1994). Moreover, the route increasingly appears to matter in the availability of the incapacity defense. See *supra* text accompanying notes 33-38.

D. *A Normative Quandary*

As the discussion above illustrates, current application of the COD is neither uniform nor predictable. Courts frequently employ dissimilar tests both to characterize corporate opportunities and to govern their disclosure. Moreover, even in those jurisdictions that nominally employ the same approach, surprisingly divergent results frequently emerge.⁷⁴ This heterogeneity presents a distinct normative challenge to those seeking greater clarity in the doctrine. For in order to proceed, one must first resolve a quandary about exactly what fiduciary duty law ought to accomplish. Or, to put it in more utilitarian terms: What should courts endeavor to maximize?

This is no trivial inquiry. Indeed, one need not venture far into the existing corporate scholarship to find a landscape riddled with discord over this solitary issue. Much of the debate, however, appears to hinge on a more fundamental disagreement over the appropriate “weight” that doctrine should accord shareholder welfare relative to that of other corporate constituencies. Although competing theories abound, three in particular have proven dominant: the “traditionalist” account; the “contractarian” account; and the “communitarian” account. Each deserves brief elaboration.

Traditionalists portray fiduciary duties as the doctrinal cousin to the law of trusts.⁷⁵ According to this account, a corporate fiduciary’s obligations are analogous to those of a common-law trustee: to administer and manage corporate property solely for the advantage of the shareholder beneficiaries. Consequently, the fiduciary is held to strict standards of comportment—standards that transcend the lowly “morals of the market place” and rise to a level of “the finest loyalty” to the firm’s residual claimants.⁷⁶ The fiduciary may neither use her position for self-interested dealing nor take any actions that conflict with the interests of the shareholders.⁷⁷ In essence, a traditionalist animates fiduciary law as a normative lexicography of sorts, mandating that courts rank shareholders’ welfare above that of any other constituency (including that of the fiduciary).

In spite of its venerable judicial pedigree and doctrinal bravado, the traditionalist account has proven largely incoherent, both in application and theory. It is not difficult to find prominent examples in the case law where courts, after invoking the moralistic rhetoric of uncompromising fidelity, proceed nonetheless to permit acts of self-dealing at the expense of corporate

74. I consider two such cases *infra* Section II.E.

75. See I AUSTIN WAKEMAN SCOTT, *THE LAW OF TRUSTS* § 2.5 (2d ed. 1956).

76. The quoted phrases derive from Judge Cardozo’s classic opinion in *Meinhard v. Salmon*, 249 N.Y. 458, 463-64 (1928), which likens the fiduciary duty of a partner to that of a trustee. The trustee analogy is frequently utilized elsewhere in corporations jurisprudence as well. See, e.g., *Dodge v. Ford Motor Co.*, 170 N.W. 668, 684 (Mich. 1919) (noting that although directors have considerable leeway to select a means to an end, that end—shareholder profit—is nondiscretionary); CLARK, *supra* note 2, § 7.6.1, at 244.

77. See William W. Bratton, *Game Theory and the Restoration of Honor to Corporate Law’s Duty of Loyalty*, in *PROGRESSIVE CORPORATE LAW* 139, 142 (Lawrence E. Mitchell, ed. 1995).

shareholders.⁷⁸ Moreover, most modern corporations statutes explicitly relax the strict prohibition on self-dealing, replacing it with a more restrictive policy that condone such transactions upon approval by disinterested directors or shareholders.⁷⁹ This doctrinal equivocation undoubtedly betrays a deeper theoretical difficulty in the traditionalist account: the realization that fiduciary relationships are, ultimately, *contractual* ones.⁸⁰ Indeed, no one is *required* to become a corporate fiduciary; she consents to do so voluntarily, and only then in exchange for compensation that makes entering such a relationship worthwhile. Similarly, shareholders will only be willing to pay such compensation if, all things considered, they believe it is in their best interests to do so.⁸¹

Perhaps stemming from this realization, a well-developed “contractarian” account of fiduciary law has become dominant in recent years. Contractarians view the fiduciary relationship as nothing more than a species of contract in which one party manages the assets of another. Accordingly, they assert that the normative role of corporate law is to facilitate this process by providing a set of default rights and duties designed to replicate those that the parties would negotiate *ex ante*.⁸² By providing such terms, the argument goes, corporate law can alleviate the necessity of negotiating and drafting such terms.⁸³ Consequently, the contractarian account instructs courts to accord weight not only to the welfare of shareholders, but also to that of corporate

78. See, e.g., *Broz v. Cellular Info. Sys.*, 673 A.2d 148 (Del. 1996); *Northeast Harbor Golf Club, Inc., v. Harris*, 661 A.2d 1146, 1150 (Me. 1995) (noting somewhat circularly that “[i]t is important to preserve some ability for corporate fiduciaries to pursue personal business interests that present no real threat to their duty of loyalty”); *Guth v. Loft, Inc.*, 5 A.2d 503 (Del. 1939); see also Bratton, *supra* note 77, at 144 (“[C]orporate fiduciary law equivocates as it imposes a norm of honor in the service of the interests of the shareholder-beneficiary. . . . But then, in a synchronizing mode, it carves out endless exceptions, case by case.”).

79. See, e.g., DEL. CODE ANN. tit. 8, § 144 (West 1997).

80. Such arguments have become dominant among both economists and law-and-economics scholars, who have come to view the firm fundamentally as a “nexus of contracts.” See, e.g., Jean-Jacques Laffont & David Martimort, *The Firm as a Multi-Contract Organization*, 6 J. ECON. & MGMT. STRATEGY 201 (1997).

81. An identical argument underscores an even broader normative claim that the entire law of trusts is, at its core, a contractual one. See Henry Hansmann & Ugo Mattei, *The Functions of Trust Law: A Comparative Legal and Economic Analysis*, 73 N.Y.U. L. REV. 434 (1998); John H. Langbein, *The Contractarian Basis of the Law of Trusts*, 105 YALE L.J. 625 (1995).

82. This view is currently the dominant theme in the law-and-economics literature. It was largely encapsulated in EASTERBROOK & FISCHER, *supra* note 4. A variation on this contractarian theme is provided by Ayres & Gertner, *supra* note 20, who argue that in certain situations, default rules should consciously diverge from the most likely preferred terms, in order to give a privately-informed party the proper incentives to reveal information. I take up this permutation at greater length in the Appendix.

83. In the context of the COD, this contractarian theme currently appears to be the dominant one. See, e.g., LARRY RIBSTEIN & PETER LETSOU, *BUSINESS ASSOCIATIONS* 544 (1996) (“The applicable rule arguably should minimize the need for customized contracts by matching the bargain firms and employees usually would make.”); Brudney & Clark, *supra* note 2, at 999 (noting that the COD “makes it unnecessary for a principal . . . to provide by contract an array of prohibitions against the agent diverting to himself the principal’s assets”); Cooter & Freedman, *supra* note 2, at 1067 (likening the optimal doctrine to the optimal contract).

fiduciaries, just as those parties themselves would do in an actual bargaining situation.⁸⁴

Some critics of the contractarian approach contend that the corporate contract differs from its more generic arm's length counterpart in at least two important ways. First, the terms of the corporate contract are usually set out in the charter by promoters, before investors (and sometimes even managers) have entered the relationship. This feature makes it costly for shareholders and fiduciaries to negotiate actively over the details of their relationship, particularly when doing so would require invoking the charter amendment process. Second, fiduciary relationships are perceived to implicate special problems of asymmetric information. Although many ordinary contracts are performed in an environment in which relevant information is observable and verifiable, fiduciaries tend to occupy an informationally privileged position, in which their knowledge and actions are either costly or impossible for shareholders to monitor.⁸⁵

While worthy of attention, neither of these purported criticisms seems sufficient to undermine the appropriateness of the normative contractual paradigm. Indeed, contract law is rife with examples in which bargaining is either truncated or nonexistent.⁸⁶ In fact, a lack of detailed bargaining is more often the rule than the exception in competitive product markets. Additionally, while the fiduciary relationship may be particularly susceptible to information asymmetries, it is not the unique form for such problems. Warranties, output contracts, exclusive dealing arrangements and surety contracts are all appropriately viewed as "contractual," even though each explicitly contemplates the presence of private information. Moreover, to the extent that either of the above objections represents a type of "transaction cost," it tends to amplify rather than diminish the importance of a well-crafted doctrine replicating a hypothetical bargain: For if parties are unable to negotiate effectively, the ultimate property rights allocation is likely to be dictated by the default legal rule.⁸⁷

84. See, e.g., Chew, *supra* note 2, at 444-55 (arguing that current doctrine places a disproportionately small value on the fiduciary's welfare). Chew makes a further argument that current doctrine also fails to take into account the welfare of other "societal" interests, such as the "successful development of opportunities" and the "development of entrepreneurial instincts." *Id.* at 452-54. It is unclear, however, how exactly society benefits from an efficient allocation between two parties. If the source of society's benefit is merely the prospect that other members of society are also potential parties in corporate contracts, then society's interest is identical to the parties' joint benefit and, thus, need not be considered as a separate interest.

85. See *supra* note 19.

86. A notable example of truncated bargaining within a contractual context is the so-called "option contract" (traditionally known as a "unilateral contract"), which an offeree may accept simply by tendering or initiating the invited performance, or tendering a beginning of it. See RESTATEMENT (SECOND) OF CONTRACTS § 45.

87. Additionally, contractarians assert, thick labor and capital markets justify the hypothetical bargain paradigm. If a promoter executes a charter that manifestly favors corporate fiduciaries, investors are unlikely to bid up the price of the firm's shares. Conversely, if the charter manifestly favored shareholders, potential fiduciaries would likely work elsewhere or demand greater wage compensation, which in turn would be capitalized into the share price. In either case, promoters will bear the brunt of inefficient terms in the charter.

Finally, a third normative theory of fiduciary duties, loosely described as the “communitarian” account, has commanded greater popularity in recent years.⁸⁸ Although they often disagree on specifics, communitarians are universally critical of attempts to animate fiduciary duties from hypothetical, bilateral contracts between shareholders and managers. To the contrary, they argue, the allocational decisions made within a firm can have significant stakes for numerous other constituencies, including employees, creditors, suppliers, customers, and surrounding communities. The corporation, residing at the intersection of these interests, seems the logical location for a legal clearinghouse of these varied interests. It makes little sense, then, for corporations law to attend myopically to only a subset of them.⁸⁹

This foundational claim made by most communitarians has already had an impact on corporations law. Over thirty states have now adopted so-called “constituency statutes,” which declare (in one form or another) that corporate boards of directors may take account of nonshareholder constituencies.⁹⁰ But perhaps more important for current purposes is the emerging view that communitarianism is not fundamentally incompatible with a contractualized model of the firm. Indeed, one interpretation of the communitarian project is that it merely calls for a more sophisticated form of contractarianism: one that truly envisions the firm as a contractual nexus for multiple constituent interests.⁹¹ Viewed in this sense, the communitarian critique spawns a modified normative theory of fiduciary duties: one that not only attends to shareholders’ and managers’ welfare, but also takes account of any other affected constituency.

In spite of communitarianism’s general persuasiveness, it is difficult to gauge exactly what, if anything, this perspective adds to the corporate opportunities debate. Indeed, in practice such disputes seem limited to quarrels between shareholders and corporate fiduciaries about who should capture the control rights and revenue from new business prospects. The very novelty of such projects makes it unlikely that other constituencies (e.g.,

88. See, e.g., David Millon, *Theories of the Corporation*, 1990 DUKE L.J. 201; Lawrence E. Mitchell, *A Theoretical and Practical Framework for Enforcing Corporate Constituency Statutes*, 70 TEX. L. REV. 579 (1992); Joseph William Singer, *The Reliance Interest in Property*, 40 STAN. L. REV. 611 (1988).

89. See, e.g., David Millon, *Communitarianism in Corporate Law*, in PROGRESSIVE CORPORATE LAW I (Lawrence E. Mitchell ed., 1995) (criticizing conventional contractarian accounts as being too shareholder-centric).

90. The Pennsylvania statute is prototypical. Section 515 of the Pennsylvania Consolidated Statutes states (in its relevant part):

(a) General Rule.— In discharging the duties of their respective positions, the board of directors, committees of the board and individual directors of a domestic corporation may, in considering the best interests of the corporation, consider to the extent they deem appropriate:

(1) The effects of any action upon any or all groups affected by such action, including shareholders, members, employees, suppliers, customers and creditors of the corporation, and upon communities in which offices or other establishments of the corporation are located.

15 PA. CONS. STAT. § 515 (1995).

91. David Millon has made a similar argument in greater detail, labeling such approaches as examples of “progressive contractarianism.” Millon, *supra* note 89, at 16-19.

employees, suppliers, and the like) will have a particular vested interest in the ultimate allocational decision; even to the extent that they do, it is difficult to determine exactly how. For instance, consider how employees would be affected by a substantial weakening of the COD. One could argue that moving towards a permissive rule would tend to hurt employees, since a fiduciary would now be more likely to appropriate new projects that might have represented additional hours or jobs at the firm. On the other hand, once an appropriating fiduciary has departed, she may soon begin to compete with the corporation for its own employees, a contest that could push wages upward and benefit employees as a whole. Because of the relative indeterminacy of the communitarian account in the context of the COD, I shall adhere in what follows to a more conventional contractarian view, concentrating on the optimal terms of a bilateral contract between shareholders and managers.

E. *Two Cases and a Conjecture*

I conclude this Part by comparing two well-known corporate opportunities cases: *Energy Resources Corp. v. Porter*⁹² and *Broz v. Cellular Information Systems*.⁹³ My purposes in doing so are twofold. First, the cases illustrate modern applications of the COD in a more concrete fashion. Second, and more importantly, the cases' factual premises help to animate the importance of private information in the COD context. Indeed, the two cases share a number of similar characteristics: Each applies the dominant line-of-business test to identify a corporate opportunity, and in each the defendant argued that his unilateral appropriation of a project was excused because the firm was unable to exploit the project for itself. Nevertheless, a key factual difference between the cases is the *distinct information structure* the parties faced, a distinction that I believe is critical from a contractarian perspective. This belief, in turn, motivates the central argument presented in Part III.

1. *Energy Resources Corp. v. Porter*

Energy Resources involved a breach of fiduciary duty claim brought by a fuel research corporation (Energy Resources (ERCO)) against its former vice president and chief scientist (James H. Porter). The facts of the case seem typical of a number of corporate opportunities cases.⁹⁴ Prior to his association

92. 438 N.E.2d 391 (Mass. App. Ct. 1982).

93. 673 A.2d 148 (Del. 1996), *rev'g* 663 A.2d 1180 (Del. Ch. 1995).

94. Numerous corporate opportunities decisions share similar factual premises with *Energy Resources*, particularly those in which the defendant proffered an incapacity defense based on a third party's refusal to deal. *See, e.g.,* *Regal-Beloit Corp. v. Drecol*, 955 F. Supp. 849 (N.D. Ill. 1996) (holding that a vice president and employees of a leading producer of power transmission systems and precision cutting tools usurped a corporate opportunity when they entered into an agreement to purchase a similar business, in spite of testimony that the seller distrusted and refused to deal with the plaintiff corporation); *Production Finishing Corp. v. Shields*, 405 N.W.2d 171 (Mich. Ct. App. 1986), (holding that the president of a steel polishing company usurped a corporate opportunity when he purchased a similar business from Ford Motor Co., notwithstanding testimony on Ford's refusal to deal with corporation); *Imperial Group, Inc. v. Scholnick*, 709 S.W.2d 358 (Tex. Ct. App.—Tyler 1986, writ *ref'd*

with ERCO, Porter had been on the chemical engineering faculty at MIT, researching fluidized bed combustion techniques. ERCO had commercial interests in this field, and it soon lured Porter away from the academy and into private industry. In 1977, while attending a Department of Energy conference on ERCO's behalf, Porter contacted two old acquaintances on the chemical engineering faculty at Howard University (Professors Jackson and Cannon). This interview eventually resulted in a Howard University proposal for a DOE research grant, in which ERCO was named as the principal subcontractor.

In mid-1979, according to Porter's testimony, Jackson developed reservations about the venture with ERCO.⁹⁵ He had purportedly become suspicious that ERCO was merely using the Howard University name to take advantage of federal contracting preferences. (Howard, a traditionally black institution, was supposedly in an advantageous position to receive DOE grants, which expressly favored applicants from "minority institution[s]"⁹⁶). Jackson feared that once the grant proposal was accepted, ERCO's research and development mechanism would usurp control over the project, claiming credit for the original idea. Porter testified that these concerns motivated Jackson and Cannon to suggest that Porter (who was also an African American) form his own corporation, whose name they would substitute for ERCO's in the DOE grant proposal. Porter agreed, and the defendants altered the document to delete all reference to ERCO. After submitting the proposal, but before the DOE decision, Porter continued to work at ERCO, making no mention of his pact with Cannon and Jackson. In fact, when asked about the status of the DOE proposal, Porter replied simply that "we're not going to get that."⁹⁷ Toward the end of 1979, DOE awarded a substantial grant to the Howard/Porter venture, at which time Porter immediately resigned his position at ERCO, stating that he was departing to organize a corporation that would work in the area of computerized cars.⁹⁸

During the course of the litigation, Porter proffered an "incapacity" defense, arguing that ERCO was de facto unable to take advantage of the Howard project, since Jackson and Cannon refused to deal with ERCO. Although the trial court was convinced by this argument, the Appeals Court of Massachusetts reversed, holding that in order to invoke a refusal to deal as a reason for diverting a corporate opportunity, a fiduciary must first formally disclose to the corporation both the purported refusal and a fair statement behind the reasons for that refusal.⁹⁹ Having concluded that Porter's actions fell far short of that required disclosure, the court remanded the action with an instruction to enter judgment for ERCO and to impose a constructive trust on

n.r.e.) (finding that the fiduciary of a real estate investment group usurped a corporate opportunity by purchasing for himself a specific tract of land, notwithstanding testimony that the former owner of the land would not have sold it to the group under the same terms and conditions offered to the defendant).

95. See *Energy Resources*, 438 N.E.2d at 393.

96. *Id.*

97. *Id.*

98. *See id.*

99. *See id.* at 395.

the DOE project, disgorging all profits Porter made in excess of his salary at ERCO.¹⁰⁰

2. Broz v. Cellular Information Systems

In *Broz*, a public cellular communications firm (Cellular Information Systems, Inc. (CIS)) brought a corporate opportunities claim against its former director (Robert Broz) and his wholly-owned corporation (RFB Cellular (RFBC)).¹⁰¹ RFBC, of which Broz was also president, possessed a federal cellular service license in a specific region of rural Michigan (the “Michigan 4” license). Broz simultaneously served as an outside director for CIS, which also owned and operated unrelated regional cellular networks. After a rather ambitious but unsuccessful expansion campaign, CIS became financially distressed, and, in 1992, filed for Chapter 11 reorganization. During its restructuring, CIS divested itself of all of its cellular licenses in the Midwest and agreed to restructure its existing loan obligations to impose substantial restrictions on its ability to undertake new acquisitions or incur additional debt.

In May of 1994, a third cellular provider, Mackinac Cellular (“Mackinac”) began soliciting bids for one of its rural Michigan federal licenses (the “Michigan 2” license) that bordered RFBC’s Michigan 4 area. Through its brokerage firm, Mackinac contacted RFBC and other cellular providers to solicit bids for the license. Mackinac never approached CIS, however, purportedly because it was aware of the strict financing impediments that CIS faced. Broz became interested in acquiring the Michigan 2 license, and he approached some of CIS’s directors and officers individually to inform them of his interest. In most of these casual conversations, he was informed that it was unlikely that CIS would be interested in the purchase. During the ensuing six months, RFBC (through Broz) became an active bidder in the contest for the Mackinac license.

Meanwhile, in June of 1994, most of the directors on CIS’s board (not including Broz) reached an agreement to sell their shares to yet another cellular service provider, PriCellular, if the latter were successful in making a tender offer to CIS’s public shareholders. One of the terms of the proposed acquisition was that PriCellular would assume and quickly retire CIS’s restrictive debt obligations. As it happened, PriCellular was also negotiating with Mackinac over the Michigan 2 license, and soon thereafter it procured a call option on the license at a strike price of \$6.7 million. The option, however, could be retracted by Mackinac if a competing suitor offered \$7.2 million or more before the option’s expiration date. In November of 1994, Mackinac received just such a bid from Broz, and it therefore retracted the PriCellular option, consummating a deal with RFBC. Less than two weeks

100. *See id.*

101. 673 A.2d 148 (Del. 1996), *rev’g* 663 A.2d 1180 (Del. Ch. 1995).

later, PriCellular completed its acquisition of CIS and brought an action in CIS's name against Broz for appropriating a corporate opportunity.

The Court of Chancery held for CIS, basing its opinion on two considerations in particular. First, although Broz discussed his information casually with other fiduciaries of CIS, he never formally presented the opportunity to the Board in order to procure a proper rejection. Second, it held that although CIS was unable to pursue the Michigan 2 license in its existing post-reorganization condition, Broz should have taken account of the fact that a successful acquisition of CIS by PriCellular would have once again made such a purchase both viable and likely.¹⁰²

On appeal, the Supreme Court of Delaware reversed both of the Chancery Court's findings. Chief Justice Veasey's opinion held first that formal presentation to the board is not necessary to avoid liability. Even absent such procedural formalities, the fiduciary may escape liability if, upon analyzing the situation, he determines that the opportunity is one that the corporation is incapable of pursuing.¹⁰³ Although formal presentation and rejection constitute a "safe harbor," in their absence a court must still determine ex post whether the director's judgment was erroneous.¹⁰⁴ Using this approach, the Court found that Broz reasonably determined that CIS's financing constraints precluded it from pursuing the Michigan 2 license. Second, it found that Broz was not required to take account of PriCellular's prospective interest in the license should it succeed in acquiring CIS. Holding that the prospects of the tender offer were "speculative"¹⁰⁵ at the time Broz purchased the license, the Court refused to ascribe new capacity caused by a change in control to CIS's current business prospects at the time Broz acted.

3. *Distinguishing the Cases: An Information-Based Conjecture*

Energy Resources and *Broz* make for an interesting factual and doctrinal comparison.¹⁰⁶ In both cases, the litigating jurisdiction purportedly adhered to the line-of-business test. Moreover, in each case the corporate fiduciary appealed to an "incapacity" defense to argue that the project was not within the firm's line of business, thereby hoping to absolve himself from a duty to disclose. Porter had argued that Jackson and Cannon's refusal to proceed with ERCO rendered the Howard opportunity unavailable to the corporation. Similarly, Broz had argued that CIS's financial structure had rendered the Michigan 2 acquisition unattainable as well. Nevertheless, *Energy Resources* holds that such a defense does not substitute for formal presentation to the board, while *Broz* appears to hold the opposite.

102. See *Broz*, 663 A.2d at 1186.

103. See *Broz*, 673 A.2d at 157.

104. *Id.*

105. *Id.* at 159.

106. Indeed, in a leading corporations textbook, these two cases and commentary on them constitute the COD section in its entirety. See WILLIAM A. KLEIN & J. MARK RAMSEYER, *BUSINESS ASSOCIATIONS: AGENCY, PARTNERSHIPS, AND CORPORATIONS* 334-38 (1997), 46-52 (Supp. 1998).

This observation leads one to question whether a theoretical argument exists to distinguish each respective case. I hypothesize below that the most plausible distinction (to the extent that one exists) relates to the disparate information structures confronted by both the court and the parties in each instance. Before doing so, however, I caution the reader that while this theoretical conjecture may provide a convincing means for differentiating *Energy Resources* from *Broz*, it in no way purports to be a positive “explanation” of prevailing law. On the contrary, it is the very confusion surrounding the COD that provides the motivating premise of this Article. I include this discussion of these two cases, then, not because they are representative examples of a unified doctrinal approach (for none currently exists), but rather because their distinct *factual premises* help illustrate an informational dichotomy to which courts should, as a normative matter, devote greater attention.¹⁰⁷

One possible (but rather unsatisfying) distinction between the cases is that *Energy Resources* involved a “refusal to deal” defense (which courts generally disfavor), while *Broz* involved a “financial inability” defense (to which courts tend to be more receptive).¹⁰⁸ At its core, however, this formalistic observation provides little more than a description of what courts *currently do*, rather than a prescriptive theory as to why these two types of defenses *should be* treated differently.

A second possible distinction is that the corporations in the two cases had distinct ownership structures: ERCO was a closely held corporation, while CIS was publicly traded. This observation, while true, stands at odds with conventional theories about the public-close distinction. In fact, Brudney and Clark (the principal champions of attaching legal significance to this distinction) argue that this factual difference should cut precisely the other way: Under their theory, fiduciaries of public corporations should be subjected to *more* rather than less scrutiny than their close corporation counterparts.¹⁰⁹

A third distinction hinges on the fiduciaries’ respective sources of information about the disputed project. In *Broz*, the new opportunity was presented to the defendant explicitly in his capacity as the president of an independent company: RFBC. Conversely, in *Energy Resources*, the Howard proposal came about while Porter was attending a conference at ERCO’s expense. One might assert that this factual difference would justify different outcomes, since fiduciaries who receive offers in their individual rather than

107. In fact, as I shall argue in Part IV, while the outcomes of *Energy Resources* and *Broz* might correspond with the prescriptions of the formal model, even in these cases the respective courts were perhaps too cavalier about the nuances of information structure. See *infra* text accompanying notes 189-209.

108. See *supra* text accompanying notes 33-38.

109. See Brudney & Clark, *supra* note 2, at 1006. Brudney and Clark’s distinction between close and public corporations is based, in large part, on their assessment that information asymmetries and monitoring difficulties are more prevalent for shareholders of public corporations. See *id.* at 1023. The *Broz* and *Energy Resources* opinions demonstrate that in practice, information problems need not be closely related to the ownership structure of the corporation.

corporate capacities should be given greater judicial deference. Though intuitively appealing, this argument has significant difficulties in its own right. First, there is ample evidence in *Energy Resources* that Porter's toe-hold into the Howard proposal had more to do with his personal friendship with Jackson than with his professional affiliation with ERCO.¹¹⁰ Moreover, as mentioned above, even for those opportunities in which individual capacity played a role, it is often difficult for a court (or anyone else, for that matter) to discern whether a fiduciary's personal contacts or her affiliation with the corporation was the deciding factor in attracting the disputed project.¹¹¹ Finally, even if it were possible *ex post* to deduce these respective contributions, the distinction still may not be a convincing one. For it provides no theory as to *why* parties would prefer that the fiduciary retain proprietary rights to such projects over some alternative allocation. Indeed, one could argue that the corporation "purchased" the fiduciary's individual contacts in exchange for a more lucrative up-front compensation package.¹¹²

Yet a fourth (and perhaps more plausible) candidate for distinguishing the cases is the observation that Porter was an *inside* director of ERCO while Broz was an *outside* director of CIS.¹¹³ Outsider status, one might assert, signals an implicit understanding between the parties that the corporate fiduciary should be allowed to engage in individual commercial projects. While I have no particular quarrel with this asserted distinction, I shall argue below that outsider status may be more of a symptom than it is a cause of economic circumstances that warrant greater judicial leniency.¹¹⁴

I contend that what *really* distinguishes the facts of these cases has virtually nothing to do with doctrinal categories or ownership structure and has only an indirect connection to the source of the opportunity or the fiduciary's insider/outside status. Rather, the most important difference between *Energy Resources* and *Broz* is the disparate informational structures

110. See *Energy Resources Corp. v. Porter*, 438 N.E.2d 391, 392-93 (Mass. App. Ct. 1982) (noting that Porter's initial contact with Jackson and Cannon did not stem directly from the conference he attended and that in assessing the prospects of the proposal, it was clear that "the key man was Porter" whatever his formal affiliation with the project).

111. See CLARK, *supra* note 2, at 230.

112. In fact, I shall argue that there are reasons to expect that such an arrangement is optimal in a number of situations. See *infra* note 224.

Perhaps the strongest justification for the "source" distinction is that it encourages the fiduciary to build her human capital abilities to draw in new projects. Even this distinction, however, is questionable if the fiduciary's effort tends to substitute for effort in assisting the firm in drawing in new projects. See *infra* text accompanying notes 218-221.

113. As the Delaware Court noted in *Broz v. Cellular Information Systems*: "The right of a director or officer to engage in business affairs outside of his or her fiduciary capacity would be illusory if these individuals were required to consider every potential, future occurrence in determining whether a particular business strategy would implicate fiduciary duty concerns." 673 A.2d 148, 159 (Del. 1996). The passage is beguiling in that it is used to support a judicial desideratum of "certainty" in the law. See *id.* The oddity of this passage is evident: Had the court held instead that a fiduciary was never able to take projects individually without formal rejection by the board, the resulting legal doctrine would be more, rather than less, certain.

114. See *infra* text accompanying notes 221-224. Interestingly, the insider/outside status did not appear to play a central role in either case (nor, for that matter, in the excerpt quoted *supra* note 113, which appears to apply equally to officers and to directors).

that confronted the parties and the courts in each case. In *Energy Resources*, Jackson's alleged misgivings about continuing the joint venture were clearly unobservable to ERCO and difficult, if not impossible, to verify in court ex post. Judge Kass appears to have noticed this informational asymmetry in his criticism of the trial court's verdict:

The difficulty with the [trial court's] reasoning is that the unalterability of Jackson's resolve can by no means be certain so long as Porter, by keeping Jackson's position and his reasons for it a secret, never afforded ERCO a chance to test it. Had Porter told ERCO about Howard University's desire (as manifested by Jackson) to deal with a subcontractor controlled by persons who were black, the matter might have taken a variety of turns. Other officers of ERCO might have persuaded Jackson and Cannon—or others at Howard—that the status of Porter with ERCO was such that their unease about ERCO was not warranted. It might have been possible to organize a corporation in which Porter had a majority position and ERCO had a minority position. These are but two of many possibilities.

. . . .
. . . Without full disclosure it is too difficult to verify the unwillingness to deal and too easy for the executive to induce the unwillingness.¹¹⁵

Despite this excerpt, one might even argue that Judge Kass failed to take the information problems seriously enough. For even if Porter chose to disclose Jackson's position, Porter, as the principal liaison between the parties, had a significant opportunity to distort facts to both sides so as to minimize ERCO's ability to compete effectively for the retention of the project. It would be difficult for a court sitting ex post to determine the extent and effect of such distortions. Nevertheless, it is still apparent that private information is one of the chief factors that motivated the *Energy Resources* court to prescribe a relatively broad reach for the doctrine.

In contrast to the information asymmetry of *Energy Resources*, CIS's financial constraints in *Broz* were well-publicized, not only between the fiduciary and the firm, but apparently also within the community of CIS's competitors. Moreover, these constraints (because they were a product of recorded bankruptcy proceedings) were somewhat easier to verify in court.¹¹⁶ In fact, at many junctures in the opinion, the court noted that CIS's limited ability to expand was essentially common knowledge.¹¹⁷

115. *Energy Resources*, 438 N.E.2d at 394 (footnote omitted).

116. In fact, if there were any information asymmetry in this case, it probably did not favor Mr. Broz. It was PriCellular's inside directors and officers who had the best knowledge of how likely it was that they would consummate their acquisition of CIS and choose to exercise their option on the license. See *Broz*, 673 A.2d at 153.

117. See *id.* at 151-52, 152 n.4, 155, 156, 158.

Although the informational dichotomy between *Broz* and *Energy Resources* seems evident, this observation alone falls short of providing a normative theory as to why information structure should have any legal significance. In order to provide such a theory, I must still demonstrate *why* corporations and fiduciaries would favor contractual allocations that vary across informational environments.¹¹⁸ Part III of this Article attempts to do just that, using a formal model of contracting over corporate opportunities.

III. AN OPTIMAL-CONTRACTING MODEL OF CORPORATE OPPORTUNITIES

This Part turns to the project at hand, presenting and analyzing a formal economic model of contracting over the prospective allocation of corporate opportunities. I shall use this model to demonstrate that the terms of an “optimal contract” hinge crucially on the information structure that imbues the underlying agency problem. This observation, in turn, animates the principal argument in this Article: Courts should develop and utilize a COD that likewise varies according to information structure.

Before proceeding, however, it seems appropriate to comment briefly about the general use and usefulness of economic “models.” A popular objection to the use of theoretical models is that they are unrealistic: They fail to capture the complexity and richness of detail that pervade real-world situations, thereby rendering their results untrustworthy.¹¹⁹ This criticism is, in my view, at least mildly misleading. Any model—be it economic, political, or sociological—is, by definition, a deliberate abstraction. It is designed to isolate the most intuitively compelling characteristics about a problem and to study their mutual interaction. Done thoughtfully, such an approach has considerable virtue. In particular, it facilitates deductive reasoning and precise insights, which can spawn new intuitions about the problem—intuitions that frequently elude strictly empirical or descriptive analyses. These intuitions can, in turn, play a role (though perhaps not an exclusive one) in informing subsequent policy choices.

This is not to say, however, that one should be cavalier about making assumptions. On the contrary, a well-designed model should, at the very least,

118. One need not look far into the case law to find other instances where the problems posed by an inability to verify private information have confounded courts. *See, e.g.,* *United Teachers Assocs. Ins. Co. v. MacKeen & Bailey, Inc.*, 99 F.3d 645, 652 (5th Cir. 1996) (noting that accounting for lost profits in district court involved assessing “speculative” and “exceedingly complex” testimony); *Regal-Beloit Corp. v. Drecoll*, 955 F. Supp. 849, 863 (N.D. Ill. 1996) (noting the impossibility of testing a fiduciary’s assertion that a corporation could not pursue an opportunity because of a third party’s refusal to deal without full disclosure); *Astarte, Inc. v. Pacific Indus. Sys.*, 865 F. Supp. 693, 708-09 (D. Colo. 1994) (disallowing recovery on a corporate opportunities claim because, *inter alia*, plaintiff’s damages theories were excessively speculative); *Thorpe v. CERBCO, Inc.*, 676 A.2d 436, 441, 445 (Del. 1996) (noting that damages in the case were likely speculative); *Reeves v. McReynolds*, No. 8922, 1996 Del. Ch. LEXIS 73, at *13 n.12 (Del. Ch. 1996) (noting in a corporate opportunities context that the litigants’ competing arguments about valuation techniques did little to alleviate “uncertainty” and that an appraisal proceeding would “impose additional costs and delays with an uncertain increase in accuracy”).

119. *See, e.g.,* Lynn M. LoPucki, *Strange Visions in a Strange World: A Reply to Professors Bradley and Rosenzweig*, 91 MICH. L. REV. 79, 109 (1992) (arguing that the unrealistic assumptions of perfect markets and zero transaction costs render any theory based on such assumptions “false”).

take significant care to capture the central tensions of the problem at issue.¹²⁰ Failure to do so, while not rendering the resulting theory “false,” does limit its usefulness as a practical matter. What, then, are those tensions in the corporate opportunities context? Part II suggested a number of them, but three are particularly important:

- (1) First, a corporate opportunities model should attempt to track the doctrine’s reach, which is expressly limited to corporate directors and officers. Importantly, the peculiar agency cost affecting this group appears *not* to involve conventional activities of production on the “factory floor,” but rather the macro-organizational gatekeeping functions that corporate fiduciaries share (such as screening among new potential projects for the firm).
- (2) Second, the model should permit fiduciaries to have some type of productive capacity independent of the firm’s. Indeed, the very existence of the COD seems predicated on the threat that a fiduciary might attempt to commandeer new projects for himself at the expense of corporate shareholders.
- (3) Third, the model should be sensitive to the effects of information asymmetries. In particular, it should allow for the fiduciary to possess (and attempt to profit from) private, nonverifiable information about the tendered project.

The Subsections that follow attempt to construct a model satisfying these criteria in the form of a stylized numerical example.¹²¹

A. *Framework*

Consider a risk-neutral, profit-maximizing principal, denoted by *B* (“she”), who is the residual claimant on a productive business (or “firm”).¹²² Although the firm currently engages in a number of productive endeavors, *B* stands willing to consider new business prospects as they arise. Each period, a single customer approaches the firm, offering to pay \$100 for assistance in completing some project. The population of customers is heterogeneous, however, and accordingly the *type* of project requiring completion varies from customer to customer. Some customers have projects necessitating substantial

120. Moreover, a well-designed model should clearly distinguish between *simplifying* assumptions (i.e., those that can be relaxed without altering the qualitative results) and *critical* assumptions (i.e., those that cannot).

121. The example embodies the central intuitions of a more general model of contracting contained in the Appendix.

122. Though modeled here as a unitary player, “the principal” (a.k.a. *B*) often represents an agglomeration of shareholders or some other dissipated ownership entity. Indeed, dissipated ownership is one of the principal forces behind agency problems, as the owners are ineffective monitors or information processors. This interpretation is perfectly consistent with my analysis.

technical skills (such as setting up a new computer network). Others offer projects with significant verbal requirements (such as writing advertising copy for new product lines). Still others present projects that demand a more balanced combination of skills (such as designing a new World Wide Web page dedicated to Shakespearean sonnets). To capture this notion of consumer heterogeneity, I shall use the Greek letter θ , which denotes the “type” of project (or equivalently, the type of customer) presented to the firm. In particular, θ describes the percentage composition of *verbal* (as opposed to technical) skills that the project entails. Thus, a project of type $\theta = 0$ is entirely technical in nature, while one of type $\theta = 100$ is entirely verbal; projects with intermediate values of θ entail a proportional mixture of technical and verbal requirements.¹²³ To simplify matters, I shall suppose that there are but six different types of customer who could approach the firm, each corresponding to succeeding twenty percent increments as illustrated in Table 1 below. The customer is drawn randomly from a population that has equal representation among the six project types (and thus, the ex ante probability that each customer type walks through the door during a given period is equal to $1/6$):¹²⁴

TABLE 1: THE DISTRIBUTION OF PROJECT TYPES

Project Type θ (verbal tasks as percentage of whole)	Probability of Occurrence	Technical + Verbal
$\theta = 0$	$1/6$	
$\theta = 20$	$1/6$	
$\theta = 40$	$1/6$	
$\theta = 60$	$1/6$	
$\theta = 80$	$1/6$	
$\theta = 100$	$1/6$	

123. The interpretation of θ offered in the text serves principally for explanatory ease. There are numerous alternative interpretations, depending on the application. The interpretation of θ could, for instance, correspond to the geographic location of the project, the color or size of widgets ordered, or any other source of differentiation that affects profitability. The precise interpretation of this variable is quite broad. In fact, the general framework for this model borrows from the well-known spatial competition models within industrial organization, adapting them to analyze agency problems, with demand-side rather than supply-side structural characteristics (i.e., differentiated *projects* rather than *products*). The most notable of these is the famous “linear city” model of Harold Hotelling. *See* Harold Hotelling, *Stability in Competition*, 39 *ECON. J.* 41 (1929); *see also* Steven C. Salop, *Monopolistic Competition with Outside Goods*, 10 *BELL J. ECON.* 141 (1979) (adapting the Hotelling model to other product spaces beyond geographic differentiation). The reader will note that I have portrayed consumer heterogeneity to exist along a single dimension (i.e., the relative verbal/technical mixture of tasks). In more general applications, of course, such heterogeneity might exist in multiple dimensions (such as verbal requirements and geographic locations). Although adding additional dimensions of heterogeneity is possible in this model, doing so introduces significant technical difficulties without adding any significant insights.

124. The Appendix analyzes a more general model in which the types of projects vary along a continuum and are distributed according to a commonly known distribution function $F(\theta)$.

Customer heterogeneity matters to *B* because the firm's production costs depend on the type of project offered. Suppose (for the purposes of illustration) that the principal "specializes" in completing projects that are entirely technical in nature (i.e., projects of type $\theta = 0$) and can complete those projects at a relatively low cost, which I shall assume (arbitrarily) to be \$25. Should the offered project differ from *B*'s area of expertise, she could still conceivably accept it, but only by adapting her production techniques and incurring the costs necessary to do so. Namely, it costs the principal an additional \$30 to move each twenty percent increment of adaptation from her specialty.¹²⁵ Thus, for example, to take on a project with a twenty-percent concentration of verbal tasks, *B* would bear a total cost of \$55 (i.e., \$25 in fixed costs *plus* an additional \$30 representing the cost of moving from her specialty to $\theta = 20$). Likewise, to take on a project with a forty-percent concentration of verbal skills, *B* would bear a total cost of \$85 (i.e., \$25 fixed costs plus an additional \$60 cost to move to $\theta = 40$). In mathematical terms, the principal's cost of taking on a given type of project can be summarized by the cost function $C_B(\theta) = 25 + \frac{3}{2}\theta$. This cost structure is intended to capture formally the intuition behind a firm's line of business: Although the principal operates *most profitably* when the project coincides with her area of expertise (i.e., technical projects), she can nonetheless adapt her production techniques to take on projects that are farther from her specialty—albeit at a cost that increases with the degree of adaptation required.¹²⁶

As a consequence of this cost structure, *B* is understandably interested in identifying the characteristics of the prospective project *before* she decides whether to accept it. Unfortunately, however, the principal lacks the time and/or necessary expertise to make such a determination. This dilemma is not difficult to imagine in practice, for in most practical instances, the "principal" represents *not* a unitary figure, but rather a disaggregated group of dispersed shareholders, each owning a small financial stake in the firm. With such a diffuse ownership structure, it is unlikely that any single shareholder has sufficient incentives to develop the requisite skills to screen new projects on behalf of the entire enterprise. Indeed, the costs of developing such skills would be borne privately, but the benefits would be common to all shareholders.¹²⁷

125. As with the fixed cost component, the precise value of this incremental cost is not critical to the model's ultimate results. What *is* critical, however, is the requirement that *B*'s incremental cost *increase* with the distance between her specialty and the type of project offered. This critical assumption is also made for the agent, introduced *infra* text accompanying notes 128-129.

126. The adaptation-cost version of *B*'s "line of business" is intended to reflect the intuitions underlying its doctrinal namesake as first articulated in *Guth v. Loft, Inc.*, 5 A.2d 503, 514 (Del. 1939). See *supra* note 23 and accompanying text. Notice that I assume that the firm must accommodate the customer, not vice versa. In other words, the customer has a zero "quality elasticity" of demand (i.e., she is picky). I make this assumption only for the expositional purpose of concentrating on supply-side rather than demand-side differentiation, but relaxing it has no significant qualitative effects.

127. Brudney and Clark discuss the salience of this problem particularly in publicly held firms. See Brudney & Clark, *supra* note 2, at 1023. A lack of expertise might easily exist, however, in closely held firms also. For instance, the shareholders of a close corporation may have an incentive to monitor

To address this dilemma, the principal employs a risk-neutral agent (“he”), denoted by A , to act as a liaison between potential customers and the firm. The agent might be employed in some other capacity at the firm (as with an officer or inside director), or his duties may be confined to this simple screening role (as with an outside director). While the distinction is of little moment for current purposes, suppose for concreteness that A does have other duties at the firm and that his marginal productivity in performing these tasks is valued at \$50 per period. More importantly, however, the agent is also charged with the task of receiving and evaluating each prospective customer’s project and then recommending whether the principal should pursue it. This “gatekeeping” task creates the fundamental agency cost of interest in this Article, for A possesses (much to B ’s dismay) a productive capacity of his own, which may tempt him to redirect customers to his own start-up enterprise. In particular, suppose that the agent possesses a “dormant” specialty, denoted by the Greek letter α , which need not coincide with the principal’s.¹²⁸ As with the principal, the agent can most profitably commandeer projects that coincide with his specialty, but could adapt to pursue nonconforming projects at a cost of \$30 for each twenty-percent interval he must move. Unlike the principal, however, I assume that the agent faces a larger *fixed* production cost of \$60 (rather than \$25) to take on a project that falls within his specialty. While not critical to any of the model’s results, the assumption of a higher fixed cost for the agent is intended to reflect the dual intuitions that (1) an appropriating agent is likely to face additional set-up costs that the firm has long ago sunk; and (2) the agent’s comparative advantage is in signal processing while the principal’s is in production.¹²⁹ In mathematical terms, then, if the agent were to take on a project of type θ *independently*, his production costs would be equal to $C_A(\theta) = 60 + \frac{3}{2}|\alpha - \theta|$.

more closely, but they may also possess distinct areas of expertise, making it difficult to do so. An apt example is an incorporated law firm run by two attorney/shareholders; one specializes in complex transactions and the other who specializes in First Amendment litigation. The “labor specialization” argument, therefore, need not be limited to public corporations.

128. The possibility that the agent’s specialty may be distinct from the principal’s is purposeful. Indeed, a vast number of COD cases involve fiduciaries who claim to have specialties that make the disputed project profitable to them personally, but not if buried within the internal bureaucracies of the firm. Additionally, the applicability of the COD to outside directors (who, by definition, play no productive role at the firm) further justifies this general approach. It is, of course, quite simple to alter this assumption and constrain the firm’s specialty to “track” the insider’s. Doing so, however, is simply a special case of the model posited below (a case that I call the Complete Overlap case). See *infra* Subsection III.D.3.

I also assume for now that α is exogenous. Part IV of this Article addresses the possibility that the principal may choose the agent *ex ante* from a thick market of potential agents with varying specialties.

129. Most of the results that follow hold even if the agent’s fixed production costs are equal to or even smaller than those of the principal. Nonetheless, such a variation is difficult to justify on an intuitive basis for the reasons specified in the text.

FIGURE 2. ADAPTATION COSTS FOR B AND A AS A FUNCTION OF θ ; $\alpha = 40$ 

Figure 2 depicts a geometric representation of the relationship between the project type and the players' respective costs for the particular case in which the agent's specialty (α) is equal to 40.¹³⁰ Note from the figure that production by the principal is most profitable when the project is "right up her alley" (i.e., when $\theta = 0$). For such a project, the principal's production costs are \$25, yielding a net profit of \$75. As the project's requirements grow more distant from the principal's specialty, however, retooling and adaptation costs increase accordingly. Consequently, only if the project falls within the firm's "profitable domain" (i.e., projects entailing between zero and fifty percent verbal tasks) would B have an interest in accepting the project. A similar description from Figure 2 applies to the agent. In the agent's case, however, the higher fixed cost implies that A is more constrained in adapting his specialty to take on "distant" projects profitably.¹³¹ Nonetheless, it is possible to define for the agent—just as it was for the principal—a "profitable domain" (i.e., projects falling between $13 \frac{1}{3}$ and $66 \frac{2}{3}$ percent verbal tasks) that correspond to a nonnegative net payoff for the agent.

Figure 2 illustrates merely one possible configuration, where A 's and B 's respective lines of business "partially overlap." Under this configuration, while the interests of the principal and the agent *do not always* coincide, there may be certain projects (e.g., $\theta = 20$ or $\theta = 40$) that both parties are interested in pursuing.¹³² It should be clear, however, that other qualitative configurations are possible. For example, the parties' relative specialties might be sufficiently distant so that there is "no overlap" of private interests.¹³³

130. For expositional purposes, I have chosen to fix the principal's specialty at zero and consider a number of different values for the agent's specialty, α . As we shall see, it is the *relative* (rather than absolute) positions of the parties' respective specialties that drive the results of the model, and the insights developed below apply with equal force to a more general model in which one allows both the principal's and the agent's specialties to take on differing values. For a more general approach, consult the Appendix.

131. Since the agent's specialty may be interior, he is able to adapt in either direction, whereas the principal can only adapt in one direction.

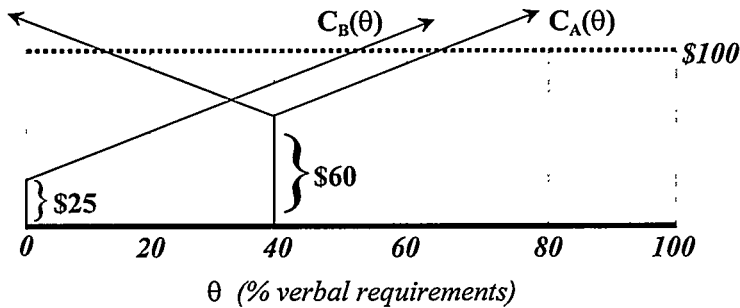
132. This Partial Overlap configuration occurs for values of α between and $23 \frac{1}{3}$ and $76 \frac{2}{3}$.

133. The No Overlap configuration occurs for values of α greater than $76 \frac{2}{3}$.

Alternatively, the parties' specialties might be sufficiently close that the principal's zone of profitability completely encompasses the agent's.¹³⁴

Finally, I shall make two additional assumptions about the agent (but not the principal) that are designed to reflect actual conditions in many labor markets. First, I will allow for *A* to be both wealth- and liquidity-constrained and therefore perhaps unable to post a sizeable performance bond *ex ante*. Indeed, were the agent not so constrained, the efficient property rights allocation would be simple, uninteresting, and unrealistic: The agent would simply "buy out" the principal, thereby eliminating the agency problem. Given that all corporate opportunities cases involve (by definition) agents who have not in fact bought out their respective principals, the possibility that the agent faces capital constraints is at least plausible.¹³⁵ Second, I assume that specific performance of the agent's contract is not feasible. If *A* so chooses, he may at any time surrender his salary, quit working at the firm, and procure a "reservation wage" from another firm equal to his current marginal product of \$50. Together, these constraints have an important theoretical significance. They suggest that in order to provide the agent with appropriate incentives (particularly when he possesses private information), the principal will have to use a larger proportion of contractual "carrots" than "sticks" relative to what she would prefer.

B. Contracting

Using the framework developed above, it is now appropriate to inquire into the nature of an "optimal" rule for allocating new corporate projects. As noted above, my analysis stays with convention in portraying the COD as a species of "contractarian" default rule,¹³⁶ intended to replicate (at least functionally) the intrafirm property rights allocation for which the corporation and the fiduciary would have bargained *ex ante* in the absence of contracting costs and bounded rationality.¹³⁷ Consequently, the remainder of this Section

134. The Complete Overlap configuration occurs when α is less than or equal to $23\frac{1}{3}$.

135. The posting of performance bonds for officers and inside directors may be further constrained by statutory authority. See *infra* note 145.

136. See, e.g., Chew, *supra* note 2, at 439; Cooter & Freedman, *supra* note 2, at 1074-75; Epstein, *supra* note 9, at 23-24. In contrast to this majoritarian view, Ian Ayres and Rob Gertner have argued that in some contracting situations, private information exists at the time of contracting, and thus contractual defaults should take into account these precontractual informational asymmetries. Their approach suggests that efficiency-minded courts should sometimes implement penalty-like default terms that are not jointly profit-maximizing, if such terms would force the parties to bargain around them in a way that induces information revelation at the time of contracting. See Ayres & Gertner, *supra* note 20, at 762-66. Interestingly, the optimal contract characterized below can (but need not) display a mixture of majoritarian and penalty-like terms. This point is spelled out more clearly in the Appendix.

137. In contrast to the canonical view of an economic actor, a "boundedly rational" person may base his decisions not on a complex, calculated, and costly-to-develop projection of how his actions will affect others, but rather on a simple and generally fallible heuristic learned through experience. See, e.g., DAVID M. KREPS, A COURSE IN MICROECONOMIC THEORY 772-73 (1990) (summarizing the literature and likening boundedly rational behavior to one's choice of strategy early in a game of chess). As applied to a contractual environment, bounded rationality may prevent the parties from predicting the emergence of some future contingency (such as the existence of a corporate opportunity), and their contract will therefore fail to specify their respective rights in such a contingency.

is devoted to characterizing the express structure of a contract that would plausibly emerge from *ex ante* bargaining.¹³⁸ Such analysis, in turn, illustrates whether and how changes in the underlying informational environment can affect the optimal legal default rule.

To make this approach more explicit, consider a contract between *A* and *B* consisting of two distinct stages. At the first stage, the agent meets with a customer (drawn randomly from the population described above), who reveals the type of project (θ) in need of completion. Upon meeting with the customer, *A* transmits a “report” back to *B* about the proposed project’s characteristics. Because *A* is a strategic profit maximizer, one cannot necessarily presume that he will tell the truth when making this report (and thus one must allow for the possibility that *A* sends a report that differs from the value of θ that he actually observes). Consequently, a critical constraint on the contracting problem (at least in the asymmetric information case) is to fashion the appropriate contractual incentives to give the agent the incentive to disclose truthfully.

The second stage of the contract dictates both the agent’s compensation and the allocation of “control” over the project based upon both *A*’s report and whatever else can be verified about the project. This stage itself consists of two parts. First, the agent receives a monetary payment from the principal, denoted by w , which one might interpret as *A*’s basic wage. In addition, the contract specifies a second term, d , that stipulates damages the agent must surrender should he decide to appropriate a given project.¹³⁹ One might

138. To be sure, this is not the only normative consideration that is conceivably at play with respect to fiduciary duties. For instance, a “social contractarian” variant of this account posits that fiduciary duties should reflect the bargain that would be made between the parties under the constraint that they bargain under fair conditions, behind a veil of ignorance as to their future identities. I hasten to note, however, that the definition of “contractarian” given in the text appears to be the dominant one in the corporations literature. See, e.g., John C. Coffee, Jr., *The Mandatory/Enabling Balance in Corporate Law: An Essay on the Judicial Role*, 89 COLUM. L. REV. 1618, 1618 (1989) (referring to contractarians as those that “see corporate law as primarily composed of waivable ‘default rules’”); Easterbrook & Fischel, *supra* note 49, at 427-29. “Communitarian” accounts of the corporation posit that the considerations underlying fiduciary duties should extend beyond the principal and agent and toward other interested constituencies, such as creditors, employees, and the broader community in which a corporation exists. My choice to concentrate on a definition of *optimality* that equates to actual bargaining outcomes stems from a number of sources. First, as noted above, that is the goal that is routinely expressed by judges in COD cases, and one aim of this Article is to illustrate how to align the doctrine more precisely with such goals. Second, because the COD is a default rule that can be changed by, say, express terms in a corporate charter, it would make little sense to articulate a doctrine that failed to correspond to plausible bargaining outcomes in the real world. Third, while one might consider making the COD an immutable rule, the voluntariness that pervades these relationships would necessitate consideration of how an immutable rule would affect decisions to contract, decisions about the appropriate form of business organization, and precontractual investment. See *supra* Subsection II.A.3.

139. The allocation terms of the contract are actually functions of the agent’s report (t) and (if verifiable) the true nature of the project (θ). The more technical model in the Appendix also considers an additional contract term to govern agents who simply refuse to disclose but instead quit their jobs and appropriate the project. While this additional term adds some insights, particularly with respect to the distinction between “majoritarian” and “penalty” default rules, I have excluded it in the text to concentrate on developing the principal intuitions of the model. Authorization is assumed to be an irreversible decision. This is typical of the factual premise in numerous cases. See, e.g., *Thorpe v. CERBCO, Inc.*, 676 A.2d 436, 437 (Del. 1996); *Energy Resources Corp. v. Porter*, 438 N.E.2d 391

interpret the d term as a type of "strike price" that A must pay if he chooses to exercise his option to appropriate. Thus, if the value of d were extremely large in magnitude, the agent would rarely (if ever) appropriate. Conversely, if the value of d were relatively small, the agent would take virtually any project he found to be profitable.

Combined, the w and d terms play two important roles for the purposes of this Article. First (and most obviously), they suggest a normative benchmark that courts might use to fill gaps within an incomplete corporate contract. Indeed, in the typical corporate opportunities case, the fiduciary and the corporation have bargained over wages (w), but have failed to provide *any* terms to govern liability for the appropriation of new projects (d). In such situations, a contractarian court must "complete" the contract by specifying damages that coincide with the optimal ex ante allocation. Thus, whenever an optimal contract specifies a $d > 0$, the court should afford the corporation a cause of action coinciding with that same level of damages. Conversely, whenever an optimal contract sets $d = 0$, the court should refuse to grant the corporation a cause of action against its fiduciary.

But secondly (and perhaps more subtly), the (w, d) combination captures both the distributional and the deterrence concerns that are central to any property rights allocation. Indeed, as just noted, the stipulated damages term (d) is an effective means by which to deter the fiduciary from taking new projects. In turn, the wage component (w) affords the parties tremendous latitude to distribute the anticipated gains from the project amongst themselves. Thus, for example, it is possible to use the two components of the contract in concert with each other to institute a "sharing" rule that induces the agent to appropriate the project, but then mandates some division of the returns from a project should the agent receive authority to take the project himself.

Given this contractual structure, it is possible to formulate a mathematical expression for the agent's payoff given a project of type θ . It has two terms. The first is simply the agent's wage, w . The second term consists of the value that the agent puts on the option of taking the project: either $\$[100 - C_A(\theta) - d]$ if appropriation remains profitable after paying damages, or $\$0$ if not. Mathematically, then, the agent's payoff (in dollars) can be expressed as:

$$\pi_A = A's \text{ Payoff} = w + \text{Max}\{0, 100 - C_A(\theta) - d\}.$$

Note from the above expression that as the damages term (d) grows increasingly large, the principal stands to disgorge a larger share of A 's *gross* profits whenever the agent appropriates. At the same time, large damages reduce the attractiveness of the project to the agent; they therefore increase the chance that A will simply choose to abstain from the given project, passing it

(Mass. App. Ct. 1982) (involving a fiduciary who wrongly substituted his own name for the corporation's on a final and unalterable proposal to the Department of Energy).

on to B .¹⁴⁰ From this observation, it is possible to describe the *principal's* payoff for a given project type. It consists of the wage (w) that is paid to the agent (which, of course, enters negatively), the \$50 in marginal productivity generated by the agent's other employment-related activities, and either (i) the damages received from the agent if A appropriates or (ii) the value of the option of taking the project herself should A be deterred. Thus, the principal's payoff (in dollars) is:

$$\pi_B = B's \text{ Payoff} = 50 - w + \begin{cases} d & \text{if } A \text{ appropriates} \\ \text{Max}\{0, 100 - C_B(\theta)\} & \text{else} \end{cases}$$

Given the payoff structure described above, the next logical step is to ask what terms (w , d) constitute an "optimal" contract between the parties. Such a determination is of paramount concern, since a contractarian court's principal aim is to replicate the allocation for which the parties, acting from the *ex ante* stage, would have bargained had they anticipated and spent the time to negotiate over corporate opportunity contingencies.

While this question seems straightforward enough to articulate, there is considerable heterogeneity within law-and-economics scholarship when it comes to defining exactly what "optimality" means. Two distinct approaches seem particularly prevalent in the corporations literature. According to one popular account, an optimal corporate contract is assumed to be the one that maximizes expected shareholder value (i.e., B 's payoff) alone, subject only to the requirement that the manager be paid enough (but only enough) to induce him to participate and behave in some desired fashion.¹⁴¹ An alternative and equally popular approach in the literature focuses on joint wealth maximization, defining an optimal contract as the one that maximizes the sum of the shareholders' *and* the manager's expected payoffs.¹⁴²

140. It is important to keep in mind that the contractual terms w and d actually denote functions $w(\theta)$ and $d(\theta)$, which may (at least in theory) vary depending on the type of project.

141. In fact, much of the economics literature now known as the "optimal contracting" approach tends to define optimality as that which maximizes the principal's payoff alone. For a recent example, see Philippe Aghion & Jean Tirole, *Formal and Real Authority in Organizations*, 105 J. POL. ECON. 1, 13 (1996). This unitary definition of optimality is now quite common within law and economics as well. See, e.g., Bebchuk & Jolls, *infra* note 188 (using a shareholder-value definition of optimality in analyzing the relative costs and benefits of permitting managers to appropriate firm value).

142. See, e.g., Cooter & Freedman, *supra* note 2, at 1064 (arguing that "[a]n important goal of fiduciary law should be to maximize the net benefits of the fiduciary relationship to its participants").

Some corporations scholars have argued that the question of "whose welfare counts" is neither important nor extremely relevant when the players are repeat actors. For example, one notable argument asserts that if courts took an extremely lax view towards the opportunistic behavior of fiduciaries, the shareholders would be able to "settle up" with the fiduciary later on, in the form of wage or other concessions. According to this argument, these projected retaliatory costs will deter a fiduciary from appropriating shareholder value when it is inefficient to do so. See EASTERBROOK & FISCHEL, *supra* note 4, at 142.

In many respects, the "ex post settling up" argument is a corporate version of the Coase Theorem, which states that in the absence of transaction costs, the underlying legal rule is irrelevant, since parties will simply bargain using side payments to an efficient allocation. But this pedigree is also its greatest weakness, for in the presence of nontrivial transaction costs (such as information asymmetries, short-term relationships, costs of reaching settling-up agreements, or impatience about the future), the *ex post*

Perhaps this heterogeneity illustrates the fact that under the right circumstances a strong case can be made for either approach. On the one hand, aggregate wealth maximization rests on strong economic foundations, for the joint wealth-maximizing contract is (by definition) the one that creates the largest total surplus available for division by the parties. Once the joint wealth-maximizing terms of contract are reached, the argument goes, the parties would be able to divide the joint gains in whatever way they see fit by using up-front side payments (such as signing bonuses or performance bonds).¹⁴³ In fact, one could argue that any other choice creates a forgone surplus that (by definition) the parties would rather jointly capture and divide.

On the other hand, it is not difficult to imagine at least some real-world situations in which aggregate wealth maximization is unlikely to result from bilateral bargaining. Of particular relevance are situations in which some of the up-front transfer payments envisioned above are simply infeasible. Consider, for instance, how the parties would negotiate if they knew that joint wealth maximization would require that the fiduciary be permitted to appropriate freely any project in which he was interested.¹⁴⁴ Is it plausible that such a permissive contract would emerge from *ex ante* bargaining between the parties? Perhaps, but if the principal has any significant bargaining power, she would likely accept this contract only if she could extract some compensatory payment (i.e., a performance bond) in advance from the agent. Unfortunately, however, such payments are not always viable, for at least two reasons. First, a number of statutes heavily restrict the contractual freedom of employers to extract performance bonds, even when the employee is a corporate fiduciary.¹⁴⁵ But moreover, even if there were no legal impediments to bonding, it seems unlikely that corporate fiduciaries would have sufficient resources to make such payments *ex ante*. Indeed, virtually *all* COD litigation would disappear if agents would simply “buy out” their respective principals, thereby eliminating conflicts of interest. That so many agents have not in fact done so may be due (at least in part) to the fact that they face binding wealth

settling up argument (like the Coase Theorem) loses much of its descriptive power, and the underlying legal rule (along with its normative premises) once again becomes important. Because this Article focuses centrally on one such cost—private information—it views the *ex post* settling up argument as having little to contribute.

143. In fact, this central intuition has the ability to transcend any number of particularized details, such as which negotiation procedure the parties employ, their relative degrees of impatience, or even the market power each player possesses. For example, even when one party commands superior bargaining power, she would be better off “cashing out” her advantage through a lump-sum payment than she would by inefficiently disadvantaging the other party through self-serving allocations. *See infra* Subsection III.D.1.

144. This hypothesis is not far-fetched. In the context of the framework developed above, consider the situation in which there is no overlap between *A*'s and *B*'s respective lines of business. Here, the joint wealth-maximizing contract would be exactly the one described in the text.

145. *See, e.g.*, CAL. LAB. CODE § 402 (West 1996) (disallowing any cash bond that exceeds the value of the property entrusted to the employee); *id.* § 404 (mandating the return of any bonded funds to the employee in excess of those necessary to “balance accounts” between the employer and employee); *id.* § 405 (regulating, through criminal sanctions, the use of funds from performance bonds by the principal); *id.* § 405 cmt. 1 (noting that the section and surrounding sections “substantially limit the right of contract” between employers and employees, but that bonding is not invalid *per se*).

and liquidity constraints—constraints that might also foreclose them from posting sizeable performance bonds.¹⁴⁶ Faced with such impediments, the principal might prefer a contract that channels her payoff through ex post allocations rather than through ex ante transfer payments from the agent. Such a contract, however, is functionally equivalent to one that assigns greater weight to the principal's payoff than it does to the agent's.¹⁴⁷

Consequently, it is probably impossible to define "optimality" in a manner that is satisfactory in all circumstances. Rather than attempting to do so, I have opted instead for a more flexible interpretation. The analysis that follows posits that an "optimal contract" consists of the contractual terms (w , d) that maximize the weighted sum of the parties' expected payoffs as viewed from the time of contracting. In mathematical terms, this definition is equivalent to the following:

$$\text{Maximize Expected Value of } \pi_A + \lambda \cdot \pi_B,$$

where λ represents the weight accorded to the agent's expected payoff relative to that of the principal. Note that this definition is sufficiently tractable to analyze either of the above conceptions of optimality: Setting $\lambda = 0$ corresponds to a definition of optimality associated with maximizing share value alone (i.e., situations in which, for liquidity or other reasons, bonding is not feasible), while setting $\lambda = 1$ corresponds to an objective of maximizing aggregate expected wealth. For purposes of greater generality, then, I will alternate in what follows between these two alternative approaches, which I shall identify (for convenience) as the "shareholder-value" and "joint-wealth" objectives, respectively.¹⁴⁸

Before proceeding further, it is interesting to note at this point that the above discussion exposes an interesting similarity between the contractarian account of fiduciary duties and the "traditionalist" approach discussed in the

146. There may be other impediments to substantial bonding as well. For instance, the posting of a bond is, in many respects, equivalent to the agent's making an undiversified investment in some measure of firm performance. Managers may resist such mechanisms for the same reason the shareholders themselves prefer to hold small stakes in the firm: diversification. Indeed, in the extreme case of a performance bond, where the agent simply buys out the firm, he is left holding an asset with a considerable amount of idiosyncratic risk—risk that he would rather diversify away.

147. To be more precise, one would expect that bargaining would produce contractual terms that implicitly accord greater weight to the shareholders' welfare (i.e., $\lambda < 1$) whenever the following combination of conditions exists:

- (a) The agent is unable to post a performance bond (for liquidity or other reasons);
- (b) The agent cannot be legally bound to work for the principal; and
- (c) The principal possesses some bargaining power relative to the agent at the ex ante stage.

A more formal demonstration of this statement appears *infra* in the Appendix.

148. In theory, of course, it is possible to specify other values of λ as well. The more general model in the Appendix permits intermediate values of λ between 0 and 1 and provides a bargaining-based interpretation for such intermediate values.

Although the chosen value of λ affects the precise terms of the optimal contract, it does not affect a fundamental qualitative argument in this Article—that in the presence of information asymmetries, the optimal doctrine is a strict liability rule with "untailored" damages that may either under- or over-deter the appropriation of new projects relative to the optimal symmetric-information rule.

previous Part.¹⁴⁹ Indeed, if one accounts for the bonding constraints, the contractarian account bears an uncanny resemblance to its traditionalist forbear: Both support a normative objective in which the fiduciary's welfare receives little or no weight relative to the corporation's (beyond, of course, that necessary to keep him from quitting). This is an important—but much-neglected—intuition in a debate that has perhaps already commanded too many pages in the legal literature.¹⁵⁰

Reiterating, then, the problem of constructing an “optimal” contract consists of designing terms w and d so as to maximize the expected value of the weighted sum of A 's and B 's private payoffs, but subject to the constraint that A 's payoff must be high enough in each state of the world to keep him from quitting.¹⁵¹ The remainder of this Part examines how the solution to this contracting problem varies as one moves between different informational structures. Section III.C analyzes the case in which the project's relevant features are easy to verify. The verifiability of the project type, as I shall show, makes it possible to tailor the contractual terms (and the damages term in particular) for each type of project, and accordingly, the optimal contract will tend to allocate authority to whomever is the lowest-cost producer. Section III.D analyzes the case in which the fiduciary privately observes the project types, and verification is impossible (or is prohibitively costly). In such a second-best world, an attempt to tailor the contract may prove counterproductive, and it becomes necessary to “incentivize” the agent's compensation package (i.e., build into the contract mechanisms that attempt to mitigate moral hazard problems), which in turn may prevent the parties from fully exploiting potential gains from trade.

C. Complete Information

Consider first the task of designing the contract described above in a world of complete information. In other words, suppose that the principal could observe, and a court could verify sufficiently, the type of project that the potential customer had offered to the fiduciary. Such information symmetry essentially renders the project type contractable,¹⁵² thereby enabling the terms of the contract to account for every possible state of the world, regardless of whether the agent discloses. It was this information structure, I contend, that characterized the facts of *Broz v. CIS*.¹⁵³ Indeed, both the existence of the

149. See *supra* text accompanying notes 74-81.

150. A noteworthy exception is Bratton, *supra* note 77, who provides a convincing account of the role that game theory might play in merging the traditionalist and contractarian accounts.

151. In addition, it will be necessary to introduce a “truth-telling constraint” for the agent when he possesses private information about θ . See *infra* Section III.D.

152. See Alan Schwartz, *Legal Contract Theories and Incomplete Contracts*, in *CONTRACT ECONOMICS* 76, 80-82 (Lars Werin & Hans Wijkander eds., 1992). Note that even if the project type were unobservable to the principal, the complete-information analysis would still be applicable if courts could costlessly verify such information *ex post*. Indeed, the parties would simply litigate each new opportunity, using the court to impose the complete-information allocation.

153. 673 A.2d 148 (Del. 1996).

Mackinac license and CIS's restrictive debt covenants were common knowledge.

Complete information is a particularly good starting point, as it is simple to analyze and renders results that corroborate one's initial intuitions. As it turns out, when information is complete, the optimal contract always allocates control over the project to whichever party is the lowest-cost producer. The intuition behind the claim is quite easy to understand. If the contract failed to allocate any given project to the lowest-cost producer, it would by definition squander a social surplus that the parties could divide between themselves, enriching both of them. Table 2 illustrates this intuition in greater detail, depicting the actual numerical terms of an optimal complete-information contract for the special case in which the fiduciary's specialty (α) is equal to 40.¹⁵⁴ The table describes the wage and stipulated damages terms that are "optimal"—in the sense of maximizing the weighted sum of the parties' individual welfare—and it illustrates the alternative cases where optimality is defined in terms of shareholder value alone ($\lambda = 0$) or in terms of joint wealth ($\lambda = 1$) to the principal.¹⁵⁵ In addition to this basic information, the table also describes—given the structure of the (w , d) terms—which party (if either) ultimately will take "control" of the project.

TABLE 2: OPTIMAL CONTRACT TERMS
UNDER COMPLETE INFORMATION; $\alpha = 40$.

		Shareholder Value Objective ($\lambda = 0$)			Joint Wealth Objective ($\lambda = 1$)		
		w	d	Control	w	d	Control
Project Type (θ)	$\theta = 0$	\$50	\$0	<i>B</i>	\$50	\$0	<i>B</i>
	$\theta = 20$	\$50	\$10.01	<i>B</i>	\$50	\$10.01	<i>B</i>
	$\theta = 40$	\$50	\$39.99	<i>A</i>	\$50	\$0	<i>A</i>
	$\theta = 60$	\$50	\$9.99	<i>A</i>	\$50	\$0	<i>A</i>
	$\theta = 80$	\$50	\$0	Neither	\$50	\$0	Neither
	$\theta = 100$	\$50	\$0	Neither	\$50	\$0	Neither

Upon inspection of Table 2, perhaps the first thing one notices is that regardless of which objective one adopts, the agent always receives a base wage equal to his marginal product of \$50. This result should not be surprising: Were the agent not promised at least this much, he would choose to find work elsewhere.

A somewhat more interesting phenomenon emerges from examining the damages component d , which constitutes the exclusive deterrence mechanism

154. The results are qualitatively identical for other values of α . The figures in the table correspond to the results presented in the Appendix.

155. Recall that from a contractarian perspective, the $\lambda = 0$ case corresponds to a situation where the agent's bonding constraints are binding, while the $\lambda = 1$ case corresponds to the opposite situation. See *supra* text accompanying note 148.

for the contract. It is through this term that the contract allocates ultimate control over the project. In order to make a first-best efficient allocation, the damages component must ensure that ultimate control flows to the most efficient producer for the disputed project. For the special case depicted in Table 2, the principal is the lowest-cost producer for project types 0 and 20,¹⁵⁶ but the agent is the lowest-cost producer for project types 40 and 60.¹⁵⁷ Moreover, neither party is an efficient producer for project types 80 and 100.¹⁵⁸ Thus, in order to exploit all possible gains from trade, a contract must create incentives that ensure that ultimate control flows in a similar direction.

Complete information is particularly advantageous here. When the state of the world is common knowledge, it becomes possible to *tailor the damages term in a manner that always ensures an efficient allocation of the project*. To see this, consider how the contract allocates control when the project type is $\theta = 20$ (a project for which the principal is the lowest-cost producer). In such a situation, as Table 2 suggests, the optimal stipulated damages term is equal to \$10.01, which is one cent higher than the \$10 in profit that the agent would gain by appropriating the project, and it thereby deters him specifically from doing so.¹⁵⁹

On the other hand, when the project type is one for which *A* is the lowest-cost producer (i.e., $\theta = 40$ or 60), the damages term is gauged so as to *preserve the agent's incentive* to appropriate the project. In particular, the damages must not overshoot the private profits that the agent would gain from appropriating (which are, respectively, \$40 and \$10). Within this range, however, preferences over distributions can play a significant role in determining the amount of wage disgorgement. Under a shareholder value objective, it is optimal to extract virtually all of the agent's private profits (so long as doing so does not deter him from appropriating efficiently). Thus, the contract calls for damages of \$39.99 when the project type is 50, and \$9.99 when the project type is 60. In either case, the agent's net gain from appropriating is positive (which preserves efficient incentives), but only leaves him with a penny of profit.¹⁶⁰

Under a joint wealth objective, by contrast, transfer payments play a neutral role in welfare considerations. Consequently, there is literally a continuum of possible damages terms that would be "optimal" in the sense

156. Note that the principal's costs of taking on project types $\theta = 0$ and $\theta = 20$ are \$25 and \$55, respectively, while the agent's analogous costs are \$120 and \$90.

157. The principal's costs of taking on project types $\theta = 40$ and $\theta = 60$ are \$85 and \$115, respectively, while the agent's analogous costs are \$60 and \$90.

158. The principal's costs of taking on project types $\theta = 80$ and $\theta = 100$ are \$145 and \$175, respectively, while the agent's analogous costs are \$120 and \$150.

159. Clearly, the \$10.01 figure is the *minimum* stipulated damages award that would deter the agent from taking the project. Any amount larger than this would serve an identical purpose.

160. The reader will note that the contract imposes no damages on an agent who takes project types 0, 80, or 100; here, the agent is already sufficiently deterred by the sheer lack of profitability of such projects. Indeed, as one can see from Figure 1, even without paying damages, a fiduciary who appropriates a project of type 0 or type 80 will incur costs of \$120, which exceed the revenues of \$100 offered by the customer. The same is true a fortiori for a fiduciary who appropriates a project of type 100, since his costs will be \$150.

defined above, as long as the agent is deterred from taking the project of type $\theta = 20$, but not deterred from taking project types 40 and 60. One such possibility is the disgorgement-like kickback described above for the $\lambda = 0$ case. A second possibility (which is reflected in Table 2) is a type of "fault" regime mandating that an appropriating agent must pay damages *only if* he appropriates a project for which the principal would have been the lowest-cost producer (i.e., $\theta = 20$).

The contractual flexibility afforded by complete information, in turn, produces perhaps the most important aspect of Table 2: The optimal contract ensures that the lowest-cost producer will always ultimately exercise "control" over the project. Indeed, as Table 2 illustrates, the principal will eventually end up with project types 0 and 20, while the agent eventually will control (perhaps after paying damages) project types 40 and 60.¹⁶¹ In fact, this "lowest-cost producer" phenomenon holds true regardless of the relative weight assigned to the fiduciary's payoff and regardless of the fiduciary's specialty. This feature should not be terribly surprising. Indeed, a failure to allocate a project to the lowest-cost producer creates by definition a surplus that is fully verifiable, and it is thereby appropriable by the parties via alternative contractual terms.

Given the structure of the complete-information contract detailed above, one might now inquire how a court might use these results to "fill the gaps" of an incomplete corporate contract. As noted above, most COD litigation arises because the parties failed to negotiate and draft clear terms governing the allocation of new projects. This failure may be the result of bounded rationality, or it may reflect a conscious attempt by the parties to conserve contracting costs and utilize the court to supply the terms of an optimal property rights allocation should such a contingency ever arise. It is in this context that the court's task becomes explicitly a constructive (rather than a solely interpretive) one.

Suppose, then, that *A* and *B* had executed a contract that stipulated nothing more than a flat wage of \$50, remaining silent as to the allocation of prospective new projects. Should a dispute over a corporate opportunity arise, a court could (and from a contractarian standpoint *should*) fill the gap by applying a legal rule that would align the parties' interests with the above-specified optimal contract. For the case illustrated in Table 2, then, a court's role consists of two important decisions. First, it should select whether to pursue a shareholder value or a joint-wealth objective (which, the reader will recall, turns on an assessment of *A*'s ex ante bonding constraints). Second, the contractarian court could invoke a doctrine that will replicate the relevant features of such an allocation as per Table 2. Thus, if $\lambda = 0$, an appropriating fiduciary would be compelled to pay damages of \$10.01 for appropriating a project of type 20, \$39.99 for appropriating a project of type 40, and \$9.99 for

161. Neither will ultimately exercise control over project types 80 and 100. This is, of course, also an efficient allocational decision, since both parties would have to pay costs in excess of revenues for such projects.

appropriating a project of type 60. Such a legal regime would look very much like a strict liability rule with (almost) perfect disgorgement of the fiduciary's gains, regardless of the corporation's actual losses.

On the other hand, under a joint-wealth objective ($\lambda = 1$), there is (as mentioned above) a continuum of different default rules consistent with optimality. The doctrine corresponding to the terms illustrated in Table 2 is a type of "fault" regime, in which the agent incurs liability (of \$10.01) whenever the court finds that the firm could have completed the project at a lower cost. This is close to the holding in *Broz*, in which the fiduciary could avoid liability by demonstrating that the corporation was unable to pursue the project itself, thereby implying that he was the lowest-cost producer.¹⁶² While I shall comment at greater length below on the implications of this section for *Broz*,¹⁶³ at this juncture I will simply note that while the opinion apparently accords roughly with a joint wealth objective, nowhere in the opinion does the court attempt to justify this decision (through an analysis of Broz's ability to bond or any other rationale).

Before proceeding to the private-information case, a few elements of this exercise warrant reiteration. First, the deterrence characteristics of the complete-information doctrine can be considered "first-best," in that the rule always channels production authority to whomever is the lowest-cost producer. This deterrence structure persists regardless of the court's choice of which objective to pursue. At the same time, however, the court's choice of objective can have a substantial effect on whether the fiduciary incurs liability for an appropriation of a new project. Under a shareholder value objective, the optimal doctrine imposes liability with near-disgorgement on the appropriation of any project from which the fiduciary might profit, regardless of the firm's interest in it. This would seem to correspond to a line-of-business test with an extremely low threshold of liability. Conversely, under a joint wealth objective, the optimal doctrine is indeterminate, but it could take the form of a rule that is fairly lax toward the agent, imposing liability only if the project is so close to the firm's specialty that the firm could perform the project more cheaply.

D. *Private Information*

Despite its accessibility and clean interpretation, the analysis thus far has shed little light on what is probably at the core of the most interesting COD cases: private information. As I noted in Part II, one frequently confronts situations (such as in *Energy Resources Corp. v. Porter*¹⁶⁴) where a fiduciary makes assertions about a disputed project that are neither observable to the

162. See *Broz v. Cellular Info. Sys.*, 673 A.2d 148 (Del. 1996). The correspondence is not perfect, for Broz had demonstrated not only that the disputed project was unambiguously outside of CIS's profitable domain, but also that he was the lowest-cost producer. Nonetheless, even this more exacting "incapacity" defense is one of the admissible legal regimes in the $\lambda = 0$ case.

163. See *infra* text accompanying notes 189-199.

164. 438 N.E.2d 391 (Mass. App. Ct. 1982).

corporation nor verifiable in court. In other situations, verification might be possible, but only through an inconvenient, time-consuming, or costly investigation.¹⁶⁵ Regardless, it would infeasible or undesirable to predicate a property-rights allocation on the parties' competing—and possibly self-serving—claims about the project.¹⁶⁶ To capture these concerns, this Subsection analyzes the contract design problem assuming that the agent's knowledge about the project type θ is unobservable to B and cannot be verified in ex post litigation. As I demonstrate below, such information asymmetries can distort significantly the characteristics of the optimal contract (and by implication the optimal legal default rule).

The most immediate and dramatic effect of private information is that it precludes the implementation of a "completely contingent" contract capable of specifying different terms for each possible state of the world. Beyond general knowledge about the population of customers, neither the principal nor a court possesses a reliable means of verifying the true state of the world. Consequently, any coherent contractual allocation can depend only on this general knowledge, along with any disclosures made by the agent.¹⁶⁷ Moreover, in evaluating the latter, one must take care to acknowledge the possibility that A may have an incentive to lie about the nature of the project in order to manipulate the ultimate allocation. The contract terms must therefore account for this possibility by providing appropriate incentives for the agent to disclose truthfully.¹⁶⁸

A related consequence of private information is that the finely-tailored damages terms that typified the perfect-information contract are now no

165. It is important to emphasize that even in situations where a court could *conceivably* verify the agent's information, it does not necessarily follow that such situations should be treated as if they were cases of perfect information. Indeed, if the total costs of verification (in particular, the parties' litigation costs) are higher than the expected benefits associated with perfect information, then it would be optimal for a court to treat the agent's information as if it were nonverifiable. Consider, for example, the case analyzed in Table 2, under a joint-wealth objective ($\lambda = 1$). In such a situation, it would be optimal to treat a case as one of "private information" whenever verification costs exceed \$1.67. See generally Schwartz, *supra* note 152, at 81 (defining verifiability as a situation in which the expected benefit of perfect information exceeds verification costs).

166. Moreover, when the parties have complete information, the underlying default rule may not be particularly relevant for efficiency purposes: If it were set incorrectly, Coasean logic suggests that the parties (each armed with complete information) would face few transaction costs in renegotiating the terms to comport with an efficient outcome. See EASTERBROOK & FISCHER, *supra* note 4, at 141. This may be particularly true in close corporations, where there are relatively few parties needed at the bargaining table.

167. I shall continue to assume, however, that the court has information about the other aspects of the problem, such as the probability distribution of projects and the respective cost structures of the principal and agent.

168. As a technical matter, I adopt a "mechanism design" approach here. Under this methodology, I attempt to characterize which, among all possible contracts that induce truth-telling and participation by the agent, is the most efficient possible allocation relative to some postulated objective (in this case, the weighted sum of the parties' expected payoffs). Using standard arguments developed in the economics literature, it is possible to concentrate solely on truth-telling mechanisms without any loss of generality. For a more detailed explanation of the "mechanism design" approach, see Eric L. Talley, *Contract Renegotiation, Mechanism Design, and the Liquidated Damages Rule*, 46 STAN. L. REV. 1195 (1994) [hereinafter Talley, *Contract Renegotiation*]; and Eric Talley, *Liability-Based Fee-Shifting Rules and Settlement Mechanisms Under Incomplete Information*, 71 CHI.-KENT L. REV. 461 (1995) [hereinafter Talley, *Fee-Shifting Rules*].

longer feasible. This point is simple to illustrate using the complete-information contract described in Table 2 above (under, say, a shareholder value objective). Suppose one were to attempt to implement this same allocation in a world of private information by simply substituting the agent's *report* about the project in place of the actual project type. According to the table, an agent who reports a project type of $\theta = 40$ would be subject to a stipulated damages payment of \$39.99 were he to appropriate it. If such an allocation mechanism were implemented in the presence of private information, it seems quite unlikely that an agent who actually confronted such a project would ever report truthfully. Indeed, the agent could (for instance) report a project type of 60 and be subjected to much more modest damages of \$9.99, thereby allowing him to capture \$30 more in profits.¹⁶⁹ (A nearly identical argument applies for the $\lambda = 1$ case as well.)¹⁷⁰ In game-theoretic terms, the contract illustrated in Table 2 is said to violate "incentive compatibility"—that is, the terms are such that the agent often has an affirmative incentive to lie in order to manipulate the ultimate decision.

It turns out that the only way to preserve incentive compatibility in the private-information case is to impose stipulated damages that are uniform across all reported project types.¹⁷¹ Indeed, were the strike price to vary from project to project, as in Table 2, *A* would have a strategic incentive to send misleading reports that coincided with the lowest possible damages. The requirement of uniform damages, however, imposes a substantial constraint on the deterrence capabilities of the contract. Recall that in the complete-information case, it was possible to deter appropriations *selectively*, calibrating the applicable damages on a project-by-project basis. With the uniform quantum of damages implied by private information, however, such targeted deterrence is no longer feasible. Now, in order to deter the appropriation of a target project, the requisite categorical damages term will *necessarily deter the appropriation of all other projects that are equally or less profitable to the agent*. This observation is important: It suggests that the optimal doctrine might not always be capable of allocating new projects to the lowest-cost producer.¹⁷²

169. There may be other misrepresentations that might put the agent in an even better position. For instance, the contract illustrated in Table 2 provides for \$0 in damages for project types 80 or 100. Under incomplete information, the agent might be able to report a project of this type and then be allowed to appropriate at no charge. Of course, *A* would then be put in the position of having to explain to *P* why he appropriated a project that neither of them supposedly found profitable, but the general problem of verification would remain.

170. Explicitly, for $\lambda = 1$, then under the "fault" regime reported in Table 2, when *A* observes a customer offering a project type $\theta = 20$, he will have an incentive to misrepresent the project type as either 40 or 60 so that he may secure authority to pursue it, garnering \$10 in profit for himself.

171. For proof of this assertion in a more general setting, see the Appendix.

172. Some scholars have categorized these two respective approaches as specific versus general deterrence. See, e.g., Jeremy Bentham, *Principles of Penal Law*, in 1 THE WORKS OF JEREMY BENTHAM 365, 396 (John Bowring ed., Edinburgh, William Tait 1843) (distinguishing "[p]articular" and "general" prevention). In terms of this debate, the introduction of private information makes general deterrence the only feasible approach to the contracting problem.

To flesh out the consequences further, the discussion below is divided into three Subsections, each addressing a different qualitative degree of “overlap” between *A*’s and *B*’s respective specialties. In all of the configurations, the object remains the same: to design contract terms w and d in a way that maximizes the weighted sum of the players’ expected payoffs, constrained by the requirements that (i) the agent’s payoff in each state of the world must be high enough to keep him from leaving the firm and (ii) any wage reduction associated with granting production authority must be uniform for all projects. After discussing all three overlap configurations, I will (in the next Part) summarize the doctrinal implications for both the complete- and incomplete-information cases.

1. *No Overlap*

Consider first the case in which the parties’ areas of expertise are so distant that no projects are simultaneously profitable to both. In the instant numerical example, the No Overlap case corresponds to situations in which *A*’s specialty (α) exceeds $76 \frac{2}{3}$. For illustrative ease, however, I shall confine attention to one such case, in which the agent specializes in projects that are 80 percent verbal. In this situation, the principal is attracted to project types 0, 20, and 40, while the agent is attracted to project types 60, 80, and 100.

As in the case of perfect information, the optimal contract rule depends on the applicable contractarian objective as depicted in Table 3 (in which the letter t is used to represent the agent’s report).¹⁷³

TABLE 3: OPTIMAL CONTRACT TERMS
UNDER ASYMMETRIC INFORMATION; $\alpha = 80$.

		Shareholder Value Objective ($\lambda = 0$)			Joint Wealth Objective ($\lambda = 1$)		
		w	d	Control	w	d	Control
Project Type (t)	$t = 0$	\$50	\$39.99	<i>B</i>	\$50	\$0	<i>B</i>
	$t = 20$	\$50	\$39.99	<i>B</i>	\$50	\$0	<i>B</i>
	$t = 40$	\$50	\$39.99	<i>B</i>	\$50	\$0	<i>B</i>
	$t = 60$	\$50	\$39.99	Neither	\$50	\$0	<i>A</i>
	$t = 80$	\$50	\$39.99	<i>A</i>	\$50	\$0	<i>A</i>
	$t = 100$	\$50	\$39.99	Neither	\$50	\$0	<i>A</i>

Under a joint wealth objective ($\lambda = 1$), the optimal contract has an exceptionally simple structure: It pays a constant wage of \$50 and imposes no damages on an agent who appropriates a new project. The structure of this contract is depicted in the right-hand portions of Table 3. Note that the agent

173. The formal demonstration of the numerical figures given in Table 3 appears in the Appendix.

assumes ultimate control over only those projects where A reports a project type that is profitable for him (i.e., 60, 80, or 100), but not profitable for the principal.¹⁷⁴ Accordingly, at least for the No Overlap case with $\lambda = 1$, the “low cost producer” rule of thumb appears to survive the introduction of asymmetric information. This result should not be terribly surprising: The No Overlap configuration signifies that A and B have complementary (rather than competing) interests. As a consequence of this complementarity, B has no strategic incentive to discourage A from taking on a project from which A could otherwise profit. By corollary reasoning, then, there is no reason for a joint-wealth-maximizing contract to deter A from taking any project in which he is interested. In fact, were the contract to exact sizable liquidated damages from the agent in the event of appropriation, the result might well be inefficient over-deterrence.¹⁷⁵

The story becomes somewhat more interesting when the contractual objective is to maximize shareholder value alone ($\lambda = 0$).¹⁷⁶ In this case, as the left-hand portion of Figure 3 illustrates (and the Appendix demonstrates), the optimal contract imposes uniform damages of \$39.99 on the agent for appropriating *any* project, regardless of its reported type. This rather large damages payment deters the agent from appropriating all but the most profitable project type. In particular, the contract deters the agent from taking control of certain “fringe” projects (i.e., types 60 and 100) that are moderately profitable to A , *even though* B is wholly uninterested in them. This restrictive feature is due to what one might call a “rent appropriation” effect: Under a shareholder-value objective, an optimal contract attempts to extract as much of the agent’s private profits as possible. Because private information implies that the damages term is uniform across all projects, however, the principal effectively must make one of two choices: Either she specifies small damages (\$9.99), which will ensure that the agent appropriates any project within his line of business, or she assesses much larger damages (\$39.99), which will deter the taking of fringe projects, but simultaneously will extract virtually all of the agent’s profit when he encounters and appropriates a project that coincides perfectly with his expertise. Choosing the higher level damages is somewhat riskier, of course, since it will “pay off” only one-sixth of the time

174. Note that this wage structure is “incentive compatible”: Because the agent’s wage is constant at \$50 regardless of his report, A has no affirmative incentive to misrepresent the project type.

175. The alert reader might notice that, for this example, it would be possible to impose a *small* wage reduction on an appropriating agent (in this case under \$10) without deterring him from appropriating any of the projects profitable to him. Although correct for this special case, this possibility is an artifact of the assumptions that (i) the population of projects is divided into six discrete types, and (ii) the agent’s specialty is evenly centered so that all three projects in his profitable domain confer strictly positive profits. The Appendix examines a more general model in which the project space is continuous (rather than discrete) and A ’s specialty is also continuous. In that case, a \$0 wage reduction is the unique optimal contract for the No Overlap case when $\lambda = 1$.

176. Recall from the previous subsection that the $\lambda = 0$ case would come about in a contractarian account when, because of credit or liquidity constraints, A is incapable of posting a performance bond that “prepays” for generous downstream benefits.

(as compared to one half for the smaller price). But here the greater payoff associated with the riskier gamble ultimately makes it worthwhile.¹⁷⁷

FIGURE 3. *B* PREFERS DAMAGES THAT OVER-DETER THE AGENT FOR “FRINGE” PROJECTS

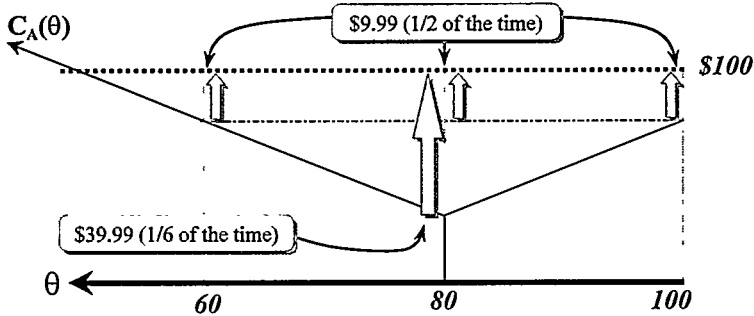

The intuition behind the rent appropriation argument is reminiscent of the classic monopoly-pricing story in economics. Much like the principal here, a monopolist has incomplete information about potential customers' precise willingness to pay. If she had such information, she would be able to “price discriminate” against each customer, charging one penny less than each customer's willingness to pay. Unfortunately, her lack of information requires her to charge a price that is uniform across customers. To maximize profits, the monopolist will continue to raise this categorical price until the profits lost from rationing out the *marginal* consumer are just equal to the benefits of extracting additional revenue from the *inframarginal* consumers who remain. Analogously, as Figure 3 illustrates, when $\lambda = 0$, the optimal contract sacrifices the production of projects lying on marginal fringes of the agent's line of business in order to extract a larger transfer payment associated with the more lucrative (albeit less frequent) project types on the interior of *A*'s profitable domain.

What do these observations imply from a doctrinal standpoint? Just as before, the default legal rule suggested by the No Overlap configuration depends first on a court's choice of contractarian objective. Under a joint-wealth objective, the above results argue against any liability whatsoever for an appropriating fiduciary. Indeed, as long as *A* can prepay for the downstream incentives he is destined to receive, it is inefficient to use a default rule that over-deters him from exploiting his interests (at no expense to the principal).

In contrast, when the fiduciary's liquidity constraints appear to be so severe that the agent cannot prepay for downstream benefits, the principal's only means of extracting her bargaining share is in the form of liability for the appropriating agent at the *ex post* stage (i.e., $\lambda = 0$). But because asymmetric

177. That is, the expected payoff from using the steep exercise price (\$6.67) exceeds the expected payoff from using the modest exercise price (\$4.99).

information requires any damages term to be *uniform*,¹⁷⁸ the principal's right of action under an optimal rule would resemble a type of strict liability claim against the agent, yielding "untailored" damages that remain constant *regardless* of the alleged project type. Moreover, this untailored amount would be large enough to deter the agent from appropriating some "fringe" projects, but still small enough to extract payments from *A* for projects that coincide more closely with the agent's expertise.

2. *Partial Overlap*

I now turn to the configuration in which the parties' specialties are close enough that their private interests sometimes—but not always—coincide. In our numerical example, Partial Overlap corresponds to situations where *A*'s specialty (α) lies between $23 \frac{1}{3}$ and $76 \frac{2}{3}$. In addition to its practical plausibility,¹⁷⁹ this configuration turns out to be the most interesting theoretically.

As before, the features of the optimal contract depend on the applicable contractual objective, which in turn depends on the court's initial assessment of the *ex ante* bonding constraints facing the fiduciary. Under a shareholder value objective ($\lambda = 0$), the form of the optimal contract is identical to that studied in the No Overlap case. In particular, it exacts fairly steep damages from the agent, thereby deterring him from appropriating any projects that lie at the fringes of his profitable domain. Just as before, such a rule tends to be over-inclusive, thereby reflecting the previously developed "rent appropriation" intuition. The contract deters the agent from taking certain fringe projects in order to extract a larger payment from him for those that are more profitable (albeit less frequent).

The more intriguing results for the Partial Overlap configuration concern the joint-wealth objective ($\lambda = 1$). These contractual terms are illustrated in Table 4, for two representative cases of agent specialty: $\alpha = 40$ and $\alpha = 60$.¹⁸⁰

178. See *supra* text accompanying notes 169-172.

179. In *Energy Resources*, for instance, Porter and ERCO had sufficiently similar specialties such that they would share a personal interest in numerous projects. Porter's defense, however, was that only he could profit from the Howard proposal. See *Energy Resources Corp. v. Porter*, 438 N.E.2d 391, 392-94 (Mass. App. Ct. 1982).

180. Once again, the results reported in this table are demonstrated more formally in the Appendix.

TABLE 4: OPTIMAL CONTRACT TERMS
UNDER ASYMMETRIC INFORMATION; $\lambda = 1$.

		Agent's Specialty (α) Is Equal to 40			Agent's Specialty (α) Is Equal to 60		
		w	d	Control	w	d	Control
Reported Project Type (t)	$t = 0$	\$50	\$39.99	B	\$50	\$9.99	B
	$t = 20$	\$50	\$39.99	B	\$50	\$9.99	B
	$t = 40$	\$50	\$39.99	A	\$50	\$9.99	A
	$t = 60$	\$50	\$39.99	Neither	\$50	\$9.99	A
	$t = 80$	\$50	\$39.99	Neither	\$50	\$9.99	A
	$t = 100$	\$50	\$39.99	Neither	\$50	\$9.99	Neither

Consider first what happens when A specializes in completing projects that are forty percent verbal. Here, as illustrated in Table 4, the optimal contract allocates control to the agent only when the reported project coincides with his specialty, but deters the appropriation of any other project. In order to enforce this allocation, of course, the contract must set sufficiently large damages (\$39.99)¹⁸¹ to prevent A from skimming off any fringe projects. This structure, in turn, implies that the optimal contract is once again over-inclusive, because it prohibits A from pursuing, say, a project type of 60 *even though the principal is wholly uninterested in such a project herself*. Unlike the previous cases, however, here such over-inclusiveness is somewhat perplexing. One cannot simply attribute it to the “rent appropriation” argument described above (in the $\lambda = 0$ case). Indeed, when the contractual objective is to maximize the *joint* welfare of the parties (i.e., $\lambda = 1$), monetary transfers from the agent to the principal should be irrelevant. Thus, some other intuition must be behind this seemingly inefficient characteristic (an intuition I shall explore below at greater length).

In an interesting contrast, consider the right-hand side of Table 4, in which the agent specializes in projects that are sixty percent verbal. Here, the optimal contract appears to be *under-inclusive* rather than over-inclusive, granting authority for A to pursue any profitable project. In order to enforce this allocation, of course, the contract must set damages that are sufficiently *low* (\$9.99 or less) to ensure that the agent is not deterred from taking any project that interests him. This implies, notably, that the agent will appropriate a project of type 40, earning a profit of \$10,¹⁸² even though the principal could

181. Given the small number of possible projects, any damages between \$10.01 and \$39.99 will have the same deterrence characteristics.

182. A 's cost of taking on a project of type $\theta = 40$ when his specialty is 60 is simply $\$60 + \frac{3}{2}(20) = \90 . Since all projects offer revenue of \$100, this implies a profit of \$10. Of course, A will have to surrender all but a penny of this profit to B , but the incentive to appropriate still exists.

have completed the same project at a \$15 profit.¹⁸³ Clearly, the optimal contract in this instance allocates control over some projects to the agent *even though the principal would be the low-cost producer*.

These last two observations are surprising indeed. By failing to allocate authority to the low-cost producer, both examples in Table 4 admit—by definition—a social inefficiency. It is precisely this type of inefficiency that joint wealth maximization attempts to avoid. Nonetheless, when one accounts for the constraints that private information imposes on the contract design process, the intuition that drives these results becomes clear.

To tease out this intuition, consider Figure 4 below, which depicts geometrically the left hand side of Table 4, where the agent specializes in projects that are forty percent verbal. In the figure, *A* is attracted to project types 20, 40, and 60, which would yield him private profits of \$10, \$40, and \$10, respectively. The principal (who specializes only in technical projects) is attracted to project types 0, 20, and 40, which would yield her private profits of \$75, \$45, and \$15, respectively. Given this structure, it appears that *B* is the lowest-cost producer for project types 0 and 20, but that *A* is the lowest-cost producer for project types 40 and 60. Thus, if it were feasible, a first-best contract would deter the agent, *A*, from taking a project of type 20, while encouraging him to appropriate project types 40 and 60.

Unfortunately, asymmetric information renders this goal unattainable. To understand why, recall that an incentive-compatible contract is constrained to impose a *uniform* strike price on an agent who appropriates a new project. A consequence of this uniformity requirement is that in order to deter the agent from taking on a given project, one must necessarily also deter him from appropriating *any other project that is equally or less profitable*. This observation immediately suggests why the optimal contract illustrated in Figure 4 must necessarily be either over- or under-inclusive. In order to deter *A* from taking a project of type 20, one must impose uniform damages of *at least* \$10. At the same time, however, in order ensure that *A* takes a project of type 60, one must set damages *below* \$10. Clearly, it is impossible to do both at once.

183. *B*'s cost of taking on a project of type $\theta = 40$ is simply $\$25 + \frac{1}{2}(40) = \85 . Since all projects offer revenue of \$100, this implies a profit of \$15.

FIGURE 4. OPTIMAL CONTRACT TRADES OFF
TWO TYPES OF INEFFICIENCY; $\lambda = 1$, $\alpha = 40$

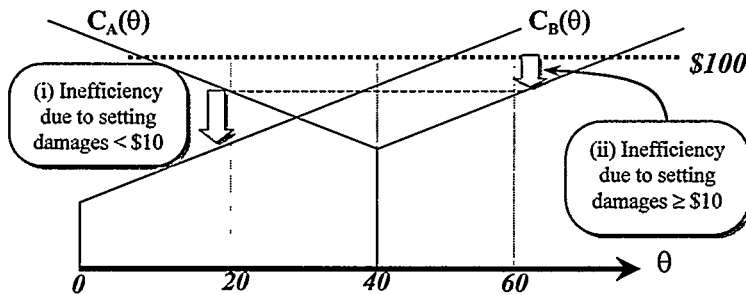

The inevitable presence of one type of inefficiency or the other implies that the optimal second-best contract ultimately must weigh (i) the cost of underdeterrence if damages are “small” against (ii) the costs of overdeterrence if damages are “large.” Herein lies the difference between the two contracts illustrated in Table 4. When $\alpha = 40$, as Figure 4 suggests, the costs of underdeterrence outweigh those of overdeterrence, and the contract optimally deters the agent from taking all but the most lucrative projects. When $\alpha = 60$, however, this trade-off cuts the other way, and the optimal contract permits the agent to appropriate projects on the fringe of his profitable domain. The inefficiency of this result is rather striking, in that it reveals an agency cost that the parties cannot eliminate through ex ante contracting, *even when* liquidity constraints do not bind the agent.¹⁸⁴

From a doctrinal perspective, the Partial Overlap configuration supports a default rule that once again has a strict liability flavor, in which the agent incurs liability for appropriating *any* project. As with the No Overlap case, the consequences for such an infraction resemble untailed liquidated damages, invariant to the fiduciary’s representations about the project’s characteristics. At the same time, however, these damages tend to be rather moderate in magnitude, balancing the inevitable costs of overdeterrence against those of underdeterrence.¹⁸⁵ Finally, note that as the parties’ respective areas of expertise converge (e.g., as one moves from $\alpha = 60$ to $\alpha = 40$), the magnitude of the damages tends to increase.

184. It is therefore somewhat more robust than the generic form of agency cost frequently studied in the literature. Cf. Sanford J. Grossman & Oliver D. Hart, *The Costs and Benefits of Ownership: A Theory of Vertical and Lateral Integration*, 94 J. POL. ECON. 691 (1986) (arguing for a model of costly contracts emphasizing specific and residual contractual rights).

185. Notice that the contract illustrated in Table 4 does not obviously support a default rule of strict liability in every possible case of Partial Overlap. In particular, when the agent’s specialty is $\alpha = 60$, it is possible to ensure appropriation of all three projects by the fiduciary without imposing any liquidated damages on the agent—the analog of a “no liability” default rule. This observation is technically correct for this particular numerical example. The broad rule of strict liability that appears in Table 4, however, is the only one that is consistent with a more general model in which the population of projects has more than six members and in fact includes a continuum of possibilities. See *infra* Appendix.

3. *Complete Overlap*

Consider finally what happens when the parties' respective specialties are so close that the principal's profitable domain completely encompasses the agent's. In this configuration, the higher fixed cost faced by the agent implies that the principal has an absolute cost advantage for every project that both parties would accept. Given the parameters of the model above, the Complete Overlap configuration corresponds to situations in which A 's specialty (α) is less than $23 \frac{1}{3}$.

This is the simplest case. Here, irrespective of the contractual objective chosen by the court, the principal's absolute cost advantage ensures that she will always be the lowest-cost producer, regardless of the project-type realization. Thus, it is optimal to deter all appropriations by A .¹⁸⁶ To accomplish this allocation through monetary means, the optimal contract must impose damages that exceed \$40, which represents the highest possible profit that the agent could procure by appropriating the project. Because the principal has an absolute cost advantage under this configuration, this prohibitory contract is also first-best efficient and therefore must have the same deterrent effects as the optimal complete-information contract for the same configuration.

The prohibitory nature of the optimal contract in the Complete Overlap case coincides most closely with a "categorical" rule against appropriations, similar to that advocated by Brudney and Clark for public corporations.¹⁸⁷ Under such a rule, all new projects are deemed to be corporate property, and appropriation by a corporate fiduciary would subject him to damages in excess of his personal gains. Alternatively (or additionally), the same type of "property right" entitlement could be created by granting the corporation an equitable right whenever feasible to enjoin the fiduciary prospectively from appropriating any new projects.

IV. DOCTRINAL IMPLICATIONS

The numerical example above, though admittedly stylized, readily illustrates the primary thesis of this Article: that information structure plays a critical role in determining intrafirm property rights over new business opportunities. In a world of perfect information, it is possible for the principal and the agent to capture and distribute all potential gains from trade, channeling production authority to whomever is the lowest-cost producer. Moreover, there appear to be a number of alternative contractual mechanisms

186. From a joint-wealth perspective, the principal is the optimal recipient of the project since she enjoys an absolute advantage over the agent. Moreover, under a shareholder-value objective, B would still rather produce, since production by the principal creates greater profits, and by owning production the principal can extract the entire surplus (even though she may not know θ) rather than monopoly price against the agent.

187. See Brudney & Clark, *supra* note 2, at 1022-45.

capable of implementing such an outcome. Private information about relevant project characteristics, however, confounds this allocative problem by introducing significant managerial incentive problems. In such a context, the optimal contract combines a generous threshold of liability with a uniform quantum of damages. Consequently, such a contract tends to induce an allocation that can be both over- and under-inclusive relative to its complete-information counterpart. This phenomenon is most pronounced in situations where the parties' respective areas of expertise partially overlap. Thus, assuming that the COD's chief normative role is to act as a contractarian gap-filling mechanism, courts would be wise also to take information structure into account when prescribing legal outcomes.¹⁸⁸

This part attempts to draw out more concretely the implications of these arguments for doctrinal reform. Perhaps the most direct way to do so is to imagine a situation (based upon the numerical example above), in which the principal and agent have entered a contract specifying wages of \$50 but have failed to provide any terms whatsoever to govern the agent's appropriation of new projects. (In the parlance of the model above, then, the parties have agreed on the w term but have omitted the d term.) The task of a contractarian court in this situation is to augment this contract with "implied" terms that replicate those the parties would have bargained for ex ante had they expressly provided for such a corporate opportunity contingencies.

188. In a paper developed independently from this one, Lucian Bebchuk and Christine Jolls argue that permitting value diversion by managers can exacerbate agency costs and may therefore not be in the best interests of the shareholders absent significant countervailing benefits. See Lucian Ayre Bebchuk & Christine Jolls, *Managerial Value Diversion and Shareholder Wealth* (February 1996) (Discussion Paper No. 179, on file with John M. Olin Center for Law, Economics, and Business, Harvard Law School). Bebchuk and Jolls demonstrate that even if one views the managerial right to divert value as an implicit form of remuneration—one that the firm can attempt to offset by reducing other forms of managerial compensation—this offsetting deduction frequently takes the form of reduced managerial participation in corporate profits, rather than a reduced salary (which already may be close to zero). See *id.* at 3-4. Such offsetting measures, however, come at a cost, for they tend to magnify the difference between the manager's and shareholders' interests, thereby increasing the manager's incentives to shirk, which in turn reduces share value even further. In fact, Bebchuk and Jolls argue, value diversion can result in a loss of shareholder welfare *even when* the manager's gains from appropriation exceed the shareholders' losses—as long as the difference between gains and losses is within a strictly positive threshold. See *id.* at 22. Moreover, they argue, in some circumstances it is *never* in the shareholders' interests to permit value diversion, no matter how large the difference between managerial gains and shareholder losses. See *id.* at 24.

My analysis differs from the Bebchuk-Jolls model in at least three respects. First, the type of agency cost they study stems from managerial "hidden action," while that analyzed here concerns managerial "hidden information" about the relative profitability of new projects. Second, most of Bebchuk and Jolls's results come from positing a contractual objective focusing on shareholder welfare alone. When, however, the fiduciary's payoff enters the contractual objective function (as this analysis permits), their results are more ambiguous. Finally and most importantly, Bebchuk and Jolls constrain their analysis to two types of contractual entitlement schemes governing managerial appropriations: (1) one that prohibits or deters all diversions by the manager; and (2) one that places no restrictions whatsoever on the manager's behavior. Their model does not consider the effects of intermediate allocations, such as a liability rule (like the one advocated here) that falls short of absolute deterrence but still compels the manager to pay damages upon appropriating. When one extends their model to permit such contractual alternatives, it is possible to demonstrate the existence of a liability rule that dominates either (1) or (2) whenever the manager's personal benefit from diversion exceeds the loss to the shareholders. Nonetheless, both my analysis and the Bebchuk-Jolls approach provide theoretical support for *some type* of legal restriction on managerial value appropriations.

Table 5 demonstrates (using the results developed in Part III) the qualitative structure of such an implied rule. The rows of the table distinguish (in the first instance) between the complete- and private-information contexts, further subdividing the latter into the three qualitative configurations of specialty overlap analyzed previously. The columns of the table distinguish, respectively, between the alternative judicial objectives of maximizing expected share value or the expected joint wealth of the participants. Finally, each cell of the table summarizes (qualitatively) the optimal doctrine that corresponds to each row-column combination, ranging from no cause of action whatsoever to categorical prohibition.

In order to implement the legal regime depicted in Table 5, then, a court must attempt to determine the applicable cell on a case-by-case basis. As to the appropriate row, the factual inquiry would center on deciding whether the litigants' competing claims about the project lend themselves to easy authentication, either by direct inspection or by reliable third-party testimony. In some instances, such as in *Broz v. CIS*,¹⁸⁹ such claims relate to a matter of public record, and verification poses little concern. In other cases, such as in *Energy Resources Corp. v. Porter*,¹⁹⁰ however, testimony may be so difficult or costly to corroborate that a court should treat the case effectively as one of private information. In this latter instance, the court must then make a determination of the degree of overlap between the parties' respective areas of expertise. Of great relevance here is whether—as a general matter—there exist at least some projects within the population of potential customers that are a relatively poor fit for the productive bureaucracy of the firm, but are well-suited to the capabilities and expertise of the fiduciary acting independently.¹⁹¹ The extent to which such projects exist is inversely related to the imputed degree of overlap in expertise; and the greater the overlap, the more onerous the resulting damages from appropriation.

Finally, a court would have to determine the applicable column from Table 5. In other words, it must decide whether to ground its decision in a shareholder-value ($\lambda = 0$) or joint-wealth ($\lambda = 1$) objective,¹⁹² and articulate its reasons for doing so. From a contractarian perspective,¹⁹³ this determination hinges on ascertaining whether, at the contracting stage, and given the parties'

189. 673 A.2d 148 (Del. 1996).

190. 438 N.E.2d 391 (Mass. App. Ct. 1982).

191. Such information might, for example, come from observing some signal of the agent's human capital skills, such as his level of education or experience. Nonetheless, one might justifiably object that in some cases, the determination of the agent's specialty might also be prohibitively costly for a court. I explicitly take up this question as an extension to the model in Part IV. It is worth noting, however, that this objection does not detract from the central thesis that "information structure" matters (and should matter) in the design of an optimal legal doctrine.

192. Although Table 5 allows for only two choices of objective, the more general analysis in the Appendix allows the court to select any value of λ between 0 and 1.

193. It bears repeating at this point that although I employ a contractarian account to animate a normative theory about the appropriate judicial objective, the doctrinal suggestions in this section may be useful even to those who do not find the contractarian account convincing. Indeed, the results summarized in Table 5 and the appendix are applicable to any normative account of the COD that lends itself to a maximand defined as some linear combination of the litigant's private payoffs. See *supra* notes 149-150 and accompanying text.

relative bargaining power and access to capital, a joint-wealth-maximizing contract would have required the agent to post a performance bond greater than his resources would allow. If so, then a shareholder-wealth objective most closely corresponds with the allocation for which the parties would likely have bargained. If, on the other hand, circumstances indicate that bonding constraints would not have circumvented a joint-wealth-maximizing allocation, then the joint objective seems more appropriate.¹⁹⁴

TABLE 5: OPTIMAL DEFAULT RULE FOR APPROPRIATING FIDUCIARY

		Shareholder-Value Objective ($\lambda = 0$)	Joint-Wealth Objective ($\lambda = 1$)
Complete Information		Strict Liability with (Approximate) Disgorgement	Indeterminate (Strict Liability or Fault Regime)
Private Information	No Overlap	Strict Liability with Liquidated Damages	No Cause of Action
	Partial Overlap	Strict Liability with Liquidated Damages	Strict Liability with Liquidated Damages
	Complete Overlap	Categorical Prohibition	Categorical Prohibition

Although this prescriptive roadmap is simple enough to describe in the abstract, perhaps a better measure of its ultimate practical utility is its application to real-world situations. The two prominent cases discussed in Part II, *Energy Resources* and *Broz*, provide an excellent vehicle for just such an endeavor. Consider first the facts of *Broz*, which appear to embody complete and symmetric information, thereby situating the case squarely in the top row of Table 5. Assuming for the moment that joint wealth maximization is the appropriate judicial objective (an assumption I shall revisit momentarily), there appears to be no unique doctrine that induces optimal productive allocations. To the contrary, any doctrine that deters the fiduciary from taking when and only when the corporation is the most profitable producer would be optimal from a joint-wealth perspective.¹⁹⁵ Nevertheless, the actual holding in the case—i.e., that Broz would incur no liability if he could demonstrate that CIS could not profit from the project¹⁹⁶—is perfectly consistent with joint

194. This determination may not always be a simple one. There are a number of possible situations, however, where concerns over bonding would not have constrained contracting. For example: (1) the fiduciary actually posted a bond; (2) the fiduciary's bargaining power was sufficiently strong that the manager would have captured most of the gains from trade; or (3) the parties are in a long-term relationship (thus allowing the agent to bond implicitly over time through wage concessions).

195. For example, one such possibility is a strict-liability doctrine in favor of the CIS, in which Broz would have to disgorge "approximately" all his profits: that is, all but a penny of his profits if he were the lower cost producer, and all of his profits plus a penny otherwise. Alternatively, joint wealth maximization would be consistent with a fault regime that allowed Broz to appropriate freely any project for which he was the lower cost producer, but enjoined him otherwise.

196. *Broz v. Cellular Info. Sys.*, 673 A.2d 148, 155 (Del. 1996).

wealth maximization. If, on the other hand, one assumes that shareholder wealth is the appropriate objective, there is only one default rule consistent with optimality: Broz would be strictly liable for any appropriation, and he must disgorge (approximately) all of his profits to CIS.¹⁹⁷

Consequently, it is possible to interpret the holding in *Broz* as consistent with an optimal default rule in Table 5, but only if Broz's ex ante bargaining power or access to capital was sufficiently abundant to justify a joint-wealth objective. If, not, then the analysis above suggests that CIS should be afforded a cause of action (with approximate disgorgement) for Broz's appropriation of any project, even if (like the Michigan 2 license) it is one that CIS could not pursue itself. It may well be the case that Broz was sufficiently liquid to post such a bond, or that his bargaining power with CIS was sufficiently strong so that he would not have to do so (or both).¹⁹⁸ In the end, then, the outcome of *Broz* is probably consistent with the model; but perhaps we shall never know with certainty, because the Delaware Supreme Court did not see fit to make the requisite inquiry. Instead, at many junctures in the opinion, the court appears simply to *assume* that a fiduciary's welfare should be accorded significant sway relative to the principals.¹⁹⁹

In contrast to *Broz*, the facts of *Energy Resources Corp. v. Porter* seem more characteristic of a private-information setting, thereby situating the case in one of the bottom three rows of Table 5. Of course, which particular row is applicable depends critically on the extent of overlap between Dr. Porter's and ERCO's respective areas of expertise. Based on the record, the degree of overlap appears to have been significant. Indeed, both Porter and ERCO

197. The disgorgement is "approximate" because the fiduciary must still be given some small incentive to appropriate when he is the most profitable producer. Were the agent forced to disgorge his exact profits, he would always be indifferent between appropriating and abstaining. It is possible to make such incentives strict without any loss of generality by allowing the fiduciary to retain an infinitesimal sum for all projects for which he is the lowest-cost producer. *See supra* note 195.

198. On the record alone, it seems almost certain that Broz had ample access to capital markets. Indeed, he was the sole owner of an already successful corporation that entered a multi-million dollar auction in competition with CIS. *See Broz*, 673 A.2d at 151-53. These facts suggest that bonding constraints were likely not a significant issue in *Broz*, which in turn implies that a joint-wealth objective would have been appropriate. Conversely, in *Energy Resources*, defendant Porter was perhaps more limited in his access to capital. Indeed, his principal source of livelihood appeared to have been his income from ERCO, and his previous income was predominantly limited to a (notoriously meager) academic salary. *See Energy Resources Corp. v. Porter*, 438 N.E.2d 391, 392 (Mass. App. Ct. 1982). These constraints suggest, in contrast, that a shareholder-value objective might have been apropos in that case.

199. Perhaps the most telling excerpt in this respect comes at the end of the opinion:

The right of a director or officer to engage in business affairs outside of his or her fiduciary capacity would be illusory if these individuals were required to consider every potential, future occurrence in determining whether a particular business strategy would implicate fiduciary duty concerns. In order for a director to engage meaningfully in business unrelated to his or her corporate role, the director must be allowed to make decisions based on the situation as it exists at the time a given opportunity is presented. Absent such a rule, the corporate fiduciary would be constrained to refrain from exploiting any opportunity for fear of liability based on the occurrence of subsequent events. This state of affairs *would unduly restrict officers and directors and would be antithetical to certainty in corporation law.*

Broz, 673 A.2d at 159 (emphasis added).

specialized in fluidized bed combustion techniques, and they likely would have competed for many of the same projects (if unaffiliated with one another).²⁰⁰ Moreover, Porter's role at ERCO was not limited to gatekeeping; he took an active role in "production" at the firm (i.e., chemical research), suggesting further that the degree of overlap was extensive. To be sure, Porter appears to have been one of the most prominent African-American researchers in his field, and it thus seems at least plausible that some potential co-venturers (such as Jackson and Cannon) might have preferred to deal with him individually rather than through ERCO.²⁰¹ But even if one finds this argument persuasive, it does not refute the general impression that the parties' respective specialties were in a state of extensive (if not complete) overlap. Consequently, as Table 5 prescribes, Porter would not be able to escape liability through unverifiable claims about ERCO's inability to pursue the Howard project. To the contrary, he would be strictly liable for appropriating the opportunity, subject either to an untailed damages remedy in the case of Partial Overlap, or to equitable relief (and perhaps even punitive damages) in the case of Complete Overlap.²⁰²

These observations suggest that the actual *Energy Resources* holding is—in many respects—consistent with the optimal default rule characterized above. Recall that Judge Kass's opinion disregarded testimony by Porter and Jackson that the Howard researchers were unwilling to pursue the DOE proposal with ERCO. Such assertions, the court reasoned, were subject to substantial manipulation and were difficult to authenticate in litigation.²⁰³ It seems reasonable to conclude, then, that the *Energy Resources* court correctly recognized both the information asymmetry and the extensive degree of overlap in expertise, and it proceeded to apply a strict liability rule like that envisioned by my analysis in the previous Section. In addition, this interpretation helps to explain what is probably the starkest doctrinal difference between *Energy Resources* and *Broz*: their apparently disparate treatments of the "incapacity defense." Instead of concluding that *Energy Resources* rejects the defense while *Broz* embraces it, this interpretation suggests that *Energy Resources* simply limits the viability of the defense to those situations in which its predicate facts are relatively easy to verify.

Nevertheless, there are at least three aspects of *Energy Resources* that are inconsistent with the model. First, the remedy that the court mandated for Porter's infraction was the imposition of a constructive trust (i.e., a

200. See *Energy Resources*, 438 N.E.2d at 392-93.

201. Indeed, as noted above, Judge Kass held that Porter's refusal-to-deal defense was subject to suspicion *not* because of its implausibility, but rather because of its nonverifiability. See *id.* at 394. As an aside, it may well be sensible to question when and whether legal rules should—as a normative matter—recognize such associational preferences, though this question is beyond the scope of the current discussion.

202. The reader should note that in the case of Complete Overlap, the court's choice of objective is irrelevant; a categorical prohibition is optimal regardless of the objective chosen. Furthermore, even in cases of Partial Overlap, the choice of objective only affects the size of the untailed damages, not the strict liability flavor of the optimal doctrine.

203. See *id.* at 394.

disgorgement remedy) on his profits.²⁰⁴ Such a remedy, however, requires that one be able to verify the fiduciary's profits. But in many private-information cases, the content of the fiduciary's proprietary knowledge may be related to some element of his realized profits, substantially confounding the feasibility of disgorgement. Second, the opinion is somewhat sanguine about the prospects that a wide net of liability will encourage future agents to disclose, thereby enabling a corporation in ERCO's position to compete on even turf for the project. Such optimism may be well-founded if the content of the fiduciary's information is fairly easy to verify once disclosed (such as, perhaps, the *existence* of a new potential project). For in such a situation, encouraging disclosure may shift the problem from one of incomplete information to one of complete information. On the other hand, one can easily imagine situations in which information asymmetries cannot be cured by a simple (but unverifiable) disclosure. In fact, Porter's position at ERCO and close friendship with Jackson suggest that this case might have been just such a situation. After all, Porter's close ties with both sides might have enabled him to disclose Jackson's reservations while still manipulating ERCO's ability to compete for the project.²⁰⁵ Thus, while my analysis is consistent with the assertion that nondisclosers deserve especially harsh treatment,²⁰⁶ the problems of private information are not always amenable to rudimentary disclosure requirements. Finally, at no time did the *Energy Resources* court attempt to determine whether a shareholder value objective or a joint wealth objective was appropriate. Because this determination may have had a profound effect on both the complete- and private-information settings, explicit attention to *ex ante* contracting constraints was probably warranted, but it was not pursued.²⁰⁷

The interdependence of information structure with specialty overlap demonstrated above suggests a substantially more subtle theoretical terrain than the conventional wisdom maintains. For example, recall that Brudney and Clark's analysis advocates, essentially on the basis of information asymmetries, a doctrine for public corporations that categorically prohibits *all* appropriations by a fiduciary.²⁰⁸ The results above suggest, however, that such a rule should apply only to those situations in which the firm's and fiduciary's "opportunity sets" completely overlap. In other configurations, where overlap

204. *See id.* at 395.

205. *See id.* at 392-93.

206. In the Appendix, I present a more general approach, in which nondisclosing appropriators are treated separately from disclosing appropriators. The results suggest an optimal doctrine that treats nondisclosers more harshly (or at least as harshly) as disclosers, as a device to "channel" agents into disclosure much as a "penalty" default rule induces information revelation. *Cf. Ayres & Gertner, supra* note 20, at 739-41 (discussing penalty defaults).

207. I hasten to add, however, that such an inquiry may not always be necessary. If, for example, one reads the *Energy Resources* opinion to have concluded that Porter's and ERCO's areas of expertise completely overlapped, then the optimal doctrine would have been a categorical prohibition regardless of the value of λ . *See supra* Table 5.

208. The primary distinction that Brudney and Clark draw between private and public corporations is the differential cost of monitoring management in the latter. *See Brudney & Clark, supra* note 2, at 1003.

is either partial or disjoint, the optimal doctrine does not have such a prohibitory flavor, and in fact it *specifically envisions* some usurpations by the fiduciary that could benefit both parties. Moreover, the distinction between my results and the Brudney-Clark proposal has readily ascertainable economic implications. In fact, it is easy to demonstrate that the optimal doctrine described above yields a shareholder payoff that is never lower and is frequently greater than that associated with absolute prohibition.²⁰⁹

Notwithstanding these observations, there are still at least two grounds upon which one might question the practical necessity and feasibility of an information-structure-specific COD. Each deserves brief attention. First, one might justifiably inquire why, if current doctrine is in need of reform, one rarely observes attempts to contract into the doctrine that I have proposed. Indeed, precisely in those circumstances where asymmetric information poses significant problems, the very inefficiency of existing doctrine would seem to provide strong incentives for the parties to contract around the COD through corporate charters or employment contracts. Consequently, in such situations one should expect to observe express terms analogous to those described in Table 5, combining (i) a sweeping definition of a "corporate opportunity" with (ii) a moderate (but not always prohibitive) liquidated damages remedy. Why, then, do we rarely see such terms in practice?²¹⁰

One should not underestimate the significance of this question. If the infrequency of such practices portends that information asymmetries are similarly rare, then the analysis from Part III has little practical value. There are, however, a number of plausible responses to this question,²¹¹ the most convincing of which emanates from the structure of corporate law itself. One would predict parties to contract for the express terms posited above *only if* courts stood willing to enforce them. Most courts, however, would likely take a dim view of a liquidated damages provision in the corporate opportunities context, surmising (correctly) that such terms tend to limit a fiduciary's

209. In situations where *A*'s and *B*'s specialties completely overlap, the optimal doctrine is a categorical rule, and thus there is no difference. In situations of Partial or No Overlap, however, the doctrine I advocate strictly outperforms a categorical prohibition. For example, in a Partial Overlap configuration in which $\alpha = 60$, a categorical prohibition would yield an expected shareholder payoff of $\$22.50 = 1/6(\$75 + \$45 + \$15)$. In contrast, the optimal private information contract described above that maximizes the principal's welfare alone ($\lambda = 0$) would yield an expected shareholder payoff of $\$29.165 = 1/6(\$75 + \$45 + \$15 + \$39.99)$. In fact, *even if* the contractual objective placed equal weight on the principal's and agent's welfare ($\lambda = 1$), the optimal contract characterized above would still outperform Brudney and Clark's, yielding a shareholder payoff of $\$24.995 = 1/6(\$75 + \$45 + \$9.99 + \$9.99 + \$9.99)$.

210. I should note that it is not particularly uncommon to observe corporate charters that expand or contract the definition of a "corporate opportunity" beyond its judicially-created proscription. Nonetheless, liquidated damages terms in the case of breach appear to be extremely rare.

211. For example (beyond the argument in the text), most parties might not be able to predict *ex ante* whether perfect or private information would obtain at a later stage. If existing doctrine were adequate for perfect-information situations, then these parties might well prefer to operate under that assumption until it became clear that there was significant private information involved, at which point they would renegotiate the contract. Viewed in this sense, the parties would in fact be implementing allocations similar to those envisioned above, but through settlement rather than *ex ante* contract provisions.

liability for breaching his duty of loyalty.²¹² As noted above, the general prohibition on damage limitations for duty-of-loyalty offenses is one of the last vestiges of corporate law that remains mandatory within most jurisdictions.²¹³ A first logical step in legal reform, therefore, might be to create a statutory “opt in” provision allowing corporate charters and/or employment contracts to stipulate damages for usurped corporate opportunities.²¹⁴

The second concern relates to feasibility. Even if one assumes that the doctrine described in Table 5 would be beneficial, its practical implementation requires a factfinder to deduce both the relative areas of expertise of the parties and some general characteristics of the customer population. Such an inquiry may be both expensive and complicated, particularly in situations like *Energy Resources*, where the litigated business activity is in a complex and technical field. One might have misgivings that these evidentiary requirements would, at least in some cases, demand too much of the judicial process. This objection is a legitimate one. Indeed, the motivating premise of this Article is that courts often find it difficult to verify the parties’ competing accounts about project characteristics. Such verification problems might easily plague other important factual determinations as well. At the same time, however, it is important to realize that this objection—plausible though it may be—is hardly a defense of current practice. To the contrary, in order to apply prevailing doctrine, a court must deduce the corporation’s area of expertise, its financial position, the exact characteristics of the project presented, the firm’s organizational adaptability, and the fiduciary’s personal gain from appropriating.²¹⁵ The argument that courts might have a difficult time implementing my proposed doctrine would seem to apply a fortiori to the existing legal regime. Viewed from this perspective, the approach in this Article represents an important first step (though perhaps a tentative one) in understanding how fiduciary law could—and should—be more sensitive to the underlying informational environment. A next logical step, then, would be to extend the model from Part III into other plausible settings. It is to that task I now turn.

V. EXTENDING THE MODEL

In this Part, I consider how several variations of the model analyzed above might alter its substantive conclusions. Such an inquiry is an important

212. Recall, as noted in the previous Part, the optimal liquidated damages remedy in the private information context would generally fall short of complete disgorgement, at least for the most profitable projects.

213. See *supra* note 20.

214. It is possible to implement this type of reform somewhat conservatively at first. For instance, an enabling provision might permit liquidated damages in corporate opportunities cases, but impose a reasonably high floor below which the stipulated amount may not fall. See, e.g., ALI PCG, *supra* note 20, § 7.19 (1992) (setting a floor equal to the fiduciary’s annual compensation in the context of damages limitations for duty-of-care violations).

215. See *supra* note 23 (describing the prevailing line-of-business doctrine for identifying a corporate opportunity); *supra* Section II.C (describing the presumptive remedy for breach).

one, particularly if one is interested in developing a more robust normative account of the relationship between information structure and legal doctrine. Because the numerical example above is deliberately stylized, there are literally an infinite number of variations that one might explore. Beyond the more generalized version of the model that appears in the Appendix,²¹⁶ however, three other variations seem particularly deserving of consideration: (a) extending the model to allow for endogeneity of the agent's specialty; (b) introducing alternative informational structures; and (c) analyzing the critical role played by judicial commitment.

A. *Endogenous Specialties*

The first variation of the model is actually more of an extension than it is a generalization. It considers the question of whom the firm will hire as a gatekeeper. Thus far, I have assumed that the principal's and agent's specialties are exogenously determined. If, however, the market for fiduciaries were a thick one, then the principal could conceivably choose from a continuum of potential agents with varying qualifications. Determining what sort of agent she selects may be of great interest to a court, particularly since the degree of overlap between the parties' specialties is a determinative factor in the structure of the optimal legal rule. Thus, holding the principal's specialty constant, what is the optimal choice of agent specialty (α)?

For the specific example studied in the previous part, the answer to this question is fairly straightforward: The firm should always attempt to hire into a No Overlap configuration. Doing so would ensure that the parties' respective incentives never conflict with one another. Consequently, the principal would be able to exploit maximally her line of business without fear of the agent's opportunistic behavior. Indeed, the agent would be happy (or at least indifferent about) disclosing projects from which the firm could profit, since those that he covets are, by definition, mutually exclusive. Thus, a No Overlap configuration would enhance the parties' joint ability to take on new projects as they see fit, allowing each to profit accordingly.

Nevertheless, in a more realistic setting there may be a number of reasons why a corporation would want to *avoid* hiring a gatekeeper whose expertise is "too distant" from its own. For instance, if there were a risk that the fiduciary would systematically tend to attract projects that were relatively close to his own individual expertise, then few profitable projects are likely to flow in the principal's direction. This reduced probability of a "hit" not only diminishes the principal's individual expected profit, but it also tends to be inefficient,

216. The Appendix analyzes a model similar to that presented in Part III. The project type is a continuous random variable, distributed according to a general distribution $F(\theta)$, and the principal's relative fixed cost component can be set at any desired amount. It also allows for an additional contract term to govern agents who appropriate without disclosing anything.

since it is the firm that presumably enjoys an overall cost advantage in production.²¹⁷

It is, however, possible to alter the model and generate examples in which the population of customers tends to “follow” the agent’s specialty in the fashion described above. Consider, for instance, a generalization of the model in which the population of customers extends along the entire real line (i.e., from $-\infty$ to ∞), and follows a normal distribution with a mean equal to the agent’s specialty (α), and a standard deviation denoted by the variable σ . In other words, a bell-shaped distribution of customers tends to shadow the agent’s specialty, but the “spread” around A ’s specialty increases as σ increases.²¹⁸

TABLE 6: SIMULATION FOR ENDOGENOUS TYPES

Standard Deviation	0	10	20	30	40	50	60	70	80	90	100	...	500
Optimal α	0	0	52	60	66	69	71	71.8	72.7	73.2	73.5	...	$\approx 76 \frac{2}{3}$

Now consider the effect of increasing the standard deviation associated with the distribution of project types, as in Table 6. When σ is “small” (less than approximately 16), customers tend to be concentrated (in a probabilistic sense) around the agent’s specialty, and Complete Overlap is the optimal joint-wealth maximizing choice for B (i.e., $\alpha = 0$). Although such a configuration forsakes any possibility of production by A , the choice is justified because the concentrated distribution ensures that virtually all project realizations will be “near” B ’s specialty, thereby enabling maximal exploitation of the principal’s comparative advantage in production. As the standard deviation increases, however, A ’s specialty becomes less decisive in determining likely project characteristics, making it more attractive for B to cast a wider collective “net” by hiring into Partial Overlap. Finally, when the standard deviation becomes so large ($\sigma \geq 500$) that the effect of the agent’s specialty on project distributions is negligible, the optimal choice of agent tends to $\alpha = 76 \frac{2}{3}$, which just satisfies the No Overlap case.²¹⁹

217. In the example from Part III, this danger did not exist, since the probability of each project type was equal to $1/6$ regardless of the agent’s area expertise.

There certainly may be other reasons why the shareholders might prefer some overlap in expertise with the fiduciary. For instance, if the fiduciary’s ability to screen projects were more precise for projects near his specialty, then a gatekeeper who was too “distant” might be prone to give erroneous advice. Or alternatively, the shareholders themselves might be in a better position to evaluate new projects that are closer to the firm’s specialty, and they therefore would be able to implement a complete-information contract if there were sufficient overlap. Both of these possibilities entail considerations similar to those articulated in the textual discussion and are therefore omitted.

218. Recall that $\alpha \leq 23 \frac{1}{3}$ constitutes Complete Overlap, while $\alpha \geq 76 \frac{2}{3}$ constitutes No Overlap.

219. It should be clear from the example that if the principal could choose the standard deviation as well as α , then she would choose $\alpha = 0$ and $\sigma = 0$; for this distribution ensures that with probability 1, the project type will coincide with the profit-maximizing location for the lowest-cost producer.

The simulation above, while by no means general, suffices to illustrate that *each* of the overlap configurations studied in the previous Part is a conceivable result of ex ante hiring decisions by a firm. Thus, the relationship between the agent's specialty and the distribution of projects may be worthy of a court's attention. Additionally, there may be a number of other indicia that an efficiency-minded court may wish to consider in determining the degree of overlap. For instance, if the fiduciary is more skilled at screening projects near his specialty than distant ones, a phenomenon nearly identical to the one illustrated above emerges: Namely, the more localized *A*'s screening ability, the greater the advantages of overlap. Alternatively, if—in addition to screening—the fiduciary plays a significant role in the firm's productive activities (as might a senior officer or inside director), then the firm's and fiduciary's respective specialties might necessarily coincide. In such a situation, significant overlap is unavoidable, and the optimal contract is more likely to stipulate either extremely large damages or a categorical prohibition.²²⁰

Although a general interpretation of these observations is impossible without a more comprehensive analysis, one might conjecture that inside directors and officers are relatively more apt to share their principals' specialties. Indeed, insiders typically have greater amounts of industry-specific expertise, which may systematically attract specific customer profiles and limit the insider's ability to screen more "distant" projects. Moreover, the productive role insiders often play at the firm seems more likely to put them in a position of significant overlap out of practical necessity. These observations support—at least as a rule of thumb—a distinction between insiders and outsiders, as do a number of jurisdictions²²¹ and the ALI's *Principles of Corporate Governance*.²²² Nonetheless, because the distinction between "employees" and "non-employees" is at best an imperfect proxy for the factors mentioned above, the agent's titular categorization alone may be only symptomatic of the underlying economic realities and therefore only marginally helpful to a court if the substantive characteristics of the agent's duties themselves are verifiable.

This exercise may suggest an empirically testable implication for hiring decisions within firms in which a substantial fraction of new business comes through personal contacts. In industries where consumers are highly responsive to the specialization and reputation of their liaison to the firm, one

One might analogize a high value of σ to the "celebrity" effect. There may be some particularly well-known agents who draw in clients of all types to the firm, regardless of whether their needs coincide with the celebrity's specialty. On the other hand, a low value of σ might correspond to a "hired gun" effect. Customers know that the agent is particularly good at one type of case (e.g., white collar defense) and tend to approach him only if their cases need such specialized services.

220. Of course, if such provisions were written into a contract, the parties might be constrained by the penalty doctrine. See Talley, *Contract Renegotiation*, *supra* note 168, at 1200-05.

221. See, e.g., *Northeast Harbor Golf Club, Inc. v. Harris*, 661 A.2d 1146 (Me. 1995) (adopting the American Law Institute's standards for corporate opportunity); *Klinicki v. Lundgren*, 695 P.2d 906, 910-21 (Or. 1985) (discussing the duties of senior executives).

222. See ALI PCG, *supra* note 20, § 5.05 (prescribing duties for directors and senior executives).

would expect signal processors to have specialties that are closely allied with the corporation's (along with more restrictions on the fiduciary's ability to appropriate customers). On the other hand, in industries where consumers are more responsive, irrespective of their particular project, to the presence of "rainmakers," an optimal contract might well attempt to avoid agency costs by avoiding overlap.

B. *Alternative Information Structures*

The theoretical model from Part III helps to demonstrate the general thesis of this Article that "information structure" matters to the design of an optimal legal rule. In particular, it illustrates the distortion of an optimal rule brought about from private information about project characteristics. While this is an important type of private, unverifiable information, it is—as noted above²²³—far from exclusive. Although space constraints preclude discussion of every permutation, one notable variation implicates situations in which the information asymmetry concerns an agent's choice of specialty rather than the project's characteristics. A potentially severe agency cost in this situation is that the agent will strategically develop a distinct expertise and then spend his time and effort attempting to attract projects that match his own specialty rather than the firm's.²²⁴

223. See *supra* text accompanying note 208.

224. There are, of course, other informational permutations. For instance, one might consider what happens to the analysis in Part III when the principal not only is unable to identify project types, but also cannot determine when the agent has actually taken the project. In particular, suppose that the principal will detect an appropriation by an agent only with some probability $\rho > 0$. How might the contractual rights and duties change to affect this difference? The theory of optimal deterrence (first articulated in similar situations within the economic analysis of torts) essentially provides the answer. In a series of well-known results going back to the work of Gary Becker, the literature suggests that when detection is imperfect, the optimal damages rule varies inversely with probability of detection. See Gary S. Becker, *Crime and Punishment: An Economic Approach*, 76 J. POL. ECON. 169, 185, 204-05 (1968). In this model, as long as A 's wealth constraint is not binding, the appropriate damages multiplier follows the so-called "rule of the reciprocal": For appropriating agents, the damages should be set to equal the applicable strike price (computed in the previous section), divided by the probability of detection, ρ . A similar conclusion was in fact reached by Cooter and Friedman, *supra* note 2, at 1061-62.

Note, however, that when the agent is liquidity-constrained (as A is here), it may be impossible to achieve the same level of deterrence as that envisioned by the optimal contract. When ρ becomes sufficiently small, the optimal "Becker" fine is so large that A 's wealth constraint will certainly bind. At that point, additional monetary sanctions are both unhelpful and unrecoverable, since A is effectively bankrupted. When this occurs, the response of the optimal contract depends on λ . If $\lambda = 1$, the contract will simply pay a supranormal wage, threatening to fire the worker whenever the agent is authorized to take the project. When $\lambda < 1$, however, the principal will settle for sub-optimal deterrence (but may invest in monitoring technology to detect appropriations). This result is similar to that first noted in Carl Shapiro & Joseph E. Stiglitz, *Equilibrium Unemployment as a Worker Discipline Device*, 74 AM. ECON. REV. 433 (1984).

Because of the liquidity problem, if the parties could contract *ex ante* for a detection probability (ρ), they would (weakly) prefer setting $\rho = 1$ (especially when A faces liquidity constraints). This observation is of particular interest because there are equivalent interpretations of ρ that touch on other doctrines. For example, the so-called "source rule" allows a corporate opportunities defendant to escape liability if he can prove that the project in question was likely to have been presented to him independent of his affiliation with the corporation. See *supra* text accompanying notes 57-59. A number of commentators have discussed the difficulty of interpreting this doctrine, particularly when both the agent's private contacts and his official position appeared to play mixed roles. But even absent these

To address this possibility, one could consider modifying the model by allowing the fiduciary to choose his specialty (α) *after* executing the contract with the principal, with the caveat that his choice be neither observable to the principal nor verifiable in court. Such an inverted sequence can prove problematic if project types tend to “follow” the agent’s choice of specialty (as was the case in the previous simulation). In such situations, one could envision that an important efficiency goal of COD would be to discourage agents from using their position at the firm for the strategic purpose of attracting new business opportunities that are appropriate only to their specialized side business.²²⁵

Such a modification is, in fact, possible. Interestingly, however, it yields an optimal contract with similar features to that characterized in Part III. In particular, the contract tends to impose liability for the appropriation of projects lying far outside the principal’s area of expertise (and, in fact, is rather vigorous in doing so). While this result appears somewhat curious at first, the strategic intuition behind it is easy to understand. The principal’s inability to monitor the agent’s choice of specialty makes it necessary to provide *A* with incentives to choose a specialty that is relatively close to *B*’s, so as to attract at least some projects that the principal finds profitable. The optimal contract creates such incentives by combining both “carrots” (i.e., allowing some appropriations) for projects that are close to the principal’s line of business, and “sticks” (i.e., large damages or prohibitions) for projects whose characteristics are more distant. For if such a distant project appeared, it would send an informative signal to the principal that *A* had probably chosen a specialty that was too distant from *B*’s. Similarly, then, an optimal default rule would tend to impose especially large sanctions on the appropriation of projects that are particularly *far* from the corporation’s expertise.

An interesting by-product of this variation to the model is that it lends further support to a suspicion first raised in Parts III and IV about the prudence of recognizing an “incapacity” defense when significant information asymmetries exist. In those earlier sections, where project types were unverifiable, a fiduciary’s assertion of corporate incapacity simply could not be verified. Here, it *would*, in fact, be possible for a court to verify that a project is not profitable to the firm (for example, a project whose type is $\theta = 100$ is assumed to be observable both to *B* and the court), but allowing the fiduciary to appropriate the project under the guise of the “incapacity defense” would create a perverse incentive structure. For if a fiduciary foresaw that a court would allow such a defense, he would have an incentive to make inefficient investments in developing his personal area of expertise and in attracting new projects.

practical concerns, my analysis suggests that if the parties were to contract over the probability (ρ) that the corporation would prevail for a project with an unclear source, they would analogously choose a fairly large value for ρ (contrary to the dictates of the source rule).

225. See, e.g., *Irving Trust Co. v. Deutsch*, 73 F.2d 121, 124 (2d Cir. 1934).

C. *The Role of Commitment*

Upon reflection, this last point raises an important “meta-thesis” that implicates many of the arguments in this Article: the critical role of dynamic commitment. Both the results from Part III and the arguments from the previous Subsection strongly suggest that in a private-information environment, the optimal second-best doctrine typically leaves money on the table *ex post*. Explicitly, it tends (sometimes) to allocate projects to the *highest* cost producer, or to prohibit the fiduciary from appropriating a project in which the principal is wholly uninterested. Such inefficiencies are often necessary to provide the agent with appropriate incentives, either to reveal the true state of the world or to make the most efficient investment choices. And herein lies the problem: Once the agent has truthfully disclosed or has chosen her expertise, everyone may realize that the applicable legal rule prescribes an inefficient or wasteful outcome.²²⁶ It is nonetheless absolutely critical that the court commit to applying the second-best doctrine in spite of this knowledge. For without such commitment, the court would undermine the very incentive structure that exists to prevent even greater efficiency losses.²²⁷

Perhaps more provocatively, even if a court were able to commit to the doctrine characterized above, the parties themselves may find it difficult to keep from renegotiating their rights in the shadow of the court’s commitment. Although the ability to renegotiate is often perceived as beneficial, in this instance the absence of a commitment by the parties not to renegotiate can similarly subvert the incentive structure that a second-best contract so carefully attempts to implement. Courts may be able to play a helpful role here, by actually making it difficult for corporations and fiduciaries to negotiate around the default doctrine *ex post*. In some sense, the dynamic commitment problem provides a rationale for treating the default rules characterized above as *immutable* once the parties commence the relationship. Doctrinally, this observation translates into a fairly restrictive posture towards “rejection” of corporate opportunities by the firm and perhaps a justification for even more onerous procedures for doing so than are currently required.²²⁸

226. For example, consider the contract described in the right-hand columns of Table 4, for the case in which the agent’s specialty is $\alpha = 60$ and the agent observes a project of type $\theta = 80$. Recall that the contract in Table 4 imposes a “flat” damages payment of \$39.99 on the disclosing agent and that this flat damages amount induces the agent to disclose truthfully. Upon the agent’s truthful disclosure, then, not only does the project type become common knowledge, but so does the fact that the damages amount will overdeter the agent from appropriating the project. It is in such situations that the parties or a court may wish to alter the terms of the optimal rule.

227. As noted above, commitment problems such as these have long been seen as problematic among economists. *See supra* note 8 and accompanying text.

228. The three conventional means by which fiduciaries may obtain corporate rejection—authorization, ratification, and “fairness”—are set out *supra* text accompanying notes 66-70. None of these tests requires a court to examine the repercussions of a settlement on the prospective *dynamic* ability to commit by either a firm or a fiduciary. In fact, the first two approaches appear to be devoted entirely to ensuring that there are procedural safeguards in place to make sure that shareholders gain something by allowing the appropriation to occur. *See id.* This is clearly insufficient to address the dynamic concerns voiced above, since the “dangerous” type of renegotiation is *precisely* the kind that involves an *ex post* gain by both parties. The rather vague “fairness to the corporation” test is the only

VI. CONCLUSION

Since its inception over a century ago, the COD has never been a paragon of analytical precision. This has not been, however, from a lack of effort. Talented judges, legislators, and legal academics have all, at one time or another, made valiant attempts to simplify and clarify the law, but a unified normative account of the COD has thus far proven to be frustratingly elusive. This Article has argued that perhaps some of this confusion stems from the need to regulate a vast number of heterogeneous informational environments. In particular, I have applied a methodology from information economics to demonstrate how an optimal doctrine changes dramatically when one moves from a world of complete information to one in which corporate fiduciaries possess private, unverifiable knowledge about the nature of new projects. Such an approach can yield novel intuitions about an extremely old and intractable problem. For example, private information suggests a doctrine that combines a generous domain of liability with an “untailed” remedy resembling liquidated damages: a rule that tends to be over-inclusive relative to its perfect-information counterpart, and it may (in some situations) be under-inclusive as well.

Jointly, these observations suggest a number of potential directions for doctrinal reform. At an abstract level, they imply that instead of prolonging the quixotic pursuit of a unitary, unqualified doctrine, efficiency-minded courts should begin to pay substantially greater attention to information structure than is currently the norm. In situations where the litigants’ claims are difficult to corroborate, courts should abandon doctrinal tests that require them to adjudicate the unverifiable. They should instead develop alternative (albeit imperfect) doctrines that concentrate on more provable indicia.²²⁹ Thus, for example, in some situations, courts might wish to disregard altogether the litigants’ competing claims about the nature of a disputed project, and focus instead on the degree of overlap between the parties’ respective areas of expertise.

With respect to doctrinal specifics, my analysis presents a mixed bag. On the one hand, it contrasts significantly with some elements of current practice. Most obviously, in cases of private information, my proposed rule would proscribe activities that lie far outside the current judicial conception of a corporation’s line of business. Consequently, it would not permit corporate fiduciaries to escape liability by asserting that the corporation was in some

one that comes close to resembling a substantive assessment. But even here, most authority suggests that the judicial ascertainment-of-fairness test should use a static, rather than a dynamic, timeframe. *See, e.g.*, ALI PCG, *supra* note 20, § 5.02(a)(2)(A) (noting that the fiduciary may escape liability for control transactions when “[t]he transaction is fair to the corporation *when entered into*” (emphasis added)).

229. In fact, it may sometimes be prudent for courts to disregard not only unverifiable claims, but also certain verifiable ones. *See, e.g.*, B. Douglas Bernheim & Michael D. Whinston, *Incomplete Contracts and Strategic Ambiguity*, 88 AM. ECON. REV. 902, 902-04 (reviewing the literature and arguing that a danger in contracting over too many aspects of verifiable performance is that it may further distort an agent’s incentives regarding unverifiable actions).

way “incapacitated” from taking on the disputed project. Furthermore, the untailored quantum of damages suggested by my results contrasts starkly with current doctrine (which mandates complete disgorgement in all cases), some mandatory corporate laws (which prohibit a priori stipulation or limitation of damages for breach of loyalty), and popular reform proposals (such as immutable and categorical prohibition). On the other hand, my results tend to corroborate many other doctrinal conventions. For instance, to the extent that ownership structure is an indirect proxy for information structure, legal distinctions between public and close corporations appear to be justified. The results of the model are also consistent with the distinction between outside directors and inside directors/officers, once again to the extent that titular status is a symptom of deeper information problems or overlapping expertise.

In addition to its principal thesis, my analysis sheds some light more generally on two important but oft-neglected caveats to the contractarian approach. First, the very *definition* of an appropriate contractarian objective may hinge on the ex ante bargaining and capital constraints that confront contracting parties. When these constraints appear to be significant (particularly in contexts of private information), the enterprise of reconstructing a hypothetical bargain need not coincide with joint wealth maximization. Rather, in such situations, a contractarian objective may coincide more closely with maximizing shareholder value alone. Second, my results expose a tension that often exists between *static* and *dynamic* normative concerns. In order to create appropriate incentives, rules that are efficient ex ante frequently create allocations that may appear to be improvident or wasteful in hindsight. When confronted with such situations, courts should not only resist the temptation to tinker with these allocations, but they can also sometimes assist the parties, ironically enough, by making it difficult to renegotiate their respective rights once a dispute arises.

The application of information economics to law has, in recent years, become a remarkably fertile area of research. This trend seems particularly salient within corporations law, where the nexus-of-contracts description of the firm is now the dominant analytic framework for both positive and normative theory. With my efforts here, I have endeavored to contribute to that enterprise, taking aim at a branch of fiduciary law that has long been fraught with profound confusion and disagreement. The intuitions developed above are an important first step in developing a more coherent account of fiduciary duties. Moreover, they expose a significant legal reform opportunity—one whose knock we would be wise to answer.

APPENDIX

This Appendix presents a general model upon which the example in Part III is based.

A. Framework.

Consider a framework similar to that described in the text, but one that entails continuous (rather than discrete) project types. The relevant variables are defined as follows:

$B \equiv$ Principal;

$A \equiv$ Agent;

$\theta \equiv$ customer/project type, where $\theta \in \Theta \equiv [\underline{\theta}, \bar{\theta}] \subseteq \mathbb{R}$

(I assume θ is distributed according to a commonly-known cumulative distribution function $F(\theta)$, that $F(\cdot)$ is differentiable everywhere on Θ , and that $F'(\theta) \equiv f(\theta) > 0$ for all $\theta \in \Theta$)²³⁰;

$V \equiv$ Revenue from the project

(normalized without loss of generality so that $E[V] = 1$);

$\beta \in \Theta \equiv$ Principal's specialty;

$\alpha \in \Theta \equiv$ Agent's specialty

(I assume without loss of generality that $\alpha \geq \beta$)²³¹

$C_A(\theta) = c_A + |\alpha - \theta| \equiv A$'s incremental cost of completing project type θ , where $c_A \in [0, 1)$ denotes a fixed cost component;

$C_B(\theta) = |\beta - \theta| \equiv B$'s incremental cost of completing project type θ ;

$\underline{\mu} \equiv$ Agent's marginal product outside of his gatekeeping duties (assume for simplicity that this is also A 's reservation wage).

FIGURE A1: RELATIONSHIP BETWEEN PROJECT TYPE AND PLAYER SPECIALTY

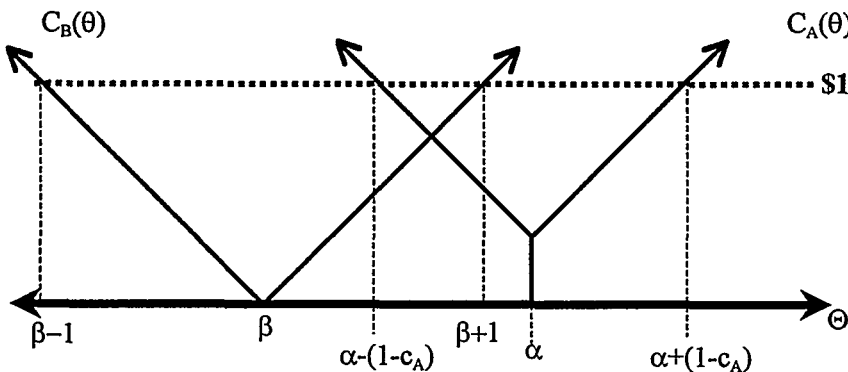

230. Relaxing this assumption is possible, but doing so provides no added insights.

231. The analysis is symmetric when $\alpha \leq \beta$.

Figure A1 illustrates the structure of the relationship between the project type and the players' respective specialties. As with Figure 2 in Part III, production by the principal is most profitable when $\theta = \beta$. For such a project, the principal's cost of production is zero, and her expected profits are $E[V] = \$1$. As the project type grows more distant from the principal's specialty, retooling and adaptation costs increase as well. Consequently, only if θ were within a well-specified "profitable domain" (i.e., $\theta \in [\beta-1, \beta+1]$) would the principal be interested in accepting the project.

A similar analysis applies to the agent. In A 's case, however, the additive cost component c_A signifies that net profits for the agent are less than 1, even when $\theta = \alpha$. Nonetheless, since $c_A < 1$, it is possible to define for the agent—just as it was for the principal—a profitable domain (i.e., $\theta \in [\alpha-(1-c_A), \alpha+(1-c_A)]$) reflecting project types for which the agent could earn a nonnegative expected gross profit.

B. Contracting

For the sake of technical clarity, I shall analyze a somewhat different contract from the one discussed in the text. The contract consists of three principal components: The first is an "authorization" component, $p(\theta)$, specifying the probability that a disclosing agent receives authorization to pursue individually a project of type θ . (Authorization is assumed to be an irreversible decision.) The second is a "wage" component, $w(\theta)$, specifying a monetary transfer from the principal to the disclosing agent for project type θ . Finally, should the agent decide that instead of disclosing, he would rather quit his job *and* appropriate the project for himself, the contract provides for a damages term, $D(\theta)$, payable by the agent to the principal.

Note that the authorization and wage components capture the two fundamental economic features of a property-rights allocation: The $p(\theta)$ component captures the productive decision of *who engages in production*; and the $w(\theta)$ term captures the distributional decision of *how to divide the spoils*. Thus, the disclosure terms $p(\theta)$ and $w(\theta)$ are broad enough to permit a "sharing" component that would, say, mandate division of the returns from a project should the agent receive production authorization. Such a term would appear implicitly through the $w(\theta)$ component.²³²

The damages term $D(\theta)$ specifies what happens to the "nondisclosing appropriator"—i.e., the agent who, after learning θ but before disclosing to the principal, B , decides to quit the firm and appropriate the project for himself. (The possibility of a nondisclosing participant was suppressed in the text, but I analyze it for completeness here.²³³) In what follows, I shall make use of the

232. Note the distinction from the model articulated in the text, which used a wage and liquidated damages term to effect substantially the same allocation.

233. More explicitly, the reader should take care not to confuse the liquidated damages term in the textual example (i.e., " d ") with the damages term governing nondisclosing appropriators (i.e., $D(\theta)$). In the textual analysis, the only way the agent could appropriate the project was by participation and then disclosure. The counterpart to the damages term from the text is implicit in the wage function in the current analysis. See *supra* note 232.

“revelation principle,” which allows one to confine attention to contracts that induce participation and truth-telling by the agent in all states of the world. Consequently, nonparticipation is never part of equilibrium behavior under an optimal contract. Nonetheless, $D(\theta)$ plays a fundamental role in shaping the wage and authorization terms, since it affects the credibility of the agent’s “threat” to opt out of the disclosure mechanism. Note also that $D(\theta)$, while specified as a type of “liability rule,” is also more general than it may first appear. If $D(\theta)$ were sufficiently large, the nonparticipating agent would never choose to appropriate upon quitting, and the liability rule would become the strategic equivalent of a property rule (i.e., injunctive relief) benefiting the principal. Conversely, if $D(\theta)$ were equal to 0, then a nonparticipating agent would always appropriate the project whenever his independent profits were nonnegative, thereby replicating the strategic equivalent of a pro-agent property rule. In general, should the agent elect nonparticipation, he will receive a reservation payoff of $\mu(\theta; D(\theta)) = \underline{\mu} + \text{Max}\{0, 1 - C_A(\theta) - D(\theta)\}$.

Under this structure, the expected payoff to the participating agent, A , when θ is the current state of the world is as follows:

$$\pi_A(p(\theta), w(\theta), \theta) = p(\theta) \cdot \text{Max}\{0, 1 - C_A(\theta)\} + w(\theta). \quad (1)$$

Similarly, the expected payoff to the principal, B , when the agent participates and θ is the current state of the world, is as follows:

$$\pi_B(p(\theta), w(\theta), \theta) = (1 - p(\theta)) \cdot \text{Max}\{0, 1 - C_B(\theta)\} - w(\theta) + \underline{\mu}. \quad (2)$$

In order to formulate a meaningful concept of “optimality,” it is critical to define a maximand. For the analysis that follows, I define an objective function comprising the weighted sum of the parties’ ex ante expected wealth. Denoting $\Psi(p(\theta), w(\theta); \lambda)$ to represent this sum, the maximand is as follows:

$$\Psi(p(\theta), w(\theta); \lambda) = E_{\Theta} \{\pi_B(p(\theta), w(\theta), \theta)\} + \lambda \cdot E_{\Theta} \{\pi_A(p(\theta), w(\theta), \theta)\}, \quad (3)$$

where the parameter $\lambda \in [0, 1]$ denotes the weight accorded to the agent’s payoff relative to that of the principal.

As noted in the text, the contractarian approach in the absence of bonding and liquidity constraints provides an intuitive case for setting $\lambda = 1$. In the presence of such constraints, however, ex ante bargaining need not imply joint wealth maximization. To see why, consider the situation pictured in Figure A2, which illustrates the ex ante contractual “choice set” plotting the agent’s expected payoff on the horizontal axis and the principal’s on the vertical axis. The arc WV in Figure A2 represents the frontier of incentive-compatible payoffs that are available to the players through choices of contractual terms $\{p, w, D\}$. As is typical, WV is convex and downward sloping. Ex ante negotiation between the parties determines which contractual terms they will settle on to govern their later relationship. Since utility is transferable in this

model, however, the possibility of up-front transfer payments allows the parties to expand this frontier along the negatively sloping, forty-five-degree line that intersects the joint-welfare-maximizing point X on the feasibility set. In particular, the payment of a “signing bonus” from the principal to the agent signifies an expansion to the southeast of X , represented by the points comprising segment XZ . Were the agent able to pay an up-front performance bond, the feasibility set could likewise expand in the northwest direction from X . If as I assume, however, the agent’s liquidity constraint makes the posting of such a bond impossible, the relevant pareto frontier consists of the modified arc WZ .

FIGURE A2: A GRAPHICAL INTERPRETATION OF A ’S WELFARE WEIGHT (λ)

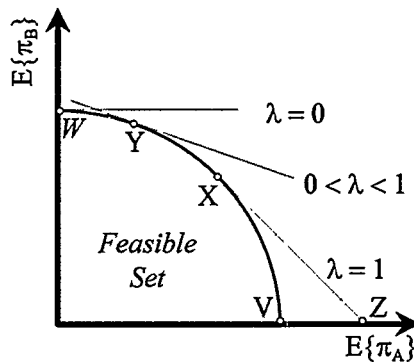

It is here that the game-theoretic interpretation of λ becomes clear. If the principal possessed all the ex ante bargaining power²³⁴ (as the conventional account implicitly assumes), the negotiated outcome would be at point W , which is tantamount to maximizing the principal’s expected payoff alone (i.e., $\lambda = 0$). As the agent possesses greater relative ex ante bargaining power, however, the negotiated outcome will yield an allocation elsewhere on the feasibility set, say at point Y , which corresponds to $0 < \lambda < 1$. Finally, when the agent possesses sufficiently large bargaining power, the negotiated outcome will fall somewhere on XZ , corresponding to $\lambda = 1$.²³⁵ Thus, in the analysis that follows I allow for any value of $\lambda \in [0, 1]$, with the interpretation that larger values of λ correspond to either (a) greater slack in A ’s capital constraints; or (b) increasingly large degrees of ex ante bargaining power for the agent.

234. The definition of “bargaining power” envisioned here (and in the text) is a precise one, corresponding to the undetermined parameter of the nonsymmetric Nash bargaining program. See, e.g., MARTIN J. OSBORNE & ARIEL RUBINSTEIN, BARGAINING AND MARKETS 11-23 (1990) (describing the symmetric and nonsymmetric Nash solutions).

235. Indeed, any outcome along XZ in the figure signifies a contract in which $\{p, w, D\}$ are set to induce the allocation X , including a signing bonus (which could be paid at the same time wages are paid) from the principal to the agent that moves them along the downward sloping segment XZ .

Reiterating, the contracting problem consists of design terms $\{p(\theta), w(\theta), D(\theta)\}$ to maximize $\Psi(p(\theta), w(\theta); \lambda)$, subject to the constraint that the agent be willing to participate (i.e., the agent's payoff exceeds $\mu(\theta; D(\theta))$). In addition, it will be necessary to introduce an incentive-compatibility condition for A when he possesses private information about θ . Mirroring the text, the following sections examine two informational structures: Section C analyzes the case of complete information, in which the project type θ is both observable to B and verifiable in court. I will demonstrate that in such a perfect-information world it is theoretically possible to write a completely contingent contract and, accordingly, the optimal default rule need be concerned only with maximizing production efficiencies. Section D analyzes the case in which the agent has private, nonverifiable information about project type. In such a second-best world, the noncontractibility of θ necessitates "incentivizing" the agent's compensation package, a necessity that generically prevents the parties from completely exploiting all potential gains from trade.

C. Complete Information

Suppose first that the state of the world is fully contractible, in that both parties can observe, and a court can verify, the project type θ . Because information is complete, the contract can ignore truth-telling constraints, and need only be calibrated to be "individually rational" (IR)—in other words, after learning θ , A must receive a payoff from the contract that is at least as high as if he took his best outside option $\mu(\theta; D(\theta))$. The optimal contracting problem is therefore as follows:

$$\begin{aligned} & \text{Max}_{p, w, D} \Psi(p(\theta), w(\theta), \lambda) \text{ subject to} \\ & \text{(IR) } \pi_A(p(\theta), w(\theta), \theta) \geq \mu(\theta; D(\theta)) \quad \forall \theta \in \Theta. \end{aligned} \quad (4)$$

Beyond the participation constraint of the agent, however, the parties may split the surplus in any manner they wish for any state θ . One's natural conjecture is that, with complete information, contracts will be "first-best" efficient. This turns out to be the case, as embodied in Proposition 1 (stated without proof) below:

Proposition 1: *When θ is common knowledge, the optimal contract $\{p^*(\theta), w^*(\theta), D^*(\theta)\}$ is given by:*

$$\begin{aligned} p^*(\theta) &= \begin{cases} 1 & \forall \theta \ni C_A(\theta) < C_B(\theta); \\ 0 & \text{else} \end{cases}; \\ w^*(\theta) &= \underline{\mu} - p^*(\theta) \cdot h^c(\theta); \\ D^*(\theta) &\geq p^*(\theta) \cdot h^c(\theta) + (1 - p^*(\theta)) \cdot [1 - C_A(\theta)]; \end{aligned}$$

where $h^c(\theta) = \text{Max}\{0, 1 - C_A(\theta)\}$ for $\lambda < 1$ and $0 \leq h^c(\theta) \leq \text{Max}\{0, 1 - C_A(\theta)\}$ for $\lambda = 1$.

The contract described by Proposition 1 is straightforward. Most significantly and, just as one would expect, the optimal contract allocates the project to the agent when and only when his production cost is less than the principal's. Note that this "lowest cost producer" authority rule is *independent* of λ . This feature results from the verifiability of θ , which gives the parties tremendous freedom to distribute the aggregate surplus in each possible state of the world without jeopardizing the agent's incentives.

In contrast to the authorization component, however, the wage and damages components of the first-best contract need not be unique. Regarding the former, the proposition states that A 's wage consists of a flat transfer, μ , less a "kickback" transfer from A to B in the amount $h^c(\theta)$, which takes effect only when the agent receives production authority.²³⁶ When $\lambda < 1$, this kickback amounts to complete disgorgement of all the agent's private profits. When $\lambda = 1$, however, transfer payments from the agent to the principal play no role in the welfare calculus and may be anywhere between zero and complete disgorgement. Regarding the damages component, $D^*(\theta)$, the proposition states simply that the damages payment must be set sufficiently high to ensure that the agent is willing to participate in the disclosure mechanism. This means that damages must be at least as high as the kickback when the participating agent would receive authority, and at least as high as full disgorgement when he would not. I will comment more on the damages "background rule" in the next section, noting for now that, in a perfect information environment, the optimal damages amount need not be bounded from above when a disclosure mechanism exists.

D. *Private Information*

Now consider the contract design problem under the alternative circumstance in which the agent possesses private information about the opportunity. Explicitly, suppose A observes θ , but this information is unobservable to B and unverifiable (or prohibitively costly to verify) in court. This informational asymmetry implies that complete contracts are not possible, since the state of the world is no longer verifiable. What remains contractible depends on whether the agent participates in the disclosure mechanism.

For the *participating agent*, it is still possible to contract on A 's *representation* (or "report") about the project type, which (following the text) I shall denote as t . Indeed, the parties can allow the authority and compensation terms $p(\cdot)$ and $w(\cdot)$ to vary with the agent's report. Doing so,

236. Note that this kickback or reduction in wages corresponds precisely to the liquidated damages d hypothesized in the example analyzed in the text.

however, introduces an important new dimension to the problem: It is now possible for A to misrepresent the nature of the project in order to manipulate B 's decision. The contractual terms must take account of this strategic incentive.

For the *nonparticipating* agent, on the other hand, the information asymmetry further constrains the contract terms. Indeed, unlike the disclosure components, the damages component $D(\cdot)$ cannot be made contingent on A 's report: Nonparticipation implies that A makes no report. Thus, the most that the contract can do here is to specify a flat payment (i.e., $D(\theta) = D$) in the event that A decides to quit and appropriate rather than to disclose. The agent's reservation utility is therefore $\mu(\theta; D) = \underline{\mu} + \text{Max}\{0, 1 - C_A(\theta) - D\}$. For future reference, I will define (θ_0, θ_1) as the interval of project types that yield a strictly positive *net* payoff to the nonparticipating appropriator (i.e., even after paying damages D).²³⁷

To reflect the report-based nature of the disclosure terms, let $\pi_A(p(t), w(t), \theta)$ denote the participating agent's expected *gross* payoff under the contract when the agent observes θ and reports t . Similarly, denote $R_A(p(t), w(t), D, \theta)$ as the agent's *net* payoff over her reservation utility $\mu(\theta; D)$, an expression that I shall repeatedly refer to as A 's "information rent schedule." Using equation (1), the information rent schedule is given by²³⁸

$$\begin{aligned} R_A(p(t), w(t), D, \theta) &= \pi_A(p(t), w(t), \theta) - \mu(\theta, D) \\ &= p(t) \cdot \text{Max}\{0, 1 - C_A(\theta)\} \\ &\quad + w(t) - \underline{\mu} - \text{Max}\{0, 1 - C_A(\theta) - D\}. \end{aligned} \tag{5}$$

The revelation principle permits one to limit her inquiry to direct mechanisms that are individually rational and incentive compatible: that is, contractual terms that induce both (1) participation ("individual rationality," or IR) *and* (2) truthful revelation ("incentive compatibility," or IC) from the agent.²³⁹ The contracting problem, then, is to design terms $\{p(\theta), w(\theta), D\}$ that solve the following program:

237. It is easily verified that $\theta_0 = \alpha - (1 - c_A) + D$ and $\theta_1 = \alpha + (1 - c_A) - D$.

238. The reader might notice here that an intermediate specification of the information structure is possible if θ becomes verifiable whenever B takes the project. In particular, one could specify two distinct wage schedules: $w_0(t)$, should B forego the project, and $w_1(\theta)$, should B accept the project. Note that the latter wage schedule is contingent on the true θ rather than A 's report. The effects of this added complexity appear to be modest, and thus I confine myself to the more tractable case where the project type is never verifiable in court.

One might wonder at this point whether a second type of private information is relevant: A 's knowledge of whether there ever was a project in the first place. The framework of this section captures this possibility, however, since it admits a range of project types that are unprofitable to both the firm and the fiduciary. A report of a mutually unattractive project is tantamount to a report that A saw "no project." One might also consider a third unobservable state: the agent's action (i.e., whether he has secretly accepted a project). This possibility is discussed in note 223, *supra*.

239. See generally DREW FUDENBERG & JEAN TIROLE, GAME THEORY 244-57 (1991) (discussing the concepts of individual rationality and incentive compatibility in the context of several mechanism design games). Recall that only the former condition was also necessary in the complete information model.

$$\begin{aligned} & \text{Max}_{p(\theta), w(\theta), D} \Psi(p(\theta), w(\theta); \lambda) \\ & \text{subject to (IR) } R_A(p(\theta), w(\theta), D, \theta) \geq 0 \quad \forall \theta \in \Theta; \\ & \text{(IC) } \theta \in \text{argmax}_t \{R_A(p(t), w(t), D, \theta)\}. \end{aligned} \tag{6}$$

For notational convenience, whenever the contract is structured so that A truthfully reveals θ , denote $R_A(\theta)$ to represent $R_A(p(\theta), w(\theta), D, \theta)$. Additionally, it is convenient to partition the project space Θ according to A 's incentives (before accounting for contractual terms) to appropriate the project. Define Θ_a (Θ_d) as the set of project types sufficiently below (above) α that the agent could only operate at a loss. Similarly, denote Θ_b (Θ_c) as the interval of the project that the agent could accept profitably, and for which the agent's costs are strictly decreasing (increasing) in θ .²⁴⁰ Only in these latter regions does the agent present a serious threat of appropriating the opportunity.

To characterize the solution to (7), one must determine what additional restrictions the (IC) constraint places on the set of admissible contract terms. Indeed, once the contract must be structured to induce truthful revelation, it may no longer be possible to "fine tune" the terms as was possible in the complete information case. An analysis of the (IC) constraint reveals the following lemma, which will prove central to later results:

Lemma 1: *A contract $\{p(\theta), w(\theta); D\}$ is incentive compatible if and only if the following conditions hold almost everywhere:*

- (i) $p(\theta)$ nondecreasing $\forall \theta \in \Theta_a \cup \Theta_b$;
- (ii) $p(\theta)$ nonincreasing $\forall \theta \in \Theta_c \cup \Theta_d$;
- (iii) $p(\theta) = p(t) \quad \forall \{\theta \in \Theta_a \cup \Theta_b, t \in \Theta_c \cup \Theta_d : |\alpha - \theta| = |\alpha - t|\}$;
- (iv) $R'_A(\theta) = \begin{cases} 0 & \Leftrightarrow \{\theta \in \Theta_a\} \\ p(\theta) & \Leftrightarrow \{\theta \in \Theta_b | \theta < \theta_0\} \\ p(\theta) - 1 & \Leftrightarrow \{\theta \in \Theta_b | \theta \geq \theta_0\} \\ 1 - p(\theta) & \Leftrightarrow \{\theta \in \Theta_c | \theta > \theta_1\} \\ -p(\theta) & \Leftrightarrow \{\theta \in \Theta_c | \theta \leq \theta_1\} \\ 0 & \Leftrightarrow \{\theta \in \Theta_d\}. \end{cases}$

Proof: The net payoff for the fiduciary observing θ and reporting t is given by:

$$\begin{aligned} R_A(t | \theta) = & p(t) \cdot \text{Max}\{0, 1 - C_A(\theta)\} + w(t) \\ & - \underline{\mu} - \text{Max}\{0, 1 - C_A(\theta) - D\}. \end{aligned} \tag{7}$$

Incentive compatibility is equivalent to $R_A(\theta|\theta) \geq R_A(t|\theta)$, for all t, θ in Θ :

240. Thus, $\Theta_a = [\underline{\theta}, \alpha - (1 - c_A)]$; $\Theta_d = (\alpha + (1 - c_A), \bar{\theta}]$; $\Theta_b = [\alpha - (1 - c_A), \alpha]$; and $\Theta_c = (\alpha, \alpha + (1 - c_A)]$.

$$\begin{aligned}
 [p(\theta) - p(t)] \cdot [\text{Max}\{0, 1 - C_A(\theta)\} - \text{Max}\{0, 1 - C_A(t)\}] \\
 \equiv [p(\theta) - p(t)] \cdot [\Delta(\theta, t)] \geq 0.
 \end{aligned}
 \tag{8}$$

Assume (without loss of generality) that $\theta > t$. It then follows from the definition of $C_A(\cdot)$ that when θ and t are both in Θ_a or both in Θ_b , we have $\Delta(\theta, t) = 0$; when θ and t are both in Θ_c , we have $\Delta(\theta, t) > 0$; and when θ and t are both in Θ_e , we have $\Delta(\theta, t) < 0$. This satisfies conditions (i) and (ii). Condition (iii) follows immediately by noting that $\Delta(\theta, t) = -\Delta(t, \theta)$. Finally, the last condition is satisfied by imposing the envelope condition on the θ derivative of $R_A(\theta|\theta)$. Sufficiency is satisfied by noting that $R(\cdot)$ satisfies the single crossing property in each subregion of Θ . Q.E.D.

Because the conditions reported in Lemma 1 vary slightly from the standard mechanism design analysis, they require some elaboration. Conditions (i) and (ii) represent the counterpart of what most mechanism design approaches refer to as the “monotonicity” constraint. In the usual case, incentive compatibility mandates that the decision function ($p(\theta)$ in this case) be monotonic in the agent’s type. The typical condition turns out not to hold here, because the agent’s private payoff does not satisfy a strict definition of the “single crossing property.”²⁴¹ Consequently, the monotonicity condition requires modification. Conditions (i) and (ii) represent the needed alteration, mandating that the authority function be weakly increasing as the project type θ approaches the agent’s specialty α from either direction.

Condition (iii), which is absent from most standard mechanism design models, states that in an incentive compatible contract, $p(\theta)$ must be symmetric around the agent’s specialty α . This condition is an artifact of the symmetric payoff structure. Note also the interdependence of the symmetry condition (iii) and the monotonicity conditions (i) and (ii): If a given $p(\theta)$ satisfies the symmetry constraint and either of the two monotonicity constraints, then it *must* also satisfy the remaining monotonicity constraint.

Finally, Condition (iv) describes the slope of the agent’s information rent schedule, $R_A(\theta)$. The slope expression is a consequence of standard first-order conditions for truth-telling, which ensure that the agent’s choice of report is locally optimal. Unlike many standard mechanism design problems, in which the agent’s information rents are also monotonic in the agent’s type, one can see from Condition (iv) that the slope of A ’s rent schedule changes sign numerous times. This non-monotonicity stems from both the symmetric payoff structure and the fact that the agent’s reservation utility, $\mu(\theta; D)$, is type-dependent. As Lemma 1 illustrates, the agent’s rent schedule is flat between $\theta = \underline{\theta}$ and $\theta = \alpha - (1 - c_A)$; nondecreasing between $\theta = \alpha - (1 - c_A)$ and $\theta = \theta_0$; and nonincreasing between $\theta = \theta_0$ and $\theta = \alpha$. The symmetry condition (iii) ensures that the agent’s rent function is the mirror image for $\theta > \alpha$.

241. $R(p, w, \theta)$ is said to satisfy the single crossing property if R is monotonic nondecreasing in p and w , and $|\partial R / \partial p| / (\partial R / \partial w)$ is monotonic in θ . It is this last condition that is satisfied only piecewise for the specified function, which gives rise to condition (iii).

The non-monotonicity of the rent schedule is important because the design of the optimal contract typically begins with identifying the agent type that receives the lowest information rents from the contract (hereinafter the “minimum rent agent type”) and constructing the incentive contract around that agent type. Accordingly, Lemma 1 suggests two candidates for the minimum rent agent type: Either (1) it consists of a pooled group of agent types on the extremes of Θ (i.e., $\theta \in \Theta_a \cup \Theta_d$); or (2) it consists of a single agent type located at $\theta = \alpha$. Which of these candidate sets binds the participation constraint, however, depends on the relative magnitude of the damages component D . In general, when D is “large,” so that virtually all nonparticipating agent types are deterred from appropriating, the participation constraint will tend to bind on the extremes of Θ . Conversely, when D is “small,” so that virtually no nonparticipating agent type is deterred from appropriating, the participation constraint will tend to bind on the interior at $\theta = \alpha$. In order to characterize the optimal contract fully, it is necessary to consider both of these possibilities *ad seriatim*.

Consider first the case in which D is sufficiently large that the participation constraint binds at the extremes (and thus the minimum rent agent types consist of $\{\theta: \theta \in \Theta_a \cup \Theta_d\}$). Integrating the local optimality condition (iv) from Lemma 1, one can construct an indirect expression for the agent’s rent function:

$$R_A(\theta) = \underline{R}_A + \begin{cases} \int_{\theta}^{\theta} p(t)dt - \int_{\theta_b}^{\text{Max}\{\theta, \theta_b\}} 1dt & \text{if } \theta \in \Theta_b \\ \alpha^{-(1-c_A)} & \theta_b \\ \int_{\theta}^{\alpha+(1-c_A)} p(t)dt - \int_{\theta}^{\theta_1} 1dt & \text{if } \theta \in \Theta_c \\ \theta & \text{Min}\{\theta, \theta_1\} \end{cases} \tag{9}$$

where the constant of integration, \underline{R}_A , denotes the expected net payoff of the minimum rent agent type(s). Taking expectations over Θ and integrating by parts yields the following indirect *expected* rent schedule for A under local incentive compatibility:

$$E_{\Theta}[R_A(\theta)] = \underline{R}_A + \int_{\alpha-(1-c_A)}^{\alpha+(1-c_A)} p(\theta) \cdot \left[\frac{|F(\alpha) - F(\theta)|}{f(\theta)} \right] dF(\theta) - \int_{\theta_0}^{\theta_1} \left[\frac{|F(\alpha) - F(\theta)|}{f(\theta)} \right] dF(\theta). \tag{10}$$

Combining (10) with the definition of the agent’s rent function allows one to derive the following expression for the agent’s expected wage:

$$\begin{aligned}
 -E_{\Theta}[w(\theta)] &= \int_{\alpha-(1-c_A)}^{\alpha+(1-c_A)} p(\theta) \left\{ 1 - C_A(\theta) - \left[\frac{|F(\alpha) - F(\theta)|}{f(\theta)} \right] \right\} dF(\theta) \\
 &- \int_{\theta_0}^{\theta_1} p(\theta) \left\{ 1 - C_A(\theta) - D - \left[\frac{|F(\alpha) - F(\theta)|}{f(\theta)} \right] \right\} dF(\theta) - (\underline{R}_A + \underline{\mu}).
 \end{aligned}
 \tag{11}$$

Finally, recall from (3) that the objective function of the contract design problem is to maximize $\Psi(p(\theta), w(\theta); \lambda) = E_{\Theta}\{\pi_B(\theta)\} + \lambda \cdot E_{\Theta}\{\pi_A(\theta)\}$ by choice of terms $\{p(\theta), w(\theta), D\}$. Equation (11) can be used both to eliminate the expected wage component from (3) and to impose the participation and local incentive compatibility constraints on the problem, yielding the following indirect welfare function:

$$\begin{aligned}
 \Psi(p(\theta); \lambda, D, \underline{R}_A) &= \int_{\beta-1}^{\beta+1} [1 - p(\theta)] \cdot (1 - C_B(\theta)) dF(\theta) - (1 - \lambda) \cdot \underline{R}_A + \lambda \underline{\mu} \\
 &+ \int_{\alpha-(1-c_A)}^{\alpha+(1-c_A)} p(\theta) \left\{ 1 - C_A(\theta) - (1 - \lambda) \left[\frac{|F(\alpha) - F(\theta)|}{f(\theta)} \right] \right\} dF(\theta) \\
 &- (1 - \lambda) \cdot \int_{\theta_0}^{\theta_1} \left\{ 1 - C_A(\theta) - D - \left[\frac{|F(\alpha) - F(\theta)|}{f(\theta)} \right] \right\} dF(\theta).
 \end{aligned}
 \tag{12}$$

Although the above derivation assumes throughout that the participation constraint binds on the extremes ($\theta \in \Theta_a \cup \Theta_d$), one can derive an expression analogous to (12) under the alternative hypothesis that the minimum rent agent type is interior ($\theta = \alpha$) (see below).

Notice that because the agent's expected wage has been substituted out of $\Psi(\cdot)$, optimizing (12) over $p(\theta)$ and D implicitly defines the optimal $w(\theta)$ function as well. Further, note that the expression is non-increasing in \underline{R}_A (the net payoff of the minimum rent agent type). This suggests that the optimal contract will, in general, set $\underline{R}_A = 0$, thereby paying zero rents to all the minimum rent agent types. (I will make this assumption in the derivations that follow.) Finally, and most importantly, there are no interaction effects between the authority component $p(\cdot)$ and the damages component D . The authority component enters only through the first and third terms of (12), while the damages component enters only through the fourth term. This observation enables one to solve for the optimal terms independent of each other.

Proceeding along these lines, let us begin with characterizing the optimal damages term D . It is straightforward to differentiate the indirect welfare function $\Psi(\cdot)$ with respect to D . Doing so using the expression in (12) yields the interesting result that $\partial\Psi(\cdot)/\partial D = 0$. Moreover, differentiating the analogous expression when the minimum rent agent type is $\theta = \alpha$, one finds that $\partial\Psi(\cdot)/\partial D = (1 - \lambda) \geq 0$. Viewed together, these results are intriguing for they

suggest that when D is “small” (so that the minimum rent type is interior) there is a nonnegative benefit associated with marginal increases in D . On the other hand, once D grows sufficiently “large” (so that the participation constraint binds on the extremes), there is neither a benefit nor a cost associated with increasing D . This immediately implies the following proposition:

Proposition 2: For every incentive compatible $p(\theta)$ and for all $\lambda \in [0, 1]$, $\exists \underline{D} \in [0, 1 - c_A]$ such that $\text{argmax}_D \Psi(p(\theta); \lambda, D, \underline{R}_A) = \{D \mid D \geq \underline{D}\}$.

Proof: Direct differentiation of (12) and application of the envelope theorem yields the result that for sufficiently large D , $\partial \Psi(\cdot) / \partial D = 0$. If, however, D is sufficiently small that the incentive compatibility constraint is binding at $\theta = \alpha$, the analogous expression to (12) is given by:

$$\begin{aligned} \Psi(p(\theta); \lambda, D, \underline{R}_A) = & \int_{\beta-1}^{\beta+1} [1 - p(\theta)] \cdot (1 - C_B(\theta)) dF(\theta) \\ & - (1 - \lambda) \cdot \underline{R}_A + \lambda \underline{\mu} \\ & + \int_{\alpha - (1 - c_A)}^{\alpha} p(\theta) \left\{ 1 - C_A(\theta) - (1 - \lambda) \left[\frac{F(\theta)}{f(\theta)} \right] \right\} dF(\theta) \\ & + \int_{\alpha}^{\alpha + (1 - c_A)} p(\theta) \left\{ 1 - C_A(\theta) - (1 - \lambda) \left[\frac{1 - F(\theta)}{f(\theta)} \right] \right\} dF(\theta) \\ & - (1 - \lambda) \cdot \int_{\theta_0}^{\alpha} \left\{ 1 - C_A(\theta) - D - \left[\frac{F(\theta)}{f(\theta)} \right] \right\} dF(\theta) \\ & - (1 - \lambda) \cdot \int_{\alpha}^{\theta_1} \left\{ 1 - C_A(\theta) - D - \left[\frac{1 - F(\theta)}{f(\theta)} \right] \right\} dF(\theta). \end{aligned} \tag{13}$$

Differentiation of this expression (along with the envelope theorem) yields the result that $\partial \Psi(\cdot) / \partial D = (1 - \lambda)$. Thus, for all $\lambda \leq 1$, it is optimal (and strictly optimal for $\lambda < 1$) to increase D to the point where the incentive compatibility constraint is binding at the extremes of A 's profitable domain. Q.E.D.

The interpretation of Proposition 2 is as follows. Recall that the value of D creates what is essentially a “background rule” upon which the remaining disclosure components of the contract are built. Proposition 2 states that the optimal damages term is not unique, but rather consists of a set bounded below by some $\underline{D} \geq 0$. Because increasing D weakly relaxes the constraints on the optimal contracting problem (6) without affecting the objective function, an optimal contract can entail a fairly punitive background rule, with no upper bound (or alternatively an injunctive remedy). This result is reminiscent of the “penalty default” literature, which similarly hypothesizes that under certain

conditions, punitive background rules can be consistent with optimality, *not* because contracting parties wish to be bound by them, but rather because such rules have the ability to “force” information disclosure from a privately-informed party.²⁴² In this context, the optimal contract may tend to select a seemingly “draconian” background rule (or its strategic equivalent) in order to enhance the agent’s incentive to participate in the disclosure mechanism.²⁴³ Examples of such penalty-like background rules include injunctive relief, punitive damages, and the imposition of a constructive trust against the nonparticipating appropriator. Interestingly, each of these remedies can be found in the case law for fiduciaries who appropriate corporate projects without first disclosing them.

Although Proposition 2 is certainly consistent with the use of penalty default rules to govern nondisclosing appropriators, one should take care not to over-interpret this result. Recall that the proposition merely states that a punitive default rule is *sufficient* to implement the optimal contract, not that it is *necessary*. Although a penalty default is indeed a member of the optimal set, other less extreme rules may be as well. In fact, we shall see below that it is not critical for the default rule to be excessively draconian; it need only be slightly more punitive than the terms of the optimal disclosure component of the contract to induce participation.

Nevertheless, were a court attempting to use Proposition 2 to select a “categorical” default rule that would apply to all circumstances of nondisclosure, it could never err by placing large restrictions on the nonparticipating appropriator. I shall therefore assume for the remainder of this subsection that D is set sufficiently high so that the participation constraint binds at the extremes rather than in the interior. Doing so ensures that the indirect objective stated in (12) is always the relevant one with which to proceed, and it still allows one to solve for the minimum threshold value of D that ensures optimality.

That said, I will now proceed to characterize the remaining terms of the optimal contract using (12). As per the discussion from Figure 2, the respective profitable domains of the parties fall into one of three natural categories. In the No Overlap case, the principal’s and agent’s respective specialties (β and α) are so distinct that their interests are mutually exclusive (though not exhaustive). In the Partial Overlap case, their respective specialties are sufficiently similar that they each privately covet *some* of the same project types (but not others). Finally, in the Complete Overlap case, the parties are so similar that the principal always covets any project that is attractive to the agent.²⁴⁴

242. See Ian Ayres & Robert Gertner, *Filling Gaps in Incomplete Contracts: An Economic Theory of Default Rules*, 99 YALE L.J. 87 (1989).

243. In game-theoretic terms, this is tantamount to choosing large threats *off the equilibrium path* so as to ensure desirable behavior *along the equilibrium path*.

244. Note that because the principal faces no fixed costs, in the Complete Overlap case, the principal’s private interests will strictly nest those of the agent.

To solve the contracting program, I will maximize (12) for each of these cases in sequence. The method for characterizing the optimal contract is otherwise quite standard and proceeds as follows. For each case, I will explicitly impose the symmetry constraint (iii) upon the objective function. I will then characterize the solution to a “relaxed” program, which disregards the monotonicity constraints (i) and (ii). If the solution to the relaxed program is monotonic, then it must also be the solution for the fully-constrained problem. If it is not, however, one must explicitly introduce monotonicity constraints into the optimization problem through dynamic programming techniques.

1. *No Overlap Case*

Consider first the case in which the respective profitable domains for the principal and agent are completely disjoint. In other words, suppose that α and β are sufficiently distant so that there exist no projects that are simultaneously profitable to both parties. In this case, the intervals of integration for the first two components of (12) are also disjoint, and each can be considered independently. As mentioned above, the technique for characterizing the optimal contract is to solve a “relaxed” problem that maximizes $\Psi(\cdot)$ subject to local optimality and symmetry conditions from Lemma 1, but free from the monotonicity conditions. From the lemma, symmetry mandates that $p(\theta) = p(2\alpha - \theta) \forall \theta \in \Theta$. Imposing this condition on (12)—which already embodies the local optimality condition—and maximizing point-wise yields the following:

Proposition 3.1: *Suppose $\beta + 1 < \alpha - (1 - c_A)$. The solution to the relaxed problem is given by $\{p^*(\theta), w^*(\theta), D^*\}$, where:*

$$p^*(\theta) = \begin{cases} 1 & \forall \theta \in [\hat{\theta}, 2\alpha - \hat{\theta}] \subseteq \Theta_b \cup \Theta_c; \\ 0 & \text{else} \end{cases}$$

$$w^*(\theta) = \underline{\mu} - p^*(\theta) \cdot [1 - C_A(\hat{\theta})];$$

$$D^* \geq \underline{D} \equiv [1 - C_A(\hat{\theta})];$$

and $\hat{\theta}$ is characterized by

$$\hat{\theta} = \alpha - (1 - c_A) + (1 - \lambda) \left[\frac{F(2\alpha - \hat{\theta}) - F(\hat{\theta})}{f(2\alpha - \hat{\theta}) + f(\hat{\theta})} \right].$$

Proof: Using Proposition 2 to justify setting D arbitrarily high, and imposing the symmetry condition (iii), the expression in (12) becomes:

$$\begin{aligned}
 & \text{Max}_{p(\theta) \in [0,1]} \int_{\beta-1}^{\beta+1} [1 - p(\theta)] \cdot (1 - C_B(\theta)) dF(\theta) + \lambda \cdot \underline{\mu} \\
 & + \int_{\alpha - (1 - c_A)}^{\alpha} p(\theta) \left\{ (1 - C_A(\theta)) - (1 - \lambda) \left[\frac{F(2\alpha - \theta) - F(\theta)}{f(\theta) + f(2\alpha - \theta)} \right] \right\} [f(\theta) + f(2\alpha - \theta)] d\theta \\
 & - (1 - \lambda) \cdot \int_{\theta_0}^{\theta_1} \left\{ 1 - C_A(\theta) - D - \left[\frac{F(\alpha) - F(\theta)}{f(\theta)} \right] \right\} dF(\theta)
 \end{aligned}
 \tag{14}$$

Point-wise differentiation yields the condition given in the proposition. Sufficiency is ensured by the concavity of the objective function.

To develop the intuition behind the proposition, assume for now that the solution to the relaxed problem is also the solution to the general problem. When $\lambda = 1$, the contract described in Proposition 3.1 has an exceptionally simple structure. It authorizes the agent to take on any project that lies on the interval $[\alpha - (1 - c_A), \alpha + (1 - c_A)]$. In other words, when B 's and A 's interests do not overlap, the optimal contract simply allocates the project to whomever can perform it profitably. This result is not terribly surprising, for in the No Overlap case, the principal and agent do not have competing interests, at least in terms of production decisions. Neither covets projects that the other could perform profitably. The wage component of the contract is similarly simple, specifying that the agent receive $w(\theta) = \underline{\mu}$ regardless of θ . Viewed together, then, the participating agent's compensation package under a joint wealth objective with no overlap consists of a flat wage *plus* authority to pursue independently any project that interests him. There are no required "kickbacks" to the principal in the event that the agent pursues the project.

As one might guess, the liberal contractual terms when $\lambda = 1$ makes participation extremely attractive to the agent. This provides a tremendous amount of freedom in choosing the background damages amount D to govern the nonparticipating appropriator. Indeed, as the proposition states, the minimum threshold for an optimal D in this case is $\underline{D} = 0$ (though, of course, any value above \underline{D} is also optimal).

When $\lambda < 1$, on the other hand (due, say, to bonding constraints), the optimal No Overlap contract places greater restrictions on the agent's authority to pursue projects individually. Indeed, as the proposition illustrates, when $\lambda < 1$ the principal will authorize the agent to pursue a project if and only if $\theta \in [\hat{\theta}, 2\alpha - \hat{\theta}] \subset (\alpha - (1 - c_A), \alpha + (1 - c_A))$. In other words, the contract prevents the agent from accepting certain "fringe" projects, *even though* he could perform them profitably, and *even though* the principal is wholly uninterested in them.

This restrictive feature is due to what one might call a "rent appropriation effect": When $\lambda < 1$, transfers from the agent to the principal now "matter," in that they have a net positive marginal effect of $(1 - \lambda)$ on the objective function

$\Psi(\cdot)$. Therefore, it is optimal for B to extract rents from A in exchange for favorable authorization decisions. The rent appropriation effect is best illustrated by considering how $p(\theta)$ interacts with the wage component, $w(\theta)$. Since transfer payments are now non-neutral, a first-best contract—if feasible—would mandate that whenever the agent receives authorization, he must disgorge to the principal the full amount of the profits he earns. Such “perfect disgorgement,” however, is not generally possible in a second-best world when θ is privately known by the agent. Indeed, were the principal to announce such a policy, the agent would have a strong incentive to misrepresent the project type as being one that “just barely” turns a profit, knowing that the principal could never verify such a statement. Consequently, when the agent possesses private information, the only incentive-compatible manner by which the principal can extract rents from the agent is through a *uniform* wage reduction, exacting a fixed “price” in exchange for authorizing the agent to pursue the project individually.

Exacting such a uniform price, however, imposes a fundamental tradeoff in terms of the social welfare function $\Psi(\cdot)$. This tradeoff is pictured in Figure A3, in which the area of shaded rectangle is related to the expected transfer payment made from the agent to the principal. The height of the rectangle corresponds to the size of the transfer payment (in the form of a wage reduction) made from the agent to the principal for any project that the agent accepts. Note that as the required transfer payment grows, the height of the rectangle also increases, reflecting the benefit associated with marginal increases in the authorization price. The width of the rectangle, on the other hand, is related to the probability that the agent will take a project and pay the mandated strike price.²⁴⁵ As the wage reduction increases, this dimension of the rectangular region decreases, reflecting the cost associated with a larger authorization price. The optimal contract strikes a balance between these competing effects.²⁴⁶ One might notice that this intuition is reminiscent of the monopoly pricing problem, in which the monopolist continues to raise her price until the lost profits from rationing out the *marginal* consumer are just equal to the benefits of additional revenue from *inframarginal* consumers. Analogously, when $\lambda < 1$, the optimal contract sacrifices projects lying on the marginal fringes of the agent’s profitable domain in order to extract a transfer payment from authorizing the more lucrative (but less frequent) project types on the interior.

245. The width of the shaded area is only positively related to the probability that the agent takes the project. The actual probability is given by $F(2\alpha - \theta) - F(\theta)$.

246. Note that incentive compatibility mandates that the discontinuous $w^*(\theta)$ function in the figure is necessarily coordinated with the optimal $p^*(\theta)$ function, so that the marginal agent types receiving authorization (i.e., $\theta = \hat{\theta}$ and $\theta = 2\alpha - \hat{\theta}$) are just indifferent between receiving authorization along with a wage reduction on the one hand, and receiving their flat wage of \underline{w} on the other. Thus, any agent type receiving authorization to take a project must surrender a uniform amount of $1 - C_\lambda(\hat{\theta})$.

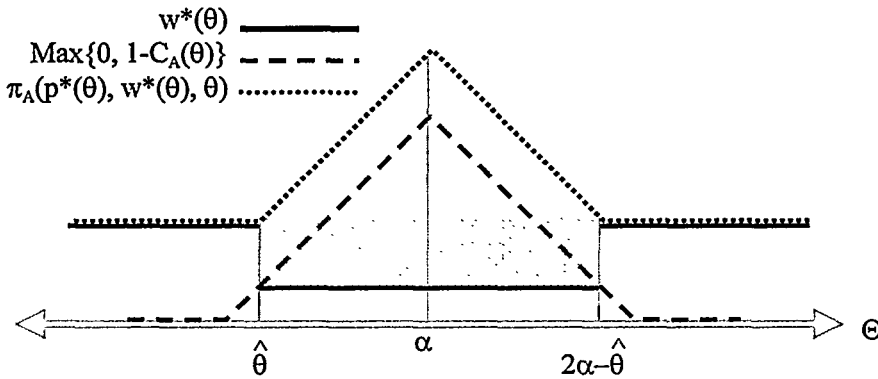
FIGURE A3: "STRIKE PRICE" FOR AUTHORIZATION IMPLICIT IN $w^*(\theta)$; $\lambda < 1$.

Given the pricing intuition underlying the wage component when $\lambda < 1$, it is interesting to note that the background damages term D also represents a type of "price" for taking a project, but one that represents the exercise price of the option to quit the firm and appropriate the opportunity. As illustrated above in Proposition 2, the optimal D^* is any value that makes exercising the option less attractive than participating in the disclosure mechanism for all agent types. This immediately suggests that D^* is necessarily bounded below by the implicit authorization price illustrated in Figure A3. Equivalently, as Proposition 3.1 states, $D^* \geq \underline{D} = 1 - C_A(\hat{\theta})$. Note that this lower bound is more restrictive than in the case of $\lambda = 1$ (though once again a "penalty default" will suffice for both).

As discussed above, the solution to the relaxed program solves the fully-constrained problem only if $p^*(\theta)$ is monotonic nondecreasing for $\theta < \alpha$.²⁴⁷ When $\lambda = 1$, monotonicity is clearly satisfied, since Proposition 3.1 defines $\hat{\theta}$ in closed form. When $\lambda < 1$, however, the definition of $\hat{\theta}$ is implicit, and here monotonicity conditions may fail. In such a circumstance, the typical approach is to posit restrictions on $F(\theta)$ sufficient to ensure that monotonicity conditions hold. It is possible to state an analogous condition here also, reflected in the following corollary:

Corollary 3.1.1: *If $[F(2\alpha - \theta) - F(\theta)]/[f(2\alpha - \theta) + f(\theta)] - \theta$ is nonincreasing $\forall \theta \in [\alpha - (1 - c_A), \alpha]$, then $\{p^*(\theta), w^*(\theta), D^*\}$ characterizes the optimal contract in the No Overlap case $\forall \lambda \in [0, 1]$.*

A few caveats to this corollary bear emphasis. First, the distributional condition Corollary 3.1.1 reports is merely *sufficient* for the relaxed solution to satisfy the general program. It is not necessary. Second, while the

247. Recall, since the symmetry condition (iii) has already been imposed on the problem, we need only check monotonicity condition (i) to be sure that both monotonicity conditions hold.

assumption does restrict the allowable family of distributions, the condition is *not* necessarily more restrictive than the standard monotone hazard rate assumption commonly made in the literature.²⁴⁸ Indeed, there are a number of distributions that satisfy both this condition and the standard monotone hazard rate assumption,²⁴⁹ and some which satisfy one but not the other.²⁵⁰ Moreover, even if it does not hold, and the solution of the relaxed problem violates the piecewise monotonicity constraints, the qualitative solution to the problem will remain. It will, however, be necessary to adopt a dynamic programming approach to “smooth” the nonmonotone portions of the relaxed solution.²⁵¹ Because the intuitions are similar, however, in what follows I shall confine my discussion to situations in which the relaxed solution is also the general solution.

2. *Partial Overlap Case: $\alpha - (1 - c_A) < \beta + 1 < \alpha + (1 - c_A)$:*

Suppose now that α and β are moderately close to one another, such that the principal’s and agent’s profitable domains partially overlap. In such a circumstance, the parties’ respective private interests sometimes coincide. This case is likely the most plausible one in practice, and, as it turns out, it is theoretically the most interesting one as well.

To facilitate exposition, consider a number of “sub-cases” corresponding to various degrees of Partial Overlap. The first relevant sub-case is confined to situations where $\lambda < 1$. Recall that when $\lambda < 1$, the optimal No Overlap contract precludes the agent from taking on certain projects lying on the “fringe” of his profitable domain. Because of this characteristic, the optimal No Overlap contract may still be feasible when the degree of overlap is sufficiently “small.” Explicitly, this occurs when $\alpha - (1 - c_A) < \beta + 1 \leq \hat{\theta}$, giving rise to the following:

Proposition 3.2(a): *When $\alpha - (1 - c_A) < \beta + 1 \leq \hat{\theta}$, the optimal contract $\{p^*(\theta), w^*(\theta), D^*\}$ is identical to that in Proposition 3.1 and Corollary 2.1.1.*

Proposition 3.2(a) essentially states that if the No Overlap contract precludes the agent from taking certain profitable fringe projects, then that same contract is optimal when there is “slight” overlap *if* the overlap consists solely of the identical fringe projects. This is not particularly surprising. Moreover, it

248. See, e.g., JEAN-JACQUES LAFFONT, THE ECONOMICS OF UNCERTAINTY AND INFORMATION 155-56 & n.4 (John P. Bonin & H el ene Bonin trans., 1989) (making the same assumption in presenting a general theory of incentive compatible contracts).

249. For example, distribution functions with linear densities, including the uniform distribution, satisfy both conditions.

250. For instance, normal distributions in which the variance is “small” may satisfy the generic condition but not this one. Conversely, *any* distribution that is unimodal at or “near” α satisfies the condition in Corollary 3.1.1, but may not satisfy the generic condition.

251. See, e.g., FUDENBERG & TIROLE, *supra* note 239, at 303-06 (1991) (analyzing the effect of binding and nonbinding monotonicity constraints in analyzing principal-agent relationships).

should be clear that this result is relevant only when $\lambda < 1$. Indeed, when $\lambda = 1$, Proposition 3.1 mandates that the agent receives authorization for all projects he finds profitable.

When $\beta+1 > \hat{\theta}$, however, the overlap of A 's and B 's respective specialties is sufficiently extensive that the optimal No Overlap contract is no longer feasible. This brings us to the second relevant—and arguably most important—sub-case for the Partial Overlap contract, in which $\hat{\theta} < \beta+1 \leq \alpha$. Following an identical procedure to the No Overlap case, one can once again impose the symmetry condition on (12) and differentiate point-wise, thereby yielding the following result:

Proposition 3.2(b): *Suppose $\hat{\theta} < \beta+1 \leq \alpha$. The solution to the relaxed problem is given by $\{p^*(\theta), w^*(\theta), D^*\}$ where:*

$$p^*(\theta) = \begin{cases} 1 & \forall \theta \in [\check{\theta}, 2\alpha - \check{\theta}] \subset \Theta_b \cup \Theta_c; \\ 0 & \text{else} \end{cases}$$

$$w^*(\theta) = \underline{\mu} - p^*(\theta) \cdot [1 - C_A(\check{\theta})];$$

$$D^* \geq \underline{D} \equiv [1 - C_A(\check{\theta})];$$

$$\text{and } \check{\theta} = \left(\frac{f(2\alpha - \check{\theta}) + f(\check{\theta})}{f(2\alpha - \check{\theta}) + 2f(\check{\theta})} \right) [\alpha - (1 - c_A)]$$

$$+ \left(\frac{f(\check{\theta})}{f(2\alpha - \check{\theta}) + 2f(\check{\theta})} \right) [\beta + 1] + [1 - \lambda] \left[\frac{F(2\alpha - \check{\theta}) - F(\check{\theta})}{f(2\alpha - \check{\theta}) + 2f(\check{\theta})} \right].$$

Proof: Imposing the symmetry constraint on (12) yields the following:

$$\begin{aligned} & \text{Max}_{p(\theta) \in [0,1]} \int_{\beta-1}^{\alpha-(1-c_A)} [1 - p(\theta)] \cdot (1 - C_B(\theta)) f(\theta) d\theta + \lambda \cdot \underline{\mu} \\ & + \int_{\alpha-(1-c_A)}^{\beta+1} [(1 - p(\theta)) \cdot (1 - C_B(\theta)) \cdot f(\theta) \\ & \quad + p(\theta) \cdot \{(1 - C_A(\theta)) \cdot [f(\theta) + f(2\alpha - \theta)] - (1 - \lambda)[F(2\alpha - \theta) - F(\theta)]\}] d\theta \\ & + \int_{\beta+1}^{\alpha} p(\theta) \{ (1 - C_A(\theta)) [f(\theta) + f(2\alpha - \theta)] - (1 - \lambda)[F(2\alpha - \theta) - F(\theta)] \} d\theta \\ & - (1 - \lambda) \cdot \int_{\theta_0}^{\theta_1} \left\{ 1 - C_A(\theta) - D - \left[\frac{F(\alpha) - F(\theta)}{f(\theta)} \right] \right\} dF(\theta). \end{aligned} \tag{15}$$

Point-wise differentiation immediately gives the reported result.

To develop the intuition behind this proposition,²⁵² assume arguing that the solution to the relaxed problem is also the solution to the general problem. Proposition 3.2(b) illustrates two competing effects in $p^*(\theta)$. To isolate them individually, consider first the joint-welfare objective ($\lambda = 1$), in which the third term in the definition drops out. Here, the only contractual decision with efficiency implications is determining at what point to transfer authority over the project from B to A . A natural candidate for this crossover point (and one advocated by numerous courts and commentators) is the point at which the agent becomes the lowest-cost producer.²⁵³ Such a “first-best” rule would mandate a crossover point in production authority at the point where the parties’ respective costs are the same (i.e., when $\theta = \theta^b = 1/2[\alpha - (1 - c_A)] + 1/2[\beta + 1]$).

Despite this sensible intuition, the contract illustrated in Proposition 3.2(b) does *not* in fact allocate authority to the lowest cost producer. Instead, it specifies an authority crossover point that lies to the *left* of the first-best crossover point. In more descriptive terms, the optimal contract will, for some commonly desired projects, allocate production to the *agent* even though the *principal* is the lowest cost producer for those projects.²⁵⁴

At first glance, this is an extremely surprising result. Indeed, by failing to allocate authority consistently to the low cost producer, the contract admits—by definition—a social inefficiency. It is this very type of inefficiency that the contractarian hypothesis presumes will be captured and distributed among the parties through bargaining. Moreover, even when agency problems render the first-best contract infeasible, one’s natural inclination is to conjecture that the contract will *under*-authorize (rather than *over*-authorize) the agent to pursue jointly coveted projects. Proposition 3.2(b) states not only that the optimal transition point diverges from first-best, but also that it does so in a direction that is somewhat counterintuitive.

Nonetheless, when one accounts for the constraints that incentive compatibility imposes on the contracting process, the intuition behind this result becomes clear. Recall from the foregoing discussion that in a private information context, the contract withholds authority from A by imposing a sufficiently large “authorization price” to deter him from appropriating. To do so while preserving incentive compatibility, however, the wage reduction must be *uniform* in nature, applying whenever A takes on a project. Consequently, *in order to deter acceptance of project type θ , the contract must also deter every project that is equally or less profitable than θ* . In other words, an incentive-compatible contract can withhold authority only by working “from the tails on in.”

This observation immediately reveals why a contract mandating a transfer of authority at the “first-best” crossover point (θ^b) is sub-optimal in a

252. The continuity of this contract and the No Overlap contract is easily confirmed. Simply impose the expression given in Proposition 3.1 for $[\beta + 1]$ in the above expression, and simplify.

253. This is essentially the argument of EASTERBROOK & FISCHER, *supra* note 4, at 140-43.

254. Mathematically, this result is easy to see: the optimal transfer point is defined implicitly by $\bar{\theta} = g(\bar{\theta})[\alpha - (1 - c)] + (1 - g(\bar{\theta}))[\beta + 1]$, but that $g(\bar{\theta}) > 1/2$ since $f(\theta) > 0$ for all $\theta \in \Theta$.

second-best world. Indeed, in order to deter A from encroaching across this first-best threshold, the contract must set an authorization price that also deters the agent from accepting projects symmetrically located on the *opposite* tail of A 's profitable domain. The loss of these "opposite tail" projects represents a pure social waste, since the agent is the only party who could perform them profitably. Thus, as illustrated in Figure A3 below, moving the contractual crossover threshold incrementally away from $\tilde{\theta}$ and towards the first-best point θ^b creates two competing effects: (1) efficiency gains by channeling more projects to the lowest-cost producer (reflected by reducing the region of deadweight loss denoted as Z); along with (2) *simultaneous* efficiency losses due to excess deterrence of projects at the far end of the agent's profitable domain (increasing the deadweight loss region denoted as Y). The optimal contract, in an attempt to balance these two concerns, authorizes the agent to perform tasks the principal could do more efficiently, in order to avoid overdetering the agent from pursuing projects that the principal would never accept. This inefficient result is rather striking, in that it reveals an agency cost that the parties cannot eliminate through ex ante contracting, *even when* liquidity constraints do not bind the agent. It is therefore somewhat more robust than the generic form of agency cost frequently studied in the literature,²⁵⁵ which sometimes can be avoided through ex ante contracting.

FIGURE A4: OPTIMAL CONTRACT TRADES OFF PRODUCTION INEFFICIENCIES Y AND Z .

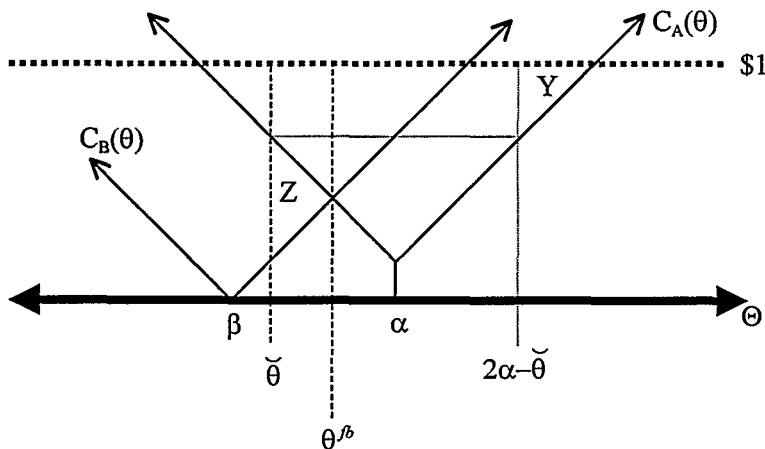

Unlike the pure contractarian No Overlap case, in the Partial Overlap case the optimal contract clearly mandates that a disclosing, authorized agent must "kick back" a transfer payment to the principal. This authorization price is equal to $1 - C_A(\tilde{\theta})$, and therefore it is functionally similar to that prescribed in Proposition 3.1 when $\lambda < 1$. It is important to notice that even though the

255. See, e.g., Grossman & Hart, *supra* note 184.

contract underdeters the agent from taking projects in the conflict region, the agent must nonetheless pay an implicit authorization price to take such projects. Finally, just as before, the lower bound to the optimal damages term is also this implicit authorization price of $1 - C_A(\bar{\theta})$, signifying that the background rule need only be marginally more punitive than the kickback term in order to ensure optimality.

When $\lambda < 1$, as Proposition 3.2(b) illustrates, the optimal authority transfer point depends on one additional effect. Along with the inefficiency tradeoff effect noted above (which pulls the crossover point to the left of the first best point), the “rent appropriation effect” from Proposition 3.1 recurs (which tends to pull the crossover point further to the right). When $\lambda < 1$, then, it is ambiguous whether optimal authority transfer will occur to the left or to the right of the first-best crossover point. Nonetheless, except for extremely special cases, these two effects do not negate each other. In general, then, the conclusion remains that the point at which the optimal contract transfers authority from the principal to the agent is *not* at the point where the agent becomes the most profitable producer.

As with the No Overlap case, the solution to the relaxed problem coincides with the solution to the general problem only if the authority parameter θ obeys the appropriate monotonicity conditions (ii) and (iii). If it does not, then one must once again use dynamic programming techniques to “splice” together a monotone optimum. This can be done using an approach identical to that for the No Overlap case and the discussion accompanying Corollary 3.1.1.

In addition to the sub-cases analyzed above, there remains another sub-case within the family of the Partial Overlap case configurations, where $\alpha < (\beta + 1) < (\alpha + (1 - c_A))$. The analysis of this case is relatively straightforward, and its insights are qualitatively identical to those of Proposition 3.2(b). It is therefore omitted.

3. Complete Overlap Case: $\beta - 1 < \alpha - (1 - c_A) < \alpha + (1 - c_A) < \beta + 1$.

In this configuration, the principal’s profitable domain completely nests the agent’s. Thus, any project that attracts the agent will similarly attract the principal. Moreover, because of the fixed component of the agent’s incremental cost, the principal has an absolute cost advantage for every project that both parties would accept.

This case is probably the most straightforward of all. Irrespective of the value of λ , the principal’s cost advantage implies that it is always optimal to allocate the project to the principal instead of the agent.²⁵⁶ This intuition immediately gives rise to the following proposition:

256. From a joint-wealth perspective ($\lambda = 1$), the principal is the optimal recipient of the project since she enjoys an absolute advantage over the agent. Moreover, from a shareholder-wealth perspective ($\lambda < 1$), the principal would still rather produce, since production by the principal creates greater rents to begin with.

Proposition 3.3: *Suppose $\beta - 1 < \alpha - (1 - c_A) < \alpha + (1 - c_A) < \beta + 1$. The optimal contract is given by $\{p^*(\theta), w^*(\theta), D^*\}$, where*

$$\begin{aligned} p^*(\theta) &= 0 \forall \theta \in \Theta; \\ w^*(\theta) &= \underline{\mu} \forall \theta \in \Theta; \\ D^* &\geq \underline{D} \equiv 1 - C_A(\alpha) = 1 - c_A. \end{aligned}$$

In other words, when the principal's profitable domain completely nests the agent's, the optimal contract never transfers production authority to the agent. Rather, B withholds authority for all projects, and A receives a wage equal to his reservation payoff. Because the principal has an absolute cost advantage, the contract, while restrictive towards the agent, is also the first-best efficient contract. Consequently, in the case of complete overlap, the optimal private-information contract necessarily coincides with the optimal complete-information contract. Both prescribe absolute deterrence of the fiduciary and production by the principal for every project that is profitable to her.

