

Godard



NATIONAL AERONAUTICS AND SPACE ADMINISTRATION  
WASHINGTON, D.C. 20546

MAY 1 1974

REPLY TO  
ATTN OF: GP

TO: KSI/Scientific & Technical Information Division  
Attn: Miss Winnie M. Morgan

FROM: GP/Office of Assistant General  
Counsel for Patent Matters

SUBJECT: Announcement of NASA-Owned U.S. Patents in STAR

In accordance with the procedures agreed upon by Code GP and Code KSI, the attached NASA-owned U.S. Patent is being forwarded for abstracting and announcement in NASA STAR.

The following information is provided:

U.S. Patent No. : 3,805,266  
Government or Corporate Employee : Ball Brothers Research Corp. Boulder, CO.

Supplementary Corporate Source (if applicable) : [wavy line]

NASA Patent Case No. : FSC-11,428-1

NOTE - If this patent covers an invention made by a corporate employee of a NASA Contractor, the following is applicable:

YES  NO

Pursuant to Section 305(a) of the National Aeronautics and Space Act, the name of the Administrator of NASA appears on the first page of the patent; however, the name of the actual inventor (author) appears at the heading of column No. 1 of the Specification, following the words "in respect to an invention of ..."

*Bonnie L. Woerner*  
Bonnie L. Woerner  
Enclosure

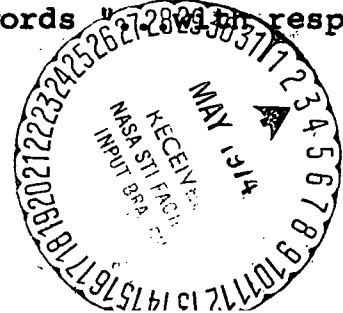

[54] TURNSTILE SLOT ANTENNA

[76] Inventors: **James C. Fletcher**, Administrator of the National Aeronautics and space Administration with respect to an invention of; **Robert E. Munson**, Salt Lake City, Utah

Primary Examiner—Eli Lieberman  
Attorney, Agent, or Firm—R. F. Kempf; John R. Manning

[22] Filed: **Sept. 27, 1972**

[21] Appl. No.: **292,685**

[57] **ABSTRACT**

A novel turnstile slot antenna is disclosed, the antenna being for and integral with a spacecraft having a substantially cylindrical body portion. The antenna comprises a circumferential slot about the periphery of the spacecraft body portion with an annular wave guide cavity defining a radial transmission line disposed within the spacecraft body portion behind and in communication with the circumferential slot. Feed stubs and associated transmission apparatus are provided to excite the annular cavity in quadrature phase such that an omnidirectional, circularly polarized, rotating radiation pattern is generated. The antenna of the instant invention has utility both as a transmitting and receiving device, and ensures continuous telemetry and command coverage with the spacecraft.

[52] U.S. Cl. .... **343/708, 343/769, 343/853**  
[51] Int. Cl. .... **H01q 1/28**  
[58] Field of Search ..... **343/DIG. 2, 705, 708, 769, 343/853**

[56] **References Cited**  
**UNITED STATES PATENTS**

3,226,720	12/1965	Brunner et al. ....	343/708
3,182,326	5/1965	Cutler .....	343/DIG. 2
3,005,986	10/1961	Reed .....	343/708
3,710,338	1/1973	Munson .....	343/708

7 Claims, 3 Drawing Figures

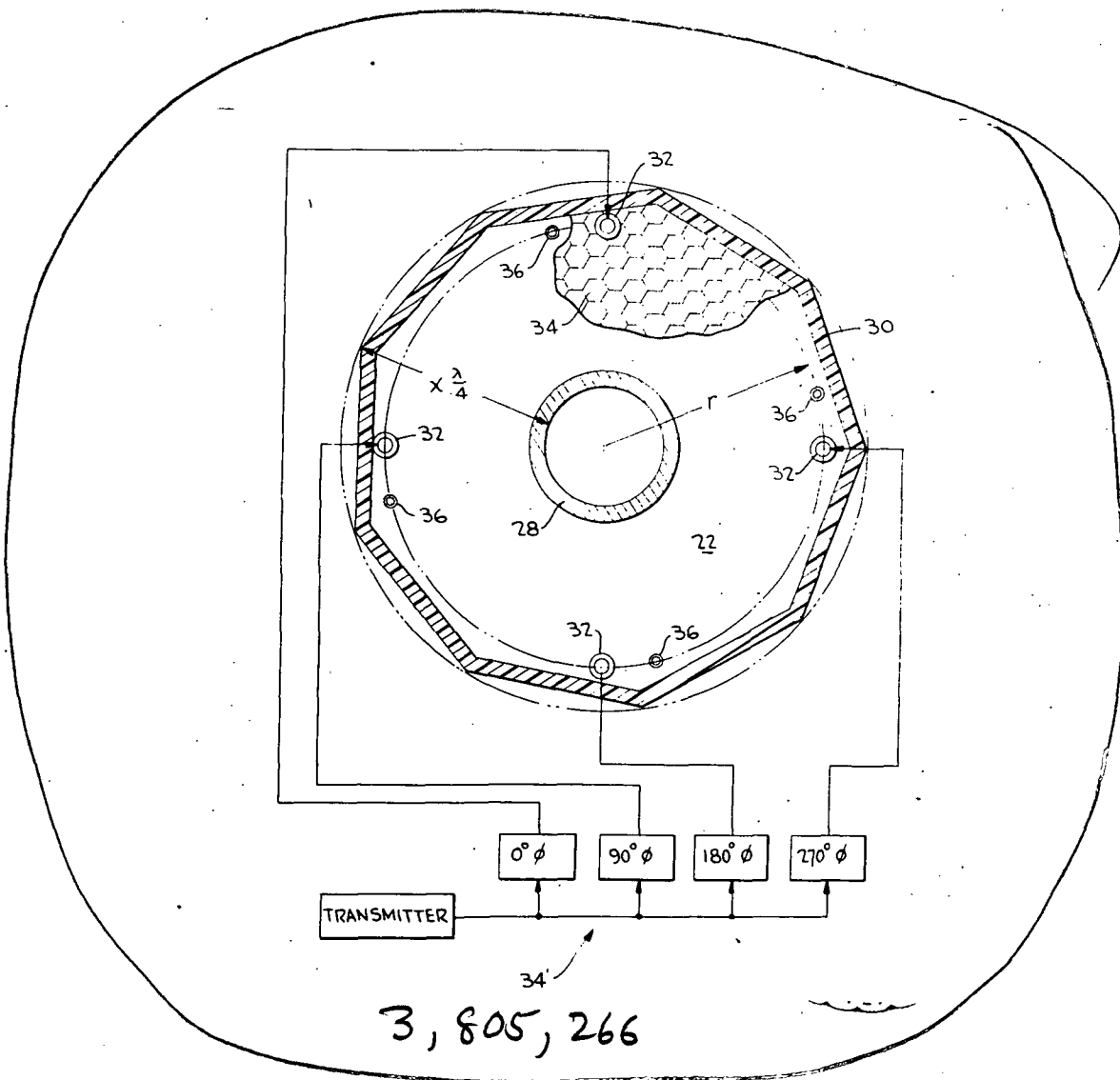

(NASA-Case-GSC-11428-1) TURNSTILE SLOT  
 ANTENNA Patent (NASA) 5 P CSCI 17B

00/09

Unclas  
36394

N74-20864

FIG. 2

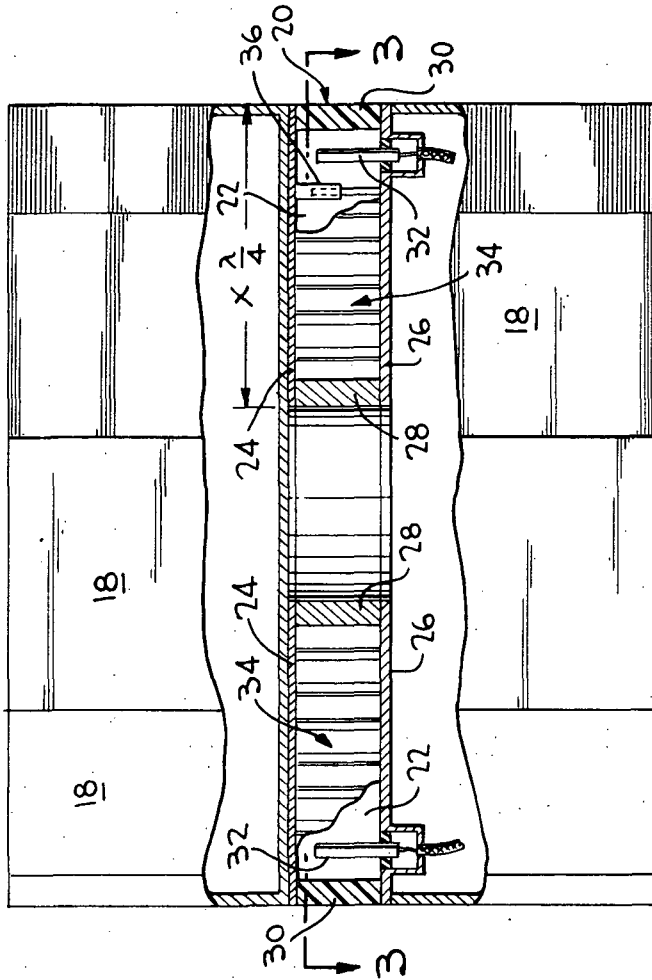
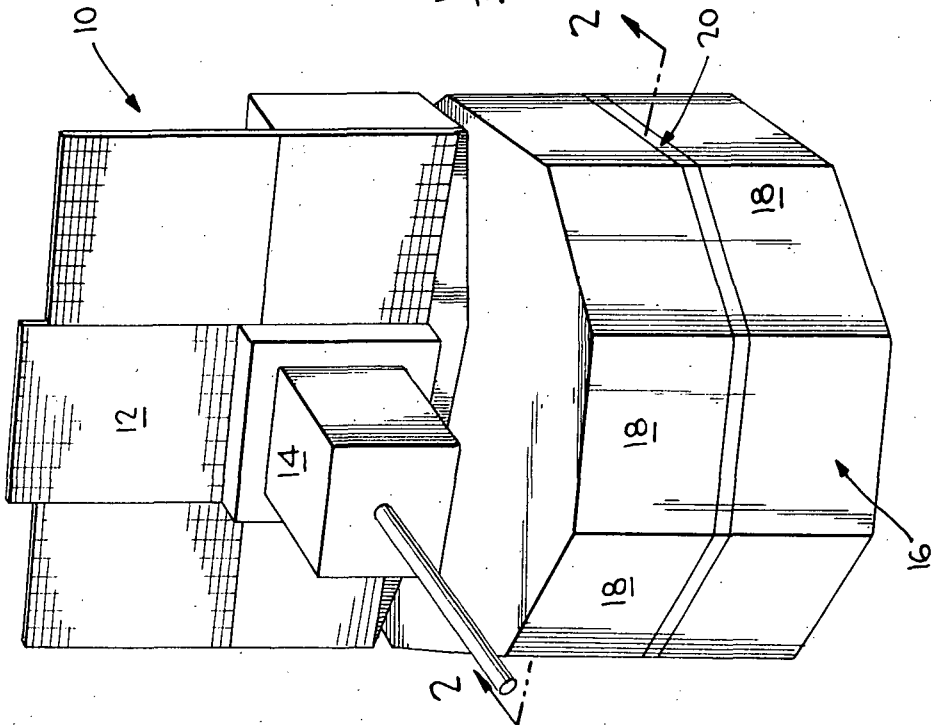
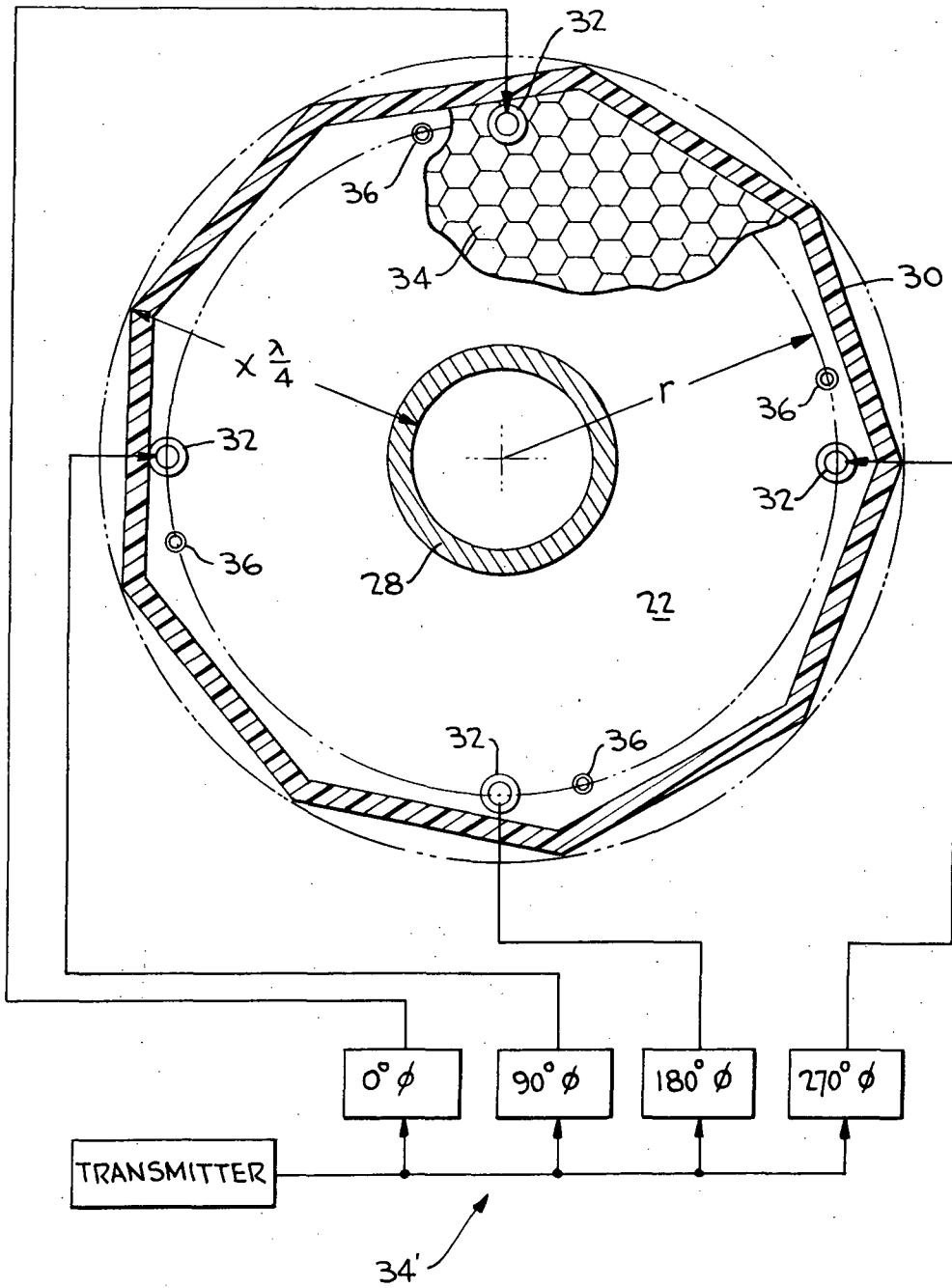

FIG. 1



SHEET 2 OF 2

FIG. 3



## TURNSTILE SLOT ANTENNA ORIGIN OF THE INVENTION

The invention described herein was made in the performance of work under a NASA contract and is subject to the provisions of Section 305 of the National Aeronautics and Space Act of 1958, Public Law 85-568 (72 STAT. 435; 42 USC 2457).

### BACKGROUND OF THE INVENTION

This invention generally relates to antenna systems and particularly concerns an antenna system for and integral with spacecraft or missiles so as to ensure telemetry and command coverage.

Difficulties are oftentimes encountered in effecting acceptable communication between ground tracking or command stations and missiles or other spacecraft during flight. In this respect, the spin rate associated with such spacecraft vehicles, as well as the trajectory or flight path, are such that the spacecraft or vehicle presents different angles of orientation at different times with respect to the ground tracking and/or command post. These constant changes in relative orientation of the vehicle in flight poses extreme demands on the spacecraft antenna system, which system must be capable of both receiving and sending radio information during all different physical orientations of the spacecraft, i.e., through all possible "look angles."

Prior art spacecraft antenna structures generally have not satisfied these stringent requirements. For example, the type of radiation pattern required is omnidirectional and, from the standpoint of electromagnetic theory, the type of antenna necessary to generate this requisite omnidirectional pattern is what is termed a "turnstile" antenna which, in its classic physical embodiment, comprises two mutually perpendicular dipoles fed 90° out-of-phase. In addition to an omnidirectional power pattern coverage, the classic turnstile antenna, in theory, provides circular field polarization, a zero decibel roll pattern variation, and no roll polarization, all these attributes being extremely useful in spacecraft communication. Yet, the classic turnstile antenna does not live up to its promise in that it does not maintain theoretical operation when on or in close proximity to a spacecraft.

### BRIEF SUMMARY OF THE INVENTION

It is therefore apparent that a need exists for an antenna structure which, during operation on a spacecraft, provides actual radiation patterns approximating those to be expected from a classic turnstile antenna array. It is the primary objective of the instant invention to provide such a novel antenna structure.

It is a further objective of the instant invention to provide a novel turnstile slot antenna which is integral with the spacecraft structure whereby the spacecraft structure facilitates generation of the desired radiation pattern, rather than deleteriously affecting same.

It is still another objective of the instant invention to provide an antenna structure or assembly which generates a substantially omnidirectional radiation pattern whereby continuous telemetry and command coverage can be effected.

It is still another objective of the instant invention to provide a spacecraft antenna assembly which does not exhibit rapid polarization switching due to vehicle spin.

A further objective of the instant invention concerns the provision of a novel antenna structure providing high gain at substantially all "look angles."

Yet another objective of the instant invention concerns the provision of a novel spacecraft or missile turnstile antenna which generates an extremely smooth power radiation pattern.

These objectives, as well as others which will become apparent as the description proceeds, are implemented by the novel invention which, as afore-stated, comprises a turnstile slot antenna of novel construction, the antenna being for and integral with a spacecraft having a substantially cylindrical body portion. In the preferred inventive embodiment, the antenna comprises a circumferential slot about the periphery of the spacecraft body portion with an annular wave guide cavity defining a radial transmission line disposed within the spacecraft body portion behind and in communication with the circumferential slot. In the preferred inventive embodiment, the annular wave guide cavity has a shorted innermost wall and is constructed to have an electrical length of approximately one-quarter the wave length of the excitation frequency. The annular cavity of the antenna is excited in quadrature phase by virtue of four feed stubs equally spaced about the circumference of the cavity and just inside the circumferential slot. With this placement of the feed stub, the short circuit defined by the innermost wall of the cavity is electrically transformed to an open circuit whereby radiation is generated outwardly through the circumferential slot. Specifically, it will be seen that the radiation pattern generated is omnidirectional, circularly polarized, and defines a rotating field.

In the preferred inventive embodiment, the annular cavity is filled with a dielectric plastic honeycomb structure for strength, and the circumferential slot itself may be physically closed with a Teflon plug or seal. Tuning of the novel antenna of the instant invention is effected by the placement of a matching or tuning stub adjacent each of the feed stubs within the annular cavity.

### BRIEF DESCRIPTION OF THE DRAWINGS

The invention itself will be better understood, and features and advantages thereof in addition to those above-described, will become apparent from the following detailed description of the preferred inventive embodiment, such description making reference to the appended sheets of drawings, wherein:

FIG. 1 is a perspective illustration of a typical spacecraft or other vehicle employing the turnstile slot antenna of the instant invention as an integral part thereof;

FIG. 2 is an elevational view of the turnstile slot antenna of the instant invention, partially in section for illustrative clarity, taken along lines 2—2 of FIG. 1; and

FIG. 3 is a top plan view of the turnstile slot antenna of the instant invention taken along lines 3—3 of FIG. 3, and further schematically illustrating the electrical feed means utilized therewith to excite the antenna with quadrature phase.

### DETAILED DESCRIPTION OF A PREFERRED INVENTIVE EMBODIMENT

Referring now to the drawings, and particularly to FIG. 1 thereof, the integral construction of the turnstile

slot antenna of the instant invention with a typical spacecraft having a substantially cylindrical body portion is shown. The spacecraft generally designated by reference numeral 10 may comprise an orbiting satellite such as the so-called "H-model orbiting solar observatory satellite." The spacecraft will be seen to typically include a plurality of solar cell panels 12, an instrument package 14, and a skirt sub-assembly or substantially cylindrical body portion 16. In the illustrated embodiment, body portion 16, while substantially cylindrical, is constructed as a polygon having a plurality of flat panels 18, as shown.

A circumferential slot generally designated by reference numeral 20 is disposed about the periphery of the substantially cylindrical spacecraft body portion 16, this circumferential slot being filled, for example, with a dielectric material such as plastic and defining the radiation surface through which the radiation pattern of the novel antenna is generated.

Referring now to FIGS. 2 and 3 of the appended drawings, the detailed construction of the turnstile slot antenna of the instant invention can be seen. Specifically, an annular wave guide cavity designated by reference numeral 22 and defining a radial transmission line is disposed within the spacecraft body portion 16 behind and in communication with the circumferential slot 20. The upper and lower walls, 24 and 26, respectively, of the annular wave guide cavity 22 are constructed of a thin sheet of metal, and it should be noted that the innermost wall or "hub" comprises a circular metallic disc 28 defining an electrical short circuit. As discussed above, the outermost wall of the annular cavity 22 is defined by the circumferential slot about the periphery of the spacecraft body portion 16 any may be filled with a plastic dielectric material such as is indicated at reference numeral 30.

The novel antenna of the instant invention includes a mean to excite the annular cavity 22 in quadrature phase and, to this end, four equally spaced electrical feed stubs 32 are disposed about the circumference of the annular cavity 22 just inside the circumferential slot 20, each feed stub 32 being excited in quadrature phase such as with the schematically illustrated transmitter and phase-shifting apparatus shown in FIG. 3, and designated by reference numeral 34'. In the preferred inventive embodiment, a dielectric honeycomb filler designated by reference numeral 34 is disposed throughout the annular cavity 22 so as to provide strength, and the like. The preferred inventive embodiment of the novel antenna will be seen to further include a tuning stub 36 disposed in the annular cavity 22 adjacent each feed stub. The tuning stub 36 provides a capacitive coupling between the upper and lower walls 24 and 26, respectively, of the annular wave guide cavity 22. Each of the tuning stubs 36 and feed stubs 32 are preferably disposed at an equal radius from the center or "hub" of the annular cavity 22 and, in the preferred inventive embodiment, annular cavity 22 is contemplated to have a length or radial dimension approximating one-quarter wave length of the excitation frequency. With this construction, the electrical short circuit provided by the metal disc 28 at the innermost wall of the annular cavity 22 is electrically transformed to an open circuit,

thus ensuring outward radiation through the circumferential slot 20.

In operation of the novel turnstile slot antenna as above-described, an omnidirectional, circularly polarized, rotating radiation pattern is generated in an outward direction, the electric field E of the generated radiation pattern being oriented in a direction parallel to the cylindrical axis of the spacecraft body portion. Since the radiation pattern is omnidirectional in the form of a sphere, telecommunication between the ground station and the spacecraft can readily and continuously be effected, regardless of spacecraft orientation, and regardless of spin of the spacecraft.

From the foregoing detailed description, it should therefore be apparent that all the objectives set forth at the outset of this specification have been successfully achieved. Moreover, while there has been shown and described a present preferred embodiment of the invention, it is to be distinctly understood by those skilled in the art that the invention is not limited thereto, but may otherwise be variously embodied and practiced within the scope of the following claims. Accordingly,

What is claimed is:

1. A turnstile slot antenna for and integral with a spacecraft having a substantially cylindrical body portion, said antenna comprising a continuous circumferential slot about the periphery of said spacecraft body portion, an annular wave guide cavity defining a continuous radial transmission line disposed within said spacecraft body portion aligned radially within said circumferential slot and in communication with said circumferential slot and having a coaxial width no greater than the coaxial width of said circumferential slot, the depth of the cavity being greater than the width and means to excite said annular cavity in quadrature phase comprising four electrical feed stubs equally spaced about the circumference of said annular cavity inside said circumferential slot and projecting from a sidewall thereof, whereby an omnidirectional circularly polarized rotating radiation pattern is generated.

2. An antenna as defined in claim 1, wherein the electrical length of said annular cavity from circumferential slot to the innermost wall of the annular cavity approximates one-quarter wave length of the excitation frequency, the innermost wall of the cavity defining an electrical short circuit.

3. An antenna as defined in claim 2, further including a dielectric honeycomb filler disposed throughout said annular cavity.

4. An antenna as defined in claim 3, wherein said filler is constructed of plastic material.

5. An antenna as defined in claim 2, further including a tuning stub disposed in said annular cavity adjacent each feed stub.

6. An antenna as defined in claim 5, wherein each said tuning stub is capacitive.

7. An antenna as defined in claim 1, wherein the electric field E of the generated radiation pattern is oriented in a direction parallel to the cylindrical axis of the spacecraft body portion.

\* \* \* \* \*