

NASA/CR—2003-212309



Ultra-Efficient Engine Diameter Study

David L. Daggett, Stephen T. Brown, and Ron T. Kawai
Boeing Commercial Airplane Group, Seattle, Washington

May 2003

The NASA STI Program Office . . . in Profile

Since its founding, NASA has been dedicated to the advancement of aeronautics and space science. The NASA Scientific and Technical Information (STI) Program Office plays a key part in helping NASA maintain this important role.

The NASA STI Program Office is operated by Langley Research Center, the Lead Center for NASA's scientific and technical information. The NASA STI Program Office provides access to the NASA STI Database, the largest collection of aeronautical and space science STI in the world. The Program Office is also NASA's institutional mechanism for disseminating the results of its research and development activities. These results are published by NASA in the NASA STI Report Series, which includes the following report types:

- **TECHNICAL PUBLICATION.** Reports of completed research or a major significant phase of research that present the results of NASA programs and include extensive data or theoretical analysis. Includes compilations of significant scientific and technical data and information deemed to be of continuing reference value. NASA's counterpart of peer-reviewed formal professional papers but has less stringent limitations on manuscript length and extent of graphic presentations.
- **TECHNICAL MEMORANDUM.** Scientific and technical findings that are preliminary or of specialized interest, e.g., quick release reports, working papers, and bibliographies that contain minimal annotation. Does not contain extensive analysis.
- **CONTRACTOR REPORT.** Scientific and technical findings by NASA-sponsored contractors and grantees.

- **CONFERENCE PUBLICATION.** Collected papers from scientific and technical conferences, symposia, seminars, or other meetings sponsored or cosponsored by NASA.
- **SPECIAL PUBLICATION.** Scientific, technical, or historical information from NASA programs, projects, and missions, often concerned with subjects having substantial public interest.
- **TECHNICAL TRANSLATION.** English-language translations of foreign scientific and technical material pertinent to NASA's mission.

Specialized services that complement the STI Program Office's diverse offerings include creating custom thesauri, building customized databases, organizing and publishing research results . . . even providing videos.

For more information about the NASA STI Program Office, see the following:

- Access the NASA STI Program Home Page at <http://www.sti.nasa.gov>
- E-mail your question via the Internet to help@sti.nasa.gov
- Fax your question to the NASA Access Help Desk at 301-621-0134
- Telephone the NASA Access Help Desk at 301-621-0390
- Write to:
NASA Access Help Desk
NASA Center for Aerospace Information
7121 Standard Drive
Hanover, MD 21076

NASA/CR—2003-212309

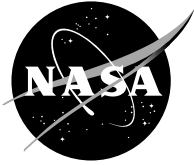

Ultra-Efficient Engine Diameter Study

David L. Daggett, Stephen T. Brown, and Ron T. Kawai
Boeing Commercial Airplane Group, Seattle, Washington

Prepared under Contract NAS3-01140, Task 10

National Aeronautics and
Space Administration

Glenn Research Center

May 2003

Acknowledgments

This document summarizes the efforts of many participants, all of whom were essential to the successful evaluation of Ultra-Efficient Engine Technology as applied to future technology airplanes. The authors gratefully acknowledge the contributions of both the Boeing Commercial Airplane (BCA) group and the Phantom Works, Huntington Beach (PWHB) groups.

Program Manager	Jan Syberg
Program Administration	Mahmood Naimi
Study Lead	David Daggett
Configuration and BCA Lead	Stephen Brown
Phantom Works Lead	Ron Kawai
BCA/Tuskegee study	Tamaira Ross
BCA:	
Aerodynamics	
High Speed	Nick Ferraiolo/Kevin Finke
Aero Low Speed	Frank Payne
Aero Performance	Gnanulan Canagaratna
Propulsion	Don Rupchock
Structures	Jan Kordel
Weights	Andrew Ouellette
Engine Pod Weight	Jerry Salmon
Noise	Gerald Folken
Emissions	David Daggett
Engine Integration	Mike Kass
PWHB:	
Aero Performance	Alan Okazaki
Weights	Anthony Gonzales
Aero Modeling	Peter Camacho
Engine Performance	Doug Krueger
Propulsion Modeling	Jim McComb

Contents were reproduced from author-provided presentation materials.

Available from

NASA Center for Aerospace Information
7121 Standard Drive
Hanover, MD 21076

National Technical Information Service
5285 Port Royal Road
Springfield, VA 22100

Available electronically at <http://gltrs.grc.nasa.gov>

TABLE OF CONTENTS

EXECUTIVE SUMMARY	v
GLOSSARY	vii
1.0 INTRODUCTION	1
1.1 Background and reason for the study	1
1.2 Work statement	3
1.3 Groundrules	5
2.0 AIRCRAFT AND UEET POWERPLANT DESCRIPTIONS	6
2.1 Parent Airplane (model 777-200ER)	6
2.2 Baseline Study Airplane	7
2.3 UEET Powerplant Descriptions	8
2.3.1 GE Engines	8
2.3.2 P&W UEET Powerplants	10
3.0 DESIGN ANALYSIS	13
3.1 Performance	13
3.2 Drag	15
3.3 Weight	21
3.3.1 Engine weights assessments	21
3.3.2 Nacelle weights assessments	23
3.4 Integration	24
3.5 Operating Cost	26
3.6 Noise	27
3.7 Emissions	31
4.0 OPTIMAL CONFIGURATIONS	35
4.1 Engine/Airframe Sizing	35
4.2 P&W powered airplane	37
4.3 GE powered airplane	44
4.4 Optimal BPR for larger and smaller airframes	46
4.4.1 Smaller Aircraft BPR drivers	47
4.3.2 Larger Aircraft BPR drivers	48
5.0 CONCLUSION	50
REFERENCES	52

EXECUTIVE SUMMARY

The objective of this task order was to integrate and assess the performance of three General Electric (GE) powerplants and three Pratt & Whitney (P&W) powerplants of varying Bypass Ratio (BPR), fan diameter, and engine technology on an advanced technology study airplane (Figure i). The performance evaluation included the assessment of the overall airplane system attributes including weight, drag, noise, emissions, mission fuel use and operating cost. The results showed Ultra-Efficient Engine Technology (UEET) powerplants installed in airframes, resized to benefit from the reduced specific fuel consumption (SFC) and weight, could lead to fuel use reductions of close to 16%.

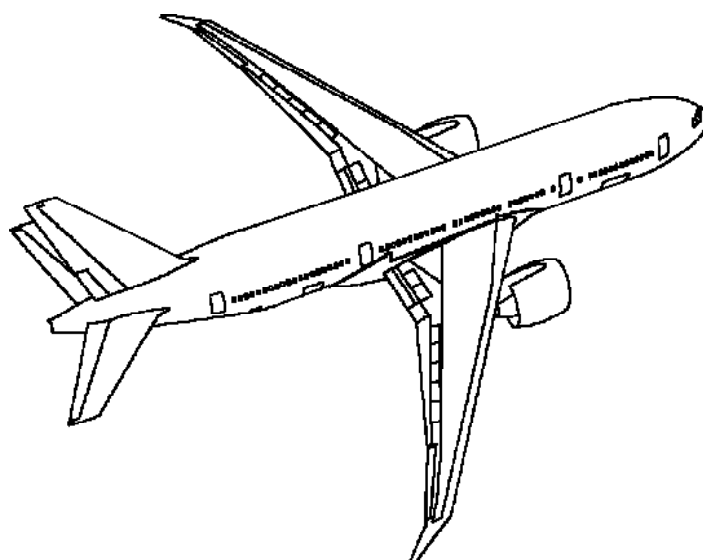

Figure i. UEET Engines and Composite wing integrated on the 777-200ER

The study results showed that the engines with the highest BPR exhibited the best specific fuel consumption. However, when the engines were sized for the aircraft, and installation effects accounted for, the moderate BPR engines achieved the lowest overall fuel consumption and operating cost.

For the GE UEET powerplants, the optimal BPR was found to be 11—about half way between their largest BPR engine of 14 and the medium BPR engine of 9.5. For the P&W UEET powerplants, the optimal engine providing the lowest fuel use and cost was a BPR of 14.3. The P&W UEET engine achieved better fuel efficiency improvement over the baseline PW4090 engine when compared to the GE UEET engine over the GE90-94B baseline engine (Figure ii). In terms of absolute mission fuel use, the optimal P&W UEET powered airplane achieved approximately 2% better fuel efficiency than the best GE UEET powered airplane.

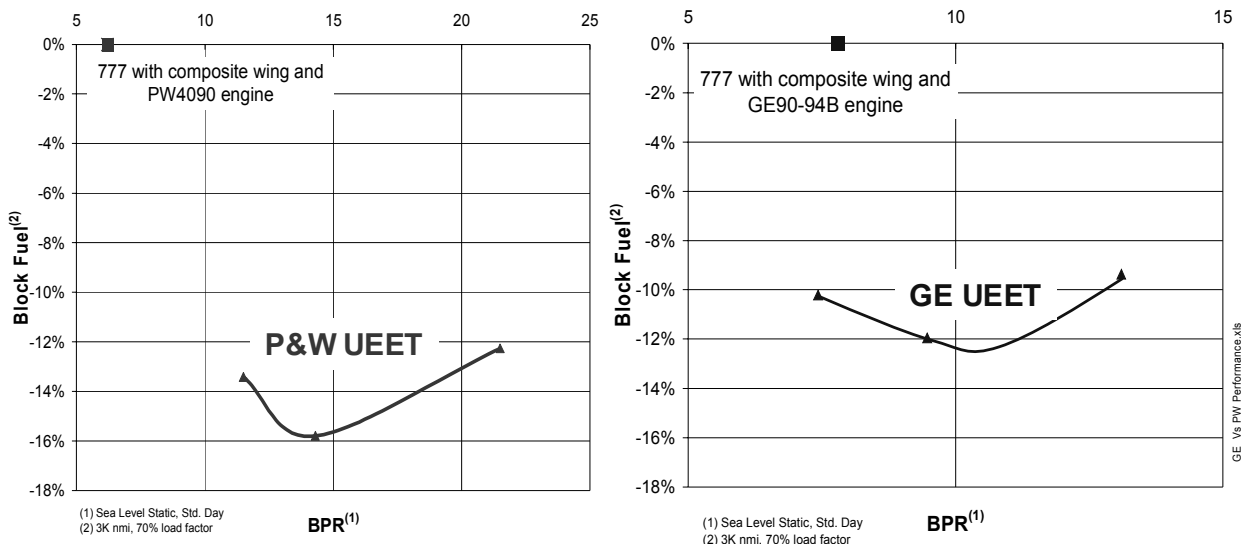

Figure ii. Block fuel use for P&W and GE UEET powerplants

However, the optimal P&W engine also weighed more than the optimal GE engine. Since the airplane operating cost accounting methodology uses airplane weight in its calculation, the heavier P&W engine was penalized and ended up with the same operating cost as the lighter weight, but less fuel efficient, GE engine as shown in Figure iii below.

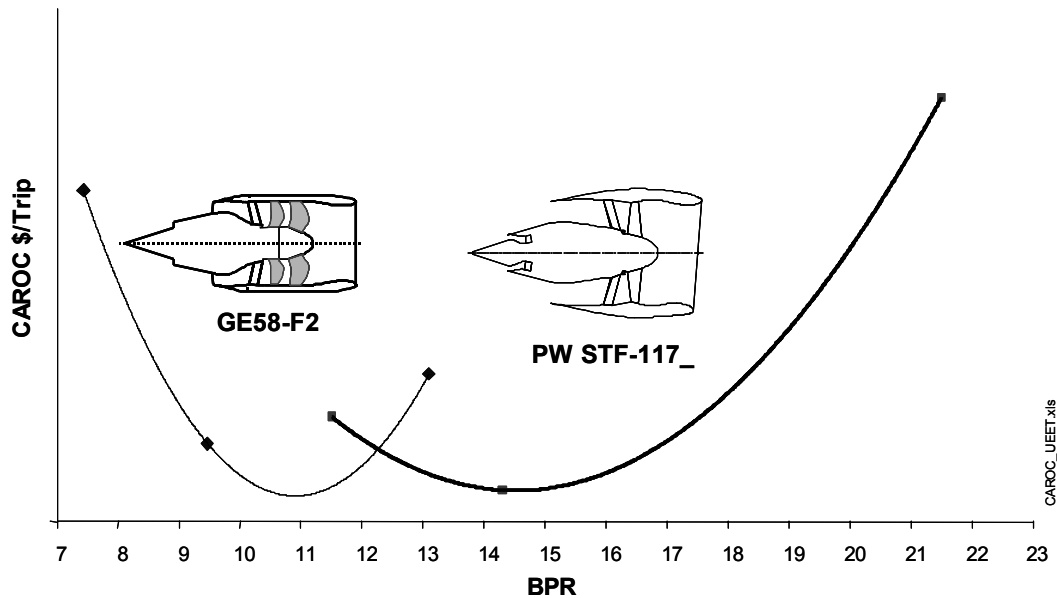

Figure iii. Cash Airplane Related Operating Cost for UEET powerplants

A subcontract study performed by Tuskegee University concluded that the BPR versus block fuel efficiency trend found for the 777-sized airplane followed for airplanes of smaller and larger passenger counts.

GLOSSARY

A_n	Area, new
AR	Aspect Ratio
ATF	Advanced Technology Fan
ATN	Advanced Technology Nacelle
BPR	Bypass Ratio
CAEP	ICAO Committee on Aviation Environmental Protection
CAROC	Cash Airplane Related Operating Costs
CO	Carbon Monoxide
CFR	United States Code of Federal Regulations
Cts	Counts
D	Diameter
DP/Foo	Total Landing Takeoff Cycle Emissions/Takeoff Thrust
EI_{NOx}	Emissions index for NO _x given as grams of NO _x /Kg fuel
ETOPS	Extended-Range Twin-Engine Operations
FAR	Federal Aviation Regulation
FPR	Fan Pressure Ratio
GCASES	Graphical Computer Aided Sizing and Optimization System
GE	General Electric
GTF	Geared Turbofan
HC	Hydro-Carbons
ICAO	International Civil Aviation Organization
in	inch
kg	kilogram
kts	nautical miles per hour
lb	pound
L	Length
L/D	Lift/Drag Ratio
Load Factor	Percentage of an airplane's seat capacity occupied by passengers
LTO	Landing Take-Off cycle
LPT	Low Pressure Turbine
max	Maximum
min	Minimum
MTOW	Maximum Take-Off Weight
M_{crit}	Mach Number for .002 Cd increase over Cd in incompressible flow.
MLW	Maximum Landing Weight

NASA	National Aeronautics and Space Administration (USA)
NOx	Nitrogen Oxides
NMI	Nautical mile
OPR	Overall Pressure Ratio
OEW	Operating Empty Weight
RASER	Revolutionary Aero Space Engine Research
RQL	Rich-Burn, Quick-Quench, Lean-Burn
P&W	Pratt & Whitney
PAX	Passengers
SLST	Sea Level Static Thrust
sqft	square feet
st-mi	Statute Mile
std	Standard
SFC	Specific Fuel Consumption
T_n	Thrust, new
TIES	Technology Identification and Evaluation Selection
TMAT	Technology Metrics Assessment and Tracking
TOGW	Take Off Gross Weight
T/R	Thrust Reverser
T/W	Thrust to Weight Ratio
UEET	Ultra-Efficient Engine Technology
V_{tail}	Volume, Tail
VAN	Variable Area Nozzle
V_{mc}	Velocity, minimum controllable
W_{to}	Weight, Take off
WBS	Work Breakdown Structure

1.0 INTRODUCTION

Engine fan diameter and Bypass Ratio (BPR) optimization studies have been conducted since the beginning of the turbofan age with the recognition that reducing the engine core jet velocity and increasing fan mass flow rate generally increases propulsive efficiency. However, performance tradeoffs limit the amount of fan flow achievable without reducing airplane efficiency.

This study identifies the optimum engine fan diameter and BPR, given the advanced Ultra-Efficient Engine Technology (UEET) powerplant efficiencies, for use on an advanced subsonic airframe. Engine diameter studies have historically focused on specific engine size options, and were limited by existing technology and transportation infrastructure (e.g. ability to fit bare engines through aircraft doors and into cargo holds). This study is unique in defining the optimum fan diameter and drivers for future 2015 (UEET) powerplants while not limiting engine fan diameter by external constraints. This report follows on to a study identifying the system integration issues of UEET engines⁽²⁾.

This Engine Diameter study was managed by Boeing Phantom Works, Seattle, through the NASA Glenn Revolutionary Aero Space Engine Research (RASER) contract under task order #10. Boeing Phantom Works, Huntington Beach, completed the engine/airplane sizing optimization, while the Boeing Commercial Airplane group (BCA) provided design oversight. A separate sub-contract to support the overall project was issued to Tuskegee University.

1.1 Background and reason for the study

As engine fan diameter is increased, the ratio of air moving around the outside of the engine core increases as compared to the amount moving through the core. This ratio is defined as the engine bypass ratio. For a constant thrust (F), as the mass (m) of bypass air increases, the acceleration of air (a) and hence Fan Pressure Ratio (FPR) must decrease to maintain the constant thrust level ($F=ma$). An inverse relationship between BPR and FPR exists as shown in Figure 1.1.

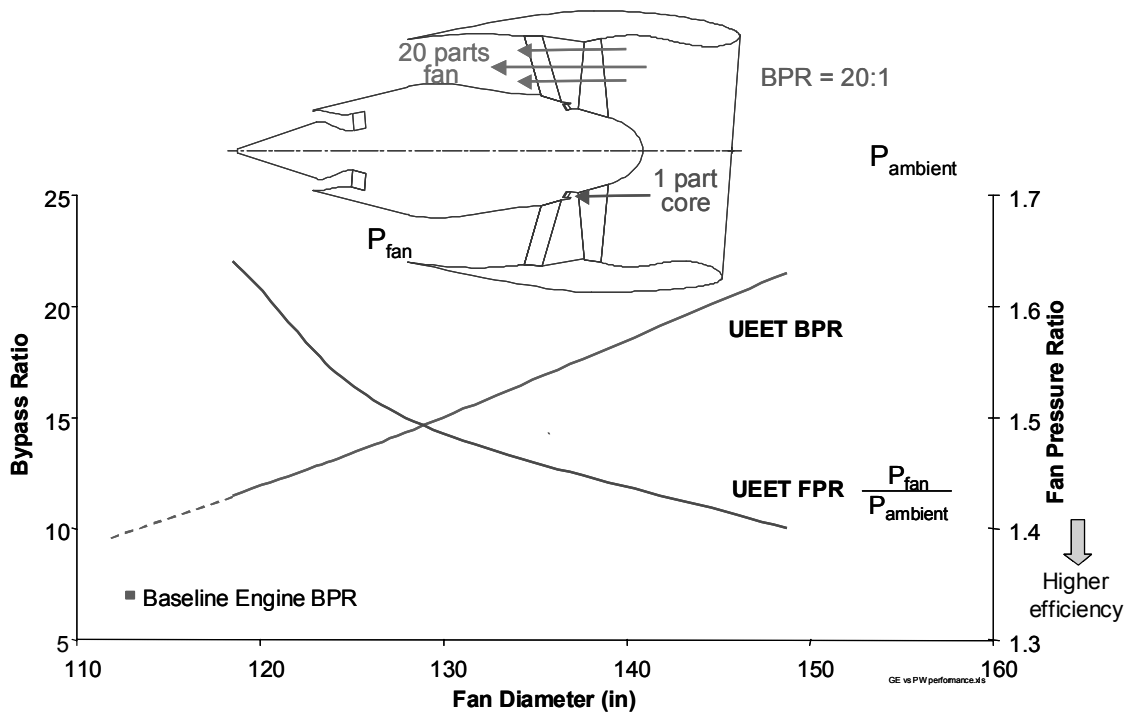

Figure 1.1. BPR and FPR relationship to engine fan diameter

Engine manufacturers are driven to increase BPR since specific fuel consumption (SFC) and noise are typically both driven down (improved) with increasing BPR levels. The theoretical minimum SFC for an ideal turbofan would include an infinite BPR⁽¹⁰⁾. However, as BPR is increased, engine drag, loads, structural integration difficulty and weight are also driven up (reduced performance). Increasing BPR also increases the thrust available from a fixed core size. This inverse relationship is illustrated in Figure 1.2.

During the course of a previous system integration study⁽²⁾ it was found that some of the P&W UEET engines provided for the future airplane were not optimally sized in that they had too high of a BPR. In a different system integration study to evaluate the benefits of a slotted wing with UEET powerplants, it was observed that the UEET powerplant supplied by GE was also not optimally sized in that it had too small of a BPR. Thus, it was determined that an engine diameter (i.e. BPR) study was necessary to find a BPR that was just right. The optimal BPR for each manufacturer would most likely vary with the technology type and advancement level. In addition, this study would help guide the engine manufacturers to focus their development on the technologies providing the best return on investment.

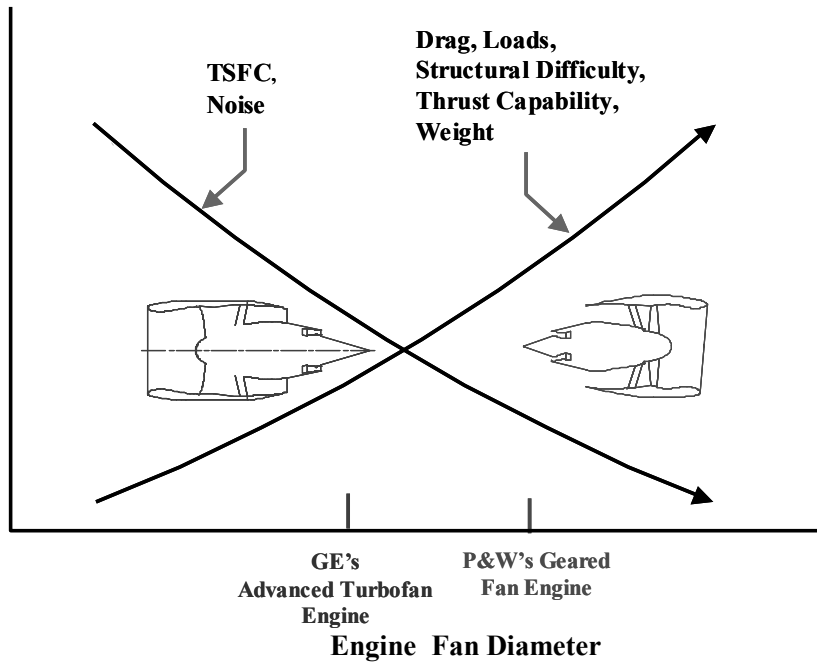

Figure 1.2. BPR trades and previous UEET engines supplied

1.2 Work statement

The objective of this NASA UEET study was to quantify the airplane system-level impacts of UEET engines on future airframes. The statement of work specified that a 0.85 Mach advanced technology study airplane from a previous NASA study be used as the platform to evaluate three differently sized BPR engines from GE and three differently sized BPR engines from P&W as shown in Figure 1.3.

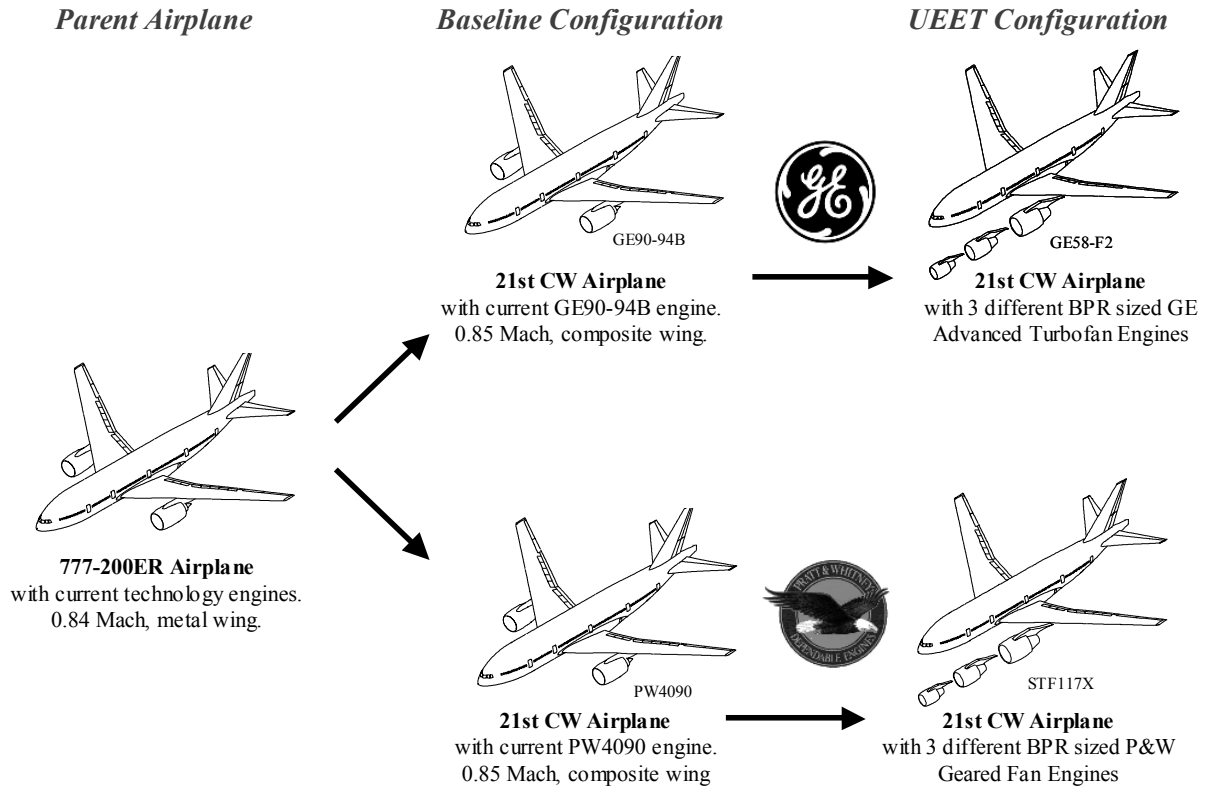

Figure 1.3. Study Airplanes and UEET Powerplants to be evaluated

The project was divided into 5 major work items.

1. Establish the Baseline Airplane. Design, and obtain performance metrics for an advanced, future technology (i.e. 2015) airplane with current technology engines.
2. Integrate GE's Advanced Turbofan UEET Powerplants. Obtain 3 different bypass ratio UEET study engines from GE and optimize the baseline airplane for each engine. Provide the incremental change in performance (cruise and takeoff/landing), noise, emissions and Direct Operating Cost (DOC) drivers between the baseline and each of the 3 airplanes.
3. Integrate P&W's Direct drive and Geared Fan Engines. Obtain 3 different bypass ratio UEET study engines from P&W and integrate these onto the advanced technology airplane, as described above with GE engines.
4. Optimum sizing configuration & environmental impact assessment. Using the results from work items 2 and 3 above, discuss the pros and cons of each configuration, and when warranted, recognize the superior configuration.
5. Airplane size sensitivity. A subcontract was issued to Tuskegee University for a design sensitivity study of airplane size versus engine SFC and installation performance tradeoffs. A small 737-sized airplane and larger 747-sized future technology airplanes were to be evaluated with generic advanced technology engines similar to the UEET powerplants.

1.3 Groundrules

Since this study builds on the earlier UEET systems integration assessments, it used a similar set of ground rules to be consistent. These are shown in Table 1.1.

Table 1.1. Study ground rules

<u>Technology and Requirements</u>	
Date:	Technology readiness date of 2015
Seating:	Multi-class (70% pax. LF), 305 passengers similar to 777-200ER
Mission Requirements:	Design Payload/Range, Landing, Takeoff field length ICAC & Cruise Speed Comparable to Parent 777-200ER airplane.
Geometry:	Composite wing technology with raked wing tips from 21 st Century Wing study, sizing to maintain engine span location, wing/nacelle gap and a 213ft maximum wingspan gate constraint.
Sizing Variables	Wing Area: Size to mission range and requirements Drag: use windmill, and spillage delta on engine out for V _{mc} vertical tail size delta, second segment climb thrust sizing.
Nacelle Ground Clearance	737 size 18in min, 777 size 28in min per FAA AC150, assuming 5ft min. tire offset from pavement edge.
Optimization measure:	Minimum 3,000 Nmi mission fuel Burn for minimum CAROC
<u>2015 year Goals</u>	
Engine SFC Fuel Use:	-10%
Engine Block Fuel Use:	-8% small aircraft, -15% large aircraft (NASA goal)

LTO Emissions: NO_x = CAEP2 -70% (NASA goal)

Noise: Stage 3 minus 20dB cum., meet QC2 London Departure

2.0 AIRCRAFT AND UEET POWERPLANT DESCRIPTIONS

2.1 Parent Airplane (model 777-200ER)

The parent airplane, that the study baseline airplane is derived from, is a current production (Y2000) 777-200ER with two GE90-94B engines, each producing 94,000 lb of sea level thrust. The Maximum Take Off Weight (MTOW) is 656,000 lb with a cruise speed of 0.84 Mach and maximum range of 7,695 NMI with a maximum fuel capacity of 45,220 US Gallons. Basic dimensions of the 777-200ER used in the study are listed in Figure 2.1 below:

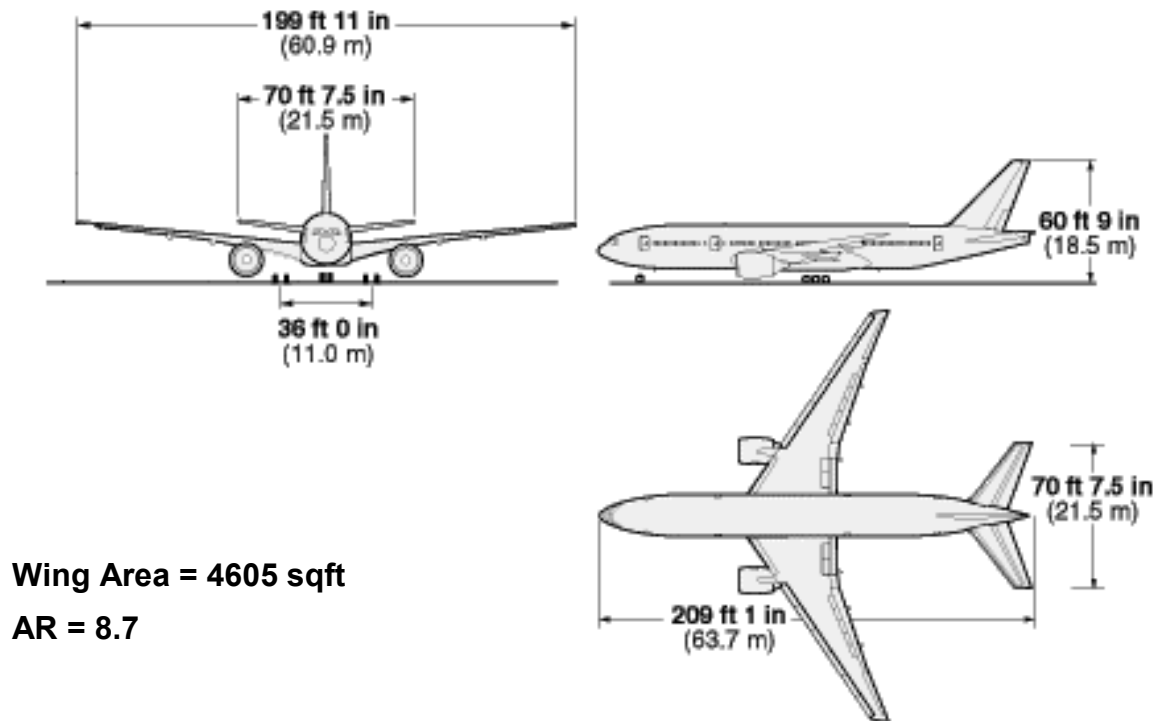

Figure 2.1. 777-200ER basic configuration

The aircraft was configured in a 3-class seating configuration accommodating 305 passengers in a 60in pitch first class, 38in pitch business class and 32in pitch coach arrangement using medium – long range rules as shown in Figure 2.2.

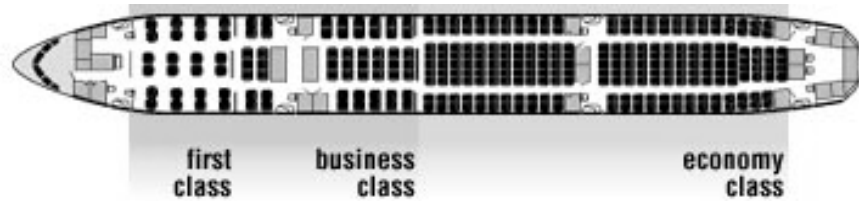

Figure 2.2. 777-200ER seating configuration

2.2 Baseline Study Airplane

The baseline airplane evolved from the parent 777-200ER airplane but was fitted with a new composite wing and a current GE or P&W baseline engine. The wing was defined in a previous airframe integration study. Basic geometry of the composite wing 777-200ER used in the study is shown in Figures 2.3 and 2.4 and 2.5 below. The GE90 engine baseline was de-rated to 88,000lb thrust due to the lighter Operating Empty Weight (OEW) and improved aerodynamics. The PW4090 engine baseline required a throttle push to 92,400lb to provide equivalent top of climb thrust.

This configuration will be defined as 777-Baseline.

Wing Sref = 4367 sqft, AR = 10.2

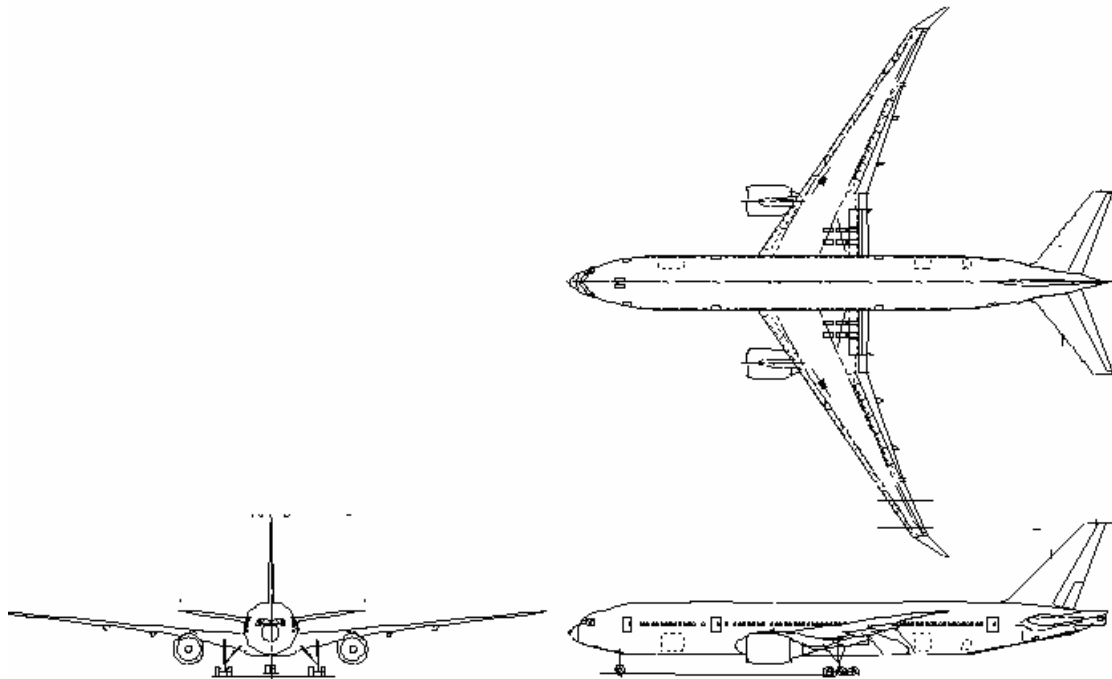

Figure 2.3. Baseline study airplane with composite wing

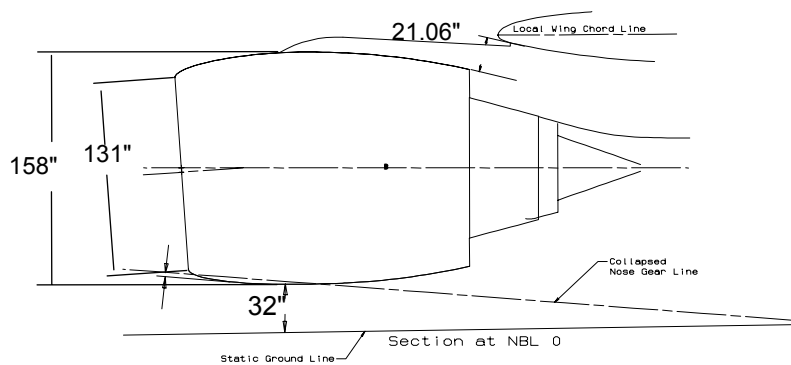

Figure 2.4. GE90-94 engine on baseline airplane

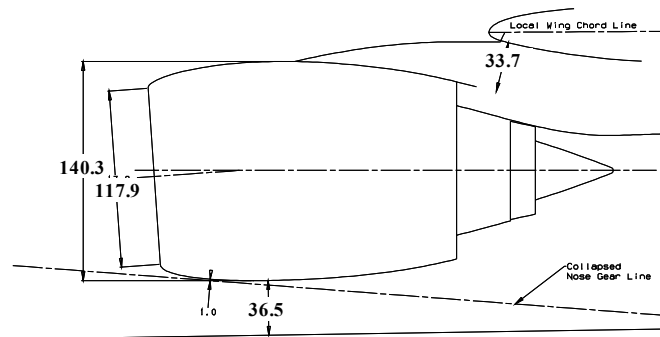

Figure 2.5. PW4094 engine on baseline airplane

2.3 UEET Powerplant Descriptions

The UEET study engines from General Electric and P&W both used advanced technology that is anticipated to be ready in 2015 for design into future production engines.

2.3.1 GE Engines

The General Electric UEET powerplants utilized advanced technology to improve engine fuel efficiency. All three of the GE engines utilized the same technology across the fan diameter range. The primary difference between the P&W powerplants and the GE UEET powerplants was the use of a dual, counter-rotating fan as shown in Figure 2.6.

The smallest diameter, lowest BPR engine (GE58-F2-B7) was designed to have about the same BPR as the current technology baseline GE90-94 engine (7.8 versus 7.43 for the GE90). However, at this BPR, the fan diameter was significantly smaller (100.6in versus 123in for the GE90) albeit at a lower thrust due to the lighter

aircraft weight. Scaling up the GE58-F2-B7 for the same thrust at Mach 0.25 would have a fan diameter of 108in vs 123in.

The medium-sized BPR engine (GE58-F2-B6) was estimated to have the lowest overall block fuel use. However, as will be seen in section 4.2 of this report, this engine diameter needed to be increased from 108.6in to 112.8in in order to achieve the same take-off field length as the baseline airplane and should be increased still further to achieve the best block fuel use.

The largest BPR engine (GE58-F2-B5) was designed with about the same FPR and diameter as the baseline GE90 engine. However, the BPR was significantly higher on the UEET engine (13.1 versus 7.8 for the GE90). This engine also needed to be resized to enable the airplane to meet the same performance as the baseline airplane. When matching a UEET powerplant to a current technology engine with the same fan diameter and FPR, the BPR was significantly higher for the UEET engines. This indicates that the engine core is operating more efficiently, using less power to drive the fan. This results in the engine core using less air that in turn boosts the BPR.

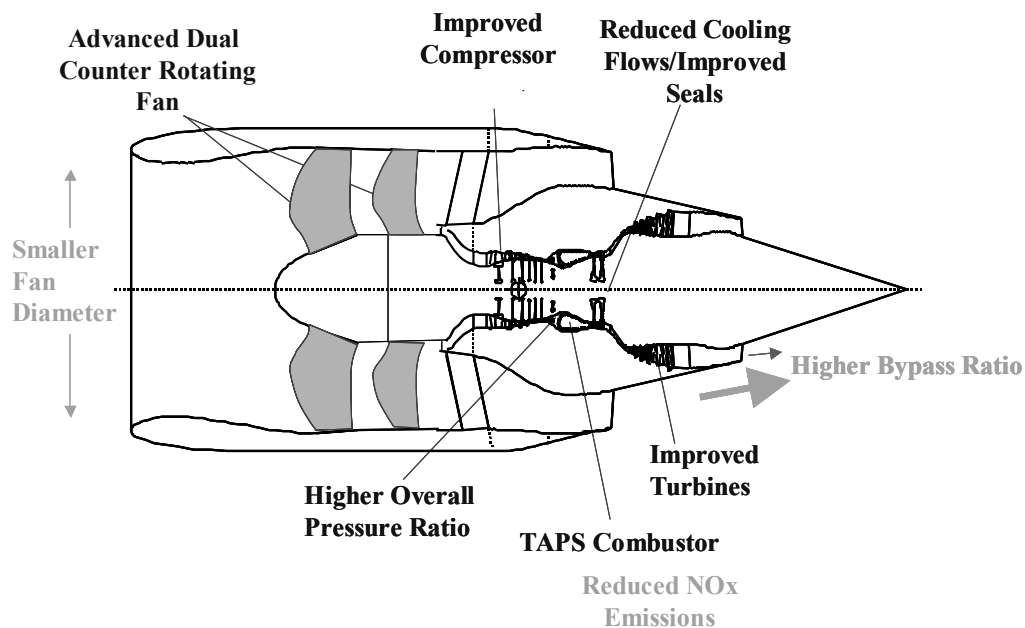

Figure 2.6. GE UEET powerplant design

Table 2.1. GE UEET design points

Engine Label	Baseline GE90-94B	GE58-F2 B7	GE58-F2 B6	GE58-F2 B5
Fan Dia (in)	123.0	100.6	108.6	123.5
BPR	7.8	7.43	9.47	13.1
FPR Design	1.46	1.8	1.65	1.45
Nacelle L/D	--	1.58	1.56	1.42

2.3.2 P&W UEET Powerplants

Pratt & Whitney provided both engine and nacelle data to the Boeing company. As will be described later, the nacelles were redesigned by BCA to achieve the lowest possible drag while using revised design weights.

Pratt & Whitney used increasing fan diameters to progressively lower the FPR. Lower fan pressure ratios typically improve the propulsive efficiency, thus reducing the load on the engine core while improving the BPR and cruise SFC.

The lowest BPR engine (STF 1171) was a conventional direct drive fan. This engine used a 6in larger diameter fan (118.5in dia.) than the baseline PW4090 engine (112.9in dia). This resulted in achieving a slightly lower FPR of 1.55 over the baseline engine's 1.6 FPR. However, the BPR increased significantly from 6.2 for the baseline PW4090 engine to 11.5 for the STF1171. The medium BPR engine (STF 1173) incorporated a speed reduction gearbox between the low pressure turbine and the fan. This feature further enabled increasing the BPR while maintaining an efficient turbine speed match. The fan diameter and FPR for this engine were similar to that of the GE90 baseline engine. However, again the BPR far exceeded that of the current technology engines (14.3 for the STF1173 vs. 7.8 for the GE90). The high BPR engine (STF 1174) was also a geared fan that included a variable area nozzle on the exit of the fan duct. This variable exit area enables a further improvement in propulsive efficiency by maintaining the fan operating line match between take-off and cruise. This is required with lower fan pressure ratio engines to prevent the fan from entering surge conditions. The STF 1174 data included an Advanced Technology Nacelle (ATN), as described in reference 8. This engine also used a unique core-mounted petal thrust reverser as shown in Figure 2.7. Design points for all engines are shown in Table 2.1.

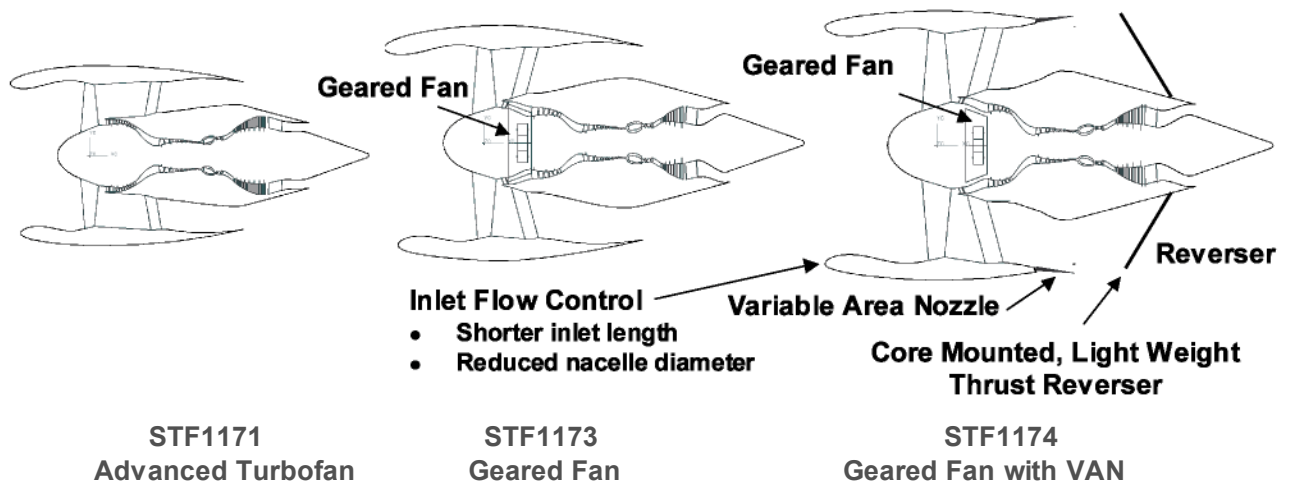

Figure 2.7. P&W UEET powerplant designs

Table 2.2. P&W UEET design points

Engine Label	Baseline PW4090	STF1171	STF1173	STF1174
Fan Dia (in)	112.9	118.5	127.9	148.7
BPR	6.2	11.5	14.3	21.5
FPR Design	1.6	1.55	1.45	1.32
Nacelle L/D	--	1.25	1.25	1.10

The ATN incorporated on the STF1174, utilized active flow control to enable a thinner inlet lip. Blowing flow in the boundary layer prevents flow separation during static and low speed operation. The thinner lip results in a smaller inlet highlight diameter which in turn results in a shorter and smaller diameter cowl.

The STF 1174 variable area nozzle (Figure 2.8) uses smart metal actuators. In the event of a failure, the actuators move to the full open position that allows the engine to operate surge-free during takeoff conditions, and also increases the windmilling airflow should the entire engine become inoperative. This higher inlet mass flow ratio enables a slimmer cowling without external flow separation for ETOPS range. The ATN, together with the core mounted petal reverser, enables a shorter fan duct as compared to the length normally needed for current translating cowl reversers.

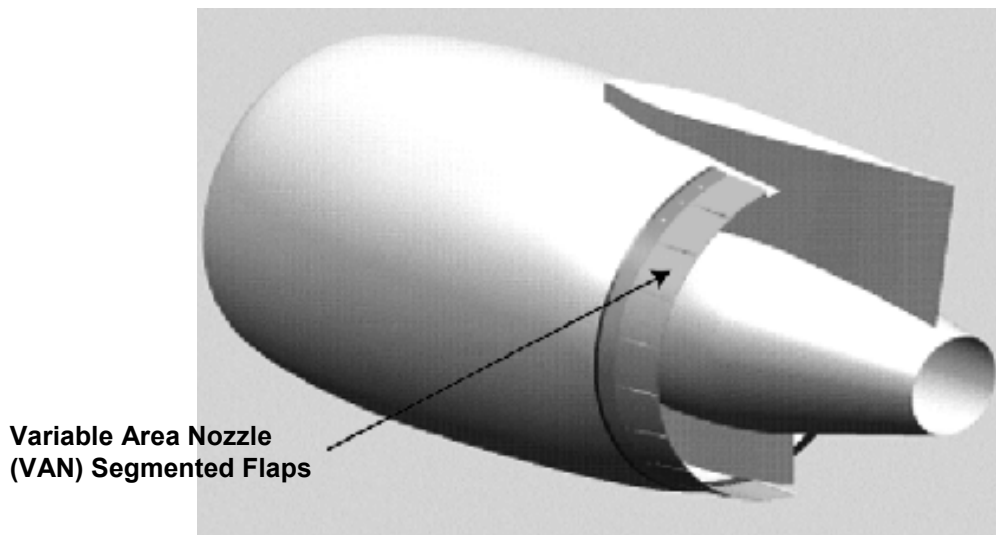

Figure 2.8. P&W STF1174 UEET powerplant with Variable Area Nozzle

The P&W provided nacelle design shapes were reviewed. Based on mass flow ratio characteristics using airflow data from P&W, the lines were modified for acceptable cruise and ETOPS drag characteristics. As will be discussed further in section 3.2, the length to diameter ratios were increased relative to the P&W lines. The weights were then estimated for the revised nacelle designs.

Figure 2.9 shows the relationship of FPR to BPR for the UEET engines and the two baseline current technology engines. The baseline current technology engines fall

on a line indicating relationship of FPR to BPR. For a given FPR, one can see that both GE and P&W UEET powerplants offer a higher BPR. At a FPR of 1.6, the GE UEET engine has almost double the BPR as the current technology engine. This is because of the higher engine pressure ratio, improved turbomachinery, and less cooling airflow required in the high technology engine core. The P&W engines show an even better BPR at any give FPR. This is because of the even higher BPR of these engines, and presumably also because of the effectiveness of the gearbox in optimizing the efficiency of the engine core.

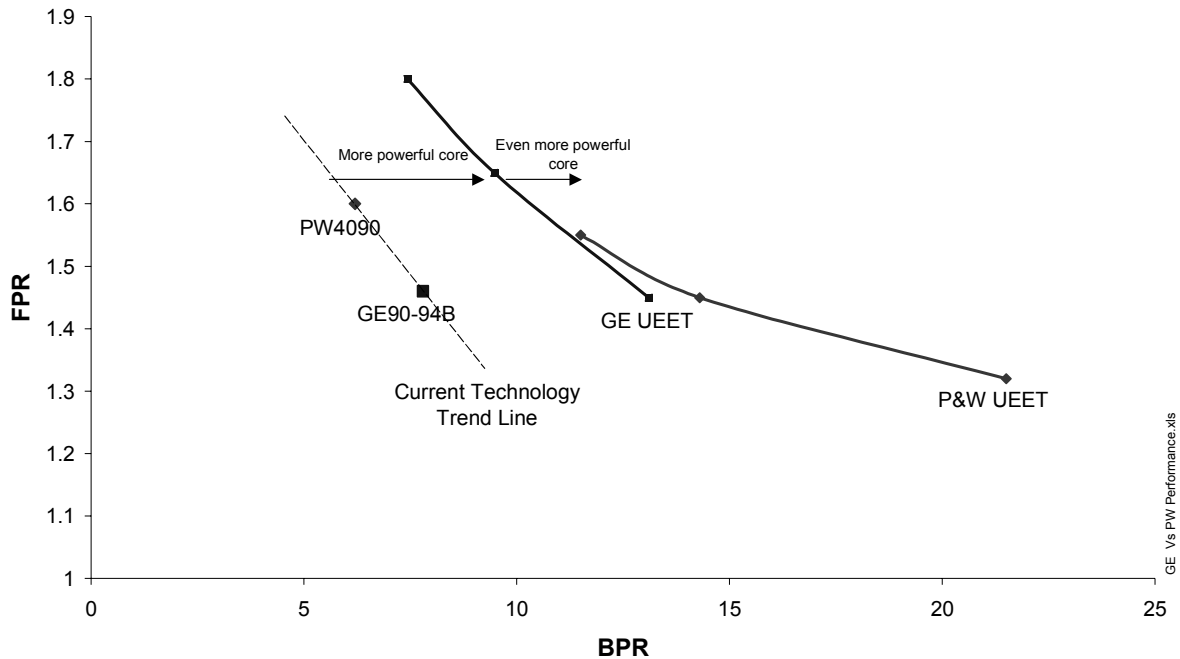

Figure 2.9. UEET powerplants FPR vs. BPR

Windmilling Drag – A form of drag to consider for engine-out conditions is the aerodynamic penalty associated with the inoperative engine—the drag generated by airflow having to windmill the engine’s fan and other rotating equipment.

Engines with large fan diameter engines incur larger windmilling penalties due to the increased fan frontal area and resulting large disturbance in airflow through the fan. During takeoff, the added drag for an inoperative engine is not a significant factor. However, the aircraft’s vertical stabilizer will need to be re-sized to maintain yaw control under minimum controllable conditions and is addressed in section 4.1. Table 2.3 shows the windmilling drag for the larger diameter P&W engines. The drag ranges from 1% of takeoff thrust for the small diameter engine (STF1171), to 2% for the largest diameter engine (STF1174).

Windmilling drag that is encountered while at cruise conditions during Extended-Range Twin-Engine Operations (ETOPS) is adversely impacted by larger diameter engines. Table 2.3 shows that drag more than doubles at 0.8 Mach for the largest diameter engine. An airline route structure analysis would be required to determine the penalty associated with this increased drag, considering the smaller volume of

fuel available in the aircraft wing tanks, and the requirement of safely reaching an alternate airport within 180 minutes of single engine failure. This analysis is outside the scope of this study but could result in the optimum bypass ratio being somewhat lower than determined herein.

Table 2.3. P&W windmilling drag

P&W Engine Type	STF1171	STF1173	STF1174
Fan dia (in)	118.5	127.9	148.7
Mach Number	Corrected Windmilling Drag	Corrected Windmilling Drag (%)	Corrected Windmilling Drag (%)
0.20	Base	126%	200%
0.80	Base	126%	188%

3.0 DESIGN ANALYSIS

3.1 Performance

Engine SFC - The relative uninstalled engine SFC versus fan diameter is shown in Figures 3.1 and 3.2. This shows the general trend that, when considering the engine alone, as the engine fan diameter increases (fan pressure ratio decreases) specific fuel consumption decreases.

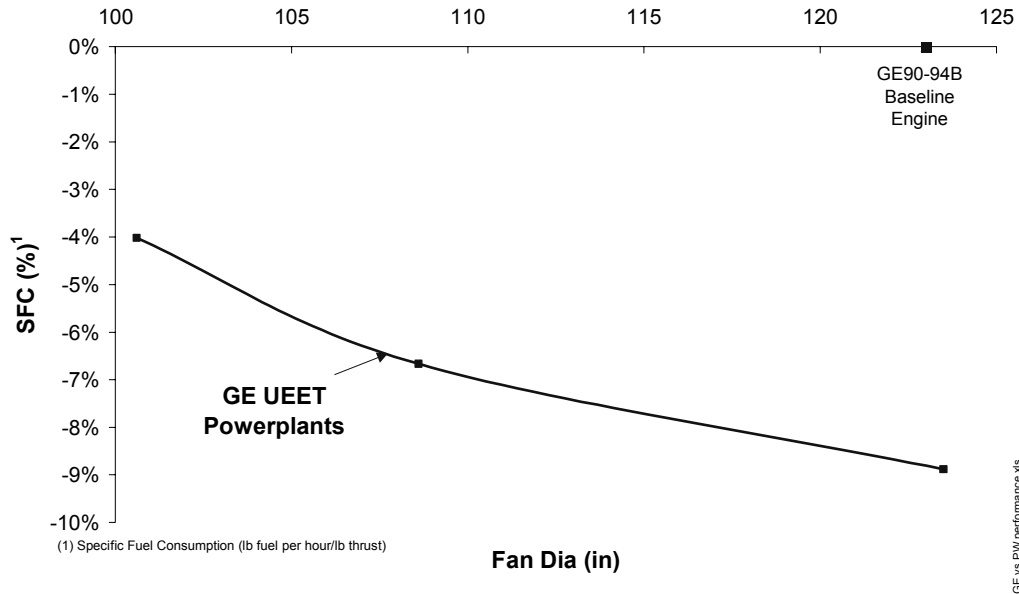

Figure 3.1. GE UEET powerplant SFC vs. fan diameter

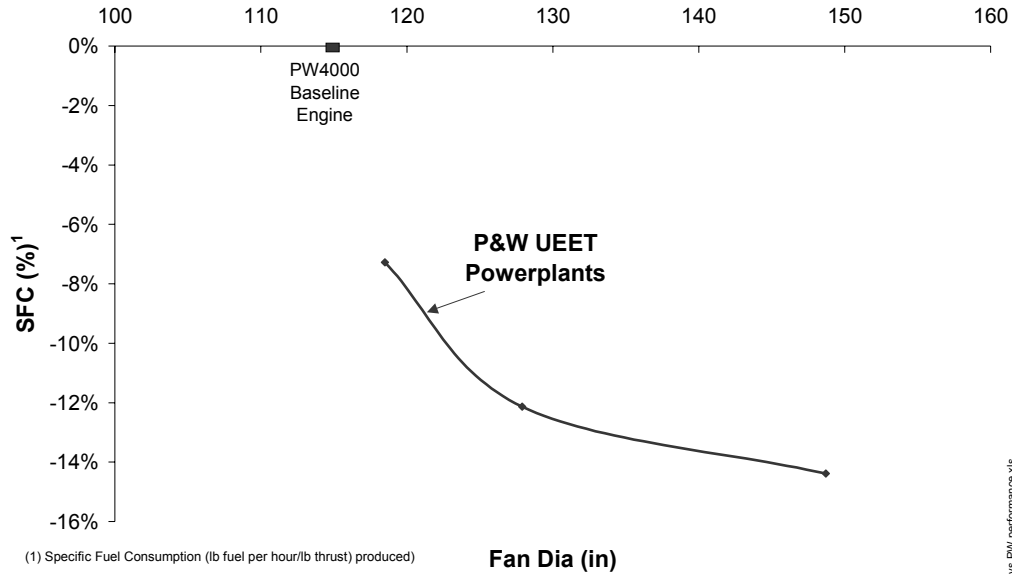

Figure 3.2 P&W UEET powerplant SFC vs. fan diameter

While the uninstalled engine SFC is reduced with increasing fan diameter, the required larger fan and nacelle also results in increasing engine and nacelle weights along with increasing nacelle drag.

Thrust – As engine fan diameter increases, sea level static thrust also tends to increase. However, as the speed of the aircraft and engine increases, engine thrust tends to drop off. The larger the fan diameter the lower the FPR resulting in a larger drop off in thrust with increased speed. Figure 3.3 shows this relationship for the P&W engines, such that at 0.25 Mach, all of the engines have the same thrust.

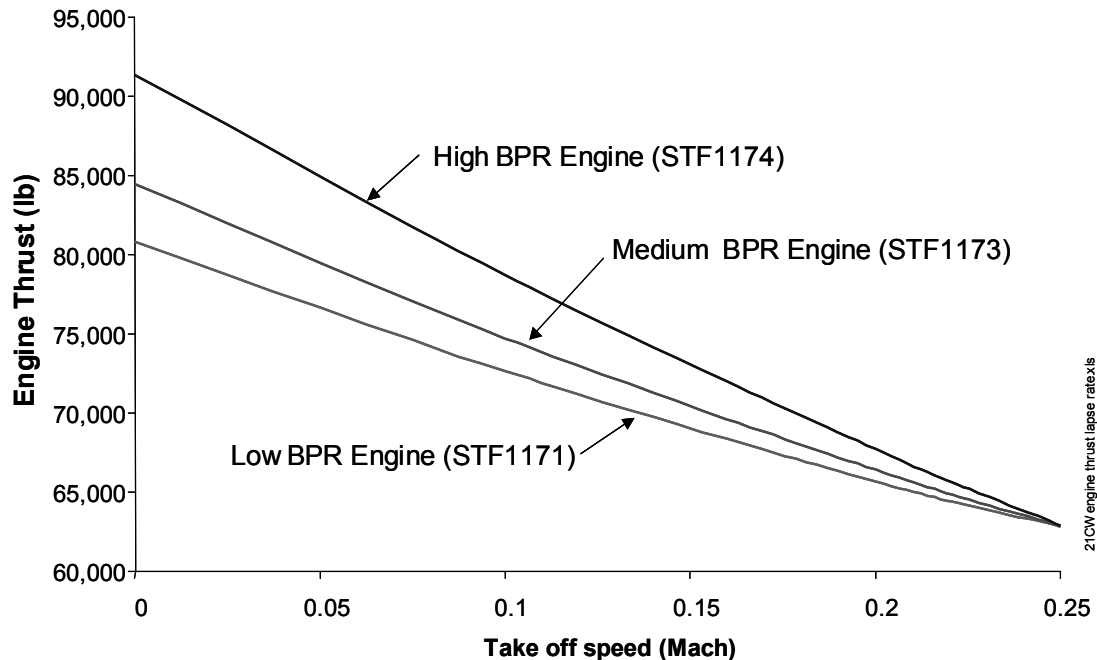

Figure 3.3. UEET thrust lapse with speed

The GE engines also exhibit this fall off in thrust with increases in speed. Although all of the delivered UEET engines had about the same thrust level at 0.25 Mach, Figure 3.4 shows a direct relationship of static sea level thrust to engine fan diameter.

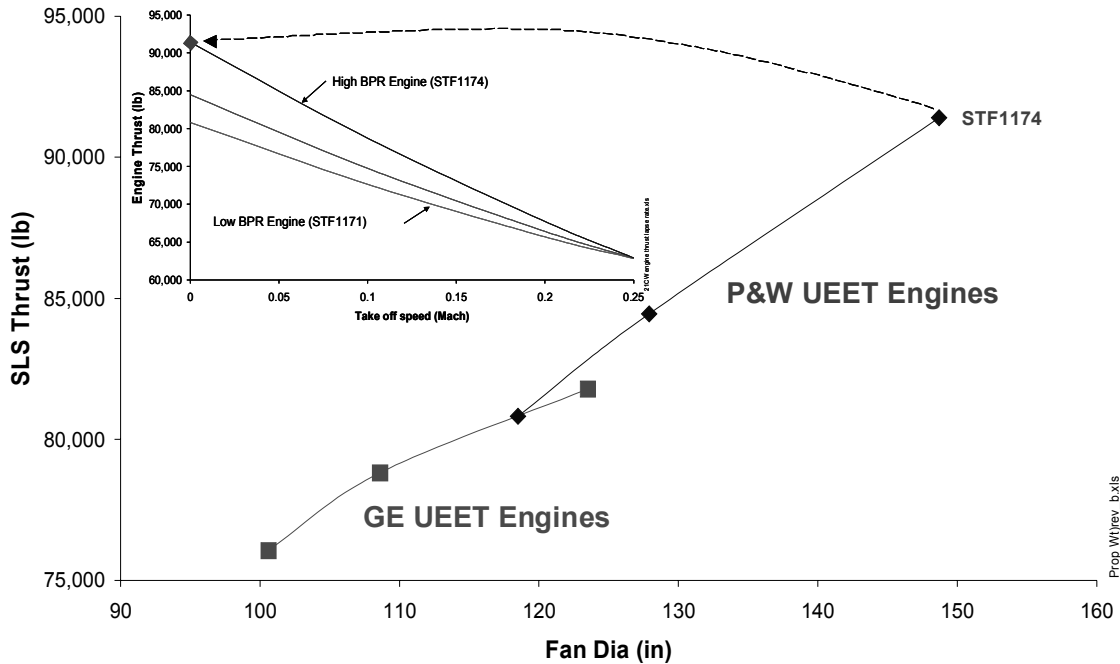

Figure 3.4. SLS thrust for engines with same thrust at 0.25 Mach

Since all of the base UEET engines have about the same thrust at 0.25 Mach (takeoff conditions), but each engine has different drag, engine-out characteristics, SFC, and weight variables, the resulting differences in airplane TOGW required that each of the engines needed to be resized to achieve equivalent takeoff performance. In addition, the engines needed to be sized so that the aircraft were able to at least reach the minimal required initial cruise altitude conditions. Section 4.0 will discuss the resizing exercise.

3.2 Drag

Engine Installation Drag Assessment

Thrust/Drag Accounting: In an engine installation, although the power plant does provide thrust, it also is a source of drag. In order to accurately account for all of the forces a consistent and agreed upon bookkeeping system needs to be employed. This is to ensure that all forces are properly accounted for and that no double bookkeeping occurs. Typically the captured stream tube and the exhaust plumes are booked as thrusting forces and the external lines which are washed by freestream airflow are accounted in the drag forces. These surfaces include the external nacelle lines, the strut and any additional shapes which may be added to both such as chines, fairings, accessory bumps, etc.

Aerodynamic Installation Considerations: In order to achieve a minimum drag solution, a well coordinated effort between all parties needs to be conducted. A number of design variables and constraints need to be considered for an efficient installation. These include things such as minimizing wetted area by wrapping the engine, support structure and systems with the minimum shape necessary. Positioning the engine in the proper orientation relative to the localized flow conditions as well as fore and aft is also essential to minimize interference effects on the wing. For the purpose of this study, all of the engines evaluated were positioned using our best design practices for modern twins and include the following design assumptions. Each wing would be design optimized for the unique engine diameter under study. The fan nozzle is located in front of the wing leading edge, and the nacelle is of a separate flow design. Also the gully height, the minimum gap distance between the lower surface of the wing and the nacelle, is held at a consistent parameter for all nacelles.

When evaluating different design trades, a breakdown of the engine installation drag has been made. For the purpose of an initial evaluation of propulsion installation, the following types of drag are assessed. Even though these aren't all of the sources of drag, they represent the primary drivers and the ones that are the most sensitive to design variables that can be controlled. They include profile and wave drag on the nacelle and strut, interference effects of the propulsion package on the wing, and excrescence drag from the various panel gaps, accessory fairings, fasteners, etc.

Nacelle Profile Drag

In the propulsion installation, the nacelle is the largest aerodynamic surface with the greatest wetted area. As such, its profile drag is the greatest contributor to the total drag. Therefore careful attention to its design is essential for minimizing drag. However, because of the many requirements that define its shape, sometimes very little is left for the designer to change.

The two largest design drivers are overall length and maximum diameter. Maximum diameter is often set by the engine size, its surrounding systems and their clearance requirements, thereby leaving length as a possible design parameter to vary. However, the ratio between the two is also important because stubby nacelles, those that have a low length over maximum diameter, (L/D_{max}) have a tendency to exhibit high wave drag. Wave drag is the drag associated with shock waves that form on the nacelle surface. This is due to the high curvatures associated with stubby nacelles, and the rapid acceleration and de-acceleration that the flow undergoes. However, if a nacelle is too long, then a penalty for extra wetted area is incurred with this additional area being of no benefit to the installation. Therefore, the goal is to design a nacelle with a favorable L/D_{max} ratio to eliminate wave drag, while still satisfying all of the other design requirements and constraints.

The analysis method used for assessing the profile of the nacelles is based upon ESDU 81024, *Drag of axisymmetric cowls at zero incidence for subsonic Mach numbers.*⁽¹⁰⁾ The BCA methodology includes correlations to published and unpublished experimental data. Profile drag for the two UEET engine manufacturers were quite different due to the different engine architectures.

Both engine companies provided basic bare engine dimensions. Nacelle lines using current BCA design practices were drawn up for the GE engines choosing an appropriate L/D_{max} ratio to eliminate wave drag. Pratt and Whitney also included nacelle lines as well as bare engine info. The P&W engines were assessed with the original as drawn lines, but had very high wave drag associated with them because of their low L/D_{max} ratios. BCA re-designed the lines to eliminate wave drag and those nacelles were used for the rest of the study. A discussion of that effort follows.

Figure 3.5 illustrates the “original” and “revised” cowl design concept for the largest diameter P&W STF1174 engine along with the total nacelle drag. At the original L/D_{max} ratio of 0.92 the total nacelle drag (wave + profile) was higher than the drag for the revised L/D_{max} ratio of 1.1. This kind of analysis was performed for each of the nacelles and new lines with no wave drag were established.

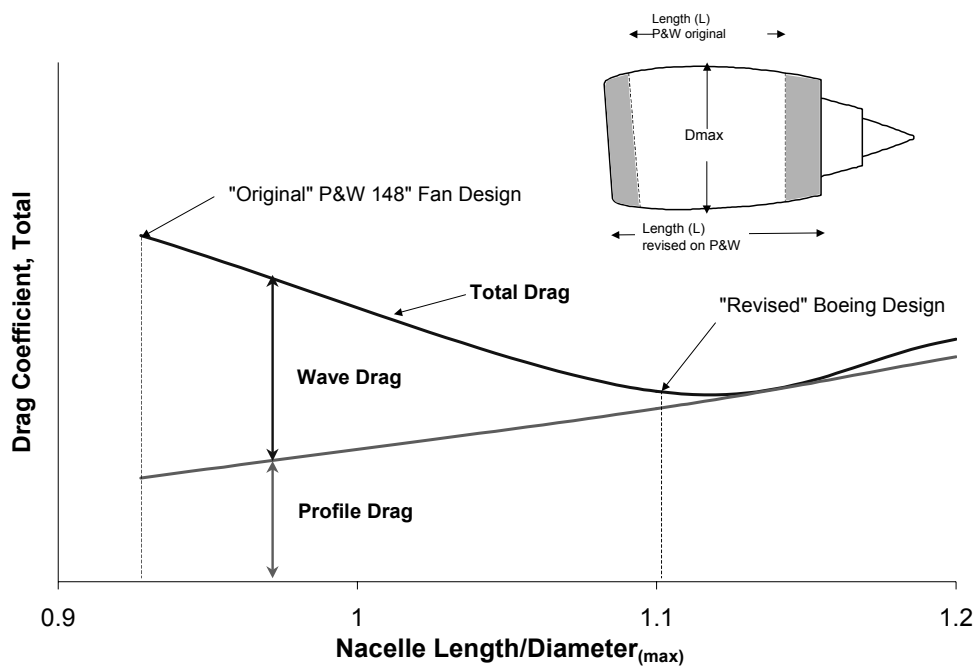

Figure 3.5. Large diameter P&W nacelle redesign and drag coefficients

The revised ratios in comparison to the original lines are shown below in figure 3.6. As can be seen, different engine philosophies resulted in different L/D_{max} ratios. The smallest diameter P&W engine nacelle needed only a slight lengthening. The mid and large diameter engines both required significant lengthening to reduce the total drag. The GE UEET engines actually have higher L/D_{max} values than the baseline GE90 engines. This is because the GE UEET engines have dual counter-rotating fans that need to be housed by a longer cowl. By using advanced nacelle technology, the P&W UEET engines are housed within a proportionally shorter length nacelle than the baseline PW engines.

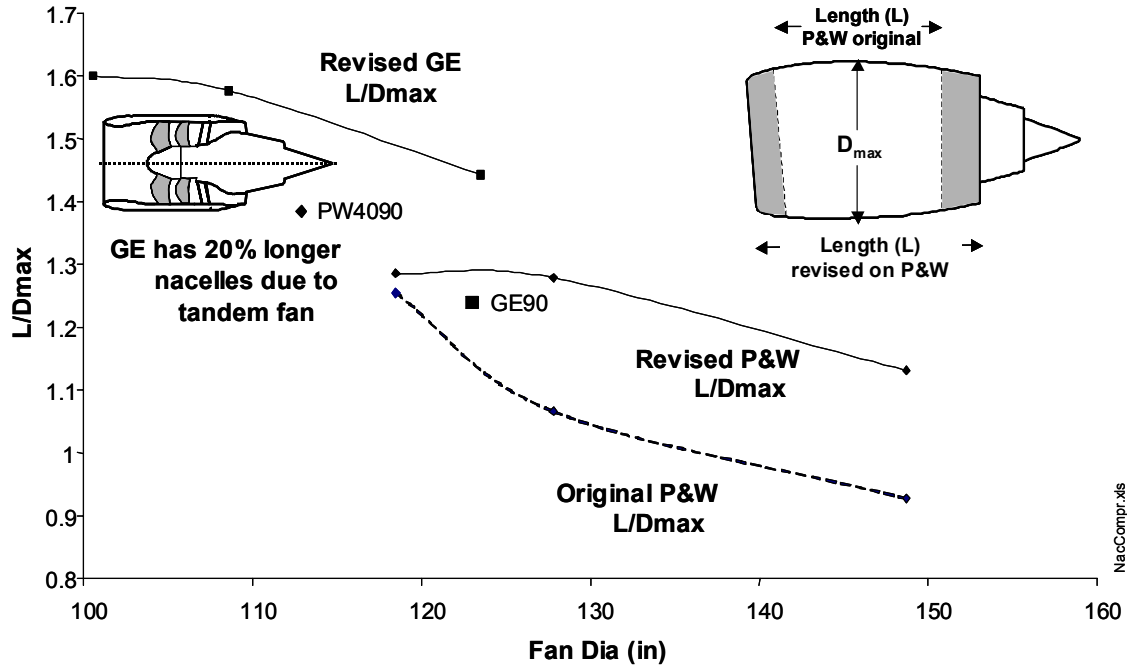

Figure 3.6. Nacelle L/D_{max} values

Figures 3.7 and 3.8 show the profile drag for both of the revised nacelles on the GE and P&W engines.

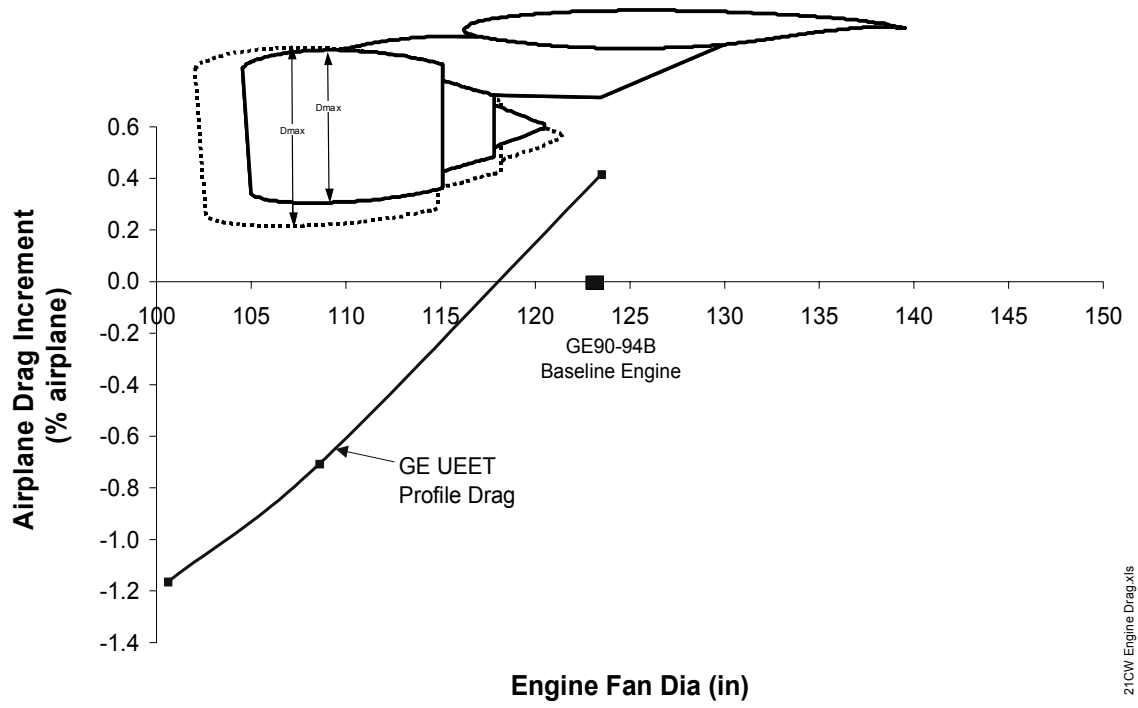

Figure 3.7. GE UEET profile drag

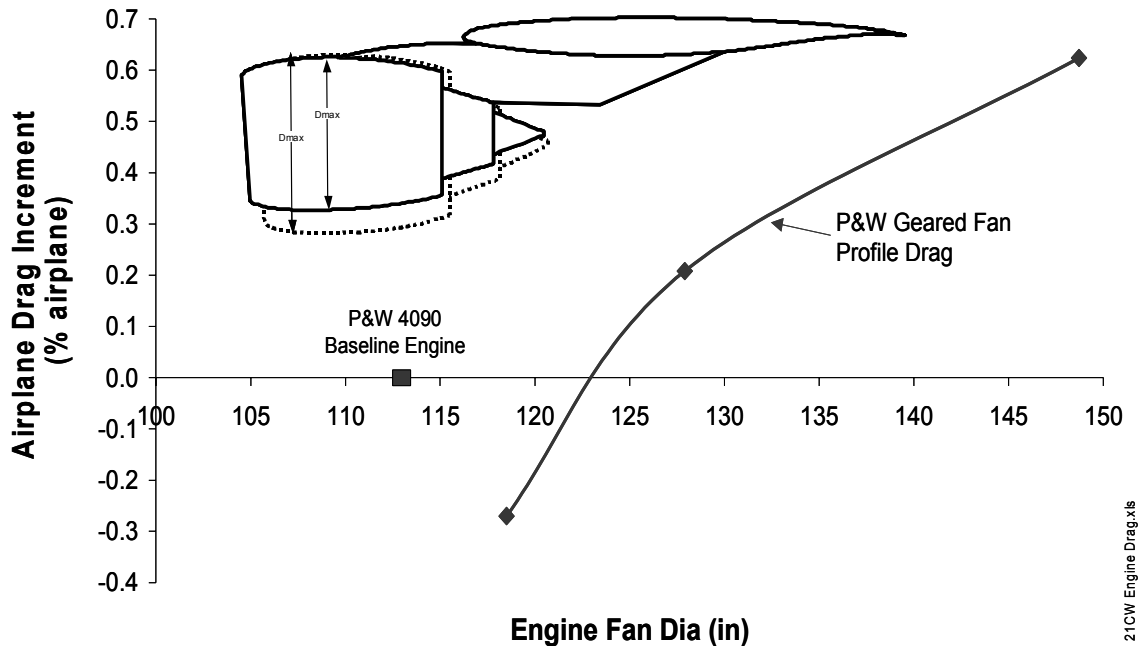

Figure 3.8. P&W UEET profile drag

In summary, the GE UEET engine nacelles were slightly higher in drag than nacelles for current technology engines largely due to increased length. However, the engine diameter is smaller which makes for easier integration onto the airplane. On the other hand, the P&W UEET engines incorporate advanced nacelle technology to minimize wetted area, and thereby reduce drag. However, these engines are significantly larger in maximum diameter than current technology engines.

Strut

Handbook methods, based upon experimental and analytical data along with CFD results were used to assess the drag on the strut. Strut profile drag is largely a function of the total wetted area of the strut. Occasionally, a strut may also exhibit wave drag. For the purpose of this study, adequate clearance between the lower wing surface and the nacelle was realized and it was assumed that the nacelle and strut could be properly integrated using best design practices and not incur a wave drag penalty.

Interference Drag

In an ideal world, the total drag would be equal to the sum of the individual components. However this is often not realized even with the very best of design methods and design. This difference in drag is quantified as interference drag and estimates are based upon years of wind tunnel experience, CFD analysis and flight test. Interference drag is largely characterized by the affect that the nacelle and strut have in changing the flow around the wing as well as the various interactions between the individual parts, such as the interface between the strut and nacelle and the strut and wing. It also includes the powered effects of the jet exhaust below the wing. Handbook methods developed for initial study use were used in

performing this analysis. It should be noted that these nacelles are quite large in comparison to previous nacelles, therefore they may present a rather large challenge in developing a minimum interference drag installation for engines of this size. The results are fairly consistent for all UEET engines and are summarized below in Figure 3.9.

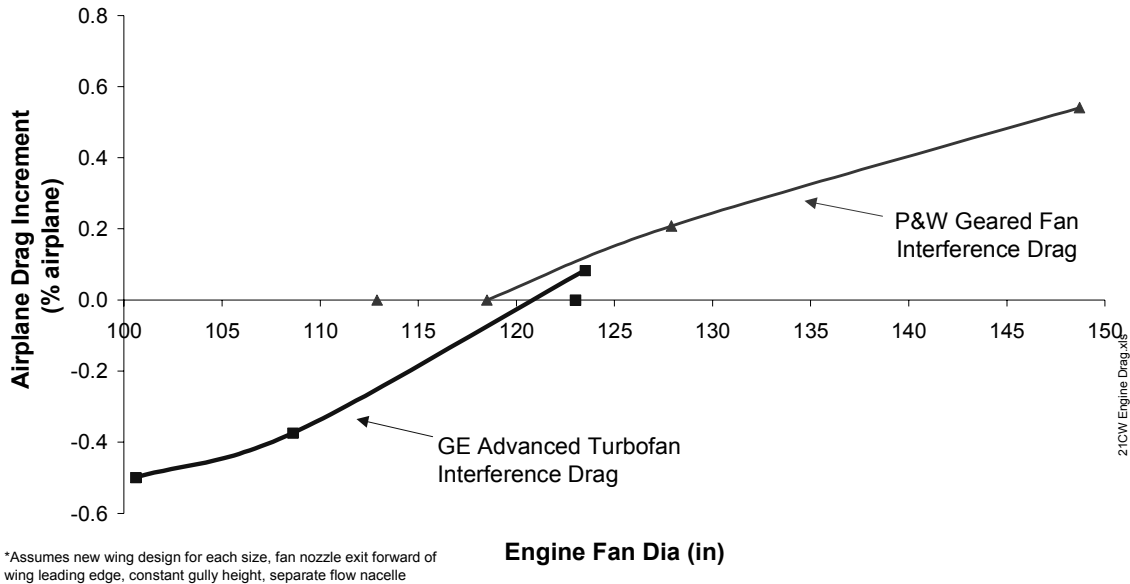

Figure 3.9. Interference drag for UEET powerplants

Excrescence Drag

Excrescence drag is the drag due to the realities of manufacturing a physical nacelle in comparison to the idealized loft lines. In other words, the nacelle and strut are made from numerous parts with panel gaps, exposed fasteners, different finishes, vents, fairings, etc. An allowance based upon anticipated best practices was made to each of the engine installations.

Other Drag Sources

Chines and fairings are other design details which may contribute to the profile drag of the propulsion package installation. However, the exact details of those elements are often not known in a study of this scope. For this study it was assumed that: (1) all engine installations included chines, (2) the chines were the same size for each engine, and (3) an optimal low drag installation could be achieved. The drag value was determined from experimental databases and analytical results.

Drag Results and Conclusions

The different engine architectures were the primary drivers in the differences in total propulsion installation drag. As shown in Figure 3.10, profile drag is the largest contributor to the total drag for the airplane, due to the large wetted areas of the nacelles. Interference drag is the second largest source and increases with

maximum diameter. The challenge with integrating high BPR engines on the airplane will be to find a good balance between total drag and fan diameter.

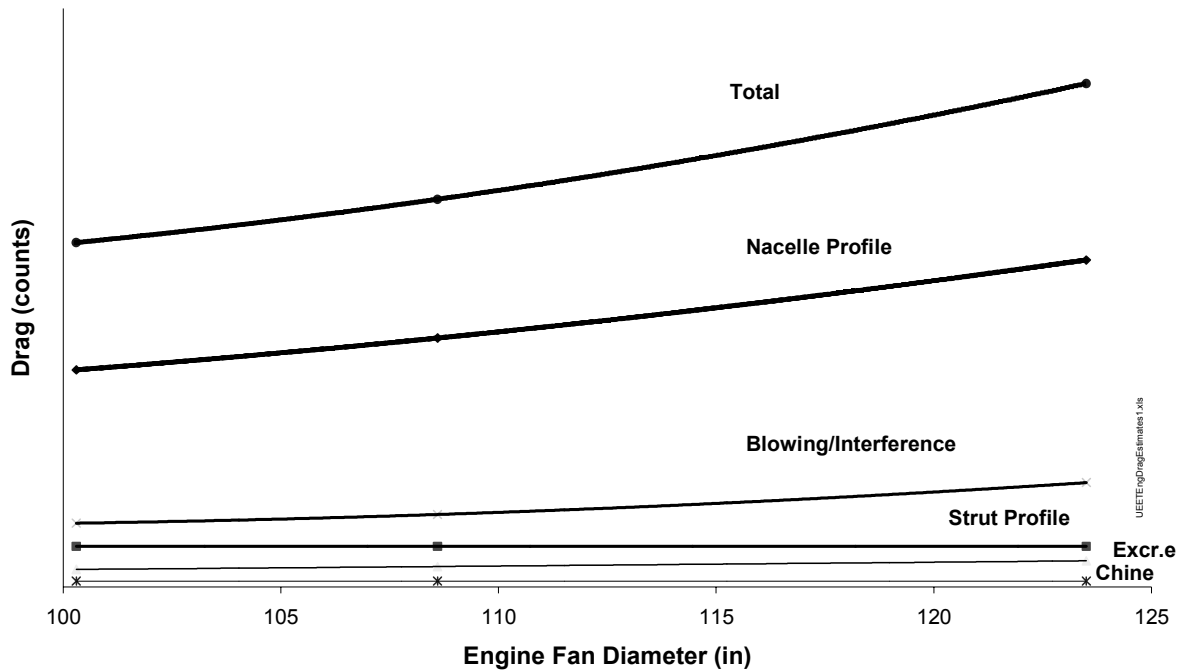

Figure 3.10. Total Propulsion Installation Drag Buildup

3.3 Weight

3.3.1 Engine weights assessments

High-level engine and nacelle weight data were supplied by both GE and P&W. An analysis of the specific weight data was performed to validate the information. A weight comparison, showing current technology and UEET engines, is presented in Figure 3.11. This chart shows the UEET engines are significantly lower weight than current technology engines. It also indicates that the P&W engines are lighter weight than the GE engines when comparing only fan diameter to engine weight. This is due to the gearbox that is used on the P&W engines. These engines were able to achieve larger fan diameters for the same takeoff thrust than would otherwise be possible.

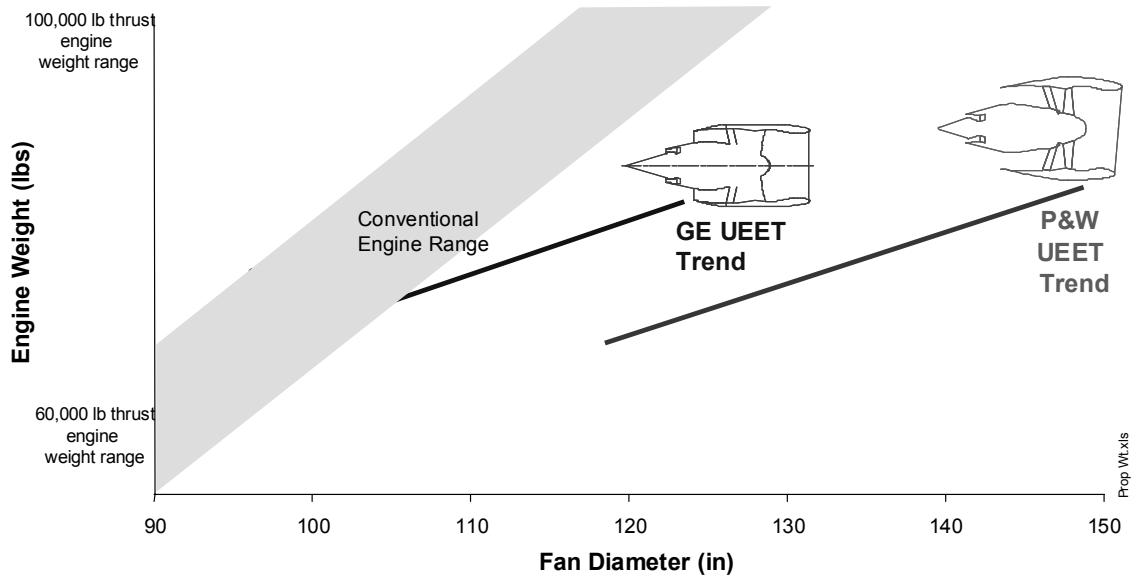

Figure 3.11. UEET engine weight vs fan diameter

However, when taking into account that these large fan diameter engines experience large thrust lapse rates, one needs to also evaluate engine weight versus Boeing equivalent thrust (SL thrust at 0.25 Mach X 1.2553) as shown in Figure 3.12

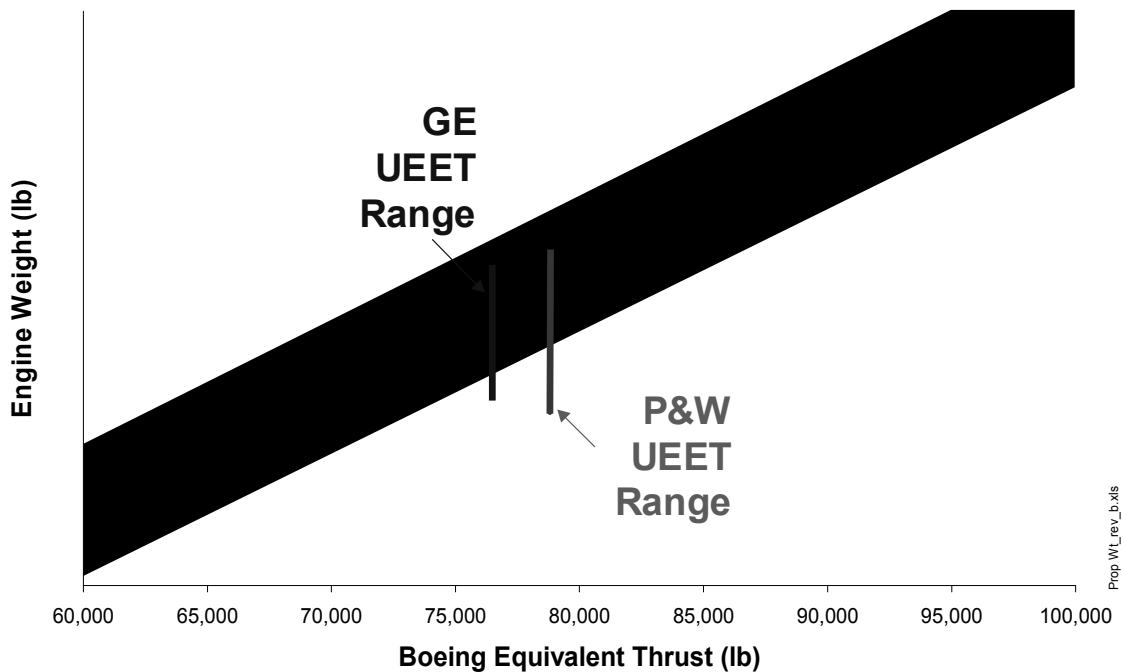

Figure 3.12. Engine weight vs. Boeing Equivalent Thrust

When taking into account the thrust lapse of these high BPR engines, it becomes apparent that the engines fall within normal weight ranges of today's engines.

Achieving lower weight in UEET engines is a significant factor in enabling these high by-pass ratio engines that reduce fuel use.

3.3.2 Nacelle weights assessments

Nacelle weight information was supplied by both GE and P&W. However, when the nacelles were re-sized, the weight of the nacelles was changed to reflect the increased length of the P&W nacelles. The following assumptions went into the nacelle weight analysis:

- 1) 777 PW4098 nacelle materials types and detail design approaches
- 2) Inlet weights include thermal anti ice hardware
- 3) Acoustic lining in the inlets and cascade T/Rs maximized for noise attenuation
- 4) Insulation is required on the inner wall of the cascade T/Rs
- 5) Engine mounts, exhaust nozzles, and exhaust plugs are titanium
- 6) Precooler weight not included in engine build unit
- 7) No margins or growth allowances are added or included

A United Technologies report⁽¹²⁾ describes the variable area fan nozzle and petal type core mounted fan reverser design concepts used on the STF1174 engine. Several questions surfaced about the fan reverser design relative to space requirements, actuation approach, effectiveness and materials types consistent with hot core temperatures which could not be addressed within the time allowed to develop the weight estimate.

The UEET nacelle weights are shown in Figure 3.13 for the resized thrust engines. The P&W nacelles are for isolated nacelle data provided by P&W that were revised to achieve minimum drag and Mach 0.85 ETOPS capability. The lower weight for the large diameter P&W engine (STF1174), as compared to the other UEET engines, is shown in the comparison and is due to the technology basis change, taking advantage of the much larger diameter reduced thrust reverser requirement and changing to a petal type reverser. The very high BPR results in increased ram drag. The increased retarding force from the increased ram drag allows for a decrease in thrust reverser effectiveness. The relative stopping capability on slippery runways with the lower reverser effectiveness from the petal reverser was not estimated. The integration considerations need to be evaluated but were out of the scope of this study.

Boeing does concur with P&W that the fan reverser concept appears lighter than a cascade type reverser at the 150in fan diameter size range. The inlet may grow very heavy because of its size. A better understanding of acoustic requirements for this engine installation might result in a lighter approach. The STF1174 nacelle design is a key area for future technology development.

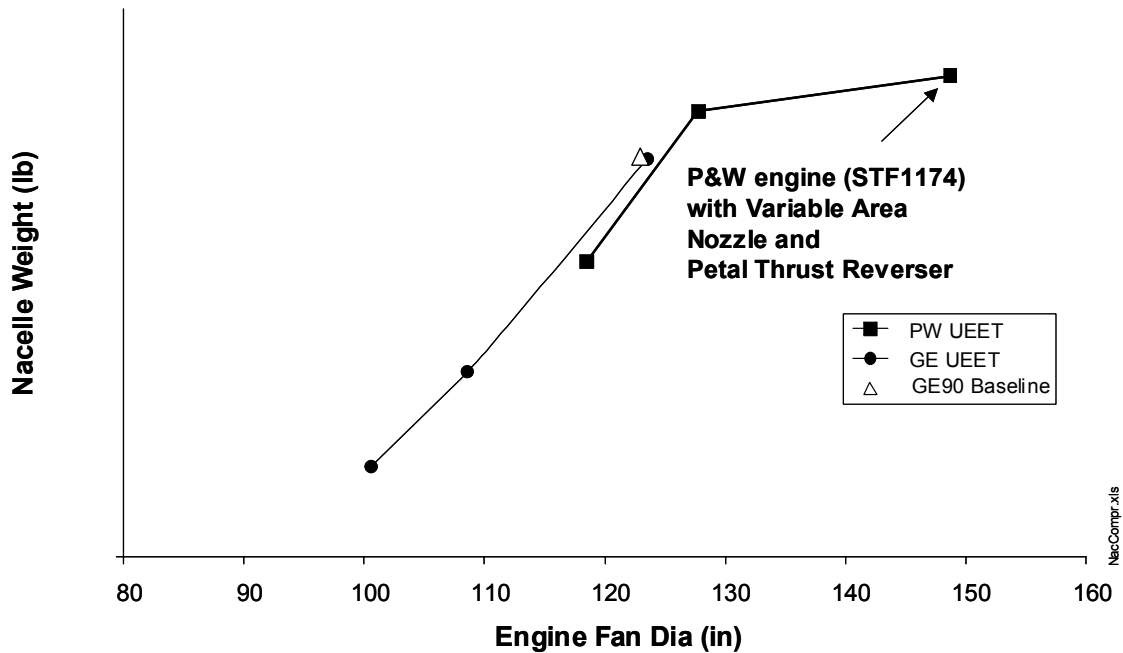

Figure 3.13. P&W and GE UJET nacelle weight comparison

3.4 Integration

Proper integration of the engine into the airframe plays an important role in determining the ultimate fuel efficiency of the airplane. Replacing an existing engine on an aircraft with a more fuel efficient engine will only result in achieving partial fuel efficiency gains. In order to achieve the maximum benefits, the airframe must be designed for the specific engine. Figure 3.14, shows the incremental aircraft fuel efficiency gains made possible by replacing only the engine, by adding airframe technology, and finally by designing the airframe to fit the efficient engine.⁽²⁾ For example, when using a more fuel-efficient UJET engine, the wing need not be designed to carry as much fuel and so the weight of the wing can be reduced to further reduce fuel use.

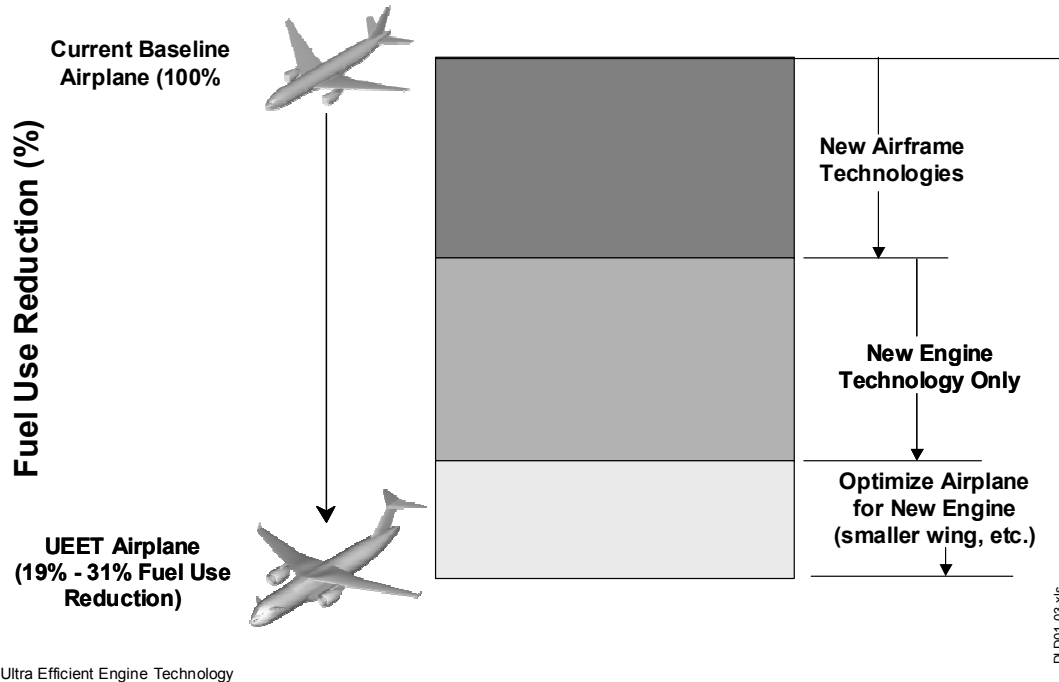

Figure 3.14. Airplane integration fuel efficiency effects⁽²⁾

In order to determine the optimum aircraft configuration and mission performance, a Graphical Computer Aided Sizing and Optimization System (GCASES), developed by the McDonnell Douglas company, was utilized in the study. GCASES is an interactive program that combines inter-disciplinary modules to rapidly iterate to a configuration that satisfies all of the specified performance requirements. GCASES was calibrated by the Phantom Works Huntington Beach (PWHB) team to match the baseline BCA sized configuration..

An aircraft can be designed to optimize one of several performance factors (weight, speed, altitude, climb, fuel efficiency, cost, etc.). For this study the baseline aircraft was modified, by integrating advanced UEET engines of varying BPR and diameter, to minimize the resulting economic costs which closely follows fuel efficiency. The GE and P&W UEET engine designs bounded the region that was expected to provide the optimum BPR for each technology.

The sizing drivers listed below in Table 3.1 were used for the six study UEET engines that were installed on the baseline study airplane.

Table 3.1. Engine integration issues

1. Engine specific performance (SFC, FPR)
2. Engine weight
3. Nacelle drag
 - a. Profile
 - b. Wave
 - c. Blowing
 - d. Interference
 - e. Excessance
4. Ground clearance with gear length and wing shear
5. Engine out performance (windmill drag, 2nd segment thrust, and ETOPs requirements)
6. Airplane thrust requirements (top of climb and takeoff field length)
7. Thrust reverser operation (effectiveness, plum impact, and door clearances.
8. Engine placement (strut and flap designs)

3.5 Operating Cost

The Economic value of a configuration is measured by BCA in Cash Airplane Related Operating Costs (CAROC). Figure 3.15 shows the components making up the CAROC for the study aircraft. They are Trip Fuel Costs (also referred to as fuel burn), Cabin Crew, Flight Crew, Maintenance, Landing Fees, Ground handling, Communications, Ground Power and overhead. A majority of the CAROC is contained in the first 6 components. Operating Empty Weight (OEW) of the aircraft is also a consideration in that it plays into the assumed maintenance costs of the aircraft—the heavier the aircraft, the higher the maintenance costs will be.

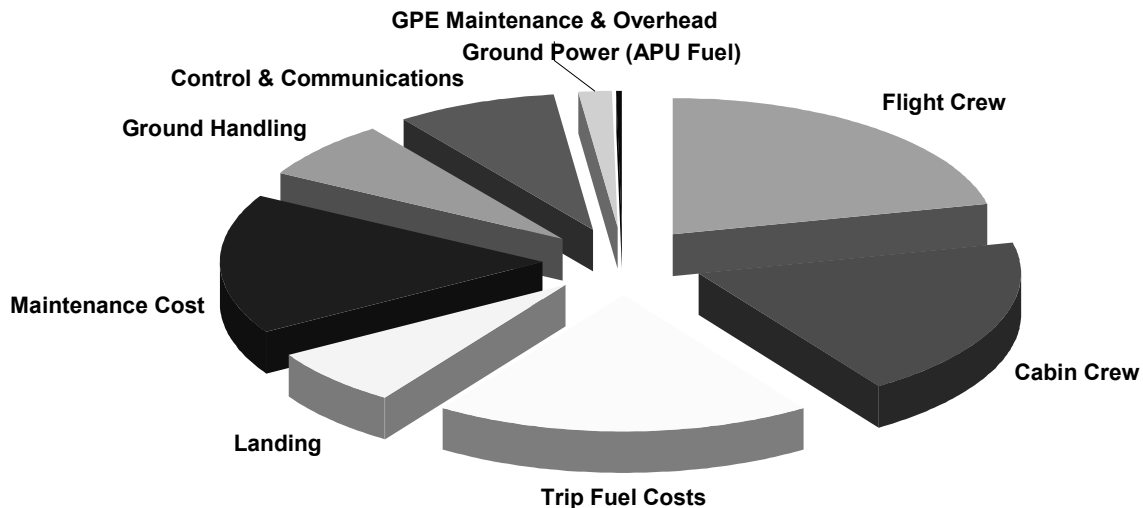

Figure 3.15. Baseline Cash Airplane Related Operating Cost

In this study we hold block time, with its engine maintenance cost component, constant. Engine maintenance will vary between the geared fan technology and dual counter-rotating fan technology. But for optimization, maintenance variation for a technology should be insensitive to BPR with small thrust variations. The driving variables for optimization for minimum CAROC then are block fuel and TOGW.

To identify the optimum trend, an approximate iterative point design method is used to indicate the engine and airframe sizing that would provide the minimum for that function. Minimum block fuel versus minimum TOGW is then biased using the sensitivity of delta % CAROC per delta % function times the function sensitivity to engine diameter variation. For example, for each 1% fuel burn increase, trip cost increases 0.23%. For each 1% TOGW increase, assuming OEW impacts, trip cost increases 0.17%. So for a minimum cost solution, an optimum fuel burn % to TOGW% ratio is 1.4:1. For the diameter sensitivity, from Figure 3.20 it is shown that block fuel is about 9 times more sensitive to change of BPR than TOGW. This gives a net weighting (CAROC/BPR = CAROC/Function * Function/BPR) of $9 \times 1.4 = 12:1$. Hence for this study, the optimum BPR can be achieved simply by minimizing block fuel.

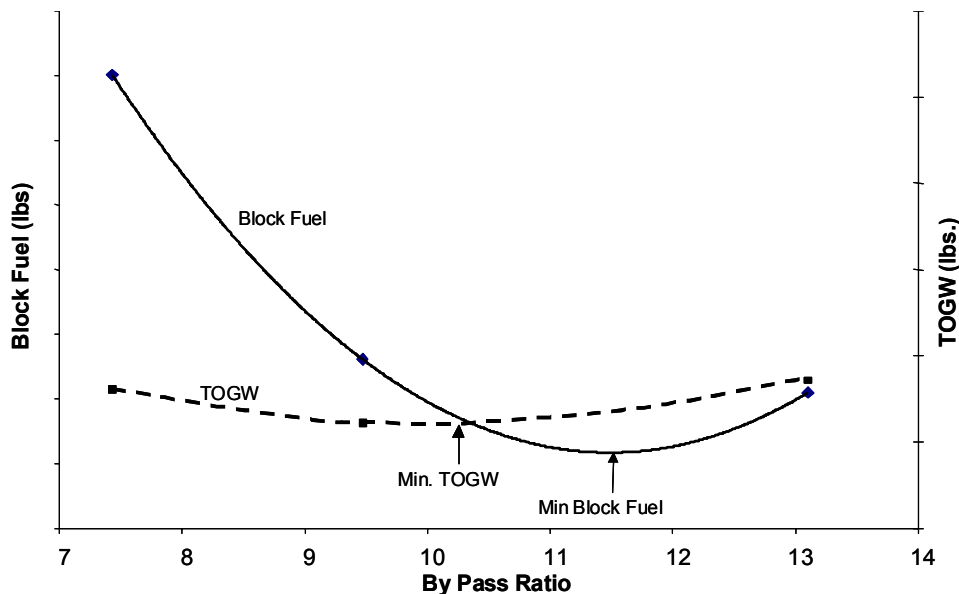

Figure 3.16. GE UEET powered airplane block fuel vs TOGW

3.6 Noise

Aircraft noise was estimated for the GE and P&W UEET engines based on BCA calculation methodologies. Except for the two highest BPR GE UEET engines, minimal engine performance information (e.g., exit velocity profiles and rotor speeds), was available. Therefore the analysis was conducted parametrically using fan pressure ratios, aircraft take-off weights, take-off thrust levels, and estimated aircraft climb performance information.

For the reference 777-200ER type airframe and engine and the two highest BPR GE UEET engines (BPR of 13 and 9.5), each engine noise source was modeled based on individual engine component geometry and engine cycle parameters at the sideline, cutback and approach performance conditions. The resulting predictions for the reference airplane were then compared to interpolated approved FAA certification levels and the small differences then applied to all the predictions based on detailed component analysis. Measured certification airframe noise for the 777-200ER was also scaled to each airplane’s performance conditions as part of the detailed component analysis. The noise trends and results of this analysis are now discussed in the following paragraphs and figures.

On conventional aircraft engines, the air velocity at the fan exit nozzle is normally directly related to FPR—higher pressure ratios result in higher fan exit velocities. These higher jet velocities result in higher noise levels for the jet component due to increased jet wake shear that follows a velocity to the eighth power relation. All of the UEET engines have about the same FPR relationship to fan diameter as shown in Figure 3.17.

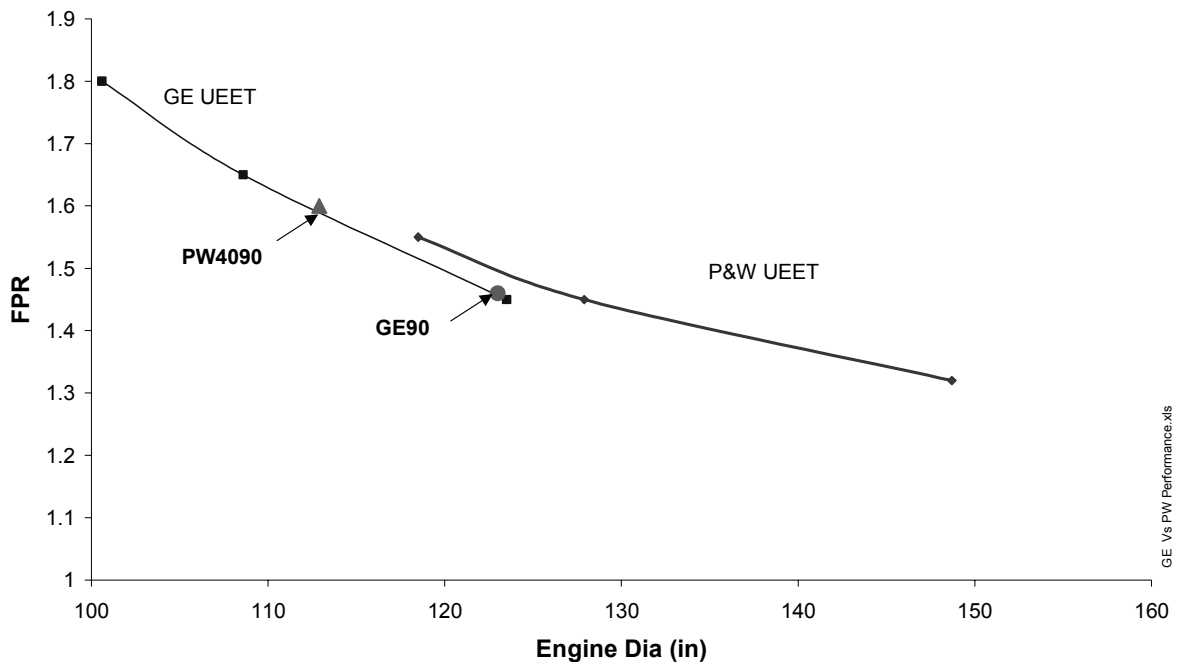

Figure 3.17. FPR vs. engine diameter

Since FPR is related to the jet noise component, a correlation between certification noise level and engine FPR is seen in Figure 3.18. It is also seen that the noise from the P&W UEET engines is about the same as the conventional engines at similar FPR as these engines have a conventional fan design. However, the GE UEET engines are shown to operate at a higher FPR for the same total noise level. This results from the fact that for a given total FPR each individual counter-rotating fan stage is operating at a lower FPR, and hence a lower fan blade tip speed, resulting in a smaller fan noise component which contributes significantly to the cutback and approach certification points.

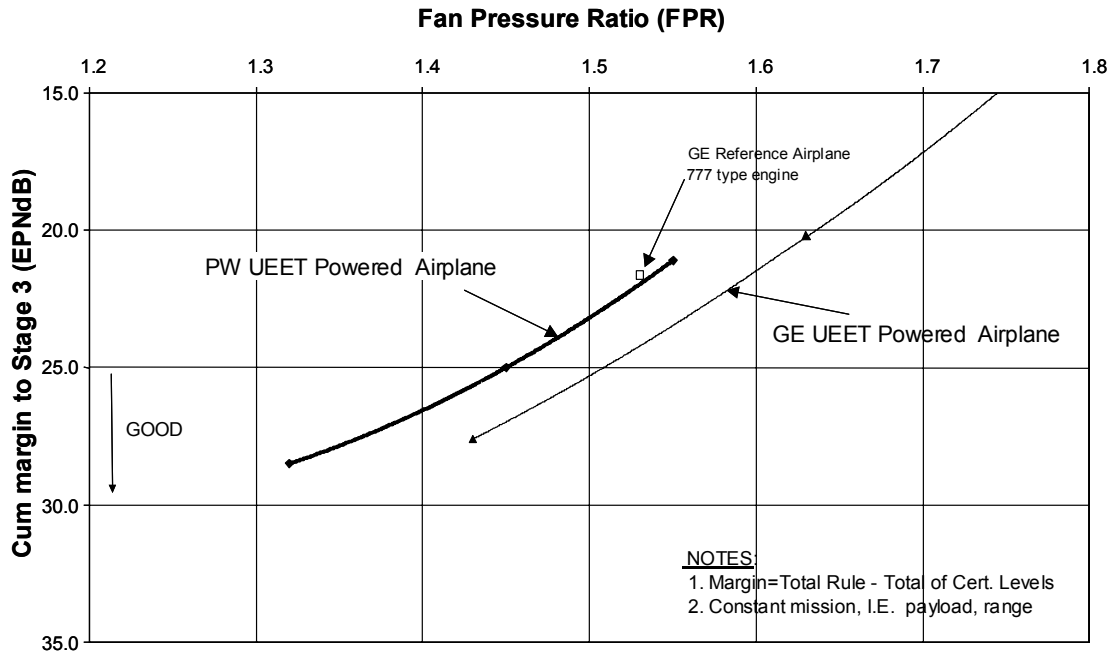

Figure 3.18. Aircraft noise vs. FPR

Figure 3.19 also shows the trend of decreasing noise with decreasing FPR. The chart also illustrates that, for a given FPR, the UEET P&W geared fan engines may be slightly noisier than the baseline PW engine. On geared fan engines, the shorter distance between the fan and the exit guide vane results in increased turbulence and noise. In addition, the shorter length UEET nacelles may result in less area for noise attenuation material to be applied and result in increased noise. However, the overall lower fan pressure ratio available from the use of geared fan design engines will still enable quieter operation over today's higher FPR engines.

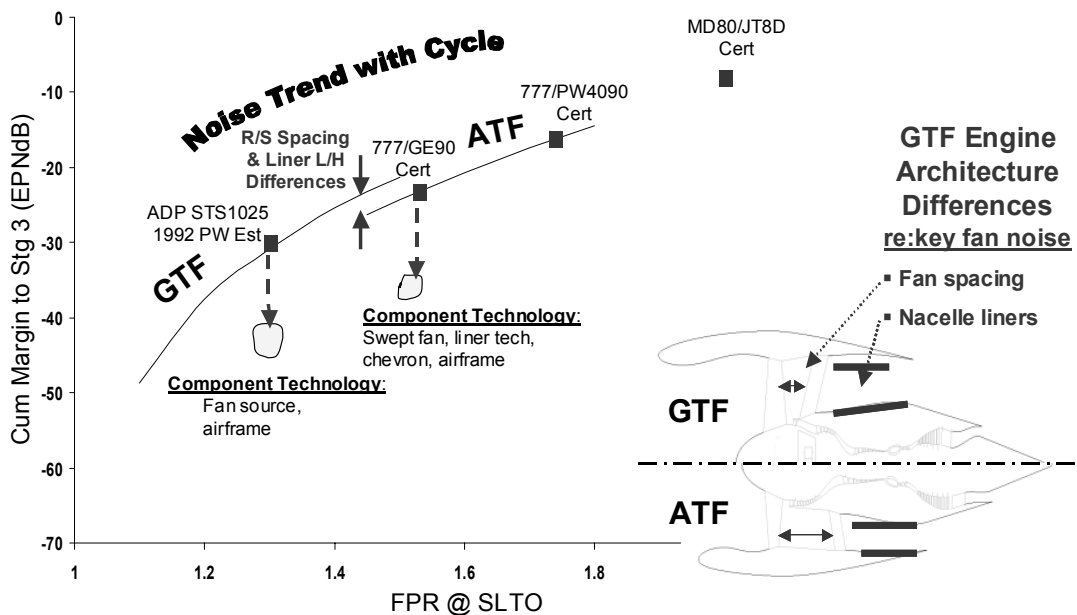

Figure 3.19. Noise design issues for P&W geared fan

As was discussed in section 2.3, the UEET engines have a higher BPR for any given FPR, due to the increased efficiency of the engine cores and the lighter load required to drive the more efficient fans. Thus, when comparing noise to BPR the UEET engines exhibit higher noise levels at similar bypass ratios when compared to conventional technology engines as shown in Figure 3.20. It is also evident that total cumulative noise correlates much better with FPR than it does with BPR.

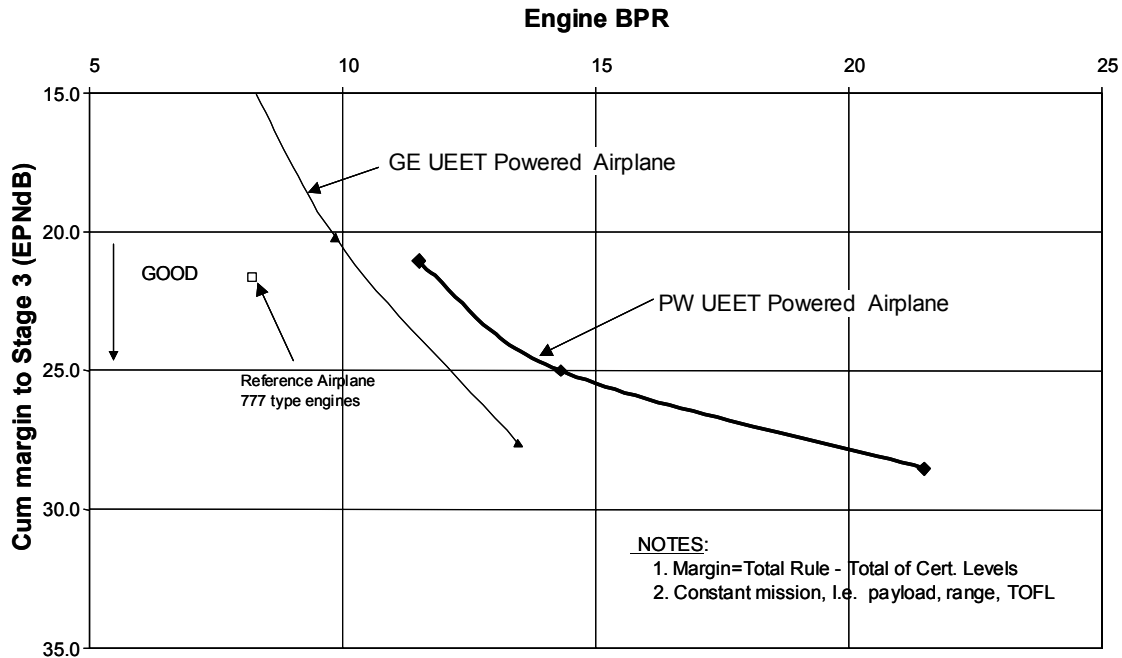

Figure 3.20. Aircraft noise vs. BPR

Figure 3.21 shows the departure and arrival metrics levels used by the London England airports (QC2, QC1, QC 0.5) and some other European Airports versus engine fan pressure ratio for the UEET and reference engines. The departure level shows excellent correlation with FPR as is expected since this metric is dominated by the jet noise component that is predominately determined by FPR for high BPR engines. However, the approach metric for the reference airplane and both the PW and GE UEET engines are each on their own curve. This also is expected as this metric is entirely dominated by fan and airframe noise. Note that the arrival level tends to go asymptotic to a constant level as the FPR is decreased. As the fan noise gets lower the total noise is approaching the airplanes airframe noise level which becomes the noise floor for all engines.

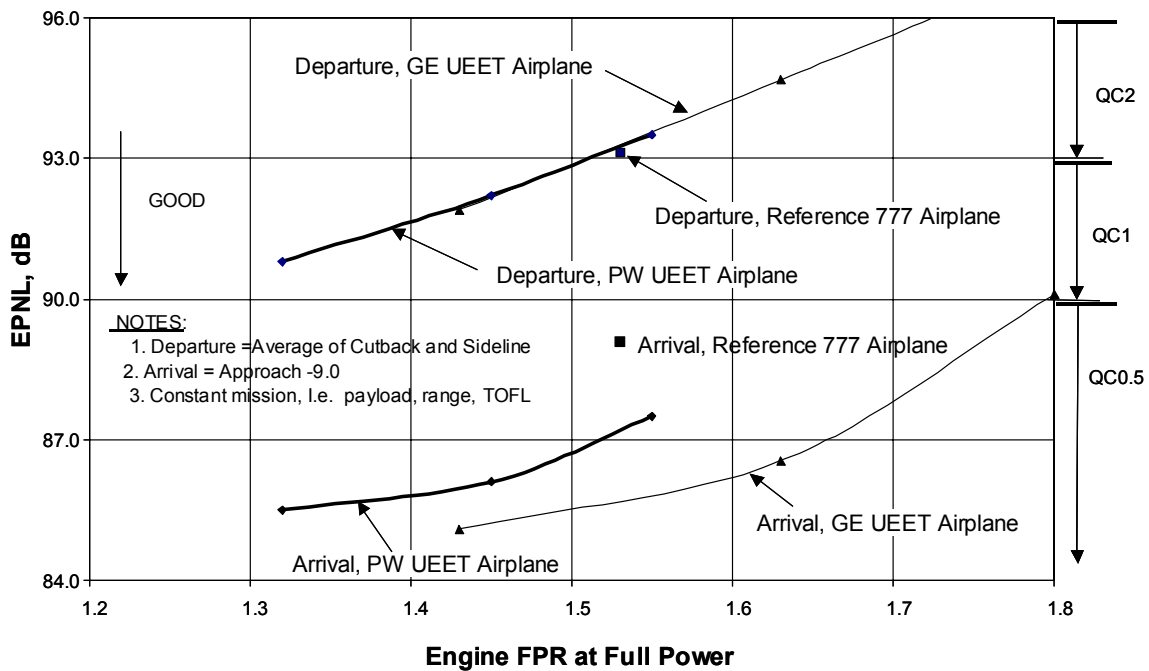

Figure 3.21. UEET Airport Departure and Arrival Noise

It should also be noted that the noise levels determined for all the UEET engines considered only the fan, jet and airframe noise sources which are the only significant sources for total airplane noise when using today's best demonstrated practices. No additional sources were included, particularly rotating machinery interaction tones. These tones have the potential to add significantly to the total airplane noise, particularly with the GE UEET design. Also, as jet and fan noise are reduced by these UEET designs other sources may emerge such as core burner and turbine components.

3.7 Emissions

All of the UEET powerplants used advanced combustor concepts that were intended to reduce oxides of nitrogen (NO_x) during the aircraft Landing Take Off (LTO) cycle. Future evaluations should also include analysis of cruise emissions as this is likely to become another area of regulatory focus.

As engine pressure ratio increases, to improve fuel efficiency, the temperature of the air entering the combustor (T₃) increases. This increased temperature tends to cause NO_x emissions to climb precipitously. Previously, much of the advances in combustor NO_x reduction over the years have been offset by the increasing engine pressure ratios. With the increasing engine pressure ratios, the advanced combustors that were introduced were marginally able to maintain the airplane absolute LTO NO_x emissions. In order to escape this trend of having combustor technology only offset the increases in NO_x caused by engine pressure ratio increases, and truly achieve absolute NO_x emissions reduction, NASA instigated a

low NOx combustor program whose goal was to achieve a 70% NOx reduction from ICAO CAEP2⁽¹³⁾ regulatory limits.

Figure 3.22 shows the CAEP2 limit as plotted against engine sea-level pressure ratio (P&W adjusted for all the same SLS takeoff thrust) and LTO NOx emissions levels. The upward slope of the CAEP2 line illustrates the regulatory allowance made for more fuel efficient engines with higher pressure ratios. The baseline PW4090 and GE90 engines are plotted on the chart showing marginal NOx compliance for both engines. Since the 3 GE UEET engines all have the same pressure ratio and combustor technology, they all fall on top of one another and show they meet the CAEP2 –70% goal level. This data was based on UEET combustor test results. The P&W engines had different pressure ratios and so are each shown at their respective level. The engine with the highest sea level pressure ratio (STF1171) was not able to meet the CAEP2 –70% level, but the other two P&W engines did. This data was extrapolated from test data and adjusted for anticipated emissions reduction improvements with combustor design changes.

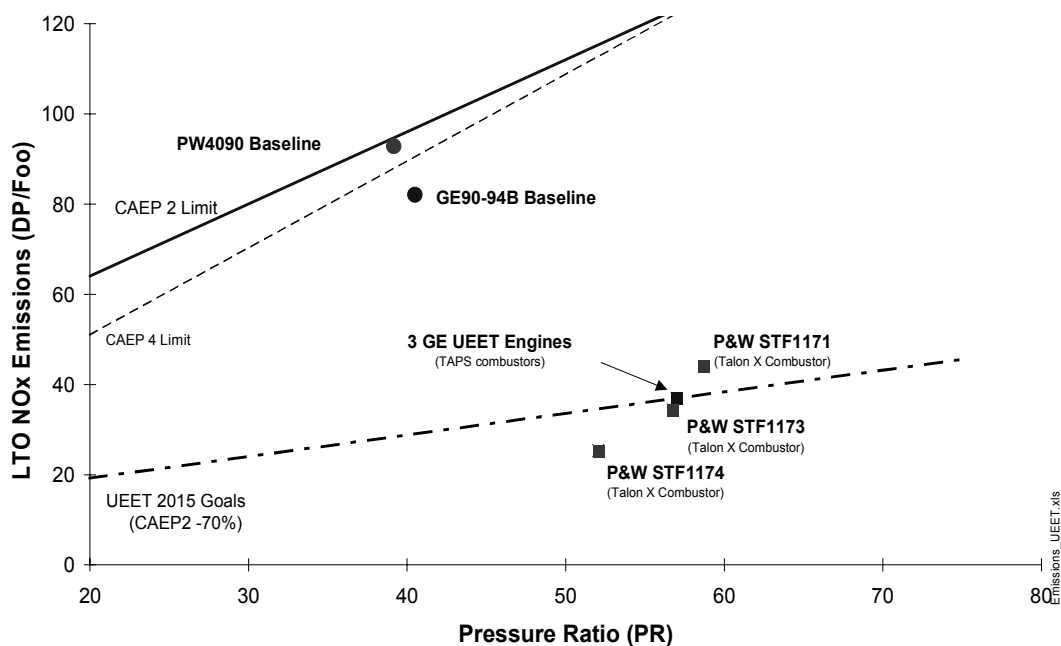

Figure 3.22. Baseline and UEET NOx emissions

Hydrocarbon (HC), Carbon Monoxide (CO) and smoke emissions were not available from Pratt & Whitney. However, HC and CO emissions are shown in Figure 3.23 for the GE and UEET baseline engines. Although HC and CO emissions are higher for the UEET engine, they remain well within reason of the CAEP2 limits.

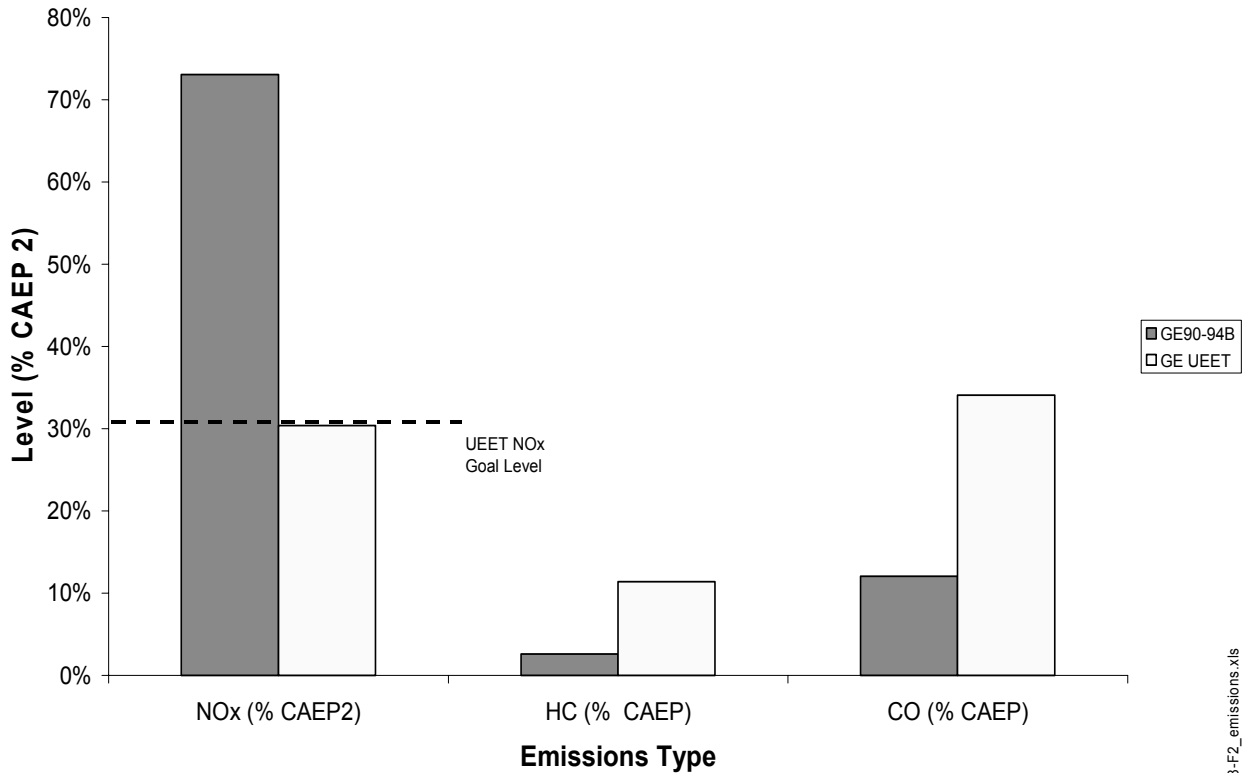

Figure 3.23. GE UEET HC, CO and NOx emissions

The P&W baseline PW4090 engine utilized a conventional Rich-burn Quick-quench Lean-burn (RQL) combustor that had three rows of dilution holes as shown in Figure 3.24. This current production combustor meets CAEP2 levels but will not meet CAEP4 levels and will therefore most likely not be used on future newly designed Boeing aircraft due to its marginal NOx performance.

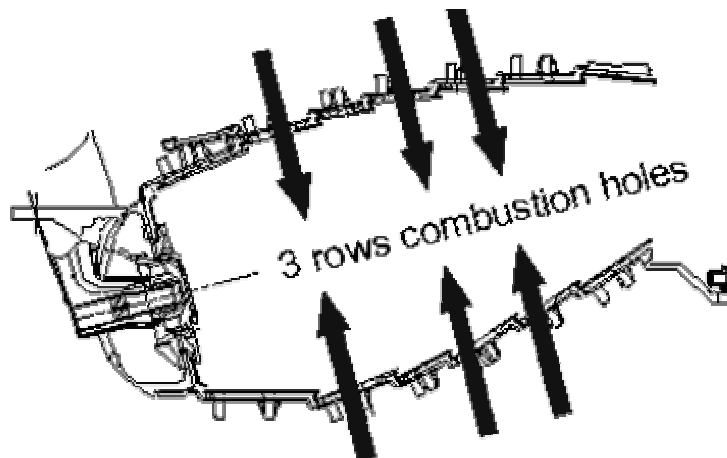

Figure 3.24. Side view of the baseline P&W combustor

For the Pratt & Whitney UEET engine, P&W has utilized specific combustor design features from several follow-on advanced low NO_x Talon combustors. The combustors have evolved from the original Talon combustor concept to the Talon 4 design. Since this newest combustor design is continuing to evolve, it is simply named “Talon X”.

The new P&W UEET combustor shown in Figure 3.25 is also an RQL design, but incorporates better fuel/air mixing in the primary combustor zone. This combustor also includes one row of specially shaped quench/dilution holes to better control the quench process. The Talon X combustor is also smaller which reduces the flame residence time some 30% over the baseline combustor. These enhancements reduce the NO_x emissions level to some 70% below the CAEP2 limit. It does this by well-mixing the fuel into a rich, cool-burning mixture and then rapidly cooling the rich flame into a lean, cool-burning one. This cool burning process minimizes NO_x formation. The fast burning mixture also minimizes the time that NO_x has to form.

This type of quick-quench, lean-burn combustion system tends to exhibit very stable operating conditions (lean blowout). However, a down side to this approach is that these combustors tend to emit higher levels of smoke than lean burn combustors. This may pose a challenge in meeting future regulatory standards.

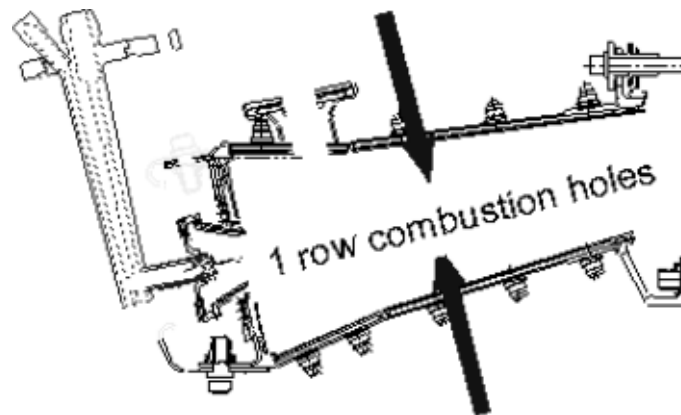

Figure 3.25. Side view of the UEET Talon X combustor

The GE UEET engine uses a different combustor design philosophy of lean, pre-mixed, pre-vaporized (LPP) combustion. This design introduces almost all the combustion air and all of the fuel through an intricate fuel/air swirler nozzle located in the dome of the combustor. The fuel is finely atomized and mixed with the swirling air to form a lean burning flame inside the combustor. This design is called the Twin Annular Pre-Swirl (TAPS) combustor and is shown in Figure 3.26. Since the lean burning flame has no need for additional combustion air, and since the flame is relatively cool, it has no need to be quenched or diluted prior to its exiting the combustor and entering the engine’s turbine section. A new combustor wall design also reduces the amount of cooling air required to further improve the combustion process to achieve a well-mixed, uniform exit temperature profile.

The TAPS design is able to achieve lower NO_x levels than the current lowest GE NO_x combustor, the Dual Annular Combustor (DAC), with less complexity and possibly less operability and maintainability challenges.

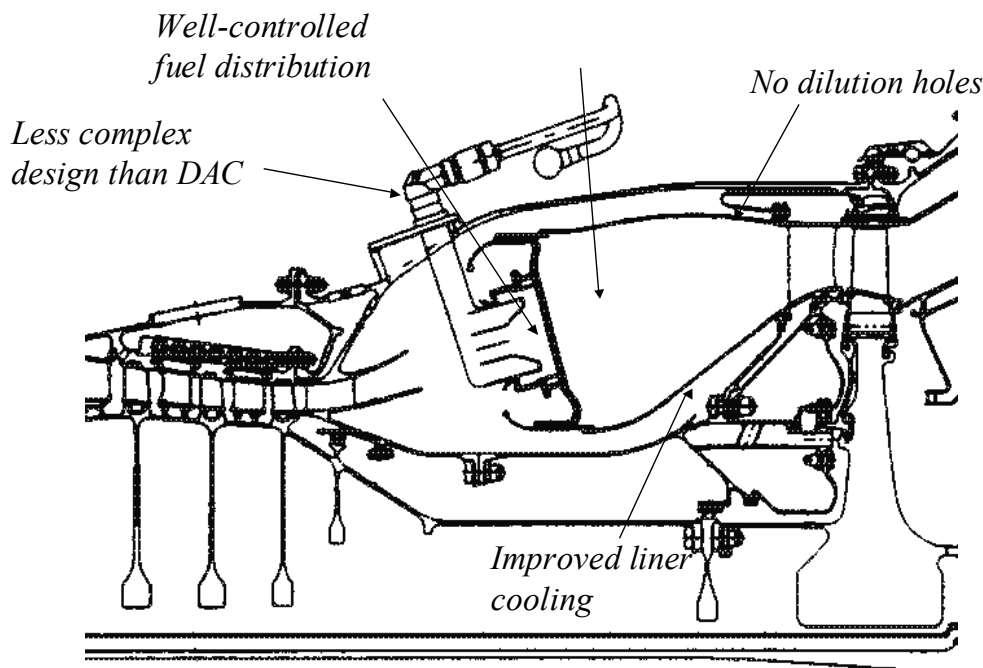

Figure 3.26. Side view of the UEET GE TAPS combustor

4.0 OPTIMAL CONFIGURATIONS

The optimal engine configuration for both GE and P&W engines are presented below. In the considering the optimal engine size, the design analysis metrics in section 3.0 are included. However, the optimal engine is ultimately the one that provides the lowest mission fuel use and minimum operating cost. Emissions and noise were considered secondary design optimization points for this study.

4.1 Engine/Airframe Sizing

Several design iterations are required to optimally size an engine for an aircraft. First, the performance for an airplane and the resulting engine need to be estimated and the engine requirements passed on to the engine supplier. Second, the airplane will be configured with the supplied engines. Next, the airplane performance will be checked to see if it meets the performance requirements. The engines will then be adjusted to enable the airplane to meet the performance requirements. The airplane can then again be re-designed for the final engines.

Based on a previous airplane study, the estimated thrust requirements throughout the aircraft mission (takeoff, climb, top of climb, end of cruise), cruise speed, cruise altitude, and anticipated SFC ranges were issued to both GE and P&W. The engine companies were then to each supply three engine designs along with engine performance and emissions information. This information was formatted to develop engine data modules for use in the airplane analysis program GCASES.

The baseline study airplane, as described in section 2.2, was fitted with each of the UEET engines. Because each of the engines had the same Boeing equivalent thrust but different size fan diameters, the airplane had different performance characteristics. In order to achieve the same minimum performance across the engine lines the engines were then resized to meet the ground rules spelled out in section 1.3.

The two performance parameters most affecting the sizing of the engines were Take-Off Field Length (TOFL) and top of climb performance. The smaller BPR engines were generally most challenged by TOFL while the large engines were most challenged by top of climb thrust requirements. This has to do with the higher thrust lapse rate of the large diameter engines -- higher BPR engines have more thrust at sea level conditions than at high altitude.

Figure 4.1 shows the static sea level thrust versus engine fan diameter for the originally supplied UEET powerplants and the resized engines. Each of the resized engines required more thrust than the original supplied ones from GE and P&W. In the resizing each engine, the FPR, BPR, OPR, T/W, and SFC were kept the same as the originally supplied engine.

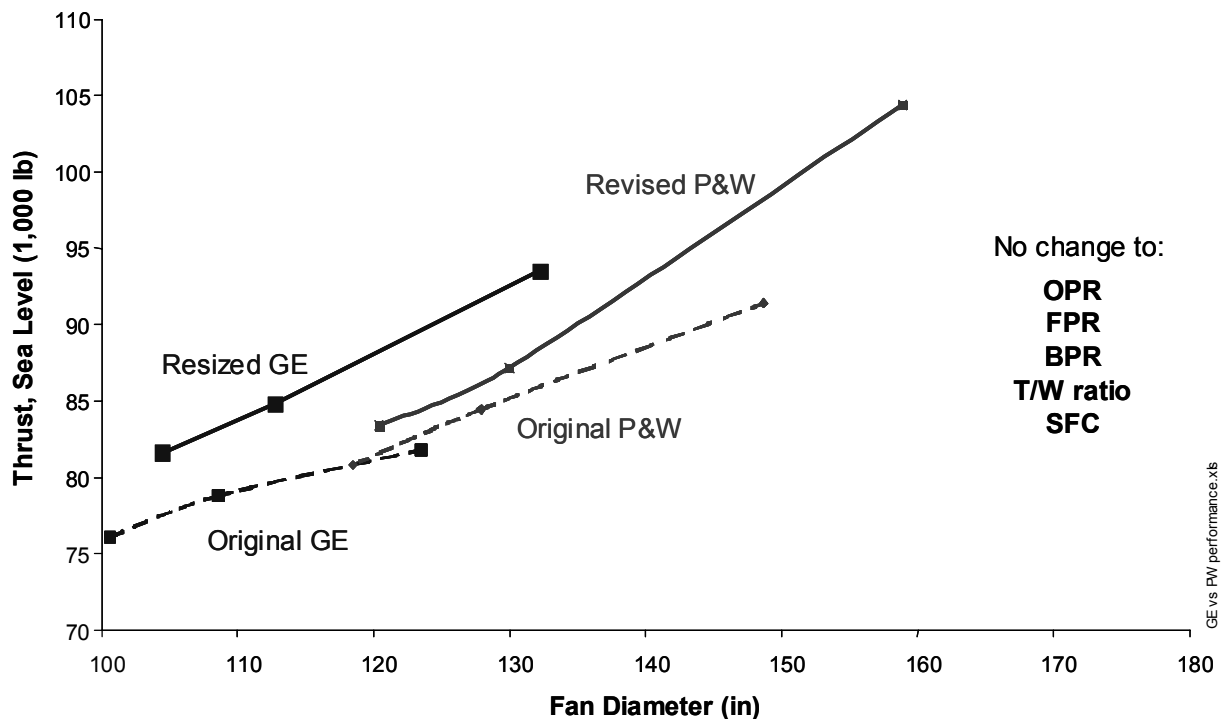

Figure 4.1. Resized UEET powerplants to meet thrust requirements.

A comparison of the engines before and after resizing is also shown in Table 4.1. These data were adjusted for consistent bookkeeping between engines and nacelles.

Table 4.1. Original and revised engine data

Original Baseline Engines			Pratt & Whitney			General Electric		
Engine	GE 90-95B	PW4090	STF 1171		STF 1173	GE58-F2-B7	GE58-F2-B6	GE58-F2-B5
Description	turbofan	turbofan	turbofan	geared fan	+VAN	Advanced turbofans ... all same technology		
Fan Dia (in)	123	112.9	118.5	127.9	148.7	100.6	108.6	123.5
Thrust, SLS (lb.)			80,820	84,453	91,400	76,100	78,800	81,800
Thrust, BET (lb.)	93.7	90	78,800	78,800	78,800	76,500	76,500	76,500
BPR	7.8	6.2	11.5	14.3	21.5	7.43	9.47	13.1
OPR	40.5	40	68.7	74.3	78.8	57	57	57
Resized Engines								
Fan Dia (in)			120.4	130	158.9	104.5	112.8	132.8
Thrust, SLS (lb.)			83,383	87,217	104,350	81,610	84,832	93,500
Thrust, BET (lb.)			81,300	81,400	89,300	82,100	82,200	87,500
BPR			11.5	14.3	21.5	7.43	9.47	13.1
OPR			68.7	74.3	78.8	57	57	57
						Rons_EXCL Fgs.xls		

The engine resizing exercise in GCASES included resizing the vertical tail to maintain the same minimum ground control speed with an engine out. This was done by adjusting the vertical tail volume by the engine out yaw moment compared to the baseline. Takeoff thrust on one engine and wind milling drag on the other at Mach 0.20 were used.

The study included effects of engine diameter on the required landing gear length. The configuration design requirement is to preclude the nacelle striking the ground in the event of a collapsed main or nose gear. This design requirement (to avoid nacelle damage) is for safety and cost reasons. Nacelle damage could result in engine failure. In particular, if it resulted in an uncontained rotor burst, this would present a significant hazard to the airplane's occupants and is to be avoided.

Shortening the landing gear was not considered since it would reduce the rotation capability of the airplane and degrade take-off capability.

As five of the six UEET powerplants had smaller, or the same, engine diameters as compared to the larger current baseline engine on the 777-200ER (GE90-94B with 123in diameter), less work was required for integrating these engines. However, for the largest P&W engine, (STF1174), integration difficulties required a more in-depth study as will be discussed in section 4.2.

4.2 P&W powered airplane

Integration of the three UEET P&W engines (STF1171, STF1173 and STF1174) onto the baseline is discussed below.

Without modifying the wing or landing gear on the baseline airplane, the engine nacelle ground clearance for the largest diameter engine (STF1174) would have all but disappeared as shown in Figure 4.2.

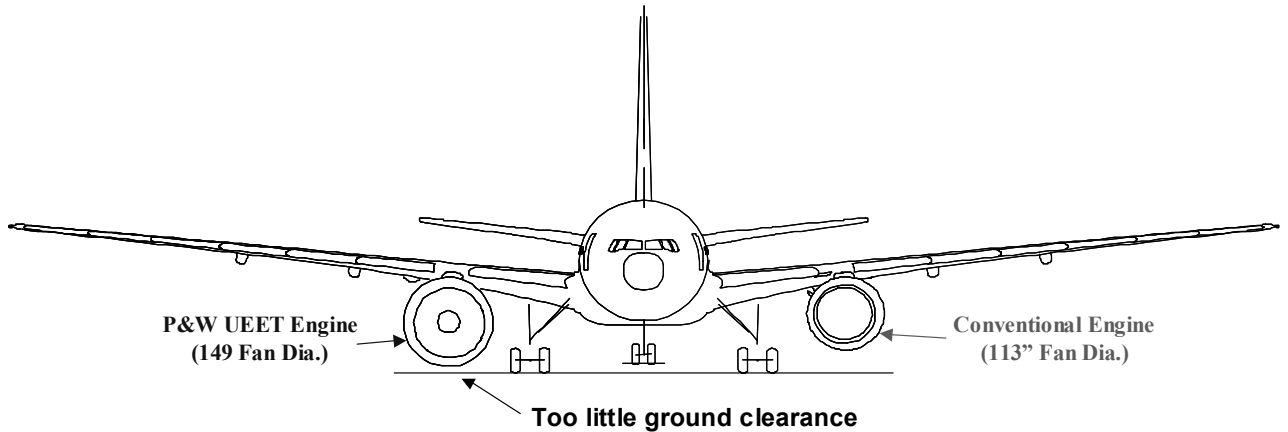

Figure 4.2. Comparison of STF1174 and PW4090 on 777-200ER airplane

For the STF1174 engine, the landing gear needed to be lengthened. However, if only the landing gear were lengthened, the height of the passenger door sills would have increased to the point that new ground handling equipment would have been necessary. In order to prevent this scenario, the landing gear was lengthened to the maximum point where existing ground service equipment could still be used and the wing was then sheared so that the aircraft engine would have the same ground clearance as the existing largest diameter engine (GE90-115B). The landing gear was lengthened 4.7in while the wing was sheared 15.3in. This gull-wing type configuration enabled the engine to achieve satisfactory ground clearance while also minimizing weight. Wing shear is facilitated by the composite wing design which would allow a smaller skin compound bend radius, currently limited on metal wings. It is also anticipated that wing shear on the composite wing will have little or no adverse impact on weight and manufacturing cost. Figure 4.3 shows the final installation scheme for the STF1174 engine on the left side of the illustration as compared to the baseline PW4090 engine on the right.

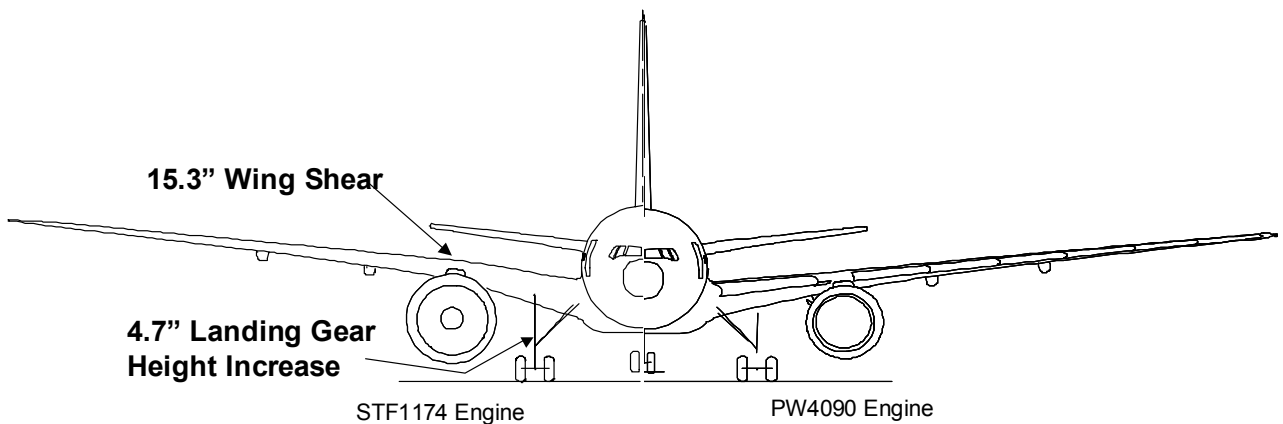

Figure 4.3. STF1174 vs. PW4090 with wing shear and landing gear increase.

Another factor in selecting the length of the landing gear is the nose gear collapse scenario. The engine nacelle should not be damaged in this event and the engine case itself must not be damaged. It was found that lengthening the gear did not allow the nacelle to escape damage, but the engine would not be damaged as show in Figure 4.4.

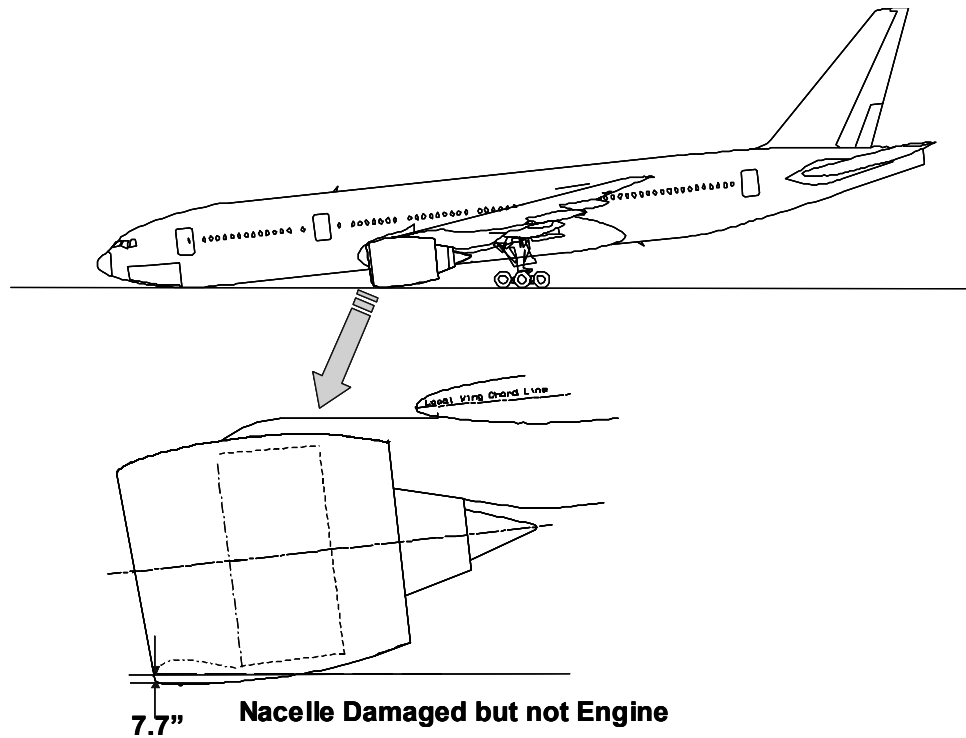

Figure 4.4. Nose gear collapse with STF1174 engine.

The installation scheme, showing engine ground clearance and nacelle crush limits, for all of the P&W engines is shown in Figure 4.5.

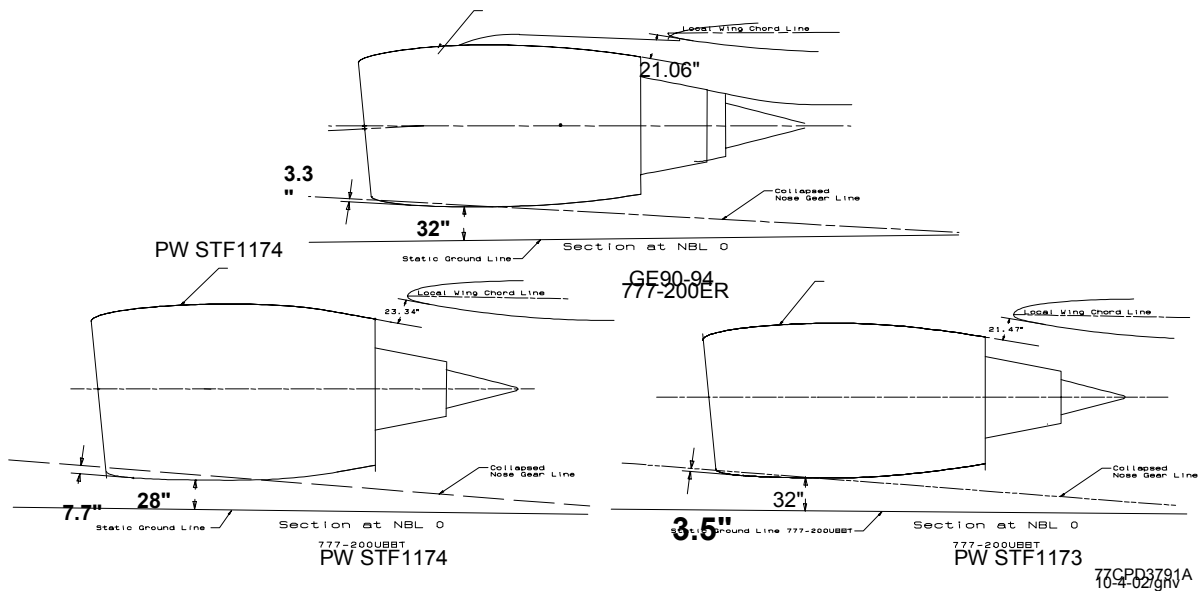

Figure 4.5. P&W UEET powerplant side view installation

When the landing gear is lengthened, weight of the landing gear will increase about 100 lbs per inch of length or 470 lbs. for the study airplane. Longer escape slides will then be necessary and the weight of these should increase about 100 lbs for a 4.7in longer gear as shown in Figure 4.6.

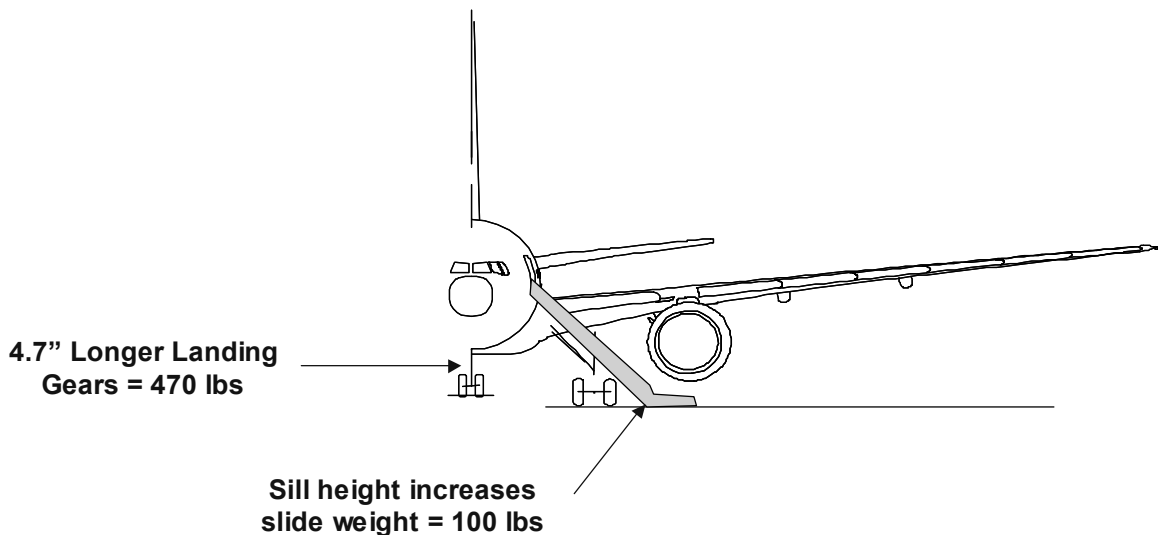

Figure 4.6. Weight increase for landing gear and slides with STF1174 engine.

In the event of an engine out condition, for larger diameter engines, windmill drag increases were as discussed in section 3.2. This increased drag will cause the airplane to yaw towards the inoperative engine and will need to be compensated for by increased rudder action to return the aircraft to straight flight. Figure 4.7 shows the factors determining the resizing of the vertical stabilizer and rudder to account for the large diameter UEET powerplants. The airplane's yaw moment was determined by calculating the windmill drag of the inoperative engine and the yaw caused by the thrust of the remaining operating engine. The windmill drag was found to be higher for all of the UEET engines as compared to the baseline 777-200ER engines. However, the takeoff thrust for the UEET powerplants was lower due to the lighter takeoff weight of the airplane, so the proportion of windmilling drag to available thrust was increased. This required a larger vertical stabilizer and rudder for all of the P&W engines, with the largest diameter P&W engine requiring a 15% larger tail.

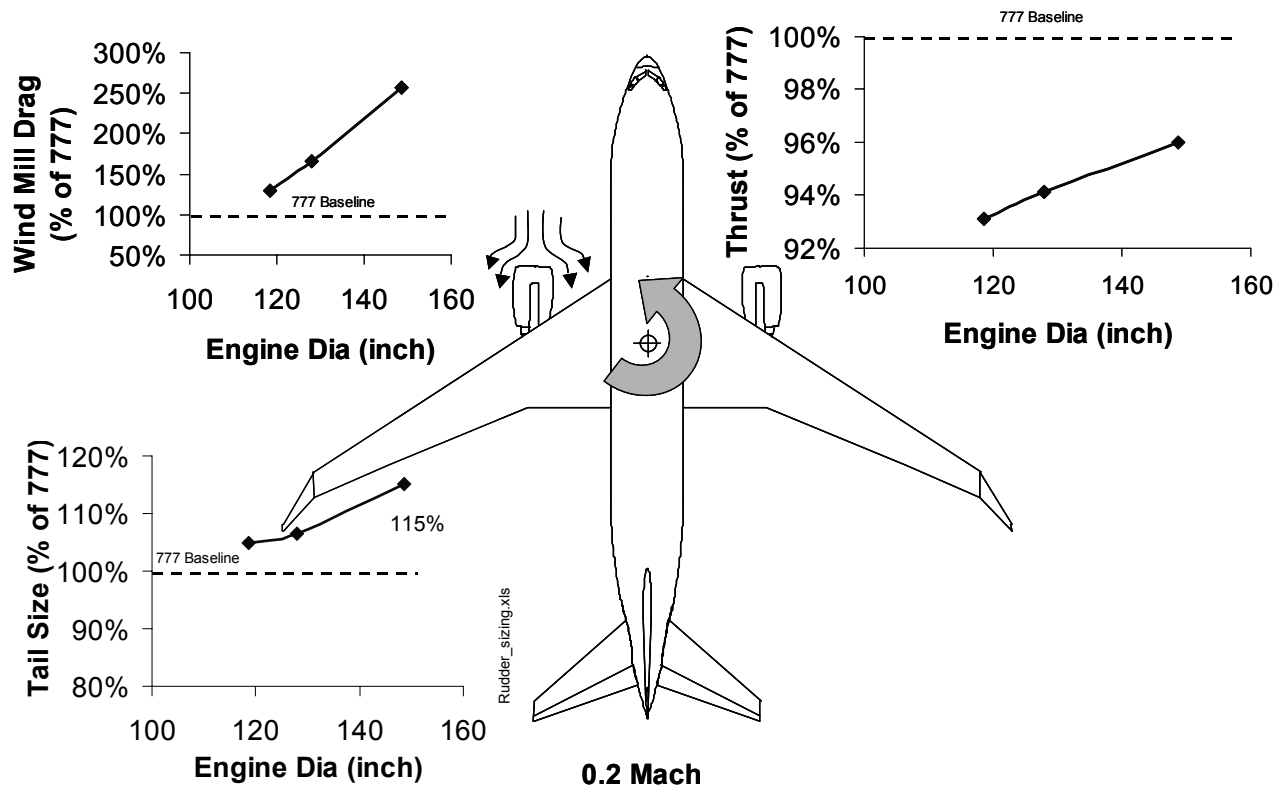

Figure 4.7. Vertical tail sizing with P&W UEET powerplants

The STF1174 engine utilized a core mounted, petal thrust reverser. Maintaining a compact, light-weight, low-drag reverser is needed to achieve the benefits of the very high by-pass ratio engines. However, the effectiveness of this new design seemed to be less than current technology engines. For this study, it was assumed that the airplane and large diameter engine combination would enable a lower effectiveness thrust reverser to be used due to the lower level of retarding force needed with these large diameter engines. However, the stopping distance on

slippery runways needs to be assessed and reverser requirements more clearly defined. In addition, when extending the length of the nacelles, to reduce drag as discussed in section 3.2, the area available for mounting the petal reversers decreased. This design tradeoff also needs to be further addressed.

Figure 4.8 shows the installation scheme for a baseline engine along with two P&W UEET engines onto the baseline airplane. The aircraft on the bottom of the illustration utilizes the largest diameter engine (STF1174).

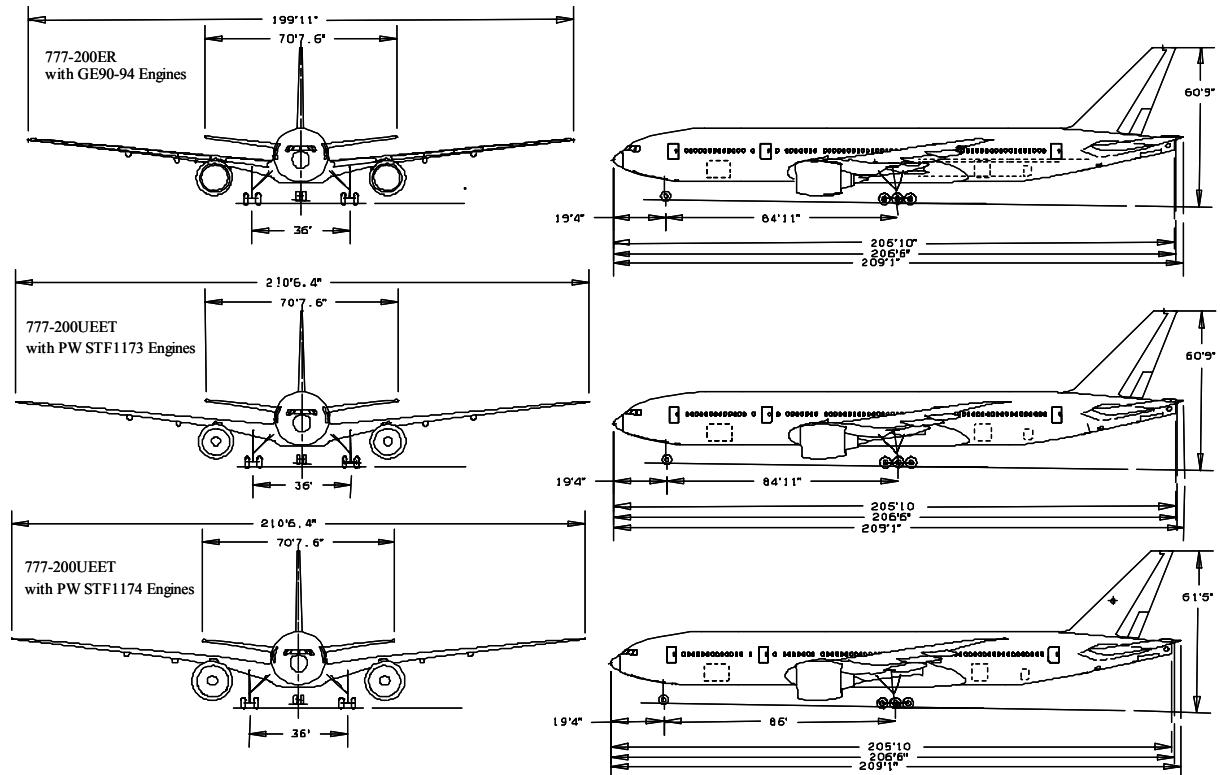

Figure 4.8. P&W UEET powerplant integration

Figure 4.9 shows the downward trend of engine SFC when plotted against engine bypass ratio for the three P&W UEET powerplants. It also shows the airplane fuel use on a 3,000 nmi mission, with 70% passenger load factor for the three engines. The engine with the best SFC is the largest diameter, highest BPR engine—the STF1174. However, when the engines are installed on the aircraft, the optimal sized engine (for fuel use) is the medium fan diameter, BPR engine—the STF1173. This optimal sized BPR engine is significantly larger than the optimally-sized baseline PW4000 series engine. This engine achieved a 15.79% reduction in block fuel use as compared to the baseline advanced technology airplane with PW4090 engines.

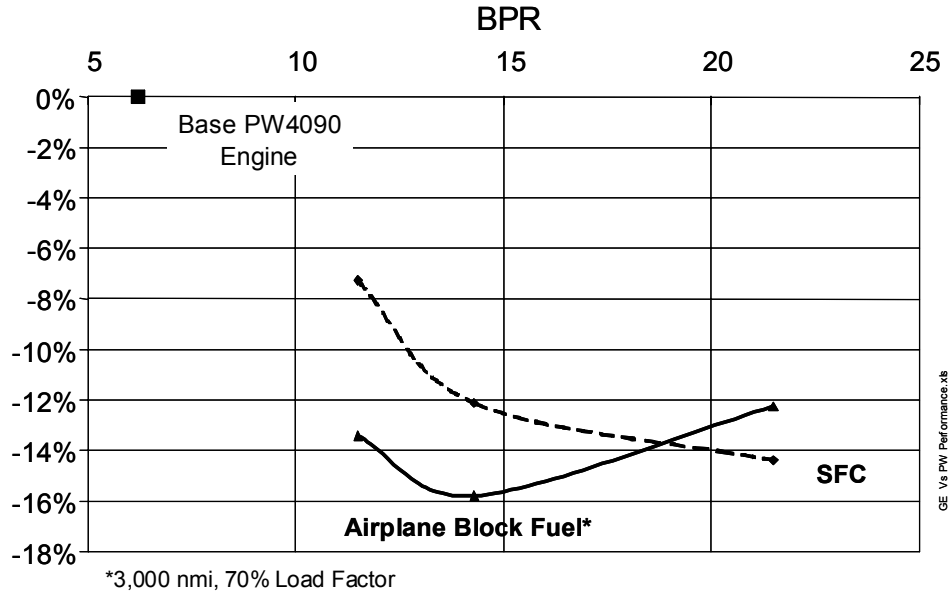

Figure 4.9. P&W UEET fuel use

As operating cost was also a consideration in the study, Figure 4.10 shows the Cash Airplane Related Operating Cost figures for the three P&W engines installed on the 777 with composite wing. The results show that of the three engines, the STF1173 with BPR of 14.3, and Fan Dia. of 127.9in provides the minimum CAROC relative to the other P&W engines. This includes cycling effects that meet mission requirements of engine thrust and tail volume, increased gear length and accounts for wing shear. This trend assumes the technology effects vary uniformly, which is not necessarily the case with the P&W Geared Fan (STF1173, 1174), ATN, VAN and Thrust Reverser technologies (STF1174 only).

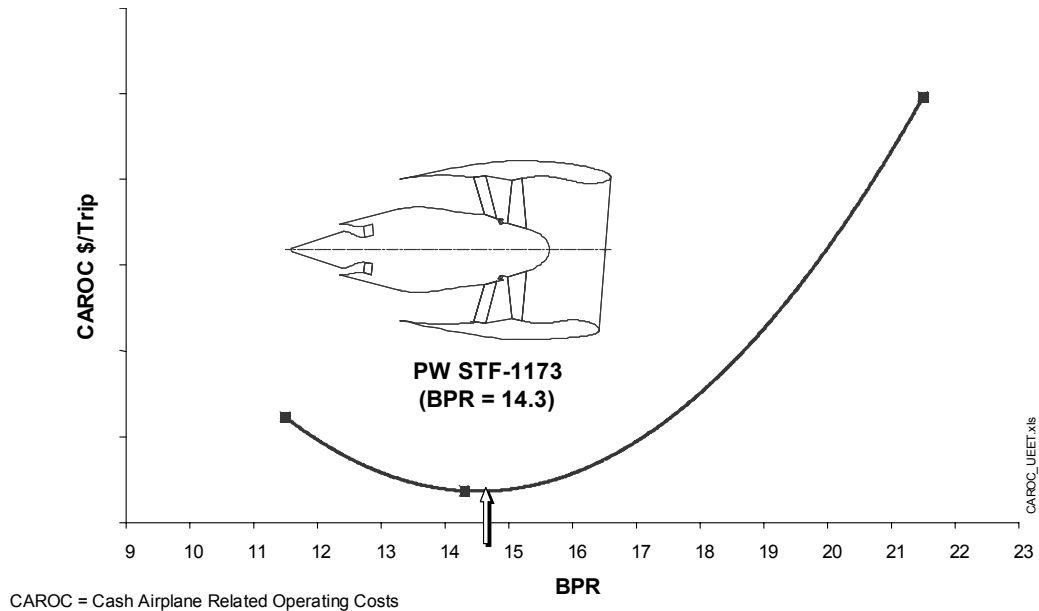

Figure 4.10. P&W UEET economics

4.3 GE powered airplane

Most of the GE engines did not require gear lengthening or added wing shear in order to integrate the engines due to the smaller or equal overall engine diameter. To minimize drag, the engines were located such that the aft part of the fan cowl was located slightly ahead of the wing leading edge. The distance between the fan cowl and the underside of the wing (gully height) was also held constant for the GE engines.

Figure 4.11 shows the engine SFC and airplane block fuel use for a 3,000 nmi mission, 70% passenger load factor for all three GE UEET powerplants as compared to the baseline airplane with GE90-94B engines. As with the P&W UEET powerplants, the minimum engine specific fuel consumption was for the largest sized fan diameter (largest BPR) engine. The trend continued for the airplane block fuel use as well – the medium sized fan diameter engine achieving better block fuel use than the largest diameter engine.

Some question remained as to whether the medium-size engine presented the best results, or if an engine between the medium and large-size fan engine would offer further block fuel improvement. Thus, assuming the SFC trend shown in figure 4.12, and that a similar trend could be established for weight and drag, another iteration was performed on the airplane for a re-designed engine with a BPR of 11. It showed that this engine did indeed achieve lower block fuel use than the 9.5 BPR engine supplied by GE. Thus, the block fuel use curve illustrated in Figure 4.11 is correct in stating that the block fuel consumption bucket lies somewhere between 9.5 and 13 for the GE UEET powerplants. This is higher than the traditional optimal BPR of 9 for current technology engines.

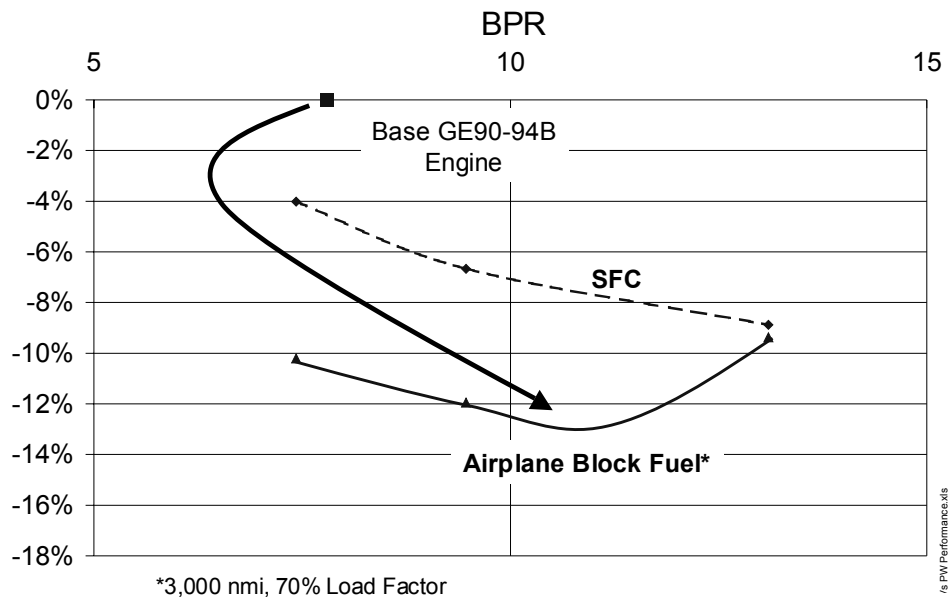

Figure 4.11. GE UEET fuel use

The Cash Airplane Related Operating cost similarly follows the P&W CAROC trend of reaching a minimum at the minimum block fuel use. Figure 4.12 shows the minimum CAROC to fall around a BPR of 11.

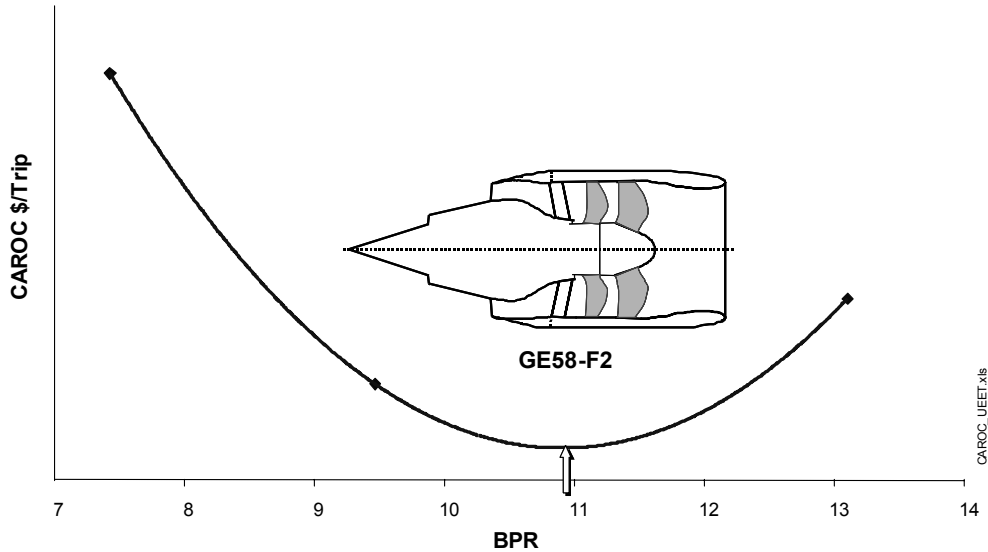

Figure 4.12. GE UEET economics

Although the optimal P&W UEET engine achieved lower fuel use than the optimal GE UEET engine, the GE engine was slightly lighter in weight. Weight plays a factor in the CAROC calculation, and so the P&W engine was penalized for this weight. When considering both fuel use and weight, the GE engine matched the P&W engine in overall CAROC values as shown in Figure 4.13.

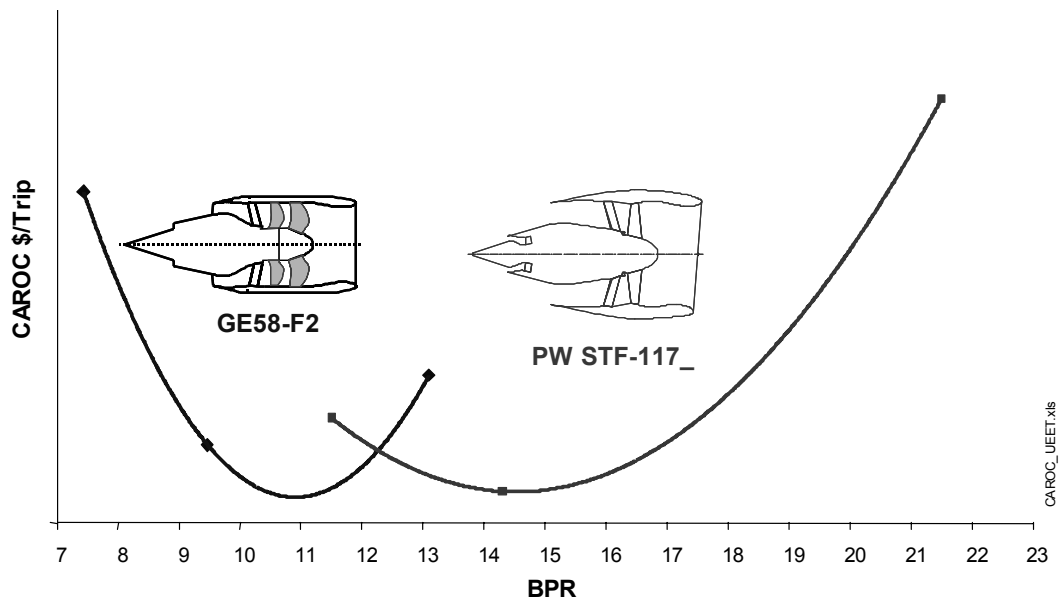

Figure 4.13. GE and P&W CAROC

4.4 Optimal BPR for larger and smaller airframes

This study also resulted in the issuance of a subcontract to Tuskegee University in Alabama to investigate the differences in engine sizing criteria for smaller and larger airframes.

The medium sized, 305 passenger, 777 has been used in several past configuration studies as it represents the newest Boeing technology airplane and also serves as a good, unconstrained study platform for this type of engine diameter work. However, it will be desired to apply UEET powerplants across the market range to differently sized airframes. Thus, a sensitivity study was performed to determine if the results of this study can be carried through to smaller and larger aircraft. The sizes investigated were:

- 1) small 162 seat, 24,000 lb thrust class airplanes
- 2) medium 305 seat, 88,000 lb thrust class 777 (to compare with the baseline).
- 3) large 403 seat, 120,000 lb thrust class low wing twin engine airplane

GE and P&W engine data was not supplied to Tuskegee. Rather, Boeing generated data to represent advanced technology engines similar in performance to the UEET engines. This engine data was consistent with the P&W UEET engine weights and efficiencies, and were scaled for the larger and smaller thrust classes using a public-domain engine database by Charlie Svoboda.⁽³⁾ Aircraft integration used the same ground rules as was done for the 777-sized baseline aircraft, except that the analysis was performed by using level 1 relationships as defined by the Roskam Airplane Design method⁽⁶⁾ and that contained in the automated Advanced Aircraft Analysis (AAA) design software.⁽⁵⁾ The AAA design software and the engine data produced by using it were calibrated by first generating a medium-sized, 305 passenger airplane. These results were then compared to the results from the Boeing study to assure consistent engine BPR optimization results.

Tuskegee University used the process outlined in Figure 4.14 to find the required thrust levels for the UEET engines. The airplane thrust-to-weight ratio was kept constant for each type of aircraft. The vertical tail was sized at the new thrust level using two different criteria—windmilling drag and constant tail volume coefficient. The vertical tail was sized to the larger of these two values. In most cases, the windmilling drag criteria yielded a larger vertical tail area.

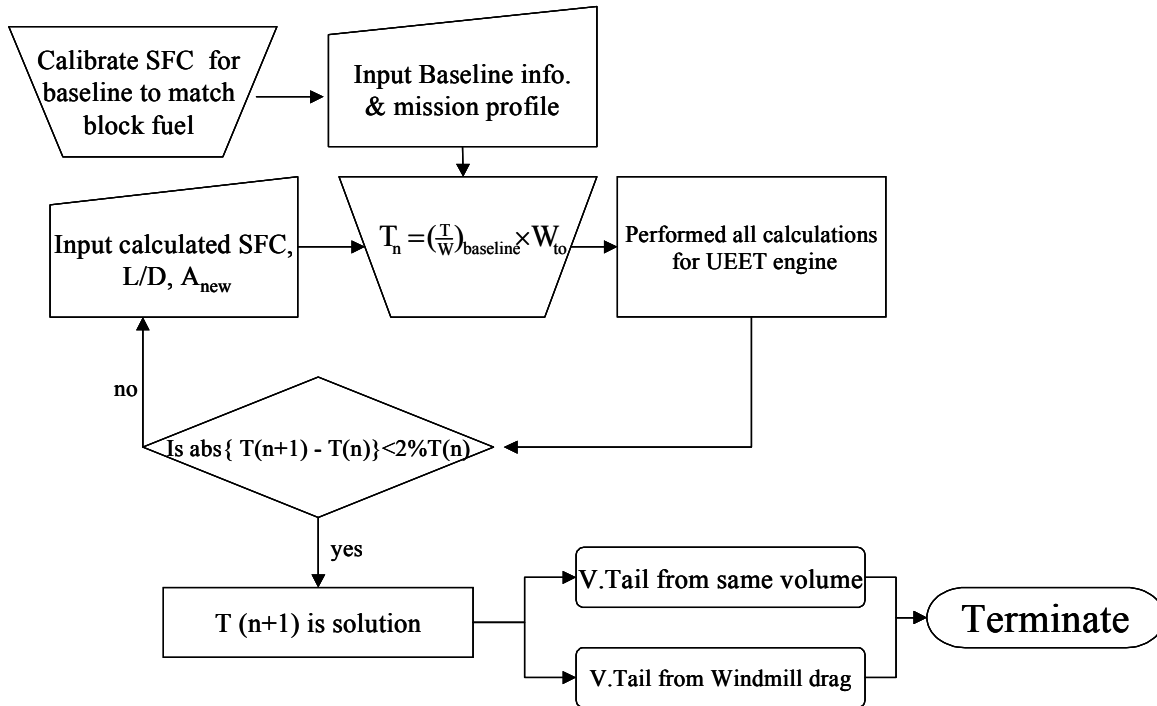

Figure 4.14. Tuskegee process for determining required trust

4.4.1 Smaller Aircraft BPR drivers

The small aircraft used for this study was based on a Boeing 737-800 aircraft as shown in Figure 4.15. However, the wing planform was replaced with a composite wing with a reduced area of 1250 sqft. The MTOW and OEW for this baseline airplane were also reduced to account for the composite wing.

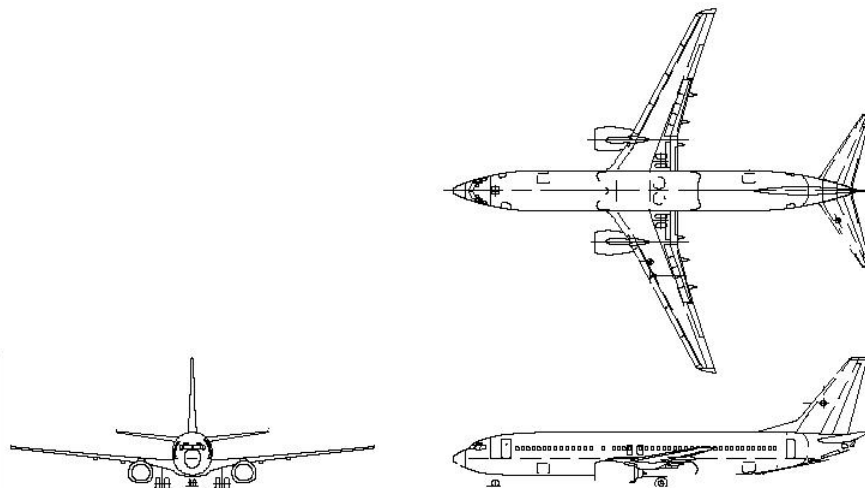

Figure 4.15. Small study aircraft three-view

The specifications for the baseline airplane engine and the three advanced technology study engines are shown below in Table 4.2. The engine thrust levels decrease with increasing BPR because with the more fuel-efficient engines, the MTOW of the resized airplanes decreased which led to lower thrust requirements.

Table 4.2. Small aircraft engine data

	Baseline	Engine 1	Engine 2	Engine 3
Thrust (lbs SLST)	24,000	22,400	21,800	22,600
BPR	5	11.5	14.3	21.5
Approx. Fan Dia. (in)	62.5	64.1	68.3	80.6

The primary factors involved with implementing UEET engines on a small airframe include: engine ground clearance, gear length, and vertical tail area. The minimum ground clearance for the engine is 18in. The windmilling drag on the large engine also leads to larger vertical tail areas.

Engine 2 was determined to be the optimum engine for the 737-sized airframe. This 14.3 BPR engine provided the best balance of efficiency without having a fan diameter that was too large to be accommodated by the airframe. Engine 3 had a better SFC, but the large fan diameter required a longer landing gear length that added weight, and larger vertical tail areas which added to significant excrescence drag increase. The result is surprising considering that smaller airframes in service typically have smaller BPR engines,⁽³⁾ driven by the limited time spent in cruise.

To verify this result would require a full engine deck analysis to identify the actual mission element fuel burns. This result assumes the relative delta fuel burn engine-to-engine would remain similar to this analysis.

4.3.2 Larger Aircraft BPR drivers

The large aircraft for the Tuskegee study was a conceptual 777 design. This aircraft is significantly larger than the present 777-200 and served as the baseline for the large engine study. The three-view is shown in Figure 4.16.

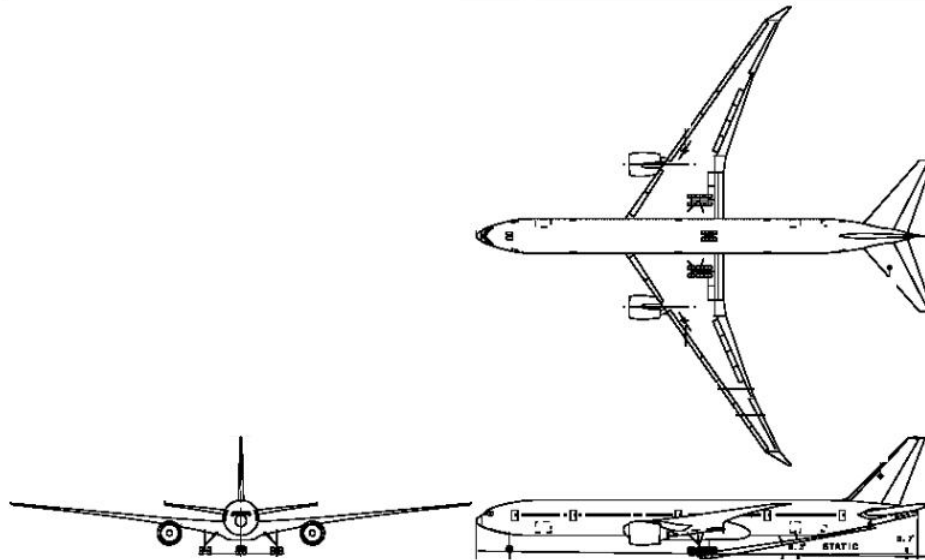

Figure 4.16. Large aircraft three-view

The specifications for the baseline engine and the three advanced technology engines (similar to the P&W UEET engines) are shown in Table 4.3. The bypass ratios are the same as the UEET engines for the small aircraft case. While the bypass ratios are constant, the fan diameter is scaled using factors derived from the database by Svoboda.⁽³⁾

Table 4.3. Large aircraft engine data

	Baseline	Engine 1	Engine 2	Engine 3
Thrust (lbs SLST)	120,000	105,000	99,000	100,800
BPR	9	11.5	14.3	21.5
Fan Dia. (in)	137.1	135.5	141.9	80.6

Engine 2 was again found to be the optimum engine for the large aircraft case. Although the difference between the Engine 2 and Engine 3 performance was less than in the case of the small aircraft, Engine 2 resulted in a slightly better fuel burn and was therefore selected as the optimum engine. The primary driver for this decision was vertical tail size, and engine drag. Engine 3 had a very large fan diameter, but it still met the minimum ground clearance of 29in due to the gear length being sized by the long body length rotation angle. Thus, the gear did not need to be lengthened for any of the engines. The large diameter did contribute to increases in windmill drag and the vertical tail area. Therefore, Engine 3 resulted in a slightly higher OEW and corresponding MTOW than the Engine 2 case. The difference was small enough to suggest a review of other drivers, such as noise and emissions.

5.0 CONCLUSION

UEET powerplant improvements result in major reductions in SFC and engine weights. When installed in airframes that were resized to achieve the same mission performance, fuel use reductions of 15 to 16% were estimated. The fuel use reductions translate directly into emissions reductions that are then further reduced by the advanced combustor technologies. The optimal GE (1.57 FPR) and P&W (1.45 FPR) UEET powerplants both exhibited fan pressure ratios that were in the range of the current technology baseline engines ($1.46 \leq \text{FPR} < 1.6$). The P&W variable area fan nozzle technology, that enabled the use of even lower fan pressure ratios (with corresponding improved propulsion efficiency), was not required due to the fact that the larger nacelles increased airplane drag and offset much of the engine fuel efficiency improvements.

The optimal GE UEET engine fan diameter was smaller (115in) and the optimal P&W UEET engine fan diameter was larger (128in) than their respective current technology baseline engines. This fan diameter difference is due to the design differences between the two engines—GE counter-rotating dual fan versus P&W single geared fan.

Both of the UEET powerplants exhibited substantially larger bypass ratios than their current technology counterparts. This is due to the increased efficiency and higher power output of the engine cores. It is also no doubt due to the increased efficiency of the fan designs, requiring less power to drive the fan for any given thrust level. The increased engine core capability, and less output power required for the fan, results in less air being used by the core which in turn increases the BPR. The UEET powerplants exhibit larger optimal bypass ratios than have traditionally been found for current technology engines (around 9). Both P&W geared fan (14.5 BPR) and GE advanced technology engines (11.0 BPR) have different optimal BPR design points.

Limited engine performance data suggests that noise levels are expected to be about the same with the UEET engines as with conventional engines due to the similarity in FPR, which is an indicator of fan jet velocity and resulting noise.

NO_x emissions are expected to be substantially reduced over the baseline engines due to the use of advanced combustors. HC & CO emissions will climb slightly due to a tradeoff of reduced NO_x emissions.

Although the optimal P&W UEET engine achieved about 2% better absolute airplane fuel efficiency than the GE UEET engine, the operating cost is the same as the GE UEET engine due to weight accounting penalties associated with the P&W UEET engines in the calculation of CAROC.

The same BPR versus block fuel use tradeoff seems to exist for smaller and larger aircraft, in that medium sized fan diameter engines appear to be the best choice for reduced fuel use and operating cost (Figure 5.1). Optimal engines for very large aircraft have yet to be determined, but the trend is expected to continue.

This study helped to quantify the benefits of UEET powerplants, found optimal bypass ratios for the given engine cycles, indicated the results were consistent over a large range of platform sizes, and determined the key technologies that are of most value to pursue for future aircraft.

It is recommended that follow-on studies apply a probabilistic method, such as the Georgia Tech Technology Metrics Assessment and Tracking process (TMAT) or a Technology Identification and Evaluation Selection (TIES) methodology, to obtain a more accurate optimum and to identify the full technology set required to support the optimum airplane design.⁽¹¹⁾ Critical to that analysis will be a uniform study engine that can be varied in the region of interest to better define the shape of the fuel burn/CAROC variation. The engines used in this study have assumptions that were not fully consistent between engine companies, or between given engine BPR's.

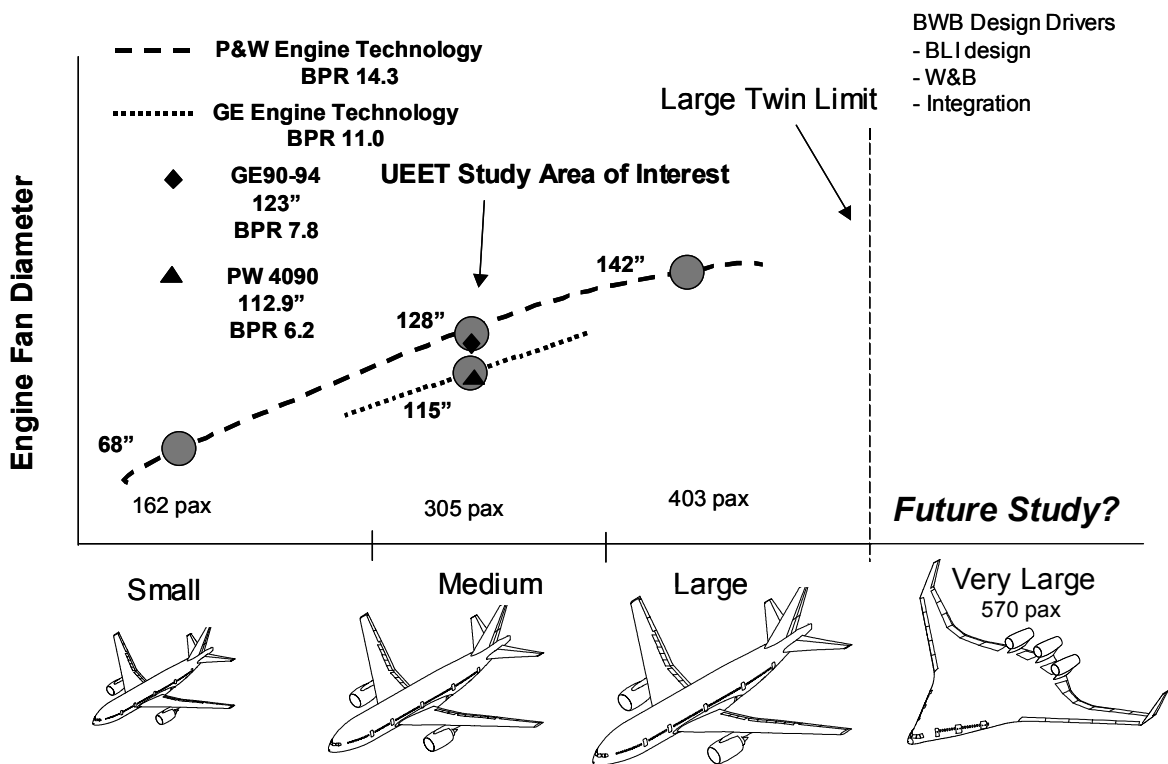

Figure 5.1. Engine diameter optimization summary

REFERENCES

1. Raymer, D.P., *Aircraft design, a conceptual approach*, AIAA educational series, 1999.
2. Daggett, D.L., et al., *Ultra-Efficient Engine Technology Systems Integration and Environmental Assessment*, NASA/CR—2002-211754, July 2002.
3. Svoboda, C., *Turbofan engine database as a preliminary design tool*, University of Kansas, Lawrence, KS, USA, Aircraft Design v3 n1 2000 pp. 17–31.
4. Ingraldi, A.M., Kariya, T.T., Re, R.J., Pendergraft, O.C., Jr., *Interference effects of very high bypass ratio nacelle installations on a low-wing transport*, Journal of Engines for Gas Turbines and Power Trans ASME v114 n4 Oct 1992 pp. 809–815.
5. DAR Aircraft Computer Design Program, *Advanced Aircraft Analysis*, DAR corporation, Lawrence KA., 2001.
6. Roskam, J., *Airplane Design*_(Parts I, and II) Roskam Aviation and Engineering Corp. Ottawa, KS.
7. Tillman, G., et al., *Updated Systems-Level Benefits Analysis of a Variable Area Fan Nozzle Propulsion System*, NASA R01–6.100.0010–4.
8. Owens, R.E., et al., *Ultra High Bypass Turbofan Technologies for the Twenty-First Century*. AIAA paper 90–2397, presented at the AIAA/SME/ASME/ASEE 26th Joint Propulsion Conference, Orlando, FL, July 1990.
9. McCall, J.E., Tracksdorf, P., Heinig, K., *Advanced ducted engine nacelle aerodynamics and integration testing*. Journal Eng Gas Turbines Power Transaction, ASME v114 n4 Oct 1992 pp. 802–808.
10. ESDU International Publication, *Drag of axisymmetric cowls at zero incidence for subsonic Mach numbers*, ESDU Data Item 81024.
11. Kirby, Dr. Michelle R., *Technology Metrics Assessment & Tracking (TMAT) Process for NASA's UEET Program*, Aerospace Systems Design Laboratory Georgia Institute of Technology, UEET 2002 Technology Forum.
12. United Technologies (Proprietary) report R01–6.100.0010–4, *"Updated Systems-Level Benefits Analysis of a Variable Area Fan Nozzle Propulsion System,"* July 2001.
13. International Civil Aviation Organization (ICAO), *International Standards and Recommended Practices, Environmental Protection, Annex 16 to the Convention on International Civil Aviation, Volume II, Aircraft Engine Emissions*, 2nd Edition, Montreal 1993.

REPORT DOCUMENTATION PAGEForm Approved
OMB No. 0704-0188

Public reporting burden for this collection of information is estimated to average 1 hour per response, including the time for reviewing instructions, searching existing data sources, gathering and maintaining the data needed, and completing and reviewing the collection of information. Send comments regarding this burden estimate or any other aspect of this collection of information, including suggestions for reducing this burden, to Washington Headquarters Services, Directorate for Information Operations and Reports, 1215 Jefferson Davis Highway, Suite 1204, Arlington, VA 22202-4302, and to the Office of Management and Budget, Paperwork Reduction Project (0704-0188), Washington, DC 20503.

1. AGENCY USE ONLY (Leave blank)		2. REPORT DATE May 2003	3. REPORT TYPE AND DATES COVERED Final Contractor Report	
4. TITLE AND SUBTITLE Ultra-Efficient Engine Diameter Study			5. FUNDING NUMBERS WBS-22-714-08-02 NAS3-01140, Task 10	
6. AUTHOR(S) David L. Daggett, Stephen T. Brown, and Ron T. Kawai				
7. PERFORMING ORGANIZATION NAME(S) AND ADDRESS(ES) Boeing Commercial Airplane Group P.O. Box 3707 Seattle, Washington 98124-2207			8. PERFORMING ORGANIZATION REPORT NUMBER E-13893	
9. SPONSORING/MONITORING AGENCY NAME(S) AND ADDRESS(ES) National Aeronautics and Space Administration Washington, DC 20546-0001			10. SPONSORING/MONITORING AGENCY REPORT NUMBER NASA CR-2003-212309	
11. SUPPLEMENTARY NOTES Project Manager, Mary Jo Long-Davis, Aeronautics Directorate, NASA Glenn Research Center, organization code 2600, 216-433-8708.				
12a. DISTRIBUTION/AVAILABILITY STATEMENT Unclassified - Unlimited Subject Categories: 01 and 07 Available electronically at http://gltrs.grc.nasa.gov This publication is available from the NASA Center for AeroSpace Information, 301-621-0390.			12b. DISTRIBUTION CODE	
13. ABSTRACT (Maximum 200 words) Engine fan diameter and Bypass Ratio (BPR) optimization studies have been conducted since the beginning of the turbofan age with the recognition that reducing the engine core jet velocity and increasing fan mass flow rate generally increases propulsive efficiency. However, performance tradeoffs limit the amount of fan flow achievable without reducing airplane efficiency. This study identifies the optimum engine fan diameter and BPR, given the advanced Ultra-Efficient Engine Technology (UEET) powerplant efficiencies, for use on an advanced subsonic airframe. Engine diameter studies have historically focused on specific engine size options, and were limited by existing technology and transportation infrastructure (e.g., ability to fit bare engines through aircraft doors and into cargo holds). This study is unique in defining the optimum fan diameter and drivers for future 2015 (UEET) powerplants while not limiting engine fan diameter by external constraints. This report follows on to a study identifying the system integration issues of UEET engines. This Engine Diameter study was managed by Boeing Phantom Works, Seattle, Washington through the NASA Glenn Revolutionary Aero Space Engine Research (RASER) contract under task order 10. Boeing Phantom Works, Huntington Beach, completed the engine/airplane sizing optimization, while the Boeing Commercial Airplane group (BCA) provided design oversight. A separate subcontract to support the overall project was issued to Tuskegee University.				
14. SUBJECT TERMS High bypass ratio; Geared turbofans; Optimum fan diameter; Ultra-Efficient Engine Technology program			15. NUMBER OF PAGES 63	
			16. PRICE CODE	
17. SECURITY CLASSIFICATION OF REPORT Unclassified	18. SECURITY CLASSIFICATION OF THIS PAGE Unclassified	19. SECURITY CLASSIFICATION OF ABSTRACT Unclassified	20. LIMITATION OF ABSTRACT	