



Ultra High Power and Efficiency Space Traveling-Wave Tube Amplifier Power Combiner With Reduced Size and Mass for NASA Missions

*Rainee N. Simons, Edwin G. Wintucky, Jeffrey D. Wilson, and Dale A. Force
Glenn Research Center, Cleveland, Ohio*

NASA STI Program . . . in Profile

Since its founding, NASA has been dedicated to the advancement of aeronautics and space science. The NASA Scientific and Technical Information (STI) program plays a key part in helping NASA maintain this important role.

The NASA STI Program operates under the auspices of the Agency Chief Information Officer. It collects, organizes, provides for archiving, and disseminates NASA's STI. The NASA STI program provides access to the NASA Aeronautics and Space Database and its public interface, the NASA Technical Reports Server, thus providing one of the largest collections of aeronautical and space science STI in the world. Results are published in both non-NASA channels and by NASA in the NASA STI Report Series, which includes the following report types:

- **TECHNICAL PUBLICATION.** Reports of completed research or a major significant phase of research that present the results of NASA programs and include extensive data or theoretical analysis. Includes compilations of significant scientific and technical data and information deemed to be of continuing reference value. NASA counterpart of peer-reviewed formal professional papers but has less stringent limitations on manuscript length and extent of graphic presentations.
- **TECHNICAL MEMORANDUM.** Scientific and technical findings that are preliminary or of specialized interest, e.g., quick release reports, working papers, and bibliographies that contain minimal annotation. Does not contain extensive analysis.
- **CONTRACTOR REPORT.** Scientific and technical findings by NASA-sponsored contractors and grantees.
- **CONFERENCE PUBLICATION.** Collected

papers from scientific and technical conferences, symposia, seminars, or other meetings sponsored or cosponsored by NASA.

- **SPECIAL PUBLICATION.** Scientific, technical, or historical information from NASA programs, projects, and missions, often concerned with subjects having substantial public interest.
- **TECHNICAL TRANSLATION.** English-language translations of foreign scientific and technical material pertinent to NASA's mission.

Specialized services also include creating custom thesauri, building customized databases, organizing and publishing research results.

For more information about the NASA STI program, see the following:

- Access the NASA STI program home page at <http://www.sti.nasa.gov>
- E-mail your question via the Internet to help@sti.nasa.gov
- Fax your question to the NASA STI Help Desk at 301-621-0134
- Telephone the NASA STI Help Desk at 301-621-0390
- Write to:
NASA Center for AeroSpace Information (CASI)
7115 Standard Drive
Hanover, MD 21076-1320

NASA/TM—2009-215584



Ultra High Power and Efficiency Space Traveling-Wave Tube Amplifier Power Combiner With Reduced Size and Mass for NASA Missions

*Rainee N. Simons, Edwin G. Wintucky, Jeffrey D. Wilson, and Dale A. Force
Glenn Research Center, Cleveland, Ohio*

National Aeronautics and
Space Administration

Glenn Research Center
Cleveland, Ohio 44135

March 2009

Acknowledgments

The authors would like to thank Todd T. Peterson, NASA GRC Program Manager for supporting the Lunar Reconnaissance Orbiter (LRO) Traveling-Wave Tube Amplifier (TWTA) development. In addition, the authors greatly appreciate the support that they have received from Neal R. Robbins, Daniel R. Dibb, Dr. William L. Menninger, Dr. Xiaoling Zhai, Robert Benson, James Burdette, David E. Lewis, and Paul C. Spitsen at L-3 Communications, Electron Technologies Inc.

This report contains preliminary findings,
subject to revision as analysis proceeds.

Level of Review: This material has been technically reviewed by technical management.

Available from

NASA Center for Aerospace Information
7115 Standard Drive
Hanover, MD 21076-1320

National Technical Information Service
5285 Port Royal Road
Springfield, VA 22161

Available electronically at <http://gltrs.grc.nasa.gov>

Ultra High Power and Efficiency Space Traveling-Wave Tube Amplifier Power Combiner With Reduced Size and Mass for NASA Missions

Rainee N. Simons, Edwin G. Wintucky, Jeffrey D. Wilson, and Dale A. Force
National Aeronautics and Space Administration
Glenn Research Center
Cleveland, Ohio 44135

Abstract

In the 2008 International Microwave Symposium (IMS) Digest version of our paper, recent advances in high power and efficiency space traveling-wave tube amplifiers (TWTAs) for NASA's space-to-Earth communications are presented. The RF power and efficiency of a new K-Band amplifier are 40 W and 50 percent and that of a new Ka-Band amplifier are 200 W and 60 percent. An important figure-of-merit, which is defined as the ratio of the RF power output to the mass (W/kg) of a TWT, has improved by a factor of ten over the previous generation Ka-Band devices. In this extended paper, a high power, high efficiency Ka-band combiner for multiple TWTs, based on a novel hybrid magic-T waveguide circuit design, is presented. The measured combiner efficiency is as high as 90 percent. In addition, at the design frequency of 32.05 GHz, error-free uncoded BPSK/QPSK data transmission at 8 megabits per second (Mbps), which is typical for deep space communications is demonstrated. Furthermore, QPSK data transmission at 622 Mbps is demonstrated with a low bit error rate of 2.4×10^{-8} , which exceeds the deep space state-of-the-art data rate transmission capability by more than two orders of magnitude. A potential application of the TWT combiner is in deep space communication systems for planetary exploration requiring transmitter power on the order of a kilowatt or higher.

I. Introduction

Communications signals transmitted from spacecrafts orbiting the outer planets or from the vicinity of the lunar surface need to travel enormous distances to ground antennas. In addition, as the distance from the Sun increases, the amount of solar energy that is available for conversion to electrical power on board the spacecraft decreases. Hence, there is a need for developing reliable space amplifiers, which are capable of delivering ultra high RF power as well as operating with very high efficiency (Ref. 1). In addition, these amplifiers need to be lightweight and small in size. The two possible solutions to this problem are based on either solid-state or microwave vacuum electronics technology. Solid-state devices based on GaAs or GaN high electron mobility transistor (HEMT) technology, when characterized on-wafer using load-pull techniques, deliver only about 2 to 3 W of RF power at Ka-Band frequencies (Ref. 2). Although these devices have efficiencies as high as 35 to 40 percent, the overall efficiency

of Ka-Band high power solid-state power amplifiers (SSPAs) are on the order of 15 to 20 percent, as described in the 2008 International Microwave Symposium (IMS) Digest version of our paper (Ref. 3). The low efficiency results in thermal management issues, which impacts reliability. On the other hand, microwave vacuum electronics based devices for space applications such as helix traveling wave tubes (TWTs) have demonstrated reliability at higher microwave frequencies with power output in the range of ten to several hundred watts and corresponding efficiency in the range of 40 to 60 percent (Refs. 4 and 5).

Deep space missions in the past have typically relied either on solar cells or radioactive thermal generators as a source of electrical power, which greatly limits the power available for communications. As an alternative, NASA has been developing nuclear fission electric power and propulsion technologies, which would provide orders of magnitude more power for science instruments onboard the spacecraft. An example was the Prometheus project (Ref. 6). This would potentially make possible the support of high power communications systems with data transmission rates 1000X higher (8 to 10 Mbps) than that previously achieved (10 kilobits per second (kbps)) from deep space. To enable such high data rates, several approaches to develop an onboard RF transmitter with an output power on the order of about 1 kW at Ka-Band, including power combining, are being considered.

Communication from the vicinity of the Moon is considered to be near-Earth while that from the planets of our solar system is considered to be from deep space. The corresponding downlink frequency band designated for near-Earth is 25.5 to 26.5 GHz (K-Band) and for deep space communications is 31.8 to 32.3 GHz (Ka-Band). In the 2008 IMS Digest version of our paper (Ref. 3), we presented the microwave performance of a new K-Band helix TWT for near-Earth communications and also a new Ka-Band helix TWT for deep space communications. Both of these units were manufactured by L-3 Communications, Electron Technologies Inc. (ETI) under contracts from NASA Glenn Research Center (GRC).

In this extended paper, we present the development of a novel Ka-Band power combiner architecture based on the use of hybrid magic-T's for combining the power output from multiple TWTs in a binary configuration with the potential to achieve 1 kW (Ref. 7). This architecture avoids the need to develop a single ultra-high power TWT, which would be technically challenging. To the best of our knowledge this

work demonstrates the highest power combining achieved with a Ka-Band magic-T. The TWTs utilized in the combiner experiment were also manufactured by L-3 Communications ETI under a contract from NASA GRC. Our approach has the following unique features: first, the size and mass are small, which are desired features for space applications. Second, it has low insertion loss and excellent output amplitude/phase balance, which ensures high combining efficiency. Third, it has very high isolation between the two input ports, which allows a TWT to continue operating if the other fails. Fourth, the circuit is capable of operating over nearly 60 percent of the waveguide band and hence has wide bandwidth if needed for high data rates. Fifth, the ports are impedance matched and hence minimize reflection introduced inter-symbol interference, which degrades bit error rate (BER). Sixth, the experiments reported in this paper have been carried out over the NASA's Deep Space Network (DSN) downlink Ka-Band frequency range of 31.8 to 32.3 GHz.

II. TWT Design and Modeling

Until recently, the design of TWTs was mainly done through trial and error, which was time consuming and expensive. The advances made in desktop computing and electromagnetic simulation/optimization tools have enabled the first pass design success of modern TWTs. These include the U.S. Naval Research Laboratory's CHRISTINE 3-D Code for high efficiency slow-wave interaction circuit and MICHELLE 3-D Code for multi-stage depressed collector design (Refs. 8 to 10). In addition, efficient thermal modeling/simulation tools are also available, which have enhanced the power handling capability of TWTs by integrating efficient conduction cooled packages. Furthermore, advances in materials technology have resulted in lightweight, temperature stable, high B-H (magnetic flux-magnetic field) product samarium cobalt permanent magnets, which are used in focusing the electron beam. Moreover, advances in tungsten/osmium cathode technology have resulted in cathode lifetimes exceeding 20 years in space (Ref. 11).

III. K-Band and Ka-Band Space TWT Requirements and Measured Performance

A. L-3 ETI Model 9835H K-Band TWT

The K-Band TWT was developed for communications from the Lunar Reconnaissance Orbiter (LRO) spacecraft to Earth. This spacecraft is scheduled for launch in April 2009. The specifications for this TWT are presented in (Ref. 3). Three TWTs were manufactured and characterized and all three meet full specification, resulting in first pass design success and 100 percent yield. The measured output power, overall

efficiency, and saturated gain of the three TWTs are presented in (Ref. 3).

B. L-3 ETI Model 999H Ka-Band TWT

This Ka-Band TWT was developed for communications from a spacecraft orbiting Mars to NASA's DSN ground stations. The power output and overall efficiency of the TWT are 100 W and 60 percent, respectively. This TWT also served as an engineering model to validate the advanced design codes described earlier in Section II and paved the way for the successful development of the space qualified 200-W TWT described next.

C. L-3 ETI Model 999HA Ka-Band TWT

This Ka-Band TWT was developed for communications from a spacecraft orbiting any of the outer planets, such as Jupiter or its icy Moons. The specifications for the model 999HA Ka-Band TWT are presented in (Ref. 3). Three such TWTs were manufactured and characterized and all were able to demonstrate at least 180 W. The TWT S/N 202 was tested up to 250 W and for long service life space qualified at 200 W. The measured overall efficiency and saturated gain of this TWT exceeded 60 percent and 55 dB, respectively. The measured characteristics are presented in (Ref. 3).

To transmit data from Jupiter at very high rates on the order of several megabits per second, the spacecraft transmitter power needs to be on the order of 1 kW. To achieve this kind of power level, the outputs from four of the above TWTs would be combined. Combining efficiency as high as 90 percent has been demonstrated at Ka-Band frequencies for a two-way combiner.

Both the K-Band and Ka-Band TWTs have four-stage depressed collector circuits for high efficiency. The collector circuits require high voltages, which are provided by a separate electronic power conditioner (EPC) attached by an umbilical power cord to the TWT.

IV. Electronic Power Conditioners (EPCs) for TWTs

The model 2300HE 7-kV electronic power conditioner (EPC) is mated with the 40-W K-Band TWT and the model 1693HC 14-kV EPC is mated with the 180-W Ka-Band TWT to form two new TWT amplifiers. These EPCs are also manufactured by L-3 Communications ETI. These EPCs are highly reliable and efficient (90 percent) and can operate from either regulated or unregulated spacecraft bus voltages. A single EPC can be used to independently operate two TWTs. The masses and dimensions of the TWT and the EPC are presented in (Ref. 3).

V. High Power Combiner Operating Principle

A two-way high power combiner based on a waveguide magic-T hybrid coupler is shown in Figure 1(a). In this approach, the two TWTAs are coupled to Ports #1 and #4 (H-Plane and the E-Plane ports along the plane of symmetry) of the magic-T, respectively. The incident power at Port #1 (from TWT #1) is evenly split into two in-phase components between Ports #2 and #3. The power incident at Port #4 (from TWT #2) is also evenly split but with 180° phase difference between Ports #2 and #3. The magic-T is designed such that the electrical lengths between any port and the junction are identical. Thus by the superposition principle, the power at Port #2 must add in phase while an equal power at Port #3 must result in perfect cancellation. Consequently, Ports #2 and #3 are referred to as the sum and difference ports, respectively. This two-way combiner architecture can be extended in a binary configuration to obtain 1 kW by combining 2^n TWTAs, where n is an integer, as illustrated in Figure 1(b).

VI. High Power Hybrid Magic-T

The high power hybrid magic-T used in our demonstration was manufactured by Millitech, Inc. and is shown in Figure 2. The two input ports and the sum and difference ports are indicated. The magic-T is fabricated from aluminum and has a split block construction for ease of fabrication. In addition steel guide pins are provided at all ports for precision alignment. The measured worst-case insertion loss and VSWR are about 0.45 dB and 1.47, respectively, and they occur at the high frequency end of the band. In addition, the measured amplitude and phase balance are within 0.27 dB and $\pm 6^\circ$, respectively. Using equations from (Ref. 12), the calculated additional losses in combining efficiency due to the above amplitude and phase deviations are about 3.0 and 1.1 percent, respectively.

Lastly, measurements show that Ports #1 and #4 of the magic-T have very high isolation on the order of 30 dB or higher across the band of interest. Therefore, the magic-T was chosen over a hybrid 90° coupler, which has an isolation of about 20 dB. The mass and size of the magic-T are about 100 gm and $50 \times 50 \times 50$ mm, respectively.

VII. Power Combiner Measured Performance

The power combiner was successfully demonstrated with a pair of 100-W (L-3 ETI Model 999H, Serial Number 101 and 102) high efficiency Ka-Band space TWTs. Figures 3(a), (b), and (c) show the measured power output from the two TWTs and the magic-T combiner as a function of the input power to the TWT at the lower edge (31.8 GHz), center (32.05 GHz) and upper edge (32.3 GHz) of the NASA DSN 500 MHz wide

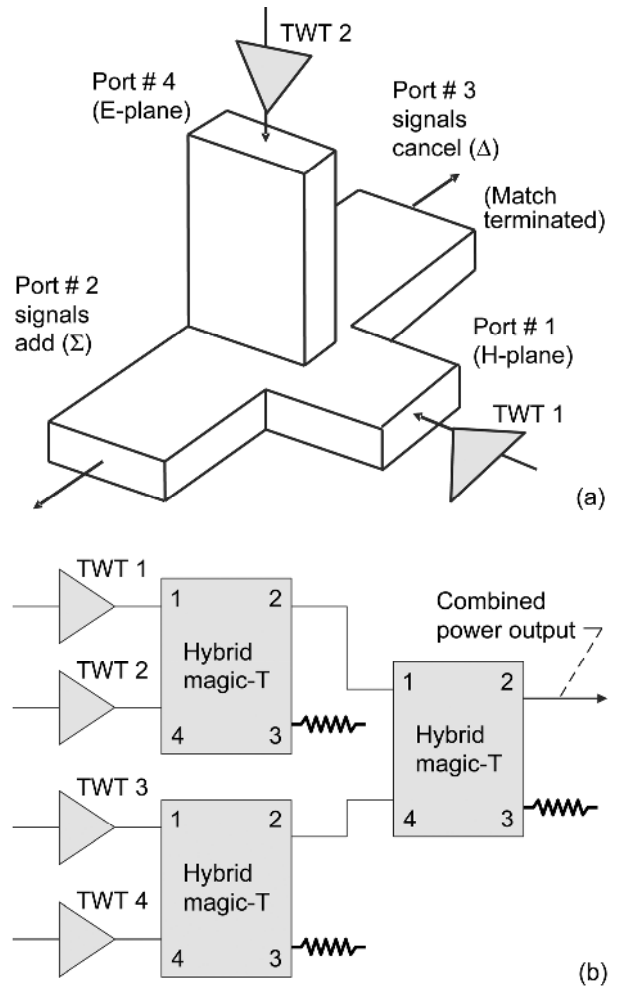

Figure 1.—(a) Basic configuration of waveguide magic-T based power combiner for two coherent TWTs. (b) Binary circuit architecture for combining 2^n TWTs, where n is an integer (shown here for $n = 2$).

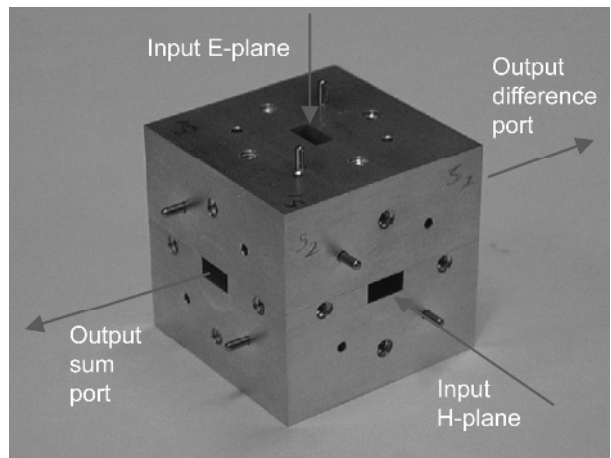

Figure 2.—Waveguide (WR-28) hybrid magic-T used in high power combiner circuit showing sum and difference output ports.

frequency band. It can be seen that the two TWTs are well balanced with the combined output power at about 3 dB (2X) greater. The AM-to-PM values for the two TWTs are less than

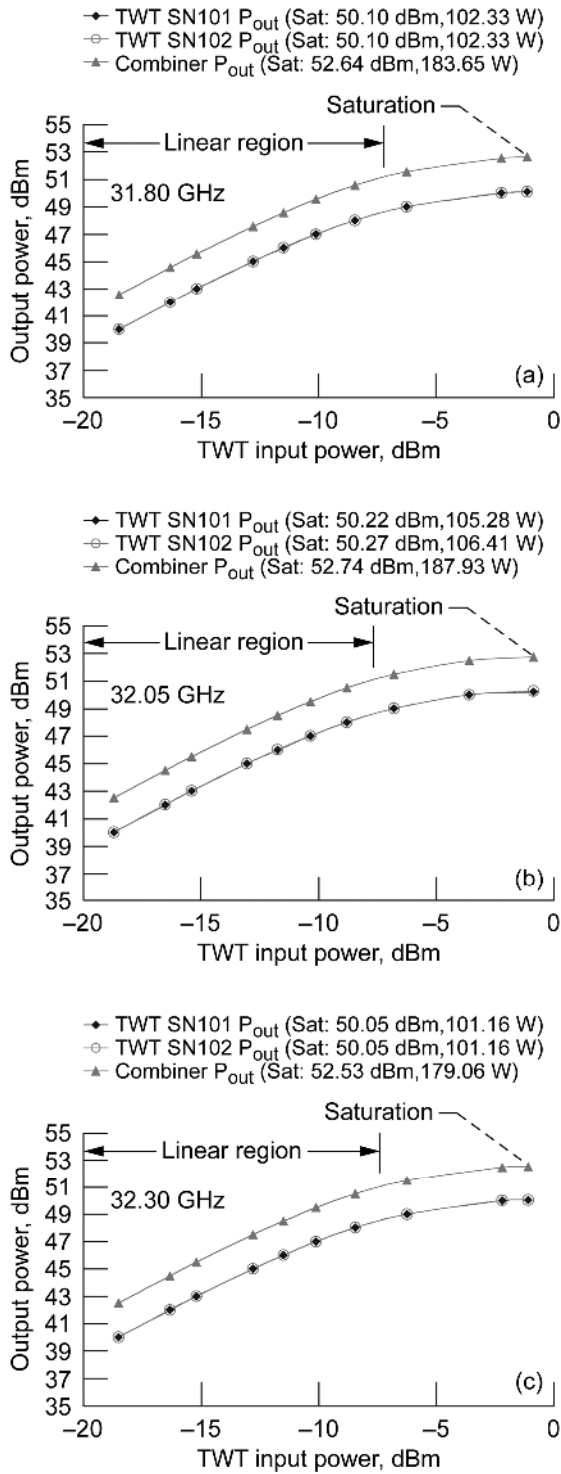

Figure 3.—Measured power output from individual TWTs (Model 999H) and magic-T combiner as function of input power to TWT. (a) 31.8 GHz. (b) 32.05 GHz. (c) 32.30 GHz.

3.5 deg/dB at saturation. The phase changes at the output of the two TWTs when the input RF drive is increased from small signal (-20 dBm) to saturation (0 dBm) are 44° and 32°, respectively.

For these measurements, a microwave signal generator and a 3 dB power divider were used as the RF source to the two TWTs. In addition, one of the input arms to the TWTs included a variable attenuator and a variable phase shifter. The magic-T input powers were balanced with the variable attenuator. The magic-T input phases were balanced by adjusting the phase shifter for a minimum power reading at the difference port, which corresponds to a maximum combined power at the sum port. Consequently, the phase changes, AM-to-AM, and AM-to-PM characteristic differences of the TWTs did not impact the output power.

Figure 4 shows the power combining efficiencies at the center (32.05 GHz) and ±250 MHz band edge frequencies. The combining efficiencies were about 88.5 percent or greater. As shown in Figure 4, the power combining efficiency is maintained over a broad range of input powers. The importance of this is that the power combiner is equally efficient at both the lower output power linear region, where multi-channel commercial satellite transmitter TWTs usually operate, and the non-linear saturation region, where deep space communications systems typically operate for maximum TWT power and efficiency. In Figure 4 at a fixed frequency, the difference in efficiency as a function of the total input power to the combiner is within ±0.5 percent.

Improvements in performance are possible by optimizing the magic-T for efficiency and higher power handling capability over a narrow frequency range of specific interest. This was demonstrated with computer modeling of the magic-T and alternative hybrid junctions using Microwave Studio (Ref. 13). The folded E-plane magic-T appears to be the most promising of all the types that were investigated. A custom optimized magic-T with about 500 MHz bandwidth and improved waveguide surface properties is estimated to have an insertion loss on the order of 0.25 dB (Ref. 13).

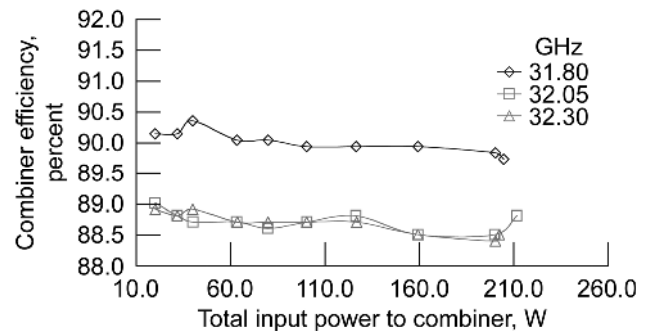

Figure 4.—Measured efficiency of magic-T based power combiner as function of total input power.

VIII. Combiner Reliability

In the event of a single TWT failure, the combined power output would decrease by 6 dB. However, with appropriate placement of two waveguide switches as shown in Figure 5(a), the power loss would be only 3 dB. In this arrangement under normal operation, the waveguide switches allow the TWT outputs to be combined in the magic-T. If either one of the TWTs fail then the other TWT is directly connected to the RF output. The sensor connected to Port #3 detects the power imbalance and commands the switches to reroute the TWT output. In addition, a ferrite circulator present between the RF output port and the antenna prevents the reflections from the antenna from influencing the imbalance sensor control.

With the addition of a back-up TWT and appropriate placement of two waveguide switches as shown in

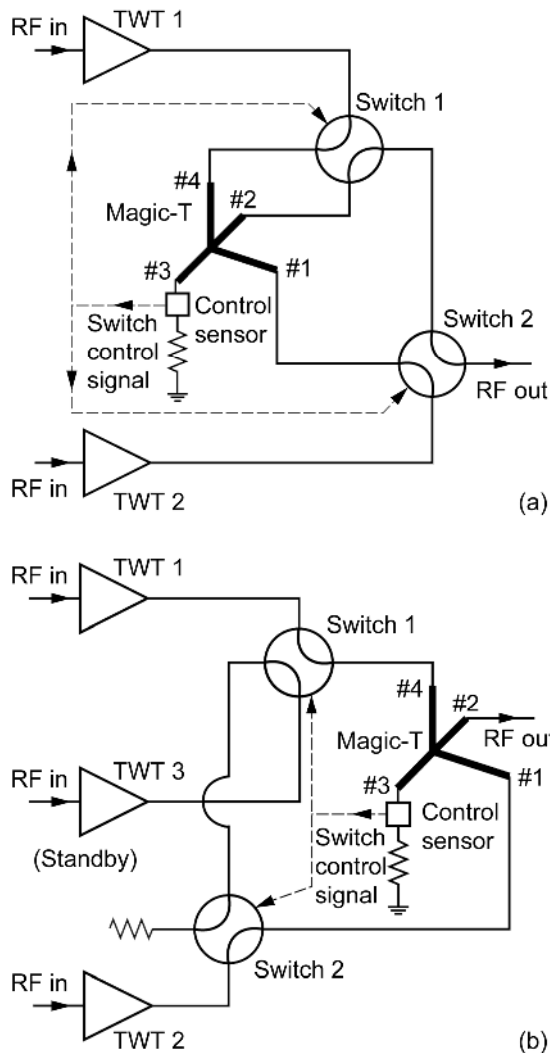

Figure 5.—Combiner with redundancy. (a) Includes two waveguide switches. (b) Includes two waveguide switches and standby TWT. Ports #1 through #4 correspond to ports of magic-T in Figure 1(a).

Figure 5(b), the power loss would be zero. In this scheme under normal operation, TWT #1 and #2 are combined. In the event of a TWT failure, the standby TWT #3 can be switched in place of the failed TWT without loss in system performance. The circuits in Figures 5(a) and (b) are work in progress requiring additional efforts for performance optimization and the design details are not available yet.

IX. Bit Error Rate (BER) Characterization

To demonstrate the TWT and combiner performance, we employed un-coded BPSK and QPSK bit streams. However, in an actual space-to-Earth link both block coding as well as convolution coding would be used for error correction. In addition, QPSK allows the TWTA to operate in saturation and consequently at the highest possible efficiency, which is a desired attribute in situations where prime power is scarce. Bit error rate (BER) tests were performed at the output of the magic-T combiner when the data rate was on the order of 8 and 622 Mbps.

At 8 Mbps, error-free ($BER < 1 \times 10^{-9}$) un-coded BPSK and QPSK data transmission was observed. This was possible because the bandwidth occupied by the BPSK and QPSK signals were 8 and 4 MHz, respectively. Over these narrow bands, the rate of change in phase with frequency along the two TWT paths was small. The energy per bit/noise power spectral density ratio (E_b/N_0) was 21 dB at a BER of 10^{-9} for a QPSK data rate of 8 Mbps. Since there was no equalizer in the receiver, the BER was due primarily to inter-symbol interference. The 8 Mbps is in the range of data rates proposed for some of the planetary exploration missions.

Future deep space missions are calling for data rates approaching a gigabit per second at Ka-Band. The bandwidth allocated at Ka-Band is 500 MHz (31.8 to 32.3 GHz). A high data rate QPSK signal would occupy a significant portion of this bandwidth. However, in the characterization of our TWT combiner we were limited by our test equipment, which could deliver only 622 Mbps of QPSK data and required a bandwidth of 311 MHz. Initially, over this band, the rate of change in phase with frequency along the two TWT paths was large. This created a significant phase imbalance at the inputs to the magic-T combiner. The phase imbalance resulted in an observed reduction in signal amplitude of about 15 dB at the band edges. The above phase and amplitude changes made it impossible to detect the transmitted signal. By adding an appropriate dispersive component on one of the TWT paths, the disparity in electrical lengths and effect on RF amplitude was eliminated. The phase compensation was made by adding a section of a standard WR-28 waveguide at the input of one of the TWTs. With the waveguide in place, the measured rate of change of phase difference with frequency at the input ports to the magic-T was 0.147 deg/MHz compared to 0.991 deg/MHz before compensation and is presented in Figure 6. The 0.147 deg/MHz rate of change of phase with

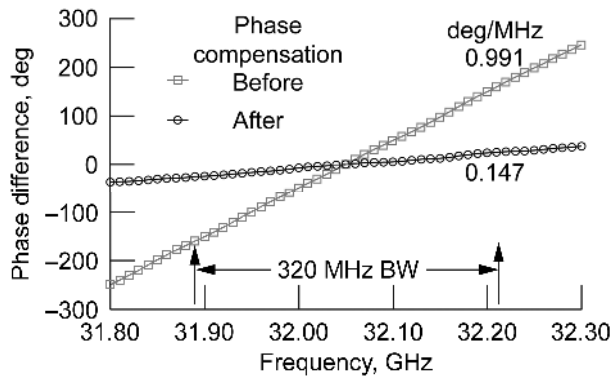

Figure 6.—Measured rate of change of phase difference at input ports to magic-T as function of frequency before and after phase compensation. For both cases, phase difference is set equal to 0° at center frequency of 32.05 GHz.

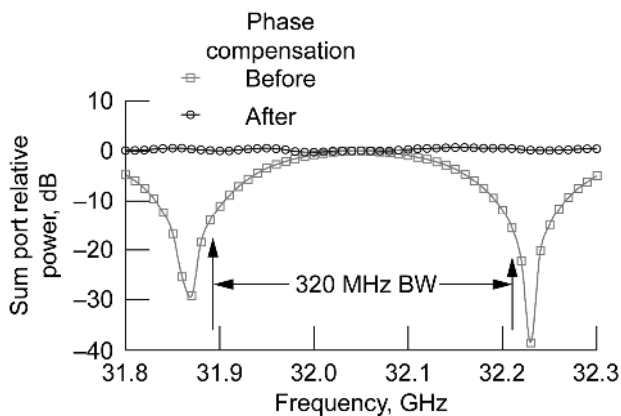

Figure 7.—Measured combined saturated relative power at sum port of magic-T as function of frequency before and after phase compensation. For both cases, relative power is set equal to 0 dB at 32.05 GHz.

frequency was observed out to at least 3 GHz (30.55 to 33.55 GHz).

Although further improvement is possible, this was adequate for a 622 Mbps data transmission rate QPSK signal with low BER, which required only 311 MHz of the available bandwidth. Figure 7 shows the measured combined saturated relative power at the sum port of the magic-T as a function of the frequency before and after compensation. As a result of this circuit modification, we were able to successfully demonstrate QPSK data transmission at 622 Mbps with a low BER of 2.4×10^{-8} , which exceeds the data rate required for a typical deep space mission by more than two orders of magnitude.

X. Conclusions and Discussions

The performance parameters of a K-Band and a Ka-Band TWT for NASA's near-Earth and deep space communications are presented in the 2008 IMS Digest version of our paper

(Ref. 3). These results are state-of-the art and provide unprecedented performance. The model 999HA Ka-Band 200-W TWT became available for the very first time in 2006. Prior to this development, the highest CW RF power produced by a U.S. manufactured space TWT at Ka-Band and flown in space is the model 910H TWT. This TWT was manufactured by L-3 ETI, for the Cassini-Huygens Mission with 10 W, 41 percent overall efficiency and a mass of 0.75 kg (Ref. 14). The Ka-Band model 999HA TWT increases the output power by a factor of twenty to 200 W while only doubling the mass to 1.5 kg. Thus a figure-of-merit (FOM) defined as the ratio of the RF power output to the mass (W/kg) shows an increase of a factor of ten.

In this extended paper, a compact Ka-Band high power high efficiency combiner based on a hybrid magic-T for combining the output from multiple TWTAs has been successfully demonstrated over NASA's DSN frequency band. At the design frequency of 32.05 GHz, error-free uncoded BPSK/QPSK data transmission at 8 Mbps and QPSK data transmission at 622 Mbps with a low BER of 2.4×10^{-8} was demonstrated. The 622 Mbps data rate is significantly higher than the state-of-the-art, for example 5.247 Mbps for the Mars Reconnaissance Orbiter (MRO) mission (Ref. 15). The measurements show that two 100-W TWTs can be combined with efficiency as high as 90 percent. Based on these measurements, the projected combiner efficiency of an eight-way combiner for eight 100-W model 999H TWTs to achieve about 800 W would be about 73 percent. On the other hand, if four 200-W model 999HA TWTs are used, then the projected combiner efficiency would be about 81 percent. The total mass of the combiner consisting of four 200-W TWTs (Ref. 3), two EPCs (Ref. 3), and a magic-T is about 15 kg and the total volume is equal to that of a cube with sides less than 28 cm.

References

1. J.H. Booske, D.R. Whaley, W.L. Menninger, R.S. Hollister, and C.M. Armstrong, "Traveling-wave tubes," in *Modern Microwave and Millimeter-Wave Power Electronics*, R.J. Barker *et al.*, Ed. New York: Wiley-Interscience, Ch. 4, pp. 171–245, 2005.
2. J.C. Freeman, E.G. Wintucky, and C.T. Chevalier, "High Power High Efficiency Ka-band Power Combiners for Solid-State Devices," NASA Technical Memorandum, NASA/TM—2006-214447, Nov. 2006. (Available electronically at <http://gltrs.grc.nasa.gov>)
3. R.N. Simons, J.D. Wilson, and D.A. Force, "High Power and Efficiency Space Traveling-Wave Tube Amplifiers With Reduced Size and Mass for NASA Missions," 2008 IEEE MTT-S International Microwave Symposium Digest, pp. 319–322, Atlanta, GA, June 15–20, 2008.
4. J.M. Weekley and B.J. Mangus, "TWTA versus SSPA: A comparison of on-orbit reliability data," *IEEE Trans. Electron Devices*, Vol. 52, No. 5, pp. 650–652, May 2005.

5. E.F. Nicol, B.J. Mangus, and M.K. de Pano, "TWTA versus SSPA: A new look at Boeing fleet on-orbit reliability data and comparison factors," 2006 IEEE International Vacuum Electronics Conference, pp. 61–62, Monterey, CA, April 25–27, 2006.
6. R. Taylor, "Prometheus Project Final Report," JPL Document 982–R120461, Oct. 1, 2005. (Available electronically at <http://www.everyspec.com/NASA/NASA+-+JPL/index.php>)
7. E.G. Wintucky, R.N. Simons, K.R. Vaden, G. Lesny, and J.L. Glass, "High power combining of Ka-Band TWTs for deep space communications," 2006 IEEE International Vacuum Electronics Conference, pp. 63–64, Monterey, CA, April 25–27, 2006.
8. D. Chernin, T.M. Antonsen, Jr., B. Levush, and D.R. Whaley, "A three-dimensional multifrequency large signal model for helix traveling wave tubes," *IEEE Trans. Electron Devices*, Vol. 48, No. 1, pp. 3–11, Jan. 2001.
9. D.K. Abe, B. Levush, T.M. Antonsen, Jr., D.R. Whaley, and B.G. Danly, "Design of a linear C-band helix TWT for digital communications experiments using the CHRISTINE suite of large signal codes," *IEEE Trans. Plasma Science*, Vol. 30, No. 3, Part 1, pp. 1053–1062, June 2002.
10. J.J. Petillo, E.M. Nelson, J.F. DeFord, N.J. Dionne, and B. Levush, "Recent developments to the MICHELLE 2-D/3-D electron gun and collector modeling code," *IEEE Trans. Electron Devices*, Vol. 52, No. 5, pp. 742–748, May 2005.
11. J.D. Wilson, K.R. Vaden, E.G. Wintucky, D.A. Force, I.L. Krainsky, R.N. Simons, N.R. Robbins, W.L. Menninger, D.R. Dibb, and D.E. Lewis, "Advances in space traveling-wave tubes for NASA missions," *Proc. IEEE, Special Issue on Technical Advances in Deep Space Communications & Tracking: Part 1*, Vol. 95, No. 10, pp. 1958–1967, Oct. 2007.
12. S.E. Kubasek, D.M. Goebel, W.L. Menninger, and A.C. Schneider, "Power combining characteristics of backed-off traveling wave tubes for communications applications," *IEEE Trans. Electron Devices*, Vol. 50, No. 6, pp. 1537–1542, June 2003.
13. K.R. Vaden, "Computer aided design of Ka-Band waveguide power combining architectures for interplanetary spacecraft," NASA Technical Memorandum, NASA/TM—2006-214108, Feb. 2006. (Available electronically at <http://gltrs.grc.nasa.gov>)
14. A.N. Curren, J.A. Dayton, Jr., R.W. Palmer, K.J. Long, D.A. Force, C.E. Weeder, Z.A. Zachar, and W.L. Harvey, "The Cassini mission Ka-band TWT," IEEE International Electron Devices Meeting (IEDM) Technical Digest, pp. 783–786, San Francisco, CA, Dec. 11–14, 1994.
15. C.D. Edwards, Jr. and R. DePaula, "Key telecommunications technologies for increased data return for future Mars exploration," *Acta Astronautica*, Vol. 61, Issues 1–6, pp. 131–138, June-August 2007.

REPORT DOCUMENTATION PAGE

Form Approved
OMB No. 0704-0188

The public reporting burden for this collection of information is estimated to average 1 hour per response, including the time for reviewing instructions, searching existing data sources, gathering and maintaining the data needed, and completing and reviewing the collection of information. Send comments regarding this burden estimate or any other aspect of this collection of information, including suggestions for reducing this burden, to Department of Defense, Washington Headquarters Services, Directorate for Information Operations and Reports (0704-0188), 1215 Jefferson Davis Highway, Suite 1204, Arlington, VA 22202-4302. Respondents should be aware that notwithstanding any other provision of law, no person shall be subject to any penalty for failing to comply with a collection of information if it does not display a currently valid OMB control number.

PLEASE DO NOT RETURN YOUR FORM TO THE ABOVE ADDRESS.

1. REPORT DATE (DD-MM-YYYY) 01-03-2009		2. REPORT TYPE Technical Memorandum		3. DATES COVERED (From - To)	
4. TITLE AND SUBTITLE Ultra High Power and Efficiency Space Traveling-Wave Tube Amplifier Power Combiner With Reduced Size and Mass for NASA Missions				5a. CONTRACT NUMBER	
				5b. GRANT NUMBER	
				5c. PROGRAM ELEMENT NUMBER	
6. AUTHOR(S) Simons, Raine, N.; Wintucky, Edwin, G.; Wilson, Jeffrey, D.; Force, Dale, A.				5d. PROJECT NUMBER	
				5e. TASK NUMBER	
				5f. WORK UNIT NUMBER WBS 342556.06.01.10.01.02	
7. PERFORMING ORGANIZATION NAME(S) AND ADDRESS(ES) National Aeronautics and Space Administration John H. Glenn Research Center at Lewis Field Cleveland, Ohio 44135-3191				8. PERFORMING ORGANIZATION REPORT NUMBER E-16802-1	
9. SPONSORING/MONITORING AGENCY NAME(S) AND ADDRESS(ES) National Aeronautics and Space Administration Washington, DC 20546-0001				10. SPONSORING/MONITORS ACRONYM(S) NASA	
				11. SPONSORING/MONITORING REPORT NUMBER NASA/TM-2009-215584	
12. DISTRIBUTION/AVAILABILITY STATEMENT Unclassified-Unlimited Subject Category: 17 Available electronically at http://gltrs.grc.nasa.gov This publication is available from the NASA Center for AeroSpace Information, 301-621-0390					
13. SUPPLEMENTARY NOTES Submitted to IEEE Transactions on Microwave Theory and Techniques.					
14. ABSTRACT In the 2008 International Microwave Symposium (IMS) Digest version of our paper, recent advances in high power and efficiency space traveling-wave tube amplifiers (TWTAs) for NASA's space-to-Earth communications are presented. The RF power and efficiency of a new K-Band amplifier are 40 W and 50 percent and that of a new Ka-Band amplifier are 200 W and 60 percent. An important figure-of-merit, which is defined as the ratio of the RF power output to the mass (W/kg) of a TWT, has improved by a factor of ten over the previous generation Ka-Band devices. In this extended paper, a high power, high efficiency Ka-band combiner for multiple TWTs, based on a novel hybrid magic-T waveguide circuit design, is presented. The measured combiner efficiency is as high as 90 percent. In addition, at the design frequency of 32.05 GHz, error-free uncoded BPSK/QPSK data transmission at 8 megabits per second (Mbps), which is typical for deep space communications is demonstrated. Furthermore, QPSK data transmission at 622 Mbps is demonstrated with a low bit error rate of 2.4×10^{-8} , which exceeds the deep space state-of-the-art data rate transmission capability by more than two orders of magnitude. A potential application of the TWT combiner is in deep space communication systems for planetary exploration requiring transmitter power on the order of a kilowatt or higher.					
15. SUBJECT TERMS Telecommunications; Transmitters; Deep space network; Space communications; Satellite communication; Microwave transmission; Microwave amplifiers; Microwave tubes; Power amplifiers; Power conditioning; Power efficiency; Traveling wave tubes					
16. SECURITY CLASSIFICATION OF:			17. LIMITATION OF ABSTRACT	18. NUMBER OF PAGES	19a. NAME OF RESPONSIBLE PERSON
a. REPORT	b. ABSTRACT	c. THIS PAGE			STI Help Desk (email:help@sti.nasa.gov)
U	U	U	UU	13	19b. TELEPHONE NUMBER (include area code) 301-621-0390

