

NASA Contractor Report 3180

NASA
CR
3180
c.1

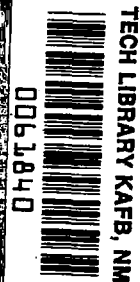

Ultrasonic Attenuation
and Velocity in AS/3501-6
Graphite/Epoxy Fiber Composite

James H. Williams, Jr., Hamid Nayeb-Hashemi,
and Samson S. Lee

GRANT NSG-3210
DECEMBER 1979

NASA



NASA Contractor Report 3180

Ultrasonic Attenuation and Velocity in AS/3501-6 Graphite/Epoxy Fiber Composite

James H. Williams, Jr., Hamid Nayeb-Hashemi,
and Samson S. Lee
*Massachusetts Institute of Technology
Cambridge, Massachusetts*

Prepared for
Lewis Research Center
under Grant NSG-3210



National Aeronautics
and Space Administration

**Scientific and Technical
Information Branch**

1979

INTRODUCTION

Several nondestructive evaluation (NDE) techniques and dynamic stress and strain analyses of fiber composites require some knowledge of their wave propagation characteristics [1]. Ultrasonic testing is an NDE technique in which a stress wave is introduced into a composite and the characteristics of the wave after it has propagated through the composite are related to some material property or flaw. Also, in analyzing acoustic emission (AE) signatures, knowledge of the wave transmission characteristics of the composite is very important in delineating the AE from various sources [2].

Vary et al. [3-5] have shown that ultrasonic attenuation can be correlated with the tensile strength and the interlaminar shear strength of graphite fiber composites. In testing graphite fiber polyimide composites, Hayford et al. [6] found good correlation between the initial attenuation and the shear strength. More recently, Williams and Doll [7] observed that the initial attenuation is an important indicator of fatigue life of unidirectional graphite fiber composites subjected to transverse compression-compression loading.

Two of the most important wave propagation parameters are the dispersion and attenuation. Dispersion is the dependence of phase velocity of harmonic waves upon frequency. Attenuation refers to the energy loss associated with the decrease in the stress wave amplitude due to scattering and absorption and is generally frequency-dependent.

The purpose of this paper is to present the experimental results of dispersion and attenuation studies on a unidirectional graphite fiber composite. Velocity and attenuation of both longitudinal and shear waves propagating in principal directions are considered. Also, the effects of transducer-specimen interface pressure and couplant are studied.

REVIEW OF EXPERIMENTAL INVESTIGATIONS

In studying wave propagation in composite laminates, Whitter and Peck [8] and Asay [9] found that laminated composites are dispersive. Touchert and Guzelsu [10] studied the dispersive behavior of boron epoxy composites for waves propagating parallel and perpendicular to the fiber direction. They reported that group velocities of longitudinal and transverse waves were essentially constant for wavelengths much larger than the fiber diameter and fiber spacing, but changed as the wavelength decreased to the same order of magnitude as the fiber spacing.

Waves are dispersed by two distinct mechanisms as they propagate through a fiber reinforced viscoelastic material. The first mechanism is viscoelastic dispersion due to the viscoelasticity of the medium. The second mechanism is geometric dispersion in which periodic waves are selectively transmitted and reflected due to some characteristic dimension of the composite. Sutherland [11] observed that the relatively fine structure of a cloth-laminated quartz phenolic was weakly dispersive below 4 MHz where viscoelastic dispersion dominated; whereas the relatively coarse structure of an Epon matrix embedded with steel wires was highly dispersive below 2 MHz which showed that geometric dispersion was the dominating mechanism. Also, it was concluded that test results would not be affected by moderate temperature changes within the 0° to 40°C range.

Dispersion and attenuation of various polymeric matrix materials (phenolic SC1008, polyester resin and PMMA) were obtained experimentally by Felix [12]. It was observed that the materials exhibited little dispersion but significant attenuation for dilatational waves in the frequency range 1 to 10 MHz. Thus, it was postulated that attenuation in the matrix might have a significant effect on the distortion of stress pulses in polymeric matrix composite materials.

MATERIALS, EQUIPMENT AND EXPERIMENTAL PROCEDURE

Materials

The materials are Hercules AS/3501-6 unidirectional graphite fiber epoxy composite and Hercules 3501-6 epoxy matrix. A schematic of the unidirectional composite is shown in Fig. 1. The Hercules Instructions [13] for fabricating the laminate were used except the precure temperature was maintained at 149°C instead of the specified 135°C. The epoxy specimens were cast in a vacuum oven and as specified by Hercules. (It is important to note that because of the differences in specified fabrication procedures of the cast epoxy and the laminate, the epoxy matrix in the fiber composites and the cast epoxy specimens may have different strength properties.)

The test specimens were cut from the panels in the form of rods with uniform square cross sections. The cross section was either 1.27 cm (0.50 in) square or 0.952 cm (0.375 in) square. The lengths of the specimens ranged from 0.38 cm (0.15 in) to 12.70 cm (5.00 in). Both the fiber composite and the epoxy matrix specimens were cut to the same dimensions.

Equipment

A schematic of the experimental system is shown in Fig. 2. The system consists of a pulse oscillator (Arenberg Model PG-652-C Mod II) for generating single frequency wave packet signals; two transducers of each type as listed in Table 2 (one each for

transmission and reception); an attenuator (Arenberg Model ATT-693); a low frequency inductance tuner (Arenberg Model LFT-500), a low frequency amplifier (Arenberg Model LFA-550), an oscilloscope (Tektronix Model 455); a transducer-specimen interface couplant (AET SC-6 for longitudinal waves and phenyle-salicylate for shear waves); a screw loading device that holds the specimen and the transducers; spring scales to monitor the transducer-specimen interface load; and a dial indicator to monitor the couplant thickness. Detailed descriptions of the individual components are given in Appendix C of [15].

Experimental Procedure

The measurement of attenuation and group velocity of ultrasonic waves in fiber composites may be affected by many parameters including the transducer-specimen interface pressure, the mechanical properties and thickness of the couplant, the alignment between the specimen and the transducer crystal, and the nonparallelism of the faces of the specimen. Special care was taken to ensure that the specimen was centered on the transducer face. Also, all opposite faces of the specimens were cut to within ± 0.0005 cm (± 0.0002 in) of parallelism.

In order to understand the relationship between the amplitude of the received signal and the transducer-specimen interface conditions, measurements relating the couplant thickness, the transducer-specimen interface pressure and the corresponding received signal amplitude were made. Two couplants were tested: AET SC-6 and a more viscous Automation Industry's Sperry 50A4084.

Because of the anisotropy of the composite, many modes of longitudinal and shear waves can be propagated for various directions of propagation and particle motion. The wave propagation modes which were investigated were along the principal orthotropic axes only and are summarized in Table 3.

A typical oscillator output signal is shown in the top trace in Fig. 3. This electrical signal was used to excite the transmitting transducer. This transducer introduced a stress wave into the specimen. After traversing the specimen, the stress wave was detected by the receiving transducer. The receiving transducer output was displayed on the oscilloscope as an electrical signal shown in the bottom trace in Fig. 3. The narrow band wave packets generated by the pulse oscillator were adjusted to have a repetition rate and duration that would produce nonoverlapping individual signals at the receiving transducer.

Attenuation measurements were made by comparing the relative amplitudes of the received signal through two different lengths of otherwise identical specimens. If the V_i are the voltage amplitudes of the received wave packets through specimens of respective lengths L_i , the attenuation $\alpha(\omega)$ which is a function of frequency ω (radian/sec) can be expressed as

$$\alpha(\omega) = \frac{\ln\left(\frac{V_2}{V_1}\right)}{L_1 - L_2} \quad (1)$$

where $\alpha(\omega)$ has the dimension of neper per centimeter, and \ln denotes the natural logarithm.

To evaluate the wave group velocity, the time shift between the same individual cycle of the input and output signals was measured. The few leading cycles were not used because of their transient nature. In order to cancel the inherent time delay due to the electrical system, otherwise identical specimens of different lengths were used. If the time shifts for specimens of lengths L_i are t_i , respectively, the group velocity $C_g(\omega)$ which is a function of frequency ω can be expressed as

$$C_g(\omega) = \frac{L_2 - L_1}{t_2 - t_1} \quad (2)$$

where $C_g(\omega)$ has the dimension of centimeter per second.

RESULTS AND DISCUSSION

Effect of Input Signal Amplitude

The linearity of the wave propagation phenomenon with respect to the input signal amplitude was investigated. The attenuations and group velocities were found to be independent of the amplitude of the input signal which over the range of approximately zero to 300 volts corresponded to a stress at the face of the transducer of approximately zero to 0.3 MN/m^2 (44 psi)* according to the manufacturer-supplied calibration curve. For the experimental measurements described below, the amplitude of the input signal was maintained at 100 volts.

Effect of Transducer-Specimen Interface Conditions

Ultrasonic waves generated by a transducer are transmitted into the specimen if they are adequately coupled. It was observed that a variation of the couplant thickness had a significant effect on the amplitude of the signal detected by the receiving transducer. Fig. 4 shows the variation of the relative receiver signal amplitude versus the transducer-specimen interface pressure. Fig. 5 shows the variation of the relative receiver signal amplitude versus the change in couplant thickness. The exact couplant thickness δ was not determined. However, using an epoxy (Devcon "5 Minute" brand)

*This value of stress which appears high is based on the AET calibration curve and the assumption that the transducer response is linear over the voltage range 0 to 300 volts.

as the couplant, the minimum couplant thickness δ_{\min} was determined to be 0.0005 cm (0.0002 in). Note that both Figs. 4 and 5 are plotted for 0.8 MHz. Fig. 6 shows the "saturation pressure" versus the frequency.

As a result of the above investigations, it was found that:

1. The amplitude of the received signal generally increases with increasing transducer-specimen interface pressure or decreasing couplant thickness. There exists a pressure called the "saturation pressure" which is defined as the minimum transducer-specimen interface pressure that results in the maximum output signal amplitude, all other factors being held fixed. Any further increase in transducer-specimen interface pressure beyond the saturation pressure does not increase the output signal amplitude. There is also a minimum couplant thickness defined as δ_{\min} which occurs at the saturation pressure.
2. The saturation pressure is a function of frequency and the transducer used. The effect of the couplant on the saturation pressure is marginal for the two couplants tested.
3. If the interface pressure is very carefully reduced at any point before or after reaching the saturation pressure, the output signal does not change when either AET SC-6 or Sperry 50A4084 is used. This indicates that the couplant thickness and uniformity are maintained even if the pressure is decreased and that the couplant thickness is the crucial parameter for signal amplitude.

4. The amplitude of the receiver signal depends greatly on the type of couplant used. In the frequency range of 0.25 - 2 MHz, the amplitude of the received signal with the AET SC-6 is 2 to 3 times higher than with the Sperry 50A4084. For frequencies higher than 2.5 MHz this behavior is reversed.

Velocity and Attenuation of Longitudinal and Shear Waves in Cast Epoxy Matrix and Composite

Velocity and attenuation of longitudinal and shear waves propagating in the epoxy matrix (3501-6) and in the principal directions of the unidirectional graphite epoxy composite (AS/3501-6) are shown in Figs. 7 to 13. The results indicate that the group velocities of stress waves are constant for each mode over the indicated range of frequencies and thus, both media can be regarded as nondispersive. For a nondispersive medium, the phase and group velocities are identical. The wavelength λ can be computed from the phase velocity C_p and the frequency ω as

$$\lambda = \frac{2\pi C_p}{\omega} \quad (3)$$

Based on the wave velocities shown in Figs. 7 and 11, the wavelengths for each mode can be calculated using eqn. (3) and the results are plotted in Fig. 14. Note that the velocities (Figs. 7 and 11) and the wavelengths (Fig. 14) for the epoxy matrix lie between the corresponding results for the x_2 and x_3 directions of the fiber composite.

The attenuation of longitudinal waves propagating in the x_3 direction of the composite (Fig. 10) is large compared with the other longitudinal modes. Also, there is significant scatter in the data for this mode. This is probably due to the presence of microdelaminations between the laminae. In order to obtain a statistical value for the attenuation in this mode, fifteen (15) specimens were tested. In addition to the scatter, the average attenuation in the laminate direction can vary significantly depending on the fabrication procedure. Data obtained by Lampert [16] for AS/3501-6 are plotted in Fig. 10 also. These laminates which were fabricated exactly in accordance with [13] have a lower attenuation. It is interesting to note that Lampert's $LW(x_3)$ attenuation is still higher than the $LW(x_2)$ attenuation shown in Fig. 9; and thus the quality of the interlaminar interfaces is still a factor in the $LW(x_3)$ attenuation compared with the $LW(x_2)$ attenuation.

Specimens with two different cross-sectional areas were tested for longitudinal wave propagation. The results shown in Figs. 7 to 9 indicate that there is no effect in the ultrasonic results for these two cross-sectional areas.

The range of test frequency was limited by certain factors. In the lower range of frequency the wavelength of the stress wave was relatively large. Many cycles were needed so that the initial transient cycles did not affect the measurements. In order to provide enough cycles, the wave packet duration had to be increased

In the pulse oscillator. Also, a long specimen was necessary for preventing overlapping of the initial signal and its echoes. The lower end of the frequency range in all the longitudinal wave tests was limited by the maximum practical length of the specimens. The upper end of the frequency range in all longitudinal wave tests was limited by the large amount of material attenuation which made it difficult to distinguish between the transmitted signal and the noise. The lower and upper ends of the frequency ranges in all the shear wave tests were limited by the availability of transducers.

CONCLUSIONS AND RECOMMENDATIONS

An experimental system was designed to measure attenuation and narrow band group velocity of longitudinal and shear waves in graphite fiber epoxy composites (AS/3501-6) and in a cast epoxy matrix (3501-6). The effect of the cross-sectional area of the specimen on velocity and attenuation was investigated in the longitudinal wave mode. For the cross-sectional areas tested, all of which were smaller than the transducer faceplate area, the velocity and attenuation were independent of the size of the specimens. It was found that the type of couplant, the couplant thickness and the transducer-specimen interface pressure have significant effects on the amplitude of the received stress wave. The output amplitude generally increased with (1) increasing couplant viscosity for the AET FC-500 transducers, (2) decreasing couplant viscosity for the Automation transducers, (3) decreasing couplant thickness and (4) increasing transducer-specimen interface pressure. There exists a transducer-specimen interface pressure, called the saturation pressure, above which the output amplitude remains constant at its maximum value.

Velocity and attenuation were found to be independent of the amplitude of excitation in the range tested. Thus, the composite and the epoxy matrix can be described as linear viscoelastic materials for the strain excitation considered (from approximately zero to 0.0003). Group velocities of the longitudinal and shear

waves in both the graphite epoxy composite and the epoxy matrix were found to be independent of frequency for the range examined. Thus, the graphite epoxy composite and the epoxy matrix can be considered as nondispersive media. The various velocities for the epoxy matrix were intermediate to the corresponding velocities for the two directions of the composite orthogonal to the fiber direction.

Attenuation of longitudinal and shear waves in both the graphite epoxy composite and the epoxy matrix was found to be frequency dependent. In the composite the attenuation of the longitudinal stress wave was the smallest in the fiber direction and largest in the laminate direction. The attenuation of the shear wave was smallest in the direction perpendicular to the fibers (x_2) with particle motion in the fiber direction and largest in the laminate direction with particle motion in the direction perpendicular to the fibers (x_2).

The attenuation of the composite for longitudinal waves propagating in the laminate direction was sensitive to the interlaminar quality of the composite. Thus, this mode of attenuation may be a useful parameter to monitor in the quality control of fabricated panels and also in the nondestructive evaluation of composites subject to progressive damage, such as during fatigue. Because the attenuation changed rapidly in the higher frequency range (approximately above 1 MHz), NDE should be conducted above 1 MHz to utilize the ultrasonic detection sensitivity.

REFERENCES

1. A. Vary, "Nondestructive Evaluation Technique Guide", NASA SP-3079, 1973.
2. J. H. Williams, Jr. and D. M. Egan, "Acoustic Emission Spectral Analysis of Fiber Composite Failure Mechanisms", Materials Evaluation, Vol. 37, No. 1, January 1979, pp. 43-47.
3. A. Vary and K. J. Bowles, "Ultrasonic Evaluation of the Strength of Unidirectional Graphite-Polyimide Composites", NASA Technical Memorandum TM-73646, April 1977.
4. A. Vary and K. J. Bowles, "Use of an Ultrasonic-Acoustic Technique for Nondestructive Evaluation of Fiber Composite Strength", NASA Technical Memorandum TM-73813, February 1978.
5. A. Vary and R. F. Lark, "Correlation of Fiber Composite Tensile Strength with the Ultrasonic Stress Wave Factor", NASA Technical Memorandum TM-78846, April 1978.
6. D. T. Hayford, E. G. Henneke, II, and W. W. Stinchcomb, "The Correlation of Ultrasonic Attenuation and Shear Strength in Graphite-Polyimide Composites", Journal of Composite Materials, Vol. 11, October 1977, pp. 429-444.
7. James H. Williams, Jr., and Beth Doll, "Ultrasonic Attenuation as an Indicator of Fatigue Life of Graphite/Epoxy Fiber Composite", NASA CR-3179, 1979.
8. J. S. Whitter and J. C. Peck, "Experiments on Dispersive Pulse Propagation in Laminated Composites and Comparison with Theory", Journal of Applied Mechanics, Volume 36, No. 3, Transactions of the ASME, Volume 91, Series E, September 1969, pp. 485-490.
9. J. R. Asay, "Ultrasonic Wave Velocity - Temperature Studies in Several Plastics, Plastic Foams, Nose-Cone Materials, and Metals", Air Force Weapons Laboratory, TR NO. AFWL-TR-65-188, March 1966.
10. T. R. Touchert, A. N. Guzelsu, "An Experimental Study of Dispersion of Stress Wave in a Fiber-Reinforced Composite", Journal of Applied Mechanics, Volume 39, October 1972, pp. 98-102.
11. H. J. Sutherland, "Dispersion of Acoustic Waves by Fiber-Reinforced Viscoelastic Material", Journal of the Acoustical Society of America, Volume 157, No. 4, April 1975, pp. 870-875.

12. M. P. Felix, "Attenuation and Dispersion Characteristics of Various Plastics in the Frequency Range 1-10 MHz", *Journal of Composite Materials*, Volume 8, July 1974, pp. 275-287.
13. "Graphite Materials", Hercules Incorporated, Systems Group, Bacchus Works, Magna, Utah, April 1976.
14. ASTM, "Standard Method of Test for Fiber Content of Fiber Reinforced Resin Composites", ASTM, Part 36, D3171-73, 1976.
15. H. N. Hashemi, "Ultrasonic Wave Propagation in Graphite Fiber Composites", S.M. Thesis, Department of Mechanical Engineering, M.I.T., May 1979.
16. N. R. Lampert, "Ultrasonic Nondestructive Evaluation of Graphite Fiber Epoxy Laminates Subjected to Tensile Fatigue and Impact Loading", S.M. Thesis, Department of Mechanical Engineering, M.I.T., August 1979.

TABLE 1: Properties of Hercules AS/3501-6 Graphite Fiber Epoxy Composites*

| AS/3501-6 | Tensile Modulus | Other Properties |
|--------------------------------|--|--|
| 0° Composite (x_1 axis) | 112 GN/m ² (16.25 mpsi) | 0°-90° (x_1 - x_2) Shear Modulus: 4.8 GN/m ² (0,695 mpsi) Mass Density: 1.467 gm/cm ³ (0.053 lbm/in ³) Fiber Volume Fraction: 53% Void Volume Fraction: 6.4% [†] Cured Per-Ply Thickness: 0.0152 cm (0.006 in) |
| 90° Composite (x_2 axis) | 11.67 GN/m ² (1.69 mpsi) | |
| 90° Composite (x_3 axis) | 8.58 GN/m ² (1.24 mpsi) | |
| Epoxy Matrix (3501-6) | 8.94 GN/m ² (1.29 mpsi) | Shear Modulus: 2.07 GN/m ² (0.30 mpsi) Mass Density: 1.226 gm/cm ³ (0.0443 lbm/in ³) |

*Material was as produced in Composite Materials and Nondestructive Evaluation Laboratory, Mechanical Engineering Department, M.I.T., for this study. Modulus values were based on measured wave speeds.

[†]Void volume fraction was determined in accordance with ASTM D3171-73 [14].

TABLE 2: Characteristics of Transducers Used in Ultrasonic Measurements

| Transducer | Type | Wear Plate Diameter | Specified Frequency Range |
|---|--------------|----------------------|---------------------------|
| Acoustic Emission Technology (AET) FC-500 | Longitudinal | 2.30 cm (0.91 in) | 0.1 - 2 MHz |
| Automation Industry 57K0353 | Longitudinal | 2.70 cm (1.06 in) | 2.5 - 7 MHz |
| Automation Industry 57K0437 | Longitudinal | 2.70 cm (1.06 in) | 7 - 14 MHz |
| Automation Industry 57K0352 | Shear | 1.50 cm (0.59 in) | 0.5 - 4 MHz |

TABLE 3: Propagation and Particle Motion Directions for Measurements of Group Velocity and Attenuation of Longitudinal and Shear Waves

| | Propagation Direction | Particle Motion Direction | Notation |
|-------------------|-----------------------|---------------------------|--------------------|
| Longitudinal Wave | x_1 | x_1 | LW(x_1) |
| | x_2 | x_2 | LW(x_2) |
| | x_3 | x_3 | LW(x_3) |
| Shear Wave | x_1 | x_2 | SW(x_1); x_2 |
| | x_1 | x_3 | SW(x_1); x_3 |
| | x_2 | x_1 | SW(x_2); x_1 |
| | x_2 | x_3 | SW(x_2); x_3 |
| | x_3 | x_2 | SW(x_3); x_2 |
| | x_3 | x_1 | SW(x_3); x_1 |

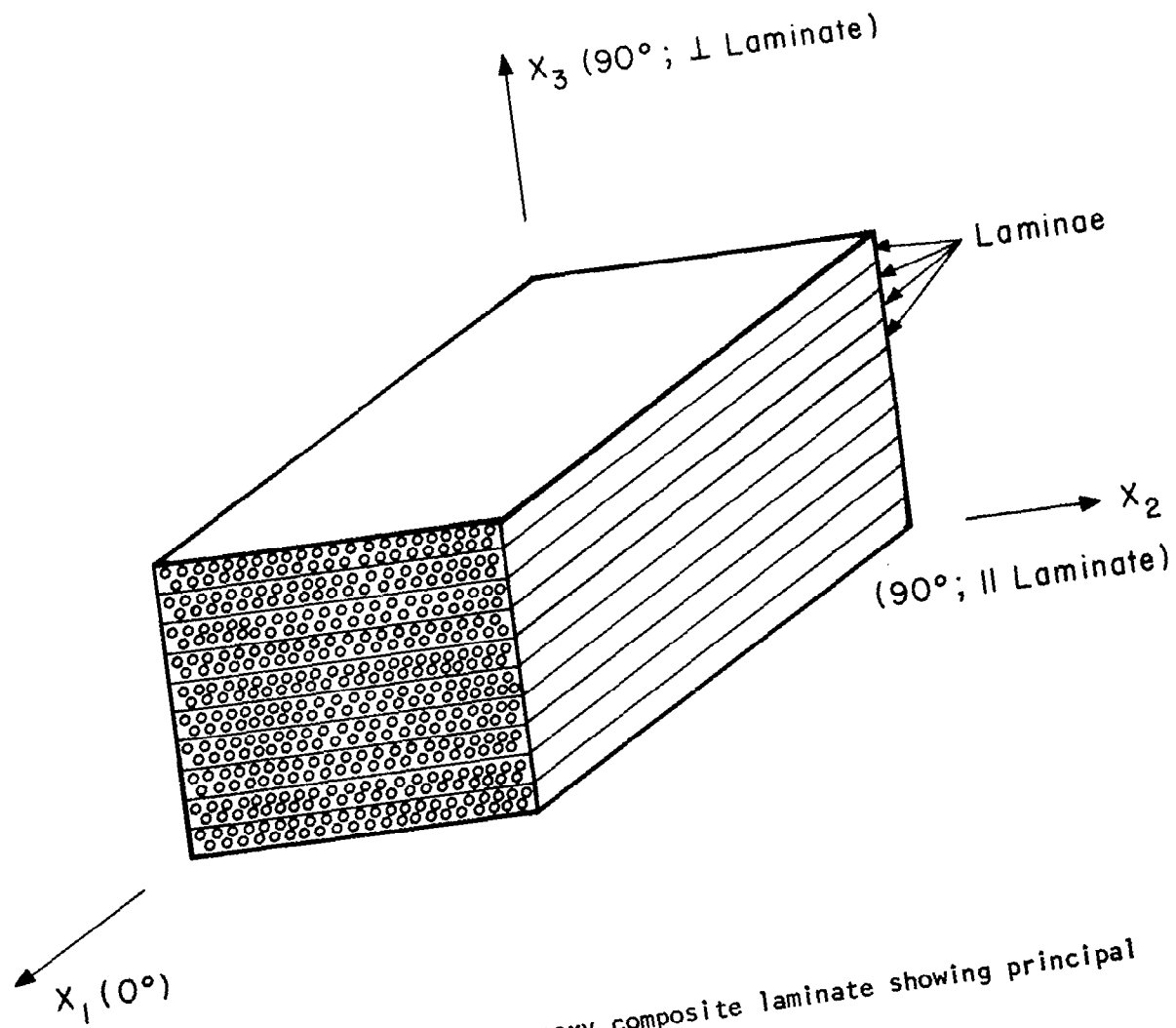
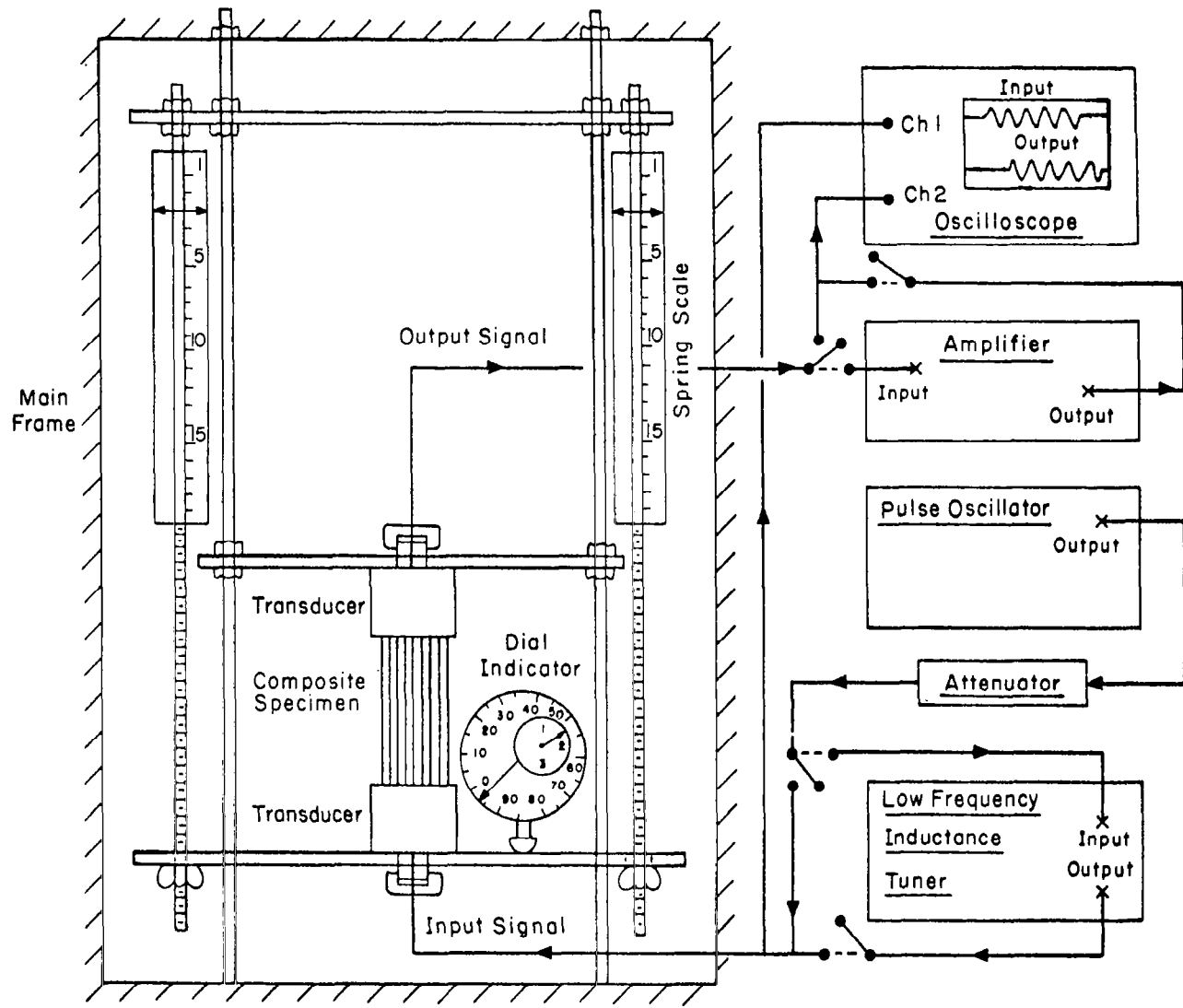
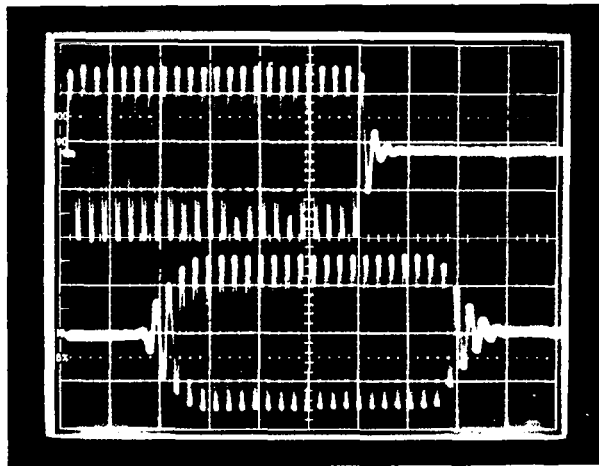

Fig. 1 Schematic of graphite epoxy composite laminate showing principal directions.



Input

Output



Input: 25 Volt/Large Div.

Output: 0.2 Volt/Large Div.

Sweep Rate: 5 μ sec/Large Div.

Frequency: 1.8 MHz

Fig. 3 Typical transmitter (input) and receiver (output) signals.

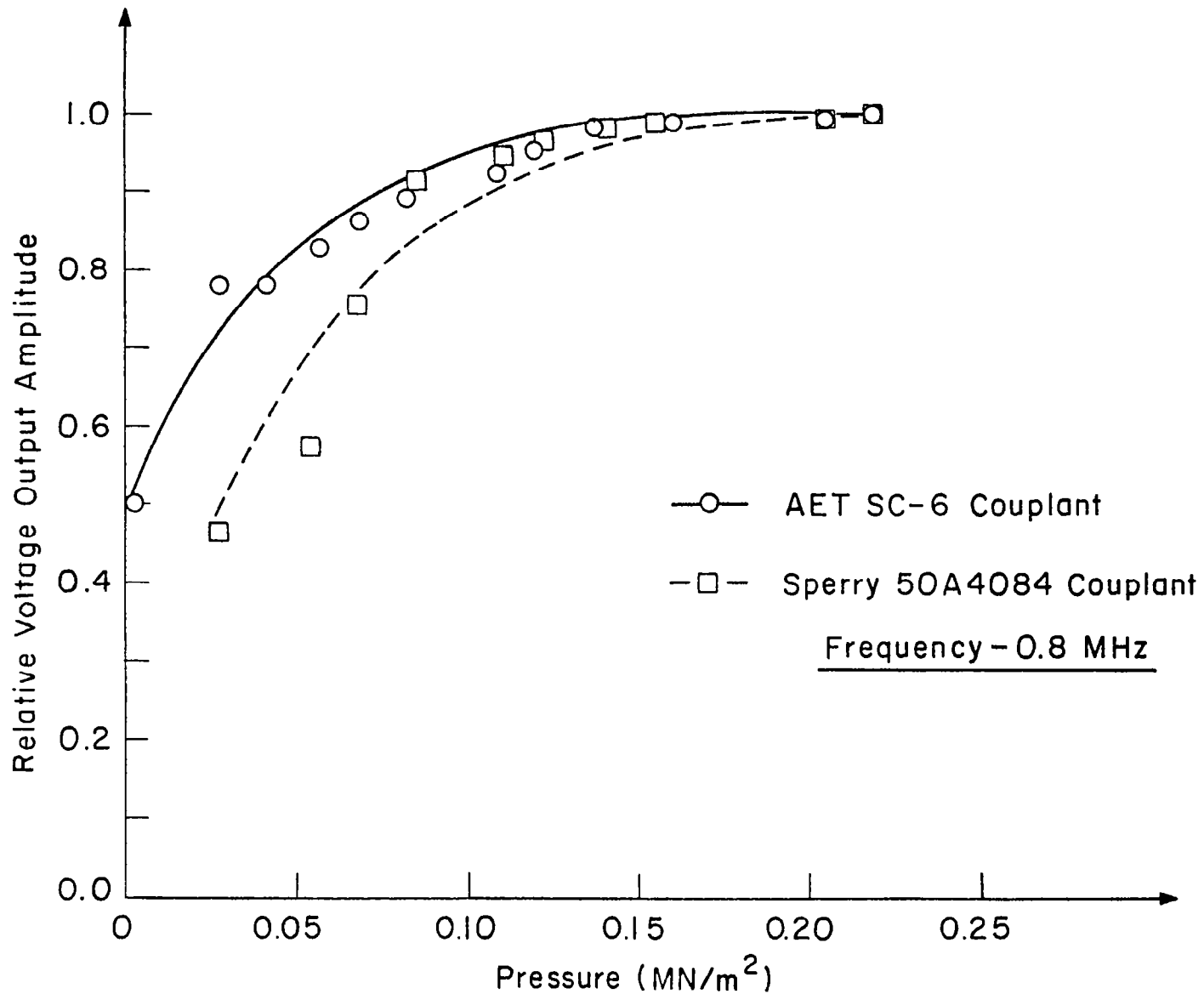

Fig. 4 Variation of relative output amplitude versus transducer-specimen interface pressure.

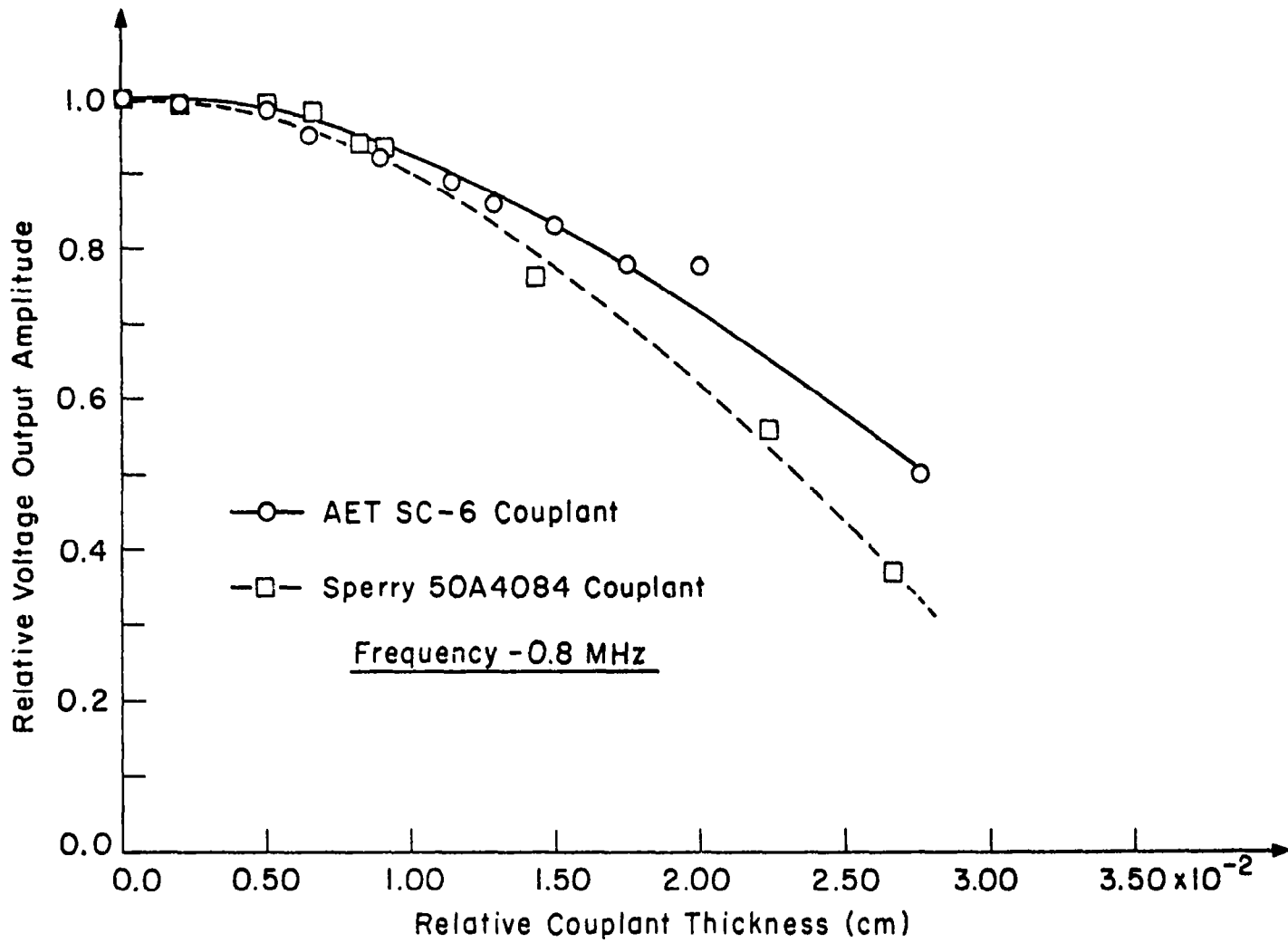

Fig. 5 Variation of relative output amplitude versus relative couplant thickness ($\delta - \delta_{\min}$).

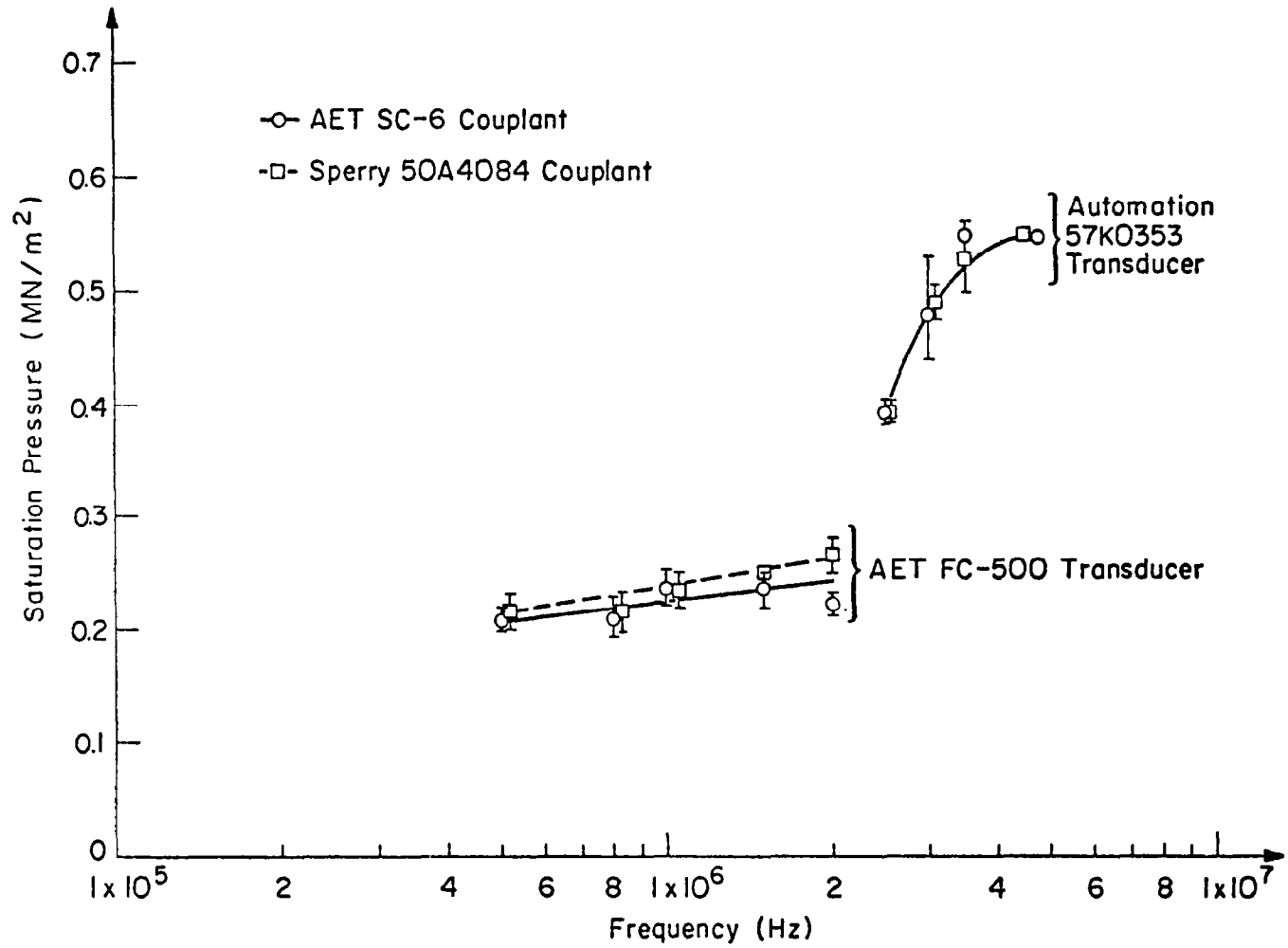

Fig. 6 Variation of saturation pressure versus signal frequency for two longitudinal transducers.

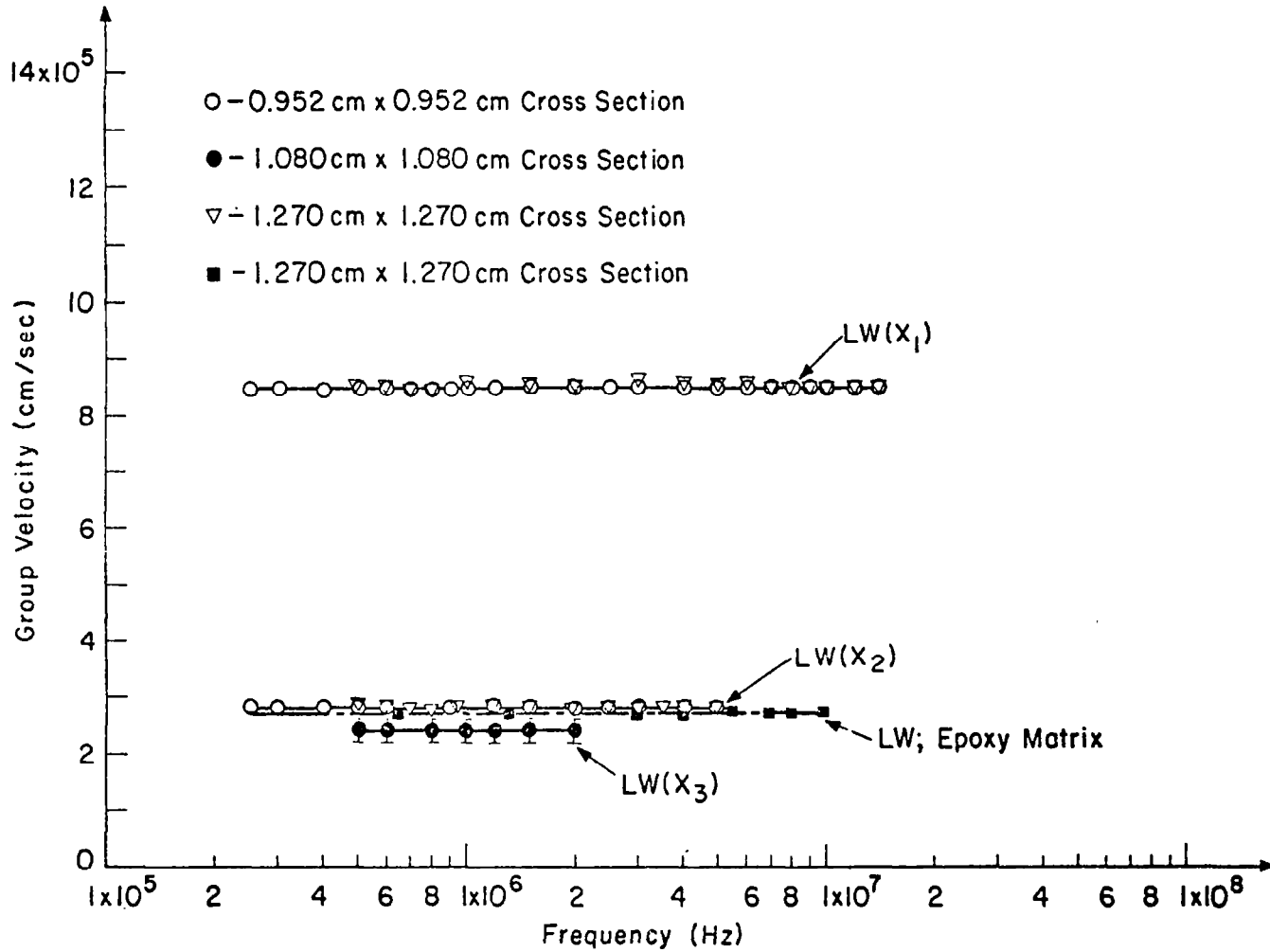

Fig. 7 Longitudinal group velocities versus frequency for the indicated specimens and directions.

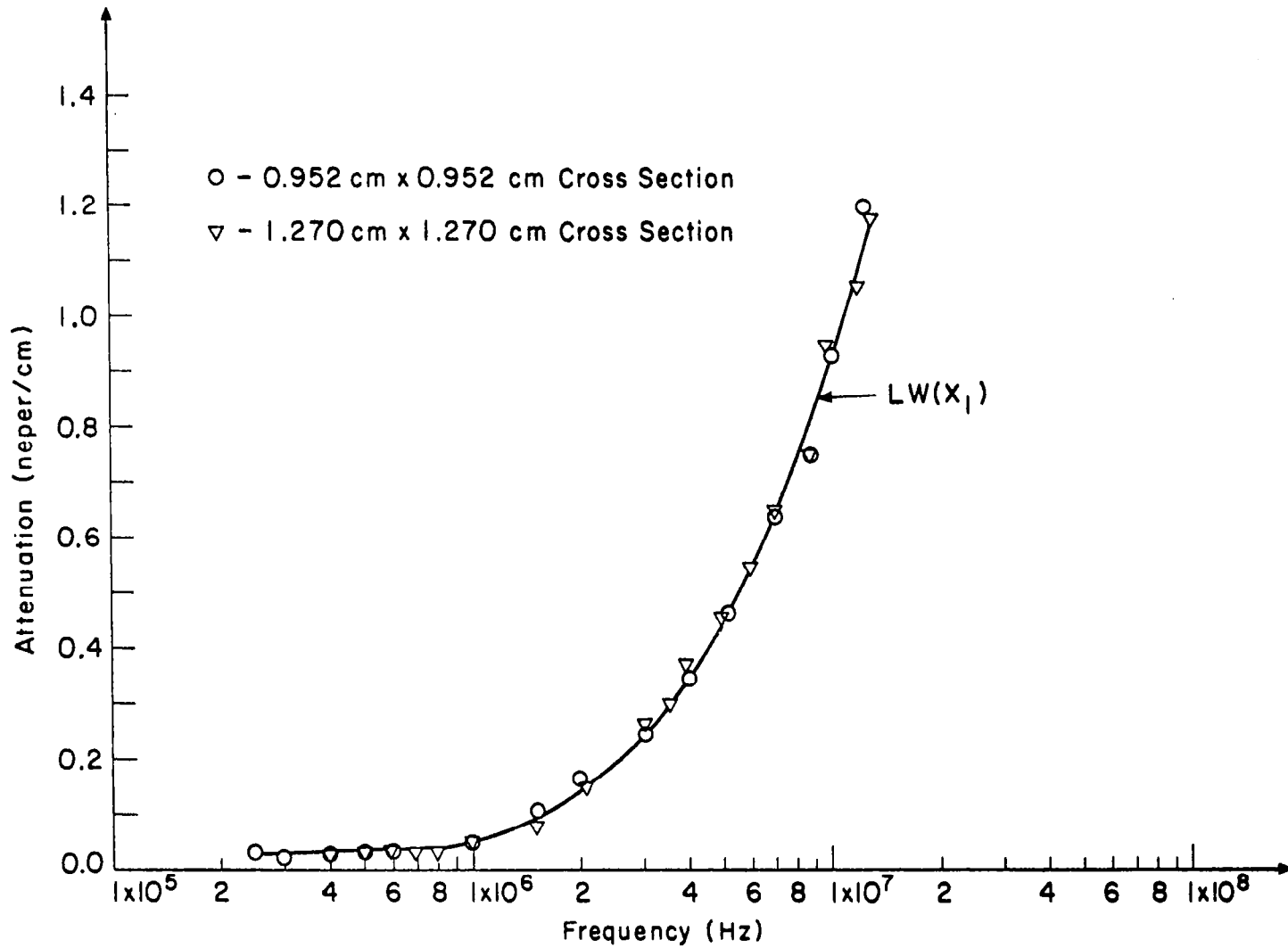

Fig. 8 Attenuation of longitudinal wave versus frequency for 0° specimen.

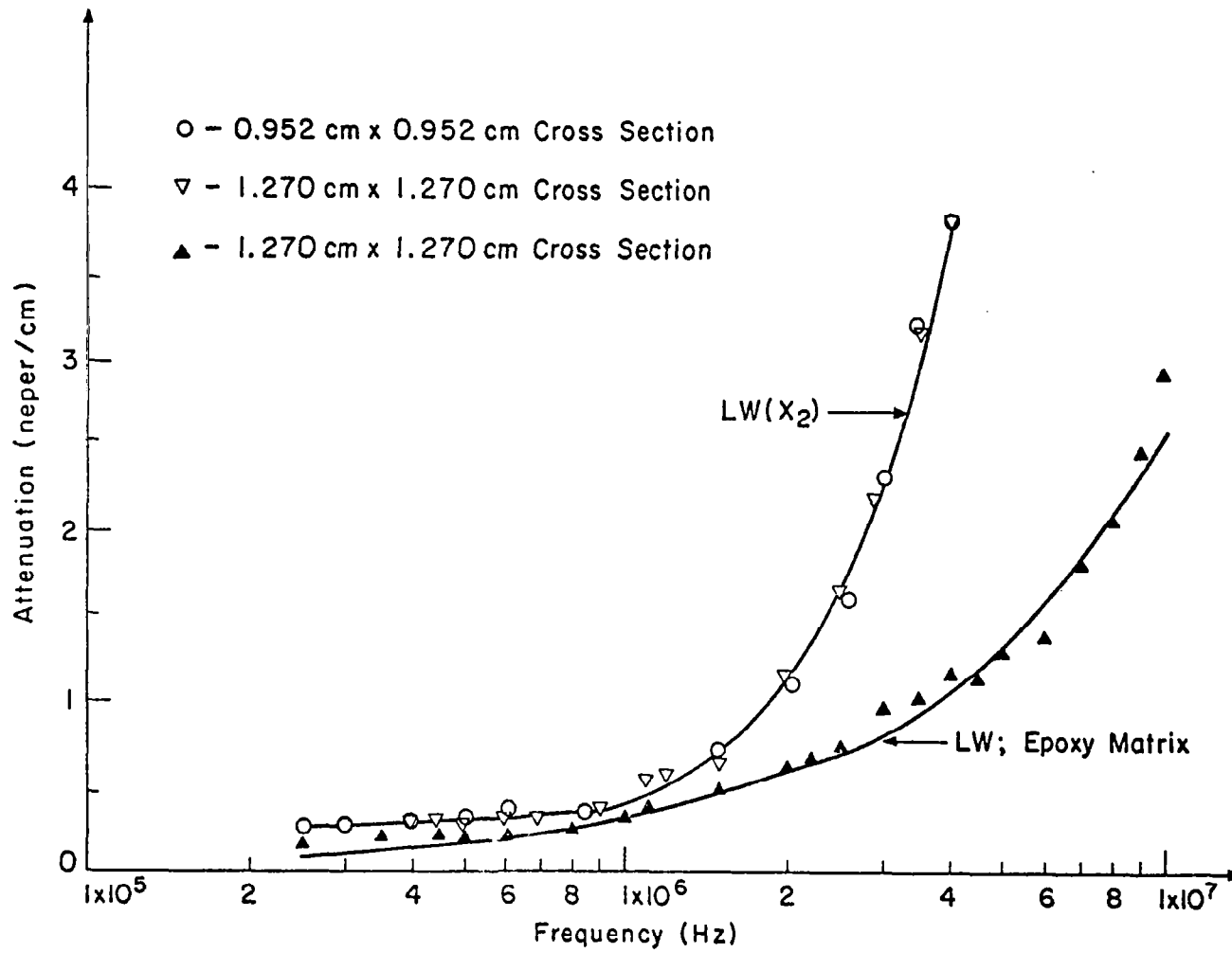

Fig. 9 Attenuation of longitudinal wave for the indicated specimens and directions.

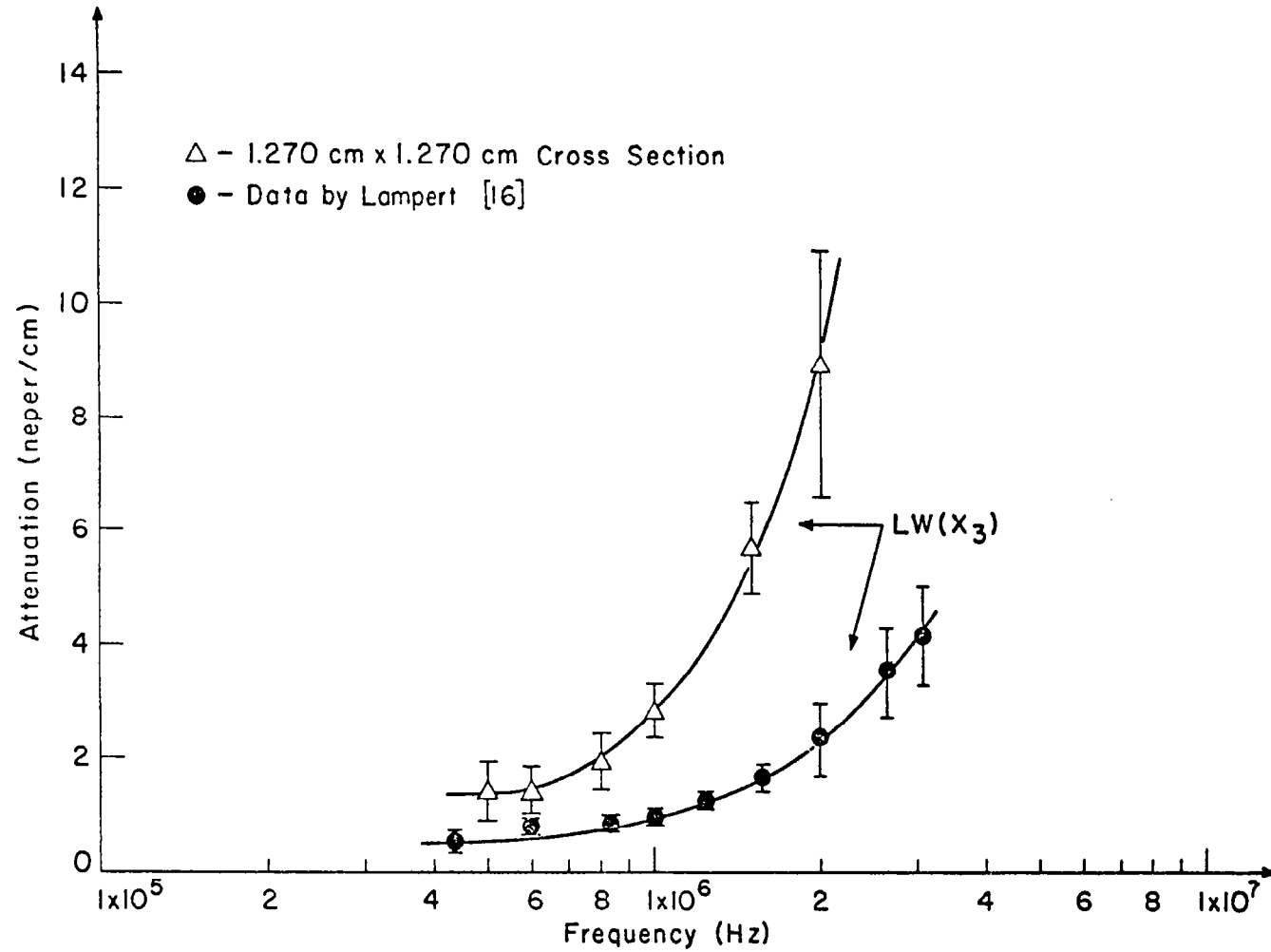

Fig. 10 Attenuation of longitudinal wave perpendicular to the laminate versus frequency for 90° specimen. (Mean values are plotted with brackets indicating the standard deviation about the mean.)

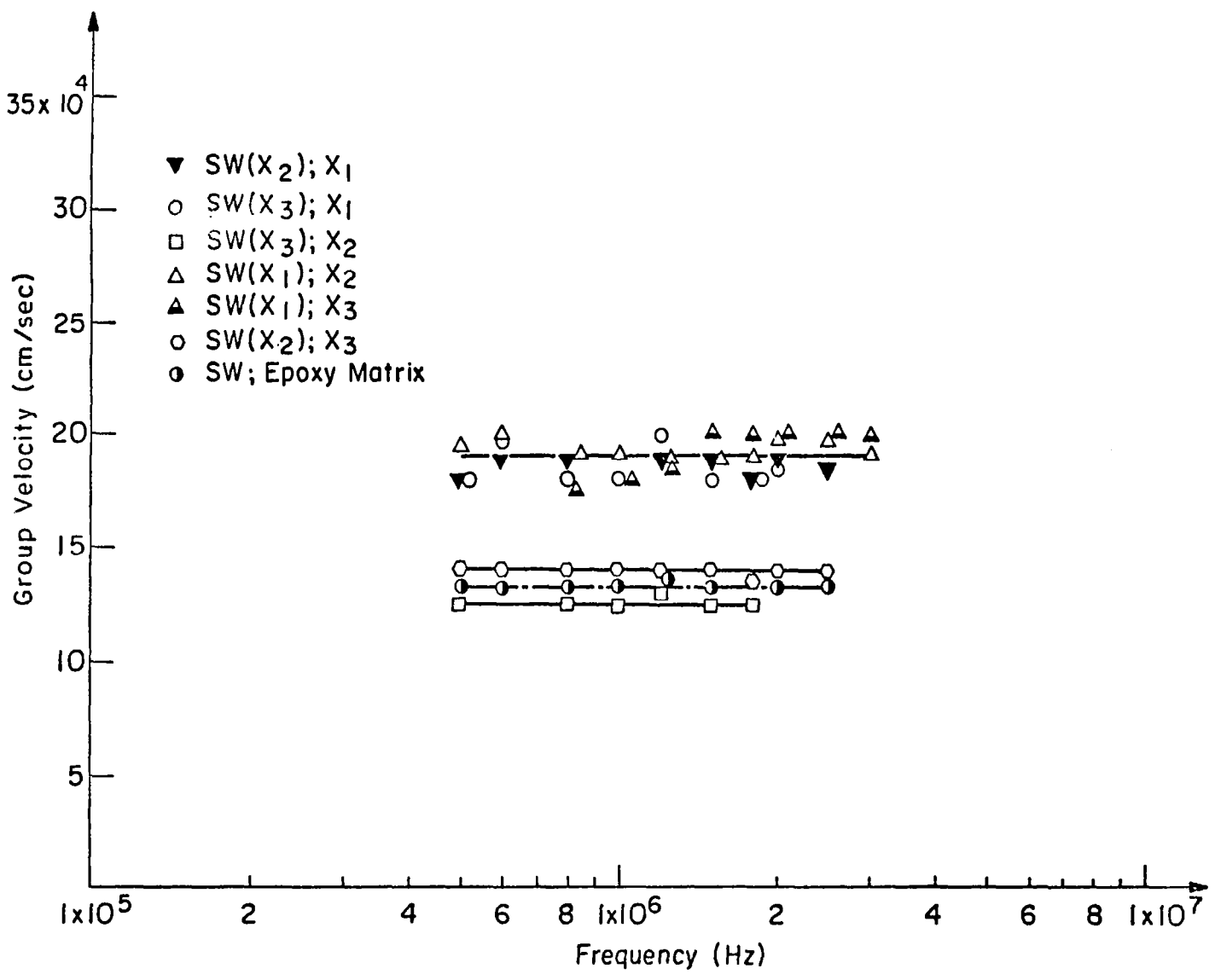

Fig. 11 Shear wave group velocities versus frequency for the indicated specimens and directions. (Specimens had 1.270 cm x 1.270 cm Cross Section.)

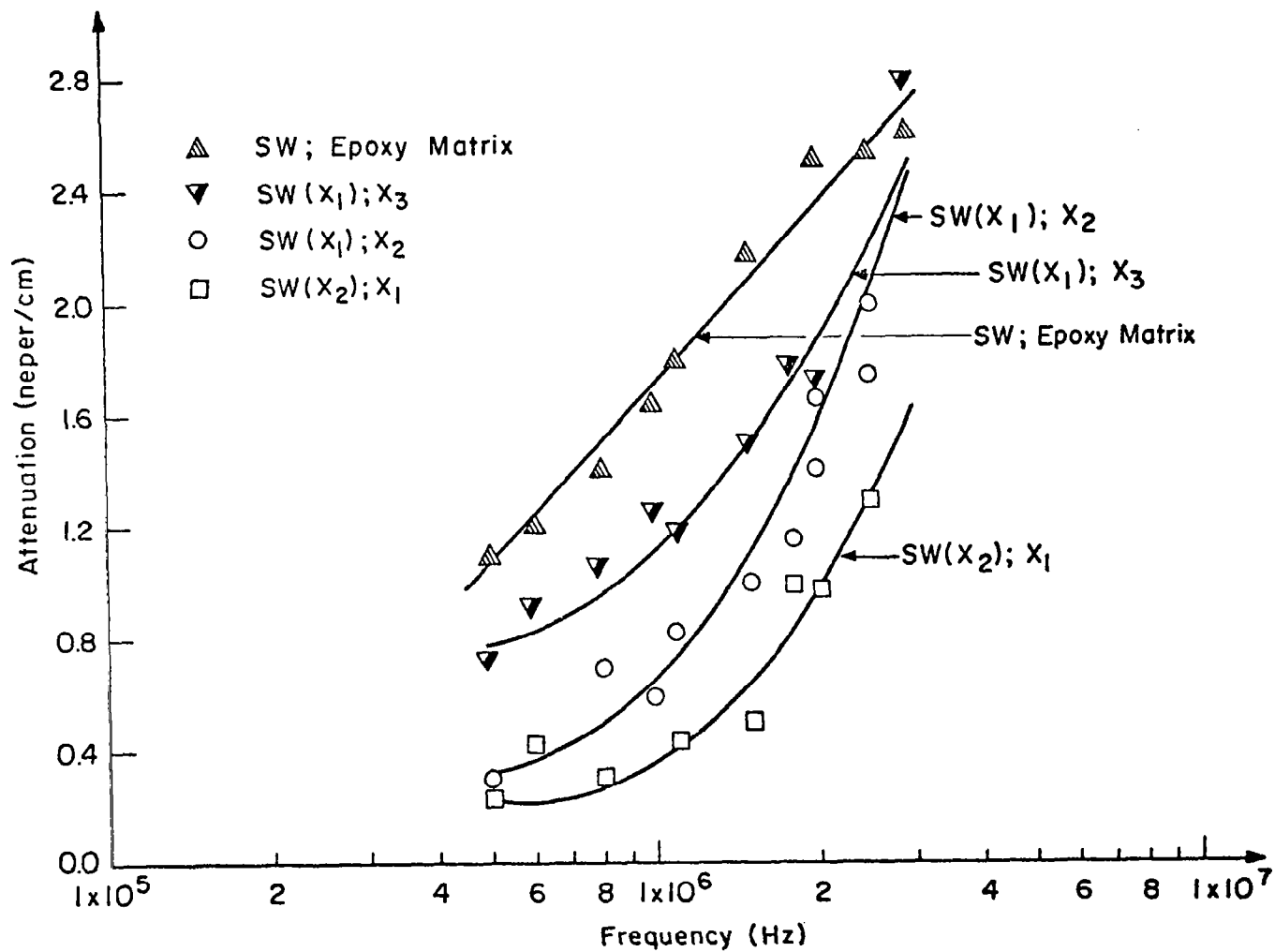

Fig. 12 Attenuation of shear wave in the indicated directions and specimens. (Specimens had 1.270 cm x 1.270 cm Cross Section.)

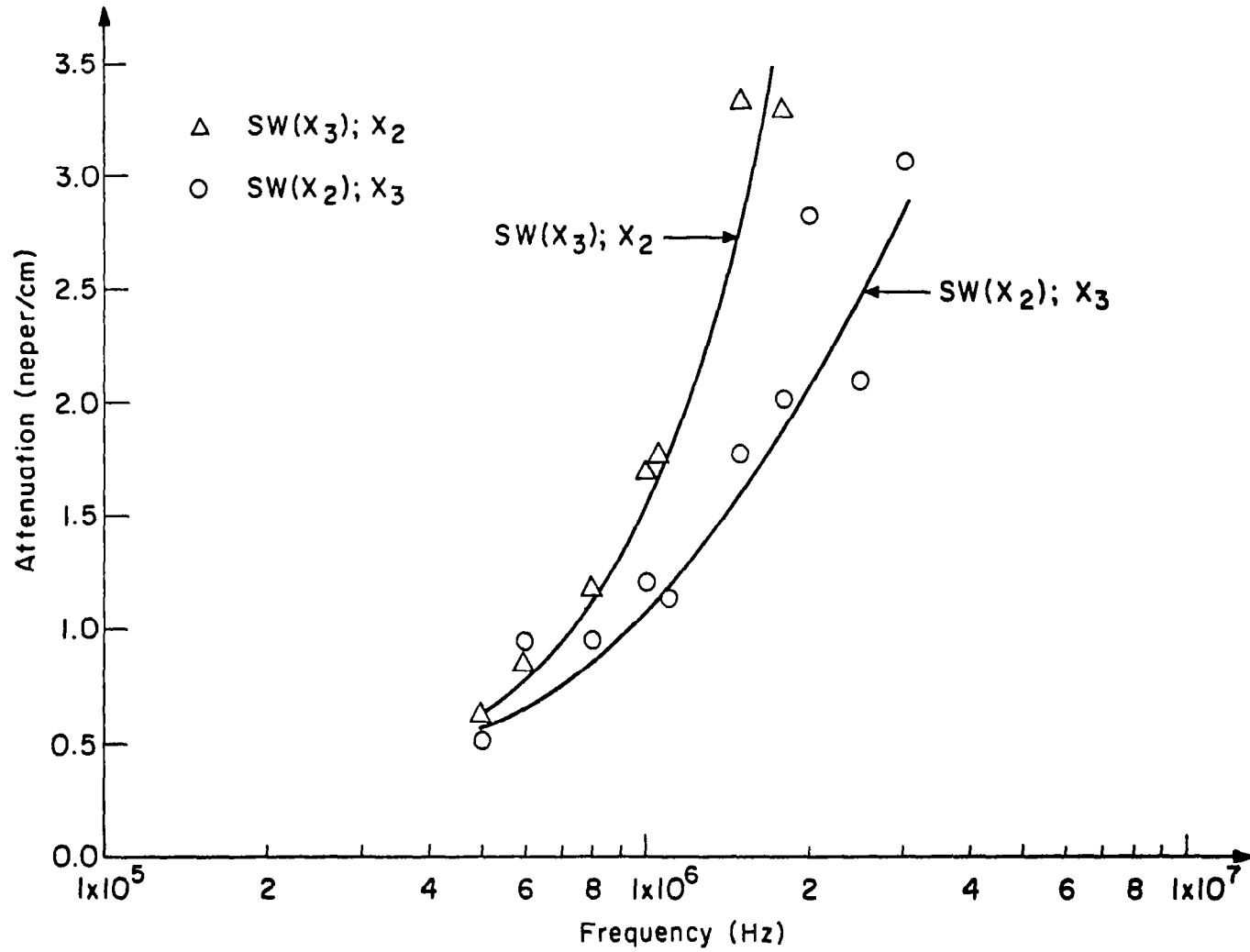

Fig. 13 Attenuation of shear wave in the indicated directions and specimens.
 (Specimens had 1.270 cm x 1.270 cm Cross Section.)

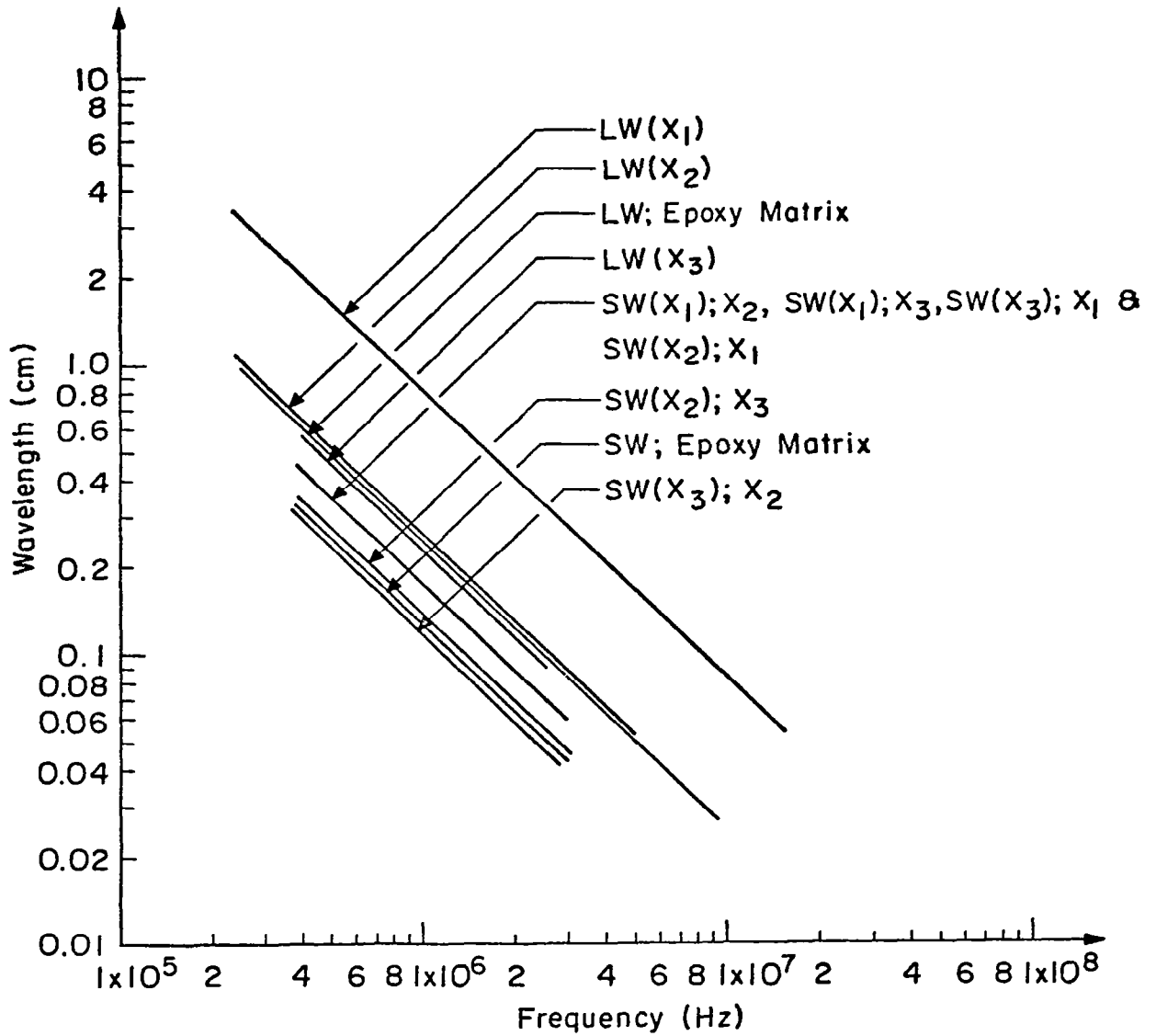

Fig. 14 Wavelengths versus frequency for longitudinal and shear waves in various specimens for the indicated directions.