



<http://www.diva-portal.org>

## Postprint

This is the accepted version of a paper published in *Requirements Engineering*. This paper has been peer-reviewed but does not include the final publisher proof-corrections or journal pagination.

Citation for the original published paper (version of record):

Svahnberg, M., Gorschek, T., Nguyen, T., Nguyen, M. (2015)  
Uni-REPM: a framework for requirements engineering process assessment.  
*Requirements Engineering*, 20(1): 91-118  
<http://dx.doi.org/10.1007/s00766-013-0188-1>

Access to the published version may require subscription.

N.B. When citing this work, cite the original published paper.

Permanent link to this version:

<http://urn.kb.se/resolve?urn=urn:nbn:se:bth-6317>

## Uni-REPM – a Framework for Requirements Engineering Process Assessment

Mikael Svahnberg · Tony Gorschek · Thi  
Than Loan Nguyen · Mai Nguyen

the date of receipt and acceptance should be inserted later

**Abstract** *Context.* It has been shown that potential business benefits could be achieved by assessing and improving the requirements engineering (RE) process. However, process assessment models such as CMMI and ISO9000 only cover RE shallowly. Tailored models such as REGPG and REPM, on the other hand, do not cover market-driven requirements engineering. Other attempts, such as MDREPM covers market-driven requirements engineering, but correspondingly neglects bespoke requirements engineering. Moreover, the area itself has evolved so practices that once were cutting edge are now commonplace.

*Objectives.* In this article we develop and evaluate a unified requirements engineering process maturity model (Uni-REPM) that can be used in a market-driven as well as a bespoke context. This model is based on REPM, but has evolved to reflect contemporary requirements engineering practices.

*Methods.* Uni-REPM is primarily created based on a systematic literature review of market-driven requirements engineering practices and a literature review of bespoke practices.

*Conclusions.* Based on the results, Uni-REPM is formulated. The objective of Uni-REPM is twofold. Firstly, it is expected to be applicable for assessing the maturity of RE processes in various scenarios where an organization would use different development approaches. Secondly, it instructs practitioners about which RE practices to perform and their expected benefits. As an assessment instrument, Uni-REPM provides a simple and low cost solution for practitioners to identify the status of their RE process. As a guidance tool, Uni-REPM lessens the gap between theoretical and practical worlds by transferring the available RE technologies from research to industry practice.

---

Published in Requirements Engineering Volume 20, Issue 1, pp. 91–118. DOI:10.1007/s00766-013-0188-1

---

Mikael Svahnberg · Tony Gorschek · Thi Than Loan Nguyen · Mai Nguyen  
Blekinge Institute of Technology, SE-371 79 Karlskrona SWEDEN  
E-mail: {Mikael.Svahnberg | Tony.Gorschek}@bth.se, {thanhloan2812.nguyen | main-  
guyentp}@gmail.com

## 1 Introduction

It has been shown that significant business benefits could be achieved by preventing problems as early as the Requirements Engineering (RE) phase instead of waiting until the project is finished [76]. For example, Hall et al. [31] report that a large proportion (48%) of the development problems stem from problems with the requirements. Moreover, fixing requirements related problems consumes a high cost of rework in later states [9,51].

However, despite its important role, there are many empirical studies on industrial projects reporting poor RE practices [31,39,64,63,1,65,28]. Problems reported include a lack of well-defined processes and guidelines for using tools and methods, inadequate user involvement in the processes, overlooking the need for traceability, and rare usage of the available modelling techniques [39,62]. In market-driven RE, the vast number of stakeholders makes it difficult to elicit and manage the requirements, especially since the mass of requirements is continuously expanding and requirements may be stated on different levels of abstraction [43,25]. Moreover, the requirements are often volatile and changed [1], and there is a need to balance between market-pull and technology push [25].

There exist several requirements engineering process improvement frameworks, aiming at bridging this gap between best practices and practised best, for example the Good Practice Guide [77], and the Requirements Engineering Process Maturity Model (REPM) [27]. Process assessment frameworks such as CMMI [15] and SPICE [78] also cover requirements engineering, although only shallowly since the scope of these frameworks are much bigger than just requirements engineering. These frameworks all focus on bespoke requirements engineering and have not evolved along with requirements engineering practices in industry. Hence, there are practices not covered at all by these frameworks, and other practices are ranked as being very advanced whereas in current state of practice they are the common norm. Attempts have been made to introduce process assessment frameworks for market-driven requirements engineering, for example MDREPM [26]. However, these attempts usually focus too much on market-driven requirements engineering and thus makes the framework unusable in a bespoke setting or vice versa, whereas industry in fact often uses a combination of bespoke and market-driven requirements engineering [25,75,74]. Moreover, to forego our own conclusions slightly, there is a large number of practices that are valid and have been validated in both market-driven and bespoke requirements engineering contexts, and thus it makes sense to perform process assessment and process improvement using an assessment framework that is universally applicable for all types of requirements engineering.

The goal of this article is thus to introduce a modern process assessment framework for requirements engineering that encompasses current best practices, but also enables process assessment of both bespoke and market-driven projects. This framework, Uni-REPM, is intended as an instrument for assessing RE process maturity as well as to offer a concrete, complete, and contemporary view of state of the art in requirements engineering, so that researchers and practitioners alike may get an overview of which requirements engineering practices that have been proposed and empirically validated.

Uni-REPM is constructed based on studies of “good practices”<sup>1</sup> which include an extensive systematic review on market-driven RE and an intensive literature review on bespoke RE. We present a unified framework for bespoke and market-driven requirements engineering in order to facilitate for the users that do not need to know a priori what type of development situation they are assessing, and in order to cover the entire spectrum from market and domain analysis down to, e.g., specific elicitation practices. We present the results as an assessment framework to improve the usability of the results, and in so doing we categorise the practices into process areas for easy navigation, and introduce maturity levels on practices to present consistent and coherent packages of requirements engineering practices.

Uni-REPM constitutes a synthesis of more than 150 requirements practices gathered from more than 50 different sources, where the empirical status of each practice has been weighed along with the motivation for employing the practice in the first place. Together this forms a consistent and coherent set of practices on three different levels where each level addresses specific process goals. For industry practitioners, this provides a useful tool to assess the current state of requirements engineering practiced in a company and identify potential process improvements against contemporary, and empirically proven best practices. For researchers, this provides a collection of empirically validated requirements engineering practices, that enables reflection on current state of practice, current state of the art, and to identify areas where more research and/or empirical validation is needed.

The remainder of this article is organised as follows. In Section 2 we define the research questions that guide our work. In Section 3 we conduct a systematic literature review to derive market-driven requirements engineering practices, followed by a literature review in Section 4 for bespoke requirements engineering practices. These are merged into a single framework, Uni-REPM, in Section 6. Traceability information from Uni-REPM back to the literature sources (the results of the two literature reviews) is presented in Section 7, and validity threats are discussed in Section 8. Finally, the article is concluded in Section 9.

## 2 Research Questions

The goal of this research is to create a modern requirements engineering process assessment framework containing validated requirements engineering practices. In order to elicit these practices we formulate the following research questions for this study:

- *RQ1*. What are “good practices” for market-driven requirements engineering?
- *RQ2*. What are “good practices” for bespoke requirements engineering?
- *RQ3*. What trends can be seen with respect to “good practices” for market-driven and bespoke requirements engineering?

The intention of these research questions is to elicit a complete and contemporary set of empirically validated and motivated requirements engineering practices covering both market-driven and bespoke requirements engineering, that can be synthesized into a requirements engineering process assessment framework, Uni-REPM.

---

<sup>1</sup> By “good practices” we denote activities in RE that have been empirically validated in industry, and may benefit practitioners if they are implemented in an industry project.

For RQ1 we use a systematic literature review, as described in Section 3, and for RQ2 we use a literature review, as described in Section 4. Using the material produced for RQ1 and RQ2, we are able to answer RQ3.

### 3 MDRE Practices

A systematic literature review is “a means of identifying, evaluating and interpreting all available research relevant to a particular research question, topic area, or phenomenon of interest” [48]. We use this methodology since the main purpose of the methodology itself conforms to the goal of our study. Since market-driven RE (MDRE) has been gaining increased interest in the software development community [1,74] and the research studies are scattered around various sources [74], a systematic review is a fair and thorough means to find an answer to RQ1 in comparison to a traditional literature review [48]. Please note that while we adopt the *methodology* of a systematic review, we process the *outcome* in a slightly different way than what is traditionally expected of a systematic literature review (see e.g. Webster & Watson 2002 [83]).

The aim of this study is to develop a maturity assessment model specifically for the RE process. This construction is governed by three primary design objectives, namely:

- *Feasibility* The practices extracted from the literature reviews have to be validated in industry. For market-driven RE, the validation status of each practice is recorded and used to assess the practices. For bespoke RE, the models used as input are partially selected because they are already validated in industry.
- *Universality* Practices in Uni-REPM shall be applicable in as many contexts as possible.
- *Light-Weightedness* Uni-REPM shall be a light-weight process assessment framework, not overladen with “good to have” practices or complicated assessment methods. The tools for assessing shall be easy to answer, the structure of the model shall be simple and easy to navigate, and the contents of the model shall be well presented and self-contained to as high a degree as possible. To this end, we use only validated and universally applicable practices, and an already established and validated structure for Uni-REPM, i.e. the one used by its ancestor REPM.

These design principles are similar to those used when creating the original REPM [27], and together provides a cost-effective way to get an overview of the current requirements engineering process in an organisation along with useful pointers for process improvement efforts. In line with these design objectives, we conduct the systematic literature review in this study to (a) identify market-driven RE practices, (b) identify their empirical support, and (c) rationale for the practices. Empirical support in this study refers to validation results reported from applying the identified practices in case studies, sample projects and in industry. Rationale in this study is mainly indicated by how well motivated a practice is (e.g. empirical data support for the need of the practice).

Below, we present the different steps involved in designing and conducting the systematic literature review in further detail. For this systematic literature review we follow the process suggested by Kitchenham et al. 2007 [48].

### 3.1 Necessity of a Systematic Literature Review

The aim of this study is to develop a maturity assessment model specifically for the RE process. This causes a need to gather all MDRE practices in literature. In order to determine whether this had already been done, a preliminary search was performed looking for the search string: “Requirements Engineering” AND “Systematic Review” AND “market” within the Article Title, Abstract, and Keywords, in the Inspec and Compendex databases. This was done January 15, 2010, and no relevant results were found. One systematic literature review in the area of Release Planning had been conducted [79], but no extensive synthesis of MDRE practices has been performed. Thus, we confirm the need to execute this systematic literature review.

### 3.2 Revised Research Questions

For the sake of the systematic literature review, RQ1 is broken down into three sub-questions, as presented below. RQ1.1 and RQ1.2 serve to identify market-driven practices, and RQ1.3 identifies the empirical support and/or rationale, in line with the design objectives of Uni-REPM.

- *RQ1.1* What practices are explicitly suggested for market-driven RE?
- *RQ1.2* What practices can be extracted from existing techniques, tools, methods, and models for market-driven RE?
- *RQ1.3* Which practices from RQ1.1 and RQ1.2 are justified for market-driven RE by empirical validation and/or rationale?

### 3.3 Search Strategy

**Databases.** In this study, we used the databases listed in Table 1, since these have a high coverage of publications in software engineering, computer science, management, and information science, are updated often, and primarily contains peer-reviewed articles. IEEE Xplore and ACM Digital Library are included, despite providing mostly duplicates to what is already found through the other databases, in order to ensure as complete a coverage as possible.

We did not explicitly include grey literature in this part of the study. The main reason concerns the credibility of the new model. The goal is to create a one-size-fit-all model so that any organisation may be assessed using the model, regardless of individual characteristics. Therefore, particular experiences and lessons learned reported from specific situations are unsuitable for inclusion. Having said this, one form of grey literature is represented in existing techniques, tools, methods, and models for market-driven RE, and this is covered by RQ1.2.

**Search Terms.** Search terms were formulated in collaboration with a librarian. For constructing the search terms the steps in Table 2 were followed as suggested by Hannay et al. [32], resulting in the set of search terms presented in Table 3. These search strings were applied to search in title, abstract, and keywords in all the selected databases.

**Study Selection.** In order to accurately and effectively extract all the valuable data from identified studies as well as to ensure the consistency of the study,

**Table 1** Databases Used

Database Name
IEEE Xplore
ACM Digital Library
Scopus
Engineering Village (Compendex, Inspec)

**Table 2** Search Terms Construction Process

Step	
1	Major terms are formed from the research questions by identifying the population, intervention, outcome, context and comparison
2	By altering the spellings, identifying alternative terms and synonyms of major search terms
3	By checking the keywords in known papers
4	Brainstorming
4	Boolean OR is used for incorporating search terms of alternative spellings and synonyms
5	Boolean AND is used to link the major terms with other terms and for combing different terms
6	Iterate and refine search terms by performing test searches on different combinations of initial search terms
7	Evaluate test search results; pick random papers from obtained results to check accuracy of search terms

**Table 3** Search Terms

market-driven mass-market consumer market release plan*	AND	requirements	AND	practice technique method tool model approach solution
off-the-shelf packaged software large-scale	AND	requirements engineering		
product management	AND	software		

inclusion and exclusion criteria were generated for the study selection process. The inclusion/exclusion criteria are presented in Table 4. As can be seen, we limit our search between 1992 and February 2010. This is a trade-off between our desire to focus on contemporary RE practices and to minimise any risk of losing seminal papers about MDRE. We performed a study on the research history of MDRE to determine when this field started to receive increased attention. In 1992, Lubars et al. [57] proposed two categories of projects, i.e. customer-specific, and market-driven projects. Since then, the area gained momentum, e.g. with publications by Carmel & Becker 1995 [14], Hutchings & Knox 1995 [34], Potts 1995 [66], Regnell et al. 1998 [69], etc. Since the research field “took off” in 1992, this marks our starting year.

Literature reviews and systematic literature reviews (e.g. [59]) are solely used to find the original studies that, in turn, should fit the basic and detailed inclusion/exclusion criteria. Other than the aforementioned use, we do not include systematic literature reviews or literature reviews in any further analysis.

**Table 4** Detailed Inclusion and Exclusion Criteria

Study Inclusion Criteria	
	The publications are included if they confirm all of the following criteria:
IC1.	The article is written in English.
IC2.	The publication year of the paper is from 1992 to the point of conducting the search (February 2010).
IC3.	The article is peer-reviewed.
IC4.	The title or abstract discusses MDRE or topics related to the research questions.
IC5.	The article is available in full text.
IC6.	The introduction discusses a practice, model, method, technique, or tool in MDRE.
IC7.	The content of the article discusses either of: <ul style="list-style-type: none"> <li>– a summary of practices, models, methods, techniques or tools in market-driven RE</li> <li>– a comparison between practices, models, methods, techniques or tools in market-driven RE</li> <li>– a validation of practices, models, methods, techniques or tools in market-driven RE</li> <li>– a proposal of practices, models, methods, techniques or tools in market-driven RE</li> </ul>
Study Exclusion Criteria	
	The publications are excluded if:
EC1.	The article is a duplicate of an already included article.
EC2.	The article discusses practices of business analysis, marketing or resource scheduling in market-driven requirement engineering.
EC3.	The article is related to specific systems, which have special characteristics that are not widely applicable e.g. grid computing systems or COTS-based systems.
EC4.	The article is specifically about product line development, or notation construction, or component selection for COTS-based systems or aspect-oriented approaches.
EC5.	The article mainly discusses challenges and problems in MDRE but does not provide any beneficial solution or suggestion to solve such problems.

The intention is to create a generic model for requirements engineering process assessment. This can be done in essentially two ways; either by including everything and set up a number of special cases where parts of the model apply and where other parts of the model do not apply, or by excluding practices that are unique for specific contexts. Governed by the design objectives of universality and light-weightedness, we choose the latter approach. Hence, practices designed for a specific context are excluded from further study with the help of exclusion criteria EC2-EC4. EC5 is added to be able to focus on solutions rather than the challenges of market-driven requirements engineering. There is a risk that we hereby exclude practices that may be of use outside the context in which they are introduced, but since they have only been validated inside that context (or we would find them in other publications that are not excluded), there is not sufficient empirical validation of their general applicability.

Inclusion criteria IC1, IC2, and IC3 are checked automatically with the help of options in the searched databases. After this, the selection process loosely follows the two-stage process in Brereton et al. [10]. First, the titles are matched against the inclusion criteria, followed by the abstracts in case the title did not provide sufficient information. Subsequently, the researchers retrieve full texts of the papers not previously rejected. For those papers that can be retrieved, their introductions are reviewed. Finally, the whole publications are read and checked against the inclusion/exclusion criteria in order to obtain the final set of included studies.



**Pilot.** Brereton et al. [10] argues that it is essential to pilot the review protocol in order to reveal problems in different stages of the review process. Accordingly, we adopt a two-staged pilot study approach, between which the review protocol is discussed in order to construct and confirm a common understanding.

First, the third search string was used on the SCOPUS database and IC4 was applied by two of the researchers on 50 random papers in the result set, classifying them as Included, Excluded, or Unsure (needing a joint discussion). Cohen’s Kappa coefficient [16] was calculated to 0.78 which indicates a good agreement level and common understanding of the two researchers. However, the exclusion criteria were revised since many of the papers could satisfy the inclusion criteria but still appeared to be irrelevant for the research goal. Therefore, the researchers had a discussion about the scope of the study, and as a result added exclusion criterion EC4 to the list.

Second, 50 papers were extracted from the Compendex database using the first search string, and applying the same selection method as in the first pilot Cohen’s Kappa returned 0.76 which is still a good agreement. Thus satisfied with the agreement level between the researchers, the full systematic literature review was conducted.

**Quality Assessment Criteria.** The design objectives of Uni-REPM dictate that practices shall be well supported by empirical validation and rationale. Hence, this step is performed mainly to judge the quality and reliability of the rationale or validation proposed in the selected articles. Thus, the quality assessment criteria consists of two questions that are answered with “yes”, “no”, or “partially”:

QC1. Is the idea of the solution fully explained in the study or in other referred studies?

QC2. Can the findings of the study be generalised?

These criteria are assessed and recorded as the selected articles’ full text is studied for data extraction. The idea of a paper is considered as fully explained once the whole context of the study, the motivation for it, the research methodology and the findings are clearly described. Since a large portion of publications in this study is expected to be qualitative, the generalisability of the papers is mainly assessed on the basis of validation context, evaluation method, and findings from the validation steps.

**Data Extraction.** We use a standardised data collection form to extract relevant information to answer the research questions, as presented in Table 5. Extracted data is double-checked by two of the authors to eliminate uncertainties. A pilot study was performed on the data extraction form to ensure that it worked before conducting the full scale systematic review. Some difficulties were found and resolved through discussion among the authors. In case of multiple publications of the same data, the most recent results are used for data extraction and synthesis.

**Data Synthesis.** As the extracted data related to MDRE practices are mostly qualitative, a descriptive synthesis is made, where the results from the data extraction fields are presented in a tabular form in order to highlight similarities and differences between the study outcomes. If two or more studies discuss the same practice, or if two or more studies discuss techniques which share many common characteristics, they are grouped together to form a common practice.

In this study, we also intend to cover results from systematic literature reviews and other literature reviews about MDRE. Hence, results from primary studies

**Table 5** Data Extraction Form

Data Item	Value	RQ's
Researcher Name:		
Extraction Date:		
Article Title:		
Authors:		
Article Type:	Journal / Conference / Conference Proceeding	
Publication Year:		
Context Type:	Academia / Industry	RQ1.1
Research Methodology:	Experiment / Case Study / Survey / Action Research / Other	RQ1.3
Name of Practice / Model / Tool:		RQ1.1, RQ1.2
Type:	Practice / Model / Method / Technique / Tool	RQ1.1, RQ1.2
Purpose:		RQ1.2
Related Software Process Area(s):		RQ1.2
Validated in:	Academia / Industry	RQ1.3

**Table 6** Primary Search Results

	Database	Results
1	Engineering Village (Inspec, Compendex)	617
2	SCOPUS	571
3	ACM	254
4	IEEE	178
	Total	1620

may be repeated in the secondary studies. In order to avoid this issue, secondary studies such as systematic literature reviews are considered separately in the analysis. Two questions guide the analysis of these secondary studies:

- Does the secondary study cover primary studies which have been fully included in our final inclusion set? If so, the secondary study can be discarded and practices presented in it will not be counted again.
- Does the secondary study contribute other findings that are different from those found in the primary studies that are in our final inclusion set? If so, this may imply that the secondary study covers more than the papers in our final inclusion set. In this case, practices captured from the secondary study need to be checked against identified practices from the other papers. Duplicated activities would then be removed so as not to count them twice.

### 3.4 Execution and Results

The search terms in Table 3 were applied in the five selected databases to identify papers for the study. The databases were divided equally between two researchers, so each researcher independently applied the same three search strings on two databases (Engineering Village (Inspec + Compendex) + IEEE or SCOPUS + ACM). A total of 1620 publications were retrieved from the search, as presented in Table 6.

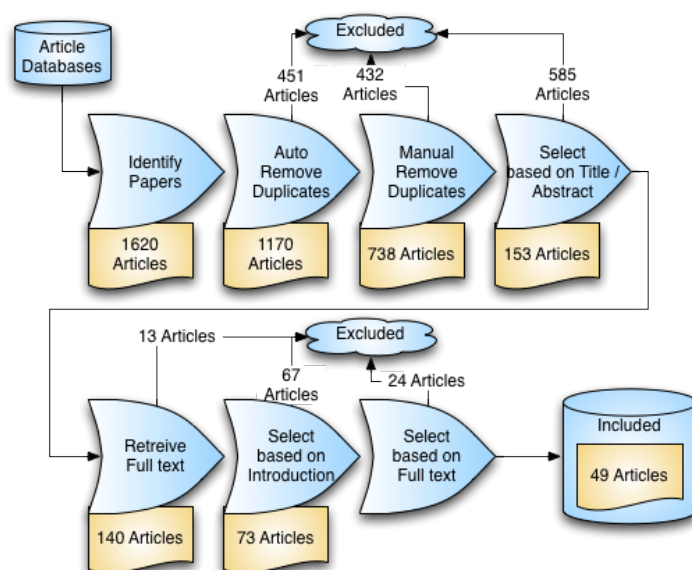

**Fig. 1** Study Selection Process

After checking for duplicates, 432 papers were removed and 738 papers remained. Of these, 585 papers were excluded by reading title and / or abstract. The full text for 140 of the the remaining 153 papers was then retrieved (we were unable to access the remaining 13) in order to read the introduction and full text. This resulted in 49 papers in the final inclusion set, from which data then was extracted according to the data extraction form. Although there were a significant number of articles found on MDRE, a large portion of them mainly discussed challenges and problems in the area without contributing any solutions. Hence, these were excluded. The remaining 49 studies in the final inclusion set are the studies that provide concrete answers on how to solve problems. Figure 1 illustrates the complete process and step-by-step result of the systematic review from the initial search to the final selection, and Table 8 lists the selected articles.

Each paper was read by one researcher, looking for practices and their motivation or empirical support. Each found practice was documented using the review form in Table 5. An example of an extracted practice is presented in Table 7, with the complete database of all extracted practices available on the project homepage <http://www.bth.se/tek/mdrepm.nsf>. The extracted and documented practices (in essence, the answer to RQ1) form the first input for constructing Uni-REPM.

### 3.4.1 General Characteristica

Of the 49 papers in the final inclusion set, 28 (58%) were published in 2006 or later. This phenomenon may be the result of a trend break where companies and researchers increased their attention to market-driven RE and conducted research

**Table 7** An Example of an Extracted Practice

Data Item	Value	RQ's
Researcher Name:	Loan	
Extraction Date:	2010-03-20	
Article Title:	On the creation of a reference framework for software product management: Validation and tool support	
Authors:	Van De Weerd	
Article Type:	Conference	
Publication Year:	2006	
Context Type:	Academia and Industry	RQ1.1
Research Methodology:	Other:Grounded Theory	RQ1.3
Name of Practice:	Consider internal and external stakeholders	RQ1.1, RQ1.2
Type:	Practice	RQ1.1, RQ1.2
Purpose:	Not Provided	RQ1.2
Related Software Process Area(s):	Requirements Process Management	RQ1.2
Validated in:	Industry, case study in 1 ERP vendor	RQ1.3

on it. This further motivates the need for Uni-REPM, as these modern practices are likely to not be represented in the current RE process assessment models.

The research methodology was with some difficulty classified into seven categories, as described below. The difficulties arose from the fact that the research methodology is often poorly described in the studied papers. Within parentheses we present the frequency of each of the categories.

- *Case Study* (13%) The study declares one or more research questions which are answered by conducting a case study.
- *Empirical Theory Construction* (21%) The study proposes new solutions based on empirical data.
- *Action Research* (35%) A reflective process is applied to improve the way a particular issue is addressed or a particular problem is solved.
- *Systematic Literature Review* (2%) A study performed to systematically synthesise relevant research to answer predefined research questions.
- *Literature Review* (10%) A review of several relevant studies conducted to answer predefined research questions.
- *Experiment* (4%) The study declares one or more research questions which are answered by conducting an experiment.
- *Rationalistic Theory Construction* (15%) The research proposes new theories based on the authors' experiences (without empirical data support).

An interesting observation can be discerned when we correlate the context with the methodology (Figure 2); empirical theory construction, action research, surveys, and case studies are the used methodologies in an industrial context, whereas experiments, systematic literature reviews, literature reviews, and rationalistic theory constructions are applied in academic contexts.

Quality assessment of the selected publications was conducted according to the protocol defined in the systematic review plan and is summarised in Table 9. As can be seen in Table 9, in most cases the solutions presented are described adequately and clearly. Moreover, in 19 of the 49 papers the findings can be generalised, and in a further 26 papers the findings can be partially generalised. One reason for the large number of partially generalisable results is that most of the studies use

Table 8 Final Inclusion Set

Id	Ref	Study Name
p1	[87]	Yeh, "REQUIREMENTS Engineering Support Technique (REQUEST) A Market Driven Requirements Management Process"
p2	[67]	Ramesh et al., "Towards Requirements Traceability Models"
p3	[66]	Potts, "Invented requirements and imagined customers: requirements engineering for off-the-shelf software"
p4	[58]	Maiden and Rugg, "ACRE: Selecting methods for requirements acquisition"
p5	[41]	Karlsson, Olsson, and Ryan, "Improved practical support for large-scale requirements prioritising"
p6	[69]	Regnell, Beremark, and Eklundh, "A market-driven requirements engineering process: results from an industrial process improvement programme"
p7	[50]	Lam, Jones, and Britton, "Technology Transfer for Reuse: A Management Model and Process Improvement Framework"
p8	[47]	Kilpi, "Improving software product management process: implementation of a product support system"
p9	[75]	Sawyer, Sommerville, and Kotonya, "Improving Market-Driven RE Processes"
p10	[13]	Carlshamre et al., "An industrial survey of requirements interdependencies in software product release planning"
p11	[12]	Carlshamre and Regnell, "Requirements lifecycle management and release planning in market-driven requirements engineering processes"
p12	[71]	Regnell et al., "An industrial case study on distributed prioritisation in market-driven requirements engineering for packaged software"
p13	[11]	Carlshamre, "Release Planning in Market-Driven Software Product Development: Provoking an Understanding"
p14	[30]	Grynberg and Goldin, "Product management in telecom industry using requirements management process"
p15	[17]	Daneva, "Lessons learnt from five years of experience in ERP requirements engineering"
p16	[72]	Rossi and Tuunanen, "A method and tool for wide audience requirements elicitation and rapid prototyping for mobile systems"
p17	[85]	Wieringa and Ebert, "RE?03: Practical requirements engineering solutions"
p18	[22]	Firesmith, "Prioritizing requirements"
p19	[21]	Ebert and De Man, "Requirements uncertainty: Influencing factor and concrete improvements"
p20	[54]	Lehtola, Kauppinen, and Kujala, "Linking the business view to requirements engineering: Long-term product planning by roadmapping"
p21	[38]	Jantunen and Smolander, "Towards Global Market-Driven Software Development Processes: An Industrial Case Study"
p22	[37]	Jantunen and Smolander, "Challenges of Knowledge and Collaboration in Roadmapping"
p23	[82]	Van De Weerd et al., "On the creation of a reference framework for software product management: Validation and tool support"
p24	[61]	Natt och Dag, Thelin, and Regnell, "An experiment on linguistic tool support for consolidation of requirements from multiple sources in market-driven product development"
p25	[6]	Berander and Jönsson, "Hierarchical Cumulative Voting (HCV)-Prioritization of Requirements In Hierarchies"
p26	[29]	Gorschek and Wohlin, "Requirements Abstraction Model"
p27	[20]	Ebert, "Understanding the product life cycle: four key requirements engineering techniques"
p28	[3]	AlBourae, Ruhe, and Moussavi, "Lightweight replanning of software product releases"
p29	[36]	Jansen and Brinkkemper, "Ten Misconceptions about Product Software Release Management explained using Update Cost/Value Functions"
p30	[44]	Karlsson and Regnell, "Introducing Tool Support for Retrospective Analysis of Release Planning Decisions"
p31	[53]	Lehtola, "Suitability of requirements prioritization methods for market-driven software product development"
p32	[43]	Karlsson et al., "Requirements engineering challenges in market-driven software development - An interview study with practitioners"
p33	[25]	Gorschek et al., "Industry evaluation of the requirements abstraction model"
p34	[45]	Karlsson et al., "Pair-wise comparisons versus planning game partitioning-experiments on requirements prioritisation techniques"
p35	[55]	Lehtola, Kauppinen, and Vahaniitty, "Strengthening the link between business decisions and RE: Long-term product planning in software product companies"
p36	[46]	Khurum, Aslam, and Gorschek, "A Method for Early Requirements Triage and Selection Utilizing Product Strategies"
p37	[5]	Barney, Aurum, and Wohlin, "A product management challenge: Creating software product value through requirements selection"
p38	[24]	Fricke, Gorschek, and Glinz, "Goal-oriented requirements communication in new product development"
p39	[2]	Akker et al., "Software Product Release Planning through Optimization and What-If Analysis"
p40	[33]	Herrmann and Daneva, "Requirements prioritization based on benefit and cost prediction: An agenda for future research"
p41	[60]	Mohamed and Wahba, "Value estimation for software product management"
p42	[70]	Regnell, Bertsson-Svensson, and Olsson, "Supporting Road-Mapping of Quality Requirements"
p43	[8]	Bertsson-Svensson, Gorschek, and Regnell, "Quality requirements in practice: An interview study in requirements engineering for embedded systems"
p44	[86]	Wilby, "Roadmap transformation: from obstacle to catalyst"
p45	[40]	Kabbedijk et al., "Customer involvement in requirements management: lessons from mass market software development"
p46	[19]	Dzamashvili-Fogelström, Svahnberg, and Gorschek, "Investigating Impact of Business Risk on Requirements Selection Decisions"
p47	[52]	Lehtola et al., "Linking business and requirements engineering: Is solution planning a missing activity in software product companies?"
p48	[23]	Fogelström et al., "The impact of agile principles on market-driven software product development"
p49	[68]	Ramesh & Jarke, "Towards Reference Models of Requirements Traceability"

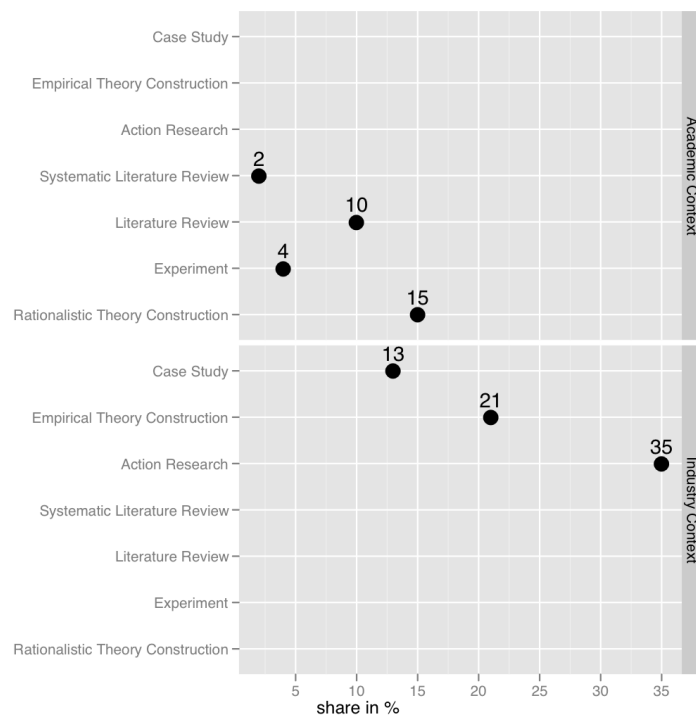

**Fig. 2** Research Methodology Distribution

**Table 9** Quality Assessment Results

Quality Assessment Criterion	Yes	Part.	No
Is the idea of the solution fully explained in the study?	41	7	1
Can the findings of the study be generalised?	19	26	4

qualitative research methodologies that do not focus on generalising the results [5]. However, many of the results can still be generalised given that the research participants are selected carefully and the research field and result are described in detail [58]. In summary, a majority of the studies in our final inclusion set demonstrate an acceptable quality, since they either fully or partially support both quality assessment criteria.

#### 4 Bespoke RE Practices

In order to ensure that bespoke practices are also covered in Uni-REPM, we conduct a traditional literature review of bespoke RE practices, the results of which will be merged with the findings from the systematic literature review on MDRE practices. The reason for performing a traditional literature review on bespoke

**Table 10** Practice Distribution according to Activity Area

Activity Area	Number of Practices
Requirements Management	55
Requirements Elicitation	17
Requirements Analysis	35
Release Planning	19
Requirements Validation	11

RE instead of a systematic literature review is that bespoke RE has existed and has been discussed for many years, and “good practices” have been presented in a number of books and assessment frameworks (see e.g. [4, 7, 88, 15, 81, 77, 27, 26]). The interchange and overlap between many of these sources are considerable, and thus extracting the body of knowledge from well known and recent literature sources are, we argue, sufficient for the construction of Uni-REPM.

We focus this literature review on the original REPM v1.0 [27], CMMI for development version 1.2 [15], and the TickIt implementation of ISO9001 [81]. All of these models are already industry validated, and together present an updated view of good RE practice. The literature review is performed by using the 68 practices in REPM v1.0 as a base, and then updated with newer practices in CMMI-DEV, and TickIt.

The literature review performed on CMMI-DEV focused on the two directly related process areas “Requirements Development” and “Requirements Management” as well as on the indirect area “Configuration Management”. The literature review on TickIt was performed by studying several sections such as “Requirements Management”, “Configuration Management” and the “Supplier” perspective.

Similar practices in the three sources were merged into new actions on a case by case basis. New actions were placed under the related Main Process Area (MPA)[27] and assigned a maturity level. Updated actions were kept at the same level and same Main Process Area but their names were modified to reflect the new information.

## 5 Answers to Research Questions

We are thus able to answer our research questions. We answer RQ1. *What are “good practices” for market-driven requirements engineering?* with the help of the three sub-questions.

**RQ1.1 What practices are explicitly suggested for market-driven RE?** A total of 163 practices are identified as being beneficial for market-driven RE. These practices include suggestions which aim to help companies that face challenges in MDRE, solutions for MDRE challenges proven or validated in the papers, activities mentioned in frameworks or process models for market-driven development, and solutions proposed to perform particular tasks in MDRE. After synthesis, where similar or duplicate practices were merged, 137 practices remained. These can be classified into different RE activity areas (from Aurum & Wohlin [4]), as presented in Table 10.

As can be seen, a large portion of the identified practices (40%) are proposed in the Requirements Management area while only a few (8%) are suggested for

Requirements Validation. This may be explained by the fact that requirements management is considered to contain many different tasks as opposed to the area of requirements validation where the tasks are not as easily divided. This may also imply that this area will need to be broken down in Uni-REPM so that problems in this area can be accurately and adequately discovered.

**RQ1.2 What practices can be extracted from existing techniques, tools, methods, and models for market-driven RE?** Through data extraction from the papers in the final inclusion set, we were able to discern 12 models and frameworks, 38 methods and techniques, and 10 tools supporting requirements activities in MDRE. After identifying models, frameworks, methods, techniques, and tools with similar purposes and grouping these together, and investigating the practices supported by the aforementioned artifacts, 16 practices were generalised. In all cases several artifacts supporting the same goal were generalised into a single practice. For example, the practice “Define and Maintain a Requirements Management Process” was derived from three process models and frameworks defining the procedure for managing requirements.

**RQ1.3 Which practices from RQ1.1 and RQ1.2 are justified for market-driven RE by empirical validation and/or rationale?** In order to answer this question, the 137 practices from RQ1.1 and the 16 practices from RQ1.2 were merged into a single set (153 practices) for inspection. In addition, a preliminary analysis was done to avoid duplication. Seven overlapping practices were removed, and the remaining 146 practices were further investigated to answer this research question. The main purpose of this systematic literature review is to identify “good practices” to be used as input for creating Uni-REPM in the next stage. “Good practices” mainly imply practices that are feasible and well motivated by empirical data and / or rationale. We thus analyse the 146 practices to determine their respective credibility. This is done by classifying them into Practice Categories, as described below.

- PC1. *Realised*. Practices that are realised in the form of concrete tools.
- PC2. *Validated Positive*. Practices that are validated in any context (including industrial settings, academic projects, or static validation), and where the validation context and explicit positive findings are presented.
- PC3. *Motivated Positive*. Practices with positive motivation supported by rationale using empirical data, professional knowledge or industrial experience.
- PC4. *Validated No Context*. Practices that are validated in any context (including industrial settings, academic projects, or static validation), but where no validation context is provided.
- PC5. *Validated Negative*. Practices that are validated in any context (including industrial settings, academic projects, or static validation), and where the validation context and explicit negative findings are presented.
- PC6. *Motivated Negative*. Practices mentioned with negative motivation (i.e. it is not beneficial to perform such practices).
- PC7. *Unmotivated*. Practices mentioned but with no further rationale provided.

Of these categories, PC1, PC2, and PC3 remain included, and the rest are filtered out. Although practices in PC1 are not motivated as strongly as through direct empirical evidence (e.g. as in PC2 and PC3), many of the tools are developed and sold commercially, which means that practices that do not positively support



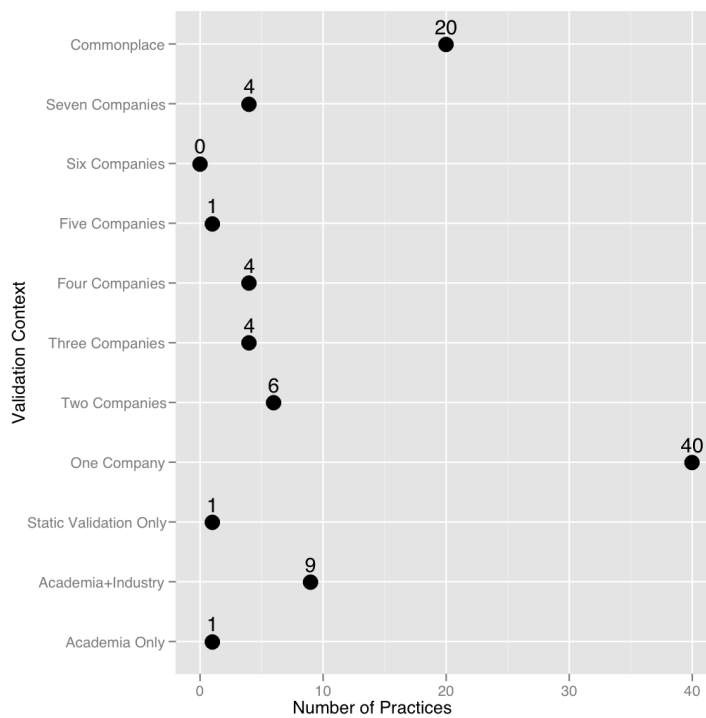

**Fig. 3** Validation Context

the requirements engineering process are likely to be culled or modified until they suit the users (i.e., industry).

Excluding PC4–PC7 results in 21 practices being pruned, and 125 practices remain for further analysis. We would like to point out that in some cases, the papers provide very little information about the data sources used. In these cases, the quality assessment was used. For example, if the paper states that empirical data is used to propose solutions but it is not described and no validation is conducted, the motivation for such solutions will not be considered. In the end, if no evidence for the credibility of a practice was found it was put into the “Unmotivated” category. In order to create a set of best practices, trust in the applicability (usefulness and usability) has to be taken into consideration [35].

The 125 market-driven practices are distributed as follows. Nine practices are realised, 90 practices are validated positive, and 26 practices are motivated. Of the 90 practices validated positive, 80 practices are validated in one or more industrial organisations, nine practices are checked against experts’ opinions in academia and later validated in industry, and one practice is validated in academia through experiments with PhD students and Master’s students. Further details about the validation context are presented in Figure 3.

The identified practices, frameworks, models, methods, techniques, and tools are summarised per paper in Table 11, where the discarded practices are also presented. The sources for the 16 additional practices distilled in RQ1.2 are presented

in Table 12. For example, paper p1 contributes the following practices (the rest are available at the project homepage <http://www.bth.se/tek/mdrepm.nsf>):

pr13 Monitor source of problem  
pr14 Collect/extract requirements and save to repository  
pr15 Assign tracking and control info  
pr16 Describe the environment from which the requirement originates (source of requirement)  
pr26 Validate the problem statement with the source to check that it is an accurate reflection of the intent  
pr33 Perform systematic requirements prioritization  
pr70 Describe problem scenario  
pr71 Categorize each problem statement (usability, availability, etc.) and correlate (duplicates, contradictions, etc.) with all other problem statements  
pr72 Analyze the problems in terms of market and competitive posture  
pr73 Assess the value  
pr109 Assign responsibilities for analysis and validation.  
mo9 Define and Maintain a Requirements Management Process  
to4 Consider Tool Support for Requirements Engineering

**RQ2. What are “good practices” for bespoke requirements engineering?**

In total, 16 new actions were added, primarily into the area Process Management (13 new actions), which reflects the increased attention this field has received in recent years. In addition, three actions in REPM v1.0 were updated to reflect current state-of-practice.

**RQ3. What trends can be seen with respect to “good practices” for market-driven and bespoke requirements engineering?** In order to answer this research question we plot the practices per year and process area, as shown in Figure 4. In this figure, the practices found for market-driven requirements engineering are presented in the bottom half of the figure, and those for bespoke in the top half. Since the practices for bespoke requirements engineering are found through a literature review of three sources, they are perforce collected in only three years (TickIt in 2001, REPM v1.3 in 2003, and CMMI-DEV in 2006). Moreover, we see that it is primarily REPM (and, in turn, its sources such as REGPG [77]) that contributes the practices for bespoke requirements engineering. It is interesting to note that this particular source, i.e. REGPG [77], also contributes practices for market-driven requirements engineering through paper p9 [75]. This provides further evidence that there are no watertight bulkheads between bespoke requirements engineering and market-driven requirements engineering; that is, practices used for one may also be of use for the other. Hence, synthetically creating such a dichotomy by focusing a process assessment model on just one context would not properly represent reality.

In Figure 4, a few trends may be seen. First, bespoke requirements engineering as defined by the used sources primarily focus on the hands-on practices of, e.g., elicitation, analysis and negotiation, requirements documentation, quality assurance, and process management. Conversely, market-driven requirements engineering research also emphasise areas such as release planning and organisational support.

A few seminal papers are noticeable in the research on market-driven research:

- Yeh in 1992 [87] that more or less started the research topic

**Table 11** Practices, Frameworks, Models, Methods, Techniques, and Tools per Article

Id	Practice (pr) / Model (mo) / Framework (fw) / Method (me) / Technique (te) / Tool (to)	Discarded
p1	pr13, pr14, pr15, pr16, pr26, pr33, pr70, pr71, pr72, pr73, pr109, mo8, to4	
p2	mo9	
p3	pr9, pr10, pr11	
p4	pr1, fw1, te1-te12	
p5	pr50, pr54, me4, te15, to1	
p6	pr29, pr33, pr65, pr81, pr114, mo5	
p7	pr49, pr75, pr76, pr77, pr78, pr79, pr80, pr133	
p8	mo7	
p9	pr5, pr6, pr7, pr8, pr18, pr19, pr20, pr21, pr22, pr33, pr55, pr56, pr57, pr58, pr59, pr82, pr83, pr84, pr117, pr118, pr119, pr120, pr121	
p10	pr50, pr51, te19	
p11	pr43, pr88, pr93, pr110	
p12		
p13	pr39, pr40, pr41, pr42, pr87	
p14	to9	
p15	pr12, pr23, pr24, pr49, pr61, pr86, pr105, pr122, pr123, pr124, pr125, pr126	pr134
p16	me2	
p17	to5, to6, to8, to10	
p18	pr33, pr62, pr63, pr64, pr65, pr66, pr67, pr130	
p19	pr27, pr95, pr111, pr131, me7	
p20		
p21	pr97, pr17	
p22	pr102, pr103, to7	
p23	pr14, pr25, pr33, pr36, pr37, pr38, pr39, pr61, pr96, pr97, pr127, pr128, fw2	pr62, pr63, pr64, pr67, pr130
p24	to3	
p25	te15, te16, te17	
p26	pr68, pr69, pr85, pr88, pr89, pr90, pr91, pr92, pr98, pr108, mo3	
p27	pr28, pr113, pr135, pr136, pr137	
p28	pr30, pr34, mo2, te15	pr43
p29	pr45, pr46, pr47	pr45, pr46
p30	me5, te15, te16, te18, to2	pr75, pr76, pr77, pr78, pr79, pr80, pr133
p31	pr33, pr74, te28, te33	
p32	pr81, pr115	
p33	pr60, pr85	
p34	pr67, pr129, te18, te28, te30	
p35	pr35, pr44, pr97, pr106, pr107	
p36	pr30, pr31, pr100, pr101, me6	
p37	pr32, pr67	
p38	pr53, pr116, mo6	
p39		
p40	pr66, mo4, te15, te16, te17, te18, te20, te21, te22, te23, te24, te25, te26, te27, te29, te31, te32	
p41		pr99
p42		
p43	pr48, te13	
p44	pr112, pr132, me3	
p45	pr2, pr3, pr4, pr33, pr52, mo1, me1	
p46	pr104	
p47	pr35, pr40, pr44, pr97, pr106, pr107, te14	
p48	pr134	
p49	mo9	

- Regnell et al.[69], Lam et al. [50], and Kilpi [47] in 1998 each contributed many of the practices
- Sawyer et al. [75] presents a literature review of market-driven requirements engineering practices up until 1999.
- No less than 11 papers in our study were published in 2006, where in particular v.d. Weerd [82] contributed a large number of practices, mostly in the process area release planning.

In addition, we may study trends concerning the different process areas. Specifically:

- Release planning has been researched throughout the entire time period with a moderate increase in attention from 2004 and onwards.
- Organisational support follows a similar trend, gaining more attention from 2006 and onwards.
- This trend is reversed for the process management area; from 2003 and onwards there is a moderate decrease in the amount of contributed practices.

**Table 12** Distilled Practices

Practice id	Sources
pr138	me3, te13, te14
pr139	mo5, mo7, mo8, fw2
pr140	to4-to10
pr141	mo2
pr142	mo9
pr143	mo6
pr144	mo1, fw1, me1, me2, te1-te8, te11, te12
pr145	te9, te10
pr146	mo3
pr147	me6
pr148	to3
pr149	te19
pr150	mo4, me7
pr151	te15-te18, te20, te21, te22, te24-te33
pr152	to1
pr153	me5, to2

- With the exception of Gorschek in 2006 [29], requirements documentation has not been an area of much research in market-driven research. Instead, the practices in this area are primarily contributed by the sources in bespoke requirements engineering.
- Very few practices are contributed by the sources in bespoke requirements engineering for the process areas organisational support and release planning. Given that there is a considerable amount of research in these areas, this further strengthens our motivation for creating an updated requirements engineering process assessment framework.

Finally, we would like to point towards a few neglected areas in market-driven requirements engineering research, namely quality assurance and requirements analysis and negotiation. While never forgotten by the research community, they are not extensively researched either. We would like to draw a parallel to another neglected area, i.e. documentation and requirements specification, and the contributions, e.g., by Gorschek [29]. While categorised as improvements to the requirements documentation, what these practices in fact do is to restructure the requirements document *such that* it facilitates early requirements triage (addressing the market-driven requirements engineering challenges of requirements overload [42]), classifies requirements into comparable levels of detail (facilitating prioritisation of the requirements), and improves communication between the marketing department and development units [42, 18]. We thus argue that there may be ways to address challenges in market-driven requirements engineering through indirect means, for example in the areas quality assurance and requirements analysis and negotiation, that may, e.g. support release planning [79].

## 6 Construction of Uni-REPM

In this section we present the construction of Uni-REPM based on the input of market-driven and bespoke practices from the previous sections. The aim of Uni-REPM is to serve as a universal light-weight model presenting the maturity of an RE process through sets of activities that together form a comprehensive and consistent requirements engineering process. Besides the assessment purpose,

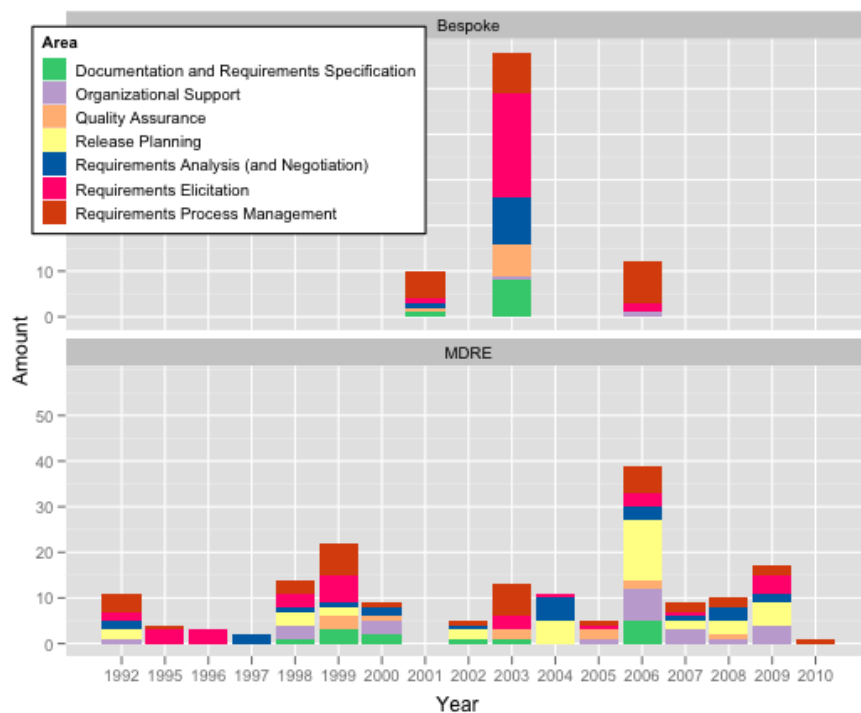

Fig. 4 Practices per Process Area and Year

Uni-REPM is also expected to function as a guideline giving organisations a recommended improvement path towards a better RE process from basic practices to an advanced level. The construction of Uni-REPM, and how the two literature studies are used as input, is illustrated in Figure 5. We remind the reader again of the three design objectives feasibility, universality, and light-weightedness, as introduced in Section 3. These govern not only which practices that should be included in the framework, but also the overall structure of the framework.

### 6.1 Overall Structure of Uni-REPM

Uni-REPM is structured in two views, a Process Area view, and a Maturity Level view. These serve two different purposes. The process area view is used to navigate the model and to quickly find practices that logically belong together, whereas the maturity level view describes sets of practices that constitute a consistent and coherent RE process, and where the practices in one level supports each other as well as the more advanced practices on the next level. This dual-view-approach is common for many prescriptive process improvement frameworks in requirements engineering such as REGPG [77], Wiegers [84], and Aurum & Wohlin [4], but also in more generic process improvement frameworks such as CMMI [15].

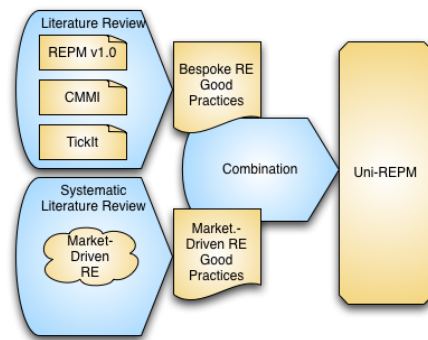

Fig. 5 Construction Process of Uni-REPM

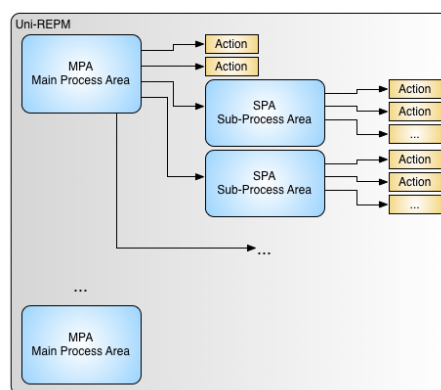

Fig. 6 Structure of Uni-REPM

### 6.1.1 Process Area View

The process area view is based on the original REPM [27] and REGPG [77] and is thus hierarchically constructed of Main Process Areas (MPA), consisting of Sub-Process Areas (SPA), and Actions. This is illustrated in Figure 6. This division enables a classification of individual practices into a hierarchy of related concepts, and enables an organisation to easily find practices that concern the same phenomenon, thus making the model easy to navigate.

Within the description of each action, there can be recommendations and supporting actions. Recommendations give practitioners suggestions on proven techniques or supporting tools for the practice. This information aims to help practitioners when implementing an action. Supporting actions consist of links to other actions which will benefit the practitioners if they are implemented together. In some cases, there are several ways to achieve the same goal but to different extents. Hence, actions that represent these different approaches can be grouped into an optional group, denoted by “OG”. For example “OG1.a1” points to the first option in the first optional group.

### 6.1.2 Maturity Level View

The intention of the Maturity Level View is to enable requirements engineering process improvement. The actions on a particular level constitute a consistent and coherent requirements engineering process and thus a company can focus on the actions on a particular maturity level that are not currently practiced, before moving on to actions on the next maturity level. The Maturity Level View is constructed by assigning a certain level to each action (from 1 to 3, corresponding to “Basic”, “Intermediate”, and “Advanced” level) depending on the difficulty to implement the action, how essential it is for the RE process, and dependencies between actions. This scale is inspired by REPM v1.0 [27], the Good Practice Guide [77], and Wiegers [84]. We have reduced the number of levels from five in REPM to three, in order to be able to distinguish a significant difference in the RE process between each level, and in order to conform with other frameworks such as the aforementioned REGPG [77]. This enables clearly identifiable and communicateable goals for each level, which facilitates for practitioners to understand what it means that their requirements engineering process is assessed to be on a particular maturity level. We would like to point out that the maturity level is only applicable to the RE process, and does not indicate anything concerning the overall maturity of the organisation as a whole. It should, however, be possible to compare two RE processes in terms of maturity using the results of an evaluation. The levels are defined as follows:

- *Level 1: Departure* The aim of this level is to achieve a rudimentary but repeatable RE process. The process is in this level defined and followed. Quality of requirements is managed because of relevant stakeholder involvement in elicitation, in-depth requirements analysis and pre-defined document standards. However, the process does not maintain any kind of communication among stakeholders and within the organization in term of strategies.
- *Level 2: Intermediate* In this level, the process is more rigorous because it involves several perspectives and is led by product strategies or goals. Roles and responsibilities for particular tasks are clearly defined and documented. Change requests are handled in a consistent manner throughout the project. Well-informed decisions about requirement selection can be made by analysing and prioritizing the requirements systematically. This process still stays in “present-state”, meaning that there is no activity performed to collect and analyse data or feedback for future improvement of the process.
- *Level 3: Destination* This level denotes the most mature process. The improvements in the process are shown in the advanced way of capturing requirements, ensuring their high quality, maintaining communications and a common understanding among different stakeholders and proactively assessing the decision making process. The process takes into account the “future-state” since it not only covers predefined and structured procedures but also pays adequate attention to future processes and work products (e.g. reusable materials, postmortem evaluation, etc.).

The assessment of which level an RE process resides on is fairly straightforward, the process resides on the highest possible level where all actions are performed. This can be studied for the whole RE process or for a single MPA. For optional groups, at least one action on the desired level or on higher levels has to be

performed. However, which level an organisation resides on is of lesser importance; it is far more important to investigate the actions that are not performed on the “next” maturity level and use this to instigate process improvement actions.

## 6.2 Model Contents

### 6.2.1 Structure

We propose seven main process areas for Uni-REPM, according to Loucopoulos [56], Sommerville & Sawyer [77], Kotonya & Sommerville [49], Wiegers [84], Gorschek et al. [27], and Aurum et al. [4]. We use a categorisation based on these sources as a basis in order to ensure that all primary RE activities are covered, as well as ensuring that the model is easy to understand and navigate since it is based on well known categories. The MPA’s are:

- *Organizational Support* Supporting activities given to the RE process from the surrounding organization.
- *Requirements Process Management* All the activities to manage and control requirements change as well as to ensure the organization of the process and coherence among team members.
- *Requirements Elicitation* Activities for discovering, understanding, anticipating and forecasting the needs and wants of the potential stakeholders in order to convey this information to the system developers.
- *Requirements Analysis (and Negotiation)* Activities to detect incomplete or incorrect requirements as well as to estimate necessary information for later activities (eg. risk, priorities, etc.).
- *Release Planning* Activities aiming to determine the optimal set of requirements for a certain release to be implemented at a defined or estimated time and cost to achieve a specific set of goals.
- *Documentation and Requirements Specification* Activities addressing how a company organises requirements and other knowledge gathered into consistent, accessible and reviewable documents.
- *Quality Assurance* Activities that involve checking the requirements against defined quality standards and the real needs of various stakeholders, ensuring that the documented requirements are complete, correct, consistent, and unambiguous.

These categories map to different sources as described in Table 13. In this table we list the main influencing sources of the MPA’s. For each source and MPA, we identify whether there is a particular section, chapter, or (in the case of process assessment frameworks) a practice area, that corresponds to the MPA in question. For reasons of brevity we do not list each of the chapter headings when multiple chapters are involved. As can be seen, in Uni-REPM we add categories for organisational support and release planning that are not explicitly covered previously. The need for both of these emerge from market-driven requirements engineering, where planning for several releases becomes more important [73, 79], and where the sheer volume of requirements [43, 25, 46] necessitates support not only within the project but also from the organisation and alignment with organisational strategies.



**Table 13** Mapping of MPA's to sources

	Organisational Support	Requirements Process Management	Requirements Elicitation	Requirements Analysis	Release Planning	Documentation and Specification	Quality Assurance
Loucopoulos [56]	Not explicitly covered	Partially chapter 2 (Processes in Requirements Engineering)	Chapter 3 (Requirements Elicitation)	Partially chapter 5 (Validation)	Not covered	Mentioned as a core activity, no dedicated chapter	Partially chapter 5 (Validation)
Sommerville & Sawyer [77]	Not explicitly covered	Chapter 9 (Requirements Management)	Chapter 4 (Requirements Elicitation)	Chapter 5 (Requirements Analysis & Negotiation)	Not covered	Chapters 3 & 6 (The Requirements Document, Describing Requirements)	Chapter 8 (Requirements Validation)
Kotonya & Sommerville [49]	Not explicitly covered	Chapters 2 & 5 (Requirements Engineering Processes, Requirements Management)	Chapter 3 (Requirements Elicitation and Analysis)	Chapter 3 (Requirements Elicitation and Analysis)	Not covered	Chapter 1.3 (The Requirements Document)	Chapter 4 (Requirements Validation)
Wiegiers [84]	Not explicitly covered	Chapters 16, 17, 18, 19	Chapters 1,4,6,7,8,11	Chapters 6,9,10,12,13	Not covered	Chapters 8, 9, 18	Chapter 14
Gorschek et al. [27]	Not covered	Covered (Management)	Covered (Requirements Elicitation)	Covered (Analysis and Negotiation)	Not covered	Not explicitly covered	Not explicitly covered
Aurum et al. [4]	Not covered	Not covered	Chapter 2 (Requirements Elicitation)	Chapters 4, 5, 6, 7	Partly chapter 12	Chapter 3 (Modeling and Specification of Requirements)	Chapter 8 (Quality Assurance)

### 6.2.2 Contents

Based on the systematic literature review on MDRE practices in Section 3 and the literature review on bespoke RE practices in Section 4, the actions in Uni-REPM are constructed by the following process:

- *Common* Practices common to market-driven and bespoke RE are obviously universally applicable and should hence be included in Uni-REPM.
- *Combined* Practices with similar goals, describing different ways to perform a certain task, or activities that support other practices, are merged into actions that combine all sources.
- *Different* Practices found only in either MDRE or in bespoke. These may be applicable in both cases even if this is not confirmed through empirical research. Connecting back to the Practice Categories in Section 5, PC1 and PC2 (re-validated and validated positive) are considered as essential to include regardless of whether they are universally applicable, whereas practices in PC3 (motivated positive) are included if they are claimed to be applicable for both bespoke and market-driven RE.

After deciding on a maturity level for each action, based on how difficult it is to implement, how essential it is for the RE process, and dependencies between actions, closely related actions are gathered into sub-process areas (SPAs), in order to increase understandability and navigability of Uni-REPM.

Table 14 Uni-REPM Summary

Id	Title	Level
<b>OS</b>	<b>Organizational Support</b>	
OS.a1	Assign Owner of Requirements Process	1
OS.a2	Create a Product-wide Glossary of Terms	1
<b>OS.RR</b>	<b>Roles and Responsibilities</b>	
OS.RR.a1	Define Roles and Responsibilities for Requirements Engineering Process	2
OS.RR.a2	Define Roles and Responsibilities for Release Planning Activities	2
OS.RR.a3	Define Roles and Responsibilities for Change Control	2
OS.RR.a4	Define Roles and Responsibilities for Product Management Organization	3
<b>OS.S</b>	<b>Strategic</b>	
OS.S.a1	Define Product Strategies	2
OS.S.a2	Define Product Roadmaps	2
OS.S.a3	Define Organizational Strategies	3
OS.S.a4	Communicate Strategies in Organization	3
<b>PM</b>	<b>Requirements Process Management</b>	
PM.a1	Introduce Tool Support for Requirements Engineering	1
PM.a2	Define and Maintain a Requirements Management Process	1
PM.a3	Train personnel in Requirements Management Process and Specialty (e.g.Prioritization)	2
PM.a4	Early connect portfolio considerations into requirements engineering process	3
PM.a5	Involve various perspectives in Requirement Engineering Process	2
<b>PM.CM</b>	<b>Configuration Management</b>	
PM.CM.a1	Manage Versions of Requirements	1
PM.CM.a2	Baseline Requirements	1
PM.CM.a3	Define a Process for Managing Change and Evolution	2
PM.CM.a4	Track change requests	2
<b>PM.RC</b>	<b>Requirements Communication</b>	
PM.RC.a1	Establish effective communication with requirements issuers	1
PM.RC.a2	Obtain common understanding of requirements among different involving teams	3
<b>PM.RT</b>	<b>Requirements Traceability Policy</b>	
PM.RT.a1	Uniquely Identify each Requirement	1
PM.RT.a2	Document Requirements' Source	1
PM.RT.a3	Document Requirements' Relation	2
PM.RT.a4	Document Impact of Requirement on Other Artifacts	2
PM.RT.a5	Define traceability policies	2
<b>RE</b>	<b>Requirements Elicitation</b>	
RE.SI	Stakeholder and Requirements Source Identification	
RE.SI.a1	Identify and Involve Relevant Stakeholders	1
RE.SI.a2	Distinguish between Customers, End-Users, and In-house Stakeholders	1
RE.SI.a3	Identify Other Requirements Sources	1
<b>RE.DC</b>	<b>Domain Consideration and Knowledge</b>	
RE.DC.a1	Consider System Domain Restrictions	1
RE.DC.a2	Consider System's Technical Infrastructure	1
RE.DC.a3	Consider Co-existing Business Processes	1
RE.DC.a4	Consider System's Business Process	1
RE.DC.a5	Consider System Boundaries	1
RE.DC.a6	Consider Sociopolitical Influences on Requirements Sources	2
<b>RE.EP</b>	<b>Elicitation Practices</b>	
RE.EP.a1	Adapt Elicitation Technique according to Situation	2
RE.EP.a2	Consider Quality Requirements	2
RE.EP.a3	Create Artifacts to Facilitate Elicitation and Analysis	2
RE.EP.a4	Let Business Concern/Product Strategies guide Focus of Elicitation Efforts	2
RE.EP.a5	Qualify and Quantify Quality Requirements	3
RE.EP.a6	Create Elicitation Channels for Requirements Sources	3
RE.EP.a7	Reuse Requirements	3
<b>RA</b>	<b>Requirements Analysis (and Negotiation)</b>	
RA.a1	Analyze for Missing, Double, Incomplete, Ambiguous Requirements	1
RA.a2	Perform Systematic Requirements Prioritization at In-project level	1
RA.a3	Perform Requirements Risk Analysis	2
RA.a4	Analyze for Requirements Functional Dependencies	2
RA.a5	Identify irrelevant requirements for early dismiss (in/out scope OR Triage)	2
RA.a6	Analyze Value-related Dependencies between Requirements	2
RA.a7	Perform refinement and abstraction of requirements	3
<b>RP</b>	<b>Release Planning</b>	
RP.a1	Synchronize Release Plan with Product Roadmap	2
RP.a2	Post Requirement Selection Evaluation	3
RP.a3	Plan multiple release at pre-defined interval	3
RP.a4	Involve different perspectives in release planning	2
<b>RP.S</b>	<b>Requirements Selection</b>	
RP.S.a1	Package Requirements into Releases	1
RP.S.a2	Perform Systematic Requirements Prioritization at Pre-project level based on value, cost, effort, etc.	2
RP.S.a3	Consider additional factors for prioritization	3
<b>DS</b>	<b>Documentation and Requirements Specification</b>	
DS.a1	Define Requirements Attributes	1
DS.a2	Establish Standardized Structure for SRS	1
DS.a3	Define Requirements States	2
DS.a4	Document Requirements Rationale	2
DS.a5	Record Rationale for Rejected Requirements	3
<b>DS.DD</b>	<b>Documentation Deliverables</b>	
DS.DD.a1	Define User Documentation Deliverables	2
DS.DD.a2	Define System Documentation Deliverables	2
DS.DD.a3	Define Management Documentation Deliverables	3
<b>QA</b>	<b>Quality Assurance</b>	
QA.a1	Use Checklist to Ensure Quality of Requirements	(OG1.a1) 1
QA.a2	Validate requirements with relevant stakeholders	1
QA.a3	Review Requirements	(OG1.a2) 2
QA.a4	Create Preliminary Artifacts for Quality Assurance	(OG1.a3) 3
QA.a5	Organize Inspections to Ensure Quality of Requirements	(OG1.a4) 3
QA.a6	Use System Model Paraphrasing for QA	(OG1.a5) 3

**Table 15** Example of an Uni-REPM action

OS.S.a1	Define Product Strategies	Level 2
	<p>Product Strategies can be defined by identifying where a company wants to go (direction of movement), how it will get there (means), what needs to be done (tactics), and why it will be successful (rationale). The direction of movement can be determined in terms of profit, growth, and market share. The means to reach the goals is by defining the customer targets, competitive targets, and differentiated advantage. The tactics cover product, pricing, promotion, distribution, and service. Documenting the rationale is important because it enables replicating the success of the product.</p> <p>The benefits of the product strategy are that it not only provides a long-term view of the product in the company but also drives the elicitation and analysis processes.</p> <p>The strategies should be documented in a central place and updated regularly.</p> <p>Supporting Action(s):</p> <ul style="list-style-type: none"> <li>– OS.RR.a5 Define Roles and Responsibilities for Product Management</li> </ul>	

An overview of the resulting Uni-REPM model is presented in Table 14, and an example of an action is presented in Table 15. A full description of all the actions, the Uni-REPM model itself, as well as checklists for conducting an Uni-REPM assessment can be found on the project homepage: <http://www.bth.se/tek/mdrepm.nsf>

### 6.3 Model Usage

Uni-REPM is intended to be used in the same way as REPM v1.0 [27], i.e. through a checklist. For each action, a question is posed, that can be answered either by “completed”, “incomplete”, or “satisfied/explained”. The “satisfied/explained” category ensures that the results of an evaluation can still be interpreted even when there are actions that are not applicable to a particular situation or organisation. In many ways, this can be seen as a gap between the model and real world usage. When evaluating Uni-REPM itself, the amount of actions that are listed as being “satisfied/explained” is an important indicator of how well the model actually performs and how light-weight it is.

A level is achieved when all actions on that level are “completed” or “satisfied/explained”. This may be studied for the entire RE process (thus using the full Uni-REPM), or for a particular MPA. An important analysis is to study the actions that are marked as incomplete on the level above the currently completed maturity level, as these indicate which activities should next be considered for process improvement efforts.

In Figure 7 we show an example of the results of a Uni-REPM evaluation. In this example we see that there are a number of actions that need to be completed before the project reaches the “departure” level, especially in the areas organisational support and in requirements analysis. We also see that the actions in the MPA Release Planning are, with one exception, not done on any level but are

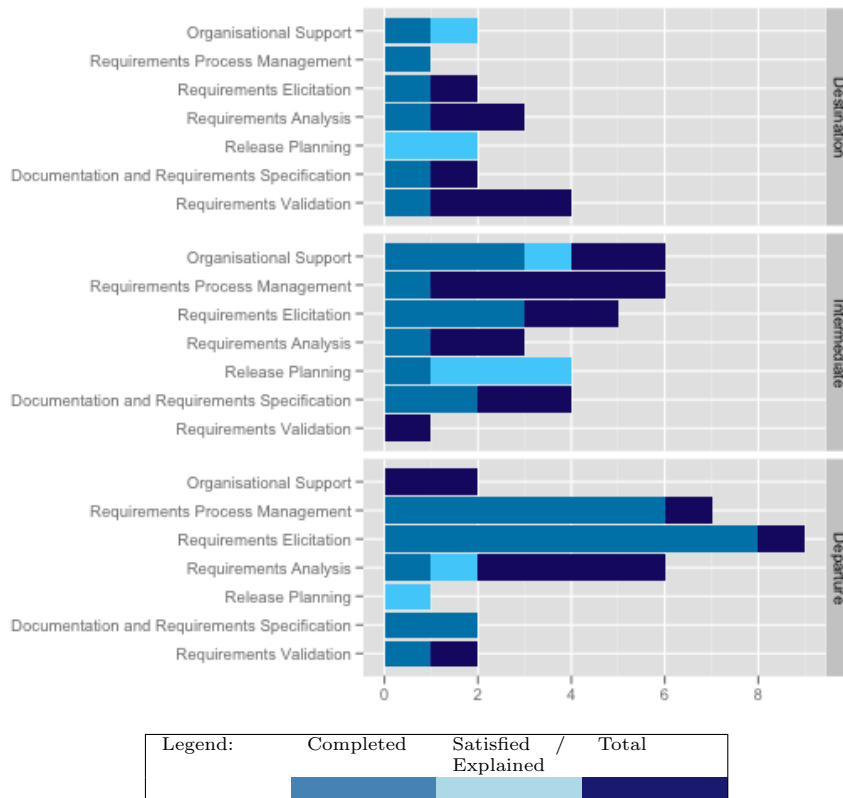

Fig. 7 Example of Uni-REPM Assessment Result

instead marked as satisfied/explained. In this particular case we may explain this with that the project is a bespoke project where release planning is not necessary.

## 7 Model Traceability

In Table 16 we present traceability information for the Uni-REPM practices. This information is presented so that the reader may trace the results of the systematic review and the literature review to the individual actions in Uni-REPM. Thus, we present the practices derived from the systematic literature review on market-driven practices in Section 3 (denoted *prnm*), the practices derived from the literature review on bespoke RE practices in Section 4 (denoted *bprnm*), and the papers from which these practices have been derived (denoted *pnn*). For the sake of simplicity, we extend the list of 49 papers from the systematic literature review with those used in the literature review, such that p50 refers to REPM v1.0 [27], p51 refers to CMMI-DEV [15], and p52 refers to TickIt 2001 [81]. Table 16 also lists the creation rationale for each Uni-REPM practice. The keys in this column are explained in Table 17.

**Table 16** Uni-REPM Traceability Information

ID	Rationale	Source MDRE Practice	Source Bespoke RE Practice	Article Source
<b>OS</b>				
OS.a1	APP	pr110		p11
OS.a2	APP		bpr23	p50
<b>OS.RR</b>				
OS.RR.a1	CON	pr75, pr77, pr109, pr110	bpr6	p1, p7, p11, p51
OS.RR.a2	ESS	pr113		p27
OS.RR.a3	APP	pr110, pr141		p11, p28
OS.RR.a4	ESS	pr103, pr111		p19, p22
<b>OS.S</b>				
OS.S.a1	ESS	pr80, pr100, pr104		p7, p36, p46
OS.S.a2	ESS	pr97, pr101, pr106, pr107, pr112		p21, p23, p35, p36, p44, p47
OS.S.a3	ESS	pr96		p23
OS.S.a4	ESS	pr102, pr137		p22, p27
<b>PM</b>				
PM.a1	CON	pr14, pr95, pr119, pr122, pr125, pr129, pr133, pr140	bpr25, bpr26	p1, p7, p9, p14, p15, p17, p19, p22, p23, p34, p50
PM.a2	CON	pr7, pr120, pr124, pr134, pr139	bpr12	p1, p6, p8, p9, p15, p23, p48, p51, p52
PM.a3	CON	pr5, pr132	bpr7	p9, p44, p51
PM.a4	ESS	pr137		p27
PM.a5	CON	pr28	bpr11	p27, p51, p52
<b>PM.CM</b>				
PM.CM.a1	COM	pr90	bpr76	p26, p50
PM.CM.a2	CON	pr83	bpr14	p9, p51
PM.CM.a3	CON	pr114, pr118, pr126	bpr10, bpr47, bpr48, bpr64, bpr72	p6, p9, p15, p50, p51, p52
PM.CM.a4	APP		bpr13	p51, p52
<b>PM.RC</b>				
PM.RC.a1	CON	pr3, pr26	bpr8	p45, p51, p52
PM.RC.a2	CON	pr74, pr105, pr115, pr143	bpr9	p15, p31, p32, p38, p52
<b>PM.RT</b>				
PM.RT.a1	COM	pr117	bpr38	p9, p50
PM.RT.a2	COM	pr69	bpr31	p26, p50
PM.RT.a3	GEN	pr42, pr149	bpr4, bpr44	p10, p13, p50, p51
PM.RT.a4	APP		bpr15	p51
PM.RT.a5	GEN	pr116, pr123, pr142	bpr39, bpr40, bpr56, bpr69	p2, p15, p38, p49, p50,
<b>RE</b>				
<b>RE.SI</b>				
RE.SI.a1	CON	pr8, pr127	bpr17, bpr19, bpr27, bpr28, bpr43	p9, p23, p50
RE.SI.a2	APP		bpr17, bpr19, bpr28, bpr43	p50
RE.SI.a3	APP	pr4, pr13, pr17		p1, p21, p45
<b>RE.DC</b>				
RE.DC.a1	COM	pr9, pr11, pr16, pr76, pr78	bpr41	p1, p3, p7, p50
RE.DC.a2	APP		bpr18	p50
RE.DC.a3	APP		bpr42	p50
RE.DC.a4	CON	pr84	bpr61	p9, p50
RE.DC.a5	APP		bpr45	p50
RE.DC.a6	APP		bpr60	p50
<b>RE.EP</b>				
RE.EP.a1	GEN	pr1, pr144	bpr1	p4, p16, p45, p51
RE.EP.a2	APP	pr48, pr95		p19, p43
RE.EP.a3	GEN	pr10, pr21, pr57, pr58, pr59, pr70, pr145	bpr20, bpr29, bpr35, bpr54, bpr62, bpr67, bpr74	p1, p3, p4, p9, p50
RE.EP.a4	ESS	pr6		p9
RE.EP.a5	COM	pr12	bpr34	p15, p50
RE.EP.a6	APP	pr2, pr115		p32, p45
RE.EP.a7	COM	pr49, pr61	bpr71	p7, p15, p23, p50
<b>RA</b>				
RA.a1	CON	pr52, pr53, pr71, pr72, pr148	bpr2, bpr3, bpr30, bpr57, bpr63	p1, p24, p38, p45, p50, p51, p52
RA.a2	GEN	pr55, pr63, pr64, pr65, pr66, pr130	bpr46	p9, p18, p50
RA.a3	APP		bpr49, bpr65, bpr66	p50
RA.a4	CON	pr48, pr50	bpr44	p5, p10, p43, p50
RA.a5	CON	pr60, pr147	bpr45	p33, p36, p50
RA.a6	APP	pr41, pr51		p10, p13
RA.a7	CON	pr54, pr68, pr146	bpr50	p5, p26, p50
<b>RP</b>				
RP.a1	ESS	pr31, pr32, pr36, pr44, pr138		p23, p35, p36, p37, p43, p44, p47
RP.a2	ESS	pr25, pr56		p9, p23
RP.a3	ESS	pr35, pr40, pr46, pr67		p13, p18, p29, p34, p35, p47
RP.a4	ESS	pr34, pr62		p18, p28
<b>RP.S</b>				
RP.S.a1	ESS	pr29, pr37, pr38, pr39, pr43, pr45, pr47, pr89		p6, p11, p23, p26, p29
RP.S.a2	ESS	pr30, pr33, pr55, pr65, pr73		p1, p6, p9, p18, p23, p28, p31, p36, p45
RP.S.a3	ESS	pr66		p18, p40
<b>DS</b>				
DS.a1	CON	pr69, pr81, pr85, pr91, pr92, pr93, pr98, pr108	bpr16	p6, p11, p26, p32, p33, p51
DS.a2	CON	pr19, pr82, pr128	bpr22, bpr32, bpr33, bpr52	p9, p23, p50
DS.a3	APP	pr88		p11, p26
DS.a4	COM	pr86	bpr51	p15, p50
DS.a5	COM	pr87, pr121	bpr73	p9, p13, p50
<b>DS.DD</b>				
DS.DD.a1	APP		bpr58	p50
DS.DD.a2	APP		bpr59	p50
DS.DD.a3	APP		bpr70	p50
<b>QA</b>				
QA.a1	COM	pr18, pr136	bpr21, bpr24	p9, p27, p50
QA.a2	CON	pr23, pr27	bpr5	p15, p19, p51
QA.a3	GEN	pr79, pr131, pr135	bpr55	p7, p19, p27, p50
QA.a4	GEN	pr22, pr99	bpr36, bpr37	p9, p42, p50
QA.a5	COM	pr20, pr24	bpr68	p9, p15, p50
QA.a6	APP		bpr75	p50

**Table 17** Rationale Explanations

Key	Explanation
COM	Common; these actions stem from practices that were common to both MDRE and Bespoke RE.
CON	Conforms; actions that stem from MDRE and Bespoke RE practices that conform to a common goal, even if the practices themselves may differ from each other.
GEN	Generalised; actions that stem from MDRE and Bespoke RE practices that describe different approaches to perform a certain task.
ESS	Essential; actions that stem from MDRE or Bespoke RE practices where the practice is realised and validated positive (PC1 or PC2 in Section 5).
APP	Applicable; actions that stem from MDRE or Bespoke RE practices where the practice is claimed to be applicable for both MDRE and Bespoke RE (PC3 in Section 5)

Summarising the different creation rationales, we see that there are 10 actions that are common (COM), 18 actions conforms to a common goal (CON), 7 actions are generalised from different ways of performing the same task (GEN), 15 actions are deemed essential to either MDRE or bespoke (ESS), and 20 actions are claimed to be applicable to both MDRE and bespoke (APP). In summary, of the 70 actions 35 actions are shared between bespoke and MDRE, and an additional 20 are claimed to be applicable to both. Thus, only 15 actions are considered unique to either bespoke or market-driven RE. A large majority of these are found in the areas strategic organisational support (OS.S) and release planning (RP). This further strenghtens the case that it makes sense to have a unified requirements engineering process assessment framework for both market-driven and bespoke requirements engineering.

## 8 Validity Threats

Validity threats to this study can be divided into two parts: Threats against the study that results in Uni-REPM, and validity threats for Uni-REPM itself. Below, we discuss each of these threats in turn.

### 8.1 Validity threats against this study

Publication bias is a common threat in systematic review in which positive findings tend to be published more than negative ones [48]. In order to lessen this threat, we have synthesised validation findings and conclusions from different studies in a controlled analysis process. We have also studied indirect evidence of working practices from, e.g. tools, methods, and frameworks (which can be seen as “grey literature” [48]). Thus, the credibility of one practice is judged based on an aggregation of several studies, rather than a single study. Moreover, it can be argued

that in order to elicit good practices, one is actively pursuing positive results, and hence (given the aforementioned careful process) the publication bias can be seen to work in our favour.

When more than one researcher is involved in a systematic review, selection and extraction consistency becomes a challenge. On one hand, it is desirable to use more than one researcher in order to confirm findings and interpretations, but when dividing the work between the researchers it becomes challenging to maintain consistent interpretations. To address this challenge, a two-stage process where each step is first piloted before conducting the full step was used. By performing pilot studies, the researchers are able to first evaluate and discuss the research instruments and the agreement level, after which the full step is executed with more aligned decisions. Although this strategy cannot ensure the consistency as absolutely as if all results are cross-checked by all researchers, it is an compromise between consistency and workload. To further ascertain a common interpretation, Cohen's Kappa coefficient [16] was calculated to be 0.78, which was considered an acceptable agreement level between the involved researchers.

We use two different research approaches for market-driven requirements engineering and bespoke requirements engineering. This results in a more careful approach when including market-driven practices into Uni-REPM, as opposed to bespoke practices. For market-driven practices, the validation status is used as a key indicator for inclusion or exclusion into Uni-REPM. For bespoke practices we do not require the same amount of published evidence. Instead, we base ourself on well established process assessment frameworks, and assume that the practices these advocate are proven to be of good quality. This validity threat also manifest itself in a different way: with more MDRE sources than bespoke RE sources, it may be argued that we can expect to see more MDRE practices than bespoke RE practices. However, studying Table 16, we find that MDRE sources and the bespoke RE sources are used more or less equally, and many practices are created as a result of a merge of MDRE and bespoke RE practices.

## 8.2 Validity threats against Uni-REPM

The first and most obvious threat against Uni-REPM is of course its validation status. Although based on empirically validated practices, it is nevertheless not yet validated as a complete assessment framework. In this study, we have strived to keep Uni-REPM light-weight and based on empirically validated good practices. Hence, we are reasonably convinced that it is applicable and useful as a requirements engineering process assessment framework. More complete validation, consisting of static validation with domain experts, and dynamic validation with the help of industry projects are planned and under way with, as yet, positive results [80]. To construct and conduct a proper validation scheme and to report from this is a considerable undertaking which we fear would detriment the study in this article, and above all would at least double the article's length. Thus, we choose to report on the validation of Uni-REPM in a separate article [80].

Another threat concerns the selection of practices that are included in Uni-REPM. As stated, the included practices are a result of an extensive systematic literature review and an intensive literature review, followed by a careful process of selecting empirically validated practices that are mentioned in more than one

source and in more than one context (bespoke as well as market-driven contexts). However, we have not considered matters such as, effect size or indirect connections between different practices. In other words, even if a certain practice is proven to be a good practice it may be only marginally good, especially compared to other practices. Moreover, there may be other practices that are related in a non-obvious way that strengthen, weaken, or completely supersede the effect of a particular practice. When creating Uni-REPM we have considered obvious connections between practices and we have somewhat tried to study the amount of available evidence, but we cannot guarantee, especially without further validation, whether there are any such effects in the included practices.

## 9 Conclusions

Throughout the years, several requirements engineering process assessment frameworks have been proposed and successfully used. Many of these frameworks were introduced in a time where market-driven requirements engineering was not commonly considered. More recent frameworks have focused solely on market-driven requirements engineering and have instead neglected bespoke requirements engineering. Finally, many of the proposed frameworks are several years old. This is an advantage, since if they have survived, the practices they prescribe are actually needed, but it is also evident that there is a mismatch between contemporary practice and the frameworks' prescribed practices. In other words; proposed practices are sometimes everyday practice today, current state-of-the-art research is not included in the assessment frameworks, and current industry practice is not completely covered in one single framework.

Hence, the goal of this article is to create a modern requirements engineering process assessment framework, Uni-REPM, that is based on state-of-the-art literature, and that covers both bespoke requirements engineering and market-driven requirements engineering.

To this end, three main research questions are studied, as discussed below.

RQ1. *What are “good practices” for market-driven requirements engineering?* In this article we present the results of a systematic literature review of market-driven requirements engineering practices. We focus on two sets of practices, those explicitly suggested for market-driven requirements engineering and those that can be generalised from supporting artifacts such as models, frameworks, techniques, etc. A total of 153 practices are found or generalised in our systematic literature review.

RQ2. *What are “good practices” for bespoke requirements engineering?* We conduct a literature review of bespoke requirements engineering practices using REPM 1.0 [27] as a base, complemented with CMMI-DEV and TickIt [15,81], in order to derive a modern set of bespoke requirements engineering practices. The review returned a set of 94 practices including 68 practices originally retrieved from REPM 1.0 with 3 updated and 16 additional practices.

RQ3. *What trends can be seen with respect to “good practices” for market-driven and bespoke requirements engineering?* Summarising the findings from RQ1 and RQ2, a few trends can be discerned. Release planning and organisational support has gained a slight increase in attention in recent years, whereas process



management is on the decline. Documentation, quality assurance, and requirements analysis appear to be neglected areas, and research in these areas may have significant effect on many challenges in market-driven requirements engineering.

The answers to these research questions are merged and distilled into Uni-REPM. This framework is structured in the same way as REPM 1.0 [27] into Main Process Areas, Sub-Process Areas, and Actions, where each action is placed on one out of three different maturity levels. This requirements engineering process assessment framework satisfies several key design objectives:

- It is *feasible*, since it is based on industry validated practices.
- It is *universal*, since it supports both bespoke and market-driven requirements engineering.
- It is *light-weight*, since it contains a relatively small set of practices, the general applicability of which is ensured through a number of steps.

For researchers, this provides a valuable synthesis of state-of-the-art and state-of-practice that may initiate new research on neglected topics or on validation of already existing topics. For industry practitioners, this enables a light-weight process assessment framework targeted at the requirements engineering process, that is usable without determining beforehand whether the company needs an assessment framework for bespoke or market-driven requirements engineering, or a hybrid of the two. The suggested practices in the framework constitute practices that have been proposed by the scientific community, sufficiently motivated, and empirically validated, which ensures feasibility of suggested process improvements.

## 9.1 Future Work

Even though Uni-REPM is based on validated practices, the framework itself needs to be validated in several steps, as outlined below:

1. Static validation with the help of domain experts to ensure that Uni-REPM is understandable and that it has a sufficiently complete coverage of practices.
2. Dynamic validation in a set of industry projects to ensure the applicability of Uni-REPM.
3. Tool support to support practitioners in assessing their requirements engineering processes with the help of Uni-REPM.

Work on these items are already well underway. For more information, please see the project's homepage: <http://www.bth.se/tek/mdrepm.nsf>

## References

1. Adam, S., Doerr, J., Eisenbarth, M.: Lessons Learned from Best Practice-Oriented Process Improvement in Requirements Engineering: A Glance into Current Industrial RE Application. In: Fourth International Workshop on Requirements Engineering Education and Training (REET), pp. 1–5. IEEE Computer Society, Los Alamitos CA (2009)
2. van den Akker, M., Brinkkemper, S., Diepen, G., Versendaal, J.: Software product release planning through optimization and what-if analysis. *Information and Software Technology* **50**(1-2), 101–111 (2008)

3. AlBourae, T., Ruhe, G., Moussavi, M.: Lightweight replanning of software product releases. In: Proceedings of the First International Workshop on Software Product Management, IWSPM06, pp. 27–34. IEEE Computer Society, Los Alamitos CA (2006)
4. Aurum, A., Wohlin, C. (eds.): Engineering and Managing Software Requirements. Springer Verlag, Berlin Germany (2005)
5. Barney, S., Aurum, A., Wohlin, C.: A product management challenge: Creating software product value through requirements selection. *Journal of Systems Architecture* **54**(6), 576–593 (2008)
6. Berander, P., Jönsson, P.: Hierarchical cumulative voting (hcv)–prioritization of requirements in hierarchies. *International Journal of Software Engineering and Knowledge Engineering* **16**(6), 819–849 (2006)
7. Berenbach, B., Paulish, D., Kazmeier, J., Rudorfer, A.: Software & Systems Requirements Engineering: In Practice. McGraw-Hill, Inc., New York, NY, USA (2009)
8. Berntsson Svensson, R., Gorschek, T., Regnell, B.: Quality requirements in practice: An interview study in requirements engineering for embedded systems. In: Proceedings of the 2009 Workshop on Requirements Engineering: Foundation for Software Quality (REFSQ'09), vol. LNCS5512, pp. 218–232. Springer Verlag, Berlin Germany (2009)
9. Boehm, B., Papaccio, P.: Understanding and controlling software costs. *IEEE Transactions on Software Engineering* **14**(10), 1462–1477 (1988)
10. Brereton, P., Kitchenham, B., Budgen, D., Turner, M., Khalil, M.: Lessons from applying the systematic literature review process within the software engineering domain. *Journal of Systems and Software* **80**(4), 571–583 (2007)
11. Carlshamre, P.: Release planning in market-driven software product development: Provoking an understanding. *Requirements Engineering* **7**(3), 139–51 (2002)
12. Carlshamre, P., Regnell, B.: Requirements lifecycle management and release planning in market-driven requirements engineering processes. In: Proceedings of the 11th International Workshop on Database and Expert Systems Applications, pp. 961–965. IEEE Comput. Soc, Los Alamitos, CA, USA (2000)
13. Carlshamre, P., Sandahl, K., Lindvall, M., Regnell, B., Natt och Dag, J.: An industrial survey of requirements interdependencies in software product release planning. In: Proceedings of the Fifth IEEE International Symposium on Requirements Engineering, pp. 84–91. IEEE Comput. Soc, Los Alamitos, CA, USA (2000)
14. Carmel, E., Becker, S.: A process model for packaged software development. *IEEE Transactions on Engineering Management* **42**(1), 50–61 (1995)
15. CMMI-Dev: Cmmi for development version 1.2 cmmi-dev v1.2. Tech. Rep. CMU/SEI-2006-TR-008, Software Engineering Institute, Carnegie Mellon University (2006)
16. Cohen, J.: A coefficient of agreement for nominal scales. *Educational and psychological measurement* **20**(1), 37–47 (1960)
17. Daneva, M.: Lessons learnt from five years of experience in erp requirements engineering. In: Proceedings of the 11th IEEE International Requirements Engineering Conference, pp. 45–54. IEEE Comput. Soc, Los Alamitos, CA, USA (2003)
18. Davis, A.: Just Enough Requirements Management: Where Software Development Meets Marketing. Dorset House Publishing Co., Inc. New York, NY, USA (2005)
19. Dzamashvili-Fogelström, N., Svahnberg, M., Gorschek, T.: Investigating impact of business risk on requirements selection decisions. In: Proceedings of the 35th Euromicro Conference on Software Engineering and Advanced Applications, pp. 217–223. IEEE Computer Society Press, Los Alamitos CA (2009)
20. Ebert, C.: Understanding the product life cycle: four key requirements engineering techniques. *IEEE Software* **23**(3), 19–25 (2006)
21. Ebert, C., De Man, J.: Requirements uncertainty: Influencing factor and concrete improvements. In: Proceedings of the 27th International Conference on Software Engineering, ICSE05, pp. 553–560. ACM Press, New York NY (2005)
22. Firesmith, D.: Prioritizing requirements. *Journal of Object Technology* **3**(8), 35–47 (2004)
23. Fogelström, N.D., Gorschek, T., Svahnberg, M., Olsson, P.: The impact of agile principles on market-driven software product development. *Journal of Software Maintenance and Evolution* **22**(1), 53–80 (2010)
24. Fricker, S., Gorschek, T., Glinz, M.: Goal-oriented requirements communication in new product development. In: Proceedings of the Second International Workshop on Software Product Management. IEEE Computer Society, Los Alamitos CA (2008)
25. Gorschek, T., Garre, P., Larsson, S., Wohlin, C.: Industry evaluation of the requirements abstraction model. *Requirements Engineering* **12**(3), 163–190 (2007)

26. Gorschek, T., Gomes, A., Pettersson, A., Torkar, R.: Introduction of a process maturity model for market-driven product management and requirements engineering. *Journal of Software Maintenance and Evolution: Research and Practice* (2011)
27. Gorschek, T., Svahnberg, M., Tejle, K.: Introduction and application of a lightweight requirements engineering process. In: *Proceedings of the Ninth International Workshop on Requirements Engineering: Foundation for Software Quality (RESFQ 2003)* (2003)
28. Gorschek, T., Wohlin, C.: Packaging software process improvement issues: a method and a case study. *Software: Practice and Experience* **34**(14), 1311–1344 (2004)
29. Gorschek, T., Wohlin, C.: Requirements abstraction model. *Requirements Engineering* **11**, 79–101 (2006)
30. Grynberg, A., Goldin, L.: Product management in telecom industry-using requirements management process. In: *Proceedings of the IEEE International Conference on Software - Science, Technology and Engineering (SwSTE'03)*, pp. 63–70. IEEE Comput. Soc, Los Alamitos, CA, USA (2003)
31. Hall, T., Beecham, S., Rainer, A.: Requirements problems in twelve software companies: an empirical analysis. *Software, IEE Proceedings* **149**(5), 153–160 (2002)
32. Hannay, J., Sjöberg, D., Dybå, T.: A systematic review of theory use in software engineering experiments. *IEEE Transactions on Software Engineering* pp. 87–107 (2007)
33. Herrmann, A., Daneva, M.: Requirements prioritization based on benefit and cost prediction: An agenda for future research. In: *Proceedings of the 16th IEEE International Requirements Engineering Conference, RE08*, pp. 125–134. IEEE Computer Society, Los Alamitos CA (2008)
34. Hutchings, A., Knox, S.: Creating products customers demand. *Communications of the ACM* **38**(5), 72–80 (1995)
35. Ivarsson, M., Gorschek, T.: A method for evaluating rigor and industrial relevance of technology evaluations. *Empirical Software Engineering* **16**(3), 365–395 (2010)
36. Jansen, S., Brinkkemper, S.: Ten misconceptions about product software release management explained using update cost/value functions. In: *Proceedings of the First International Workshop on Software Product Management, IWSPM06*, pp. 44–50 (2006)
37. Jantunen, S., Smolander, K.: Challenges of knowledge and collaboration in roadmapping. In: *Proceedings of the First International Workshop on Software Product Management, IWSPM06*, pp. 19–26 (2006)
38. Jantunen, S., Smolander, K.: Towards global market-driven software development processes: An industrial case study. In: *Proceedings of the 2006 international workshop on Global software development for the practitioner*, pp. 94–100. ACM, New York NY (2006)
39. Juristo, N., Moreno, A., Silva, A.: Is the European industry moving toward solving requirements engineering problems? *IEEE Software* **19**(6), 70–77 (2002)
40. Kabbedijk, J., Brinkkemper, S., Jansen, S., van der Veldt, B.: Customer involvement in requirements management: lessons from mass market software development. In: *Proceedings of the 17th IEEE International Requirements Engineering Conference. RE09*, pp. 281–6. IEEE Computer Society, Los Alamitos CA (2009)
41. Karlsson, J., Olsson, S., Ryan, K.: Improved practical support for large-scale requirements prioritising. *Requirements Engineering* **2**(1), 51–60 (1997)
42. Karlsson, L., Dahlstedt, Å., Natt och Dag, J., Regnell, B., Persson, A.: Challenges in market-driven requirements engineering – an industrial interview study. In: *Proceedings of the Eight International Workshop on Requirements Engineering: Foundation for Software Quality (REFSQ)*, pp. 37–49. Essen, Germany (2002)
43. Karlsson, L., Dahlstedt, Å., Regnell, B., Natt och Dag, J., Persson, A.: Requirements engineering challenges in market-driven software development - an interview study with practitioners. *Information and Software Technology* **49**(6), 588–604 (2007)
44. Karlsson, L., Regnell, B.: Introducing tool support for retrospective analysis of release planning decisions. In: *Proceedings of the 7th International Conference on Product-Focused Software Process Improvement (PROFES 2006)*, Lecture Notes in Computer Science LNCS 4034, pp. 19–33. Springer Verlag, Berlin Germany (2006)
45. Karlsson, L., Thelin, T., Regnell, B., Berander, P., Wohlin, C.: Pair-wise comparisons versus planning game partitioning—experiments on requirements prioritisation techniques. *Empirical Software Engineering* **12**(1), 3–33 (2007)
46. Khurum, M., Aslam, K., Gorschek, T.: A method for early requirements triage and selection utilizing product strategies. In: *Proceedings of the 14th Asia-Pacific Software Engineering Conference*, pp. 97–104. IEEE Computer Society Press, Los Alamitos CA (2007)

47. Kilpi, T.: Improving software product management process: implementation of a product support system. In: Proceedings of the 31st Hawaii International Conference on System Sciences, vol. vol.6, pp. 3–12. IEEE Comput. Soc, Los Alamitos, CA, USA (1998)
48. Kitchenham, B., Charters, S.: Guidelines for performing systematic literature reviews in software engineering, version 2.3. Tech. Rep. EBSE Technical Report EBSE-2007-01, Keele University (2007)
49. Kotonya, G., Sommerville, I.: Requirements Engineering — Processes and Techniques. John Wiley & Sons, Chichester UK (1998)
50. Lam, W., Jones, S., Britton, C.: Technology transfer for reuse: A management model and process improvement framework. In: Proceedings of the 3rd International Conference on Requirements Engineering, ICRE, pp. 233–240. IEEE Comp Soc, Los Alamitos CA (1998)
51. Leffingwell, D.: Calculating your return on investment from more effective requirements management. *American Programmer* **10**(4) (1997)
52. Lehtola, K., Kauppinen, M., Vahaniitty, J., Komssi, M.: Linking business and requirements engineering: Is solution planning a missing activity in software product companies? *Requirements Engineering* **14**(2), 113–128 (2009)
53. Lehtola, L.: Suitability of requirements prioritization methods for market-driven software product development. *Software process improvement and practice* **11**(1), 7–19 (2006)
54. Lehtola, L., Kauppinen, M., Kujala, S.: Linking the business view to requirements engineering: Long-term product planning by roadmapping. In: Proceedings of the 13th IEEE International Conference on Requirements Engineering, pp. 439–443. IEEE Computer Society, Los Alamitos CA (2005)
55. Lehtola, L., Kauppinen, M., Vahaniitty, J.: Strengthening the link between business decisions and re: Long-term product planning in software product companies. In: Proceedings of the 15th IEEE International Requirements Engineering Conference, RE07, pp. 153–162 (2007)
56. Loucopoulos, P., Karakostas, V.: System requirements engineering. *International Software Engineering Series*. McGraw-Hill Book Co (1995)
57. Lubars, M., Potts, C., Richter, C.: A review of the state of the practice in requirements modeling. In: Proceedings of the IEEE International Symposium on Requirements Engineering, pp. 2–14. IEEE Computer Society, Los Alamitos CA (1992)
58. Maiden, N.A.M., Rugg, G.: Acre: Selecting methods for requirements acquisition. *Software Engineering Journal* **11**(3), 183–192 (1996)
59. Mathiassen, L., Saarinen, T., Tuunanen, T., Rossi, M.: A contingency model for requirements development. *Journal of the Association for Information Systems* **8**(11), 569–597 (2007)
60. Mohamed, S.I., Wahba, A.M.: Value estimation for software product management. In: Proceedings of the 2008 IEEE International Conference on Industrial Engineering and Engineering Management, IEEM2008, pp. 2196–2200. IEEE Computer Society, Los Alamitos CA (2008)
61. Natt och Dag, J., Thelin, T., Regnell, B.: An experiment on linguistic tool support for consolidation of requirements from multiple sources in market-driven product development. *Empirical Software Engineering* **11**(2), 303–329 (2006)
62. Neill, C., Laplante, P.: Requirements engineering: The state of the practice. *IEEE Software* **20**(6), 40–45 (2003)
63. Niazi, M., Cox, K., Verner, J.: An empirical study identifying high perceived value requirements engineering practices. In: A. Nilsson, R. Gustas, W. Wojtkowski, W. Wojtkowski, S. Wrycza, J. Zupancic (eds.) *Advances in Information Systems Development*, pp. 731–743. Springer Verlag, Berlin Germany (2006)
64. Nikula, U., Sajaniemi, J., Kälviäinen, H.: A state-of-practice survey on requirements engineering in small-and-medium-sized enterprises. Tech. rep., Lappeenranta University of Technology (2000)
65. Pettersson, F., Ivarsson, M., Gorschek, T., Ohman, P.: A practitioner’s guide to light weight software process assessment and improvement planning. *Journal of Systems and Software* **81**(6), 972–995 (2008)
66. Potts, C.: Invented requirements and imagined customers: requirements engineering for off-the-shelf software. In: Proceedings of the Second IEEE International Symposium on Requirements Engineering, pp. 128–128. IEEE Computer Society, Los Alamitos CA (1995)
67. Ramesh, B., Dwiggin, D., DeVries, G., Edwards, M.: Towards requirements traceability models. In: Proceedings of the 1995 International Symposium and Workshop on Systems Engineering of Computer Based Systems, pp. 229–232. IEEE Computer Society, Los Alamitos CA (1995)

68. Ramesh, B., Jarke, M.: Toward reference models of requirements traceability. *IEEE Trans. Software Eng.* **27**(1), 58–93 (2001)
69. Regnell, B., Beremark, P., Eklundh, O.: A market-driven requirements engineering process: results from an industrial process improvement programme. *Requirements Engineering* **3**, 121–129 (1998)
70. Regnell, B., Berntsson-Svensson, R., Olsson, T.: Supporting road-mapping of quality requirements. *IEEE Software* **25**(2), 42–47 (2008)
71. Regnell, B., Höst, M., Natt och Dag, J., Beremark, P., Hjelm, T.: An industrial case study on distributed prioritisation in market-driven requirements engineering for packaged software. *Requirements Engineering* **6**(1), 51–62 (2001)
72. Rossi, M., Tuunanen, T.: A method and tool for wide audience requirements elicitation and rapid prototyping for mobile systems. In: *Proceedings of Conceptual Modeling for Advanced Application Domains*, vol. LNCS3289, pp. 629–640. Springer Verlag, Berlin, Germany (2004)
73. Ruhe, G., Saliu, M.O.: The art and science of software release planning. *IEEE Software* **22**(6), 47–53 (2005)
74. Sawyer, P.: Packaged software: challenges for RE. In: *Proceedings of the 6th International Workshop on Requirements Engineering: Foundation for Software Quality* (2000)
75. Sawyer, P., Sommerville, I., Kotonya, G.: Improving market-driven re processes. In: *Proceedings of the International Conference on Product Focused Software Process Improvement (PROFES'99)*, pp. 222–236. VTT, Oulo, Finland (1999)
76. Sommerville, I.: *Software Engineering*, 7th Edition. Addison-Wesley, Harlow UK (2004)
77. Sommerville, I., Sawyer, P.: *Requirements engineering: a good practice guide*. John Wiley & Sons Inc (1997)
78. Spice: Spice: Software process improvement and capability determination. <http://www.sqi.gu.edu.au/spice/> (2011)
79. Svahnberg, M., Gorschek, T., Feldt, R., Torkar, R., Saleem, S.B., Shafique, M.U.: A systematic review on strategic release planning models. *Information and Software Technology* **52**(3), 237 – 248 (2010)
80. Svahnberg, M., Gorschek, T., Nguyen, T.T.L., Nguyen, M.: Uni-repm: validated and improved. *Requirements Engineering* **18**(1), 85–103 (2013). DOI 10.1007/s00766-012-0148-1. URL <http://dx.doi.org/10.1007/s00766-012-0148-1>
81. TickIt: The tickit guide – using iso9001:2000 for software quality management system, construction, certification and continual improvement. Tech. Rep. Issue 5.0, British Standards Institute (2001)
82. Van De Weerd, I., Brinkkemper, S., Nieuwenhuis, R., Versendaal, J., Bijlsma, L.: On the creation of a reference framework for software product management: Validation and tool support. In: *Proceedings of the First International Workshop on Software Product Management, IWSPM06*, pp. 3–11. IEEE Computer Society, Los Alamitos CA (2006)
83. Webster, J., Watson, R.: Analyzing the past to prepare for the future: Writing a literature review. *MIS Quarterly* **26**(2) (2002)
84. Wiegers, K.: *Software Requirements*, 2 edn. Microsoft Press, Redmond, WA, USA (2003)
85. Wieringa, R., Ebert, C.: Re'03: Practical requirements engineering solutions. *IEEE Software* **21**(2), 16–17 (2004)
86. Wilby, D.: Roadmap transformation: from obstacle to catalyst. In: *Proceedings of the 2009 Agile Conference (Agile 2009)*, pp. 229–34. IEEE, Los Alamitos CA (2009)
87. Yeh, A.C.: Requirements engineering support technique (request) a market driven requirements management process. In: *Proceedings of the Second Symposium on Assessment of Quality Software Development Tools*, pp. 211–223. IEEE Computer Society, Los Alamitos CA (1992)
88. Young, R.: *The requirements engineering handbook*. Artech House (2003)