



Universal mobile electrochemical detector designed for use in resource-limited applications

Citation

Nemiroski, A., D. C. Christodouleas, J. W. Hennek, A. A. Kumar, E. J. Maxwell, M. T. Fernandez-Abedul, and G. M. Whitesides. 2014. "Universal Mobile Electrochemical Detector Designed for Use in Resource-Limited Applications." *Proceedings of the National Academy of Sciences* 111 (33) (August 4): 11984–11989. doi:10.1073/pnas.1405679111.

Published Version

doi:10.1073/pnas.1405679111

Permanent link

<http://nrs.harvard.edu/urn-3:HUL.InstRepos:16920716>

Terms of Use

This article was downloaded from Harvard University's DASH repository, and is made available under the terms and conditions applicable to Open Access Policy Articles, as set forth at <http://nrs.harvard.edu/urn-3:HUL.InstRepos:dash.current.terms-of-use#OAP>

Share Your Story

The Harvard community has made this article openly available.
Please share how this access benefits you. [Submit a story](#).

[Accessibility](#)

A Universal Mobile Electrochemical Detector Designed for Use in Resource-Limited Applications

Alex Nemiroski^a, Dionysios C. Christodouleas^a, Jonathan W. Hennek^a, Ashok A. Kumar^b, E. Jane Maxwell^a, Maria Teresa Fernández-Abedul^c, and George M. Whitesides^{a,d,e}

^a Department of Chemistry & Chemical Biology, Harvard University, Cambridge, MA 02138

^b School of Engineering and Applied Science, Harvard University, Cambridge, MA 02138

^c Departamento de Química Física y Analítica, Universidad de Oviedo, Asturias, Spain

^d Wyss Institute for Biologically Inspired Engineering, Harvard University, Cambridge, MA 02138 USA

^e The Kavli Insitute for Bionano Science, Harvard University, Cambridge, MA 02138 USA

Corresponding author:

George M. Whitesides
230 Mallinkrodt Bldg.
Harvard University
12 Oxford St.
Cambridge, MA 02138
(617) 495-9430
gwhitesides@gmwgroup.harvard.edu

Classification:

Physical Sciences: Engineering

Keywords:

Electrochemistry, mHealth, telemedicine, point-of-care diagnostics, potentiostat

ABSTRACT

This article describes an inexpensive, hand-held device that couples the most common forms of electrochemical analysis directly to “the cloud” using any mobile phone, for use in resource-limited settings. The device is designed to operate with a wide range of electrode formats, can perform on-board mixing of samples by vibration, and transmits data over voice using audio—an approach that guarantees broad compatibility with any available mobile phone (from low-end phones to smartphones) or cellular network (2, 3, or 4G). The electrochemical methods that we demonstrate enable quantitative, broadly applicable, and inexpensive sensing with flexibility based on a wide variety of important electroanalytical techniques (chronoamperometry, cyclic voltammetry, differential pulse voltammetry, square-wave voltammetry, and potentiometry), each with different uses. Four applications demonstrate the analytical performance of the device: these involve the detection of i) glucose in blood for personal health, ii) trace heavy metals—lead, cadmium, and zinc—in water for in-field environmental monitoring, iii) sodium in urine for clinical analysis, and iv) a malarial antigen, *Plasmodium falciparum* histidine-rich protein 2 (*PfHRP2*), for clinical research. The combination of these electrochemical capabilities in an affordable, hand-held format that is compatible with any mobile phone or network worldwide guarantees that sophisticated diagnostic testing can be performed by users with a broad spectrum of needs, resources, and levels of technical expertise.

SIGNIFICANCE STATEMENT

The ability to perform electrochemical testing in the field, and in resource-limited environments, and to transmit data automatically to “the cloud” can enable a broad spectrum of analyses useful for personal and public health, clinical analysis, food safety, and environmental monitoring. Although the developed world has many options for analysis and web connection, the developing world, however, does not have broad access to either the expensive equipment necessary to perform these tests, or the advanced technologies required for network connectivity. To overcome these limitations, we have developed a simple, affordable, handheld device that can perform all the most common electrochemical analyses, and transmit the results of testing to the cloud with any phone, over any network, anywhere in the world.

INTRODUCTION

Electrochemistry provides a broad array of quantitative methods for detecting important analytes (e.g. proteins, nucleic acids, metabolites, metals) for personal and public health, clinical analysis, food and water quality, and environmental monitoring (1, 2). Although useful in a variety of settings, these methods—with the important exception of blood glucose meters (3, 4)—are generally limited to well-resourced laboratories run by skilled personnel. If simplified and made inexpensive, however, these versatile methods could become broadly applicable tools in the hands of healthcare workers, clinicians, farmers, and military personnel who need accurate and quantitative results in the field, especially in resource-limited settings. Furthermore, if results of testing were directly linked to “the cloud” through available mobile technology, expertise (and archiving of information) could be geographically decoupled from the site of testing. To enable electrochemical measurements to be performed and communicated in any setting, a useful technology must be: i) able to perform complete electrochemical analyses while remaining low in cost, simple to operate, and as independent of infrastructure as possible, and ii) compatible with *any* generation of mobile telecommunications technology, including the low-end phones and 2G networks that continue to dominate communications in much of the developing world.

The parallel development of two successful technologies—mobile health (mHealth) and point-of-care (POC) diagnostics—provides a pair of convergent paths towards a potential solution, although, practically, technical and conceptual connections between them are weak (5, 6). mHealth is the general term given to health-related information technologies that depend on mobile wireless communication for connectivity. Although these networks and devices can capture information relevant to health (and other problems involving chemical and biological sensing) and transmit it globally over the web, they typically do not have the capability to collect data directly, and rely, instead, on (error-prone) entry of data by the user, either alphanumerically or through images. Conversely, while POC diagnostics (e.g. lateral flow immunoassays, urinalysis dipsticks, and hand-held glucometers) provide examples of simple, inexpensive devices that enable minimally trained users to perform chemical testing, these devices are typically limited in function and cannot connect easily to networks for mHealth.

Many devices are now being explored that attempt to connect mHealth with POC testing. Because these systems have been developed in, and often implicitly targeted towards, the developed world, they typically require i) smartphones; ii) custom applications (“apps”); iii) third or fourth generation (3G/4G) data networks; iv) proprietary connectors for sophisticated sensors that interface with diagnostic tests; and in some cases, v) a substantial level of technical sophistication (7-13). As such, these first-generation hybrid mHealth/POC devices are often too expensive, too restricted to a single type of phone, too limited in function, and too reliant on advanced mobile telecommunication technology to be practically applicable in resource-limited settings where 3G/4G networks and smartphones are still not widely used. Although mobile connectivity has spread rapidly across the world, low-end mobile phones and second-generation (2G) networks dominate the telecommunications infrastructure (especially in rural areas) in the developing world (14, 15) and will continue to do so for the foreseeable future (Figure S1). This lack of advanced mobile

technologies in much of the developing world, coupled with myriad operating systems, generations of software, and types of connecting ports among all mobile phones presents a major challenge to any device that requires a specific phone or application to communicate the results of testing.

To provide a system that combines broad flexibility in electrochemical capability with connectivity to the web through widely available technology, we have developed a low-cost (~\$25), handheld device that i) performs all of the most common electrochemical methods; ii) interfaces with a variety of commercially available electrodes; iii) provides on-board vibration to mix samples when necessary; and iv) is simple to operate. For communication of data, we exploited the ubiquity of the hands-free audio port, a nearly universal interface to mobile phones, and designed a protocol to transmit digital data over a live voice connection. This approach guarantees that i) any phone can function as a modem to link the results of testing to a remote facility through any available mobile network (2, 3, or 4G), and that ii) the device does not require any specific software application, operating system, or connector (beyond an audio cable).

We refer to our device as a universal-mobile-electrochemical-detector (uMED) because of i) its universal compatibility with mobile technology, ii) the broad range of electrochemical techniques that it can perform, including various forms of amperometry, coulometry, voltammetry (e.g. cyclic, differential-pulse, square-wave), and potentiometry, and iii) its broad compatibility with different commercial available and paper-based electrodes. Figures 1A–B shows the uMED connected to a low-end mobile phone and sketches the flow of information that links an in-field measurement to a remote facility.

We demonstrate the electrochemical capabilities of the uMED by first comparing the performance of each implemented mode of sensing to a commercial electrochemical analyzer. We then test the uMED in four representative applications: i) as a personal diagnostic device for the detection of glucose in blood, ii) for in-field testing of water quality by detection of heavy metals, and iii) as a low-cost, clinical analyzer for detection of electrolytes, and iv) to perform an electrochemical enzyme-linked immunosorbant assay (ELISA) for the detection of a malarial antigen. We also demonstrate the transmission of POC data over voice through a low-end mobile phone to a remote computer.

MATERIALS AND METHODS

Design of the uMED. Figures 1C–D show a block diagram and circuit schematic that describes the electronic design of the device. Briefly, the device includes: i) a custom-made, three-electrode potentiostat, formed from two operational amplifiers, to perform electrochemical measurements; ii) three digital switches to reconfigure the potentiostat between two- and three- electrode operation and between amperometric or potentiometric measurement, iii) a small vibration motor to mix fluid samples; iv) a dual-channel, 16-bit, digital-to-analog (DAC) converter to set the potentials of the reference electrode (RE) and working electrode (WE); v) a single-channel, 16-bit analog-to-digital (ADC) converter to sample data at high resolution; vi) a pair of sockets to interface with various electrodes; vii) a liquid crystal display (LCD) and three buttons to interface with the user; viii) an audio port to communicate data; ix) a microcontroller to operate the device; x) a serial port to

program the microcontroller; xi) a 3.7-V lithium polymer battery to supply power to the device; and xii) a pair of 3.3-V voltage regulators to supply voltage independently to the digital (microprocessor) and analog (potentiostat and DAC) portions of the circuit. We chose the Atmega328 (Atmel) 8-bit microcontroller for its compatibility with the popular Arduino development environment and its many, programmable channels for input and output. We used a common 2.5-mm, 4-conductor audio cable to connect to the audio port of a mobile phone. The bill of materials for uMED was ~\$25, and the range of electrochemical measurements that we could perform were primarily limited by: i) the practical range of applied voltages (± 2 V); ii) the sample-rate of the ADC (800 Hz); iii) the resolution of the DAC (0.05 mV); and iv) the electronic noise floor (0.5 nA_{rms}). Within these limitations, the uMED can perform the most common electrochemical measurements. We include further technical details, including a circuit diagram (Figure S2) and a bill of materials (Table S1), in the Supporting Information.

Modes of Electrochemical Detection. The uMED can perform (but is not limited to) the following five important types of electroanalytical techniques: i) *cyclic voltammetry* (CV), ii) *chronoamperometry*, iii) *differential pulse voltammetry* (DPV), iv) *square wave voltammetry* (SWV), and v) *potentiometry*. Depending on the selected mode, the microcontroller sets the potentiostat to measure current in a two-electrode (chronoamperometry) or three-electrode (CV, SWV, DPV) configuration, or voltage (potentiometry) in a two-electrode configuration. Figure S3 shows general schemes of the pulse sequences that we used for the different current-based measurements. To compare the performance of the uMED to that of a commercial, bench top electrochemical analyzer—a potentiostat (AutoLab PGSTAT12, Metrohm) for current-based measurements and a pH meter (443i, Corning) for potentiometric measurements—we used both devices to perform a series of five test measurements for five common electrochemical pulse sequences; i) *CV* on a solution of ferricyanide/ferrocyanide redox couple (linear sweep from a potential $E_1 = -0.5$ V to $E_2 = 0.5$ V with a step-size $E_{step} = 2.5$ mV and a scan-rate of 50 mV/s); ii) *chronoamperometry* on a solution of ferrocyanide ions ($E = 0.5$ V for 30 s); iii) *SWV* ($E_1 = -0.2$ V, $E_2 = 0.6$ V, frequency $f = 10$ Hz, peak-to-peak potential $\Delta E = 50$ mV, and $E_{step} = 4$ mV) and iv) *DPV* ($E_1 = -0.2$ V, $E_2 = 0.6$ V, $f = 10$ Hz, $t_1 = 10$ ms, $\Delta E = 140$ mV, $E_{step} = 7$ mV) on solutions of 1-naphthol, which we adapted from previous literature (16, 17); and iv) potentiometry on solutions of sodium and potassium ions. We include more details in the SI Text.

Electrochemical Applications. We used the device in four real applications that involve the detection of: i) glucose in blood by chronoamperometry ii) heavy metals in water by square wave anodic stripping voltammetry (SWASV), iii) sodium in urine by potentiometry, and iv) the malarial antigen *Plasmodium falciparum* histidine-rich protein 2 (*PfHRP2*) through a sandwich, electrochemical ELISA using chronoamperometry for the detection step. The pulse sequence for each application is stored in the device; when the user selects the appropriate mode using a button, the uMED acquires and computes data automatically without further input from the user. For these measurements, we used commercial glucose test strips, screen-printed electrodes (SPEs), and ion-

selective electrodes (ISEs) to evaluate the performance of our device, ensure proper calibration, and determine the limits of detection in all modes of measurement. These electrodes are readily available, and guarantee that the device is immediately applicable to real-world testing.

Detection of Glucose in Blood. For the detection of blood glucose by chronoamperometry, we used glucose test strips (TrueTrak, CVS) and real blood samples (Meter Trax Control, Biorad). For each measurement, we selected glucometry from the uMED menu, inserted the test strip, and applied a droplet of blood ($\sim 5 \mu\text{L}$, a volume easily obtained from a fingerprick) to the test strip. Application of the sample triggered the chronoamperometry sequence (Fig. S3B), which began with an incubation period of 5 s at $E = 0$ followed by a measurement period of 10 s at $E = 0.5 \text{ V}$. The uMED sampled the output signal at 8 Hz and digitally averaged the transient signal over the last $t = 5 \text{ s}$ of the measurement.

Detection of Heavy Metals in Water. For the detection of heavy metals (Zn(II), Cd(II) and Pb(II)) by SWASV we used SPEs (DRP110-CNT, DropSens) that had three electrodes: i) a WE consisting of carbon ink modified by carbon nanotubes (18), ii) a CE consisting of carbon ink, and iii) a RE consisting of Ag/AgCl ink. This procedure requires a four-step pulse sequence (Fig. S3C) that we adapted from Nie et al. (19): i) Cleaning: A positive potential ($E_{\text{clean}} = 5 \text{ V}$, 120 s) applied to the WE oxidizes any impurities from the electrode surface in order to prepare it for the measurement; ii) Deposition: A negative potential ($E_1 = -1.4 \text{ V}$, 120 s) applied to the WE causes metal ions in solution to reduce onto the electrode surface if the potential is more negative than the reduction potential of the metal. The solution must be agitated during these first two steps, so that the kinetics are not limited by the rate of diffusion; iii) Equilibration: The potential maintained at E_1 with no agitation for a short time (30 s) ensures equilibration of the solution; iv) Measurement: SWASV (SWV sequence from E_1 to $E_2 = -0.1 \text{ V}$, at $\Delta E = 50 \text{ mV}$, $E_{\text{step}} = 5 \text{ mV}$, $f = 20 \text{ Hz}$) causes the metals deposited on the electrode surface to re-oxidize and re-dissolve into the solution. The re-oxidation occurs when E matches the oxidation potential of the metal, so that the measured current exhibits a different peak for each metal species.

Typically, a magnetic stirrer is used to provide agitation during deposition and cleaning. To eliminate this added cost and complexity, we, instead, incorporated a small vibration motor (similar to ones using mobile phones) into the uMED to mix the droplet directly on the SPE when necessary. The uMED applies 3.3 V to the motor to vibrate the sample at 530 Hz. This approach enabled us to perform a full measurement by: i) mixing an 80- μL droplet of aqueous sample containing the metal ions with a 20- μL droplet of the reagent solution, on top of the SPE, and then ii) activating the uMED to execute the fully automatic SWASV sequence in which the uMED mixed the sample, applied the pulse sequence, extracted the peak heights of all elements found, and displayed the extracted data to the user. To calculate the concentration of analyte, the uMED performed a baseline correction, calculated the difference between the maximum and minimum current measured, and subtracted the value of the blank (measured on the same SPE).

Detection of Sodium in Urine. To detect sodium in urine by potentiometry, we used an ion-selective electrode (ISE, 27504-30, Cole-Palmer). We prepared a series of urine samples with different levels of sodium from standard urine samples (Liquicheck Urine Chemistry Control, Biorad) and used an ionic strength adjustment buffer (4 M NH_4Cl with 4 M NH_4OH) to adjust the pH to ~ 9.5 . To perform the measurement, we dipped the ISE into each sample, and recorded the potential difference between the RE and the WE. This voltage typically stabilized over a period of 0.5–10 min, with longer times required for lower concentrations.

Detection of Malaria. To perform a malaria immunoassay, we used chronoamperometry to measure the concentration of *Pf*HRP2 through a sandwich ELISA (20) that we augmented for electrochemical detection. The detecting antibody was conjugated to horseradish peroxidase (HRP), which oxidized 3,3',5,5'-tetramethylbenzidine (TMB), a widely used chromogenic substrate. We performed this reaction in a 96-well-plate and then pipetted a drop of solution onto a commercial SPE (DRP110-CNT, DropSens). The uMED detected the oxidized product by performing chronoamperometry for 20 s at $\Delta E = 0.2$ V, sampling the output signal at 20 Hz, and digitally averaging the transient signal over the last $t = 8$ s of the measurement. We include more details for all measurements in the Supporting Information.

Local Acquisition of Data. The uMED contains enough memory (32 kilobytes) to store approximately ten different pulse sequences, the code that operates other functions of the device, and approximately 500 16-bit data points for on-board analysis. The device can, therefore, automatically perform the basic analysis and baseline corrections that are necessary to extract the concentration of an analyte from the raw data, display the measured concentration on the screen, and, if necessary, (using the method described in the next section) upload the information to a remote facility, without user intervention. To analyze the raw data directly, we interfaced a personal computer to the serial port of the uMED through a serial-to-USB converter (FT232RL, FTDI) and used a custom application in MATLAB (Mathworks) to acquire and display the received data.

Telecommunication. The cellular voice-channel is particularly susceptible to signal interruption by burst noise and distortion by voice codecs that render analog modulation inappropriate for transmission of numeric data, such as concentrations of analytes or patient identification numbers. It is, therefore, simpler to transmit these data by digital modulation that can be supplemented with error detection or correction. We implemented a basic frequency-shift keying (FSK) protocol to transmit digital data over the audio channel of a mobile phone during a live connection. Since mobile phones are designed to transmit audio frequency signals in the range of 500 to 3300 Hz (21), we divided the available bandwidth in the voice channel into a band for the data ($f = 500\text{--}1400$ Hz) and a band for the header ($f > 1500$ Hz). We further subdivided the data band into ten, 100-Hz intervals, each corresponding to a single transmitted integer (0–9). We also incorporated a 10-bit binary cyclic-redundancy check (CRC), which is an error-detecting code that allows the validation of uncorrupted

data by the receiving computer and is particularly effective at detecting the kinds of burst errors associated with the mobile voice channel (21, 22).

A pair of standard, 3.5-mm TRRS stereo connectors and a corresponding four-conductor audio cable provided an interface between the uMED and the audio port of a mobile phone. For our experiments, we chose a low-end phone from the Nokia 1100 series (1112) as it is still among one of the most widely used in developing countries (23). We used the stereo and microphone channels of the mobile phone to transmit and receive FSK signals to and from the device. We developed a custom application in MATLAB to establish a live voice link, through the VoIP application Skype (Microsoft, Redmond WA), between the mobile phone and a remote personal computer. This application received and decoded the FSK-based data, and sent an SMS message to back the mobile phone with contents relevant to the data it had received. Figure S4 shows the flow of data in this network.

RESULTS

Device Performance. Figure 2 shows a comparison between analyses performed by the uMED and a commercial electrochemical analyzer—on the same solutions and batch of electrodes or ion-selective electrode (ISE)—for each of the five types of electrochemical methods that we implemented. For *CV* (Fig. 2A), ferricyanide/ferrocyanide provided a model electroactive system; it is the most common redox couple used for probing the performance of modified electrodes. For *chronoamperometry* (Fig. 2B), ferrocyanide provided a model electroactive compound for chronoamperometric detection; it is one of the most common electrochemical mediators that can be detected by amperometric methods. For *SWV* and *DPV* (Fig. 2C), 1-naphthol provided a common substrate used in electrochemical ELISA. For *potentiometry* (Fig. 2D), sodium and potassium ions provided common, clinically relevant electrolytes that we measured over a physiological range of concentrations. Differences between the commercial device and uMED were primarily caused by variations between test strips and electrochemical fluctuations during measurements, and not by differences in the performance of the electronics.

Detection of Glucose by Chronoamperometry. Self-testing of blood glucose using a glucometer and disposable test strips is the most commonly performed point-of-care measurement globally. To test the uMED as a personal glucometer we used both a commercial glucometer (TrueTrak, CVS) and the uMED to measure the concentration of blood glucose in a series of blood samples (Fig. 3A). The uMED displayed a linear relationship relative to the values measured by the glucometer on the same samples within the physiological range of 50–500 mg/dL. The average relative standard deviation (5%) was better than most commercial glucometers (5–20%), and well within the performance criteria set out by the U.S. Food and Drug Administration (3).

Detection of heavy metals in water by SWASV. Lead and cadmium are among the most common toxic heavy metals found in water supplies, and zinc is an essential micronutrient. Trace amounts of these heavy metals can be simultaneously detected by ASV when a differential scanning technique,

such as SWV or DPV, is used for the stripping step (24). These techniques can achieve lower limits of detection than linear sweep voltammetry and chronoamperometry because they use differential sampling to reduce the influence of background and non-Faradaic currents. Here, we use SWV because it can provide better discrimination between metals with similar redox potentials than DPV. Figure 3B shows a calibration plot for detection of lead by SWASV, performed with commercial SPEs. Based on these data, we determined a linear dynamic range of 4–40 $\mu\text{g/L}$ and a detection limit of 4.0 $\mu\text{g/L}$, which is less than the minimum of 10 $\mu\text{g/L}$ imposed by the World Health Organization (25). We also verified the ability of the device to detect Cd, Zn, and Pb simultaneously with SWASV (Fig. 3B, inset).

Detection of Sodium in Urine by Potentiometry. Sodium content in urine is often used to evaluate the amount of fluid within the blood vessels or the overall balance of electrolytes within the body (26). This test may be used when conditions such as hyponatremia (low sodium levels in the body) are suspected (27). We calibrated the potentiometric response of the uMED using standard solutions of sodium and then applied that calibration to a series of urine control samples (Fig. 3C). The systematic error of the measured concentrations ($\sim 8\%$) falls within the certified range of the assayed urine samples ($\pm 14\%$).

Electrochemical ELISA for detection of Malaria. ELISA is a sensitive technique often used for the detection of specific proteins. Although typically quantified by measuring optical absorbance, this biological recognition process can also be measured electrochemically (11, 28). To demonstrate the capability to perform electrochemical ELISA in a research or clinical setting, we measured the concentration of the malarial antigen *PfHRP2* in a sandwich electrochemical ELISA. The quantification of *PfHRP2* is important because the antigen correlates with the parasite load in the body (29). Chronoamperometric measurements (Fig. 3D) performed by the uMED show a linear response for concentrations of *PfHRP2* in the clinically relevant range of 0–150 ng/mL (30). In this proof-of-principle experiment, the limit of detection was 20 ng/mL.

Transmission of Results with a Low-End Mobile Phone. We demonstrated the complete capabilities of our system by measuring the concentration of glucose in a sample of blood from a single user and reporting the result to a remote computer through a low-end mobile phone. Figure 4 shows a typical reporting sequence. We also analyzed the effect of noise and latency of the voice channel on the delivery of FSK-based packets (Figure S5). Briefly, we found that, with our algorithm, the optimal tone length is ~ 34 ms (29 symbols per second), which allows the successful delivery of ~ 1.4 data packets per second at an effective throughput of 31 bits per second. This data rate is sufficient for the transmission of the results of POC testing (it requires, on average, only 2 s to send a value and receive an acknowledgement of receipt).

DISCUSSION

Electrochemical detection is a very attractive method to perform simple, in-field testing for several reasons. i) In contrast to optical sensing, electrochemical signals are not affected by the color of the sample, the lighting conditions, or the presence of particulate matter. ii) The measured current or voltage can be transformed into a numeric output by simple electronics and the results of testing can be made “user-blind” in order to eliminate user bias, or provide security if privacy is a concern. iii) Electrochemical sensors can be used to detect a range of important analytes using different pulse-sequences. The popularity and applicability of hand-held glucometers demonstrates the advantages of electrochemical detection in POC setting. It is, however, impractical to adapt these devices to perform complex analyses (e.g. ASV) because they are engineered to perform a single task.

Recently, Rowe et al. (31) demonstrated that a low-cost (~\$80) potentiostat can be assembled from off-the-shelf components and programmed to perform a variety of electrochemical pulse sequences. This device, however, was designed for benchtop applications: it cannot connect to a mobile phone, and requires a personal computer and USB connection for operation, full-size expensive electrodes to perform measurements, a magnetic stirrer for mixing of samples, and glassware to handle a large sample volume. In another paper, Lillehoj et al. (11) demonstrated a simple potentiostat coupled to a smartphone, although it could only perform chronoamperometry and required a sophisticated microfluidic device to handle the sample.

Here, we aim to solve a greater challenge: can a low-cost device provide a nearly “universal solution” by overcoming the challenges of performing field-based electrochemical analyses in any resource-limited setting. To qualify as a “universal solution”, we have designed the uMED to be i) capable of performing a variety of complete and accurate analyses, ii) simple enough to be used by minimally trained users (Table S2), iii) require a minimum of resources, iv) be able to acquire, process, display, and transmit data automatically, v) be reprogrammable to accommodate new assays, sequences, or standards, vi) be applicable in the field using available technology, and most importantly, and v) be compatible with any phone and network.

We have demonstrated the broad electroanalytical capabilities of our device within a variety of important applications and contexts. The uMED detected blood glucose by chronoamperometry with a linearity and precision equivalent to that of a commercial hand-held glucometer, an indication that the uMED can replace a glucometer. In water samples, the uMED used SWV to provide a comparable limit of detection to other portable electrochemical detectors for heavy metals (32), an indication that a broad spectrum of users (from concerned citizens to budget-constrained municipalities) can use this device to perform in-field agricultural or environmental monitoring of water quality. The uMED measured the sodium content in urine samples by potentiometry with acceptable accuracy over the clinically relevant range, an indication that this device can be used for commonly performed clinical tests for electrolytes (e.g., Na^+ , K^+ , Cl^- , and NH_4^+). The uMED detected a malaria antigen by electrochemical ELISA within the clinically relevant range indicating that this device could benefit researchers studying this disease, as well as aid in the development of other high sensitivity diagnostics.

Since the performance of the uMED and the variety of important pulse sequences that it can perform are comparable to the commercial comparison, the uMED can, in principle, be used in place of an expensive (\$1k–\$50k) benchtop potentiostat in other applications that use these common electrochemical methods. For example, the uMED could use amperometry to detect metabolites (33), proteins, or other biomolecules, or voltammetry to perform immunoassays in which an antibody is labeled with an enzyme (e.g. electrochemical ELISA), metal nanoparticle, or quantum dot (2, 24). The vast and fast-growing field of ion-selective electrodes also provides many opportunities to couple new electrodes with the uMED to measure diverse analytes by potentiometry (34), such as blood urea nitrogen and creatinine (35), which are biomarkers for liver function. Our approach the electrochemical ELISA can also be generalized to many other assays without significant modification of the protocol because we selected the commonly used substrate TMB for HRP-based systems.

The high fixed cost of commercial instrumentation (e.g. electrochemical analyzer, magnetic stirrer) remains one of the largest barriers-to-entry to performing electrochemical analysis in resource-limited settings. By providing an integrated solution at significantly reduced cost, the uMED eliminates the need for these cumbersome instruments in many important applications, makes it more affordable to replace—rather than repair—broken equipment (SI Text), and enables a shift in focus from fixed cost to variable cost-per-test. The use of commercially available screen-printed electrodes and test strips ensures reproducibility, guarantees that the device is useful immediately, and reduces the cost-per-test by decreasing the required sample volume to a single droplet (thereby also reducing significantly the amount of reagent consumed and the need for glassware, compared to reactions performed in bulk). Other costs can be reduced by using disposable plastic pipettes to collect samples, and micro-droppers to dispense precise amounts of reagent. These procedures can be further simplified and cost-per-test reduced by using electrochemical microfluidic paper analytical devices (E μ PADs) that we and others have developed (19, 36-38) to yield comparable performance to SPEs while enabling the sampling of precise volumes by wicking and the pre-storage of all reagents directly on the test strip.

The hand-held, stand-alone format of the uMED, and use of low-power, commercial electronic components offer several important benefits. i) The uMED can be used to collect data by someone who does not own a mobile phone. ii) The device can last for months to years on a single battery charge (SI Text). iii) The electronic components we used are specified to operate stably over a broad range of temperatures (-40–85°C); this stability makes the uMED well suited for use in a variety of climates around the world. Ultimately, however, the temperature range will be governed by the stability of the biochemical reagents and chemical processes (SI Text).

Our adaptable design ensures that the performance and features of the uMED can also be upgraded relatively easily. The compatibility of the uMED with the popular Arduino development environment makes it extremely simple to reprogram the device to alter or add pulse sequences. The dynamic range of the measurements can be adjusted according to need by changing the experimental parameters (e.g. vibration time, deposition time, scan-rate, step-size, feedback resistance). The voltage range, sensitivity, accuracy, and speed (e.g. for dielectric spectroscopy) of the electronics can

all be improved with simple modifications to the system and without significantly affecting the design or cost of the device. The range of analyses can also, in principle, be expanded to include those that require optical techniques (e.g. electro-chemiluminescence, fluorometry, or spectrophotometry) with the addition of an optical detector and/or source. Finally, the throughput of data over voice can be improved as necessary with additional error correction or a dedicated tone generator (39).

Our use of audio-based frequency shift keying to transmit data provides a number of advantages over a smartphone-centric approach; it ensures that the uMED i) is compatible with any phone (from low-end phones to smartphones); ii) is compatible with all generations of cellular networks (2G-4G); iii) does not require any phone-based applications to operate; and iv) guarantees, in combination with our choice of error-detecting code, that uncorrupted data can be uploaded to "the cloud". This approach enables the kind of broad compatibility with mobile technology that presents challenge for all current hybrid mHealth/POC devices because each is typically developed to operate with a specific smartphone that requires custom applications. Nearly 2.8 billion people, however, continue to use low-end phones (62% of worldwide users of mobile phones), and, although the use of smartphones is rising rapidly, it is projected that by 2017 nearly 2.6 billion mobile subscribers will remain without a smartphone (40). A majority of these low-end phones are, and will be, used in low- to middle- income countries such as those found in Sub-Saharan Africa as well as Brazil, Russia, India, China, and Indonesia. These regions alone will account for nearly two billion of the users of low-end phones by 2017 (Fig. S1). Furthermore, although some non-smartphones (feature-phones) may have limited Internet access via 3G, it is impractical to develop compatibility with all the hundreds of variations of software applications, operating systems, types of data ports, and cellular networks. It is clear that compatibility with low-end phones and 2G networks, especially in resource-limited settings, will be a requirement for years to come.

CONCLUSION

The uMED is an inexpensive, versatile tool that links all the most common electrochemical methods with the telecommunication technology most widely available across the globe. The unique combination of capabilities of the uMED enables sensitive and quantitative analysis in resource-limited settings by i) eliminating the need for expensive laboratory *equipment* (such as a commercial potentiostat, pH meter, glassware, or a magnetic stirrer); ii) reducing the need for expensive or limited *resources* (such as reagents or blood samples) by reducing the sample volume to a single droplet (~10–100 μL , depending on the application) on a test strip or SPE; iii) enabling remote *expertise*, monitoring, or archiving to be provided using *any* available mobile technology; and iv) minimizing the *training* required to perform sophisticated electrochemical analyses by using appropriate design to make the system as simple as possible. All that is required is to insert the strip, select the test, apply the sample, and place a phone call.

ACKNOWLEDGEMENTS

This work was funded in part by Bill and Melinda Gates Foundation, under award No. 51308, which provided salary support for A.N., J.H., and A.A.K., and an award from the Defense Threat Reduction Agency and the Lawrence Livermore National Laboratory, No. B603629, which provided salary support for D.C.; A.A.K. was also supported by the NSF Graduate Research Fellowship Program. E.J.M was supported by a fellowship from the Natural Sciences and Engineering Research Council of Canada. M.T.F.A. was supported by an award from Ministerio de Economía y Competitividad Español, No. CTQ2011-25814.

REFERENCES

1. Maxwell EJ, Mazzeo AD, Whitesides GM (2013) Paper-based electroanalytical devices for accessible diagnostic testing. *MRS Bull* 38:309–314.
2. Chikkaveeraiah BV, Bhirde AA, Morgan NY, Eden HS, Chen X (2012) Electrochemical Immunosensors for Detection of Cancer Protein Biomarkers. *ACS Nano* 6:6546–6561.
3. Tonyushkina K, Nichols JH (2009) Glucose Meters: A Review of Technical Challenges to Obtaining Accurate Results. *J Diabetes Sci Technol* 3:971–980.
4. Freckmann G et al. (2012) System accuracy evaluation of 43 blood glucose monitoring systems for self-monitoring of blood glucose according to DIN EN ISO 15197. *J Diabetes Sci Technol* 6:1060–1075.
5. Kahn JG, Yang JS, Kahn JS (2010) “Mobile” health needs and opportunities in developing countries. *Health Affairs* 29:252–258.
6. Chin CD, Chin SY, Laksanasopin T, Sia SK (2013) in *Point-of-Care Diagnostics on a Chip*, eds Issadore D, Westervelt RM (Springer), pp 3–21.
7. Estrin D, Sim I (2010) Open mHealth Architecture: An Engine for Health Care Innovation. *Science* 330:759–760.
8. Lee D-S, Jeon BG, Ihm C, Park J-K, Jung MY (2010) A simple and smart telemedicine device for developing regions: a pocket-sized colorimetric reader. *Lab Chip* 11:120.
9. Liu L, Liu J (2011) Biomedical sensor technologies on the platform of mobile phones. *Front Mech Eng* 6:160–175.
10. Mudanyali O et al. (2012) Integrated rapid-diagnostic-test reader platform on a cellphone. *Lab Chip* 12:2678.
11. Lillehoj PB, Huang M-C, Truong N, Ho C-M (2013) Rapid electrochemical detection on a mobile phone. *Lab Chip* 13:2950–2955.
12. Chin CD et al. (2013) Mobile Device for Disease Diagnosis and Data Tracking in Resource-Limited Settings. *Clin Chem* 59:629–640.
13. Delaney JL, Doeven EH, Harsant AJ, Hogan CF (2013) Use of a mobile phone for potentiostatic control with low cost paper-based microfluidic sensors. *Anal Chim Acta* 790:56–60.

14. Kaplan WA (2006) Can the ubiquitous power of mobile phones be used to improve health outcomes in developing countries? *Global Health* 2:9.
15. Vodafone (2005) Africa: The Impact of mobile phones. *The Vodafone Policy Paper Series* 2.
16. Centi S, Laschi S, Fránek M, Mason A (2005) A disposable immunomagnetic electrochemical sensor based on functionalised magnetic beads and carbon-based screen-printed electrodes (SPCEs) for the detection of polychlorinated biphenyls (PCBs). *Anal Chim Acta* 538:205–212.
17. Chatrathi MP, Wang J, Collins GE (2007) Sandwich electrochemical immunoassay for the detection of Staphylococcal enterotoxin B based on immobilized thiolated antibodies. *Biosens Bioelectron* 22:2932–2938.
18. Fernández-Abedul MT, Costa-García A (2007) Carbon nanotubes (CNTs)-based electroanalysis. *Anal Bioanal Chem* 390:293–298.
19. Nie ZZ et al. (2010) Electrochemical sensing in paper-based microfluidic devices. *Lab Chip* 10:477–483.
20. Noedl H et al. (2005) Simple histidine-rich protein 2 double-site sandwich enzyme-linked immunosorbent assay for use in malaria drug sensitivity testing. *Antimicrob Agents Chemother* 49:3575–3577.
21. Rodman J (2003) The effect of bandwidth on speech intelligibility. *White paper, POLYCOM Inc, USA*.
22. Stigge M, Plötz H, Müller W, Redlich J-P (2006) Reversing CRC—Theory and Practice. *Humboldt-University Berlin, Public Report*.
23. Ledgard JM (2011) Digital Africa. *The Economist: Intelligent Life*. Available at: <http://moreintelligentlife.com/content/ideas/jm-ledgard/digital-africa?page=full> [Accessed May 25, 2013].
24. Chen A, Shah B (2013) Electrochemical sensing and biosensing based on square wave voltammetry. *Anal Methods* 5:2158.
25. World Health Organization (WHO) (2011) Guidelines for drinking-water quality 4th edition. *Geneva, Switzerland*.
26. Kamel KS, Ethier JH, Richardson RMA, Bear RA, Halperin ML (1990) Urine Electrolytes and Osmolality: When and How to Use Them. *Am J Nephrol* 10:89–102.
27. Milionis HJ, Liamis GL, Elisaf MS (2002) The hyponatremic patient: a systematic approach to laboratory diagnosis. *Can Med Assoc J* 166:1056–1062.
28. Pyun JC, Lee HH, Lee CS (2001) Application of an amperometric detector to the conventional enzyme-immunoassay (EIA). *Sens Actuators B Chem* 78:232–236.
29. Dondorp AM et al. (2005) Estimation of the total parasite biomass in acute falciparum malaria from plasma PfHRP2. *PLoS medicine* 2:e204.
30. Kifude CM et al. (2008) Enzyme-Linked Immunosorbent Assay for Detection of Plasmodium falciparum Histidine-Rich Protein 2 in Blood, Plasma, and Serum. *Clin Vaccine Immunol* 15:1012–1018.

31. Rowe AA et al. (2011) CheapStat: An Open-Source, “Do-It-Yourself” Potentiostat for Analytical and Educational Applications. *PLoS ONE* 6:e23783.
32. Yantasee W et al. (2007) Electrochemical sensors for the detection of lead and other toxic heavy metals: the next generation of personal exposure biomonitors. *Environ Health Perspect* 115:1683–1690.
33. Nie ZZ, Deiss FF, Liu XX, Akbulut OO, Whitesides GM (2010) Integration of paper-based microfluidic devices with commercial electrochemical readers. *Lab Chip* 10:3163–3169.
34. Bühlmann P, Chen LD (2012) in *Supramolecular Chemistry: From Molecules to Nanomaterials*, eds Steed JW, Gale PA (Wiley & Sons).
35. Lad U, Khokhar S, Kale GM (2008) Electrochemical Creatinine Biosensors. *Anal Chem* 80:7910–7917.
36. Dungchai W, Chailapakul O, Henry CS (2009) Electrochemical Detection for Paper-Based Microfluidics. *Anal Chem* 81:5821–5826.
37. Liu H, Xiang Y, Lu Y, Crooks RM (2012) Aptamer-Based Origami Paper Analytical Device for Electrochemical Detection of Adenosine. *Angew Chem Int Ed* 51:6925–6928.
38. Lan W-J et al. (2013) Paper-based electroanalytical devices with an integrated, stable reference electrode. *Lab Chip* 13:4103–4108.
39. Dhananjay A et al. (2010) Hermes: data transmission over unknown voice channels. *Proceedings of the sixteenth annual international conference on Mobile computing and networking*:113–124.
40. eMarketer, Inc. (2014) Smartphone Users Worldwide Will Total 1.75 Billion in 2014. Available at: <http://www.emarketer.com/Article/Smartphone-Users-Worldwide-Will-Total-175-Billion-2014/1010536> [Accessed March 9, 2014].

Figure 1: (A) An image of the uMED interfaced to a commercial glucose test-strip, and a low-end mobile phone through a standard audio cable, for transmission of data over voice. (B) A schematic of the connections and flow of data from the electrodes, through the uMED, to the remote back end. (C) A block diagram of the hardware and interconnections of the device. (D) The circuit design for the reconfigurable potentiostat.

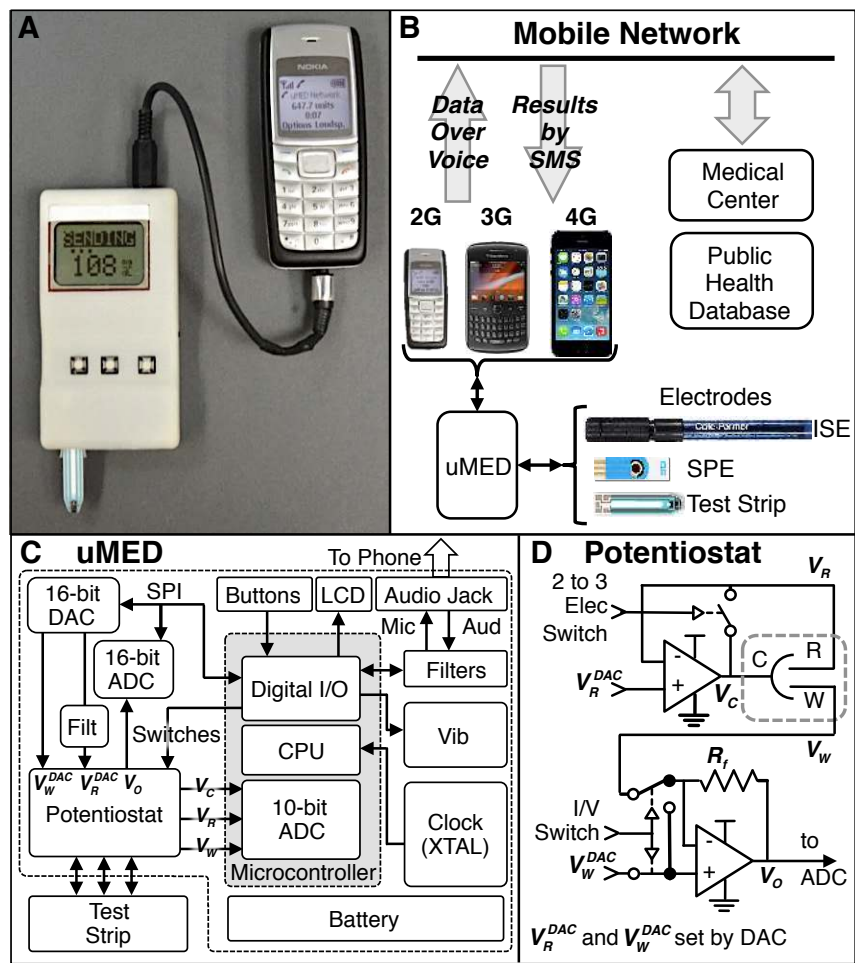

Figure 2: (A) A cyclic voltammogram of 2.5-mM ferricyanide/ferrocyanide in 0.1-M KCl. (B) The measured current vs. time for chronoamperometric detection of 1-mM ferrocyanide in 0.1-M KCl. (C) Differential-pulse and square-wave voltammograms of 1-mM 1-naphthol in 100-mM Tris, 100-mM NaCl. (D) Detection of $[K^+]$ and $[Na^+]$ with potentiometry in an ionic strength adjuster.

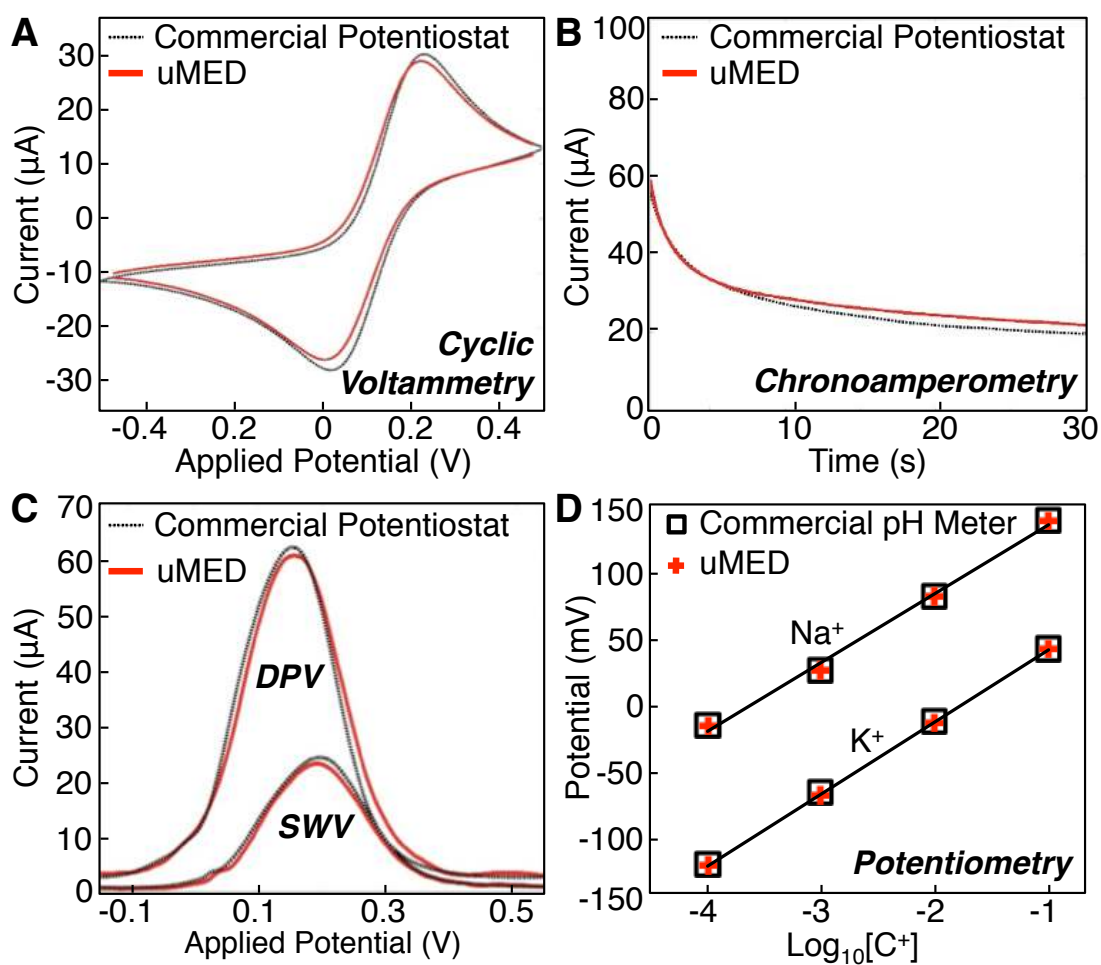

Figure 3: (A) A calibration plot for [glucose] in assayed samples of human blood measured by chronoamperometry. Inset: Transient current for five representative concentrations of glucose (107, 150, 215, 298, and 408 mg/dL). (B) A calibration plot for [Pb] measured by SWASV. Inset: Square-wave voltammograms for Zn, Cd, and Pb at three concentrations (5, 10, and 20 $\mu\text{g/L}$). We performed an independent baseline correction on each peak. (C) Potentiometric measurement of $[\text{Na}^+]$ in assayed samples of human urine. (D) A calibration plot for [*Pf*HRP2] in PBS (1x) measured by chronoamperometry. All error bars indicate the standard error ($n = 7$).

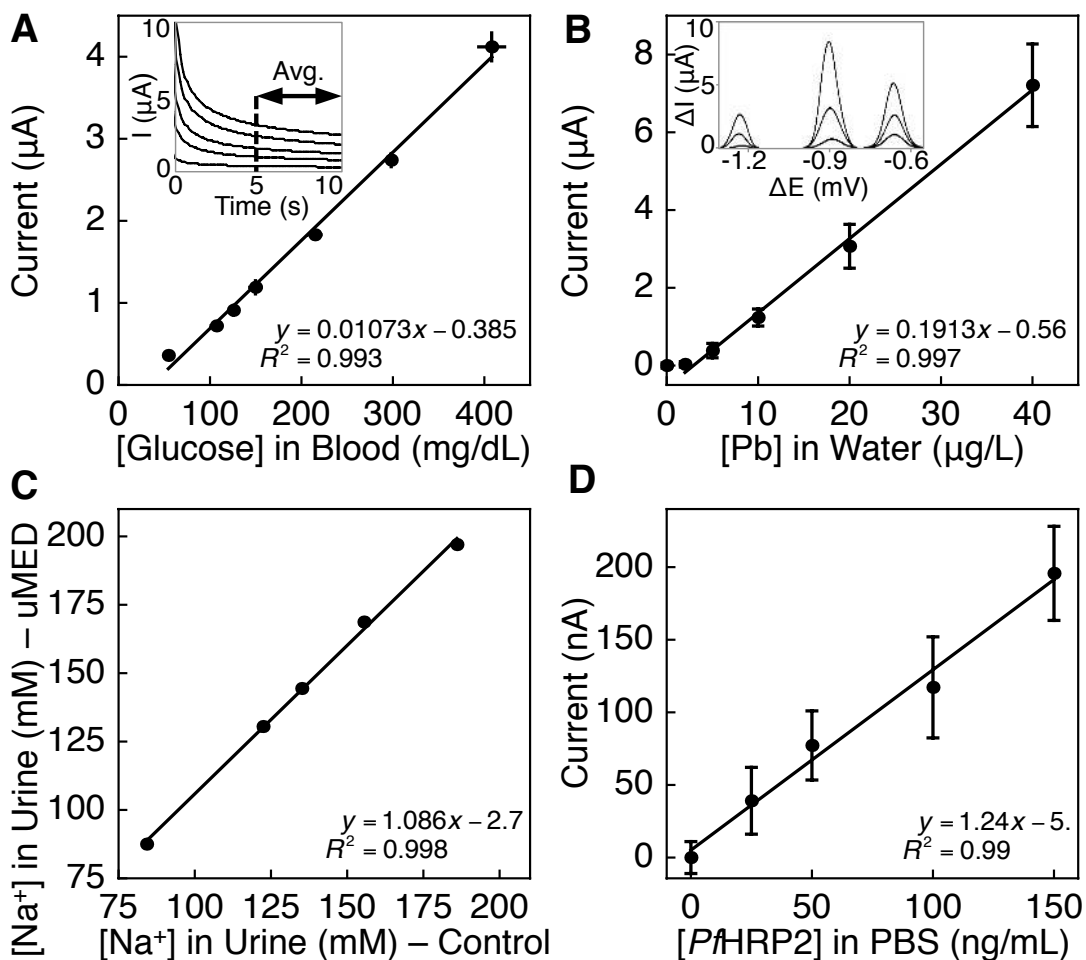

Figure 4: A demonstration of the uMED network in operation. (A and B) The local user made a blood-glucose measurement with the uMED. (C) Upon completion, the device automatically began to transmit repeated packets containing the measured value. (D) The user then connected the device to a mobile phone and placed a call to a remote Skype-in number. (E and F) The remote application i) automatically recorded the audio-based data, ii) extracted the encoded value, iii) verified that it was error-free, iv) sent an acknowledgment tone back to the uMED, and v) sent an SMS message (with relevant information) back to the local user's mobile phone. (G and H) The local user received the acknowledgment (G) and SMS (H).

