

 Open access • Journal Article • DOI:10.1063/1.95688

Unstable resonator cavity semiconductor lasers — Source link

Joseph Salzman, T. Venkatesan, Robert J. Lang, M. Mittelstein ...+1 more authors

Published on: 01 Feb 1985 - Applied Physics Letters (American Institute of Physics)

Topics: Output coupler, Injection seeder, Semiconductor laser theory, Longitudinal mode and Laser

Related papers:

- [Etched-mirror unstable-resonator semiconductor lasers](#)
- [Injection laser with an unstable resonator](#)
- [High power, nearly diffraction-limited output from a semiconductor laser with an unstable resonator](#)
- [Coherence and focusing properties of unstable resonator semiconductor lasers](#)
- [Unstable optical resonators for laser applications](#)

Share this paper:    

View more about this paper here: <https://typeset.io/papers/unstable-resonator-cavity-semiconductor-lasers-4xnexyv9d4>

Unstable resonator cavity semiconductor lasers

J. Salzman, T. Venkatesan,^{a)} R. Lang, M. Mittelstein, and A. Yariv
California Institute of Technology, Pasadena, California 91125

(Received 12 October 1984; accepted for publication 5 November 1984)

GaAs heterostructure lasers with unstable resonator cavities were demonstrated for the first time with both curved mirrors fabricated by etching. Typical output powers of 0.35 W were observed in a stable, highly coherent lateral mode. The laser operated stably in a single longitudinal mode over a large range of injection currents. The external quantum efficiency was 70% of that of a similar laser with both mirror facets cleaved implying good output coupling of the energy from the entire region.

The output power of semiconductor lasers may be increased by increasing the lasing volume. However, this may cause a degradation in the coherence properties of the laser output. In particular, when the width of the laser is increased above $\sim 10\ \mu\text{m}$, higher order lateral modes of the waveguide are excited and a multimode optical field is obtained.¹ Further increase of the lateral width of the gain medium generally causes filamentation, giving rise to nonuniform near-field optical distribution in the plane of the p - n junction. This results in inefficient extraction of radiant energy from the gain medium with unpredictable changes in the field distribution with increasing injection current.²⁻⁴ The thickness of the active layer is also limited to $\sim 0.4\ \mu\text{m}$ if single transverse mode operation is desired.^{1,5} As a result, the typical volume of the lasing region in semiconductor lasers, V , does not exceed $\sim 1000\ \mu\text{m}^3$. This is one of the primary limiting factors in trying to increase the total power radiated coherently by the laser.

One method of increasing the volume of the active region while preserving the high degree of coherence in the output is to synchronize the fields generated by several separate lasers.⁶ This may be achieved, for example, via mutual phase locking of several lasers through their overlapping fields.⁷⁻⁹ Phase-locked multichannel diode lasers, however, usually support several lateral modes,¹⁰ and special means are required to suppress all but one of the modes of the combined structure.¹¹⁻¹³

An alternate approach is the use of an unstable resonator.¹⁴ It is well known that for laser systems characterized by a high single pass gain and by a Fresnel number greater than unity, the unstable resonator is the optimal laser cavity.¹⁵⁻¹⁷ It provides a large mode volume, nearly complete energy extraction from the laser medium in a collimated diffraction limited beam, and, for some range of the resonator parameters, a substantial discrimination against higher order lateral modes.¹⁸ Furthermore, unstable resonator lasers with reasonably high magnification are less sensitive than lasers with plane mirrors to inhomogeneities of the medium.¹⁶ In particular, the self-focusing behavior of lasing filaments³ in semiconductor lasers can be counterbalanced effectively by the magnifying (spreading) effect of the cavity.¹⁶

In a preliminary experiment with semiconductor lasers in which one mirror was cleaved and part of the other mirror was polished to a concave cylindrical surface, Bogatov *et al.*¹⁹ were able to get laser emission from a broad area struc-

ture. The emission had a stable lateral distribution with a single longitudinal mode superimposed on a spectrally broad feature. Similar experiments with encouraging results were recently reported by Craig *et al.*²⁰ However, in the above-mentioned experiments the resonant structure was a combination of a Fabry-Perot cavity, with a magnifying perturbation in the center of one of the mirrors. In this letter we report on the fabrication and the operation of GaAs lasers with both mirrors etched to convex surfaces with no planar feedback in any part of the cavity. The lateral width of the gain region was defined by an $80\text{-}\mu\text{m}$ contact stripe and the etched cylindrical surfaces were $250\ \mu\text{m}$ wide as depicted in Fig. 1. We show that this high loss cavity may support a single transverse and single longitudinal mode with threshold current and quantum efficiency comparable to those of cleaved broad area lasers and with relatively high output power.

GaAs/GaAlAs double heterostructures (DH) were grown by liquid phase epitaxy and subsequently standard photolithographic techniques were used to form resist patterns on top of the DH wafers with the shape of the desired mirrors. These were then etched in a $\text{H}_2\text{SO}_4\text{:H}_2\text{O}_2\text{:H}_2\text{O}$ (1:8:1) solution at $5\ ^\circ\text{C}$ for 4 min [see Fig. 1(b)]. In some devices the mirrors were produced by a hybrid wet and reactive ion etching technique developed by us.²¹ The device fabrication was completed by contact metallization. The two parameters of importance in the design of an unstable resonator laser are the magnification M and the equivalent Fresnel number, $N_{\text{eq}} = (a^2 n / 8L\lambda) (M - 1/M)$, where a , n , L , and λ are the laser width, index of refraction, length, and wavelength, respectively (see Fig. 1).¹⁴ Increasing the magnification helps in suppressing filamentation, but results in higher losses and, hence, a higher threshold current for laser operation and a lower external quantum efficiency.²² The lowest value of M that can provide a coherent single mode output was estimated in the following way: we modelled a laser filament as the result of a local quadratic inhomogeneity of the index of refraction^{2,3} and calculated the combined effect of a curved mirror and the index inhomogeneity on the propagation of such a filament.²³ By requiring that a $10\text{-}\mu\text{m}$ -wide spot be smeared out over the laser width after one round trip, we arrived at the magnitude of $R \sim L$ for the radius of curvature of the mirrors. In our experiment $R = 200\ \mu\text{m}$ and $L = 250\ \mu\text{m}$ resulting in a magnification of¹⁶

$$M = \left(1 + \frac{L}{R}\right) + \left(\frac{L^2}{R^2} + \frac{2L}{R}\right)^{1/2} \simeq 4.3. \quad (1)$$

^{a)} Visiting Associate at Caltech from Bell Communications Research, Murray Hill, New Jersey 07974.

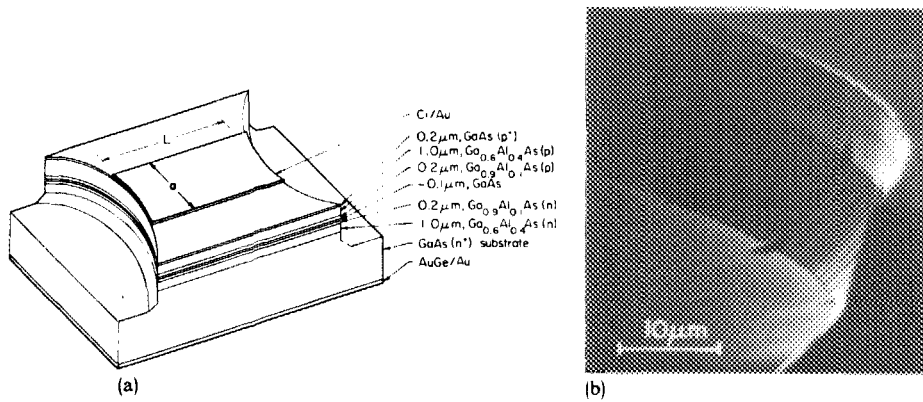

FIG. 1. (a) Schematic picture of the unstable resonator cavity on a double heterostructure GaAlAs/GaAs laser. (b) SEM picture of the etched curved mirrors.

With R and L fixed, N_{eq} depends only on the laser width. This width was determined as the widest beam that can be coupled out from the laser through the curved mirror according to the laws of refraction, resulting in $N_{eq} \approx 50$.

Figure 2(a) shows the near-field pattern of the unstable resonator laser for $I = 1.8I_{th}$ with the laser driven with 100-ns pulses at 500-Hz repetition rate. The field distribution is very stable as can be observed in Fig. 2(b), where the near-field pattern is recorded for different values of the injection current. In Fig. 3 we show the spectrally resolved near-field distribution for different values of the injection current. The laser operates in a single longitudinal mode up to $I \approx 2I_{th}$ and in only two modes up to $I = 2.6I_{th}$. The far-field pattern for two different currents is depicted in Fig. 4. We note that the far-field distribution is very wide, as expected from a theoretical analysis of the symmetric unstable cavity¹⁶ (unlike the far-field distribution reported in Ref. 19). In fact, the recorded distributions shown in Fig. 4 are limited by the acceptance angle of our optical system. By scanning a photodetector manually we were able to detect some radiation at angles as high as 70° from the laser axis. If a collimated output is desired, a confocal unstable resonator geometry should be used.¹⁷ This cavity is equivalent to the symmetric unstable cavity used in our experiment, and has been shown to provide a nearly diffraction limited far-field distribution.^{16,17} Although the fabrication of a laser with a confocal unstable resonator involves stringent requirements on R_1 , R_2 , and L , the primary limitation is the etching of both mirrors with high quality curved surfaces. The operation of the lasers reported here suggests that the confocal unstable resonator

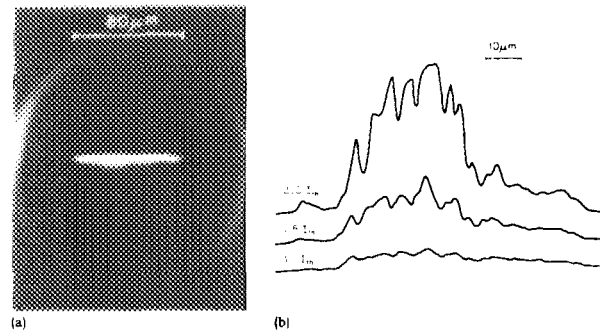

FIG. 2. (a) Near-field pattern of the unstable resonator laser for $I = 1.8I_{th}$. (b) Recorded near-field intensity distribution for three different values of the injection current.

semiconductor laser is a feasible device. The ripples observed in Figs. 3 and 4 are most likely due to variations in the field distribution of the lowest order mode,¹⁶ and not due to interference between different lateral modes. In order to have a single lateral mode (with higher losses for other lateral modes) N_{eq} must be $< N_{eq}(\text{crit})$ ²⁴ where

$$N_{eq}(\text{crit}) \approx 11.5 / (\ln M)^3 = 3.7$$

and this condition is fulfilled in our case. Single mode operation was confirmed by observation of a high degree of spatial coherence of the field.²⁵ The threshold current and external quantum efficiency for the unstable cavity resonator lasers were $I_{th} = 700$ mA and $\eta_d = 0.22$, respectively. These figures compare favorably with the measured values $I_{th} = 300$ mA and $\eta_d = 0.32$ for cleaved broad area (reference) lasers fabricated from the same wafer. By assuming that the

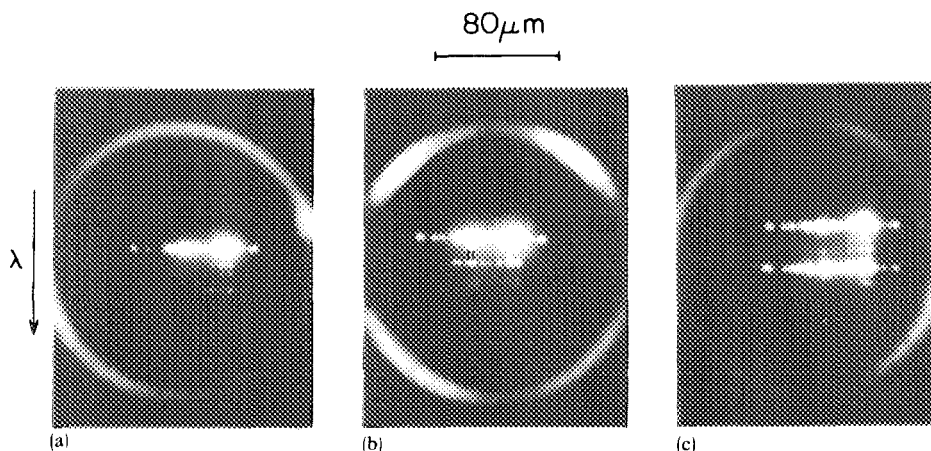

FIG. 3. Spectrally resolved near field at (a) $I = 1.5I_{th}$, (b) $I = 2.0I_{th}$, and (c) $I = 2.5I_{th}$.

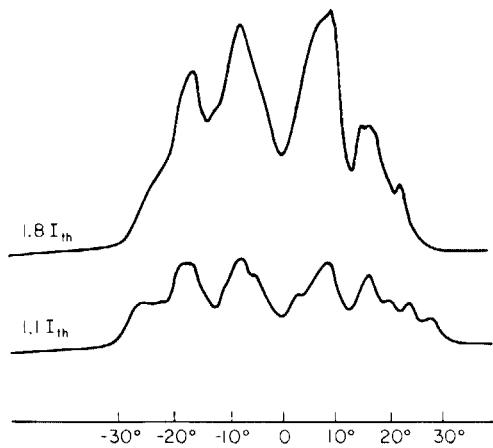

FIG. 4. Recorded far-field intensity distribution (in relative units) as a function of far-field angle. The acceptance angle of the camera is $\pm 30^\circ$.

fraction of energy lost by diffraction is $\sim(1 - 1/M)$ per pass,¹⁶ it may be shown that

$$\frac{\eta_d(\text{unstable})}{\eta_d(\text{cleaved})} \simeq \frac{1 - R_e}{M - R_e},$$

where R_e is the facet reflectivity. Using this expression, we get $\eta_d(\text{unstable}) \simeq 0.17\eta_d(\text{cleaved})$, while according to the measured value, $\eta_d(\text{unstable}) \simeq 0.7\eta_d(\text{cleaved})$. This implies that the diffraction losses are reduced drastically by the field distribution inside the cavity that results from the combination of the curved mirror feedback and the waveguiding effect. Finally, we would like to mention that typical output powers of 0.35 W at $I \sim 4I_{th}$ were observed in a stable lateral mode.

In conclusion, we have demonstrated the operation of an unstable resonator cavity semiconductor laser with two curved and etched mirror facets. The external quantum efficiency was comparable to that of lasers with both cleaved mirrors and optical power as high as 0.35 W with a high degree of coherence was demonstrated.²⁵ The preliminary results show that the unstable resonator geometry is a promising approach for coherent, high power semiconductor lasers.

This research is supported by grants from the Air Force

Office of Scientific Research and the Office of Naval Research. J. S., R. L., and M. M. would like to acknowledge the support of the Bantrell post-doctoral fellowship, the National Science Foundation, and the German National Scholarship Foundation, respectively.

¹H. Yonezu, I. Sakuma, K. Kobayashi, T. Kamejima, M. Ueno, and Y. Nannichi, *Jpn. J. App. Phys.* **12**, 1585 (1973).

²G. H. B. Thompson, *Optoelectronics* **4**, 257 (1972).

³M. Cross, *Phys. Status Solidi A* **16**, 167 (1973).

⁴P. A. Kirkby, A. R. Goodwin, G. H. B. Thompson, and P. R. Selway, *IEEE J. Quantum Electron.* **QE-13**, 705 (1977).

⁵H. C. Casey, Jr. and M. B. Panish, *Heterostructure Lasers* (Academic, NY, 1978).

⁶V. S. Letokhov, *Sov. Phys. Technical Physics* **10**, 629 (1965).

⁷D. R. Scifres, R. D. Burnham, and W. Streifer, *Appl. Phys. Lett.* **33**, 1015 (1978).

⁸D. R. Scifres, W. Streifer, and R. D. Burnham, *IEEE J. Quantum Electron.* **QE-15**, 917 (1979).

⁹E. Kapon, J. Katz, and A. Yariv, *Opt. Lett.* **9**, 125 (1984).

¹⁰J. Katz, E. Kapon, C. Lindsey, S. Margalit, U. Shreter, and A. Yariv, *Appl. Phys. Lett.* **43**, 521 (1983).

¹¹E. Kapon, C. Lindsey, J. Katz, S. Margalit, and A. Yariv, *Appl. Phys. Lett.* **45**, 200 (1984).

¹²E. Kapon, J. Katz, S. Margalit, and A. Yariv, *Appl. Phys. Lett.* **45**, 600 (1984).

¹³A. E. Siegman, *Proc. IEEE* **53**, 277 (1965).

¹⁴A. E. Siegman and R. W. Arrathoon, *IEEE J. Quantum Electron.* **QE-3**, 156 (1967).

¹⁵Yu. A. Anan'ev, *Sov. J. Quantum Electron.* **1**, 565 (1972).

¹⁶A. E. Siegman, *Appl. Opt.* **13**, 353 (1974).

¹⁷R. L. Sanderson and W. Streifer, *Appl. Opt.* **8**, 2129 (1969).

¹⁸A. P. Bogatov, P. G. Eliseev, M. A. Man'ko, G. T. Mikaelyan, and Yu. M. Popov, *Sov. J. Quantum Electron.* **10**, 620 (1980).

¹⁹R. R. Craig, L. W. Casperson, G. A. Evans, and J. J. Yang, paper presented at Conference on Lasers and Electro-optics, Anaheim, June 19-22, 1984.

²⁰J. Salzman, T. Venkatesan, S. Margalit, and A. Yariv, *J. Appl. Phys.* (to be published).

²¹The radiation lost by diffraction is absorbed in the medium outside of the gain region. In several devices with one of the mirrors cleaved we observed a second laser threshold in which this medium was optically pumped to transparency and the laser output was in the form of a 250- μm -wide spot.

²²L. Casperson and A. Yariv, *Appl. Phys. Lett.* **12**, 355 (1968).

²³M. J. Smith, *Appl. Opt.* **20**, 4148 (1981).

²⁴The degree of spatial coherence of the laser output was measured by imaging the near field on a double slit and measuring the visibility of the interference pattern (Young's experiment). This experiment will be reported elsewhere.