

# Use of Track Geometry Measurements for Maintenance Planning

WILLEM EBERSÖHN AND ERNEST T. SELIG

Track geometry measurements are discussed as a means of evaluating the functional condition of track. Examples are given of track vertical profile geometry data from a heavy haul line obtained by a laser survey and by a track recording car. Bad sites with rapid geometry deterioration are compared with good sites with stable geometry. The mid-chord ordinate measurement procedure used by the recording car is described, and two methods to backcalculate the track longitudinal profile from this measurement are presented. A definition of track roughness based on the vertical geometry data is proposed. Examples are given of the use of roughness to identify track sections having similar maintenance needs and to project the amount of traffic when geometry corrections will be required. The results of the research suggest that considerable potential for cost savings exists from use of track geometry data in maintenance planning beyond that normally considered by the railroad where the measurements were made.

Track condition monitoring is the primary input for maintenance planning and execution. The condition of a track may be categorized as either functional or structural. The functional condition reflects the serviceability of a track indicated by its geometry, while the structural condition is represented by the strength and stiffness properties of the track which affect the ability of the track to perform satisfactorily. Both conditions should be monitored, but this paper will concentrate on interpreting the functional condition of the track. A companion paper in this Record presents the corresponding information on the structural condition.

A track maintenance engineer must ensure that the track is above a certain specified serviceability level and thus should monitor the functional condition at regular intervals. This monitoring is done by foot, by motorized visual inspections, or by mechanized geometry measurements. An example of the latter is the track recording car, usually referred to as the track geometry car.

The recording car is primarily being used by most railroads to identify geometry exceedances, but a number of railroads are starting to calculate track indices from various geometry measurements to monitor track deterioration. However there are additional characteristics relating to vertical geometry (track profile) which should be considered for functional condition evaluation. This paper discusses the geometry results obtained in an extensive track performance investigation conducted in South Africa, and shows how they could be used to evaluate the track functional condition and to determine the need for maintenance.

Some of the concepts discussed in the paper may have been considered in the past by most railroads who use geometry cars. However, the concepts which have been considered have been applied in

a variety of different ways with varying degrees of reliance and success. What the measurements represent is not always appreciated. This paper attempts to clarify the concepts and ways of interpreting the geometry measurements by using examples from one operating section of track where a detailed investigation was conducted.

## SITE DESCRIPTION

The Heavy Haul Coal Line in South Africa was chosen for this investigation because it is an ideal site for conducting applied railway research, due to its high annual tonnage and heavy axle loads. The Coal Line of SPOORNET (South African Railway Organization) links the Transvaal coal fields with the east coast of South Africa (1). The length of the line is 586 km and it was built between 1973 and 1976. The initial axle loads were limited to 185 kN (18.5 tonnes) for the wagons and 220 kN (22 tonnes) for the locomotives. The axle loads were gradually increased to 260 kN (26 tonnes) for the wagons and 292.5 kN (29 tonnes) for the locomotives in 1988. This increased load was handled by a major upgrading program consisting of doubling the line, strengthening the superstructure and reducing the grades for the loaded trains.

Two 200-m (656-ft) sections of tangent track on the Coal Line with reasonably uniform conditions were selected for this study to provide both "good" and "bad" track under the same traffic and environmental conditions. The good section required little maintenance and the bad section needed frequent spot maintenance. The high maintenance input in the bad section was associated with substructure-related problems, resulting in rapid loss of surface geometry. The spot maintenance consisted of cleaning the ballast and tamping to improve the geometry.

Within the 200-m (656-ft) bad section was a 100-m (328-ft) portion with most of the problems. This portion will be termed the bad site in this paper. A corresponding 100-m (328-ft) good site was selected from within the good section.

The superstructure consisted of continuously welded 60 kg/m (121 lb/yd) S60 chrome manganese steel rails fastened to the 285 kg (628 lb) concrete ties with Fist type fasteners on high density polyethylene rail seat pads. The butt (shop) welds and thermit (field) welds were evenly spaced throughout each section, with one additional thermit weld in the bad section. The surface of each section was visually inspected for mud boils and surface drainage conditions. Evidence of these problems was only observed in the first 100 m (328 ft) of the bad section and these occurred randomly along the length of the section. The ballast is a dolomite crushed rock with an average layer thickness of 300 mm (12 in.) below the tie in the bad section and 415 mm (16 in.) in the good section. More information on the structural condition of the various track components can be obtained in the companion paper in this Record.

W. Ebersöhn, Department of Civil Engineering, University of Pretoria, Pretoria, 0002, Republic of South Africa. E. T. Selig, Department of Civil and Environmental Engineering, Marston Hall, Box 35205, University of Massachusetts, Amherst, Mass. 01003-5205.

## FUNCTIONAL CONDITION MEASUREMENTS

The functional condition of the test sections was monitored by surveying the track in both the loaded and the unloaded conditions, and measuring the track geometry with a recording car. This allowed a comparison of the absolute functional condition, in a loaded and unloaded state, with the geometry car results.

### Unloaded Track Longitudinal Profiles

The unloaded track profiles were measured using a digital level taking elevation readings on the top of both rails at every second tie along the track. The profiles were measured before tamping, directly after tamping and during subsequent traffic. The top section of Table 1 gives the cumulative traffic up to each set of measurements. The values in parentheses indicate the traffic since the previous tamp. The profiles were tied into an elevation reference system to determine the absolute settlement.

As a typical example, the unloaded absolute longitudinal profile of both sites for both rails over the worst portions of both sections are indicated in Figure 1. The wavelengths and amplitudes of the track indicated in Figure 1 represent the actual wave form in the longitudinal profile of the two rails.

### Loaded Track Longitudinal Profiles

Loaded profiles were measured using the same digital level taking elevation readings at every second tie on bar-coded scales fixed to both sides of the rear axle of a two-truck coal wagon with a 260-kN (26-tonne) axle load. Only two sets of loaded profile measurements could be obtained as indicated in the schedule given in the middle section of Table 1. Figure 2 shows a typical example of the loaded absolute longitudinal profile of both rails. These lines represent the actual deflected wave forms for both rails, as followed by a loaded axle.

TABLE 1 Functional Condition Measuring Schedule

(a) Unloaded Profile Schedule in Cumulative Traffic					
Bad Site	MGT	GN	Good Site	MGT	GN
Before Tamp (11.720)	0.0	0.0	Before Tamp (11.720)	0.0	0.0
After Tamp	0.0	0.0	After Tamp	0.0	0.0
	0.165	1.65		0.224	2.24
	0.621	6.21			4.60
	1.171	1.71			10.10
	6.381	63.81			62.21
(b) Loaded Profile Schedule in Cumulative Traffic (MGT)					
Bad Site	GN	Good Site	MGT	GN	
Before Tamp (13.162)	0.0	0.0	Before Tamp (13.162)	0.0	0.0
After Tamp	0.0	0.0	After Tamp	0.0	0.0
	0.316	3.16		0.046	0.460
(c) Recording Car Schedule in Cumulative Traffic (MGT)					
Bad Site	GN	Good Site	MGT	GN	
Before Tamp (8.470)	0.0	0.0	Before Tamp (8.470)	0.0	0.0
After Tamp	0.0	0.0	After Tamp	0.0	0.0
	0.165	1.65		1.006	10.06
	1.171	17.71		6.348	63.48
	6.513	65.13			

Note: Values in ( ) indicate traffic in MGT since previous tamp.

## Track Recording Car

### Measurements

The track geometry was measured using a Plasser EMV80 recording car. The mid-chord ordinate readings are taken over a 7 m (23 ft) chord length at every 250 mm (9.8 in) along the rail. Mid-chord ordinate measurements will be referred to as the "mid-chord profiles" of the track. Versine (alignment) and cant (cross-level) measurements were also obtained, but only the profile results will be used in this paper. The car is equipped with an adjustable axle load configuration, allowing different axle loads to be applied to the track depending on its line classification.

The bottom section of Table 1 gives the cumulative traffic of each measuring run. The runs were measured at both 260 kN (26 tonne) and 160 kN (16 tonne) axle loads. Only the 260 kN (26 tonne) axle results will be discussed in this paper. Figure 3 shows the mid-chord profile measurements for both sites before and after tamping and after 6.5 MGT (65 GN) traffic.

### Mid-Chord Profile Measuring Principle

The frame of the EMV80 is used as an inertial reference to measure the mid-chord ordinate. The mid-chord profile is a function of the actual wave form of the track from which the absolute position of the top of rail is eliminated. In effect the profile obtained with the geometry car mid-chord ordinate reading represents the actual geometry passed through a distorted filter of track wave-lengths. The quantities measured are designated by  $z$  in Figure 4, which shows the effect of the loaded wheels relative to the unloaded measuring trolley. The mid-chord ordinate  $h_n$  is calculated using the following equation:

$$h_n = \frac{z_{n-1} + z_{n+1}}{2} + z_n \quad (1)$$

The symmetrically spaced measuring positions have the advantage that any longitudinal rotation of the vehicle frame cancels out in the calculation of  $h_n$ .

The mid-chord ordinate measuring principle does not represent the actual profile of the track as mentioned above. Figure 5 shows the mid-chord ordinate response to an irregularity that is shorter than the chord being used to measure it. Note that the shape of the profile does not look like the actual shape of the irregularity.

The response of a three-point mid-chord ordinate measuring system to sinusoidal inputs is as follows:

$$h_n(\lambda) = \left(1 - \cos \frac{2\pi l}{\lambda}\right) Z_n(\lambda) \quad (2)$$

where

$\lambda$  = wavelength of a sinusoidal component of a longitudinal rail profile,

$l$  = half the chord length of the measuring system,

$h_n(\lambda)$  = chord system response to wavelength, and

$Z_n(\lambda)$  = longitudinal profile amplitude for a wave length.

The response function  $H(\lambda)$  is given by the following:

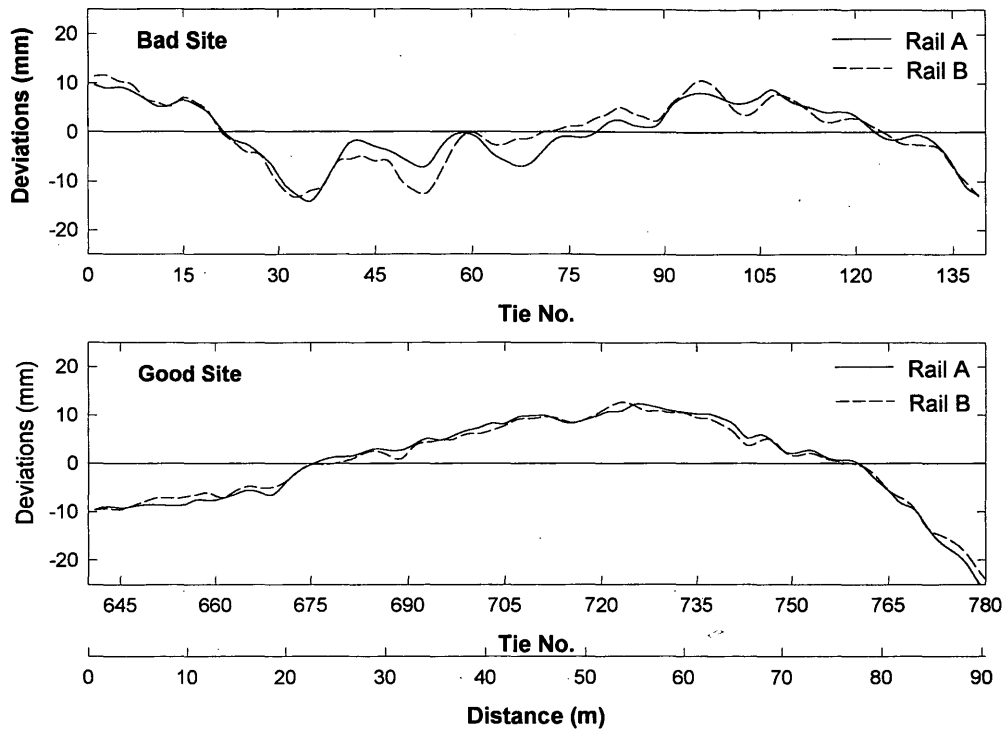

FIGURE 1 Unloaded absolute longitudinal profiles for both rails.

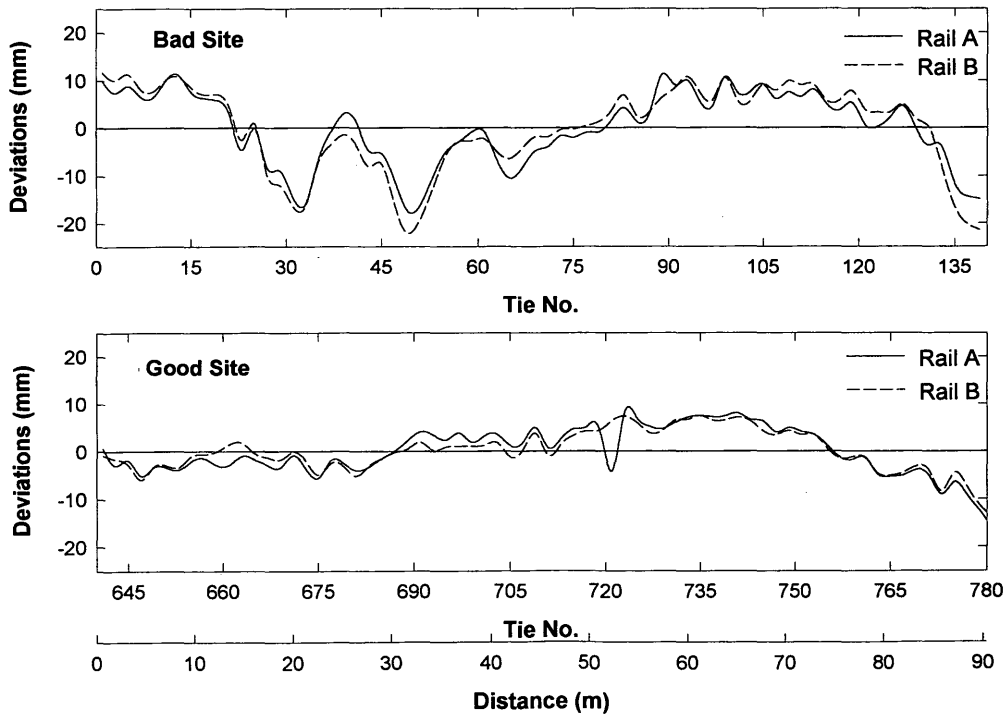

FIGURE 2 Loaded absolute longitudinal profiles for both rails.

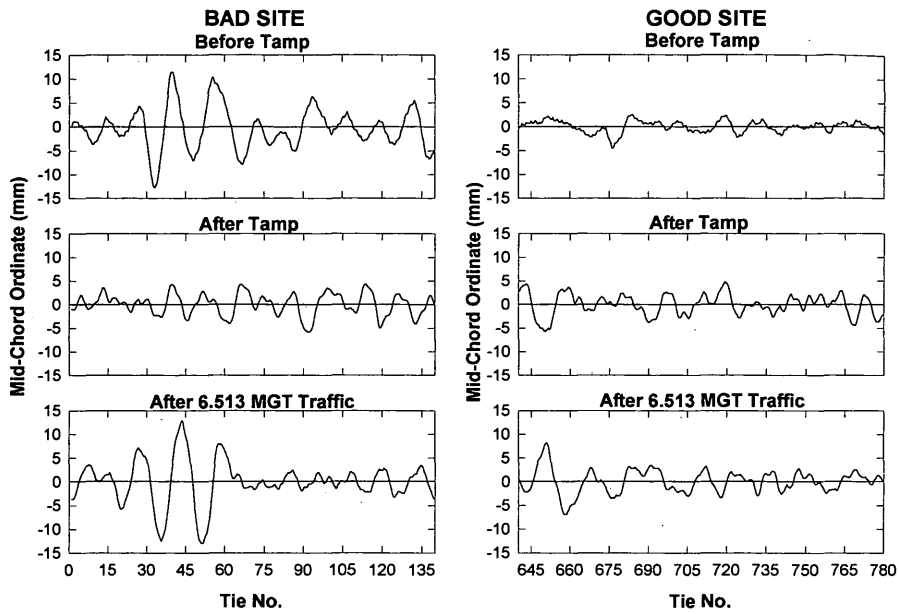

FIGURE 3 Mid-chord profiles for inner rail.

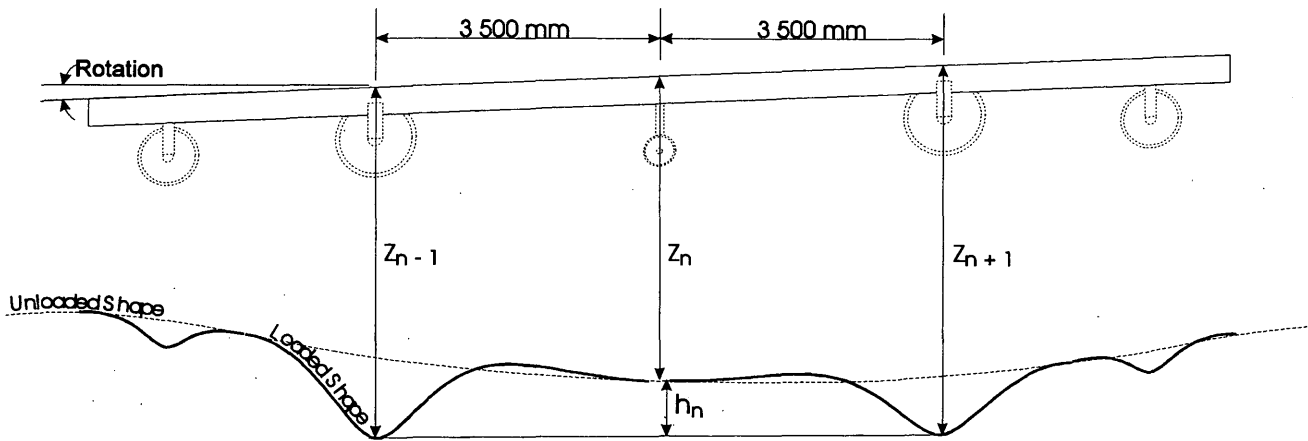

FIGURE 4 Deflection measured by geometry car.

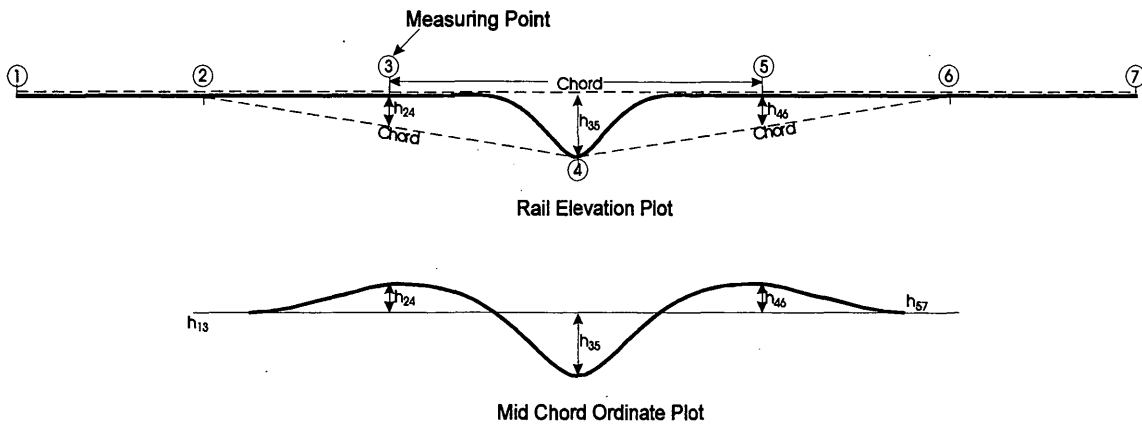

FIGURE 5 Mid-chord ordinate response to track irregularity.

$$H(\lambda) = \frac{h_n(\lambda)}{Z_n(\lambda)} = \left(1 - \cos \frac{2\pi l}{\lambda}\right) \quad (3)$$

This is demonstrated in Figure 6. This function is also known as the transfer function.

Because the mid-chord measurement is repeatable, the change in mid-chord profile measurements can be used to quantify the change in the track functional condition. The change in the loaded and unloaded longitudinal profile measurements can also be used to quantify the change in the track condition.

## TRACK ROUGHNESS

Track roughness is a measure of the vertical (or horizontal) deviation from a reference alignment over a length of track. Roughness may be expressed, for example, as the number of exceedances, standard deviations or the sum of squares of profile deviation measurements.

Undulations in the track cause vibrations in a moving train. The frequencies of the vibrations depend on the speed, weight and suspension characteristics of the train as well as the damping characteristics of the track. Longer wavelengths and lower speeds cause lower frequencies and have a less deleterious effect on the track components. A certain wavelength exists above which the induced frequencies can be ignored, and so the wavelengths longer than this can be filtered out of the functional condition measurements.

Figure 7(top) shows an example of the before-tamp unloaded longitudinal profile measurement, together with the profiles obtained by using a 7.8 m (26 ft) and 23.4 m (77 ft) filter length. The filtering was accomplished by subtracting the mean of the elevation readings over the filter length from the elevation reading at the point under consideration. This has the effect of removing wavelengths longer than the filter length.

The sum of squares calculation for roughness  $R^2$  for a surveyed profile is given by

$$R^2 = \left(\frac{\sum_{i=1}^n d_i^2}{n}\right) \quad (4)$$

where  $d_i$  is the difference between the elevation of the point being measured and filtered mean elevation measurements and  $n$  is the number of measurements in the length of track under consideration.

It should be recognized that the value of roughness for a given geometry depends on three parameters: (a) the length of track being included in the calculation, (b) the smoothing or filtering function chosen, and (c) the spacing of the measurements within the length of track, and thus the number of measurements.

The mid-chord ordinate obtained with the geometry car is already a filtered measurement, although a distorted one as shown in Figure 6. Hence for calculating roughness with Equation 4,  $d_i$  is taken as the mid-chord ordinate directly. The mean of the ordinate readings over a length of track should not be subtracted from each  $d_i$  as in calculating standard deviation, although this mean is approximately zero if a long enough length of track is used.

Figure 7(bottom) compares the mid-chord profile and the unloaded longitudinal profile, with the ordinates calculated from the unloaded survey using a 7.8 m (26 ft) chord length. The wavelengths and the peaks and valleys in these two profiles correspond, but the amplitudes vary.

## BACKCALCULATION OF LONGITUDINAL PROFILES FROM MID-CHORD ORDINATE MEASUREMENTS

If the functional condition of the track is measured only to determine whether the condition of the track is deteriorating, it is not necessary to measure the absolute longitudinal profile of the track. Instead measures such as roughness and exceedances obtained with the geometry can be used. However, if the geometry measurements are needed to identify the different track defects and how they

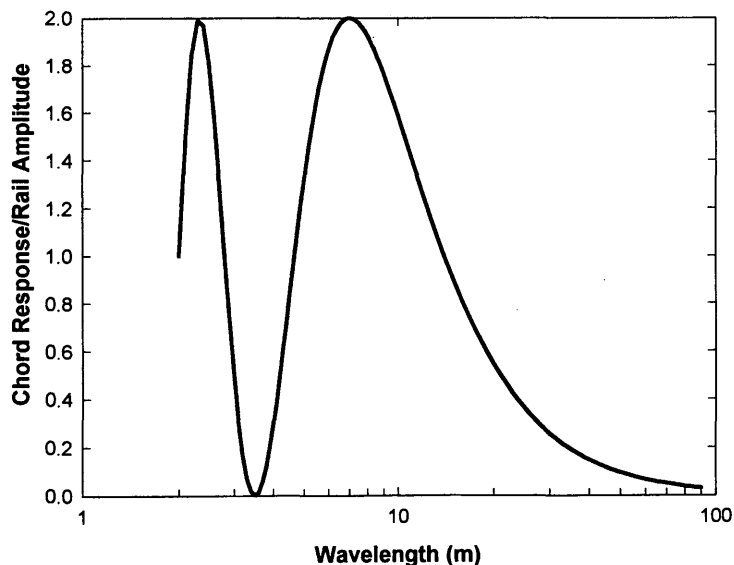

FIGURE 6 Response function for mid-chord ordinate measurements.

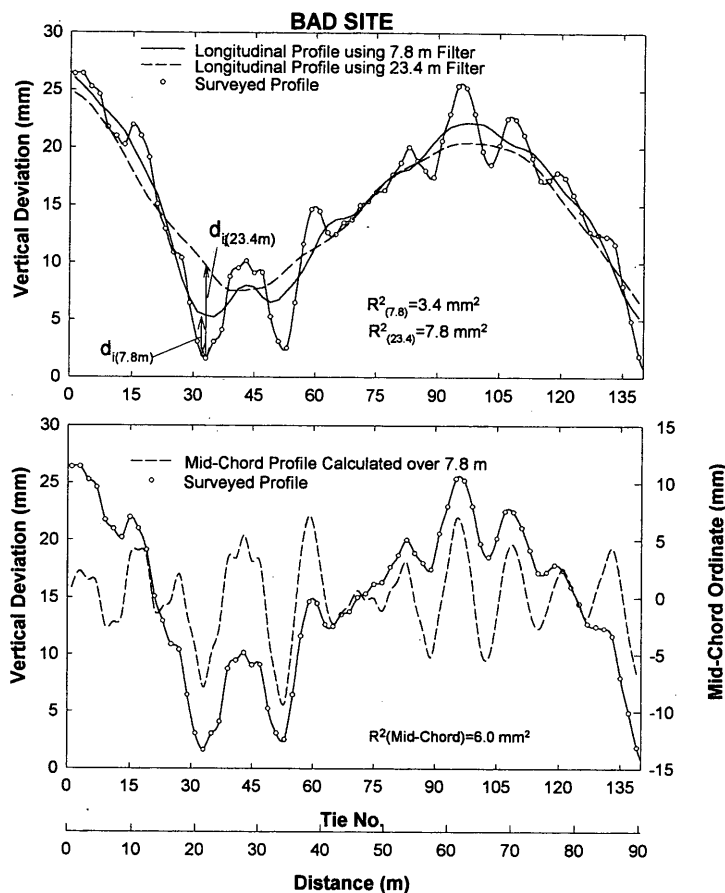

FIGURE 7 Actual longitudinal profile at bad site compared with filtered profile and mid-chord profile.

develop, the wavelengths and the associated amplitudes in the track should be determined. A typical classification of wavelengths as used by the Netherlands Railways is given in Table 2.

Two approaches can be followed to determine the longitudinal profile by converting the mid-chord ordinate measurements obtained from the geometry car. The first is geometric analysis, and the second is a Fourier transformation analysis using the transfer function that exists between  $h_n$  and  $Z_n$ .

**Geometric Approach**

To reconstruct the longitudinal profile from mid-chord measurements using the geometric approach, the relationship as indicated in Figure 8(top) will be used. If the positions of Points 1 and 2 are known, the position of Point 3 can be determined by extending the line joining the first two points and finding that Point 3 is twice the mid-chord offset from this line. The calculation of the position  $Z_3$  on the profile with the variables defined in Figure 8 is given by the following:

$$Z_3 = Z_2 + (Z_2 - Z_1) + 2h_2 \tag{5}$$

Figure 8(bottom) shows the procedure followed to determine the position of each point by successively calculating values of  $h$  at intervals of  $l$ . In its general form the absolute position of a single

TABLE 2 Wavelength Classification

Occurring in:	Wavelength (m)	Phenomenon	Monitoring Technique
Rail	0.01 to 0.03	Corrugations	Axle box and rail
	0.01 to 0.10	Poor weld & wheels	acceleration
	2 to 3	Rolling defects	acceleration
Ballast	3 to 25	Versine top gauge twist	Chord or inertial measurements
	25 to 70	Alignment & profile	Date levels
	70 to ∞	Alignment & profile	Laser levels

point on the line relative to the first two points is given by the following:

$$Z_n = Z_2 + (n - 2) (Z_2 - Z_1) - 2 \sum_{r=2}^{n-1} (n - r) h_r \tag{6}$$

Equation 6 depends on the position of the first two points as well as the difference between their positions. A small error in the measurement of these two positions will result in a cumulative error in the backcalculated  $Z$  value. This consideration, as well as the fact that the longitudinal profile induced track forces are less sensitive to longer wavelengths, suggests that the longitudinal profile should be calculated by filtering out the longer wavelengths.

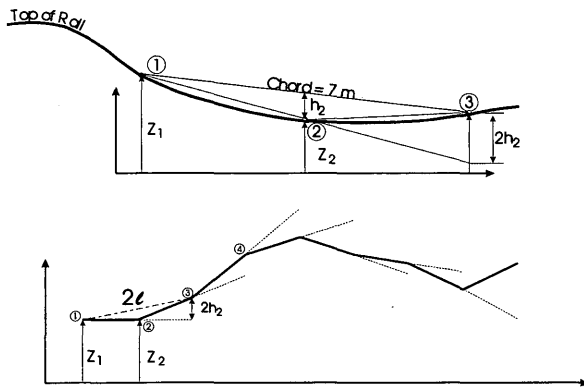

FIGURE 8 Geometrical approach for backcalculation of longitudinal profile.

Thus moving average over  $(2s + 1)$  points about  $Z_n$  is used to calculate the longitudinal profile as follows:

$$Z_s(n) = Z_n - \frac{1}{(2s + 1)} \sum_{m=-s}^{+s} Z_{n+m} \quad (7)$$

where  $(2s + 1)$  is the number of readings in the averaging distance or filter length and  $Z_s(n)$  is the true longitudinal profile at the  $n$ th point which is a function of  $s$ .

Thus there are  $S$  readings included on each side of the  $n$ th point.

#### Fourier Approach

To reconstruct the longitudinal profile from mid-chord measurements using the Fourier approach,  $h_n$  is transformed to a Fourier equation after which the transfer function given in Equation 4 is used to obtain the  $Z_n$  values.

The two approaches were found by the writers to give comparable values for wave amplitudes, and hence show promise for overcoming the amplitude distortions caused by the mid-chord measuring system. However, approaches (geometric and Fourier) will only give actual wave forms with the long wavelengths filtered out. From Figures 1 and 2 it can be seen that the predominant lengths of the long waves are between 3 m and 10 m (10 ft and 33 ft).

#### FUNCTIONAL PERFORMANCE OF TEST SITES

The loaded and unloaded roughness using a 13-m (43-ft) filter length for the surveyed measurements and the mid-chord profile roughness were determined for each test site. Figure 9 shows these results for the unloaded and the mid-chord profile measurements. The trends are the same but the values differ due to the difference in measuring principle as explained above. To describe the roughness growth rate of each site mathematically, a power function was fitted to the roughness values using statistical curve-fitting methods. The power function starts at the initial roughness after tamping at 0 MGT, and rises at a rate described by  $a$  and  $b$  as follows:

$$y = r + ax^b \quad (8)$$

where

- $y$  = roughness ( $\text{mm}^2$ ),
- $x$  = traffic (MGT),
- $a$  = scale factor,
- $b$  = shape factor, and
- $r$  = initial roughness ( $\text{mm}^2$ ).

This function fit the bad site data in Figure 9 very well, but not the good site.

Not enough loaded roughness measurements are available to describe a trend, but the roughness values for the bad and good sites before tamping are  $19.5 \text{ mm}^2$  ( $0.03 \text{ in.}^2$ ) and  $3.0 \text{ mm}^2$  ( $0.005 \text{ in.}^2$ ) respectively, and after 0.6 MGT of traffic they are  $10.1 \text{ mm}^2$  ( $0.02 \text{ in.}^2$ ) and  $7.1 \text{ mm}^2$  ( $0.01 \text{ in.}^2$ ).

After an initial set of profile measurements, smoothing tamping was performed in both sections to provide an opportunity for monitoring the track functional deterioration starting with a newly tamped track. As depicted in Figure 9, for the bad site the roughness was greatly reduced by tamping, but the roughness quickly returned to an unacceptable level. In contrast, for the good site the tamping actually made the roughness worse. With further traffic the roughness increased and then quickly stabilized, even showing a tendency to decrease.

Smoothing tamping of the bad section did not solve the cause of the bad site geometry problems and it also did not gain any meaningful length of tamping cycle. Tamping disturbed the stable conditions in the good site, indicating that tamping should not be done on a section of track if it is in a stable condition with an acceptable geometry.

The primary application of the geometry car results is to monitor the deterioration of the functional condition of a track, either on an overall system basis or on a short length for a maintenance project. In both instances the geometry results should be used to identify sections with the same inherent geometry characteristics. This can be done by using either the mid-chord profiles or the backcalculated longitudinal profiles to study the rate at which roughness develops. Care should be taken to identify singular features (such as bridges, signals, and level crossings) during such an investigation.

Grouping sections with the same inherent geometry characteristics is beneficial in maintenance planning as it may represent areas with similar maintenance needs. The sections identified should then be investigated to determine the correct maintenance input. A high roughness does not mean that the track should just be tamped. Some other maintenance action may also be required to make the improved geometry last.

As an example, one 700-m (1.1-mi) length of track, which included the two test sections, was investigated to identify sections with similar characteristics using the mid-chord profile measurements. Figure 10 shows the mid-chord ordinates with dotted lines. The track features along the length of the track are indicated with the solid vertical lines. A running roughness profile is calculated to identify sections of track which show similar roughness levels. Each roughness point on the profile represents 200 measurements spread over a 50-m (164-ft) length of track. The point is plotted at a distance coinciding with the center of the 50-m (164-ft) length. In practice, the length of track used in a roughness calculation should probably be the minimum length of track considered for maintenance work. The roughness plot in Figure 10 clearly identifies different sections, but it gives no indication of what the cause of the problems are in the bad sections.

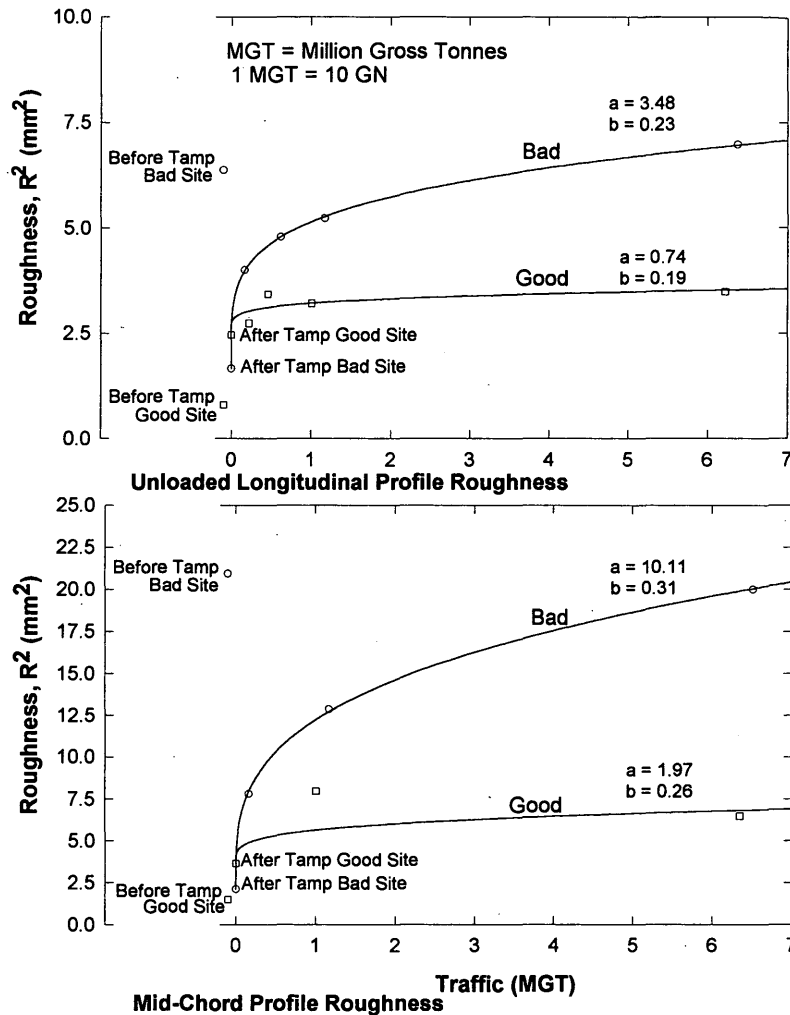

FIGURE 9 Roughness change with maintenance and traffic.

Comparison of successive recording car measurements, combined with the investigation of problem sections, can provide a means to estimate future tamping schedules for each section. Thus more effective scheduling of tamping operations can be achieved. This can be done by determining the increase in roughness based on the mid-chord profile or using a backcalculated longitudinal profile. The advantage of the latter is that it represents the actual amplitudes and wavelengths, which can be used to investigate the increase in wavelength amplitudes that should relate to the cause of geometry deterioration.

## CONCLUSIONS

The track recording car is typically used to detect geometry specification exceedances. However, it has much more potential. This paper investigated the uses of vertical profile geometry.

The mid-chord ordinate gives a measure of the geometry with long wavelengths removed, although the amplitudes of the shorter waves are altered from their actual values. These mid-chord measurements can be used to calculate the actual vertical profile

geometry with long wavelengths removed. The lengths and amplitudes of the individual waves then can be determined from these profiles to provide a basis for diagnosing the source of the geometry problems.

Track roughness can also be calculated from the mid-chord ordinate measurements or from the backcalculated profiles using the definition proposed in the paper. Observing changes in roughness with traffic will provide a basis for projecting future maintenance requirements. A moving roughness profile of the track can easily be generated from the mid-chord ordinate measurements or, with more effort, from the backcalculated profile. The roughness profile has great potential for distinguishing sections of track with the same inherent geometry characteristics. The individual sections can then be examined to determine the correct maintenance actions.

Loaded and unloaded longitudinal profiles obtained by surveying means give a more accurate representation of the track geometry than is available from the recording car. Loaded profiles are preferred because they represent the track as seen by the trains. However, surveying techniques or their equivalent are presently limited to local section investigations because they cannot collect the data over long distances as quickly and efficiently as the recording car.



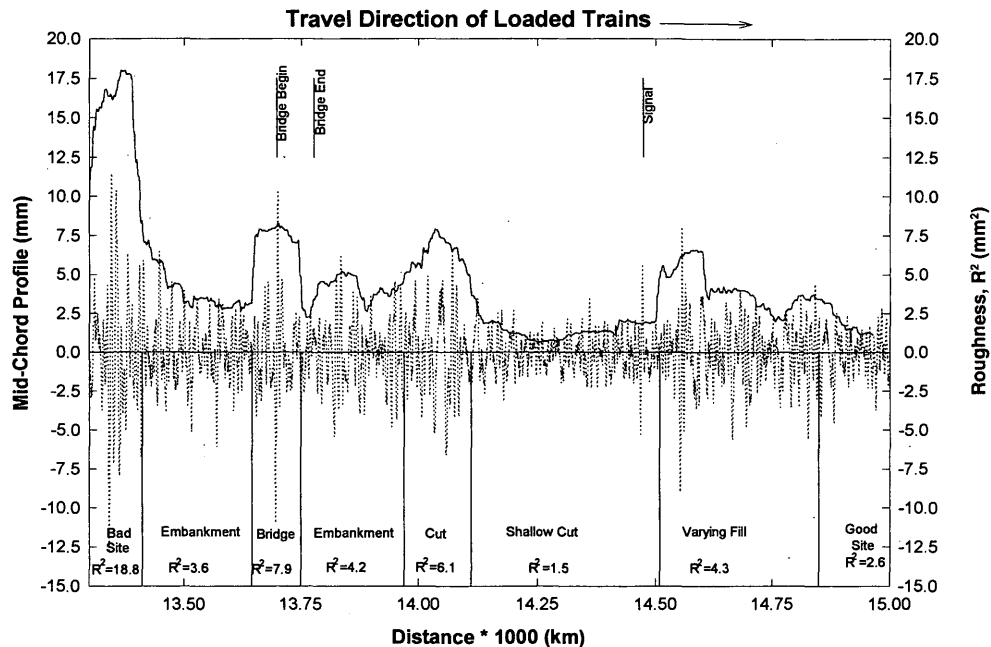

FIGURE 10 Maintenance section identification using moving roughness.

The moving roughness analysis approach was extended to many kilometers of coal line track. The preliminary conclusions were as follows:

- For 20 percent of the section the improved surface geometry following tamping would not last very long; to reduce maintenance cost, some other remedial action would be needed in addition to tamping.
- For 50 percent of the section tamping was not needed because the surface was satisfactory.
- Tamping would provide a long enough lasting surface to be effective by itself for only 30 percent of the section.

Without this analysis the entire section may have been scheduled for tamping on a regular basis as dictated by localized problem areas. Thus, a significant potential for better use of maintenance resources is possible.

#### ACKNOWLEDGMENT

The authors wish to express their appreciation to SPOORNET, whose support made this paper possible, and to all the personnel from the Track Testing Center and the University of Pretoria Civil Engineering Department who took part in the investigation. The analysis techniques were developed as part of research at the University of Massachusetts, supported by the Association of American Railroads.

#### REFERENCE

1. Kuys, W. C. Track Structure Failure Under 26-Ton Axle Loads on South African Transport Services Coal Line. *Proc., 4th International Heavy Haul Railway Conference*, Brisbane, Australia, Sept. 1989, pp. 391-395.

*Publication of the paper sponsored by Committee on Railway Maintenance.*