

Lawrence Berkeley National Laboratory

Lawrence Berkeley National Laboratory

Title

Use of whole building simulation in on-line performance assessment:
Modeling and implementation issues

Permalink

<https://escholarship.org/uc/item/4q7923xn>

Authors

Haves, Philip
Salsbury, Tim
Claridge, David
[et al.](#)

Publication Date

2001-06-15

HPCBS

High Performance Commercial Building Systems

Use of Whole Building Simulation in On-Line Performance Assessment: Modeling and Implementation Issues

Philip Haves

Ernest Orlando Lawrence Berkeley National Laboratory

Tim Salsbury

Johnson Controls Inc.

David Claridge

Texas A&M University

Mingsheng Liu

University of Nebraska

June 15, 2001



DISCLAIMER

This document was prepared as an account of work sponsored by the United States Government. While this document is believed to contain correct information, neither the United States Government nor any agency thereof, nor The Regents of the University of California, nor any of their employees, makes any warranty, express or implied, or assumes any legal responsibility for the accuracy, completeness, or usefulness of any information, apparatus, product, or process disclosed, or represents that its use would not infringe privately owned rights. Reference herein to any specific commercial product, process, or service by its trade name, trademark, manufacturer, or otherwise, does not necessarily constitute or imply its endorsement, recommendation, or favoring by the United States Government or any agency thereof, or The Regents of the University of California. The views and opinions of authors expressed herein do not necessarily state or reflect those of the United States Government or any agency thereof, or The Regents of the University of California.

This report was prepared as a result of work sponsored by the California Energy Commission (Commission). It does not necessarily represent the views of the Commission, its employees, contractors, and subcontractors make no warranty, express or implied, and assume no legal liability for the information in this report; nor does any party represent that the use of this information will not infringe upon privately owned rights. This report has not been approved or disapproved by the Commission nor has the Commission passed upon the accuracy or adequacy of the information in this report.

Ernest Orlando Lawrence Berkeley National Laboratory
is an equal opportunity employer.

Presented at the Seventh International IBPSA Conference Building Simulation 2001, August 13-15, 2001 in Rio de Janeiro and published in the proceedings.

USE OF WHOLE BUILDING SIMULATION IN ON-LINE PERFORMANCE ASSESSMENT: MODELING AND IMPLEMENTATION ISSUES

Philip Haves
Building Technologies Department
Environmental Energy Technologies Division
Ernest Orlando Lawrence Berkeley National Laboratory
University of California
1 Cyclotron Road
Berkeley, California 94720

Tim Salsbury
Johnson Controls Inc.
Milwaukee, Wisconsin

David Claridge
Texas A&M University
College Station, Texas

Mingsheng Liu
University of Nebraska
Omaha, Nebraska

June 15, 2001

This report describes results from our task with the High Performance Commercial Buildings Systems Program. For information about other reports and other tasks, please visit buildings.lbl.gov/CEC/

This work was supported by the California Energy Commission, Public Interest Energy Research Program, under Contract No. 400-99-012 and by the Assistant Secretary for Energy Efficiency and Renewable Energy, Office of Building Technology, State and Community Programs, Office of Building Research and Standards of the U.S. Department of Energy under Contract No. DE-AC03-76SF00098.

USE OF WHOLE BUILDING SIMULATION IN ON-LINE PERFORMANCE ASSESSMENT: MODELING AND IMPLEMENTATION ISSUES

Philip Haves, Lawrence Berkeley National Laboratory
Tim Salsbury, Johnson Controls Inc., Milwaukee, Wisconsin
David Claridge, Texas A&M University, College Station, Texas
Mingsheng Liu, University of Nebraska, Omaha, Nebraska

ABSTRACT

The application of model-based performance assessment at the whole building level is explored. The information requirements for a simulation to predict the actual performance of a particular real building, as opposed to estimating the impact of design options, are addressed with particular attention to common sources of input error and important deficiencies in most simulation models. The role of calibrated simulations is discussed. The communication requirements for passive monitoring and active testing are identified and the possibilities for using control system communications protocols to link on-line simulation and energy management and control systems are discussed. The potential of simulation programs to act as "plug-and-play" components on building control networks is discussed.

INTRODUCTION

There is an increasing realization that many buildings do not perform as intended by their designers. Reasons include faulty construction, malfunctioning equipment, incorrectly configured control systems and inappropriate operating procedures. The first step in detecting and diagnosing such problems is the evaluation of building performance. A quantitative evaluation of performance requires a baseline or reference, against which to compare the actual performance. Possible sources of such a baseline include:

1. The previous performance of comparable buildings
2. The current performance of comparable buildings
3. The previous performance of the building in question
4. The intended performance of the building in question

In the first case, a database of the actual performance of a statistically selected sample of buildings is used to compare the performance of the building in question to that of similar buildings. The comparison is usually made in terms of whole building electricity and fuel consumption. This 'benchmarking' process can provide an approximate assessment of relative performance from very modest input data, typically building type, floor area and geographical location. Benchmarking is a useful screening tool, allowing

attention to be focused on those buildings that appear to be performing poorly.

In the second case, owners of campuses or chains with suitable monitoring capabilities can make comparisons between buildings on the time-scale of an hour to a week to detect the onset of malfunctions that have a significant effect at the whole building level. This quasi-real-time form of benchmarking provides a relatively simple method of detecting significant degradations in performance before the cumulative effects of that degradation become severe.

In both the first and second cases, simple regression models are typically used to correct for differences between the conditions under which the actual performance is observed and the conditions for the baseline. However, simulation models are starting to be used as interpolation tools for more sophisticated benchmarking where more information about the buildings and their energy systems is available.

In the third case, the previous performance can be represented using a 'calibrated simulation', in which the parameters of the model are adjusted to minimize the difference between the predicted and measured performance over a selected period. The model can either be a detailed first principles model, such as EnergyPlus (Crawley et al. 2000), DOE-2 (LBNL 1982) or ESP (ESRU 2000), a simplified first principles model, such as AIRMODEL (Liu and Claridge 1998), or an empirical model, such as an artificial neural network (Kreider and Haberl 1994). In addition to providing a baseline for future performance, first principles models can also be used to identify more efficient operating strategies. Detailed first principles models tend to be over-parameterized for the measurements that are available in practice, suggesting that simplified first principles models may be more appropriate. This approach is discussed in a later section. In the fourth case, use of a whole building simulation program is the natural method of representing intended performance. Comparison of actual and intended performance can be made either during commissioning or during routine operation.

In the second, third and fourth cases, comparisons of energy use, peak demand and comfort conditions can be made on time-scales ranging from hours to weeks.

In general, a longer time-scale results in greater accuracy of the prediction but less information that may be useful in diagnosing the nature of any faults or problems.

An interesting example of the third case, but on a longer time-scale, is a particular office building in Oakland, California. The design-build contract for the construction was let on the basis of a DOE-2 model of the planned building. The contractor stood to gain or lose up to \$250,000, depending on the performance of the building during the second year of occupancy as compared to the expected performance defined by the DOE-2 model (Stein et al. 2000).

There are, however, difficulties in using models intended for use in design to predict the performance of real buildings, including:

- Lack of the necessary input data
- Limitations of the model, which usually take the form of assumptions of idealized behavior of the envelope, mechanical equipment or controls

These difficulties are now discussed. Implementation issues are addressed later in the paper.

INPUT DATA

Heating and cooling energy consumption depends on building characteristics, occupancy, operational schedules, type of HVAC system, weather and other parameters. When the aim is to compare actual performance with the performance expected by the designer, the role of simulation is to correct for factors such as occupancy, internal gains and weather that are beyond the control of the designer. A major area of uncertainty is the calculation of heating and cooling loads; specific uncertainties include:

Solar Gain

- Insolation measurement: Individual buildings generally do not have an on-site solarimeter. There may be a weather station nearby; even then there can be problems with getting the data in real time and with data quality.
- Effect of surrounding buildings: In addition to shading, reflection may also be important, especially in downtown areas. A detailed approach to modeling this phenomenon is described in Reilly et al. (1994).
- Blinds: Manual operation is difficult to model.

The importance of estimating solar gain accurately depends on the type of building. A local measurement of insolation is most important for a shallow-plan building with large areas of relatively clear glazing.

Internal Gains

- Plug loads: Electrical submetering is only available in a few existing buildings; it can be installed more easily if planned for during design.
- Lighting: Again, measurements are made in a few existing buildings; they can be made more easily if planned for during design. Complications are introduced by air-handling luminaires and by outside lighting on the same circuits as inside lighting.
- Occupants: It is only possible to measure occupant numbers in certain situations, e.g. where there are time clocks, security cards etc. Metabolic rate and location in a particular thermal zone must be assumed

In the absence of measurements, plug loads can be estimated from nameplate ratings. In one case study (Wilkins 1998), the measured maximum consumption of each item of equipment was ~50% of the nameplate rating and the diversity factor was ~2. Alternatively, the internal gain may be estimated by using measured whole building electricity consumption. This approach may also significantly over-estimate the heat gain since a large fraction of whole building electricity use, such as that used by pumps, exhaust fans, elevator motors, and air compressors, may be converted to heat in non-conditioned spaces, such as mechanical rooms, basements, and penthouses. Even the heat generated in the conditioned space may not become cooling load if air-handling luminaires are installed since some of the lighting energy is picked up by the return air and some of that energy is carried out directly to the outside by the exhaust air.

Given these sources of uncertainty in the estimation of heating and cooling loads, there are three possible approaches:

1. Installation of the necessary instrumentation in the building, e.g., a solarimeter, electricity sub-meters, to provide measurements of the inputs required by conventional, first principles, simulations in order to calculate heating and cooling loads. A sensitivity study for the building in question is required to estimate the accuracy required for each type of measurement.
2. The 'calibrated simulation' approach, in which an empirical model of heating and cooling loads is calibrated by adjusting the values of its parameters so as to minimize the differences between the predicted and measured performance of the building over a period when the performance is deemed to be acceptable.
3. Direct measurement of the heating and cooling loads. For air systems, the load on the HVAC system can be determined by measuring the supply air-flow rate and the supply air and return air temperature and humidity.

The second and third approaches allow a first principles HVAC system model configured from design data to be used even when measurements of the boundary conditions required by a first principles model of the heating and cooling loads are not available.

CALIBRATED SIMULATION

The calibration process compares the results of the simulation with measured data and "tunes" the simulation until its results closely match the measured data. Systematic calibration of building models has been reported by a number of researchers dating as far back as 20 years (Diamond and Hunn 1981, Holtz 1990, Kaplan et al. 1992, Pratt 1990). The early calibration efforts focused on matching the monthly totals for the simulated heating and cooling consumption to the measured monthly electricity and gas utility bills. However, there are typically more simulation inputs that can be varied than measured data points. This severely limits calibration accuracy. More recent research on the calibration process has focused on comparing hourly measured data with simulation because the results represent the building dynamic energy characteristics in a more accurate and reliable way (Bou-Saada and Haberl 1995, Bronson et al. 1992, Haberl et al. 1995, Haberl and Bou-Saada 1998). Graphical and statistical comparison techniques are used to examine the fit between the thousands of data points being compared. Simulations based on the ASHRAE Simplified Energy Analysis Procedure (Knebel 1983) have been calibrated using daily data (Knebel 1983, Liu et al. 1998) and successfully used as part of a diagnostic process.

MODELING ISSUES

Zoning

Model simplification, which limits input detail to items that have a detectable impact on the measured energy use, is highly desirable to reduce the effort, and the ambiguity, associated with model calibration. Forms of simplification include the use of lumped, rather than explicit, representations of the building envelope and reduction in the number of zones that are modeled. Knebel (1983), Katipamula and Claridge (1993) and others have found that buildings can often be adequately treated as two zones: core and perimeter. A case study based on this approach, presented by Liu and Claridge (1995), showed very accurate results. An air side simulation program (Liu and Claridge 1995) has been developed using the two-zone model. The simulation program has been used to calibrate the system model, identify system operational problems and optimize system operation by two of the authors (DC and ML) since 1993. This experience indicates that the two-zone model works well provided the interior and exterior zones are properly determined. In

the case of open-plan spaces, a good rule of thumb is that the perimeter zone extends 6 m (20 ft) in from the exterior surface.

Imperfect Operation of Mechanical Equipment

Even the more detailed whole building simulation models are generally based on idealized models of building and system performance. These idealizations are another important factor in the discrepancies that are often seen between simulation results and measured performance. A simulation model must be able to treat the departures from ideal behavior that occur in real systems if it is expected to portray system performance accurately. The question as to whether particular operation is considered acceptable or faulty varies from case to case. In practice, a fault that is not considered important enough to fix is considered acceptable and models of real building operation need to be able to treat this type of operation. Some examples follow; further details are given by Liu et al. (1998):

- **VAV Terminal Box:** A VAV box modulates the air-flow rate to maintain room temperature and/or minimize the reheat. Idealized models assume that the box can reduce the flow rate to the design minimum value but a combination of poor damper quality and high static pressure at the box may limit the turndown that is achieved in practice.
- **Dual Duct Terminal Boxes:** Under full cooling conditions, the pressure on the hot air damper is high because there is little pressure drop between the fan and the terminal box because the hot air flow rate is small. This high pressure often results in significant leakage through the damper, resulting in simultaneous heating and cooling. A similar problem arises with leakage through the cold air damper under full heating conditions.
- **Coils and Control Valves:** Most simulation programs assume that coils and control valves can maintain the temperature reset schedules, which involves maintaining control of off-coil air temperature over the complete range of load. This assumption breaks down when the coil load is 20% or lower. Most control valves have a turndown range of 20:1 to 40:1; if the valve has an authority of 0.5, the minimum predictable flow varies from 5% to 10% of range which, because of the non-linear relationship between water flow rate and load, corresponds to ~10-20% of full load. In addition, there is almost always significant leakage in real systems. Under high cooling loads, hot water leakage is increased due to increased differential pressure across the hot water control valve. During high heating loads, the chilled water leakage is high due to increased chilled water differential pressure across the chilled water valve. Pre-heat coils often heat up the supply air by 3°F or more during summer months if hot water or

steam is supplied to the coil. The re-heat coil may also warm the supply air 3°F or more during full cooling mode due to leakage.

Thus, models that seek to represent the behavior of real systems should be able to account for imperfect control of supply air temperature and flow rate and for simultaneous heating and cooling. The magnitudes of these effects are case-specific and the model parameters that define these magnitudes need to be identified from the measured performance.

Controls

Another limitation of current whole building simulation models is their inability to model real control strategies, even generically. Controls are modeled in an idealized way:

- Local loop behavior is not modeled:
 - Whereas some HVAC processes are quite fast, there are some that have dominant time constants of 10 minutes or more: room temperature control, chilled water and condenser loop latencies (transport delay in piping systems, capacity of cooling tower sumps);
 - Proportional control is often used for most of the HVAC components in an old system while the simulation assumes ideal control. Actual temperatures, including room temperatures, are then significantly offset from their set-points under most operating conditions.
- The effect of equipment cycling on control and efficiency is not directly modeled.
- Reset strategies are often implemented with low gain integral control, which leads to relatively a sluggish response, rather than the instantaneous response assumed in whole building simulation programs.

ON-LINE IMPLEMENTATION

The first part of the paper has addressed some of the information and modeling issues that arise when using whole building simulation programs as reference models of correct operation for the assessment of building performance. The remainder of the paper addresses some of the implementation issues that arise

in on-line implementation to support real-time performance assessment.

Performance assessment can either be:

- Passive—data from routine operation are analyzed for evidence of faults
- Active—test signals are generated by the performance assessment software and transmitted to the building control system in order to exercise the building and hence acquire data that cover a wide range of the operating space

Passive monitoring has the advantage of being non-intrusive and can be performed on-line or off-line. However, its diagnosis capabilities are limited by the fact that the data from different regions of the operating space usually needed to distinguish between different faults may have been collected over a significant period of time, during which the fault condition may have changed significantly, confusing the diagnosis. Passive monitoring only requires one-way communication between the performance assessment software and the building control system, as shown in **Figure 1a**. The data transmitted by the building control system include the meteorological measurements and other boundary conditions for the simulation, together with measurements of electric power, temperature, flow rate etc for comparison with the predictions of the simulation.

Active testing can significantly alter the comfort conditions in a building and hence is usually performed when the building is unoccupied, either prior to hand-over or during evenings or weekends. It must be performed on-line and requires two-way communication between the performance assessment software and the building control system, as shown in **Figure 1b**. The data transmitted by the performance assessment software include the set-point changes required to drive the building and its systems to different parts of the operating space.

Performance assessment for building systems is generally more concerned with the steady state performance, at least for equipment, and so there is usually no real need for synchronous communication, it being sufficient for the performance assessment

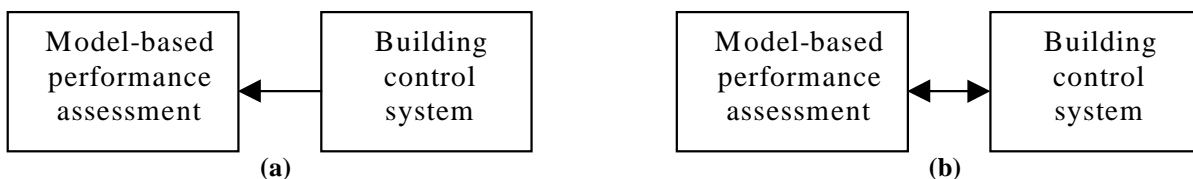

Figure 1. Data transfer requirements between (a) passive monitoring and (b) active testing.

system and the building control system to be independently synchronized to real time. A different but related application where synchronous communication may be required is where two simulation environments are coupled at run-time and the aim is to run the coupled simulation as fast as possible. Having defined the basic communication requirements, the paper now addresses software architecture and communication protocol issues.

COMMUNICATION BETWEEN SIMULATIONS AND CONTROL SYSTEMS

Modern building control systems, especially those in larger buildings, have a hierarchical structure and typically use different communication protocols at different levels, as shown in **Figure 2**.

The lowest level of communication could take place with unitary local-loop controllers. Interfacing at this level would require the use of analog to digital (A/D) and digital to analog (D/A) converters so that simulated variables could be transformed into physical variables such as voltage and vice versa.

Communication protocols such as BACnet (ASHRAE 1995) and LonWorks are primarily focused on lower level control networks comprised of controllers such as room thermostats, AHU controllers, VAV controllers, etc. OPC - Object linking and embedding for Process Control (OPC 2001) is an application-level interfacing standard that would apply at the LAN networking level. XML and other Internet protocols apply to the campus-wide or global level. Although, the division between the different levels is often blurred, it is apparent that there are now various standards and protocols to cover all levels in a building control system hierarchy.

Having a distributed and object-based simulation program greatly simplifies interconnection between the components within a simulation and with a real building control system. **Figure 3** illustrates how different parts of what could be one simulation program or multiple separate simulation programs connect to a real system. It should be noted that each level in the hierarchy that was depicted in **Figure 2** provides access to the levels below. For example, a whole building simulation connected through the Internet to a real control system could access information at the unitary controller level and could even simulate equipment at this level. However, the full realism of simulating a low-level entity by means of a simulation at a higher level would be restricted to real controllers at the same higher level as the simulation. Moreover, attempting to achieve low-level emulation through simulation interaction at higher

levels may prove prohibitive due to network bandwidth and processing constraints. Hence, simulation that is based on a distributed architecture and has interfaces at multiple levels provides the greatest opportunity and flexibility in creating cybernetic building systems.

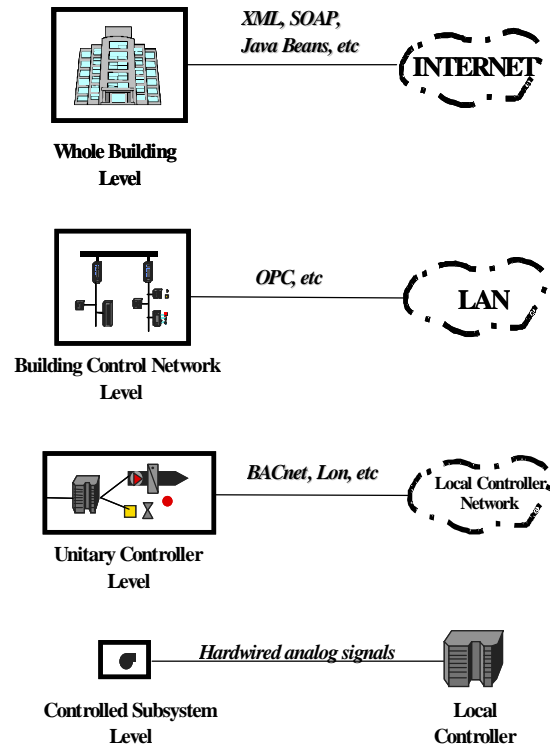

Figure 2: Multi-level communication protocols.

One of the barriers to linking analysis software, such as energy simulation, to building control systems has been the difficulty in engineering the communication interfaces required for data exchange using proprietary EMCS protocols. Application to a different EMCS often requires significant re-engineering effort and possibly the development of gateways that act as translators from one protocol to another. The availability of standardized protocols and object representations is beginning to alleviate the engineering burden of developing the communication aspects of exogenous EMCS applications such as real-time simulation. The synergy of EMCS object standards and simulation modeling information requirements and the apparent convergence of these two areas under umbrellas such as the International Alliance for Interoperability (IAI <http://www.iaiweb.lbl.gov/>) is creating opportunities for the development of “plug and play” functionality.

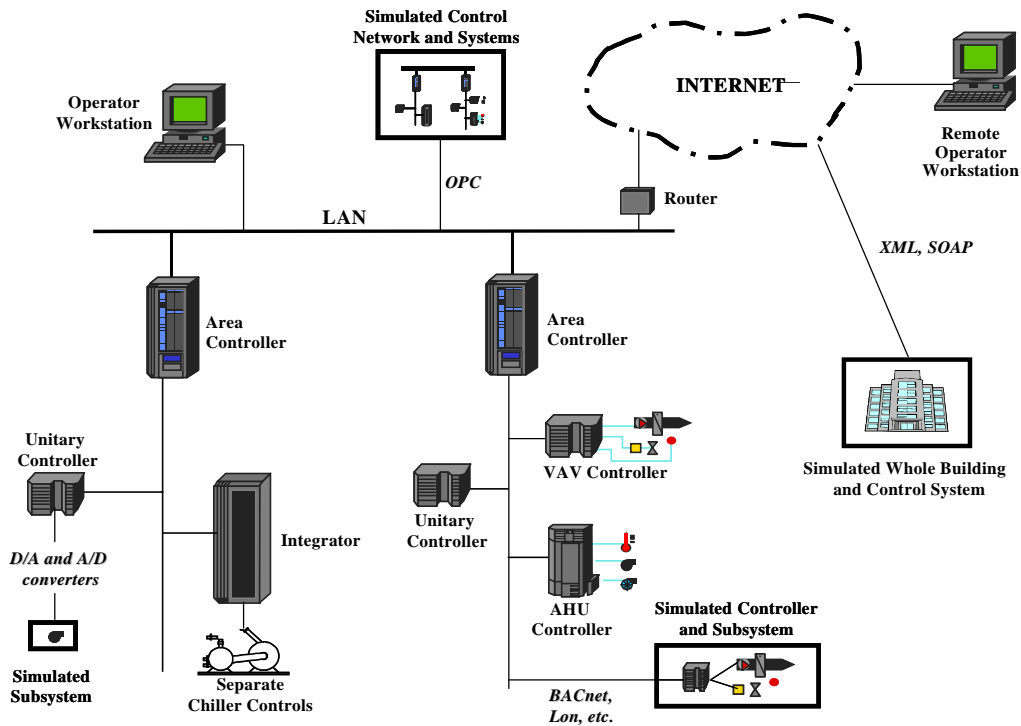

Figure 3. Multilevel simulation interaction with a typical building control system.

Distributed Objects

Figure 4 shows the benefits of a software architecture built around the concept of distributed objects (Orfali et al. 1996). ORB is an object request broker. COM/DCOM and CORBA are types of object request brokers. Interfaces are the external representations of objects. The form of an interface is dependent on the type of ORB that is used. OPC is a COM/DCOM interface specification. The types of objects used in a distributed architecture are sometimes termed “components” in order to distinguish them from “programming objects” such as C++ classes.

Although client/server terminology is still used in the case of distributed component architectures, the division between client and server is often blurred. Typically though, components are viewed as servers, capable of performing some function and being able to share that functionality through their interfaces. Clients do not usually need to expose any functionality and would normally just access the services of components’ servers. Clearly, components could have server and client capability.

.Object-Based Simulation Example

Figure 5 shows an example of a distributed simulation platform that will allow a simulation to be broken into different parts and executed in separate processes. Three separate processes handle the simulation of a building, its HVAC system and control applications. Each simulation object is

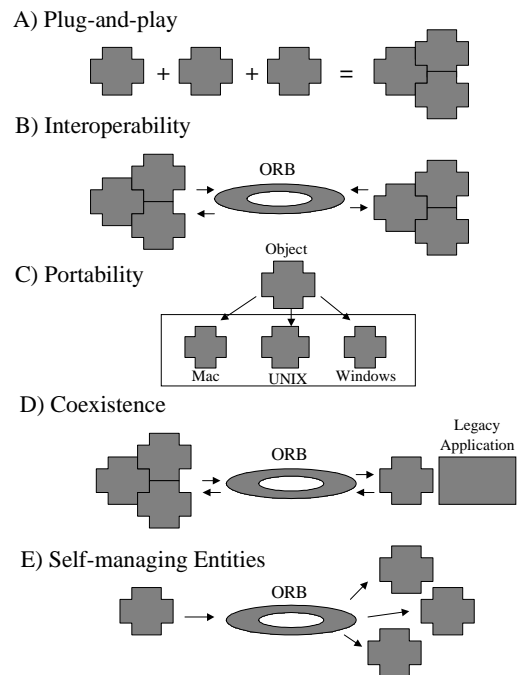

Figure 4. Benefits of distributed objects.

capable of interfacing to real hardware and this could take place at any of the hierarchical levels that were depicted in **Figure 2**.

Aside from interfacing and communication aspects, distributed simulation requires coordination between the disparate objects in terms of timing and data exchange management. For example, the data associated with one set of objects may be needed as boundary conditions in another. Coordination of the simulation objects requires either synchronization to one particular simulation object or to real time. The possibility of different simulation time-steps or controller sampling intervals for each object requires communication of information between dependent objects so that the state of a particular object can be informed or interrogated. In this scenario, the concept of software “agents” could be introduced to describe the distributed and cooperative nature of this type of simulation architecture (Oliveira et al., 1999).

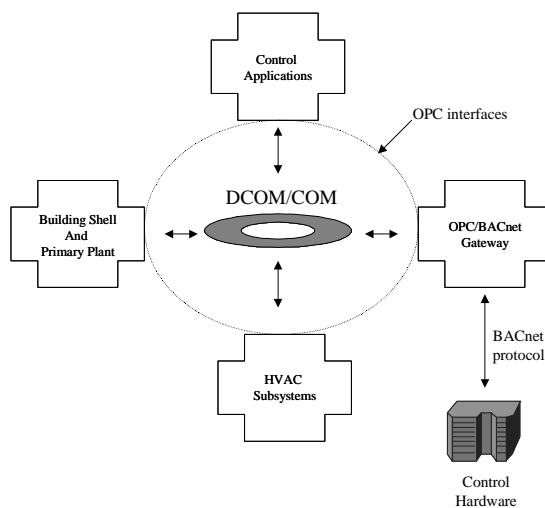

Figure 5. Object-based simulation.

CONCLUSIONS

Whole building simulation programs have the potential to act as reference models of correct operation for use in the performance assessment of real buildings. Additional sensors, over and above those usually installed in energy management and control systems, as needed to provide the necessary input data. Alternatively, calibrated simulations can be used to predict current performance from previous performance.

The standard communication protocols that are starting to be adopted in the building controls industry have the potential to be used to interface on-line simulation programs to energy management and control systems. Object-based methods provide a mechanism for defining the standard interfaces that are required for “plug’n’play” interoperability of simulation and control software components but

more work is needed to break the functionality of simulation programs into distributed components.

ACKNOWLEDGMENTS

This work was supported by the California Energy Commission, Public Interest Energy Research Program, under Contract No. 400-99-012 and by the Assistant Secretary for Energy Efficiency and Renewable Energy, Office of Building Technology, State and Community Programs, Office of Building Research and Standards of the U.S. Department of Energy under Contract No. DE-AC03-76SF00098.

REFERENCES

- ASHRAE. 1995. Standard 135-1995 - BACnet - A Data Communication Protocol for Building Automation and Control Networks. Published by ASHRAE.
- Bou-Saada, T.E. and J.S. Haberl., 1995. “An Improved Procedure for Developing Calibrated Hourly Simulation Models”. Proceedings of Building Simulation '95, International Building Performance Simulation Association, Madison, WI, August 14-16.
- Bronson, D.J., S.B. Hinchey, J.S. Haberl, and D.L. O'Neal, 1992. “A Procedure for Calibrating the DOE-2 Simulation Program to Non-Weather-Dependent Measured Loads”. ASHRAE Transactions. Vol. 98, Pt 1, pp. 636-652.
- Crawley, D. B., L. K. Lawrie, C. O. Pedersen, F. C. Winkelmann, 2000. “EnergyPlus: Energy Simulation Program”. ASHRAE Journal, Vol. 42, No. 4 (April), pp. 49-56.
- Diamond, S., and B. Hunn, 1981. “Comparison of DOE-2 Computer Program Simulations to Metered Data from Seven Commercial Buildings”. ASHRAE Transactions, Vol. 87, Pt 1.
- ESRU, 2000. The ESP-r System for Building Energy Simulation, ESRU Manual U00/1, Energy Simulation Research Unit, University of Strathclyde, UK
- Haberl, J.S., J.D. Bronson, and D.L. O'Neal, 1995. "An Evaluation of the Impact of Using Measured Weather Data Versus TMY Weather Data in a DOE-2 Simulation of an Existing Building in Central Texas." ASHRAE Transactions, Vol. 101, Pt 2.
- Haberl, J. and T. Bou-Saada, 1998. “Procedures for Calibrating Hourly Simulation Models to Measured Building Energy and Environmental Data”. ASME Journal of Solar Energy Engineering, Vol. 120, pp. 193-204, August.
- Holtz, M, 1990. "Electrical Energy Savings in Office Buildings". Swedish Council for Building Research, 1990.

- Kaplan, M., J. McFerran, J. Jansen, and R. Pratt. 1992. "Reconciliation of a DOE2.1c Model with Monitored End-use Data from a Small Office Building". *ASHRAE Transactions* Vol. 96, Pt 1.
- Katipamula, S. and Claridge, D. E., 1993. "Use of Simplified Models to Measure Retrofit Energy Savings," *ASME Journal of Solar Energy Engineering*, Volume 115, pp. 57-68.
- Knebel, D. E., 1983. *Simplified Energy Analysis Using the Modified Bin Method*, American Society of Heating, Refrigeration, and Air-conditioning Engineers, Atlanta, GA.
- Kreider, J.F. and Haberl, J.S., 1994. "Predicting Hourly Building Energy Usage: The Great Predictor Shootout -- Overview and Discussion of Results", *ASHRAE Transactions*, Vol. 100, Pt. 2.
- LBNL, 1982. *DOE-2 Reference Manual*, Lawrence Berkeley Laboratory and Los Alamos National Laboratory, Report No. LBL-8706 Rev. 2.
- Liu, M and Claridge, D.E., 1995. "Application of Calibrated HVAC System Models to Identify Component Malfunctions and to Optimize Operation and Control Schedules", *Solar Engineering 1995 - Proceedings of the 1995 ASME/JSME/JSES International Solar Energy Conference*, Vol. 1, Maui, Hawaii, pp. 209-217, March 19-24.
- Liu, M. and D.E. Claridge, 1998. "Use of Calibrated HVAC System Models to Optimize System Operation". *ASME Journal of Solar Energy Engineering*, Vol. 120, pp. 131-138.
- Liu, M., G. Wei, and D.E. Claridge, 1998. "Calibrating AHU Models Using Whole Building Cooling and Heating Energy Consumption Data", *Proceedings of the ACEEE 1998 Summer Study on Energy Efficiency in Buildings*, Volume 3, American Council for an Energy Efficient Economy, Washington, D.C., pp. 229-241.
- Oliveira, E., K. Fischer, O. Stepankova, 1998. "Multi-Agent Systems: Which Research for Which Applications". *Robotics and Autonomous Systems*. Volume 27. Page 91-106.
- OPC 2001, <http://www.opcfoundation.org/>
- Orfali, R., D. Harkey, J. Edwards. 1996. *The Essential Distributed Objects Survival Guide*. John Wiley and Sons, Inc.
- Pratt, R.G., 1990. "Errors in Audit Predictions of Commercial Lighting and Equipment Loads and Their Impacts on Heating and Cooling Estimates", *ASHRAE Transactions*, Vol. 96, Pt 2.
- Reilly, S M., Dunne, C P., Ward G J. and Winkelmann, F.C., 1994. "Modelling the solar heat gain reflected from neighbouring structures", *ASHRAE Trans*, Vol. 100, Pt 2.
- Stein, R.S., A. Raychoudhury, and C. Eley. 2000. "The Jury Is (Halfway) In: New Building Performance Contracting Results", Proceedings of the ACEEE 2000 Summer Study on Energy Efficiency in Buildings, American Council for an Energy Efficient Economy, Washington, D.C.
- Wilkins, C. K., 1998. "Electronic Equipment Heat Gains in Buildings", *ASHRAE Transactions*, Vol. 104, Pt 1.